



# THE DATASHEET OF LM3561TME/NOPB



# Synchronous Boost Converter With 600-mA High-Side LED Driver and I<sup>2</sup>C-Compatible Interface

Check for Samples: [LM3561](#)

## FEATURES

- High-Side Current Source Allows Grounded LED Cathode
- Up to 90% Efficient
- Ultra-Small Solution Size: <math><16\text{mm}^2</math>
- Three Operating Modes: Torch, Flash, and LED Indicator
- Accurate and Programmable LED Current from 18mA to 600mA
- Hardware Flash and Torch Enable
- LED Thermal Sensing and Current Scaleback
- Software Selectable Input Voltage Monitor
- Programmable Flash Timeout
- Dual Synchronization Inputs for RF Power Amplifier Pulse Events
- Open and Short LED Detection
- Active High Hardware Enable for Protection Against System Faults
- 400kHz I<sup>2</sup>C-compatible Interface

- 12-Bump (1.215mm × 1.615mm × 0.6mm) DSBGA Package

## APPLICATIONS

- Camera Phone LED Flash Controller
- LED Current Source Biasing

## DESCRIPTION

The LM3561 is a 2-MHz fixed-frequency current-mode synchronous boost converter. The device is designed to operate as a single 600-mA constant current driver for high-current white LEDs. The high-side current source allows for grounded cathode LED operation while the 250-mV regulated headroom voltage ensures that the LED current is well regulated and efficiency remains high.

## Typical Application Circuits

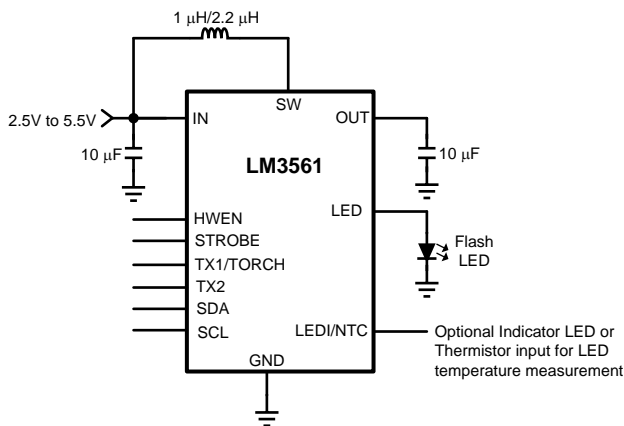
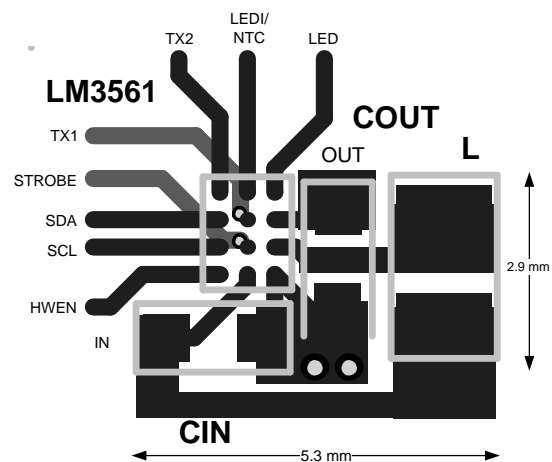
**Figure 1.**

**Figure 2. Example Layout**

Please be aware that an important notice concerning availability, standard warranty, and use in critical applications of Texas Instruments semiconductor products and disclaimers thereto appears at the end of this data sheet.

All trademarks are the property of their respective owners.

## DESCRIPTION (CONTINUED)

The main features of the LM3561 include: an I<sup>2</sup>C-compatible interface for controlling the LED current, a hardware Flash enable input for direct triggering of the Flash pulse, dual TX inputs (TX1 and TX2) which force the Flash pulse into a low-current Torch mode during high battery current instances, an active high hardware enable (HWEN) allowing for fast hardware shutdown during system software failures, a dual mode pin which serves as either an indicator LED driver at up to 18mA or as a dedicated comparator input with an internal 1V reference, designed to monitor the voltage across a negative temperature coefficient thermistor (NTC), and a programmable input voltage monitor which monitors IN and can reduce the flash current or shutdown the device during low battery conditions.

Seven fault flags are available for read back over the I<sup>2</sup>C-compatible bus. These include: a flash timeout flag indicating the flash pulse has reached the end of the programmable timeout duration, a thermal shutdown flag indicating the LM3561's die temperature has exceeded 150°C, an LED fault flag indicating the output voltage has tripped the over-voltage threshold, or the LED has become shorted, TX1 and TX2 interrupt flags indicating if either of the TX inputs have been triggered, an NTC flag indicating the LED has experienced an over temperature condition, and a VIN Monitor flag indicating the input voltage has fallen below the VIN Monitor threshold.

The LM3561 is available in a tiny (1.215mm × 1.615mm × 0.6mm) 12-bump DSBGA and operates over the temperature range -40°C to +85°C.

**Table 1. Application Circuit Component List**

Component	Manufacturer	Value	Part Number	Size (mm)	Rating
L	TDK	1μH	MLP2520-1R0	2x2.5x1.2	1.5A
COU	Murata	10μF	GRM188R60J106M	1.6x0.8x0.8 (0603)	6.3V
CIN	Murata	10μF	GRM188R60J106M	1.6x0.8x0.8 (0603)	6.3V
LEDs	Lumiled	3.6V@1A	LXCL-PWF4		1.5A

## Connection Diagram

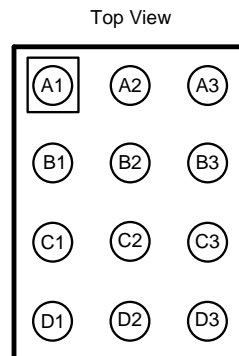

**Figure 3. DSBGA Package**  
see package number YFQ0012AAA

**Table 2. Pin Descriptions**

Name	Pin	Description
GND	A1	Ground
IN	A2	Input Voltage Connection. Connect IN to the input supply and bypass to GND with a minimum 10 $\mu$ F ceramic capacitor.
HWEN	A3	Active Low Hardware Reset Input. This input is high impedance and cannot be left floating. Typically this would be tied to a pullup resistor and to a logic high voltage, or VIN, in order to enable the LM3561.
SW	B1	Drain Connection for Internal NMOS and Synchronous PMOS Switches
STROBE	B2	Active High Hardware Flash Enable. Drive STROBE high to turn on the Flash pulse. STROBE has an internal 300k $\Omega$ pulldown to GND.
SCL	B3	Serial Clock Input.
OUT	C1	Step-Up DC/DC Converter Output. Bypass OUT to GND with a 10 $\mu$ F Ceramic Capacitor.
TX1/TORCH/GPIO	C2	Configurable as a Flash Interrupt Input, a Hardware Torch Enable, or a Programmable General Purpose Logic Input/Output. This pin has an internal 300k $\Omega$ pulldown to GND.
SDA	C3	Serial Data Input/Output.
LED	D1	High Side Current Source Output for Flash LED.
LEDI/NTC	D2	Configurable as a High Side Current Source Output for Indicator LEDs or as a Threshold Detector for LED Temperature Sensing.
TX2/GPIO2/INT	D3	Configurable as a Flash Interrupt Input, a Programmable General Purpose Logic Input/Output, or as an Interrupt output for fault notification. This pin has an internal 300k $\Omega$ pulldown to GND.



These devices have limited built-in ESD protection. The leads should be shorted together or the device placed in conductive foam during storage or handling to prevent electrostatic damage to the MOS gates.

### Absolute Maximum Ratings<sup>(1) (2)(3)</sup>

V <sub>IN</sub> , V <sub>SW</sub> , V <sub>OUT</sub>	-0.3V to 6V
V <sub>SCL</sub> , V <sub>SDA</sub> , V <sub>HWEN</sub> , V <sub>STROBE</sub> , V <sub>TX1</sub> , V <sub>TX2</sub> , V <sub>LED</sub> , V <sub>LEDI/NTC</sub>	-0.3V to (V <sub>IN</sub> +0.3V) w/ 6.0V max
Continuous Power Dissipation <sup>(4)</sup>	Internally Limited
Junction Temperature (T <sub>J-MAX</sub> )	+150°C
Storage Temperature Range	-65°C to +150°C
Maximum Lead Temperature (Soldering)	See <sup>(5)</sup>

- (1) Absolute Maximum Ratings indicate limits beyond which damage to the device may occur. Operating Ratings are conditions under which operation of the device is ensured. Operating Ratings do not imply ensured performance limits. For ensured performance limits and associated test conditions, see the Electrical Characteristics table.
- (2) All voltages are with respect to the potential at the GND pin.
- (3) If Military/Aerospace specified devices are required, please contact the TI Sales Office/Distributors for availability and specifications.
- (4) Internal thermal shutdown circuitry protects the device from permanent damage. Thermal shutdown engages at T<sub>J</sub>=150°C (typ.) and disengages at T<sub>J</sub>=135°C (typ.).
- (5) For detailed soldering specifications and information, see Application Note 1112: Micro SMD Wafer Level chip Scale Package [SNVA009](#)

### Operating Ratings<sup>(1) (2)</sup>

V <sub>IN</sub>	2.5V to 5.5V
Junction Temperature (T <sub>J</sub> )	-40°C to +125°C
Ambient Temperature (T <sub>A</sub> ) <sup>(3)</sup>	-40°C to +85°C

- (1) Absolute Maximum Ratings indicate limits beyond which damage to the device may occur. Operating Ratings are conditions under which operation of the device is ensured. Operating Ratings do not imply ensured performance limits. For ensured performance limits and associated test conditions, see the Electrical Characteristics table.
- (2) All voltages are with respect to the potential at the GND pin.
- (3) In applications where high power dissipation and/or poor package thermal resistance is present, the maximum ambient temperature may have to be derated. Maximum ambient temperature (T<sub>A-MAX</sub>) is dependent on the maximum operating junction temperature (T<sub>J-MAX-OP</sub> = +125°C), the maximum power dissipation of the device in the application (P<sub>D-MAX</sub>), and the junction-to-ambient thermal resistance of the part/package in the application ( $\theta_{JA}$ ), as given by the following equation:  $T_{A-MAX} = T_{J-MAX-OP} - (\theta_{JA} \times P_{D-MAX})$ .

## Thermal Properties

Junction-to-Ambient Thermal Resistance ( $\theta_{JA}$ ) <sup>(1)</sup>	68°C/W
-------------------------------------------------------------------------	--------

- (1) Junction-to-ambient thermal resistance ( $\theta_{JA}$ ) is taken from a thermal modeling result, performed under the conditions and guidelines set forth in the JEDEC standard JESD51-7. The test board is a 4-layer FR-4 board measuring 102mm x 76mm x 1.6mm with a 2x1 array of thermal via's. The ground plane on the board is 50mm x 50mm. Thickness of copper layers are 36 $\mu$ m/18 $\mu$ m/18 $\mu$ m/36 $\mu$ m (1.5oz/1oz/1oz/1.5oz). Ambient temperature in simulation is 22°C, still air. Power dissipation is 1W.

## Electrical Characteristics

Limits in standard typeface are for  $T_A = +25^\circ\text{C}$ . Limits in **boldface** type apply over the full operating ambient temperature range ( $-40^\circ\text{C} \leq T_A \leq +85^\circ\text{C}$ ). Unless otherwise specified,  $V_{IN} = 3.6\text{V}$ ,  $V_{HWEN} = V_{IN}$ .<sup>(1) (2)</sup>

Parameter	Test Conditions	Min	Typ	Max	Unit		
<b>Current Source Specifications</b>							
$I_{LED}$	Current source accuracy	600mA Flash LED Setting, $V_{OUT} = 4.5\text{V}$ , $3\text{V} \leq V_{IN} \leq 4.2\text{V}$	$-40^\circ\text{C} \leq T_A \leq +85^\circ\text{C}$	<b>-5%</b>	600	<b>+6%</b>	mA
			$T_A = +25^\circ\text{C}$	<b>-3%</b>	600	<b>+6%</b>	
		18mA Torch Current Setting, $V_{OUT} = 4.5\text{V}$ , $3\text{V} \leq V_{IN} \leq 4.2\text{V}$		<b>-10%</b>	18	<b>+10%</b>	
$V_{HR}$	Current Source Regulation Voltage ( $V_{OUT} - V_{LED}$ )	600mA setting, $V_{OUT} = 4.5\text{V}$			240		mV
<b>Step-Up DC/DC Converter Specifications</b>							
$V_{OVP}$	Output over-voltage protection trip point <sup>(3)</sup>	On Threshold		<b>4.90</b>	5	<b>5.05</b>	V
		Off Threshold			4.88		
$R_{PMOS}$	PMOS switch on-resistance	$I_{PMOS} = 500\text{mA}$			270		m $\Omega$
$R_{NMOS}$	NMOS switch on-resistance	$I_{NMOS} = 500\text{mA}$			250		m $\Omega$
$I_{CL}$	Switch current limit <sup>(4)</sup>	$3.0\text{V} \leq V_{IN} \leq 4.2\text{V}$	Flash Duration Register Bit [5] = 0	<b>0.88</b>	1	<b>1.12</b>	A
			Flash Duration Register Bit [5] = 1	<b>1.35</b>	1.5	<b>1.65</b>	
$I_{OUT\_SC}$	Output short circuit current limit	$V_{OUT} < 2.3\text{V}$			200		mA
$I_{LED/NTC}$	Indicator current	Indicator Register = 0xFF, $V_{LED/NTC} = 2\text{V}$ , $2.7\text{V} \leq V_{IN} \leq 4.2\text{V}$		<b>16</b>	18	<b>20</b>	mA
$V_{TRIP}$	Comparator trip threshold	Configuration Register 1 Bit [4] = 1, $3.0\text{V} \leq V_{IN} \leq 4.2\text{V}$		<b>0.97</b>	1	<b>1.03</b>	V
$f_{SW}$	Switching frequency	$2.7\text{V} \leq V_{IN} \leq 5.5\text{V}$		<b>1.8</b>	2	<b>2.2</b>	MHz
$t_{TIMEOUT}$	Timeout duration <sup>(5), (6)</sup>	$2.7\text{V} \leq V_{IN} \leq 5.5\text{V}$		<b>-10</b>		<b>+10</b>	%
$I_Q$	Quiescent supply current into IN	Device Not Switching			676		$\mu\text{A}$
		Device Switching			1140		
		Indicate Mode, Indicator Register = 0x07			560		
$I_{SHDN}$	Shutdown supply current	$2.7\text{V} \leq V_{IN} \leq 5.5\text{V}$ , HWEN = GND			0.02	<b>1</b>	$\mu\text{A}$

- (1) All voltages are with respect to the potential at the GND pin.
- (2) Min and Max limits are specified by design, test, or statistical analysis. Typical (Typ) numbers are not ensured, but do represent the most likely norm. Unless otherwise specified, conditions for typical specifications are:  $V_{IN} = 3.6\text{V}$  and  $T_A = +25^\circ\text{C}$ .
- (3) The typical curve for Over-Voltage Protection (OVP) is measured in closed loop using the typical application circuit. The OVP value is found by forcing an open circuit in the LED current path and recording the peak value of  $V_{OUT}$ . The value given in the Electrical Table is found in an open loop configuration by ramping the voltage at OUT until the OVP comparator trips. The closed loop data can appear higher due to the stored energy in the inductor being dumped into the output capacitor after the OVP comparator trips. This results in an open circuit condition where the output voltage can continue to rise after the OVP comparator trips by approximately  $I_{IN} \times \sqrt{L/C_{OUT}}$ .
- (4) The typical curve for Current Limit is measured in closed loop using the typical application circuit by increasing  $I_{OUT}$  until the peak inductor current stops increasing. The value given in the Electrical Table is measured open loop and is found by forcing current into SW until the current limit comparator threshold is reached. Closed loop data appears higher due to the delay between the comparator trip point and the NFET turning off. This delay allows the closed loop inductor current to ramp higher after the trip point by approximately  $40\text{ns} \times V_{IN}/L$ .
- (5) Specified by design. Not production tested.
- (6) The timeout duration period is a divided down representation of the 2MHz clock and thus the accuracy spec. is the same as the switching frequency. This accuracy specification applies to all settings in [Table 10](#).

## Electrical Characteristics (continued)

Limits in standard typeface are for  $T_A = +25^\circ\text{C}$ . Limits in **boldface** type apply over the full operating ambient temperature range ( $-40^\circ\text{C} \leq T_A \leq +85^\circ\text{C}$ ). Unless otherwise specified,  $V_{IN} = 3.6\text{V}$ ,  $V_{HWEN} = V_{IN}$ .<sup>(1) (2)</sup>

Parameter		Test Conditions	Min	Typ	Max	Unit
$I_{STBY}$	Standby supply current	$2.7\text{V} \leq V_{IN} \leq 5.5\text{V}$ , HWEN = IN, Enable Register bit [1:0] = 00		1.1	<b>2.3</b>	$\mu\text{A}$
$t_{TX}$	Flash-to-torch LED current settling time	TX_ Low-to-High, $I_{LED} = 600\text{mA}$ to $93.2\text{mA}$		2		$\mu\text{s}$
	Torch-to-flash LED current settling time	TX_ Low-to-High, $I_{LED} = 93.2\text{mA}$ to $600\text{mA}$		80		
$V_{IN\_TH}$	VIN monitor trip threshold	$V_{IN}$ Falling, VIN Monitor Register = 0x01 (Enabled with $V_{IN\_TH} = 2.9\text{V}$ )	<b>2.84</b>	2.90	<b>2.95</b>	V
<b>HWEN, STROBE, TX1/TORCH/GPIO1, TX2/INT/GPIO2 Voltage Specifications</b>						
$V_{IL}$	Input logic low	$2.7\text{V} \leq V_{IN} \leq 5.5\text{V}$	<b>0</b>		<b>0.4</b>	V
$V_{IH}$	Input logic high	$2.7\text{V} \leq V_{IN} \leq 5.5\text{V}$	<b>1.2</b>		<b><math>V_{IN}</math></b>	V
$V_{OL}$	Output logic low (GPIO1, GPIO2, INT)	$I_{LOAD} = 3\text{mA}$ , $2.7\text{V} \leq V_{IN} \leq 5.5\text{V}$			<b>0.4</b>	V
$R_{TX1}$	Internal pulldown resistance at TX1/TORCH/GPIO1			300		$\text{k}\Omega$
$R_{TX2}$	Internal pulldown resistance at TX2/GPIO2			300		$\text{k}\Omega$
$R_{STROBE}$	Internal pulldown resistance at STROBE			300		$\text{k}\Omega$
<b>I<sup>2</sup>C-Compatible Voltage Specifications (SCL, SDA)</b>						
$V_{IL}$	Input Logic Low	$2.7\text{V} \leq V_{IN} \leq 5.5\text{V}$	<b>0</b>		<b>0.4</b>	V
$V_{IH}$	Input Logic High	$2.7\text{V} \leq V_{IN} \leq 5.5\text{V}$	<b>1.3</b>		<b><math>V_{IN}</math></b>	V
$V_{OL}$	Output Logic Low (SDA)	$I_{LOAD} = 3\text{mA}$ , $2.7\text{V} \leq V_{IN} \leq 5.5\text{V}$			<b>400</b>	mV
<b>I<sup>2</sup>C-Compatible Timing Specifications (SCL, SDA)<sup>(5)</sup> see Figure 4</b>						
$f_{SCL}$	SCL(Clock Frequency)		<b>0</b>		<b>400</b>	kHz
$t_{RISE}^{(7)}$	Rise Time of Both SDA and SCL		<b><math>20 + 0.1 \times C_{BUS}</math></b>		<b>300</b>	ns
$t_{FALL}^{(8)}$	Fall Time of Both SDA and SCL		<b><math>20 + 0.1 \times C_{BUS}</math></b>		<b>300</b>	ns
$t_{LOW}$	Low Period of SCL Clock		<b>1.3</b>			$\mu\text{s}$
$t_{HIGH}$	High Period of SCL Clock		<b>600</b>			ns
$t_{HD;STA}$	Hold Time for Start (or Repeated Start) Condition		<b>600</b>			ns
$t_{SU;STA}$	Set-up Time for a Repeated Start		<b>600</b>			ns
$t_{HD;DAT}$	Data Hold Time		<b>0</b>			ns
$t_{SU;DAT}$	Data Setup Time		<b>100</b>			ns
$t_{SU;STO}$	Set-up Time for Stop Condition		<b>600</b>			ns
$t_{VD;DAT}$	Data Valid Time				<b>900</b>	ns
$t_{VD;ACK}$	Data Valid Acknowledge Time				<b>900</b>	ns
$t_{BUF}$	Bus Free Time Between a Start and a Stop Condition		<b>1.3</b>			$\mu\text{s}$

(7) Min rise and fall times on SDA and SCL can typically be less than 20ns.

(8) Min rise and fall times on SDA and SCL can typically be less than 20ns.

I<sup>2</sup>C TIMING

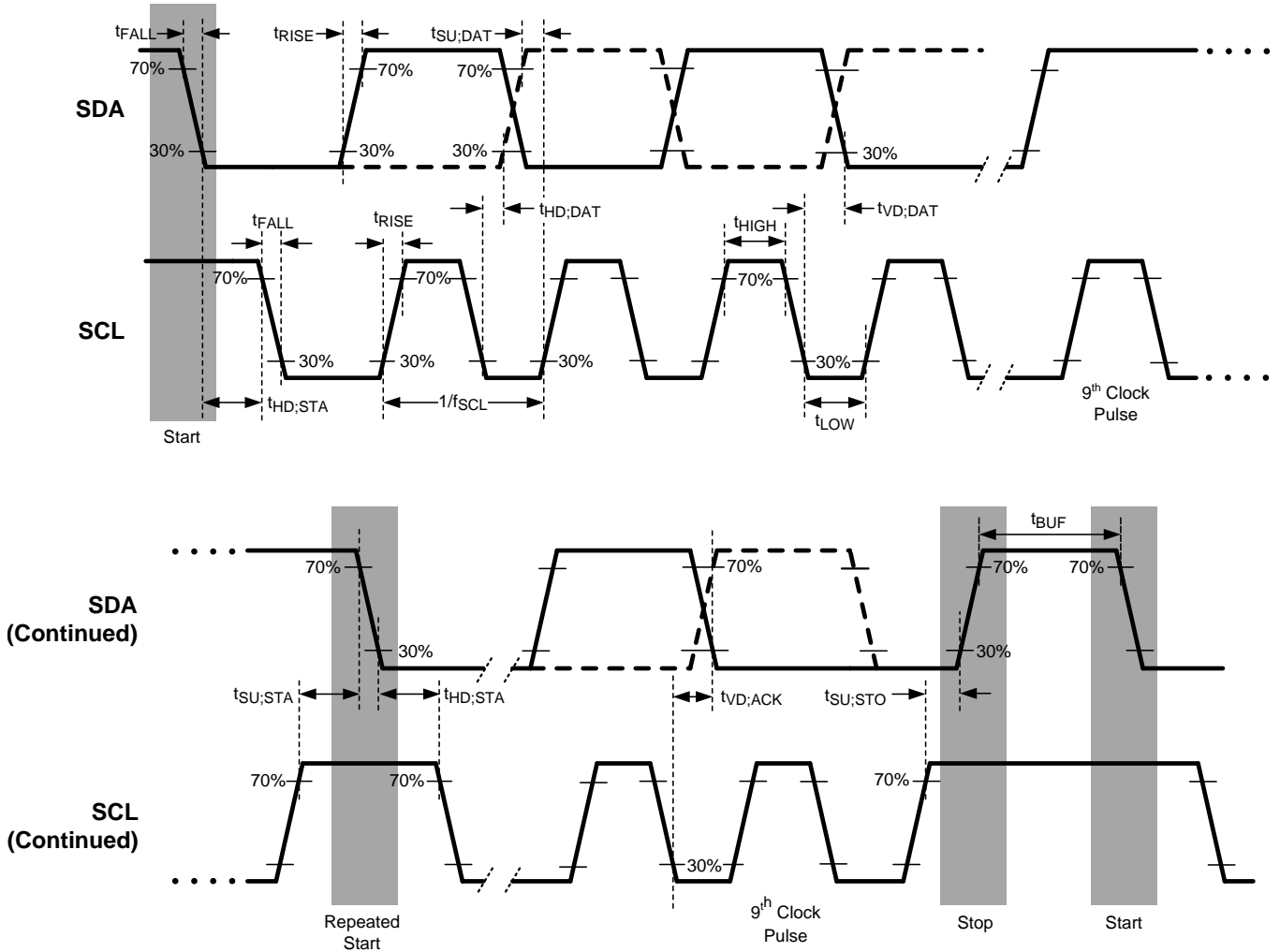

Figure 4. I<sup>2</sup>C Timing

### Typical Performance Characteristics

$V_{IN} = 3.6V$ , LEDs are Lumiled PWF-4,  $C_{OUT} = 10\mu F$ ,  $C_{IN} = 10\mu F$ ,  $L = MLP2520-1R0$  ( $1\mu H$ ,  $R_L = 0.085\Omega$ ),  $T_A = +25^\circ C$  unless otherwise specified.

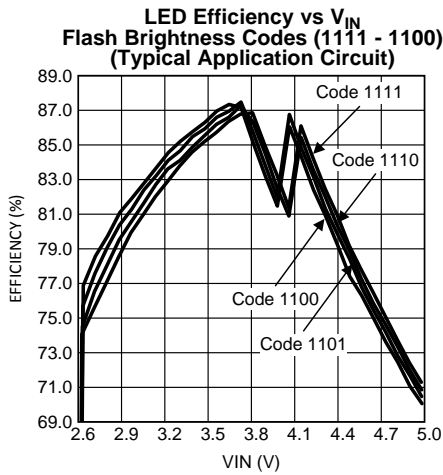

Figure 5.

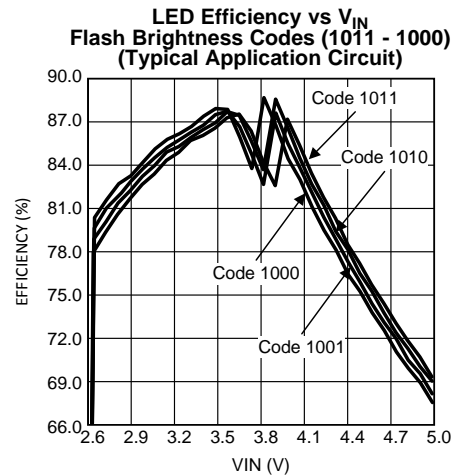

Figure 6.

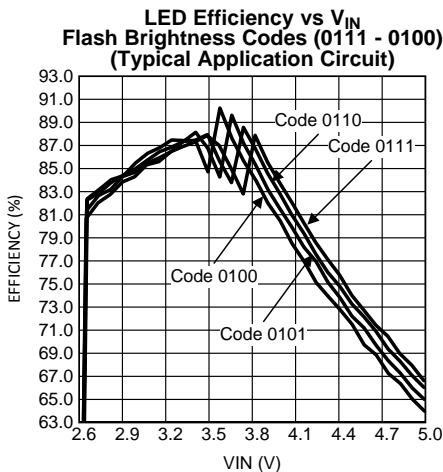

Figure 7.

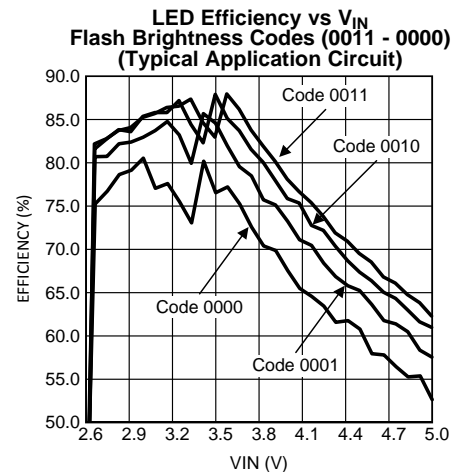

Figure 8.

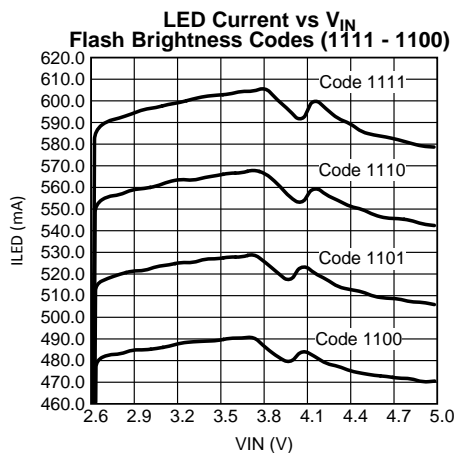

Figure 9.

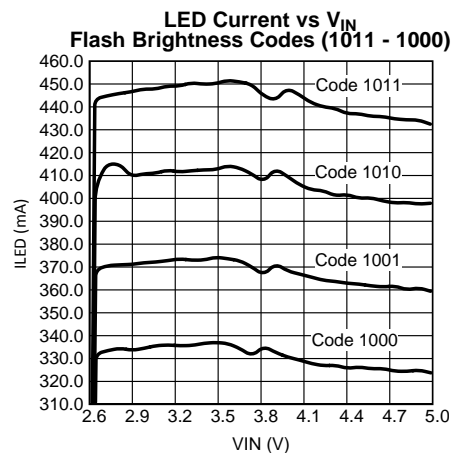

Figure 10.

**Typical Performance Characteristics (continued)**

$V_{IN} = 3.6V$ , LEDs are Lumiled PWF-4,  $C_{OUT} = 10\mu F$ ,  $C_{IN} = 10\mu F$ ,  $L = MLP2520-1R0$  ( $1\mu H$ ,  $R_L = 0.085\Omega$ ),  $T_A = +25^\circ C$  unless otherwise specified.

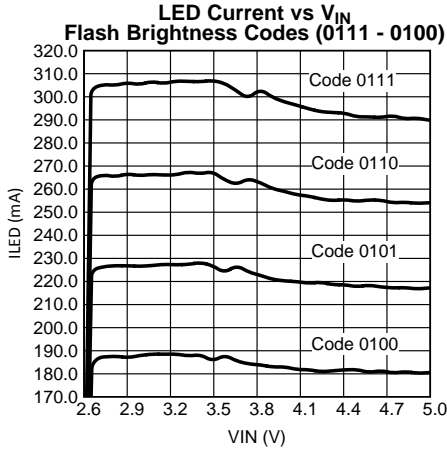

Figure 11.

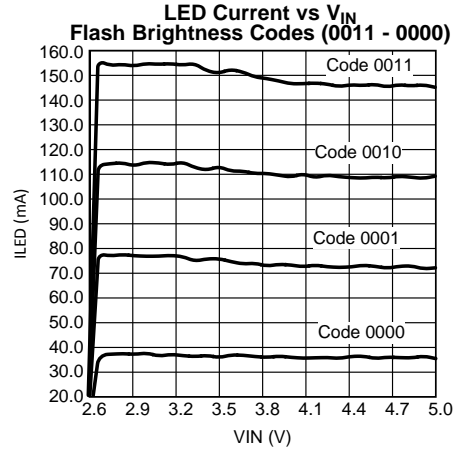

Figure 12.

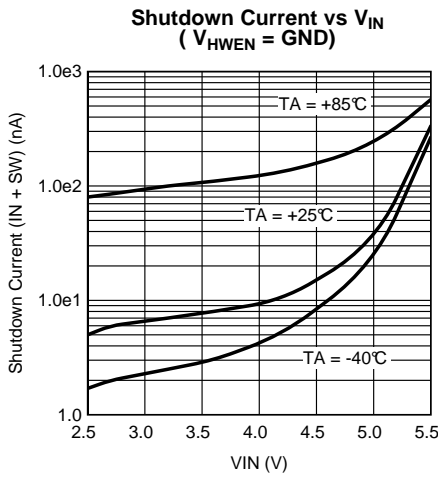

Figure 13.

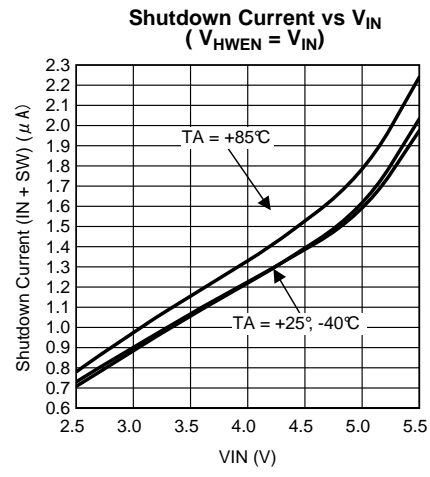

Figure 14.

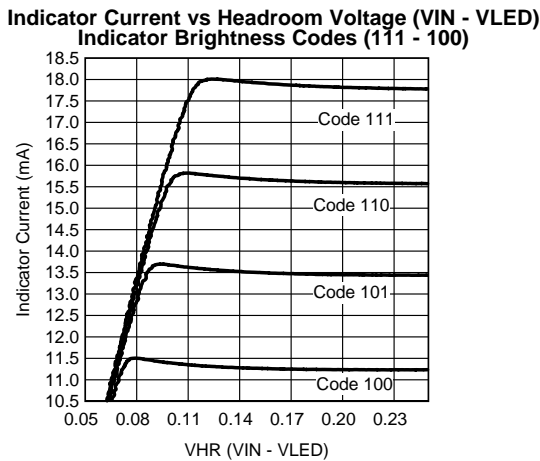

Figure 15.

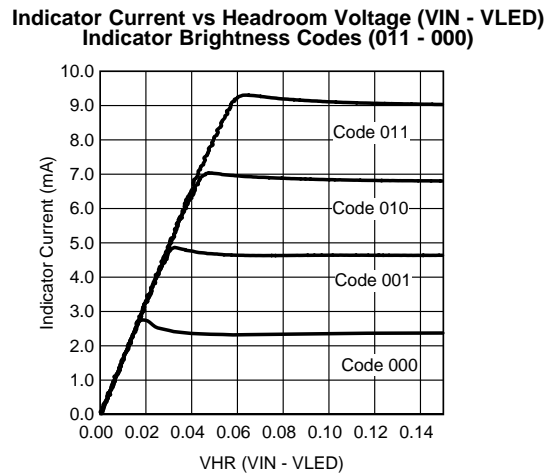

Figure 16.

Typical Performance Characteristics (continued)

$V_{IN} = 3.6V$ , LEDs are Lumiled PWF-4,  $C_{OUT} = 10\mu F$ ,  $C_{IN} = 10\mu F$ ,  $L = MLP2520-1R0$  ( $1\mu H$ ,  $R_L = 0.085\Omega$ ),  $T_A = +25^\circ C$  unless otherwise specified.

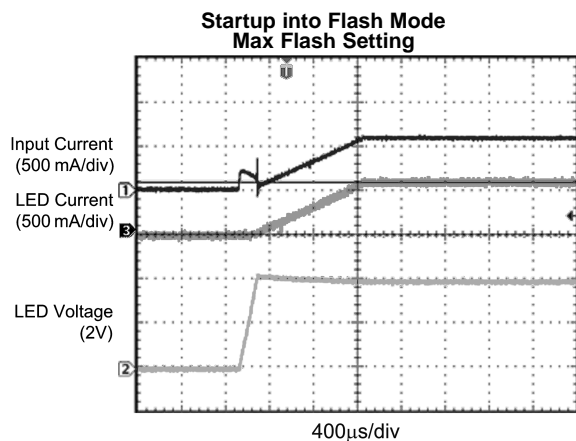

Figure 17.

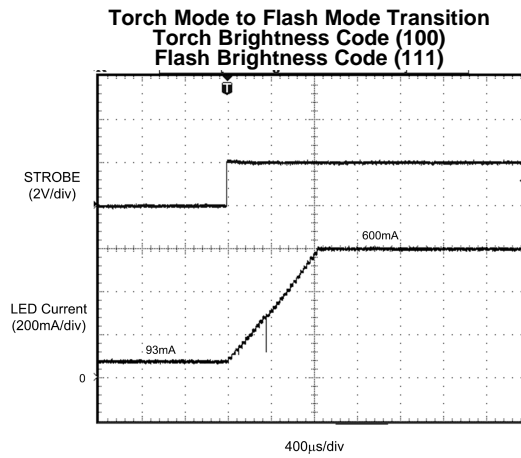

Figure 18.

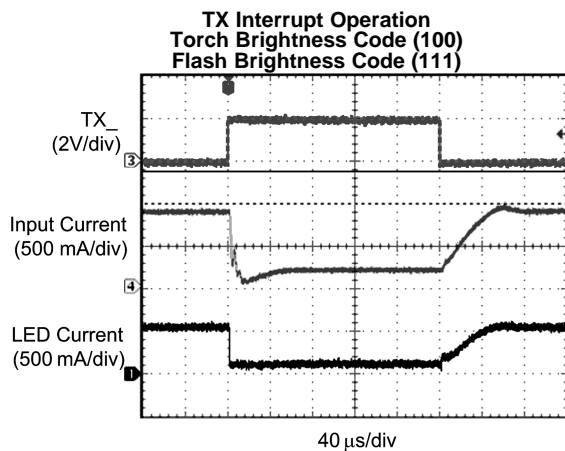

Figure 19.

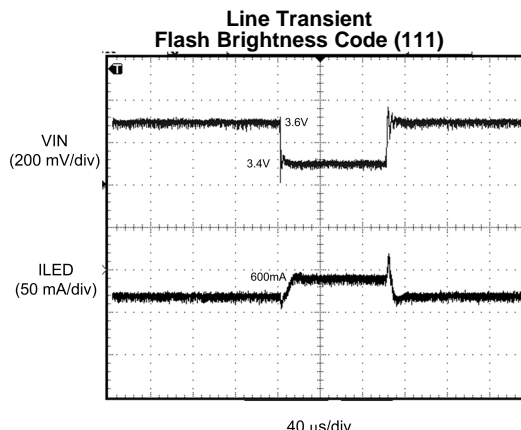

Figure 20.

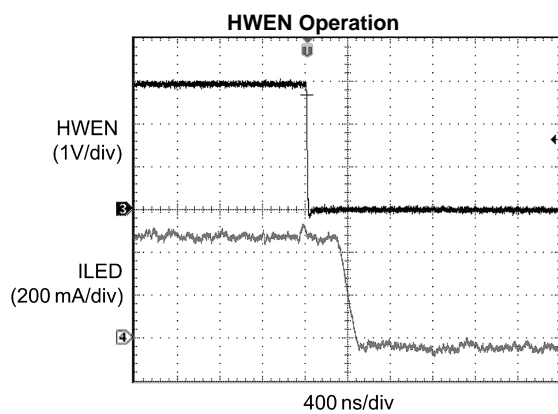

Figure 21.

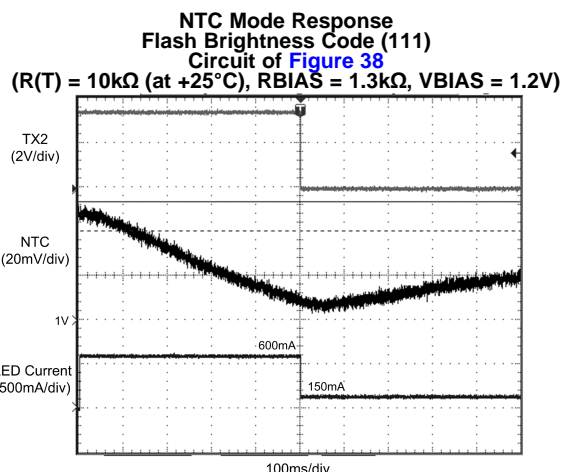
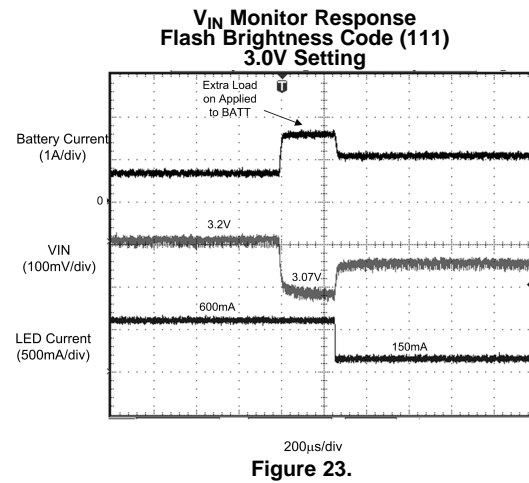

Figure 22.

### Typical Performance Characteristics (continued)

$V_{IN} = 3.6V$ , LEDs are Lumiled PWF-4,  $C_{OUT} = 10\mu F$ ,  $C_{IN} = 10\mu F$ ,  $L = MLP2520-1R0$  ( $1\mu H$ ,  $R_L = 0.085\Omega$ ),  $T_A = +25^\circ C$  unless otherwise specified.



BLOCK DIAGRAM

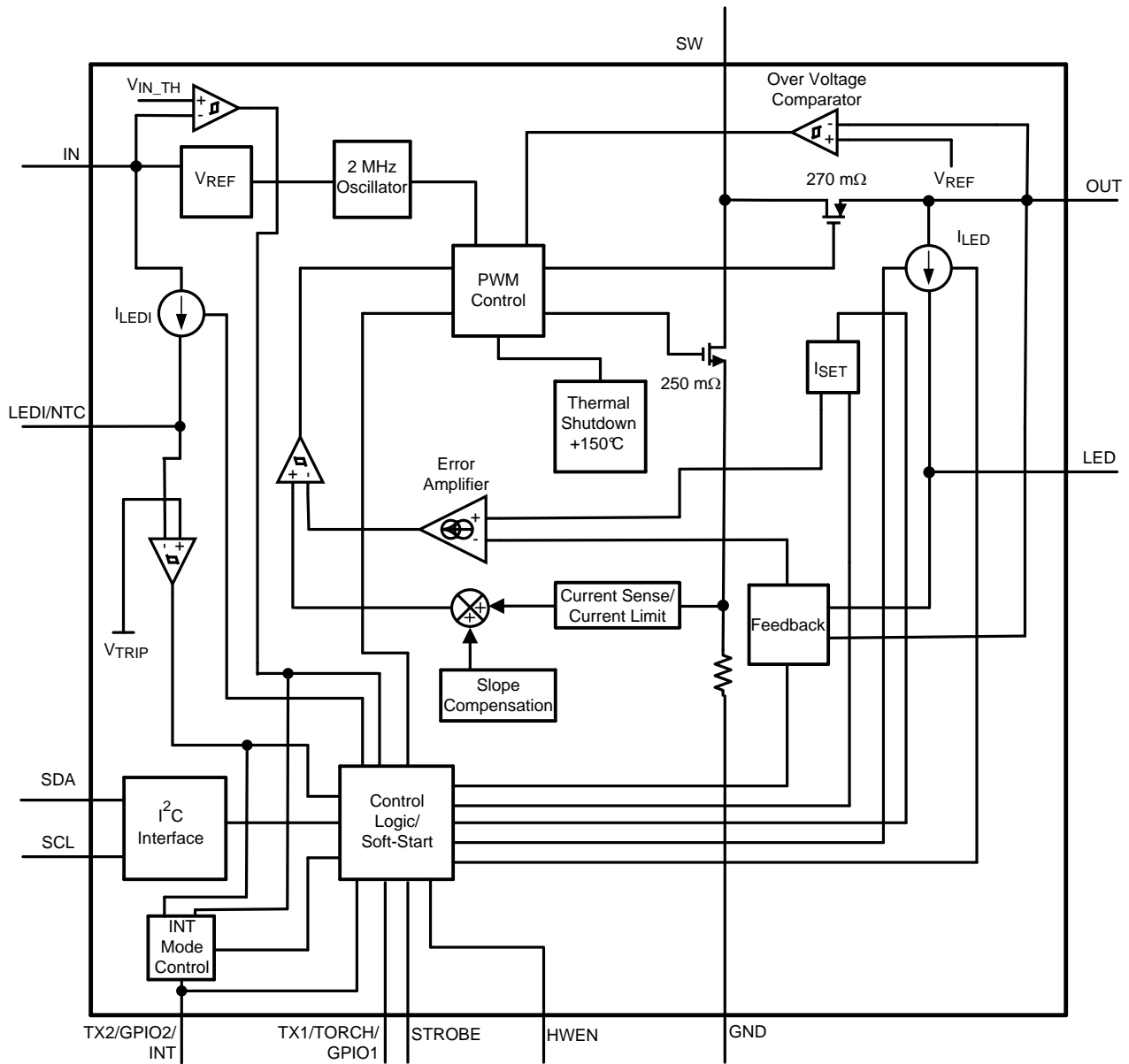

Figure 24. Block Diagram

## DETAILED DESCRIPTION

### Circuit Description

#### OVERVIEW

The LM3561 is a high power white LED flash driver capable of delivering up to 600mA of LED current into a single white LED. The device incorporates a 2MHz constant frequency, synchronous boost converter, and a high side current source to regulate the LED current over the 2.5V to 5.5V input voltage range.

When the LM3561 is enabled and the output voltage is greater than  $V_{IN} - 150\text{mV}$ , the PWM converter switches and maintains at least 250mV ( $V_{HR}$ ) across the current source ( $V_{OUT} - V_{LED}$ ). This minimum headroom voltage ensures that the current sinks remain in regulation. When the input voltage is above  $V_{LED} + V_{HR}$  the device operates in pass mode with the device not switching and the PFET on continuously. In pass mode the difference between  $(V_{IN} - I_{LED} \times R_{ON\_P})$  and  $V_{LED}$  is dropped across the current source. If the device is operating in pass mode and  $V_{IN}$  drops to a point that forces the device into switching, the LM3561 will make a one-time decision to jump into switching mode. The LM3561 remains in switching mode until the device is shutdown and re-enabled. This is true even if  $V_{IN}$  were to rise back above  $V_{LED} + 250\text{mV}$  during the active Flash or Torch cycle. This prevents the LED current from oscillating back and forth between pass and boost mode when  $V_{IN}$  is close to  $V_{OUT}$ .

The main features of the LM3561 include: dual TX inputs (TX1 and TX2) for forcing the device into a lower current state during high battery current conditions, a hardware flash enable input (STROBE), an active low shutdown input (HWEN), an input voltage monitor for detecting low battery voltage conditions, and a dual function pin that can be configured as a low power indicator LED current source or as a comparator input for LED thermal sensing via an external NTC thermistor.

Control of the LM3561 is done via an I<sup>2</sup>C-compatible interface. This includes: adjustment of the LED current in TORCH and FLASH mode, adjustment of the indicator LED current, programming the flash LED current timeout duration, and programming of the switch current limit. Additionally, there are 7 flag bits that can be read back indicating that the programmed flash current timeout has expired, a device over temperature condition has happened, an LED failure (open or short), an LED thermal failure (tripping of the internal NTC comparator), an input under voltage fault (VIN Monitor), and a separate flag for each TX input.

#### STARTUP

Turn on of the LM3561 via the I<sup>2</sup>C-compatible interface is done through bits [1:0] of the Enable Register. The device can be enabled in either Indicate mode, Torch mode, or Flash mode (see Table 4). On startup in Flash or Torch mode, when  $V_{OUT}$  is less than  $V_{IN}$ , the internal synchronous PFET turns on as a current source and delivers typically 200mA to the output capacitor. During this time the flash LED current source (LED) is off. When the voltage across the output capacitor reaches 2.3V the current source can turn on. At turn-on, the current source steps through each FLASH and TORCH level until the target LED current is reached (32 $\mu$ s/step). This gives the device a controlled turn-on and limits inrush current from the  $V_{IN}$  supply.

#### PASS MODE

On turn on, when the output voltage charges up to ( $V_{IN} - 150\text{mV}$ ), the LM3561 will decide if the part operates in Pass Mode or Boost mode. If the voltage difference between  $V_{OUT}$  and  $V_{LED}$  is less than 250mV, the device will transition into Boost Mode. If the difference between  $V_{OUT}$  and  $V_{LED}$  is greater than 250mV, the device will operate in Pass Mode. In Pass Mode the boost converter stops switching and the synchronous PFET turns fully on, bringing  $V_{OUT}$  up to  $(V_{IN} - I_{IN} \times R_{PMOS})$  where ( $R_{PMOS} = 240\text{m}\Omega$ ). In Pass Mode the inductor current is not limited by the peak current limit. In this situation the output current must be limited to 1.5A.

#### OVER-VOLTAGE PROTECTION

The output voltage is limited to typically 5V (4.9V min). In situations such as the current source open, the LM3561 will raise the output voltage in order to try and keep the LED current at its target value. When  $V_{OUT}$  reaches 5V, the over-voltage comparator will trip and turn off both the internal NFET and PFET switches. When  $V_{OUT}$  falls below 4.8V (typical) the LM3561 will begin switching again.

## CURRENT LIMIT

The LM3561 features 2 selectable current limits — 1A and 1.5A. These are selectable through the I<sup>2</sup>C-compatible interface via bit [5] of the Flash Duration Register. When the current limit is reached the LM3561 stops switching for the remainder of the switching cycle.

Since the current limit is sensed in the NMOS switch there is no mechanism to limit the current when the device operates in Pass Mode. In situations where there could potentially be large load currents at OUT, and the LM3561 is operating in Pass mode, the load current must be limited to 1.5A. In Boost mode or Pass mode if V<sub>OUT</sub> falls below approximately 2.3V the part stops switching and the PFET operates as a current source limiting the current to typically 200mA. This prevents damage to the LM3561 and excessive current draw from the battery during output short circuit conditions.

## THERMAL SHUTDOWN

The LM3561 features a thermal shutdown threshold of typically +150°C. When the die temperature reaches +150°C, the active current source (LED) will shutdown, and the TSD flag in the Flags register is written high. The device cannot be started up again until the Flags register is read back. Once the Flags register is read back the current source can be re-enabled into Torch, or Flash Mode. The thermal shutdown (TSD) circuitry has an internal 250μs de-glitch timer which helps prevent unwanted noise from falsely triggering a TSD event. However, when the LM3561 is in boost mode at higher flash currents, the de-glitch timer can get reset by the high currents in the LM3561's GND. As a result the thermal shutdown's internal de-glitch timer can get reset before the TSD event can get latched in. This causes a TSD event to not get triggered until the LM3561's flash pulse reaches the end of the flash duration, when the noisy currents have dropped to a lower level. However, once the noise is lower and a TSD event is triggered, the next flash pulse is not allowed until the flags register is read back. In pass mode the boost switcher is off and the lower noise environment allows the devices TSD circuitry to shutdown immediately when the die temperature reaches +150°C.

## FLASH MODE

In Flash mode the LED current source (LED) provides 16 different current levels from typically 36mA to 600mA. The Flash currents are set by writing to bits [3:0] of the Flash Brightness Resister. Flash mode is activated by either writing a (1, 1) to bits [1:0] of the Enable Register, or by pulling the STROBE pin high. Once the Flash sequence is activated the current source (LED) will ramp up to the programmed Flash current by stepping through all Torch and Flash levels (32μs/step) until the programmed current is reached.

## FLASH TERMINATION

Bit [2] of the Enable Register determines how the Flash pulse terminates. With this bit = '1' the Flash current pulse will only terminate by reaching the end of the Flash timeout period (see [Figure 29](#)). With STR = '0', Flash mode can be terminated by pulling STROBE low, programming bits [1:0] of the Enable Register with (0,0), or by allowing the Flash timeout period to elapse (see [Figure 28](#)). If STR = '0' and STROBE is toggled before the end of the Flash timeout period, the timeout period resets on the rising edge of STROBE. See [LM3561 Timing Diagrams](#) regarding the Flash pulse termination for the different STR bit settings.

After the Flash pulse terminates, either by a flash timeout, pulling STROBE low, or disabling it via the I<sup>2</sup>C-compatible interface, the current source (LED) turns completely off. This happens even when Torch is enabled via the I<sup>2</sup>C-compatible interface and the Flash pulse is turned on by toggling STROBE. After a Flash event ends (bits [1:0] of the Enable Register are automatically re-written with (0, 0).

## FLASH TIMEOUT

The Flash timeout period sets the maximum duration of the flash current pulse. Bits [4:0] of the Flash Duration Register programs the 32 different Flash timeout levels in steps of 32ms, giving a Flash timeout range of 32ms to 1024ms (see [Table 10](#)).

## TORCH MODE

In Torch mode the current source (LED) provides 8 different current levels (see [Table 8](#)). The Torch currents are adjusted by writing to bits [2:0] of the Torch Brightness Register. Torch mode is activated by setting Enable Register bits [1:0] to (1, 0). Once the Torch mode is enabled the current sources will ramp up to the programmed Torch current level by stepping through all of the Torch currents at (32μs/step) until the programmed Torch current level is reached.

## FLASH PULSE INTERRUPT (TX1), HARDWARE TORCH INPUT (TORCH) AND GENERAL PURPOSE I/O (GPIO1)

The TX1/TORCH/GPIO1 input has a triple function; either as a flash pulse interrupt (TX1), a hardware torch mode enable (TORCH), or as a general purpose I/O (GPIO1).

### **Flash Interrupt (TX1)**

With Configuration Register 1 Bit [7] = '0' (default), TX1/TORCH/GPIO1 is a flash pulse interrupt input. This is designed to force the flash pulse into a lower current state in order to reduce the current pulled from the battery during high battery current situations. For example, when the LM3561 is engaged in a Flash event and TX1 is pulled high (active high polarity) the current source (LED) is forced into Torch mode at the programmed Torch current setting. If TX1 is then pulled low before the Flash pulse terminates, the LED current will ramp back to the previous Flash current level. At the end of the Flash timeout, whether TX1 is high or low, the LED current will turn off.

### **TX1 Polarity**

In TX1 mode, TX1 can be programmed as an active low TX1 input where pulling TX1 to GND will cause a TX1 event. TX1 polarity inversion is done via Configuration Register 1 bit [5].

### **Hardware Torch Mode**

With Configuration Register 1 Bit [7] = '1', TX1/TORCH/GPIO1 is configured as a hardware Torch mode enable. In this mode (TORCH mode), a high at TORCH turns on the LED current at the programmed Torch current setting. The STROBE input and I<sup>2</sup>C Enabled flash take precedence over TORCH mode. In hardware torch mode, the LED current source will turn off after a flash event and Configuration Register 1 Bit [7] will be reset to '0'. In this situation, to re-enter torch mode via hardware torch, the hardware torch enable bit (Configuration Register 1 Bit [7]) must be reset to '1'. [Figure 26](#), [Figure 27](#), and [Figure 34](#) detail the functionality of the TX1/TORCH input.

### **GPIO1 Mode**

With GPIO Register bit[0] = '1', the TX1/TORCH/GPIO1 pin is configured as a general purpose I/O. In GPIO1 mode this pin can be either a logic input or a logic output depending on the bit settings in bits [2:1] of the GPIO Register (see [Table 6](#)).

## FLASH PULSE INTERRUPT (TX2), GENERAL PURPOSE I/O (GPIO2), AND INTERRUPT OUTPUT (INT)

The TX2/GPIO2/INT pin has a triple function: either a flash interrupt input (TX2), a general purpose I/O (GPIO2), or as an interrupt output (INT).

### **Flash Interrupt (TX2 Mode)**

In TX2 mode (default), TX2 is a flash pulse interrupt input. This is designed to force the flash pulse into a lower current state in order to reduce the current pulled from the battery during high battery current situations. For example, when the LM3561 is engaged in a Flash event, and TX2 is pulled high (active high polarity), the current source (LED) is forced into torch mode at the programmed Torch current setting. If TX2 is then pulled low before the flash pulse terminates, the LED current will step back to the previous flash current level. At the end of the flash timeout, whether the TX2 pin is high or low, the LED current will turn off. In addition to forcing torch mode with a TX2 event, the TX2 input can be set to force shutdown. Configuration Register 2 bit[0] sets this mode (see [Table 13](#)). In TX2 shutdown mode, a TX2 event will shut down the flash pulse. Once shut down, the flash pulse must be re-enabled via STROBE or the flash enable bits in the Enable Register.

### **TX2 Forcing Shutdown**

TX2 also has the capability to force shutdown (see [Figure 30](#)). When bit [0] of Configuration Register 2 is set to a '1', TX2 will force shutdown when active. For example, if TX2 is configured for TX2 mode with active high polarity, and bit [0] of Configuration Register 2 is set to '1' then when TX2 is driven high, (LED) will be forced into shutdown. Once the current source is forced into shutdown by activating TX2, the current source can only be re-enabled in flash mode if TX2 is pulled low, and the Flags register is read back. If only the Flags register is read back and TX2 is kept high, the device will be re-enabled into torch mode and not shutdown. This occurs because the TX2 shutdown feature is an edge-triggered event. With active high polarity the TX2 shutdown requires a rising edge at TX2 in order to force the current source back into shutdown. Once shut down, it takes a read back of the flags Register and another rising edge at TX2 to force shut down again.

### **TX2 Polarity**

In TX2 mode (default), TX2 is a flash pulse interrupt input. This is designed to force the flash pulse into a lower current state in order to reduce the current pulled from the battery during high battery current situations. For example, when the LM3561 is engaged in a Flash event and TX2 is pulled high (active high polarity) the current source (LED) is forced into torch mode at the programmed Torch current setting. If TX2 is then pulled low before the flash pulse terminates, the LED current will step back to the previous flash current level. At the end of the flash timeout, whether the TX2 pin is high or low, the LED current will turn off. In addition to forcing torch mode with a TX2 event, the TX2 input can be set to force shutdown. Configuration Register 2 bit[0] sets this mode (see [Figure 31](#)). In TX2 shutdown mode, a TX2 event will shutdown the flash pulse. Once shut down, the flash pulse must be re-enabled via STROBE or the flash enable bits in the Enable Register.

### **GPIO2 Mode**

The TX2/GPIO2/INT pin is configured as a general purpose logic input/output by setting GPIO Register bit[3] = '1'. In GPIO2 mode this pin can be either a logic input or output depending on the bit settings for GPIO Register bit [4] (see [Table 6](#)).

### **Interrupt Output Mode**

The TX2/GPIO2/INT pin is configured as an interrupt output by setting the TX2/GPIO2/INT as a GPIO output and setting bit [6] of the GPIO register to '1'. When in INT mode, the TX2/GPIO2/INT pin will pull low when either of the following occur:

1. The LM3561 is in NTC Mode, the LED current source is enabled, and  $V_{NTC}$  falls below  $V_{TRIP}$ .
2. The LM3561's Input Voltage Monitor is enabled and  $V_{IN}$  falls below  $V_{IN\_TH}$ .

### **INDICATOR LED/THERMISTOR (LEDI/NTC)**

The LEDI/NTC pin serves a dual function, either as an LED indicator driver or as a threshold detector for a negative temperature coefficient (NTC) thermistor circuit.

#### **Led Indicator Mode (LEDI)**

LEDI/NTC is configured as an LED indicator driver by setting Configuration Register 1 bit [4] = '0' (default). The indicator current source is enabled by setting Enable Register bits [1:0] = '01'. In Indicator mode there are 8 different current levels available (2.25mA - 18mA) which are programmed through the Indicator Register (see [Table 5](#)).

#### **Led Thermal Comparator (NTC Mode)**

Writing a '1' to Configuration Register 1 bit [4] disables the indicator current source and configures LEDI/NTC as a comparator input for monitoring an NTC thermistor circuit. In this mode LEDI/NTC becomes the negative input of an internal comparator, with the positive input internally connected to an internal reference ( $V_{TRIP} = 1V$ ). Additionally, Configuration Register 2 bit [1] determines the action NTC Mode takes if the voltage at LEDI/NTC falls below  $V_{TRIP}$ . With Configuration register 2 bit [1] = '0', the LED current source will be forced into Torch mode when the voltage at LEDI/NTC falls below  $V_{TRIP}$ . With Configuration Register 2 bit [1] = '1' the device will shut down the current source (LED) when  $V_{LEDI/NTC}$  falls below  $V_{TRIP}$ . When the LM3561 is forced from Flash to Torch, normal LED operation (during the same Flash pulse) can only be re-started by reading from the Flags

Register and ensuring the voltage at  $V_{LED/NTC}$  is above  $V_{TRIP}$ . When  $V_{LED/NTC}$  falls below  $V_{TRIP}$  and the Flags register is cleared, the LM3561 will go through a 250 $\mu$ s deglitch time before the flash current falls to either torch mode or goes into shutdown. This deglitch time prevents noise from inadvertently tripping the NTC comparator. For a more detailed description of this mode and designing the NTC circuit (see [NTC THERMISTOR SELECTION](#) section in the [Applications Information](#) section of this datasheet).

In NTC mode the NTC flag (see [Flags Register and Fault Indicators](#) section) can be output on the TX2/GPIO2/INT pin. This is accomplished by making the TX2/GPIO2/INT an interrupt output (see [Interrupt Output Mode](#) section).

### ALTERNATE EXTERNAL TORCH (AET MODE)

With Configuration Register 2 bit [2] set to '1' the operation of TX1/TORCH becomes dependent on its occurrence relative to STROBE. In this mode if TX1/TORCH goes high first, followed by STROBE going high, the LEDs are forced into torch mode with no timeout. In this mode if TX1/TORCH goes high *after* STROBE has gone high, then the TX1/TORCH pin operates as a normal flash interrupt, and the LEDs will turn off at the end of the timeout duration. (See LM3561 Timing Diagrams: [Figure 32](#) and [Figure 33](#)). AET mode can only be used with STROBE configured as a level sensitive input. Configuring STROBE for edge sensitive operation (STR bit = 1), will force TX1 to act as a simple flash interrupt.

### INPUT VOLTAGE MONITOR

The LM3561 has an internal comparator that monitors the voltage at IN and can force the LED current into torch mode or into shutdown if  $V_{IN}$  falls below the programmable VIN Monitor Threshold ( $V_{IN\_TH}$ ). Bit [0] in the VIN Monitor register enables or disables this feature. When enabled, Bits [2:1] program the 4 adjustable thresholds of 2.9V, 3V, 3.1V, and 3.2V. Bit [3] in Configuration Register 2 selects whether an under-voltage event forces Torch mode or forces the LED current source off. (See [Table 7](#) and [Table 13](#).)

When the VIN Monitor is active and  $V_{IN}$  falls below the programmed threshold ( $V_{IN\_TH}$ ) the LEDs will either turn off or their current will be reduced to the programmed Torch current setting. To reset the LED current to its previous level, two things must occur. First,  $V_{IN}$  must go above  $V_{IN\_TH}$ , and the Flags register must be read back.

In VIN Monitor mode the VIN Monitor Flag (see [Flags Register and Fault Indicators](#) section) can be output on the TX2/GPIO2/INT pin. This is accomplished by making the TX2/GPIO2/INT an interrupt output (see [Interrupt Output Mode](#) section).

### LM3561 Timing Diagrams

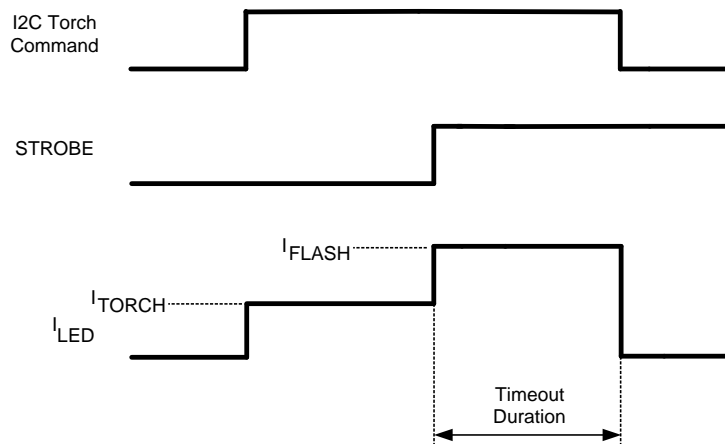

**Figure 25. Torch to Flash Operation**

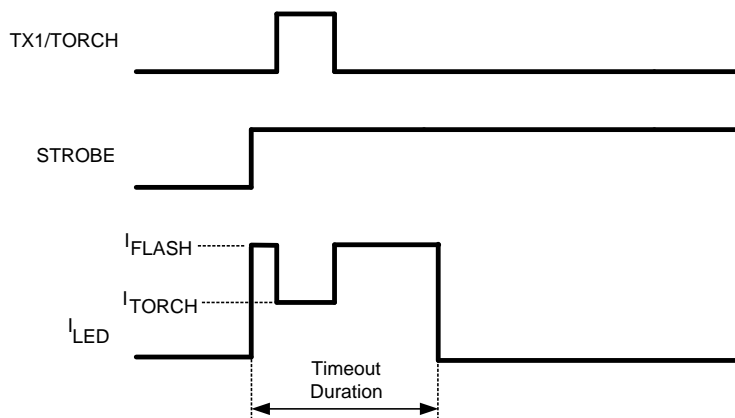

Figure 26. TX Event During a Flash Pulse (TX1/TORCH is an Active High TX Input)

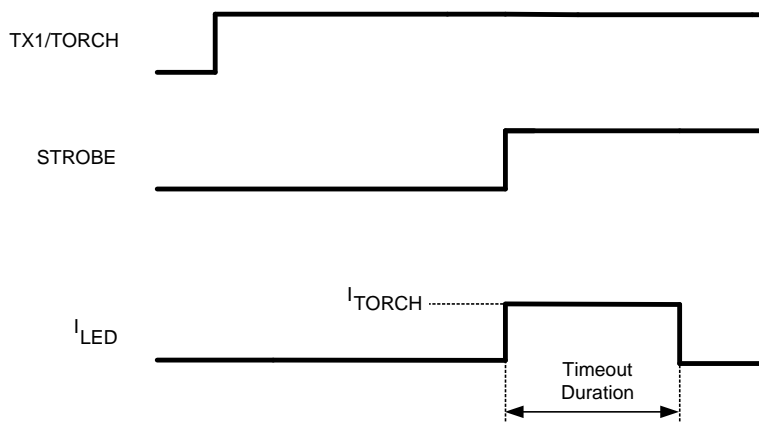

Figure 27. TX Event Before and After a Flash Event (TX1/TORCH is an Active High TX Input)

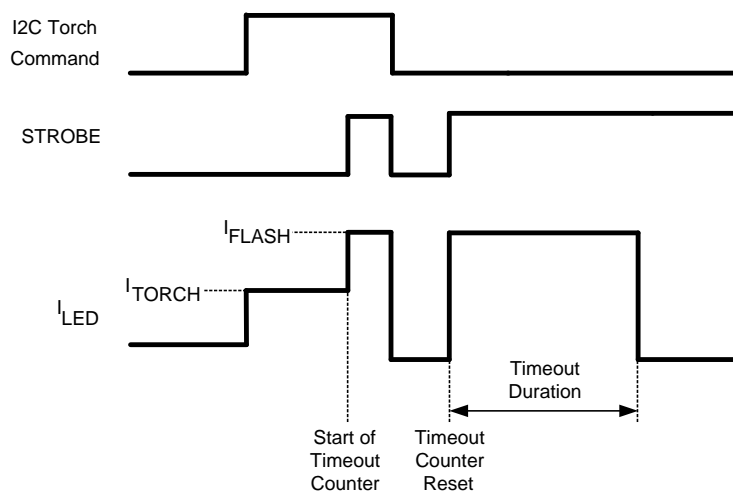
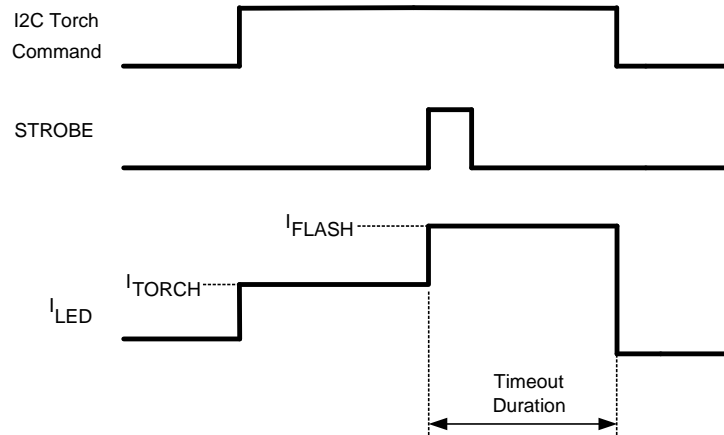
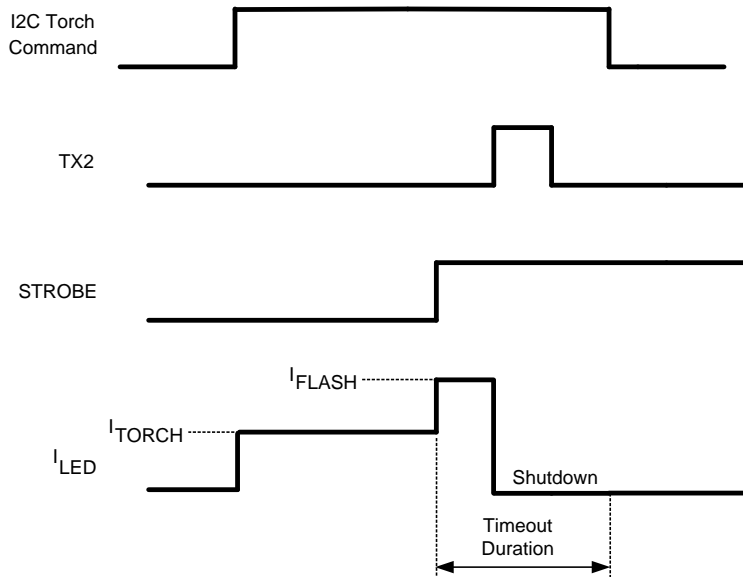

Figure 28. STROBE Input is Level Sensitive (Enable Register Bit [2] = '0')



**Figure 29. STROBE Input is Edge Sensitive (Enable Register Bit [2] = '1')**



**Figure 30. TX2 Configured as an Active High Flash Interrupt and Set to Force Shutdown**

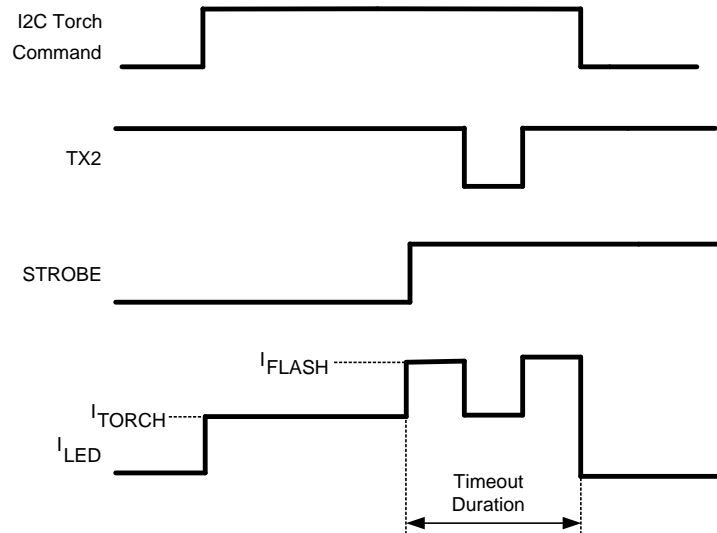

**Figure 31. TX2 Configured as an Active Low TX Input and Set to Force Torch Mode**

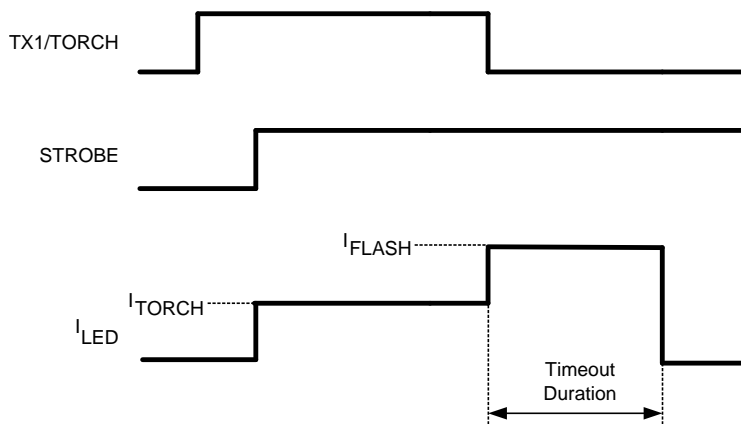

**Figure 32. Alternate External Torch Mode (TX1/TORCH Turns on Before STROBE; when TX1/TORCH goes low, Flash mode is initiated)**

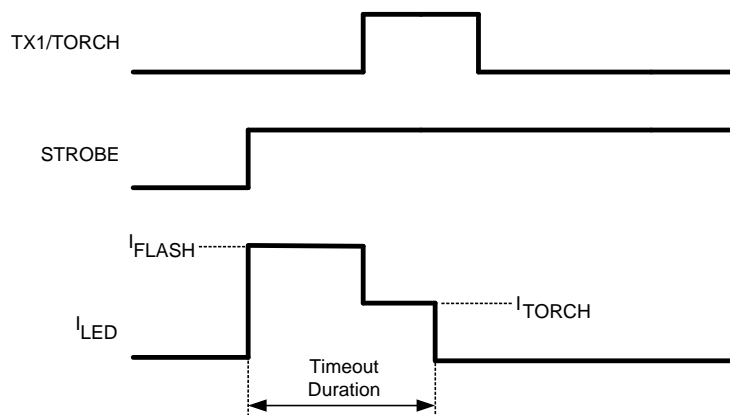

**Figure 33. Alternative External Torch Mode (STROBE Goes High Before TX1/TORCH, Same as Normal TX1 Operation)**

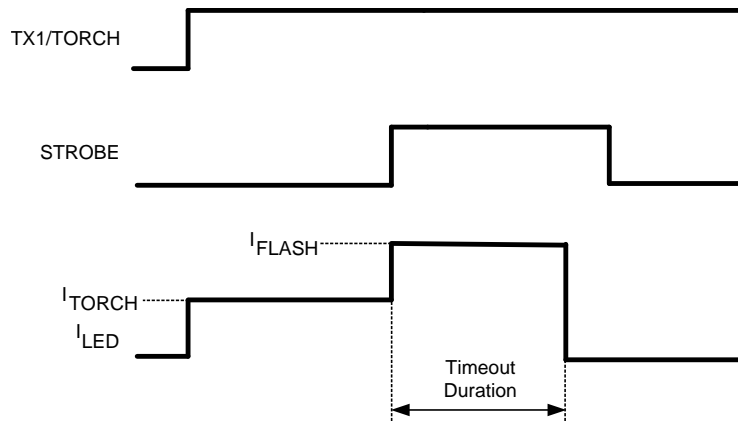

**Figure 34. TX1/TORCH Pin is Configured as a Hardware Torch Input**

## Flags Register and Fault Indicators

The Flags Register contains the Interrupt and Fault indicators. Seven flags are available in the Flags Register. These include a Flash Timeout flag (TO), a Thermal Shutdown flag (TSD), an LED Failure flag (LEDF), an LED Thermal flag (NTC), and a VIN Monitor flag. Additionally, two interrupt flag bits TX1 interrupt and TX2 interrupt indicate a change of state of the TX1/TORCH pin (TX1 mode) and TX2/GPIO2/INT pin (TX2 mode). Reading back a '1' indicates the TX lines have changed state since the last read of the Flags Register. A read of the Flags Register resets the flag bits.

### FLASH TIMEOUT

The Flash Timeout Flag (TO), (bit [0] of the Flags Register) reads back a '1' if the LM3561 is active in Flash Mode and the timeout period expires before the flash pulse is terminated. The flash pulse can be terminated before the timeout period expires by pulling the STROBE pin low (with STR bit '0'), or by writing a '0' to bits [1:0] of the Enable Register. The TO flag is reset to (0) by pulling HWEN low, removing power to the LM3561, reading the Flags Register, or when the next Flash pulse is triggered.

### THERMAL SHUTDOWN

When the LM3561's die temperature reaches +150°C the boost converter shuts down and the NFET and PFET turn off. Additionally, both current sources (LED and LEDI/NTC) turn off. When the thermal shutdown threshold is tripped a '1' gets written to bit [1] of the Flag Register (Thermal Shutdown bit). The LM3561 will start up again when the die temperature falls to below +135°C, the Flags Register is read back, and the device is re-enabled.

### LED FAULT

The LED Fault flag (bit 2 of the Flags Register) reads back a '1' if the part is active in Flash or Torch mode and the current source (LED) experiences an open or short condition. An LED open condition is signaled if the OVP threshold is crossed at OUT. An LED short condition is signaled if the voltage at LED goes below 500mV.

There is a delay of 250µs before the LEDF flag is valid on a LED short. This is the time from when  $V_{LED}$  falls below the LED short threshold of 500mV (typical) to when the fault flag is valid. There is a 2µs delay from when the LEDF flag is valid on an LED open. This delay is the time between when the OVP threshold is triggered and when the fault flag is valid. The LEDF flag can only be reset to (0) by pulling HWEN low, removing power to the LM3561, or reading the Flags Register.

### LED THERMAL FAULT

The NTC flag (bit [5] of the Flags Register) reads back a '1' if the LM3561 is active in Flash or Torch mode, the device is in NTC mode, and the voltage at LEDI/NTC has fallen below  $V_{TRIP}$  (1V typical). When this has happened and the LM3561 has been forced into Torch or LED shutdown, depending on the state of Configuration Register 2 bit [1], the voltage at LEDI/NTC must rise above the  $V_{TRIP}$  threshold and the Flags Register must be read in order to place the device back in normal operation. (see [Led Thermal Comparator \(NTC Mode\)](#) section for more details).

## INPUT VOLTAGE MONITOR FAULT

The  $V_{IN}$  Monitor Flag (bit [7] of the Flags Register) reads back a '1' when the Input Voltage Monitor is enabled and  $V_{IN}$  falls below the programmed ( $V_{IN\_TH}$ ). The input voltage must rise above  $V_{IN\_TH}$  and the Flags register must be read back in order to resume normal operation after the LED current has been forced to Torch mode or turned off due to a VIN Monitor event.

## TX1 AND TX2 INTERRUPT FLAGS

The TX1 and TX2 interrupt flags (bits [3] and [4] of the Flags register) indicate a TX event on the TX1 or TX2 pins. Bit 3 will read back a '1' if TX1/TORCH is in TX1 mode and the pin has changed from low to high since the last read of the Flags Register. Bit [4] will read back a '1' if TX2 is in TX2 mode and the pin has had a TX event since the last read of the Flags Register. A read of the Flags Register automatically resets these bits.

A TX event can be either a high to low transition or a low to high transition depending on the setting of the TX1 or TX2 polarity bits (see [Table 12](#)).

## I<sup>2</sup>C-Compatible Interface

### START AND STOP CONDITIONS

The LM3561 is controlled via an I<sup>2</sup>C-compatible interface. START and STOP conditions classify the beginning and end of the I<sup>2</sup>C session. A START condition is defined as SDA transitioning from HIGH to LOW while SCL is HIGH. A STOP condition is defined as SDA transitioning from LOW to HIGH while SCL is HIGH. The I<sup>2</sup>C master always generates the START and STOP conditions.

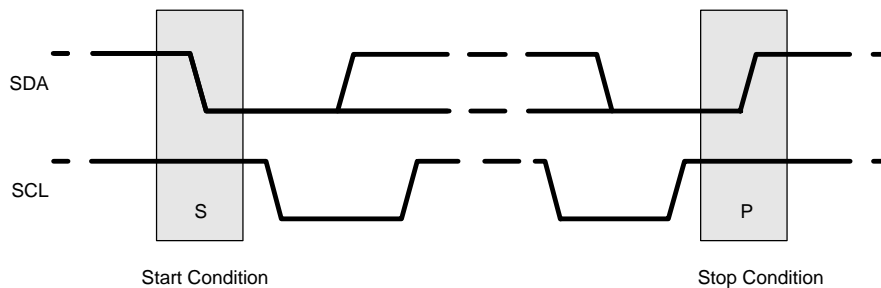

Figure 35. Start and Stop Sequences

The I<sup>2</sup>C bus is considered busy after a START condition and free after a STOP condition. During data transmission the I<sup>2</sup>C master can generate repeated START conditions. A START and a repeated START condition are equivalent function-wise. The data on SDA must be stable during the HIGH period of the clock signal (SCL). In other words, the state of SDA can only be changed when SCL is LOW. [Figure 4](#) and [Figure 36](#) show the SDA and SCL signal timing for the I<sup>2</sup>C-compatible Bus. See the Electrical Characteristics Table for timing values.

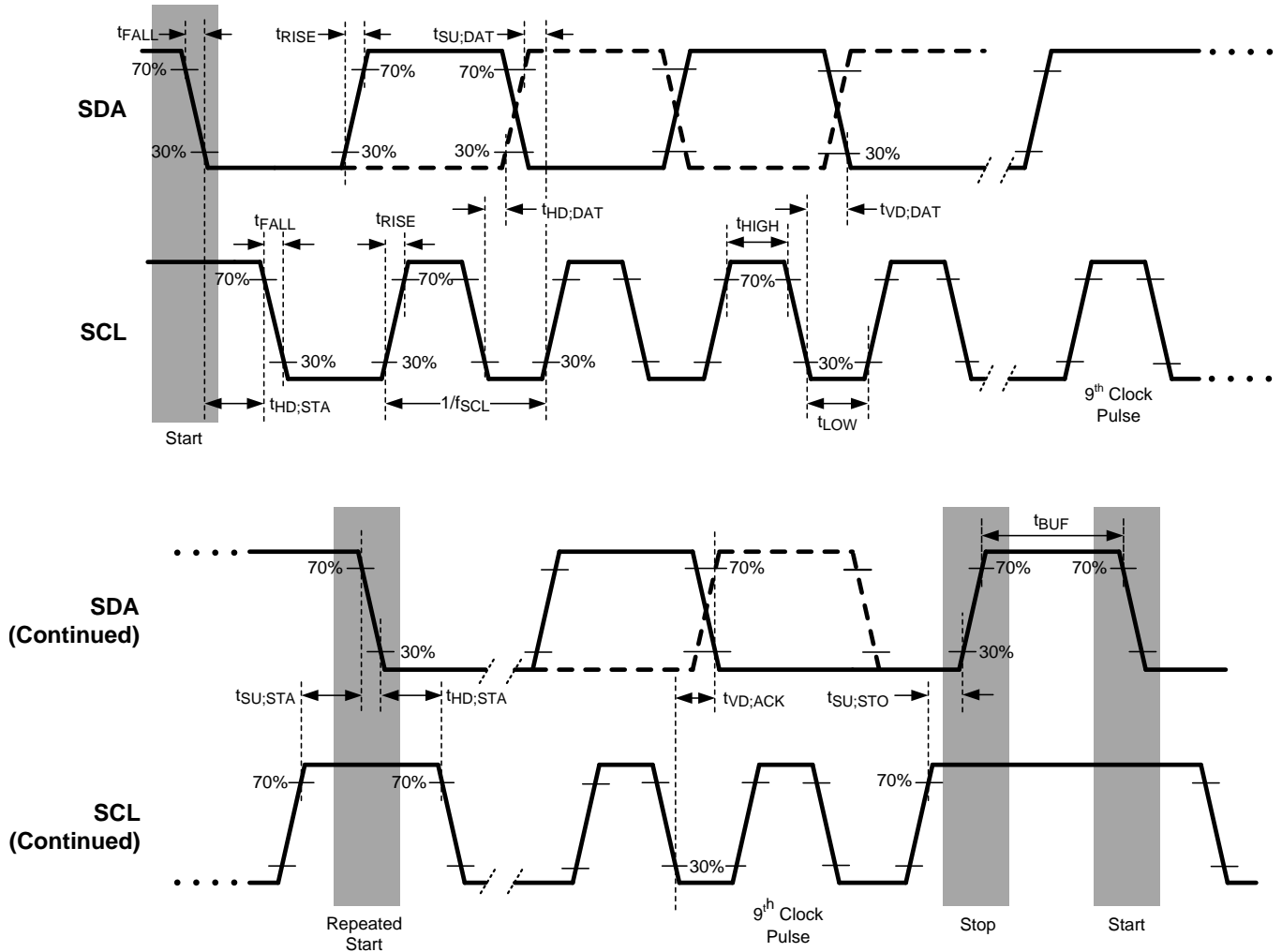

Figure 36. I<sup>2</sup>C-Compatible Timing

**I<sup>2</sup>C-COMPATIBLE CHIP ADDRESS**

The 7 bit I<sup>2</sup>C-compatible device address for the LM3561 is 1010011 (53). After the START condition, the I<sup>2</sup>C master sends the 7-bit address followed by an eighth bit, read or write (R/W). R/W = 0 indicates a WRITE (0xA6) and R/W = '1' indicates a READ (0xA7). The second byte following the device address selects the register address to which the data will be written. The third byte contains the data for the selected register.

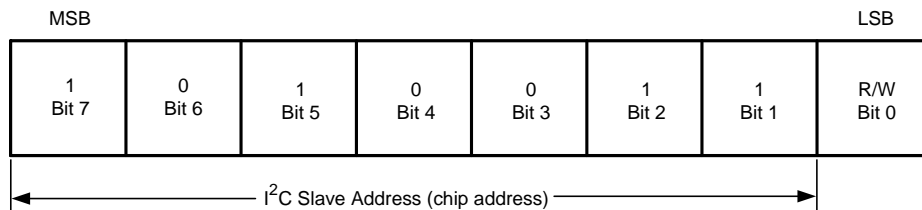

Figure 37. Device Address

## TRANSFERRING DATA

Every byte on the SDA line must be eight bits long with the most significant bit (MSB) transferred first. Each byte of data must be followed by an acknowledge bit (ACK). The acknowledge related clock pulse (9th clock pulse) is generated by the master. The master releases SDA (HIGH) during the 9th clock pulse (write mode). The LM3561 pulls down SDA during the 9th clock pulse, signifying an acknowledge. An acknowledge is generated after each byte has been received.

## Register Descriptions

**Table 3. LM3561 Internal Registers**

Register Name	Internal Hex Address	Power On or Reset Value
Enable Register	0x10	0xF8
Indicator Brightness Register	0x12	0xF8
GPIO Register	0x20	0x80
VIN Monitor Register	0x80	0xF8
Torch Brightness Register	0xA0	0xFA
Flash Brightness Register	0xB0	0xFD
Flash Duration Register	0xC0	0xEF
Flags Register	0xD0	0x00
Configuration Register 1	0xE0	0x6A
Configuration Register 2	0xF0	0xF0

### ENABLE REGISTER (ADDRESS 0x10)

The Enable Register contains the enable bits that turn on the device in Indicate Mode, Torch Mode, or Flash Mode (bits[1:0]). These bits are always reset at the end of a flash pulse. Bit [2] sets the STROBE level or edge control.

**Table 4. Enable Register Bit Settings**

Bits[7:3] Not Used	Bit 2 (Strobe Level or Edge, STR bit)	Bits [1:0] Enable Bits
N/A	0 = STROBE Input set for Level. Flash current turns on when STROBE input is high and turns off when STROBE either goes low or the Timeout Duration expires ( <b>default</b> ) 1 = STROBE Input set for edge triggered. Flash current turns on when STROBE sees a rising edge. Flash pulse turns off when timeout duration expires	Enable Bits 00 = Shutdown ( <b>default</b> ) 01 = Indicator Mode 10 = Torch Mode 11 = Flash Mode (bits reset at timeout)

### INDICATOR BRIGHTNESS REGISTER (ADDRESS 0x12)

The Indicator Register contains the bits to set the indicator current level in indicate mode.

**Table 5. Indicator Brightness Register Bit Settings**

Bits [7:3] Not Used	Bits [2:0] Indicate Current Settings
N/A	<b>000 = 2.25mA (default)</b> 001 = 4.5mA 010 = 6.75mA 011 = 9mA 100 = 11.25mA 101 = 13.5mA 110 = 15.75mA 111 = 18mA

### GPIO REGISTER (ADDRESS 0x20)

The GPIO register contains the control bits which change the state of the TX1/TORCH/GPIO1 pin and the TX2/GPIO2 pin to general purpose I/O's (GPIO's).

**Table 6. GPIO Register Bit Settings**

Bit 7 Not Used	Bit 6 TX2/GPIO2/INT Interrupt Output	Bit 5 TX2/GPIO2 data	Bit 4 TX2/GPIO2 data direction	Bit 3 TX2/GPIO2 Control	Bit 2 TX1/GPIO1 data	Bit 1 TX1/GPIO1 data direction	Bit 0 TX1/GPIO1 Control
N/A	0 = INT mode is disabled ( <b>default</b> ) 1 = When TX2/GPIO2 is configured as a GPIO output TX2/GPIO2/INT is set for INT mode and will pull low when either the LED Thermal Fault Flag is set or the VIN Monitor Flag is set	This bit is the read or write data for TX2/GPIO2 in GPIO mode ( <b>default is 0</b> )	0 = TX2/GPIO2 is a GPIO Input ( <b>default</b> ) 1 = TX2/GPIO2 is a GPIO Output	0 = TX2/GPIO2 is a flash interrupt input ( <b>default</b> ) 1 = TX2/GPIO2 is configured as a GPIO	This bit is the read or write data for TX1/GPIO1 in GPIO mode ( <b>default is 0</b> )	0 = TX1/GPIO1 is a GPIO input ( <b>default</b> ) 1 = TX1/GPIO1 is a GPIO output	0 = TX1/GPIO1 is configured as flash interrupt input ( <b>default</b> ) 1 = TX1/GPIO1 is configured as a GPIO

### VIN MONITOR REGISTER (ADDRESS 0x80)

The VIN Monitor Register controls the on/off state of the VIN Monitor comparator as well as selects the 4 programmable thresholds.

**Table 7. VIN Monitor Register Bit Settings**

Bits [7:3] Not Used	Bits [2:1] VIN Monitor Threshold Settings	Bit 0 VIN Monitor Enable
N/A	00 = 2.9V threshold ( $V_{IN}$ falling) <b>Default</b> 01 = 3.0V threshold ( $V_{IN}$ falling) 10 = 3.1V threshold ( $V_{IN}$ falling) 11 = 3.2V threshold ( $V_{IN}$ falling)	0 = VIN Monitor Comparator is disabled ( <b>default</b> ) 1 = VIN Monitor Comparator is enabled.

### TORCH BRIGHTNESS REGISTER (0xA0)

The Torch Brightness Register contains the bits to program the LED current in Torch Mode.

**Table 8. Torch Brightness Register Bit Settings**

Bits [7:3] Not Used	Bits [2:0] Torch Current Settings
N/A	000 = 18mA 001 = 36.8mA <b>010 = 55.6mA (default)</b> 011 = 74.4mA 100 = 93.2mA 101 = 112mA 110 = 130.8mA 111 = 149.6mA

**FLASH BRIGHTNESS REGISTER (ADDRESS 0XB0)**

The Flash Brightness Register contains the bits to program the LED current in flash mode.

**Table 9. Flash Brightness Register Bit Settings**

Bits [7:4] Not Used	Bits [3:0] Flash Current Settings
N/A	0000 = 36mA 0001 = 73.6mA 0010 = 111.2mA 0011 = 148.8mA 0100 = 186.4mA 0101 = 224mA 0110 = 261.6mA 0111 = 299.2mA 1000 = 336.8mA 1001 = 374.4mA 1010 = 412mA 1011 = 449.6mA 1100 = 487.2mA <b>1101 = 524.8mA Default</b> 1110 = 562.4mA 1111 = 600mA

**FLASH DURATION REGISTER (ADDRESS 0XC0)**

Bits [4:0] of the Flash Duration Register set the Flash timeout duration. Bit [5] sets the switch current limit.

**Table 10. Flash Timeout Duration Register Bit Settings**

Bit [7:6] Not Used	Bit 5 Current Limit Select	Bits [4:0] Flash Timeout Duration Settings
N/A	0 = 1A Peak Current Limit 1 = 1.5A Peak Current Limit ( <b>default</b> )	00000 = 32ms timeout 00001 = 64ms timeout 00010 = 96ms timeout 00011 = 128ms timeout 00100 = 160ms timeout 00101 = 192ms timeout 00110 = 224ms timeout 00111 = 256ms timeout 01000 = 288ms timeout 01001 = 320ms timeout 01010 = 352ms timeout 01011 = 384ms timeout 01100 = 416ms timeout 01101 = 448ms timeout 01110 = 480ms timeout <b>01111 = 512ms timeout (default)</b> 10000 = 544ms timeout 10001 = 576ms timeout 10010 = 608ms timeout 10011 = 640ms timeout 10100 = 672ms timeout 10101 = 704ms timeout 10110 = 736ms timeout 10111 = 768ms timeout 11000 = 800ms timeout 11001 = 832ms timeout 11010 = 864ms timeout 11011 = 896ms timeout 11100 = 928ms timeout 11101 = 960ms timeout 11110 = 992ms timeout 11111 = 1024ms timeout

## FLAGS REGISTER (ADDRESS 0XD0)

The Flags Register holds the status of the flag bits indicating LED Failure, Over-Temperature, the Flash Timeout expiring, VIN Monitor Fault, LED over temperature (NTC), and a TX1 or TX2 interrupt.

**Table 11. Flags Register Bit Settings**

Bit 7 VIN Monitor Flag	Bit 6 Not Used	Bit 5 LED Thermal Fault (NTC)	Bit 4 TX2 Interrupt	Bit 3 TX1 Interrupt	Bit 2 Led Fault (LEDF)	Bit 1 Thermal Shutdown (TSD)	Bit 0 Flash Timeout (TO)
0 = No Fault at VIN ( <b>default</b> ) 1 = Input Voltage Monitor is enabled and VIN has fallen below ( $V_{IN\_TH}$ )	N/A	0 = LEDI/NTC pin is above $V_{TRIP}$ ( <b>default</b> ) 1 = LEDI/NTC has fallen below $V_{TRIP}$ (NTC mode only)	0 = TX2 has not changed state ( <b>default</b> ) 1 = TX2 has changed state (TX2 mode only)	0 = TX1/TORCH has not changed state ( <b>default</b> ) 1 = TX1/TORCH pin has changed state (TX1 mode only)	0 = Proper LED Operation ( <b>default</b> ) 1 = LED Failed (Open or Short)	0 = Die Temperature below Thermal Shutdown Limit ( <b>default</b> ) 1 = Die Temperature has crossed the Thermal Shutdown Threshold of +150°C	0 = Flash timeout did not expire ( <b>default</b> ) 1 = Flash timeout Expired

## CONFIGURATION REGISTER 1 (ADDRESS 0XE0)

Configuration Register 1 contains the STROBE enable/disable bit, the STROBE polarity bit, the NTC enable bit, the polarity selection for TX1 and TX2 flash interrupts, and the hardware torch mode enable for TX1/TORCH.

**Table 12. Configuration Register 1 Bit Settings**

Bit 7 Hardware Torch Mode Enable	Bit 6 TX2 Polarity	Bit 5 TX1 Polarity	Bit 4 NTC Mode Enable	Bit 3 STROBE Polarity	Bit 2 STROBE Input Enable	Bit 1 Not Used	Bit 0 Not Used
0 = TX1/TORCH is a TX1 flash interrupt input ( <b>default</b> ) 1 = TX1/TORCH pin is a hardware TORCH enable. This bit is reset to 0 after a flash event.	0 = TX2 is set for active low polarity 1 = TX2 is set for active high polarity ( <b>default</b> )	0 = TX1 is set for active low polarity 1 = TX1 is set for active high polarity ( <b>default</b> )	0 = LEDI/NTC is a Indicator Current Source Output ( <b>default</b> ) 1 = LEDI/NTC is a Comparator Input for LED Temperature Sensing	0 = STROBE set for active low polarity 1 = STROBE set for active high polarity ( <b>default</b> )	0 = STROBE Input Disabled ( <b>default</b> ) 1 = STROBE Input Enabled	N/A	N/A

**CONFIGURATION REGISTER 2 (ADDRESS 0XF0)**

Configuration Register 2 contains the TX2 shutdown bit, the NTC shutdown bit, the Alternate External Torch Enable bit, and the VIN Monitor Shutdown bit.

**Table 13. Configuration Register 2 Bit Settings**

Bits [7:4] Not Used	Bit 3 V <sub>IN</sub> Monitor Shutdown	Bit 2 AET mode	Bit 1 NTC Shutdown	Bit 0 TX2 Shutdown
N/A	0 = If IN drops below V <sub>IN_TH</sub> and the VIN Monitor feature is enabled, the LEDs are forced into Torch mode ( <b>default</b> ) 1 = If IN drops below V <sub>IN_TH</sub> and the VIN Monitor feature is enabled, the LEDs turn off	0 = Normal operation for TX1/TORCH high before STROBE (TX1 mode only) <b>default</b> 1 = Alternate External Torch Mode. TX1/TORCH high before STROBE forces Torch mode with no timeout (TX1 mode only)	0 = LEDI/NTC pin going below V <sub>TRIP</sub> forces the LEDs into Torch mode (NTC mode only) <b>default</b> 1 = LEDI/NTC pin going below V <sub>TRIP</sub> forces the LEDs into shutdown (NTC mode only)	0 = TX2 interrupt event forces the flash LED into Torch mode (TX2 mode only) <b>default</b> 1 = TX2 interrupt event forces the flash LED into shutdown (TX2 mode only)

## APPLICATIONS INFORMATION

### OUTPUT CAPACITOR SELECTION

The LM3561 is designed to operate with at least a 10µF ceramic output capacitor. When the boost converter is running the output capacitor supplies the load current during the boost converter's on-time. When the NMOS switch turns off the inductor energy is discharged through the internal PMOS switch supplying power to the load and restoring charge to the output capacitor. This causes a sag in the output voltage during the on-time and a rise in the output voltage during the off-time. The output capacitor is therefore chosen to limit the output ripple to an acceptable level depending on load current and input/output voltage differentials and also to ensure the converter remains stable.

For proper LED operation the output capacitor must be at least a 10µF ceramic. Larger capacitors such as 22µF can be used if lower output voltage ripple is desired. To estimate the output voltage ripple considering the ripple due to capacitor discharge ( $\Delta V_Q$ ) and the ripple due to the capacitors ESR ( $\Delta V_{ESR}$ ) use the following equations:

For continuous conduction mode, the output voltage ripple due to the capacitor discharge is:

$$\Delta V_Q = \frac{I_{LED} \times (V_{OUT} - V_{IN})}{f_{SW} \times V_{OUT} \times C_{OUT}} \quad (1)$$

The output voltage ripple due to the output capacitors ESR is found by:

$$\Delta V_{ESR} = R_{ESR} \times \left( \frac{I_{LED} \times V_{OUT}}{V_{IN}} \right) + \Delta I_L$$

where

$$\Delta I_L = \frac{V_{IN} \times (V_{OUT} - V_{IN})}{2 \times f_{SW} \times L \times V_{OUT}} \quad (2)$$

In ceramic capacitors the ESR is very low so assume that 80% of the output voltage ripple is due to capacitor discharge and 20% from ESR. [Table 14](#) lists different manufacturers for various output capacitors and their case sizes suitable for use with the LM3561.

### INPUT CAPACITOR SELECTION

Choosing the correct size and type of input capacitor helps minimize the voltage ripple caused by the switching of the LM3561's boost converter and reduces noise on the device's input terminal that can feed through and disrupt internal analog signals. In the Typical Application Circuit a 10µF ceramic input capacitor works well. It is important to place the input capacitor as close as possible to the LM3561's input (IN) terminals. This reduces the series resistance and inductance that can inject noise into the device due to the input switching currents. [Table 14](#) lists various input capacitors recommended for use with the LM3561.

**Table 14. Recommended Input/Output Capacitors (X5R Dielectric)**

Manufacturer	Part Number	Value	Case Size	Voltage Rating
TDK Corporation	C1608JB0J106M	10µF	0603(1.6mm×0.8mm×0.8mm)	6.3V
TDK Corporation	C2012JB1A106M	10µF	0805(2mm×1.25mm×1.25mm)	10V
TDK Corporation	C2012JB0J226M	22µF	0805(2mm×1.25mm×1.25mm)	6.3V
Murata	GRM21BR61A106KE19	10µF	0805(2mm×1.25mm×1.25mm)	10V
Murata	GRM21BR60J226ME39L	22µF	0805(2mm×1.25mm×1.25mm)	6.3V

### INDUCTOR SELECTION

The LM3561 is designed to use a 1µH to 2.2µH inductor. [Table 15](#) lists various inductors that can work well with the LM3561. When the device is boosting ( $V_{OUT} > V_{IN}$ ) the inductor will typically be the biggest area of efficiency loss in the circuit. Therefore, choosing an inductor with the lowest possible series resistance is important. Additionally, the saturation rating of the inductor should be greater than the maximum operating peak current of the LM3561. This prevents excess efficiency loss that can occur with inductors that operate in saturation. For proper inductor operation and circuit performance ensure that the inductor saturation and the peak current limit setting of the LM3561 is greater than  $I_{PEAK}$ . This can be calculated by:

$$I_{PEAK} = \frac{I_{LOAD}}{\eta} \times \frac{V_{OUT}}{V_{IN}} + \Delta I_L \quad \text{where} \quad \Delta I_L = \frac{V_{IN} \times (V_{OUT} - V_{IN})}{2 \times f_{SW} \times L \times V_{OUT}} \quad (3)$$

$f_{SW} = 2\text{MHz}$ , and  $\eta$  can be found in the Typical Performance Characteristics plots.

**Table 15. Recommended Inductors**

Manufacturer	L	Part Number	Dimensions (LxWxH)	R <sub>DC</sub>	I <sub>SAT</sub>
Coilcraft	1μH	XPL2010-102ML	2mmx1.9mmx1mm	81mΩ	1.6A
TDK	1μH	VLS252012T-1R0N	2mmx2.5mmx1.2mm	73mΩ	2.7A
TDK	1μH	VLS2010-1R0N	2mm x 2mm x 1mm	90mΩ	1.65A
TDK	1μH	VLS2012ET-1R0N	2mm x 2mm x 1.2mm	71mΩ	1.65A
TDK	1μH	VLS20160ET-1R0N	2mm x 1.6mm x 0.95mm	100mΩ	1.5A
TDK	1μH	VLS252010ET-1R0N	2.5mm x 2mm x 1mm	70mΩ	1.9A

### NTC THERMISTOR SELECTION

Programming bit [4] of Configuration Register 1 with a (1) selects Thermal Comparator mode, making the LED/NTC pin a comparator input for flash LED thermal sensing. The thermal sensing circuit consists of a negative temperature coefficient (NTC) thermistor and a series resistor which forms a resistive divider (see Figure 38).

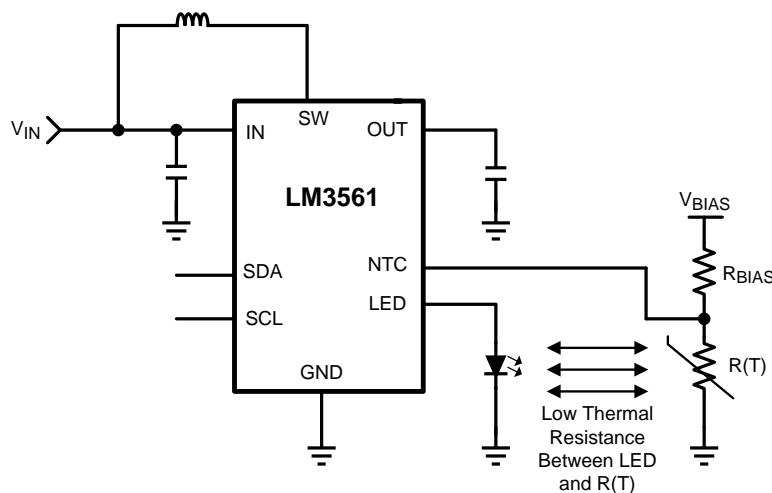

**Figure 38. NTC Circuit**

The NTC thermistor senses the LEDs temperature via conducting the LEDs heat into the NTC thermistor. Heat conduction is improved with a galvanic connection at GND (LED cathode and NTC thermistor GND terminal) and by placing the thermistor in very close proximity to the flash LED.

NTC thermistors have a temperature to resistance relationship of:

$$R(T) = R_{25^{\circ}\text{C}} \times e^{\left[ \beta \left( \frac{1}{T^{\circ}\text{C} + 273} - \frac{1}{298} \right) \right]} \quad (4)$$

where  $\beta$  is given in the thermistor datasheet and  $R_{25^{\circ}\text{C}}$  is the thermistor's value at  $+25^{\circ}\text{C}$ .  $R_{BIAS}$  is chosen so that it is equal to:

$$R_{BIAS} = \frac{R_{T(TRIP)} (V_{BIAS} - V_{TRIP})}{V_{TRIP}} \quad (5)$$

where  $R(T)_{TRIP}$  is the thermistor's value at the temperature trip point,  $V_{BIAS}$  is the bias voltage for the thermistor circuit, and  $V_{TRIP} = 1V$  (typical). Choosing  $R_{BIAS}$  here gives a more linear response around the temperature trip voltage. For example with  $V_{BIAS} = 1.8V$  and a thermistor whose nominal value at  $+25^{\circ}C$  is  $10k\Omega$  and a  $\beta = 3380K$ , the trip point is chosen to be  $+93^{\circ}C$ . The value of  $R(T)$  at  $93^{\circ}C$  is:

$$R(T) = 10\text{ k}\Omega \times e^{\left[\beta\left(\frac{1}{93+273} - \frac{1}{298}\right)\right]} = 1.215\text{ k}\Omega$$

$$R_{BIAS} \text{ is then: } \frac{1.215\text{ k}\Omega \times (1.8V - 1V)}{1V} = 972\Omega$$

(6)

Figure 39 shows the linearity of the thermistor resistive divider of the previous example.

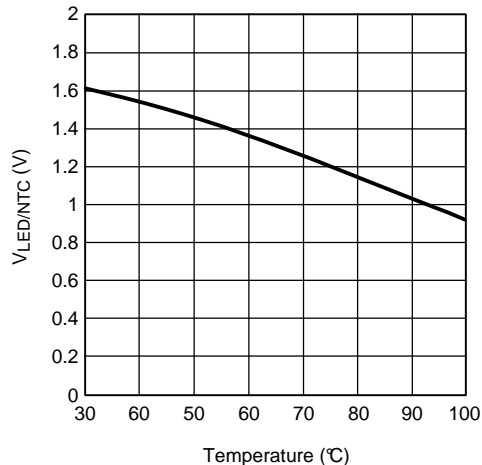

**Figure 39. Thermistor Resistive Divider Response vs Temperature**  
**VLED/NTC vs Temp ( $V_{BIAS} = 1.8V$ , THERMISTOR =  $10k\Omega$  at  $+25^{\circ}C$ ,  $\beta = 3380$ ,  $R_{BIAS} = 972\Omega$ )**

Another useful equation for the thermistor resistive divider is developed by combining the equations for  $R_{BIAS}$ , and  $R(T)$  and solving for temperature. This gives the following relationship.

$$T(^{\circ}C) = \frac{\beta \times 298^{\circ}C}{298^{\circ}C \times \ln\left[\frac{V_{TRIP} \times R_{BIAS}}{(V_{BIAS} - V_{TRIP}) \times R_{25^{\circ}C}}\right] + \beta} - 273^{\circ}C$$

(7)

Using a spreadsheet such as Excel, different curves for the temperature trip point  $T(^{\circ}C)$  can be created vs  $R_{BIAS}$ , Beta, or  $V_{BIAS}$  in order to help better choose the thermal components for practical values of thermistors, series resistors ( $R_3$ ), or reference voltages  $V_{BIAS}$ .

## NTC THERMISTOR PLACEMENT

The termination of the thermistor must be done directly to the cathode of the Flash LED in order to adequately couple the heat from the LED into the thermistor. Consequentially, the noisy environment generated from the switching of the LM3561's boost converter can introduce noise from GND into the thermistor sensing input. To filter out this noise it is necessary to place a  $0.1\mu F$  or larger ceramic capacitor close to the LED/NTC pin. The filter capacitor's return must also connect with a low-impedance trace, as close as possible to the GND pin of the LM3561.

## Layout Recommendations

The high frequency and relatively large switching currents of the LM3561 make the choice of layout important. The following steps should be used as a reference to ensure the device is stable and maintains proper voltage and current regulation across its intended operating voltage and current range.

1. Place  $C_{IN}$  on the top layer (same layer as the LM3561) and as close to the device as possible. The input capacitor conducts the driver currents during the low-side MOSFET turn-on and turn-off and can see current spikes over 500mA in amplitude. Connecting the input capacitor through short wide traces on both the IN and GND terminals will reduce the inductive voltage spikes that occur during switching and which can corrupt the  $V_{IN}$  line.
2. Place  $C_{OUT}$  on the top layer (same layer as the LM3561) and as close as possible to the OUT and GND terminal. The returns for both  $C_{IN}$  and  $C_{OUT}$  should come together at one point, and as close to the GND pin as possible. Connecting  $C_{OUT}$  through short wide traces will reduce the series inductance on the OUT and GND terminals that can corrupt the  $V_{OUT}$  and GND line and cause excessive noise in the device and surrounding circuitry.
3. Connect the inductor on the top layer close to the SW pin. There should be a low-impedance connection from the inductor to SW due to the large DC inductor current, and at the same time the area occupied by the SW node should be small so as to reduce the capacitive coupling of the fast  $dV/dt$  present at SW that can couple into nearby traces.
4. Avoid routing logic traces near the SW node so as to avoid any capacitively coupled voltages from SW onto any high impedance logic lines such as TX1/TORCH/GPIO1, TX2/GPIO2/INT, HWEN, LEDI/NTC (NTC mode), SDA, and SCL. A good approach is to insert an inner layer GND plane underneath the SW node and between any nearby routed traces. This creates a shield from the electric field generated at SW.
5. Terminate the Flash LED cathode directly to the GND pin of the LM3561. If possible, route the LED return with a dedicated path so as to keep the high amplitude LED current out of the GND plane. For a Flash LED that is routed relatively far away from the LM3561, a good approach is to sandwich the forward and return current paths over the top of each other on two adjacent layers. This will help in reducing the inductance of the LED current paths.
6. The NTC Thermistor is intended to have its return path connected to the LED's cathode. This allows the thermistor resistive divider voltage ( $V_{NTC}$ ) to trip the comparators threshold as  $V_{NTC}$  is falling. Additionally, the thermistor to LED cathode junction can have low thermal resistivity since both the LED and the thermistor are electrically connected at GND. The draw back is that the thermistor's return will see the switching currents from the LM3561's boost converter. Because of this, it is necessary to have a filter capacitor at the NTC pin which terminates close to the GND of the LM3561 and which can conduct the switched currents to GND.

### REVISION HISTORY

Changes from Revision B (April 2013) to Revision C	Page
• Changed layout of National Data Sheet to TI format .....	<a href="#">31</a>

**PACKAGING INFORMATION**

Orderable Device	Status (1)	Package Type	Package Drawing	Pins	Package Qty	Eco Plan (2)	Lead/Ball Finish (6)	MSL Peak Temp (3)	Op Temp (°C)	Device Marking (4/5)	Samples
LM3561TME/NOPB	ACTIVE	DSBGA	YFQ	12	250	Green (RoHS & no Sb/Br)	SNAGCU	Level-1-260C-UNLIM	-40 to 85	DV	<a href="#">Samples</a>
LM3561TMX/NOPB	ACTIVE	DSBGA	YFQ	12	3000	Green (RoHS & no Sb/Br)	SNAGCU	Level-1-260C-UNLIM	-40 to 85	DV	<a href="#">Samples</a>

(1) The marketing status values are defined as follows:

**ACTIVE:** Product device recommended for new designs.

**LIFEBUY:** TI has announced that the device will be discontinued, and a lifetime-buy period is in effect.

**NRND:** Not recommended for new designs. Device is in production to support existing customers, but TI does not recommend using this part in a new design.

**PREVIEW:** Device has been announced but is not in production. Samples may or may not be available.

**OBSOLETE:** TI has discontinued the production of the device.

(2) Eco Plan - The planned eco-friendly classification: Pb-Free (RoHS), Pb-Free (RoHS Exempt), or Green (RoHS & no Sb/Br) - please check <http://www.ti.com/productcontent> for the latest availability information and additional product content details.

**TBD:** The Pb-Free/Green conversion plan has not been defined.

**Pb-Free (RoHS):** TI's terms "Lead-Free" or "Pb-Free" mean semiconductor products that are compatible with the current RoHS requirements for all 6 substances, including the requirement that lead not exceed 0.1% by weight in homogeneous materials. Where designed to be soldered at high temperatures, TI Pb-Free products are suitable for use in specified lead-free processes.

**Pb-Free (RoHS Exempt):** This component has a RoHS exemption for either 1) lead-based flip-chip solder bumps used between the die and package, or 2) lead-based die adhesive used between the die and leadframe. The component is otherwise considered Pb-Free (RoHS compatible) as defined above.

**Green (RoHS & no Sb/Br):** TI defines "Green" to mean Pb-Free (RoHS compatible), and free of Bromine (Br) and Antimony (Sb) based flame retardants (Br or Sb do not exceed 0.1% by weight in homogeneous material)

(3) MSL, Peak Temp. - The Moisture Sensitivity Level rating according to the JEDEC industry standard classifications, and peak solder temperature.

(4) There may be additional marking, which relates to the logo, the lot trace code information, or the environmental category on the device.

(5) Multiple Device Markings will be inside parentheses. Only one Device Marking contained in parentheses and separated by a "~" will appear on a device. If a line is indented then it is a continuation of the previous line and the two combined represent the entire Device Marking for that device.

(6) Lead/Ball Finish - Orderable Devices may have multiple material finish options. Finish options are separated by a vertical ruled line. Lead/Ball Finish values may wrap to two lines if the finish value exceeds the maximum column width.

**Important Information and Disclaimer:** The information provided on this page represents TI's knowledge and belief as of the date that it is provided. TI bases its knowledge and belief on information provided by third parties, and makes no representation or warranty as to the accuracy of such information. Efforts are underway to better integrate information from third parties. TI has taken and continues to take reasonable steps to provide representative and accurate information but may not have conducted destructive testing or chemical analysis on incoming materials and chemicals. TI and TI suppliers consider certain information to be proprietary, and thus CAS numbers and other limited information may not be available for release.

In no event shall TI's liability arising out of such information exceed the total purchase price of the TI part(s) at issue in this document sold by TI to Customer on an annual basis.

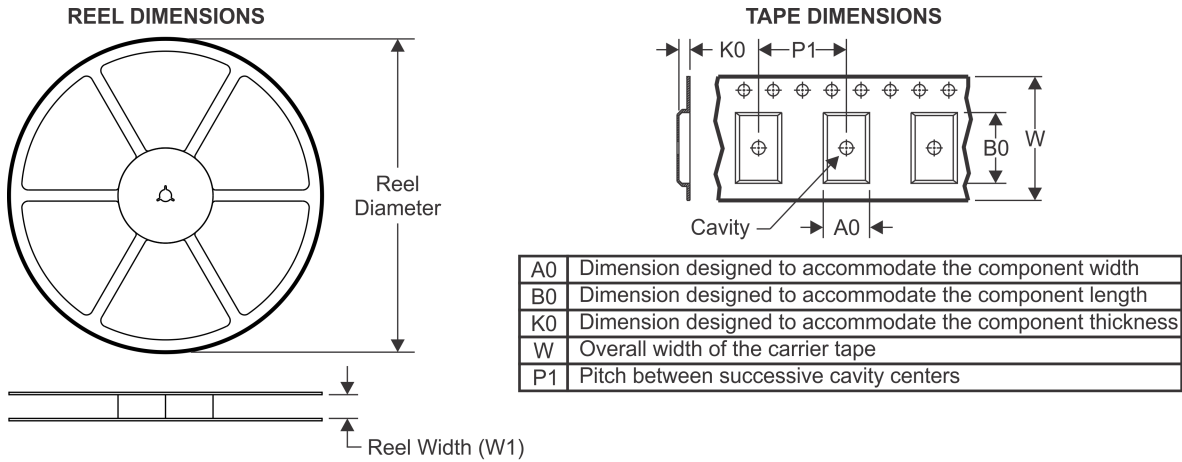
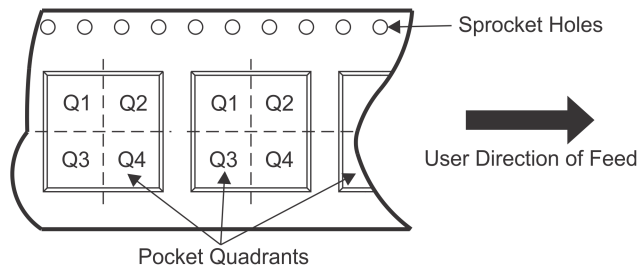
**TAPE AND REEL INFORMATION**

**QUADRANT ASSIGNMENTS FOR PIN 1 ORIENTATION IN TAPE**

\*All dimensions are nominal

Device	Package Type	Package Drawing	Pins	SPQ	Reel Diameter (mm)	Reel Width W1 (mm)	A0 (mm)	B0 (mm)	K0 (mm)	P1 (mm)	W (mm)	Pin1 Quadrant
LM3561TME/NOPB	DSBGA	YFQ	12	250	178.0	8.4	1.35	1.75	0.76	4.0	8.0	Q1
LM3561TMX/NOPB	DSBGA	YFQ	12	3000	178.0	8.4	1.35	1.75	0.76	4.0	8.0	Q1

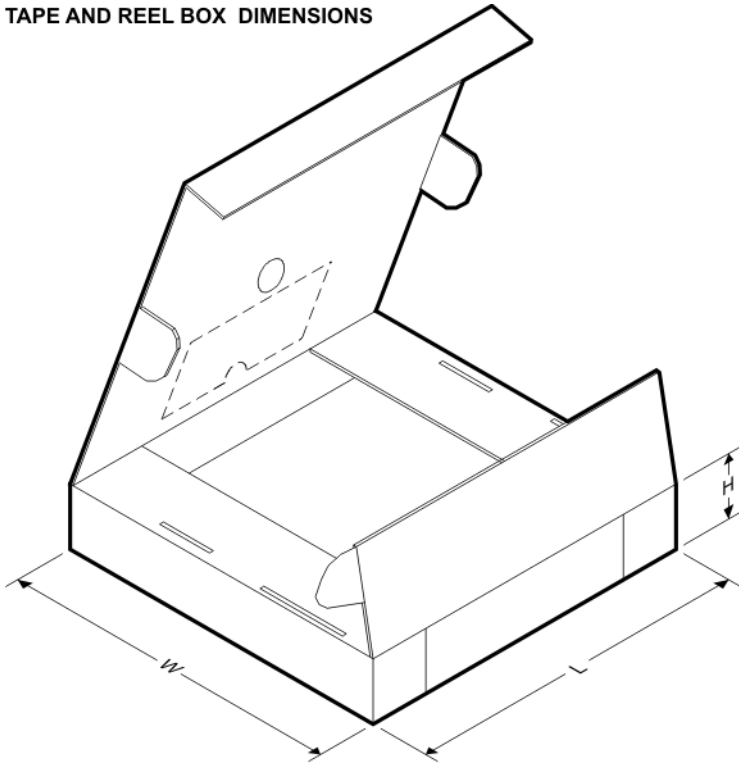
TAPE AND REEL BOX DIMENSIONS



\*All dimensions are nominal

Device	Package Type	Package Drawing	Pins	SPQ	Length (mm)	Width (mm)	Height (mm)
LM3561TME/NOPB	DSBGA	YFQ	12	250	210.0	185.0	35.0
LM3561TMX/NOPB	DSBGA	YFQ	12	3000	210.0	185.0	35.0

YFQ0012

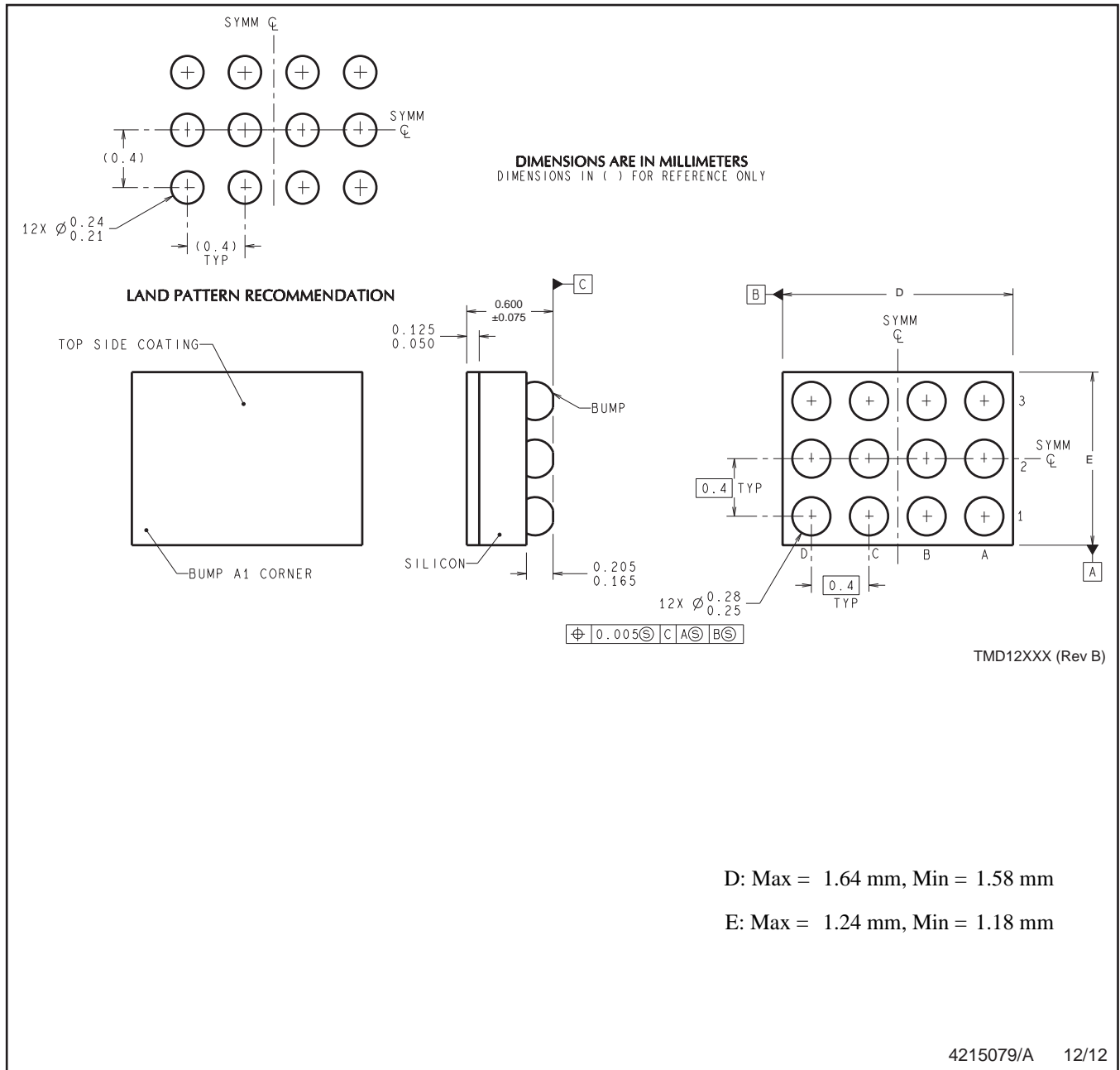

4215079/A 12/12

NOTES: A. All linear dimensions are in millimeters. Dimensioning and tolerancing per ASME Y14.5M-1994.  
B. This drawing is subject to change without notice.

## IMPORTANT NOTICE AND DISCLAIMER

TI PROVIDES TECHNICAL AND RELIABILITY DATA (INCLUDING DATASHEETS), DESIGN RESOURCES (INCLUDING REFERENCE DESIGNS), APPLICATION OR OTHER DESIGN ADVICE, WEB TOOLS, SAFETY INFORMATION, AND OTHER RESOURCES "AS IS" AND WITH ALL FAULTS, AND DISCLAIMS ALL WARRANTIES, EXPRESS AND IMPLIED, INCLUDING WITHOUT LIMITATION ANY IMPLIED WARRANTIES OF MERCHANTABILITY, FITNESS FOR A PARTICULAR PURPOSE OR NON-INFRINGEMENT OF THIRD PARTY INTELLECTUAL PROPERTY RIGHTS.

These resources are intended for skilled developers designing with TI products. You are solely responsible for (1) selecting the appropriate TI products for your application, (2) designing, validating and testing your application, and (3) ensuring your application meets applicable standards, and any other safety, security, or other requirements. These resources are subject to change without notice. TI grants you permission to use these resources only for development of an application that uses the TI products described in the resource. Other reproduction and display of these resources is prohibited. No license is granted to any other TI intellectual property right or to any third party intellectual property right. TI disclaims responsibility for, and you will fully indemnify TI and its representatives against, any claims, damages, costs, losses, and liabilities arising out of your use of these resources.

TI's products are provided subject to TI's Terms of Sale ([www.ti.com/legal/termsofsale.html](http://www.ti.com/legal/termsofsale.html)) or other applicable terms available either on [ti.com](http://ti.com) or provided in conjunction with such TI products. TI's provision of these resources does not expand or otherwise alter TI's applicable warranties or warranty disclaimers for TI products.

Mailing Address: Texas Instruments, Post Office Box 655303, Dallas, Texas 75265  
Copyright © 2018, Texas Instruments Incorporated

## Looking for pricing, stock, or lifecycle information?

Click below to explore more details on WIN SOURCE:

 [View LM3561TME/NOPB on WIN SOURCE](#)

 [Texas Instruments](#) Information

## Optimize Your Supply Chain with WIN SOURCE Solutions

-  Global Sourcing Solution
-  Obsolete Management
-  Cost Control Management
-  Shortage Management
-  Alternative Solution
-  Excess Inventory Management