



**THE DATASHEET OF
LM3466MR/NOPB**



Multi-String LED Current Balancer for Use with Constant-Current Power Supplies

Check for Samples: [LM3466](#)

FEATURES

- **Easy to Design for Lighting Systems Consisting of Multiple LED Strings (Supports Modular Design)**
- **Automatically Balances the Current of Every Active LED String, even the Forward Voltage of Each String is Different**
- **Easy to Pre-Set and Fine-Tune Current Ratio Among LED Strings (e.g., color temperature adjustment or CRI Enhancement)**
- **$\pm 1\%$ Current Accuracy at Room Temperature and $\pm 1.5\%$ Over Temperature**
- **Maintains Constant Output Power if Some Strings Open (inactive) by Automatically Balancing the Current of Remaining Active LED Strings**
- **Works with a Constant Current Power Supply (ac/dc or dc/dc), and no Communication to/from the Constant Current Power Supply is Required**
- **Operates with Minimum Voltage Overhead to Maximize Power Efficiency**
- **Wide Input Voltage Range from 6 V to 70 V**
- **Fault Status Output**
- **Thermal Shutdown**
- **Integrated 70-V, 1.5-A MOSFET with 2.06 A Current Limit**
- **Maximum 70-V per LED String, 20 LEDs**
- **Linear Circuitry Does Not Deteriorate EMI**
- **DDA-8 Exposed Thermal Pad and TO220-7 Packages**

APPLICATIONS

- **Street Lamps**
- **Solid State Lighting Systems**

DESCRIPTION

The LM3466 integrates a linear LED driver for lighting systems which consist of multiple LED strings powered by a constant current power supply. It balances the current provided by the supply in a pre-set ratio for each active LED string, where an active string is a fully turned on LED string, regardless of the number of strings connected to the supply or the forward voltage of each LED string. If any LED string opens during operation, the LM3466 automatically balances the supply current through all of the remaining active LED strings. As a result, the overall brightness of the lighting system is maintained even if some LED strings open during operation.

The LM3466 lighting system is simple to design owing to a proprietary control scheme. To minimize the component count, the LM3466 integrates a 70-V, 1.5-A, N-channel power MOSFET with a current limit of 2.06 A. To add one more LED string to the system, only a single resistor, a capacitor, and a LM3466 are required. Other supervisory features of the LM3466 include under-voltage lock-out, fault reporting, thermal latch off, and thermal shutdown protection.

The LM3466 consists of only linear circuitry so that the EMI of the application circuit is not deteriorated. The LM3466 lighting system is EMI friendly if the constant current power supply used is complied to EMI standards. The LM3466 is available in the DDA-8 exposed thermal pad and TO220-7 packages.

SIMPLIFIED APPLICATION

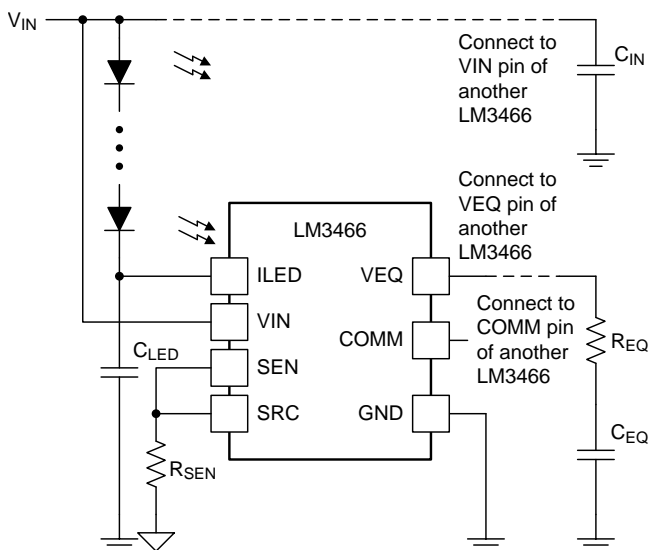

Please be aware that an important notice concerning availability, standard warranty, and use in critical applications of Texas Instruments semiconductor products and disclaimers thereto appears at the end of this data sheet.

All trademarks are the property of their respective owners.



These devices have limited built-in ESD protection. The leads should be shorted together or the device placed in conductive foam during storage or handling to prevent electrostatic damage to the MOS gates.

ABSOLUTE MAXIMUM RATINGS ⁽¹⁾

If Military/Aerospace specified devices are required, contact the Texas Instruments Sales Office/ Distributors for availability and specifications.

	MIN	MAX	UNIT
V _{IN} , ILED to GND	–0.3	75	V
COMM to GND	–0.3	7	V
SEN, SRC, VEQ to GND	–0.3	5	V
ESD Rating ⁽²⁾ , Human Body Model	–2	2	kV
Storage Temperature Range	–65	150	°C
Junction Temperature (T _J)		150	°C

(1) Absolute Maximum Ratings are limits beyond which damage to the device may occur.

(2) The human body model is a 100-pF capacitor discharged through a 1.5-kΩ resistor into each pin.

RECOMMENDED OPERATING CONDITIONS ⁽¹⁾

	MIN	MAX	UNIT
Supply Voltage Range (V _{IN})	6	70	V
Junction Temperature Range (T _J)	–40	125	°C

(1) Recommended Operating conditions are those under which operation of the device is intended to be functional. For specifications and test conditions, see the Electrical Characteristics table.

THERMAL INFORMATION

THERMAL METRIC		SO PowerPAD	TO-220	UNITS
		DDA	NEC ⁽¹⁾	
		8 PINS	7 PINS	
θ _{JA}	Junction-to-ambient thermal resistance ⁽²⁾	50.7	32.2	°C/W
θ _{JCtop}	Junction-to-case (top) thermal resistance ⁽³⁾	56.1	36.4	
θ _{JB}	Junction-to-board thermal resistance ⁽⁴⁾	28.9	25.2	
ψ _{JT}	Junction-to-top characterization parameter ⁽⁵⁾	9.8	6.2	
ψ _{JB}	Junction-to-board characterization parameter ⁽⁶⁾	28.8	23.8	
θ _{JCbot}	Junction-to-case (bottom) thermal resistance ⁽⁷⁾	3.3	0.3	

(1) For more information about traditional and new thermal metrics, see the *IC Package Thermal Metrics* application report, [SPRA953](#).

(2) The junction-to-ambient thermal resistance under natural convection is obtained in a simulation on a JEDEC-standard, high-K board, as specified in JESD51-7, in an environment described in JESD51-2a.

(3) The junction-to-case (top) thermal resistance is obtained by simulating a cold plate test on the package top. No specific JEDEC-standard test exists, but a close description can be found in the ANSI SEMI standard G30-88.

(4) The junction-to-board thermal resistance is obtained by simulating in an environment with a ring cold plate fixture to control the PCB temperature, as described in JESD51-8.

(5) The junction-to-top characterization parameter, ψ_{JT}, estimates the junction temperature of a device in a real system and is extracted from the simulation data for obtaining θ_{JA}, using a procedure described in JESD51-2a (sections 6 and 7).

(6) The junction-to-board characterization parameter, ψ_{JB}, estimates the junction temperature of a device in a real system and is extracted from the simulation data for obtaining θ_{JA}, using a procedure described in JESD51-2a (sections 6 and 7).

(7) The junction-to-case (bottom) thermal resistance is obtained by simulating a cold plate test on the exposed (power) pad. No specific JEDEC standard test exists, but a close description can be found in the ANSI SEMI standard G30-88.

ELECTRICAL CHARACTERISTICS

 $-40^{\circ}\text{C} \leq T_J \leq 125^{\circ}\text{C}$, $V_{IN} = 48\text{ V}$ (unless otherwise stated)

PARAMETER	CONDITIONS	MIN	TYP	MAX	UNITS		
$V_{IN-UVLO-UPPER}$	VIN pin under-voltage lockout (UVLO) upper threshold	4.06	4.78	5.30	V		
$V_{IN-UVLO-HYS}$	VIN pin UVLO hysteresis		0.52		V		
I_{IN}	Operating current to the VIN pin		550	640	μA		
V_{SEN}	SEN pin voltage regulation	$V_{EQ} = 200\text{ mV}$, $T_A = 25^{\circ}\text{C}$		197.1	200	201.0	mV
		$V_{EQ} = 200\text{ mV}$		195.6	200	201.5	
I_{SEN}	SEN pin bias current out	$V_{SEN} = 0\text{ V}$		9.35	10.29	11.23	μA
$I_{LED-OFF}$	ILED pin off current	$V_{ILED} = 70\text{ V}$			0.1	0.6	μA
$R_{DS(on)}$	Integrated power MOSFET on-resistance	$I_{ILED} = 300\text{ mA}$			0.5	1.2	Ω
$V_{SRC-OPEN}$	SRC pin open circuit threshold	$V_{SEN} = V_{SRC}$, $V_{COMM} = 0\text{ V}$		25	31	37	mV
I_{LIMIT}	Current limit	$V_{SEN} = V_{SRC} = 0\text{ V}$, $V_{ILED} = 3\text{ V}$		1.75	2.06	2.35	A
$COMM_{LOW}$	COMM pin pull-low current	$V_{COMM} = 5\text{ V}$			34	54	μA
$COMM_{VHIGH}$	COMM pin pull-high voltage	COMM pin to ground through a 10-k Ω resistor			6.0		V
T_{SD}	Thermal shutdown		150				$^{\circ}\text{C}$

Connection Diagrams

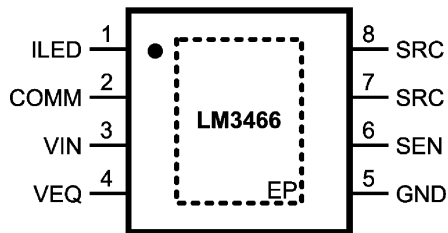

Figure 1. DDA (SO PowerPAD) Package, 8 Pins (Top View)

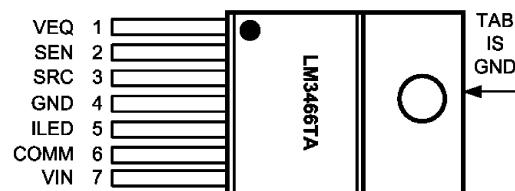

Figure 2. NEC (TO-220) Package, 7 Pins (Top View)

PIN DESCRIPTIONS

NAME	PINS		I/O	DESCRIPTION
	DDA	NEC		
COMM	2	6	O	Open-drain status output. Indicates the status of the LM3466 including startup, LED string active/inactive, thermal shutdown.
GND	5	4	—	Ground. Connects to ground.
ILED	1	5	I	Current regulator input. Connects to the drain of the integrated power MOSFET. Connects this pin to the cathode of an LED string. Connects a capacitor from this pin to ground to minimize noise if the connecting cable to the LED string is long.
SEN	6	2	I	Current sense input. Senses the voltage of an external current sensing resistor.
SRC	7	3	O	Source of power MOSFET. Connects to the source of the integrated power MOSFET. Connect this pin to an external current sensing resistor.
	8			
VEQ	4	1	O	Control voltage. Connects to the VEQ pin of other LM3466 with a 51- Ω resistor in series with a 1- μF capacitor to ground.
VIN	3	7	I	Input voltage supply. Connects to voltage supply from 6 V to 70 V. Connects a 10-nF capacitor from this pin to ground for decoupling.
Thermal Pad			—	Thermal connection pad. Connects to a ground plane.

TYPICAL CHARACTERISTICS

Unless otherwise specified the following conditions apply: $T_J = 25^\circ\text{C}$, $V_{IN} = 48\text{V}$ with configuration in the additional application circuit for $I_{LED} = 0.35\text{A}$ shown in this datasheet.

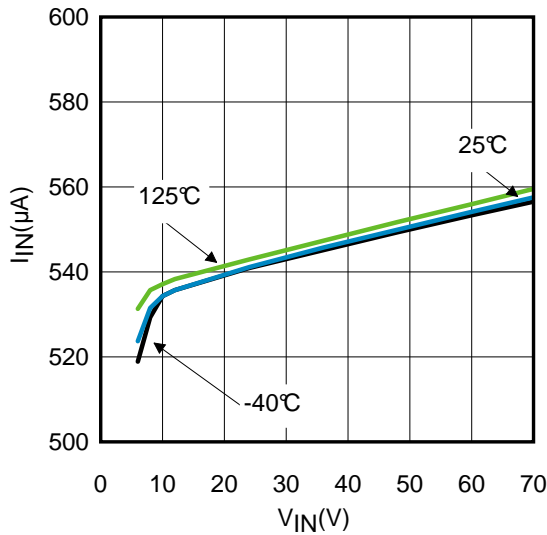

Figure 3. Quiescent Current, I_{IN} vs V_{IN}

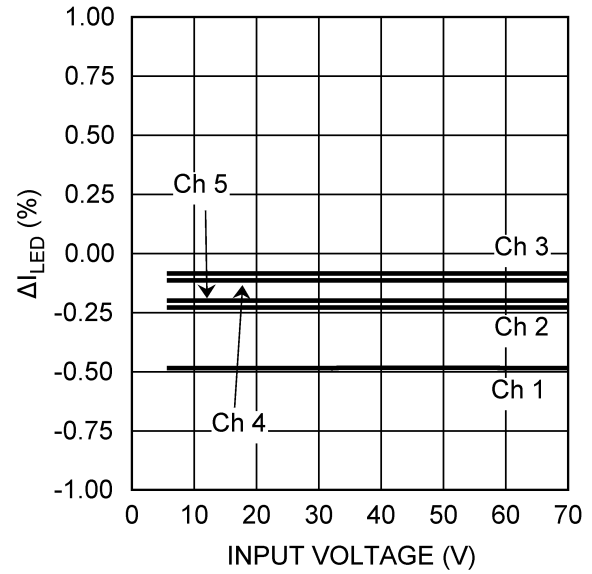

Figure 4. Current Regulation vs V_{IN}

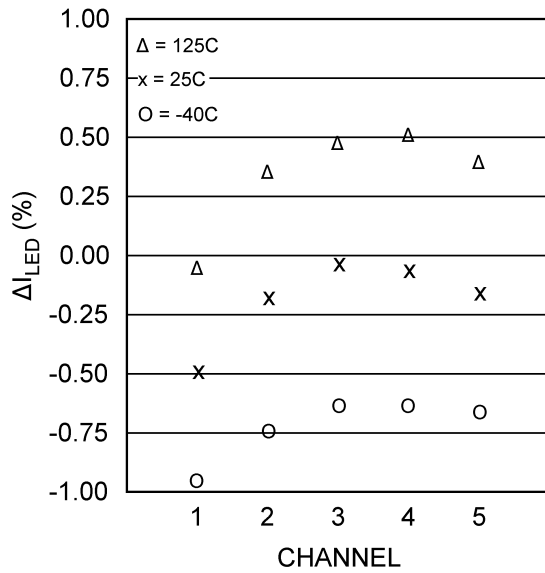

Figure 5. Current Regulation (Channel to Channel) vs Temperature

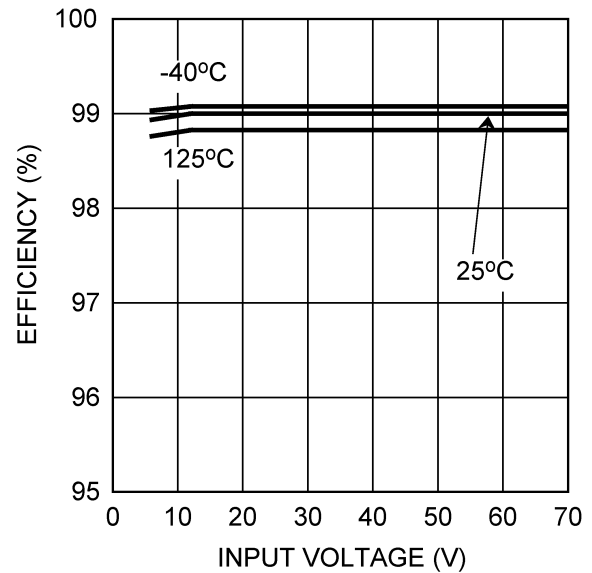

Figure 6. Efficiency vs V_{IN}

TYPICAL CHARACTERISTICS (continued)

Unless otherwise specified the following conditions apply: $T_J = 25^\circ\text{C}$, $V_{IN} = 48\text{V}$ with configuration in the additional application circuit for $I_{LED} = 0.35\text{A}$ shown in this datasheet.

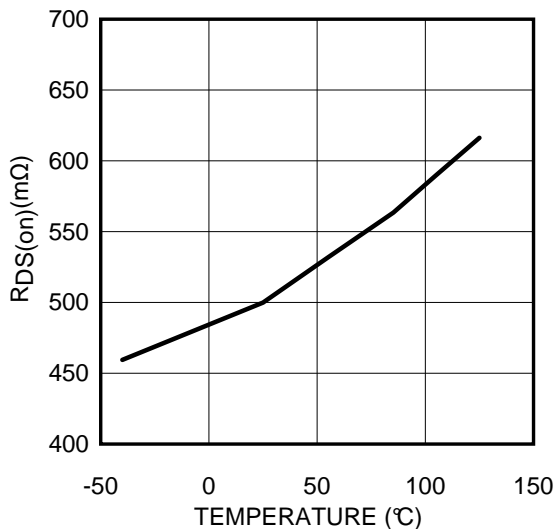

Figure 7. $R_{DS(on)}$ vs Temperature

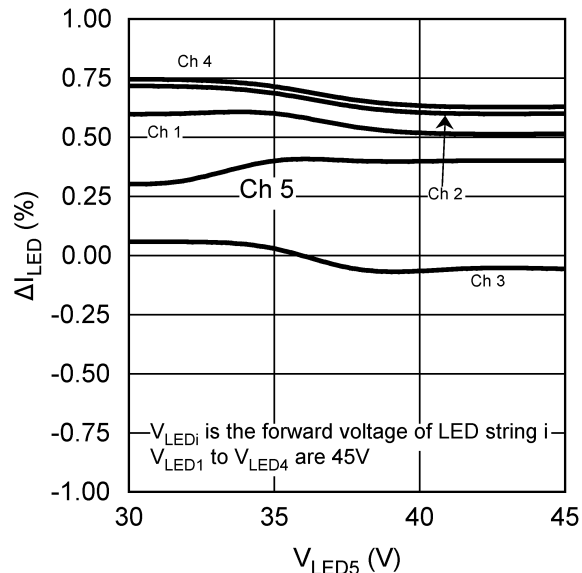
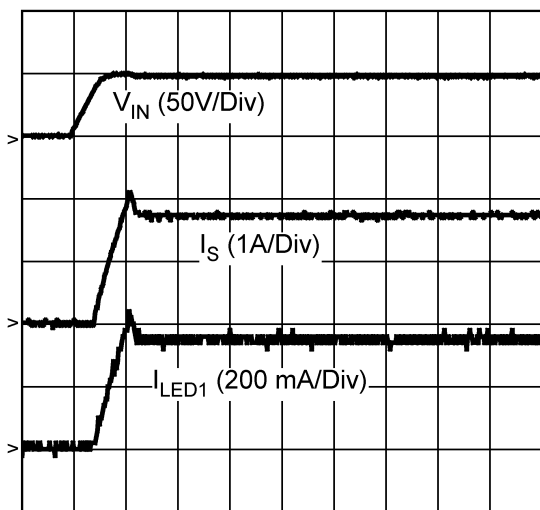
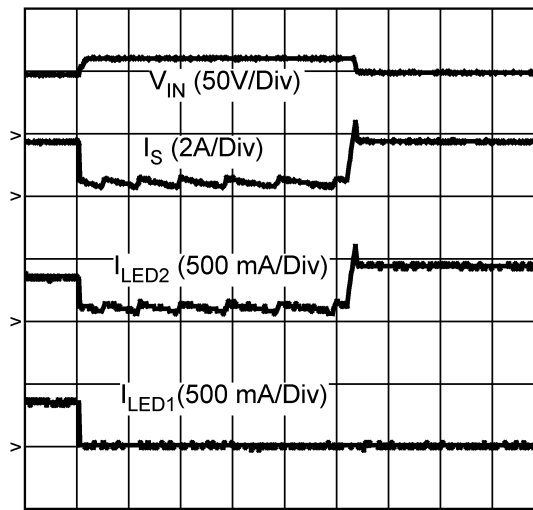

Figure 8. Current Regulation vs V_{LED}



TIME (20 ms/DIV)
Figure 9. Power Up



TIME (100 ms/DIV)
Figure 10. LED String Disconnect

TYPICAL CHARACTERISTICS (continued)

Unless otherwise specified the following conditions apply: $T_J = 25^\circ\text{C}$, $V_{IN} = 48\text{V}$ with configuration in the additional application circuit for $I_{LED} = 0.35\text{A}$ shown in this datasheet.

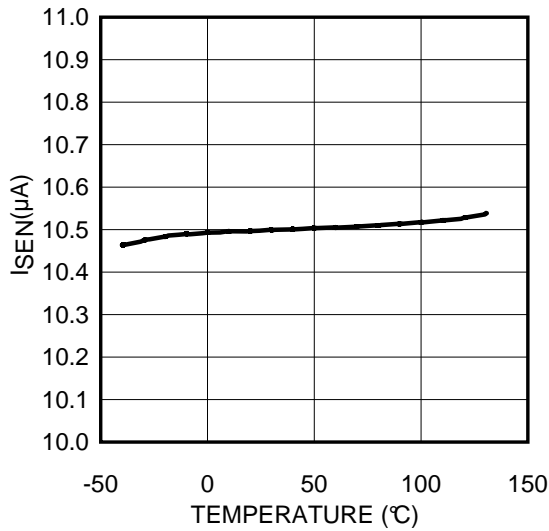

Figure 11. I_{SEN} vs Temperature

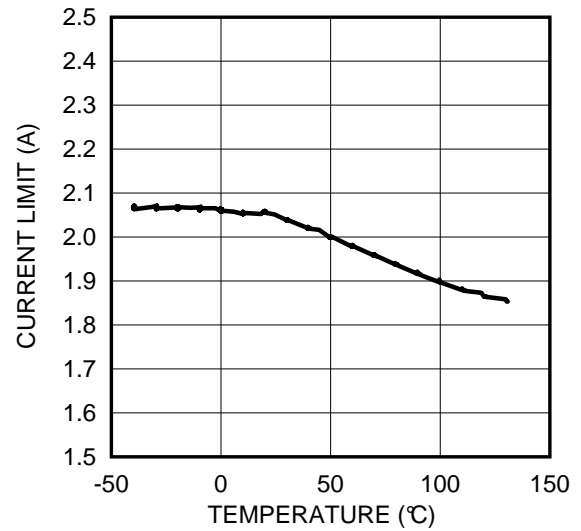
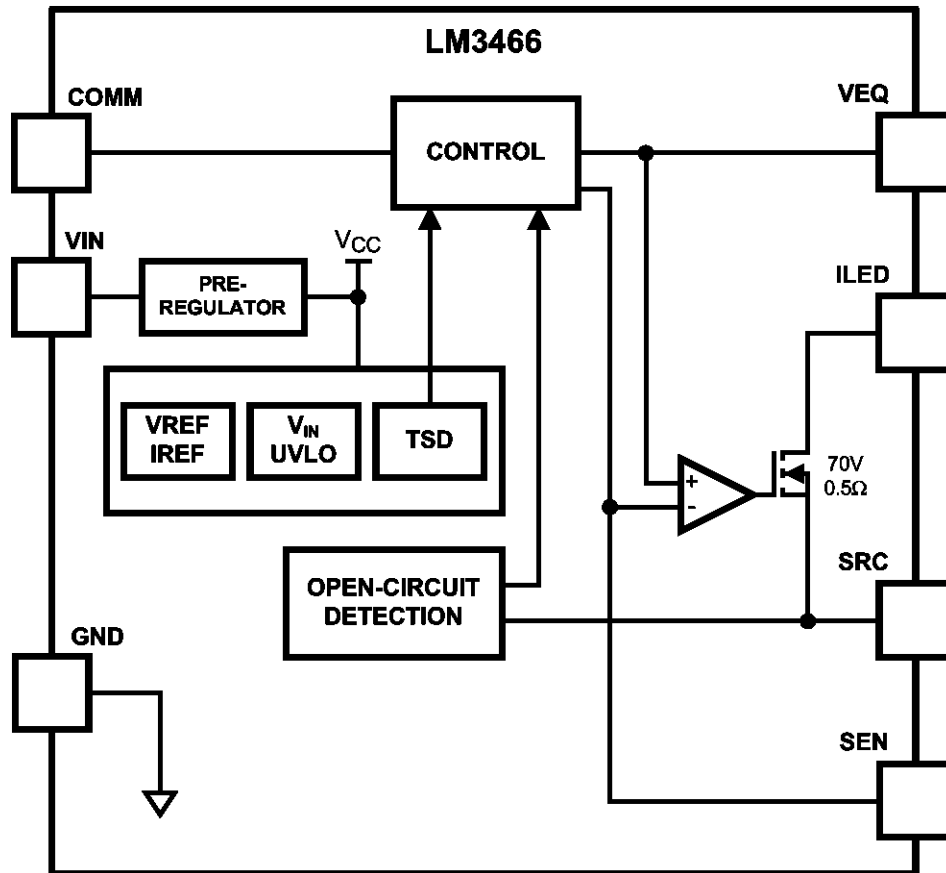

Figure 12. Current Limit vs Temperature

BLOCK DIAGRAM



OVERVIEW

The LM3466 integrates a linear LED driver for lighting systems which consist of multiple LED strings powered by a constant current power supply. An ideal constant current power supply delivers a constant current (I_S) regardless of the output voltage of the connecting load. In the lighting system, each device regulates the current of an LED string. The current I_S provided by the supply is balanced (i.e. shared in a pre-set ratio determined by a single resistor) through each active LED string automatically, regardless of the number of strings connected to the supply or the forward voltage of each string. Here, an active LED string refers to a fully turned on LED string. If any LED string opens during operation, the LED current of all remaining active LED strings will increase to balance the current provided by the supply automatically. As a result, the total output power remains nearly the same in case of the decrease of active LED strings. This gives an advantage that the overall brightness of the lighting system is maintained even if some LED strings open during operation.

A LM3466 lighting system is simple to design owing to a proprietary control scheme. To minimize the component count, the LM3466 integrates a 70-V, 1.5-A, N-channel MOSFET with a current limit of 2.06 A. To add one more LED string to the system, only a single resistor, a capacitor, and an additional LM3466 device are required. Other supervisory features of the LM3466 include under-voltage lock-out, fault reporting, thermal latchoff, and thermal shutdown protection.

The LM3466 consists of only linear circuitry so that the EMI of the application circuit is not deteriorated. The LM3466 lighting system is EMI friendly if the constant current power supply used is complied to EMI standards. The LM3466 is available in a DDA thermal pad and NEC packages.

Current Regulator

The LM3466 integrates a current regulator to control the current of a connected LED string. The current is delivered from the supply through the LED string, the ILED pin, the integrated power MOSFET, the SRC pin, and the sensing resistor R_{SEN} connecting from the SRC pin to ground as shown in [Figure 13](#). The sensing resistor voltage is fed back to the LM3466 through the SEN pin, either by direct connection or through an extra resistor R_{SL} . The device regulates the voltage of the SEN pin (V_{SEN}) to a voltage set by its control block. If the sensing resistor of each LM3466 ($R_{SEN,k}$, $k = 1, 2, \dots, n$) is the same, the LED current of each active LED string is the same. If $R_{SEN,k}$ of any device is different from others, the corresponding LED current ($I_{LED,k}$) is different, while V_{SEN} of each LM3466 remains the same as others. The LED current of string k is shown in [Equation 1](#).

$$I_{LED,k} = \frac{I_S R_{TOTAL}}{R_{SEN,k}}$$

where

- I_S is the current of the supply, and (1)

$$\frac{1}{R_{TOTAL}} = \sum_{i=1}^n \frac{1}{R_{SEN,i}} \quad (2)$$

In addition to determining the LED current from the $R_{SEN,k}$ resistor, an external resistor $R_{SL,k}$ connecting between the SEN pin and $R_{SEN,k}$ can be used to fine tune the LED current for the purpose of color temperature adjustment or CRI enhancement. The SEN pin sources a constant bias current I_{SEN} (typically 10.5 μ A for DDA package and 10.29 μ A for the NEC package) such that a constant voltage drop on $R_{SL,k}$ reduces the LED current. Using an external resistor $R_{SL,k}$ affects the current of other LED strings. If $R_{SL,k}$ is added in the k -th LM3466, the corresponding LED current is shown in [Equation 3](#).

$$I_{LED,k} = \left(\frac{(I_S \times R_{TOTAL}) - (I_{SEN} \times R_{SL,k} \times R_{TOTAL}) \times \left(\frac{1}{R_{TOTAL}} - \frac{1}{R_{SEN,k}} \right)}{R_{SEN,k}} \right) \quad (3)$$

and the LED current of other strings is shown in [Equation 4](#).

$$I_{LED,i} = \left(\frac{(I_S \times R_{TOTAL}) + \left(I_{SEN} \times \left(\frac{R_{SL,k} \times R_{TOTAL}}{R_{SEN,k}} \right) \right)}{R_{SEN,i}} \right)$$

where

- $i = 1, 2, \dots, n$ (except k) (4)

The LED current of LED string k is reduced, while the LED current of other channels increases. Figure 14 shows a typical example that the variation of LED current on varying $R_{SL,k}$.

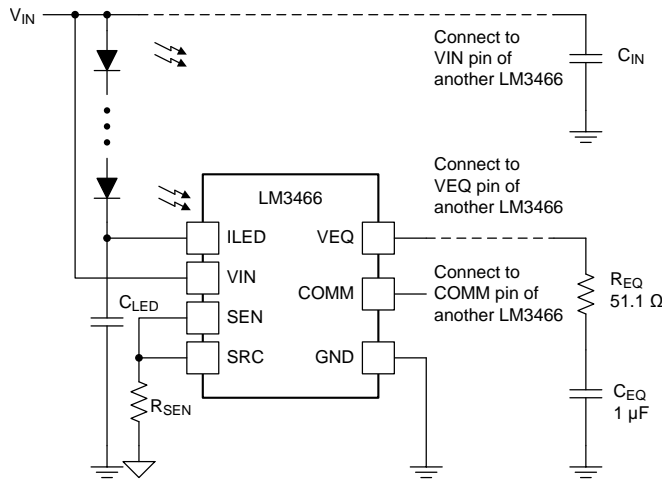

Figure 13. A Single LM3466 within a Lighting System

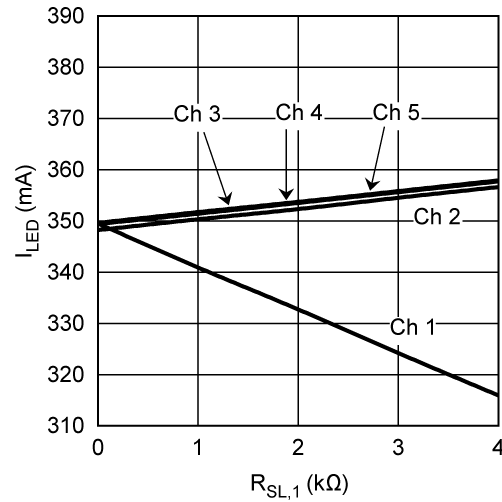

Figure 14. Variation of I_{LED} vs $R_{SL,k}$

LED String Disconnect and Reconnect

One major advantage of the LM3466 lighting system is that the overall brightness can be maintained even if some LED strings open during operation. If an active LED string is suddenly disconnected, the LM3466 automatically balances the current delivered by the supply I_S (i.e. each string increases its LED current in this case) so as to keep I_S constant. However, the current balancing occurs only after the LED string is confirmed inactive. Once the string is disconnected, V_{EQ} cycles (goes up and down). If the string remains disconnected for a period of 253 consecutive cycles, the string is confirmed inactive. Consequently, the current of other LED strings increases to balance I_S . The output power and the overall brightness of the lighting system can be maintained.

If a new LED string connects to the system, such as if the disconnected LED string is reconnected again, a power reset is recommended to ensure proper operation. The forward voltage of the new LED string may be higher than the instantaneous V_{IN} , which corresponds to the forward voltage of the highest active LED string. A power reset ensures that V_{IN} goes to the peak voltage (a default characteristic of a constant current power supply) in order to start up the LED string with the highest forward voltage.

Communication Pin (COMM)

The COMM pin serves as a communication link among all LM3466 in the lighting system. It also indicates the status of the device. The COMM pin is pulled low at startup. After startup, the COMM pin is high or low to indicate that the corresponding LED string is active or inactive.

For proper operation of an LM3466 lighting system, the COMM pin of all LM3466 should be either shorted together or connected through a diode in parallel with a resistor.

Figure 15 shows an optional circuit for the COMM pin to indicate whether each LED string is active by means of small signal LEDs. The COMM pin of each LM3466 is connected to an external test point COMM_ALL through the optional circuit.

The COMM pin is low if the LM3466 is under thermal protection.

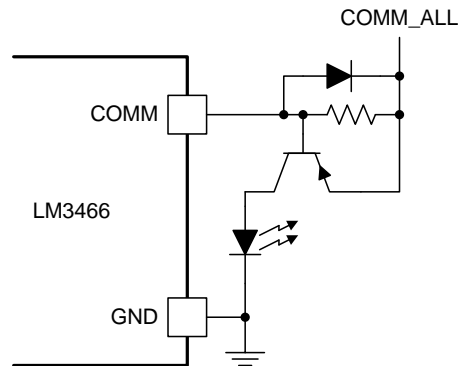

Figure 15. Optional Circuit for the COMM Pin

High Voltage Application

For any application with the forward voltage of an LED string higher than 70 V, which is the maximum operating voltage of the LM3466, an external MOSFET circuit as shown in Figure 16 is recommended for each channel in order to protect the ILED pin from damaging by a high voltage owing to shorting LEDs (or even the whole LED string). To avoid the ILED pin damage from a high voltage generated by the leakage current, a resistor R_{LED} (1 M Ω is suggested) is placed between the ILED pin and ground. In addition, because V_{LED} is higher than 70 V in this case, the VIN pin cannot be directly connected to V_{LED} . External power supplies for V_{IN} and V_G (to drive the external MOSFET) are required. Alternatively, as shown in Figure 17, a circuit for supplying V_{IN} and V_G (for all channels in the system).

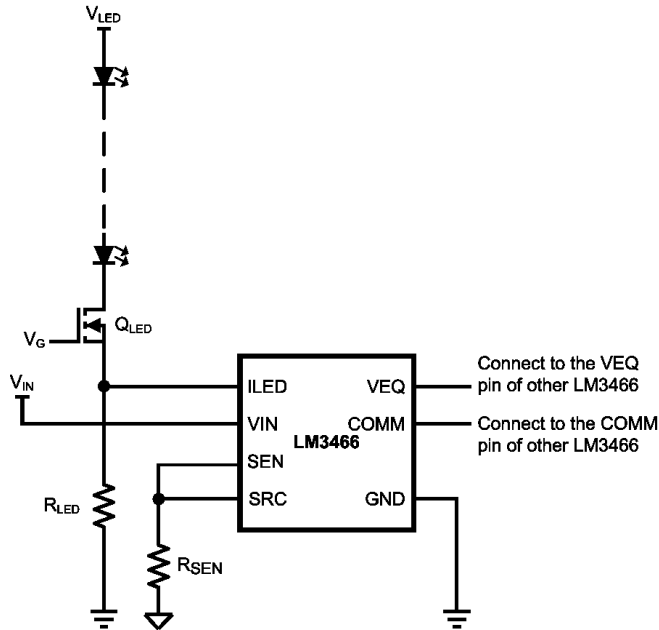

Figure 16. External MOSFET Circuit for High Voltage Applications

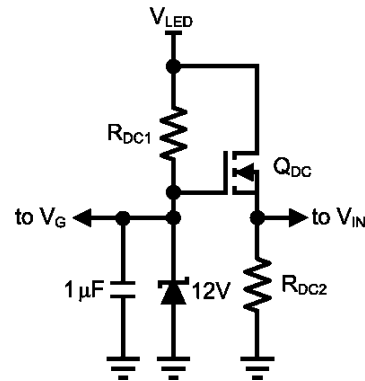

Figure 17. Power Supply Circuit for the External MOSFET Circuit

Thermal Protection

Thermal protection is implemented by an internal thermal shutdown circuit which activates at 150°C (typically) to disable the LM3466. In this case, the integrated power MOSFET turns off and the COMM pin is pulled low. Thermal protection helps prevent catastrophic failures from accidental device overheating. When the junction temperature of the LM3466 falls back below 140°C (typical hysteresis = 10°C), the LM3466 resumes normal operation.

Thermal Latch Off and Derating

If thermal protection cycles for 253 times consecutively, the LM3466 is latched off until power reset.

Thermal derating is required for only the DDA package (but not the NEC package). When fully turned on, the integrated power MOSFET of the LM3466 is capable of conducting a current of 1.5 A below an ambient temperature of 100°C. At 125°C, the LM3466 can conduct a current of 1 A without thermal shutdown with a PCB ground plane copper area of 60 cm², 2 oz/Cu. Figure 18 shows a thermal derating curve for the minimum conducting current of a fully turned on LM3466 integrated power MOSFET without thermal shutdown against an ambient temperature up to 125°C.

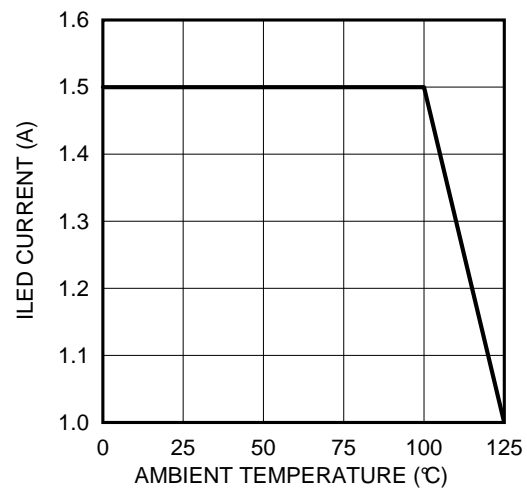

Figure 18. Thermal Derating Curve for the eDDA-8 Package

APPLICATION INFORMATION

Consider a LM3466 lighting system which is powered by a 1.75 A constant current power supply and consists of 5 LED strings with 14 LEDs per string. It is designed that the LED current of every LED string is 0.35 A.

EXTERNAL COMPONENTS

R_{SEN}: To set the LED current of all 5 LED strings equal, the sensing resistors corresponding to all 5 LM3466 are equal. It is recommended that the nominal voltage of the SEN pin V_{SEN} should be around 0.3 V. Therefore, R_{SEN} is selected to be 1 Ω. As a result, V_{SEN} should be 0.35 V if the LED current is 0.35 A.

C_{LED}: If the cable connecting the LED string is long, the parasitic inductance of the cable may generate noise. If this happens, a high quality ceramic capacitor should be connected between the ILED pin and ground. In this example, a 100 V, 1 μF ceramic capacitor is used.

C_{IN}: A high quality ceramic capacitor for decoupling should be connected from the VIN pin to ground. In this example, a 100 V, 0.01 μF ceramic capacitor is used.

R_{EQ} and C_{EQ}: The VEQ pins of all LM3466 are shorted together and then connected to ground through R_{EQ} and C_{EQ}. Only one R_{EQ} and one C_{EQ} are required for each LM3466 lighting system. It is recommended that R_{EQ} be 51.1 Ω and C_{EQ} be 1 μF.

PC BOARD LAYOUT

To minimize the effect of noise, the ground connections of the LM3466 and the sense resistor R_{SEN,k} should be closed. Good heat dissipation helps optimize the performance of the LM3466. The ground plane should be used to connect the exposed pad of the LM3466, which is internally connected to the LM3466 die substrate. The area of the ground plane should be extended as much as possible on the same copper layer above and below the LM3466. Using numerous vias beneath the exposed pad to dissipate heat of the LM3466 to another copper layer is also a good practice.

Additional Application Circuit

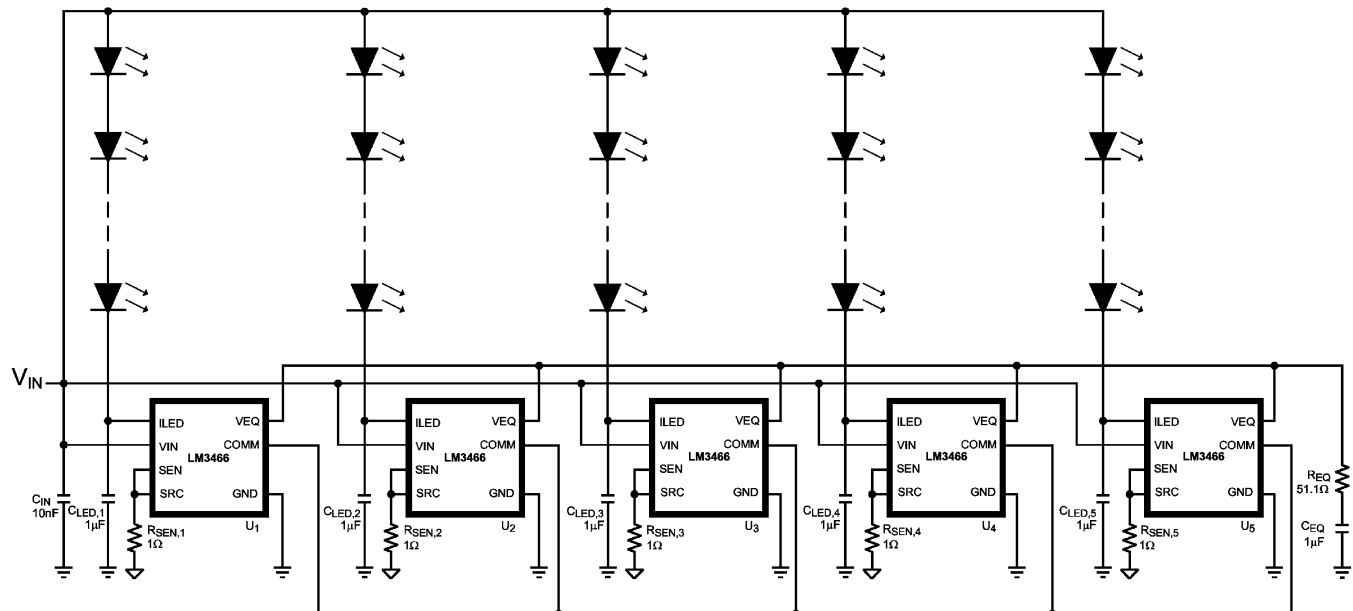

Figure 19. Application Circuit of a LM3466 Lighting System

REVISION HISTORY

Changes from Revision C (May 2013) to Revision D Page

- Changed layout of National Data Sheet to TI format 13
-

Changes from Revision D (MAY 2013) to Revision E Page

- Changed title 1
 - Changed updated layout to TI standards 1
 - Changed updated [SIMPLIFIED APPLICATION](#) 1
 - Added updated Thermal Table 2
 - Changed updated [Equation 3](#) 8
 - Changed updated [Equation 4](#) 8
 - Changed updated [Figure 13](#) 9
-

Changes from Revision E (AUGUST 2013) to Revision F Page

- Changed Electrical Characteristics table. Updated current sense specification. 3
-

PACKAGING INFORMATION

Orderable Device	Status (1)	Package Type	Package Drawing	Pins	Package Qty	Eco Plan (2)	Lead/Ball Finish	MSL Peak Temp (3)	Op Temp (°C)	Device Marking (4/5)	Samples
LM3466MR/NOPB	ACTIVE	SO PowerPAD	DDA	8	95	Green (RoHS & no Sb/Br)	CU SN	Level-3-260C-168 HR	-40 to 125	L3466	Samples
LM3466MRX/NOPB	ACTIVE	SO PowerPAD	DDA	8	2500	Green (RoHS & no Sb/Br)	CU SN	Level-3-260C-168 HR	-40 to 125	L3466	Samples
LM3466TA/NOPB	ACTIVE	TO-220	NEC	7	45	Green (RoHS & no Sb/Br)	CU SN	Level-1-NA-UNLIM		LM3466 TA	Samples

(1) The marketing status values are defined as follows:

ACTIVE: Product device recommended for new designs.

LIFEBUY: TI has announced that the device will be discontinued, and a lifetime-buy period is in effect.

NRND: Not recommended for new designs. Device is in production to support existing customers, but TI does not recommend using this part in a new design.

PREVIEW: Device has been announced but is not in production. Samples may or may not be available.

OBSOLETE: TI has discontinued the production of the device.

(2) Eco Plan - The planned eco-friendly classification: Pb-Free (RoHS), Pb-Free (RoHS Exempt), or Green (RoHS & no Sb/Br) - please check <http://www.ti.com/productcontent> for the latest availability information and additional product content details.

TBD: The Pb-Free/Green conversion plan has not been defined.

Pb-Free (RoHS): TI's terms "Lead-Free" or "Pb-Free" mean semiconductor products that are compatible with the current RoHS requirements for all 6 substances, including the requirement that lead not exceed 0.1% by weight in homogeneous materials. Where designed to be soldered at high temperatures, TI Pb-Free products are suitable for use in specified lead-free processes.

Pb-Free (RoHS Exempt): This component has a RoHS exemption for either 1) lead-based flip-chip solder bumps used between the die and package, or 2) lead-based die adhesive used between the die and leadframe. The component is otherwise considered Pb-Free (RoHS compatible) as defined above.

Green (RoHS & no Sb/Br): TI defines "Green" to mean Pb-Free (RoHS compatible), and free of Bromine (Br) and Antimony (Sb) based flame retardants (Br or Sb do not exceed 0.1% by weight in homogeneous material)

(3) MSL, Peak Temp. -- The Moisture Sensitivity Level rating according to the JEDEC industry standard classifications, and peak solder temperature.

(4) There may be additional marking, which relates to the logo, the lot trace code information, or the environmental category on the device.

(5) Multiple Device Markings will be inside parentheses. Only one Device Marking contained in parentheses and separated by a "~" will appear on a device. If a line is indented then it is a continuation of the previous line and the two combined represent the entire Device Marking for that device.

Important Information and Disclaimer: The information provided on this page represents TI's knowledge and belief as of the date that it is provided. TI bases its knowledge and belief on information provided by third parties, and makes no representation or warranty as to the accuracy of such information. Efforts are underway to better integrate information from third parties. TI has taken and continues to take reasonable steps to provide representative and accurate information but may not have conducted destructive testing or chemical analysis on incoming materials and chemicals. TI and TI suppliers consider certain information to be proprietary, and thus CAS numbers and other limited information may not be available for release.

In no event shall TI's liability arising out of such information exceed the total purchase price of the TI part(s) at issue in this document sold by TI to Customer on an annual basis.

TAPE AND REEL INFORMATION



QUADRANT ASSIGNMENTS FOR PIN 1 ORIENTATION IN TAPE



*All dimensions are nominal

Device	Package Type	Package Drawing	Pins	SPQ	Reel Diameter (mm)	Reel Width W1 (mm)	A0 (mm)	B0 (mm)	K0 (mm)	P1 (mm)	W (mm)	Pin1 Quadrant
LM3466MRX/NOPB	SO Power PAD	DDA	8	2500	330.0	12.4	6.5	5.4	2.0	8.0	12.0	Q1

TAPE AND REEL BOX DIMENSIONS



*All dimensions are nominal

Device	Package Type	Package Drawing	Pins	SPQ	Length (mm)	Width (mm)	Height (mm)
LM3466MRX/NOPB	SO PowerPAD	DDA	8	2500	367.0	367.0	35.0

DDA0008A

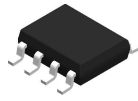

PACKAGE OUTLINE

PowerPAD™ SOIC - 1.7 mm max height

PLASTIC SMALL OUTLINE

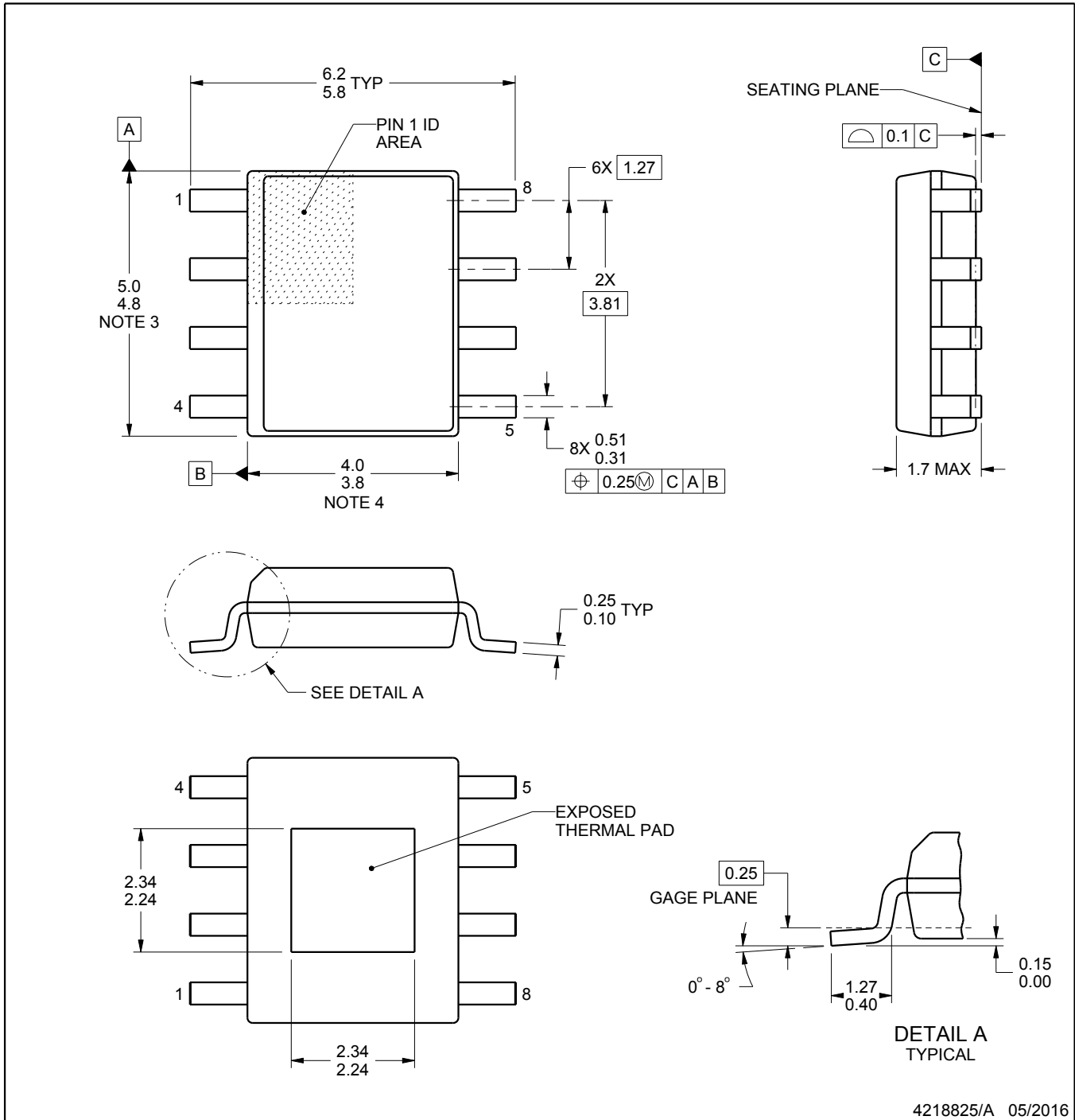

4218825/A 05/2016

PowerPAD is a trademark of Texas Instruments.

NOTES:

1. All linear dimensions are in millimeters. Any dimensions in parenthesis are for reference only. Dimensioning and tolerancing per ASME Y14.5M.
2. This drawing is subject to change without notice.
3. This dimension does not include mold flash, protrusions, or gate burrs. Mold flash, protrusions, or gate burrs shall not exceed 0.15 mm per side.
4. This dimension does not include interlead flash. Interlead flash shall not exceed 0.25 mm per side.
5. Reference JEDEC registration MS-012.

EXAMPLE BOARD LAYOUT

DDA0008A

PowerPAD™ SOIC - 1.7 mm max height

PLASTIC SMALL OUTLINE

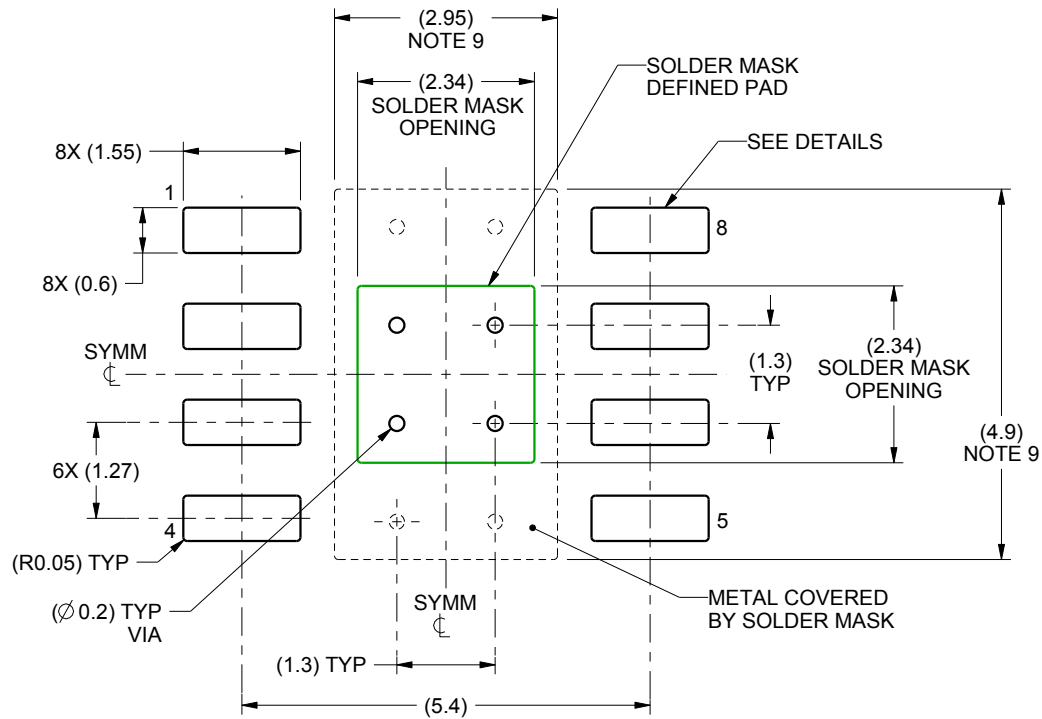

LAND PATTERN EXAMPLE
SCALE:10X

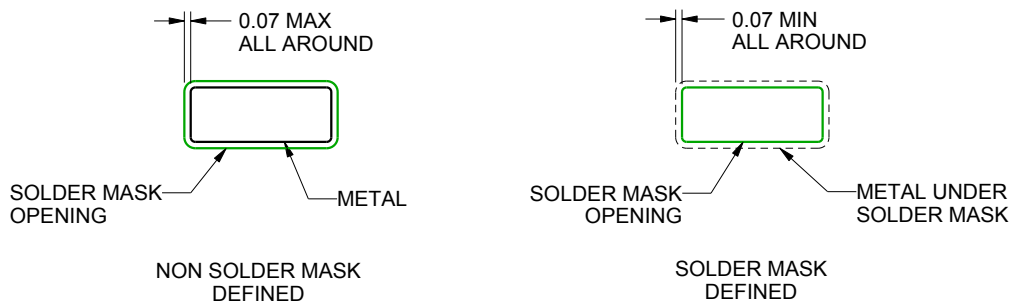

SOLDER MASK DETAILS

4218825/A 05/2016

NOTES: (continued)

6. Publication IPC-7351 may have alternate designs.
7. Solder mask tolerances between and around signal pads can vary based on board fabrication site.
8. This package is designed to be soldered to a thermal pad on the board. For more information, see Texas Instruments literature numbers SLMA002 (www.ti.com/lit/slma002) and SLMA004 (www.ti.com/lit/slma004).
9. Size of metal pad may vary due to creepage requirement.
10. Vias are optional depending on application, refer to device data sheet. If any vias are implemented, refer to their locations shown on this view. It is recommended that vias under paste be filled, plugged or tented.

EXAMPLE STENCIL DESIGN

DDA0008A

PowerPAD™ SOIC - 1.7 mm max height

PLASTIC SMALL OUTLINE

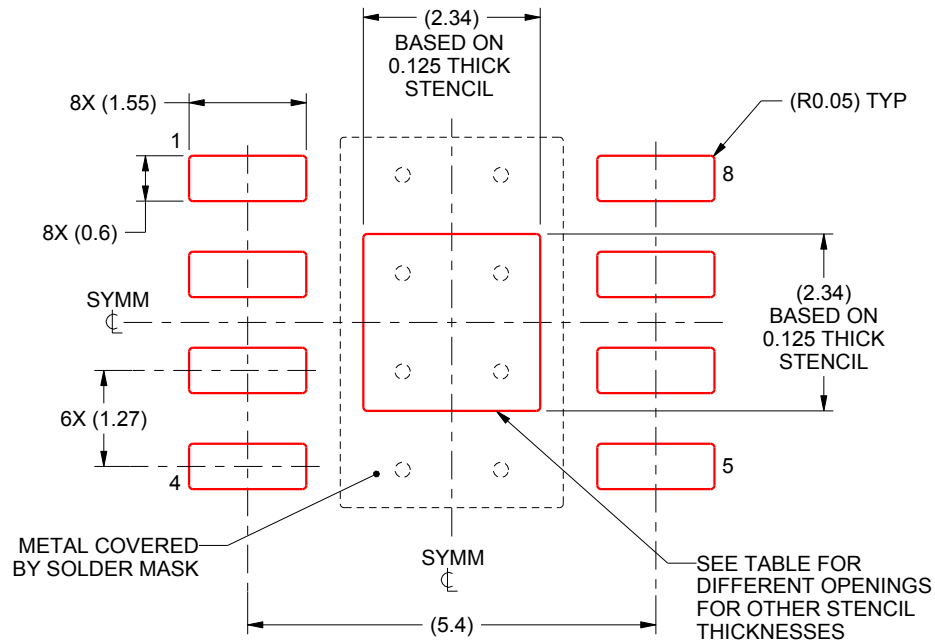

SOLDER PASTE EXAMPLE
EXPOSED PAD
100% PRINTED SOLDER COVERAGE BY AREA
SCALE:10X

STENCIL THICKNESS	SOLDER STENCIL OPENING
0.1	2.62 X 2.62
0.125	2.34 X 2.34 (SHOWN)
0.150	2.14 X 2.14
0.175	1.98 X 1.98

4218825/A 05/2016

NOTES: (continued)

11. Laser cutting apertures with trapezoidal walls and rounded corners may offer better paste release. IPC-7525 may have alternate design recommendations.
12. Board assembly site may have different recommendations for stencil design.

NEC0007A

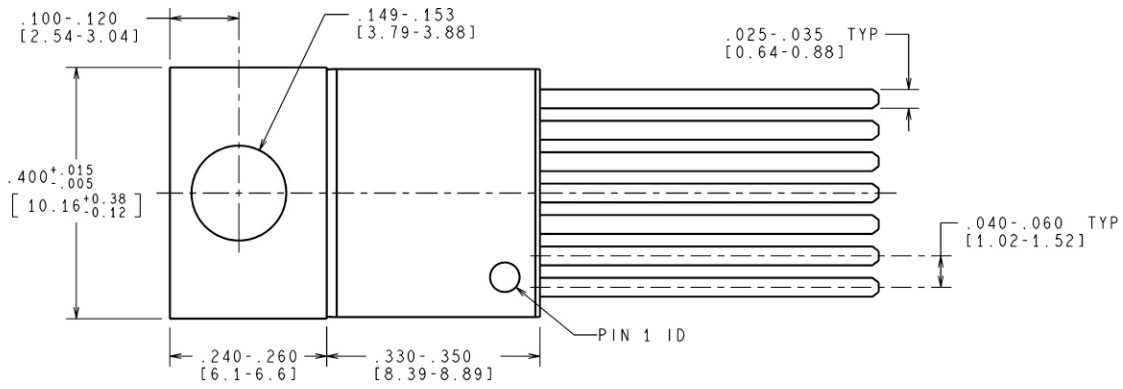

CONTROLLING DIMENSION IS INCH
VALUES IN [] ARE MILLIMETERS

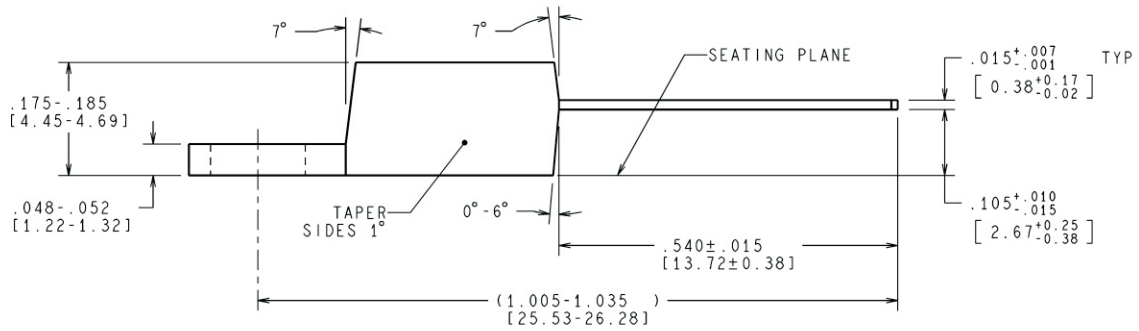

TA07A (Rev A)

IMPORTANT NOTICE

Texas Instruments Incorporated (TI) reserves the right to make corrections, enhancements, improvements and other changes to its semiconductor products and services per JESD46, latest issue, and to discontinue any product or service per JESD48, latest issue. Buyers should obtain the latest relevant information before placing orders and should verify that such information is current and complete.

TI's published terms of sale for semiconductor products (<http://www.ti.com/sc/docs/stdterms.htm>) apply to the sale of packaged integrated circuit products that TI has qualified and released to market. Additional terms may apply to the use or sale of other types of TI products and services.

Reproduction of significant portions of TI information in TI data sheets is permissible only if reproduction is without alteration and is accompanied by all associated warranties, conditions, limitations, and notices. TI is not responsible or liable for such reproduced documentation. Information of third parties may be subject to additional restrictions. Resale of TI products or services with statements different from or beyond the parameters stated by TI for that product or service voids all express and any implied warranties for the associated TI product or service and is an unfair and deceptive business practice. TI is not responsible or liable for any such statements.

Buyers and others who are developing systems that incorporate TI products (collectively, "Designers") understand and agree that Designers remain responsible for using their independent analysis, evaluation and judgment in designing their applications and that Designers have full and exclusive responsibility to assure the safety of Designers' applications and compliance of their applications (and of all TI products used in or for Designers' applications) with all applicable regulations, laws and other applicable requirements. Designer represents that, with respect to their applications, Designer has all the necessary expertise to create and implement safeguards that (1) anticipate dangerous consequences of failures, (2) monitor failures and their consequences, and (3) lessen the likelihood of failures that might cause harm and take appropriate actions. Designer agrees that prior to using or distributing any applications that include TI products, Designer will thoroughly test such applications and the functionality of such TI products as used in such applications.

TI's provision of technical, application or other design advice, quality characterization, reliability data or other services or information, including, but not limited to, reference designs and materials relating to evaluation modules, (collectively, "TI Resources") are intended to assist designers who are developing applications that incorporate TI products; by downloading, accessing or using TI Resources in any way, Designer (individually or, if Designer is acting on behalf of a company, Designer's company) agrees to use any particular TI Resource solely for this purpose and subject to the terms of this Notice.

TI's provision of TI Resources does not expand or otherwise alter TI's applicable published warranties or warranty disclaimers for TI products, and no additional obligations or liabilities arise from TI providing such TI Resources. TI reserves the right to make corrections, enhancements, improvements and other changes to its TI Resources. TI has not conducted any testing other than that specifically described in the published documentation for a particular TI Resource.

Designer is authorized to use, copy and modify any individual TI Resource only in connection with the development of applications that include the TI product(s) identified in such TI Resource. NO OTHER LICENSE, EXPRESS OR IMPLIED, BY ESTOPPEL OR OTHERWISE TO ANY OTHER TI INTELLECTUAL PROPERTY RIGHT, AND NO LICENSE TO ANY TECHNOLOGY OR INTELLECTUAL PROPERTY RIGHT OF TI OR ANY THIRD PARTY IS GRANTED HEREIN, including but not limited to any patent right, copyright, mask work right, or other intellectual property right relating to any combination, machine, or process in which TI products or services are used. Information regarding or referencing third-party products or services does not constitute a license to use such products or services, or a warranty or endorsement thereof. Use of TI Resources may require a license from a third party under the patents or other intellectual property of the third party, or a license from TI under the patents or other intellectual property of TI.

TI RESOURCES ARE PROVIDED "AS IS" AND WITH ALL FAULTS. TI DISCLAIMS ALL OTHER WARRANTIES OR REPRESENTATIONS, EXPRESS OR IMPLIED, REGARDING RESOURCES OR USE THEREOF, INCLUDING BUT NOT LIMITED TO ACCURACY OR COMPLETENESS, TITLE, ANY EPIDEMIC FAILURE WARRANTY AND ANY IMPLIED WARRANTIES OF MERCHANTABILITY, FITNESS FOR A PARTICULAR PURPOSE, AND NON-INFRINGEMENT OF ANY THIRD PARTY INTELLECTUAL PROPERTY RIGHTS. TI SHALL NOT BE LIABLE FOR AND SHALL NOT DEFEND OR INDEMNIFY DESIGNER AGAINST ANY CLAIM, INCLUDING BUT NOT LIMITED TO ANY INFRINGEMENT CLAIM THAT RELATES TO OR IS BASED ON ANY COMBINATION OF PRODUCTS EVEN IF DESCRIBED IN TI RESOURCES OR OTHERWISE. IN NO EVENT SHALL TI BE LIABLE FOR ANY ACTUAL, DIRECT, SPECIAL, COLLATERAL, INDIRECT, PUNITIVE, INCIDENTAL, CONSEQUENTIAL OR EXEMPLARY DAMAGES IN CONNECTION WITH OR ARISING OUT OF TI RESOURCES OR USE THEREOF, AND REGARDLESS OF WHETHER TI HAS BEEN ADVISED OF THE POSSIBILITY OF SUCH DAMAGES.

Unless TI has explicitly designated an individual product as meeting the requirements of a particular industry standard (e.g., ISO/TS 16949 and ISO 26262), TI is not responsible for any failure to meet such industry standard requirements.



Where TI specifically promotes products as facilitating functional safety or as compliant with industry functional safety standards, such products are intended to help enable customers to design and create their own applications that meet applicable functional safety standards and requirements. Using products in an application does not by itself establish any safety features in the application. Designers must ensure compliance with safety-related requirements and standards applicable to their applications. Designer may not use any TI products in life-critical medical equipment unless authorized officers of the parties have executed a special contract specifically governing such use. Life-critical medical equipment is medical equipment where failure of such equipment would cause serious bodily injury or death (e.g., life support, pacemakers, defibrillators, heart pumps, neurostimulators, and implantables). Such equipment includes, without limitation, all medical devices identified by the U.S. Food and Drug Administration as Class III devices and equivalent classifications outside the U.S.

TI may expressly designate certain products as completing a particular qualification (e.g., Q100, Military Grade, or Enhanced Product). Designers agree that it has the necessary expertise to select the product with the appropriate qualification designation for their applications and that proper product selection is at Designers' own risk. Designers are solely responsible for compliance with all legal and regulatory requirements in connection with such selection.

Designer will fully indemnify TI and its representatives against any damages, costs, losses, and/or liabilities arising out of Designer's non-compliance with the terms and provisions of this Notice.

Looking for pricing, stock, or lifecycle information?

Click below to explore more details on WIN SOURCE:

-  [View LM3466MR/NOPB on WIN SOURCE](#)
-  [Texas Instruments](#) Information

Optimize Your Supply Chain with WIN SOURCE Solutions

-  Global Sourcing Solution
-  Obsolete Management
-  Cost Control Management
-  Shortage Management
-  Alternative Solution
-  Excess Inventory Management