



**THE DATASHEET OF
LM3420M5X-8.4/NOPB**



Table of Contents

1 Features 1 2 Applications 1 3 Description 1 4 Revision History 2 5 Pin Configuration and Functions 3 6 Specifications 4 6.1 Absolute Maximum Ratings 4 6.2 ESD Ratings..... 4 6.3 Recommended Operating Conditions 4 6.4 Thermal Information 4 6.5 LM3420 Electrical Characteristics 5 6.6 LM3420A Electrical Characteristics 6 6.7 Typical Characteristics 7 7 Parameter Measurement Information 9 7.1 Test Circuits 9 8 Detailed Description 10 8.1 Overview 10	8.2 Functional Block Diagram 10 8.3 Feature Description..... 10 8.4 Device Functional Modes..... 11 9 Application and Implementation 12 9.1 Application Information..... 12 9.2 Typical Application: Constant Current/Constant Voltage Li-Ion Battery Charger 12 10 Power Supply Recommendations 17 11 Layout 18 11.1 Layout Guidelines 18 11.2 Layout Example 18 12 Device and Documentation Support 18 12.1 Trademarks 18 12.2 Electrostatic Discharge Caution 18 12.3 Glossary 18 13 Mechanical, Packaging, and Orderable Information 19
---	--

4 Revision History

NOTE: Page numbers for previous revisions may differ from page numbers in the current version.

Changes from Revision D (May 2013) to Revision E	Page
• Deleted info re: 4.2-V, 8.2-V, 12.6-V and 16.8 V versions	1
• Added <i>Device Information</i> and <i>ESD Ratings</i> tables, <i>Feature Description</i> , <i>Device Functional Modes</i> , <i>Application and Implementation</i> , <i>Power Supply Recommendations</i> , <i>Layout</i> , <i>Device and Documentation Support</i> , and <i>Mechanical, Packaging, and Orderable Information</i> sections; moved some curves to <i>Application Curves</i> section	1

Changes from Revision C (April 2013) to Revision D	Page
• Changed layout of National Data Sheet to TI format	13

5 Pin Configuration and Functions

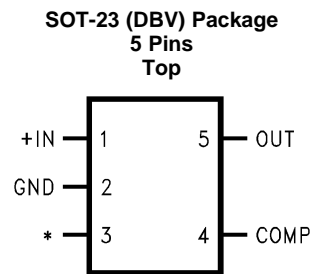

Pin Functions

PIN		I/O	DESCRIPTION
NAME	NUMBER		
IN	1	I	Input voltage supply
GND	2	—	Ground
NC	3	—	No connection
OUT	4	O	Open emitter output capable of sourcing current
COMP	5		Compensation

6 Specifications

6.1 Absolute Maximum Ratings

 over operating free-air temperature range (unless otherwise noted) ⁽¹⁾⁽²⁾

		MIN	MAX	UNIT
Input voltage V_{IN}			20	V
Output current			20	mA
Junction temperature			150	°C
Lead temperature	Vapor phase (60 seconds)		215	
	Infrared (15 seconds)		220	
Power dissipation ($T_A = 25^\circ\text{C}$) ⁽³⁾			300	mW
Storage temperature, T_{stg}		-65	150	°C

- Stresses beyond those listed under *Absolute Maximum Ratings* may cause permanent damage to the device. These are stress ratings only, which do not imply functional operation of the device at these or any other conditions beyond those indicated under *Recommended Operating Conditions*. Exposure to absolute-maximum-rated conditions for extended periods may affect device reliability.
- If Military/Aerospace specified devices are required, please contact the Texas Instruments Sales Office/Distributors for availability and specifications.
- The maximum power dissipation must be derated at elevated temperatures and is dictated by T_{Jmax} (maximum junction temperature), $R_{\theta JA}$ (junction-to-ambient thermal resistance), and T_A (ambient temperature). The maximum allowable power dissipation at any temperature is $P_{Dmax} = (T_{Jmax} - T_A)/R_{\theta JA}$ or the number given in the *Absolute Maximum Ratings*, whichever is lower. The typical thermal resistance ($R_{\theta JA}$) when soldered to a printed circuit board is approximately 181.2°C/W for the DBV0005A package.

6.2 ESD Ratings

		VALUE	UNIT
$V_{(ESD)}$ Electrostatic discharge	Human-body model (HBM), per ANSI/ESDA/JEDEC JS-001 ⁽¹⁾	±2000	V
	Charged-device model (CDM), per JEDEC specification JESD22-C101 ⁽²⁾	±500	

- JEDEC document JEP155 states that 500-V HBM allows safe manufacturing with a standard ESD control process.
- JEDEC document JEP157 states that 250-V CDM allows safe manufacturing with a standard ESD control process.

6.3 Recommended Operating Conditions

 over operating free-air temperature range (unless otherwise noted) ⁽¹⁾⁽²⁾

	MIN	NOM	MAX	UNIT
Ambient temperature	-40		85	°C
Junction temperature	-40		125	
Output current			15	mA

- Stresses beyond those listed under *Absolute Maximum Ratings* may cause permanent damage to the device. These are stress ratings only, which do not imply functional operation of the device at these or any other conditions beyond those indicated under *Recommended Operating Conditions*. Exposure to absolute-maximum-rated conditions for extended periods may affect device reliability.
- The maximum power dissipation must be derated at elevated temperatures and is dictated by T_{Jmax} (maximum junction temperature), $R_{\theta JA}$ (junction to ambient thermal resistance), and T_A (ambient temperature). The maximum allowable power dissipation at any temperature is $P_{Dmax} = (T_{Jmax} - T_A)/R_{\theta JA}$ or the number given in the *Absolute Maximum Ratings*, whichever is lower. The typical thermal resistance ($R_{\theta JA}$) when soldered to a printed circuit board is approximately 181.2°C/W for the DBV0005A package.

6.4 Thermal Information

THERMAL METRIC ⁽¹⁾		LM3420	UNIT
		SOT-23 (DBV)	
		5 PINS	
$R_{\theta JA}$	Junction-to-ambient thermal resistance	181.2	°C/W
$R_{\theta JC(top)}$	Junction-to-case (top) thermal resistance	91.2	
$R_{\theta JB}$	Junction-to-board thermal resistance	38.2	
Ψ_{JT}	Junction-to-top characterization parameter	5.3	
Ψ_{JB}	Junction-to-board characterization parameter	37.7	

- For more information about traditional and new thermal metrics, see the *IC Package Thermal Metrics* application report, [SPRA953](#).

6.5 LM3420 Electrical Characteristics

Unless otherwise specified, specifications apply over full operating temperature range and $V_{IN} = V_{REG}$, $V_{OUT} = 1.5\text{ V}$.

PARAMETER		TEST CONDITIONS	MIN ⁽¹⁾	TYP ⁽²⁾	MAX ⁽¹⁾	UNIT
V_{REG}	Regulation voltage	$I_{OUT} = 1\text{ mA}$, $T_J = 25^\circ\text{C}$	8.316	8.4	8.484	V
		$I_{OUT} = 1\text{ mA}$	8.232	8.4	8.568	
	Regulation voltage tolerance	$I_{OUT} = 1\text{ mA}$, $T_J = 25^\circ\text{C}$	-1%		1%	
		$I_{OUT} = 1\text{ mA}$	-2%		2%	
I_Q	Quiescent current	$I_{OUT} = 1\text{ mA}$, $T_J = 25^\circ\text{C}$		85	125	μA
		$I_{OUT} = 1\text{ mA}$		85	150	
G_m	Transconductance $\Delta I_{OUT}/\Delta V_{REG}$	$20\ \mu\text{A} \leq I_{OUT} \leq 1\text{ mA}$, $V_{OUT} = 6\text{ V}$ $T_J = 25^\circ\text{C}$	1	3.3		mA/mV
		$20\ \mu\text{A} \leq I_{OUT} \leq 1\text{ mA}$, $V_{OUT} = 6\text{ V}$	0.50	3.3		
		$1\text{ mA} \leq I_{OUT} \leq 15\text{ mA}$, $V_{OUT} = 6\text{ V}$	2.5	6		
		$1\text{ mA} \leq I_{OUT} \leq 15\text{ mA}$, $V_{OUT} = 6\text{ V}$	1.4	6		
A_V	Voltage gain $\Delta V_{OUT}/\Delta V_{REG}$	$1\text{ V} \leq V_{OUT} \leq V_{REG} - 1.2\text{ V}$, $R_L = 470\ \Omega$ ⁽³⁾ $T_J = 25^\circ\text{C}$	450	1000		V/V
		$1\text{ V} \leq V_{OUT} \leq V_{REG} - 1.3\text{ V}$, $R_L = 470\ \Omega$	200	1000		
		$1\text{ V} \leq V_{OUT} \leq V_{REG} - 1.2\text{ V}$, $R_L = 5\text{ k}\Omega$ ⁽³⁾ $T_J = 25^\circ\text{C}$	1000	3500		V/V
		$1\text{ V} \leq V_{OUT} \leq V_{REG} - 1.3\text{ V}$, $R_L = 5\text{ k}\Omega$	700	3500		
V_{SAT}	Output saturation ⁽⁴⁾	$V_{IN} = V_{REG} + 100\text{ mV}$ $T_J = 25^\circ\text{C}$		1	1.2	V
		$V_{IN} = V_{REG} + 100\text{ mV}$		1	1.3	
I_L	Output leakage current	$V_{IN} = V_{REG} - 100\text{ mV}$, $V_{OUT} = 0\text{ V}$ $T_J = 25^\circ\text{C}$		0.1	0.5	μA
		$V_{IN} = V_{REG} - 100\text{ mV}$, $V_{OUT} = 0\text{ V}$		0.1	1	
R_f	Internal feedback resistor ⁽⁵⁾	$T_J = 25^\circ\text{C}$	135	181	227	k Ω
E_n	Output noise voltage	$I_{OUT} = 1\text{ mA}$, $10\text{ Hz} \leq f \leq 10\text{ kHz}$		140		μV_{RMS}

- (1) Limits are 100% production tested at 25°C. Limits over the operating temperature range are specified through correlation using Statistical Quality Control (SQC) methods. The limits are used to calculate Averaging Outgoing Quality Level (AOQL).
- (2) Typical numbers are at 25°C and represent the most likely parametric norm.
- (3) Actual test is done using equivalent current sink instead of a resistor load.
- (4) $V_{SAT} = V(IN) - V_{OUT}$, when the voltage at the IN pin is forced 100 mV above the nominal regulating voltage (V_{REG}).
- (5) See [Application and Implementation](#) and [Typical Characteristics](#) sections for information on this resistor.

6.6 LM3420A Electrical Characteristics

Unless otherwise specified, specifications apply over full operating temperature range and $V_{IN} = V_{REG}$, $V_{OUT} = 1.5\text{ V}$.

PARAMETER		TEST CONDITIONS	MIN ⁽¹⁾	TYP ⁽²⁾	MAX ⁽¹⁾	UNIT
V_{REG}	Regulation voltage	$I_{OUT} = 1\text{ mA}$, $T_J = 25^\circ\text{C}$	8.358	8.4	8.442	V
		$I_{OUT} = 1\text{ mA}$	8.316	8.4	8.484	
	Regulation voltage tolerance	$I_{OUT} = 1\text{ mA}$, $T_J = 25^\circ\text{C}$	-0.5%		0.5%	
		$I_{OUT} = 1\text{ mA}$	-1%		1%	
I_Q	Quiescent current	$I_{OUT} = 1\text{ mA}$, $T_J = 25^\circ\text{C}$		85	110	μA
		$I_{OUT} = 1\text{ mA}$		85	115	
G_m	Transconductance $\Delta I_{OUT}/\Delta V_{REG}$	$20\ \mu\text{A} \leq I_{OUT} \leq 1\text{ mA}$, $V_{OUT} = 6\text{ V}$ $T_J = 25^\circ\text{C}$	1.3	3.3		mA/mV
		$20\ \mu\text{A} \leq I_{OUT} \leq 1\text{ mA}$, $V_{OUT} = 6\text{ V}$	0.75	3.3		
		$1\text{ mA} \leq I_{OUT} \leq 15\text{ mA}$, $V_{OUT} = 6\text{ V}$	3	6		
		$1\text{ mA} \leq I_{OUT} \leq 15\text{ mA}$, $V_{OUT} = 6\text{ V}$	1.5	6		
A_V	Voltage gain $\Delta V_{OUT}/\Delta V_{REG}$	$1\text{ V} \leq V_{OUT} \leq V_{REG} - 1.2\text{ V}$, $R_L = 470\ \Omega$ ⁽³⁾ $T_J = 25^\circ\text{C}$	550	1000		V/V
		$1\text{ V} \leq V_{OUT} \leq V_{REG} - 1.3\text{ V}$, $R_L = 470\ \Omega$	250	1000		
		$1\text{ V} \leq V_{OUT} \leq V_{REG} - 1.2\text{ V}$, $R_L = 5\text{ k}\Omega$ ⁽³⁾ $T_J = 25^\circ\text{C}$	1500	3500		V/V
		$1\text{ V} \leq V_{OUT} \leq V_{REG} - 1.3\text{ V}$, $R_L = 5\text{ k}\Omega$	900	3500		
V_{SAT}	Output saturation ⁽⁴⁾	$V_{IN} = V_{REG} + 100\text{ mV}$ $T_J = 25^\circ\text{C}$		1	1.2	V
		$V_{IN} = V_{REG} + 100\text{ mV}$		1	1.3	
I_L	Output leakage current	$V_{IN} = V_{REG} - 100\text{ mV}$, $V_{OUT} = 0\text{ V}$ $T_J = 25^\circ\text{C}$		0.1	0.5	μA
		$V_{IN} = V_{REG} - 100\text{ mV}$, $V_{OUT} = 0\text{ V}$		0.1	1	
R_f	Internal feedback resistor ⁽⁵⁾	$T_J = 25^\circ\text{C}$	135	181	227	k Ω
E_n	Output noise voltage	$I_{OUT} = 1\text{ mA}$, $10\text{ Hz} \leq f \leq 10\text{ kHz}$	140			μV_{RMS}

(1) Limits are 100% production tested at 25°C. Limits over the operating temperature range are specified through correlation using Statistical Quality Control (SQC) methods. The limits are used to calculate Averaging Outgoing Quality Level (AOQL).

(2) Typical numbers are at 25°C and represent the most likely parametric norm.

(3) Actual test is done using equivalent current sink instead of a resistor load.

(4) $V_{SAT} = V_{IN} - V_{OUT}$, when the voltage at the IN pin is forced 100 mV above the nominal regulating voltage (V_{REG}).

(5) See [Application and Implementation](#) and [Typical Characteristics](#) sections for information on this resistor.

6.7 Typical Characteristics

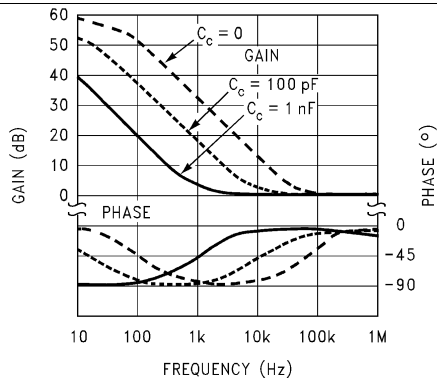

Figure 1. Bode Plot

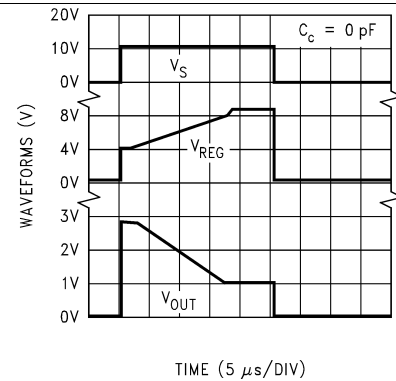

Figure 2. Response Time

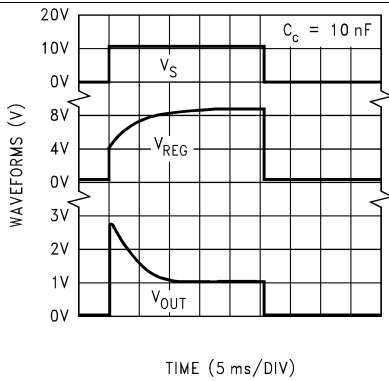

Figure 3. Response Time

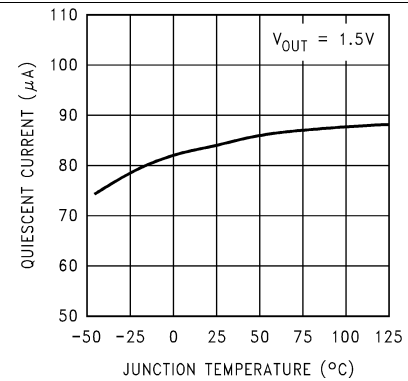

Figure 4. Quiescent Current

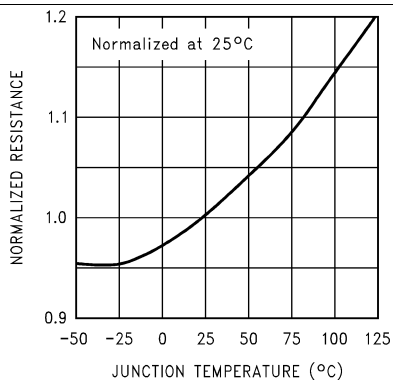

Figure 5. Internal Feedback Resistor (Rf) Tempco

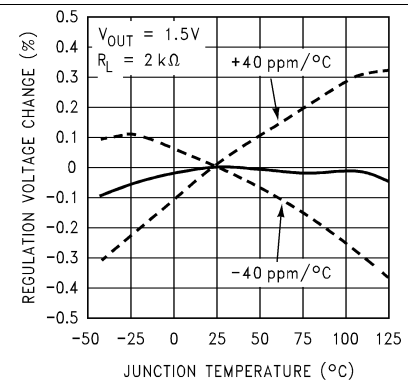

Figure 6. Normalized Temperature Drift

Typical Characteristics (continued)

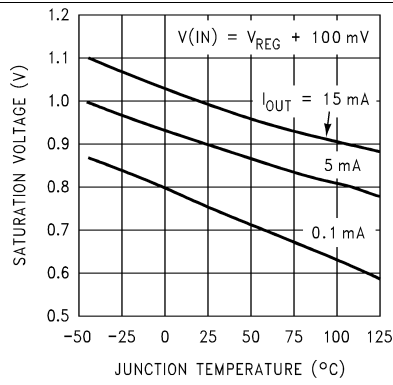

Figure 7. Output Saturation Voltage (V_{SAT})

7 Parameter Measurement Information

7.1 Test Circuits

The test circuits shown in [Figure 8](#), [Figure 9](#) and [Figure 10](#) can be used to measure and verify various LM3420 parameters. Test conditions are set by forcing the appropriate voltage at the V_{OUT} Set test point and selecting the appropriate R_L or I_{OUT} as specified in [LM3420 Electrical Characteristics](#). Use a DVM at the “measure” test points to read the data.

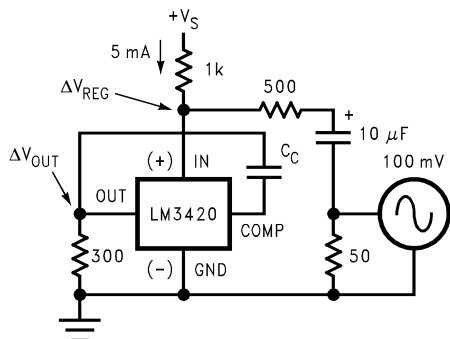

Figure 8. Circuit Used For Bode Plots

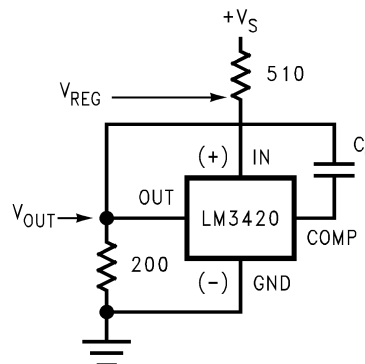

Figure 9. Circuit Used For Response Time

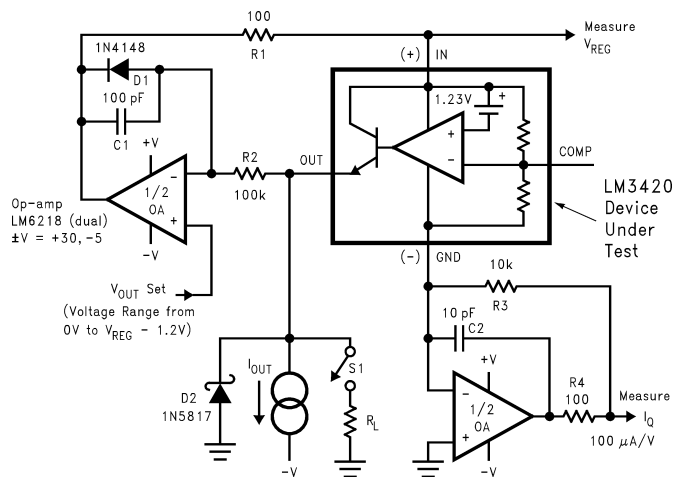

Figure 10. LM3420 Test Circuit

8 Detailed Description

8.1 Overview

The LM3420 is a shunt regulator specifically designed to be the reference and control section in an overall feedback loop of a lithium-ion battery charger. The regulated output voltage is sensed between the IN pin and GROUND pin of the LM3420. If the voltage at the IN pin is less than the LM3420 regulating voltage (V_{REG}), the OUT pin sources no current. As the voltage at the IN pin approaches the V_{REG} voltage, the OUT pin begins sourcing current. This current is then used to drive a feedback device (opto-coupler), or a power device (linear regulator, switching regulator, etc.), which servos the output voltage to be the same value as V_{REG} .

In some applications, (even under normal operating conditions) the voltage on the IN pin can be forced above the V_{REG} voltage. In these instances, the maximum voltage applied to the IN pin should not exceed 20 V. In addition, an external resistor may be required on the OUT pin to limit the maximum current to 20 mA.

8.2 Functional Block Diagram

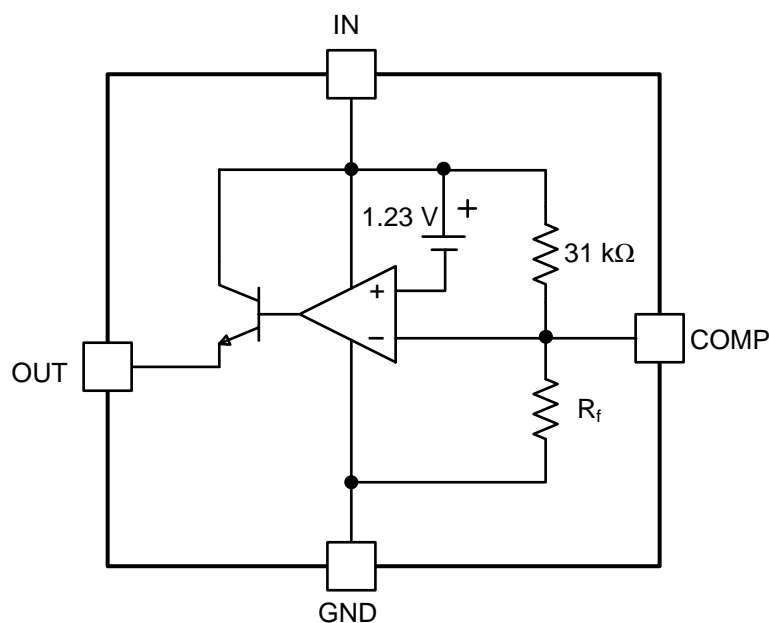

8.3 Feature Description

8.3.1 Compensation

The inverting input of the error amplifier is brought out to allow overall closed-loop compensation. In many of the applications circuits shown here, compensation is provided by a single capacitor (C_C) connected from the compensation pin to the out pin of the LM3420. The capacitor values shown in the schematics are adequate under most conditions, but they can be increased or decreased depending on the desired loop response. Applying a load pulse to the output of a regulator circuit and observing the resultant output voltage response is an easy method of determining the stability of the control loop.

Analyzing more complex feedback loops requires additional information.

The formula for AC gain at a frequency (f) is shown in [Equation 1](#):

$$\text{Gain}(f) = 1 + \frac{Z_f(f)}{R_f}$$

$$\text{where } Z_f(f) = \frac{1}{j \cdot 2\pi \cdot f \cdot C_C}$$

and where

Feature Description (continued)

- $R_f \approx 181 \text{ k}\Omega$ (1)

The resistor (R_f) in the formula is an internal resistor located on the die. Since this resistor value affects the phase margin, the worst case maximum and minimum values are important when analyzing closed loop stability. The minimum and maximum room temperature values of this resistor are specified in the [LM3420 Electrical Characteristics](#) section of this data sheet, and a curve showing the temperature coefficient is shown in the curves section. Minimum values of R_f result in lower phase margins.

8.3.2 V_{REG} External Voltage Trim

The regulation voltage (V_{REG}) of the LM3420 can be externally trimmed by adding a single resistor from the COMP pin to the +IN pin or from the COMP pin to the GND pin, depending on the desired trim direction. Trim adjustments up to $\pm 10\%$ of V_{REG} can be realized, with only a small increase in the temperature coefficient. (See temperature coefficient curve shown in [Figure 11.](#))

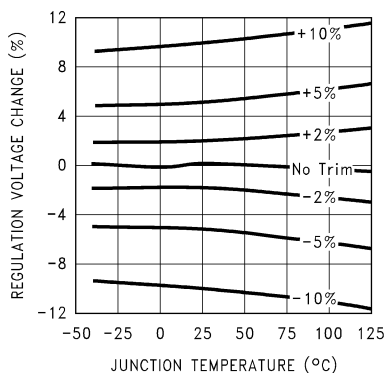

Figure 11. Normalized Temperature Drift With Output Externally Trimmed

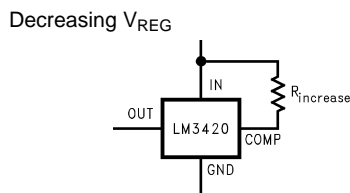

Figure 12. Increasing V_{REG}

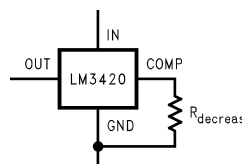

Figure 13. Changing V_{REG}

Formula for selecting trim resistor values is shown in [Equation 2](#) and [Equation 3](#), based on the percent of increase (%incr) or percent of decrease (%decr) of the output voltage from the nominal voltage.

$$R_{\text{increase}} = 26 \times 10^5 / \% \text{incr} \quad (2)$$

$$R_{\text{decrease}} = (154 \times 10^5 / \% \text{decr}) - 181 \times 10^3 \quad (3)$$

8.4 Device Functional Modes

8.4.1 Operation as Control Section

The LM3420 is monolithic integrated circuits, which is suitable for charging and end-of-charge control for Lithium-Ion rechargeable batteries. In this application, LM3420 is the reference and control section in the overall feedback loop. The regulated voltage is sensed between the IN pin and GND pin. If the voltage at the IN pin is less than the regulating voltage (V_{REG}), the OUT pin sources no current. As the voltage at the IN pin approaches the V_{REG} , the OUT pin begins sourcing current, which can drive a feedback device or a power device.

9 Application and Implementation

NOTE

Information in the following applications sections is not part of the TI component specification, and TI does not warrant its accuracy or completeness. TI's customers are responsible for determining suitability of components for their purposes. Customers should validate and test their design implementation to confirm system functionality.

9.1 Application Information

The LM3420 regulator/driver provides the reference and feedback drive functions for a Lithium-Ion battery charger. It can be used in many different charger configurations using both linear and switching topologies to provide the precision needed for charging lithium-ion batteries safely and efficiently. Output voltage tolerances better than 0.5% are possible without using trim pots or precision resistors. The circuits shown are designed for 2-cell operation, but they can readily be changed for either 1-, 3-, or 4-cell charging applications.

One item to keep in mind when designing with the LM3420 is that there are parasitic diodes present. In some designs, under special electrical conditions, unwanted currents may flow. Parasitic diodes exist from OUT to IN, as well as from GROUND to IN. In both instances the diode arrow is pointed toward the IN pin.

9.2 Typical Application: Constant Current/Constant Voltage Li-Ion Battery Charger

The circuit shown in Figure 14 performs constant-current, constant-voltage charging of two Li-Ion cells. At the beginning of the charge cycle, when the battery voltage is less than 8.4 V, the LM3420 sources no current from the OUT pin, keeping Q2 off, thus allowing the LM317 Adjustable voltage regulator to operate as a constant-current source. (The LM317 is rated for currents up to 1.5 A, and the LM350 and LM338 can be used for higher currents.) The LM317 forces a constant 1.25 V across R_{LIM}, thus generating a constant current of

$$I_{LIM} = 1.25V/R_{LIM} \tag{4}$$

Transistor Q1 provides a disconnect between the battery and the LM3420 when the input voltage is removed. This prevents the 85-μA quiescent current of the LM3420 from eventually discharging the battery. In this application Q1 is used as a low offset saturated switch, with the majority of the base drive current flowing through the collector and crossing over to the emitter as the battery becomes fully charged. It provides a very low collector to emitter saturation voltage (approximately 5 mV). Diode D1 is also used to prevent the battery current from flowing through the LM317 regulator from the output to the input when the DC input voltage is removed.

As the battery charges, its voltage begins to rise, and is sensed at the IN pin of the LM3420. Once the battery voltage reaches 8.4 V, the LM3420 begins to regulate and starts sourcing current to the base of Q2. Transistor Q2 begins controlling the ADJ pin of the LM317 which begins to regulate the voltage across the battery and the constant voltage portion of the charging cycle starts. Once the charger is in the constant voltage mode, the charger maintains a regulated 8.4 V across the battery and the charging current is dependent on the state of charge of the battery. As the cells approach a fully charged condition, the charge current falls to a very low value.

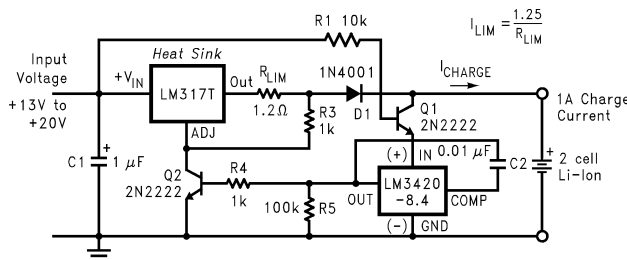

Figure 14. Constant Current/Constant Voltage Li-Ion Battery Charger

Typical Application: Constant Current/Constant Voltage Li-Ion Battery Charger (continued)

9.2.1 Design Requirements

DESIGN PARAMETER	EXAMPLE VALUE
Input voltage	13 V - 20 V
Output voltage	8.4 V
Output current	1 A

9.2.2 Detailed Design Procedure

9.2.2.1 Compensation Capacitor

The capacitor between OUT pin and COMP pin can be increase or decreased depending on the desired loop response. [Functional Block Diagram](#) can be referred as different capacitance selection. In this case, 0.01- μ F capacitor is used.

9.2.3 Application Curve

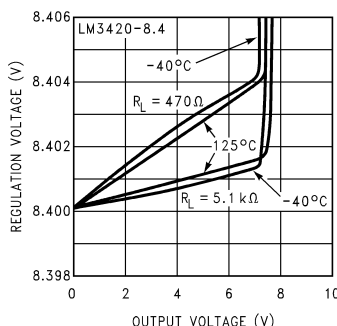

Figure 15. Regulation Voltage vs Output Voltage and Load Resistance

9.2.4 Other Application Circuits

NOTE

Although the application circuits shown here have been built and tested, they should be thoroughly evaluated with the same type of battery the charger will eventually be used with.

Different battery manufacturers may use a slightly different battery chemistry which may require different charging characteristics. Always consult the battery manufacturer for information on charging specifications and battery details, and always observe the manufacturers precautions when using their batteries. Avoid overcharging or shorting Lithium-Ion batteries.

9.2.4.1 Low Dropout Constant Current/Constant Voltage 2-Cell Charger

Figure 16 shows a Li-Ion battery charger that features a dropout voltage of less than one volt. This charger is a constant-current, constant-voltage charger (it operates in constant-current mode at the beginning of the charge cycle and switches over to a constant-voltage mode near the end of the charging cycle). The circuit consists of two basic feedback loops. The first loop controls the constant charge current delivered to the battery, and the second determines the final voltage across the battery.

With a discharged battery connected to the charger, (battery voltage is less than 8.4 V) the circuit begins the charge cycle with a constant charge current. The value of this current is set by using the reference section of the LM10C to force 200 mV across R7 thus causing approximately 100 μ A of emitter current to flow through Q1, and approximately 1 mA of emitter current to flow through Q2. The collector current of Q1 is also approximately 100 μ A, and this current flows through R2 developing 50 mV across it. This 50 mV is used as a reference to develop the constant charge current through the current sense resistor R1.

The constant current feedback loop operates as follows. Initially, the emitter and collector current of Q2 are both approximately 1 mA, thus providing gate drive to the MOSFET Q3, turning it on. The output of the LM301A op-amp is low. As the Q3 current reaches 1 A, the voltage across R1 approaches 50 mV, thus canceling the 50-mV drop across R2, and causing the op-amp's output to start going positive, and begin sourcing current into R8. As more current is forced into R8 from the op-amp, the collector current of Q2 is reduced by the same amount, which decreases the gate drive to Q3, to maintain a constant 50 mV across the 0.05- Ω current sensing resistor, thus maintaining a constant 1 A of charge current.

The current limit loop is stabilized by compensating the LM301A with C1 (the standard frequency compensation used with this op-amp) and C2, which is additional compensation needed when D3 is forward biased. This helps speed up the response time during the reverse bias of D3. When the LM301A output is low, diode D3 reverse biases and prevents the op-amp from pulling more current through the emitter of Q2. This is important when the battery voltage reaches 8.4 V, and the 1A charge current is no longer needed. Resistor R5 isolates the LM301A feedback node at the emitter of Q2.

The battery voltage is sensed and buffered by the op-amp section of the LM10C, connected as a voltage follower driving the LM3420. When the battery voltage reaches 8.4 V, the LM3420 begins regulating by sourcing current into R8, which controls the collector current of Q2, which in turn reduces the gate voltage of Q3 and becomes a constant voltage regulator for charging the battery. Resistor R6 isolates the LM3420 from the common feedback node at the emitter of Q2. If R5 and R6 are omitted, oscillations could occur during the transition from the constant-current to the constant-voltage mode. D2 and the PNP transistor input stage of the LM10C disconnects the battery from the charger circuit when the input supply voltage is removed to prevent the battery from discharging.

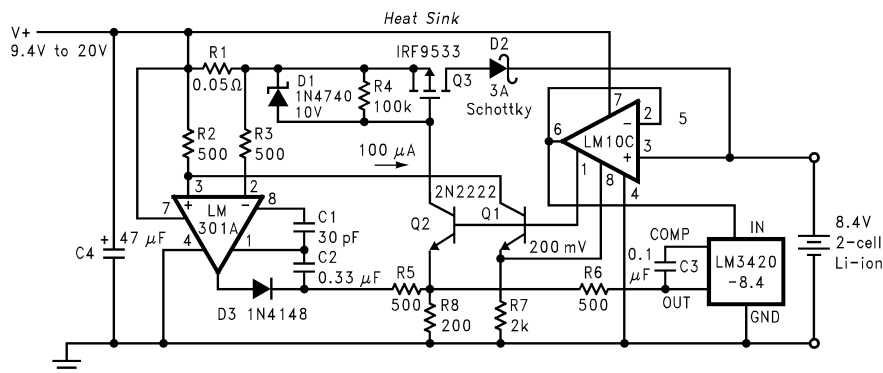

Figure 16. Low Dropout Constant Current/Constant Voltage 2-Cell Charger

9.2.4.2 High-Efficiency Switching Regulator Constant Current/Constant Voltage 2-Cell Charger

A switching regulator, constant-current, constant-voltage two-cell Li-Ion battery charging circuit is shown in [Figure 17](#). This circuit provides much better efficiency, especially over a wide input voltage range than the linear topologies. For a 1-A charger an LM2575-ADJ. switching regulator IC is used in a standard buck topology. For other currents, or other packages, other members of the SIMPLE SWITCHER[®] buck regulator family may be used.

Circuit operation is as follows. With a discharged battery connected to the charger, the circuit operates as a constant current source. The constant-current portion of the charger is formed by the loop consisting of one half of the LM358 op amp along with gain setting resistors R3 and R4, current sensing resistor R5, and the feedback reference voltage of 1.23 V. Initially the LM358 output is low causing the output of the LM2575-ADJ to rise thus causing some charging current to flow into the battery. When the current reaches 1 A, it is sensed by resistor R5 (50 m Ω), and produces 50 mV. This 50 mV is amplified by the op-amps gain of 25 to produce 1.23V, which is applied to the feedback pin of the LM2575-ADJ to satisfy the feedback loop.

Once the battery voltage reaches 8.4 V, the LM3420 takes over and begins to control the feedback pin of the LM2575-ADJ. The LM3420 now regulates the voltage across the battery, and the charger becomes a constant-voltage charger. Loop compensation network R6 and C3 ensure stable operation of the charger circuit under both constant-current and constant-voltage conditions. If the input supply voltage is removed, diode D2 and the PNP input stage of the LM358 become reversed biased and disconnects the battery to ensure that the battery is not discharged. Diode D3 reverse biases to prevent the op-amp from sinking current when the charger changes to constant voltage mode.

The minimum supply voltage for this charger is approximately 11 V, and the maximum is around 30 V (limited by the 32-V maximum operating voltage of the LM358). If another op-amp is substituted for the LM358, make sure that the input common-mode range of the op-amp extends down to ground so that it can accurately sense 50 mV. R1 is included to provide a minimum load for the switching regulator to assure that switch leakage current does not cause the output to rise when the battery is removed.

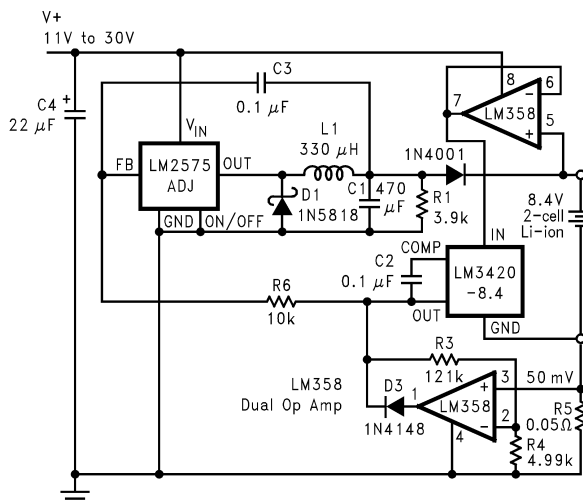

Figure 17. High-Efficiency Switching Regulator Constant Current/Constant Voltage 2-Cell Charger

9.2.4.3 Low Dropout Constant Current/Constant Voltage Li-Ion Battery Charger

The circuit in Figure 18 is very similar to Figure 17, except the switching regulator has been replaced with a low dropout linear regulator, allowing the input voltage to be as low as 10 V. The constant current and constant voltage control loops are the same as the previous circuit. Diode D2 has been changed to a Schottky diode to provide a reduction in the overall dropout voltage of this circuit, but Schottky diodes typically have higher leakage currents than a standard silicon diode. This leakage current could discharge the battery if the input voltage is removed for an extended period of time.

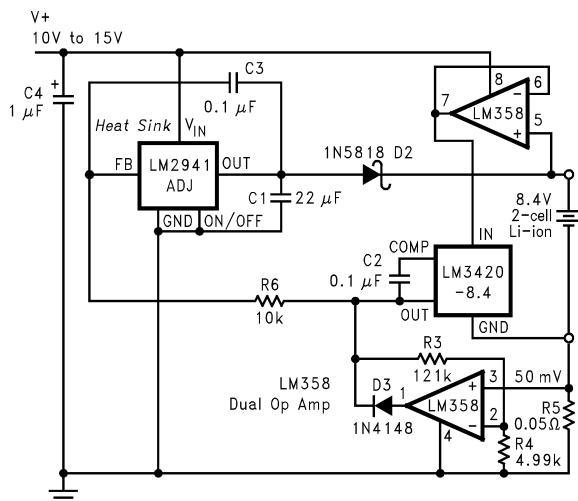

Figure 18. Low Dropout Constant Current/Constant Voltage Li-Ion Battery Charger

9.2.4.4 High-Efficiency Switching Charger With High Side Current Sensing

Another variation of a constant current/constant voltage switch mode charger is shown in Figure 19. The basic feedback loops for current and voltage are similar to the previous circuits. This circuit has the current sensing resistor, for the constant current part of the feedback loop, on the positive side of the battery, thus allowing a common ground between the input supply and the battery. Also, the LMC7101 op-amp is available in a very small SOT-23-5 package thus allowing a very compact PC board design. Diode D4 prevents the battery from discharging through the charger circuitry if the input voltage is removed, although the quiescent current of the LM3420 is still present (approximately 85 μ A).

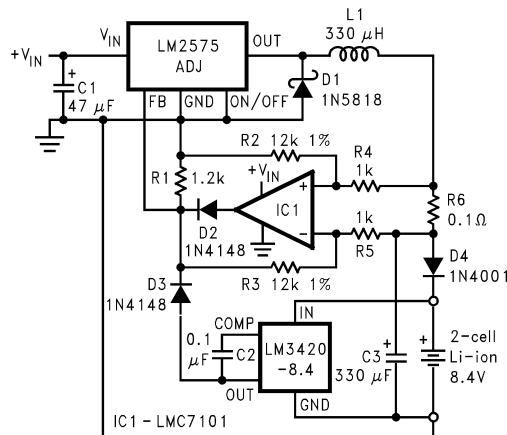

Figure 19. High Efficiency Switching Charger With High Side Current Sensing

9.2.4.5 Fast-Pulsed Constant Current 2-Cell Charger

A rapid charge Lithium-Ion battery charging circuit is shown in Figure 20. This configuration uses a switching regulator to deliver the charging current in a series of constant current pulses. At the beginning of the charge cycle (constant-current mode), this circuit performs identically to the previous LM2575 charger by charging the battery at a constant current of 1 A. As the battery voltage reaches 8.4 V, this charger changes from a constant continuous current of 1 A to a 5-second pulsed 1 A. This allows the total battery charge time to be reduced considerably. This is different from the other charging circuits that switch from a constant current charge to a constant voltage charge once the battery voltage reaches 8.4 V. After charging the battery with 1 A for 5 seconds, the charge stops, and the battery voltage begins to drop. When it drops below 8.4 V, the LM555 timer again starts the timing cycle and charges the battery with 1 A for another 5 seconds. This cycling continues with a constant 5-second charge time, and a variable off time. In this manner, the battery is charged with 1 A for 5 seconds, followed by an off period (determined by the battery's state of charge), setting up a periodic 1-A charge current. The off time is determined by how long it takes the battery voltage to decrease back down to 8.4 V. When the battery first reaches 8.4 V, the off time is very short (1 ms or less), but when the battery approaches full charge, the off time begins increasing to tens of seconds, then minutes, and eventually hours.

The constant-current loop for this charger and the method used for programming the 1-A constant current is identical to the previous LM2575-ADJ charger. In this circuit, a second LM3420-8.4 has its V_{REG} increased by approximately 400 mV (via R2), and is used to limit the output voltage of the charger to 8.8V in the event of a bad battery connection, or the battery is removed or possibly damaged.

The LM555 timer is connected as a one-shot, and is used to provide the 5-second charging pulses. As long as the battery voltage is less than the 8.4 V, the output of IC3 is held low, and the LM555 one-shot never fires (the output of the LM555 is held high) and the one-shot has no effect on the charger. Once the battery voltage exceeds the 8.4-V regulation voltage of IC3, the trigger pin of the LM555 is pulled high, enabling the one shot to begin timing. The charge current is now pulsed into the battery at a 5-second rate, with the off time determined by the battery's state of charge. The LM555 output goes high for 5 seconds (pulling down the collector of Q1) which allows the 1-A constant-current loop to control the circuit.

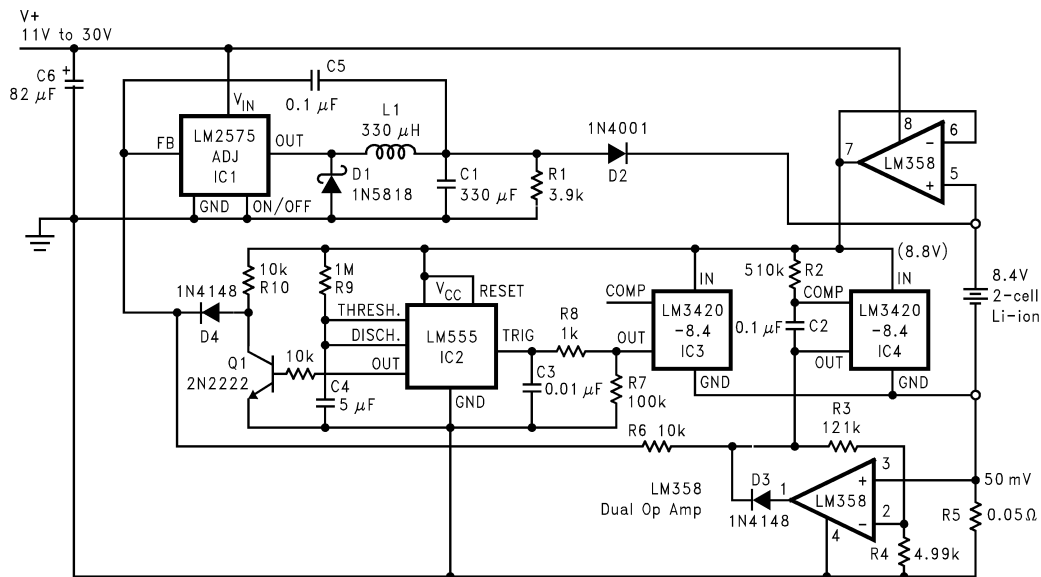

Figure 20. (Fast) Pulsed Constant Current 2-Cell Charger

9.2.4.6 MOSFET Low Dropout Charger

Figure 21 shows a low dropout constant voltage charger using a MOSFET as the pass element, but this circuit does not include current limiting. This circuit uses Q3 and a Schottky diode to isolate the battery from the charging circuitry when the input voltage is removed, to prevent the battery from discharging. Q2 should be a high-current (0.2-Ω) FET, while Q3 can be a low-current (2-Ω) device.

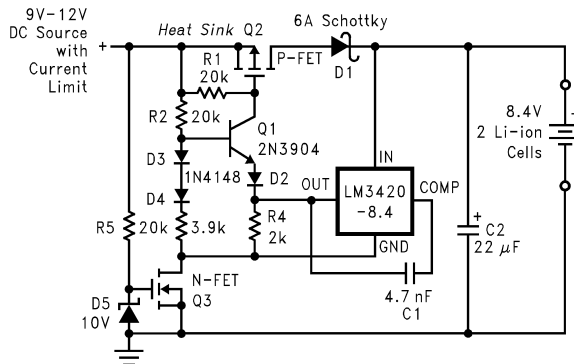

Figure 21. MOSFET Low Dropout Charger

10 Power Supply Recommendations

The LM3420 is designed to operate from up to 20-V input voltage supply. This input supply must be well regulated. If the input supply is noisy, additional input capacitors with low ESR can help to improve the output noise performance.

11 Layout

11.1 Layout Guidelines

For best overall performance, place all the circuit components on the same side of the circuit board and as near as practical to the respective pin connections. Place ground return connections to the input and output capacitor, and to the regulator ground pin as close to each other as possible, connected by a wide, component-side, copper surface. The use of vias and long traces to create circuit connections is strongly discouraged and negatively affects system performance. This grounding and layout scheme minimizes inductive parasitic, and thereby reduces load-current transients, minimizes noise, and increases circuit stability. A ground reference plane is also recommended and is either embedded in the PCB itself or located on the bottom side of the PCB opposite the components. This reference plane serves to assure accuracy of the output voltage, shield noise, and behaves similar to a thermal plane to spread heat from the device. In most applications, this ground plane is necessary to meet thermal requirements.

11.2 Layout Example

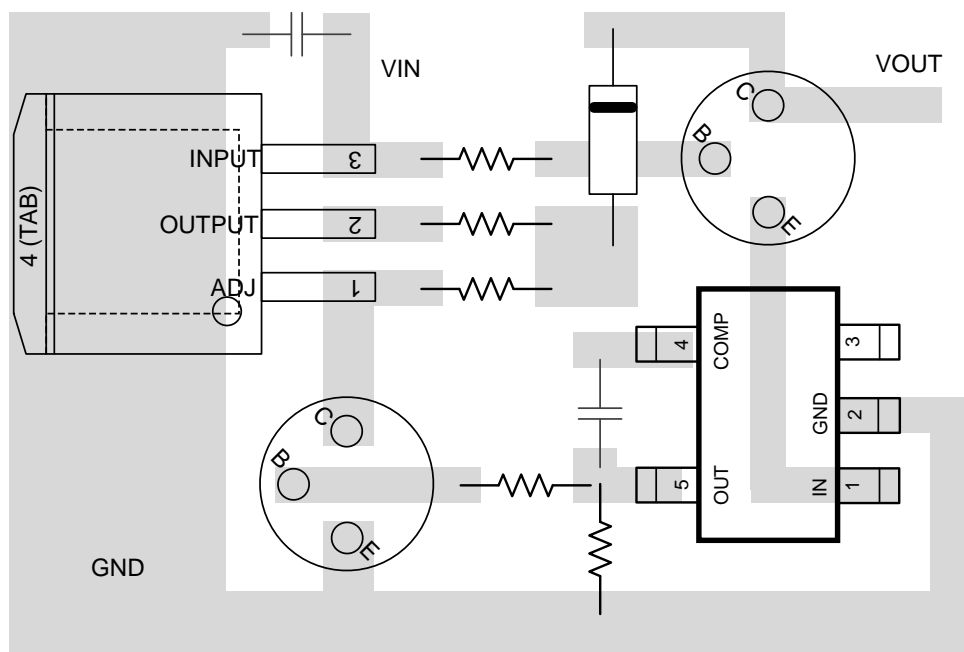

Figure 22. LM3420 Layout

12 Device and Documentation Support

12.1 Trademarks

SIMPLE SWITCHER is a registered trademark of Texas Instruments. All other trademarks are the property of their respective owners.

12.2 Electrostatic Discharge Caution



These devices have limited built-in ESD protection. The leads should be shorted together or the device placed in conductive foam during storage or handling to prevent electrostatic damage to the MOS gates.

12.3 Glossary

[SLYZ022](#) — *TI Glossary*.

This glossary lists and explains terms, acronyms, and definitions.

13 Mechanical, Packaging, and Orderable Information

The following pages include mechanical, packaging, and orderable information. This information is the most current data available for the designated devices. This data is subject to change without notice and revision of this document. For browser-based versions of this data sheet, refer to the left-hand navigation.

PACKAGING INFORMATION

Orderable Device	Status (1)	Package Type	Package Drawing	Pins	Package Qty	Eco Plan (2)	Lead/Ball Finish (6)	MSL Peak Temp (3)	Op Temp (°C)	Device Marking (4/5)	Samples
LM3420AM5-8.4/NOPB	NRND	SOT-23	DBV	5	1000	Green (RoHS & no Sb/Br)	CU SN	Level-1-260C-UNLIM	-40 to 125	D03A	
LM3420M5X-8.4/NOPB	NRND	SOT-23	DBV	5	3000	Green (RoHS & no Sb/Br)	CU SN	Level-1-260C-UNLIM	-40 to 125	D03B	

(1) The marketing status values are defined as follows:

ACTIVE: Product device recommended for new designs.

LIFEBUY: TI has announced that the device will be discontinued, and a lifetime-buy period is in effect.

NRND: Not recommended for new designs. Device is in production to support existing customers, but TI does not recommend using this part in a new design.

PREVIEW: Device has been announced but is not in production. Samples may or may not be available.

OBSOLETE: TI has discontinued the production of the device.

(2) **RoHS:** TI defines "RoHS" to mean semiconductor products that are compliant with the current EU RoHS requirements for all 10 RoHS substances, including the requirement that RoHS substance do not exceed 0.1% by weight in homogeneous materials. Where designed to be soldered at high temperatures, "RoHS" products are suitable for use in specified lead-free processes. TI may reference these types of products as "Pb-Free".

RoHS Exempt: TI defines "RoHS Exempt" to mean products that contain lead but are compliant with EU RoHS pursuant to a specific EU RoHS exemption.

Green: TI defines "Green" to mean the content of Chlorine (Cl) and Bromine (Br) based flame retardants meet JS709B low halogen requirements of <=1000ppm threshold. Antimony trioxide based flame retardants must also meet the <=1000ppm threshold requirement.

(3) MSL, Peak Temp. - The Moisture Sensitivity Level rating according to the JEDEC industry standard classifications, and peak solder temperature.

(4) There may be additional marking, which relates to the logo, the lot trace code information, or the environmental category on the device.

(5) Multiple Device Markings will be inside parentheses. Only one Device Marking contained in parentheses and separated by a "~" will appear on a device. If a line is indented then it is a continuation of the previous line and the two combined represent the entire Device Marking for that device.

(6) Lead/Ball Finish - Orderable Devices may have multiple material finish options. Finish options are separated by a vertical ruled line. Lead/Ball Finish values may wrap to two lines if the finish value exceeds the maximum column width.

Important Information and Disclaimer:The information provided on this page represents TI's knowledge and belief as of the date that it is provided. TI bases its knowledge and belief on information provided by third parties, and makes no representation or warranty as to the accuracy of such information. Efforts are underway to better integrate information from third parties. TI has taken and continues to take reasonable steps to provide representative and accurate information but may not have conducted destructive testing or chemical analysis on incoming materials and chemicals. TI and TI suppliers consider certain information to be proprietary, and thus CAS numbers and other limited information may not be available for release.

In no event shall TI's liability arising out of such information exceed the total purchase price of the TI part(s) at issue in this document sold by TI to Customer on an annual basis.

TAPE AND REEL INFORMATION



QUADRANT ASSIGNMENTS FOR PIN 1 ORIENTATION IN TAPE



*All dimensions are nominal

Device	Package Type	Package Drawing	Pins	SPQ	Reel Diameter (mm)	Reel Width W1 (mm)	A0 (mm)	B0 (mm)	K0 (mm)	P1 (mm)	W (mm)	Pin1 Quadrant
LM3420AM5-8.4/NOPB	SOT-23	DBV	5	1000	178.0	8.4	3.2	3.2	1.4	4.0	8.0	Q3
LM3420M5X-8.4/NOPB	SOT-23	DBV	5	3000	178.0	8.4	3.2	3.2	1.4	4.0	8.0	Q3

TAPE AND REEL BOX DIMENSIONS

*All dimensions are nominal

Device	Package Type	Package Drawing	Pins	SPQ	Length (mm)	Width (mm)	Height (mm)
LM3420AM5-8.4/NOPB	SOT-23	DBV	5	1000	210.0	185.0	35.0
LM3420M5X-8.4/NOPB	SOT-23	DBV	5	3000	210.0	185.0	35.0

DBV0005A



PACKAGE OUTLINE

SOT-23 - 1.45 mm max height

SMALL OUTLINE TRANSISTOR

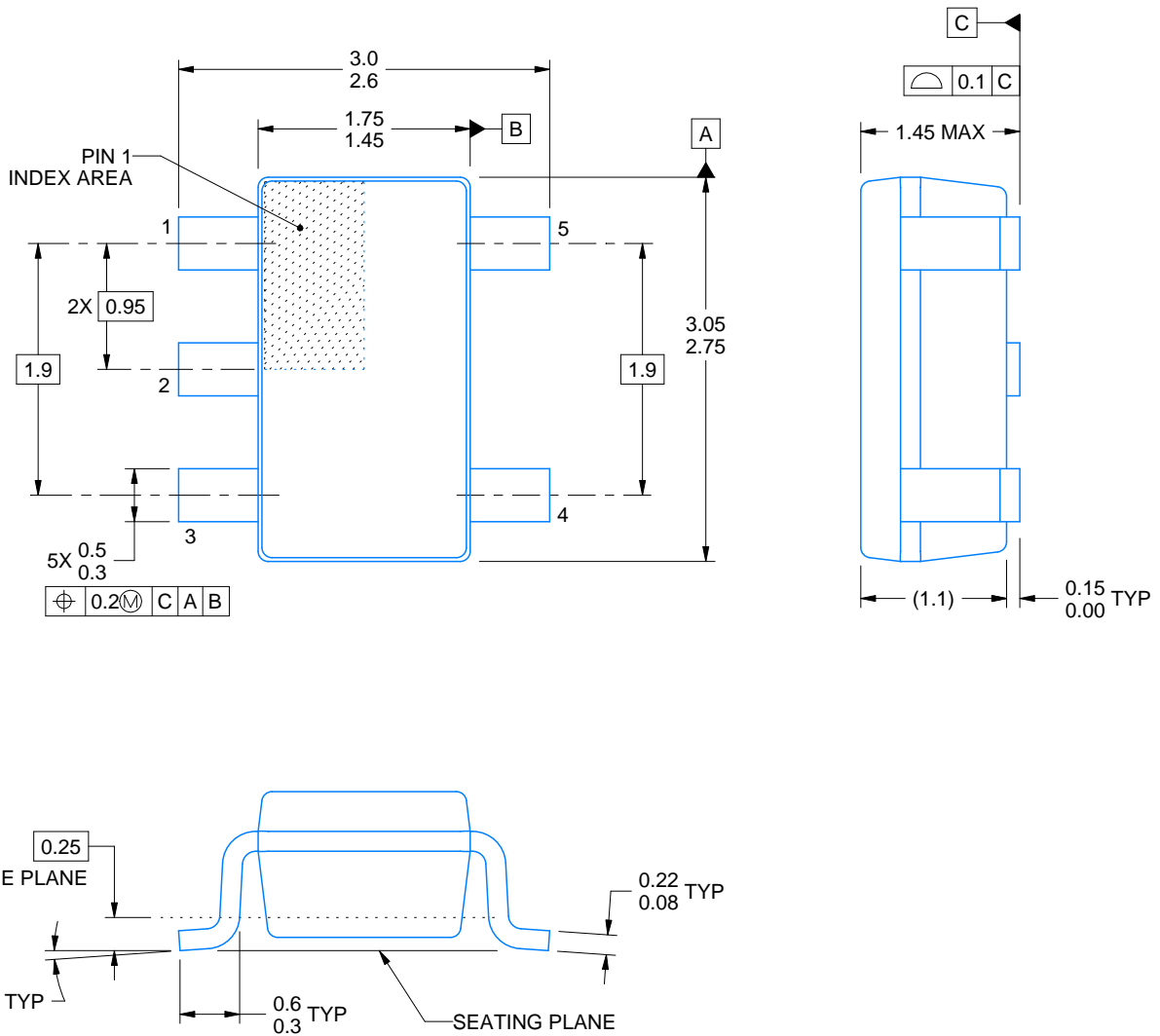

4214839/D 11/2018

NOTES:

1. All linear dimensions are in millimeters. Any dimensions in parenthesis are for reference only. Dimensioning and tolerancing per ASME Y14.5M.
2. This drawing is subject to change without notice.
3. Reference JEDEC MO-178.
4. Body dimensions do not include mold flash, protrusions, or gate burrs. Mold flash, protrusions, or gate burrs shall not exceed 0.15 mm per side.

EXAMPLE BOARD LAYOUT

DBV0005A

SOT-23 - 1.45 mm max height

SMALL OUTLINE TRANSISTOR

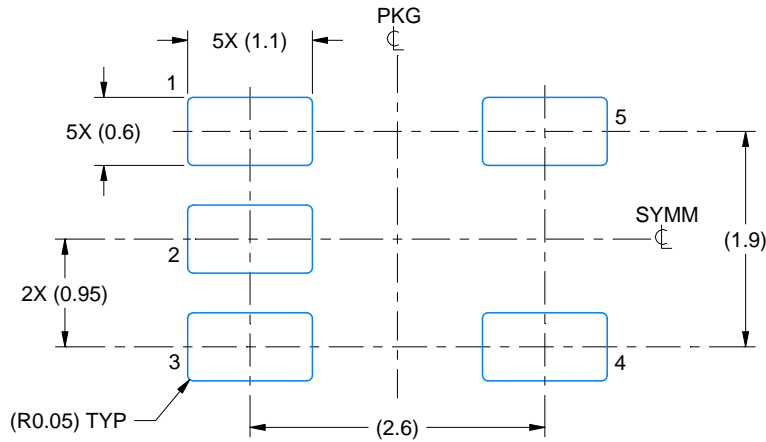

LAND PATTERN EXAMPLE
EXPOSED METAL SHOWN
SCALE:15X



SOLDER MASK DETAILS

4214839/D 11/2018

NOTES: (continued)

- 5. Publication IPC-7351 may have alternate designs.
- 6. Solder mask tolerances between and around signal pads can vary based on board fabrication site.

EXAMPLE STENCIL DESIGN

DBV0005A

SOT-23 - 1.45 mm max height

SMALL OUTLINE TRANSISTOR



SOLDER PASTE EXAMPLE
BASED ON 0.125 mm THICK STENCIL
SCALE:15X

4214839/D 11/2018

NOTES: (continued)

7. Laser cutting apertures with trapezoidal walls and rounded corners may offer better paste release. IPC-7525 may have alternate design recommendations.
8. Board assembly site may have different recommendations for stencil design.

IMPORTANT NOTICE AND DISCLAIMER

TI PROVIDES TECHNICAL AND RELIABILITY DATA (INCLUDING DATASHEETS), DESIGN RESOURCES (INCLUDING REFERENCE DESIGNS), APPLICATION OR OTHER DESIGN ADVICE, WEB TOOLS, SAFETY INFORMATION, AND OTHER RESOURCES "AS IS" AND WITH ALL FAULTS, AND DISCLAIMS ALL WARRANTIES, EXPRESS AND IMPLIED, INCLUDING WITHOUT LIMITATION ANY IMPLIED WARRANTIES OF MERCHANTABILITY, FITNESS FOR A PARTICULAR PURPOSE OR NON-INFRINGEMENT OF THIRD PARTY INTELLECTUAL PROPERTY RIGHTS.

These resources are intended for skilled developers designing with TI products. You are solely responsible for (1) selecting the appropriate TI products for your application, (2) designing, validating and testing your application, and (3) ensuring your application meets applicable standards, and any other safety, security, or other requirements. These resources are subject to change without notice. TI grants you permission to use these resources only for development of an application that uses the TI products described in the resource. Other reproduction and display of these resources is prohibited. No license is granted to any other TI intellectual property right or to any third party intellectual property right. TI disclaims responsibility for, and you will fully indemnify TI and its representatives against, any claims, damages, costs, losses, and liabilities arising out of your use of these resources.

TI's products are provided subject to TI's Terms of Sale (www.ti.com/legal/termsofsale.html) or other applicable terms available either on ti.com or provided in conjunction with such TI products. TI's provision of these resources does not expand or otherwise alter TI's applicable warranties or warranty disclaimers for TI products.

Mailing Address: Texas Instruments, Post Office Box 655303, Dallas, Texas 75265
Copyright © 2019, Texas Instruments Incorporated

Looking for pricing, stock, or lifecycle information?

Click below to explore more details on WIN SOURCE:

 [View LM3420M5X-8.4/NOPB on WIN SOURCE](#)

 [Texas Instruments](#) Information

Optimize Your Supply Chain with WIN SOURCE Solutions

-  Global Sourcing Solution
-  Obsolete Management
-  Cost Control Management
-  Shortage Management
-  Alternative Solution
-  Excess Inventory Management