



# THE DATASHEET OF LM3414HVMR/NOPB



# LM3414/HV 1-A, 60-W Common Anode-Capable Constant Current Buck LED Driver Requires No External Current Sensing Resistor

## 1 Features

- Supports LED Power up to 60 W <sup>(1)</sup>: 18x 3-W HBLEDs
- Requires **No** External Current Sensing Resistor
- $\pm 3\%$  LED Current Accuracy
- Up to 96% Efficiency
- High Contrast Ratio (Minimum Dimming Current Pulse Width  $< 10 \mu\text{s}$ )
- Integrated Low-Side N-Channel MOSFET
- Adjustable Constant LED Current From 350 mA to 1000 mA
- Support Analog Dimming and Thermal Fold-Back
- Wide Input Voltage Range:
  - 4.5 V to 42 V (LM3414)
  - 4.5 V to 65 V (LM3414HV)
- Constant Switching Frequency Adjustable from 250 kHz to 1000 kHz
- Thermal Shutdown Protection
- Power Enhanced SOIC-8 or 3 mm  $\times$  3 mm WSON-8 Package

## 2 Applications

- High Power LED Drivers
- Architectural Lighting, Office Troffers
- Automotive Lighting
- MR-16 LED Lamps

## 3 Description

The LM3414 and LM3414HV are 1-A 60-W<sup>(1)</sup> common anode-capable constant current buck LED drivers. They are suitable for driving single string of 3-W HBLED with up to 96% efficiency. They accept input voltages from 4.5 VDC to 65 VDC and deliver up to 1-A average LED current with  $\pm 3\%$  accuracy. The integrated low-side N-channel power MOSFET and current sensing element realize simple and low component count circuitry, as no bootstrapping capacitor and external current-sensing resistor are required. An external small-signal resistor to ground provides very fine LED current adjustment, analog dimming, and thermal fold-back functions.

Constant switching frequency operation eases EMI. No external loop compensation network is needed. The proprietary Pulse-Level-Modulation (PLM) control method benefits in high conversion efficiency and true average LED current regulation. Fast response time realizes fine LED current pulse fulfilling the 240 Hz 256-step dimming resolution requirement for general lighting.

The LM3414 and LM3414HV are available in SOIC-8 and 3 mm  $\times$  3 mm WSON-8 packages.

### Device Information<sup>(2)</sup>

PART NUMBER	PACKAGE	BODY SIZE (NOM)
LM3414, LM3414HV	WSON (8)	3.00 mm $\times$ 3.00 mm
	SOIC (8)	3.90 mm $\times$ 4.89 mm

(1) Thermal derating applies according to actual operation conditions.

(2) For all available packages, see the orderable addendum at the end of the data sheet.

### Simplified Application Schematic

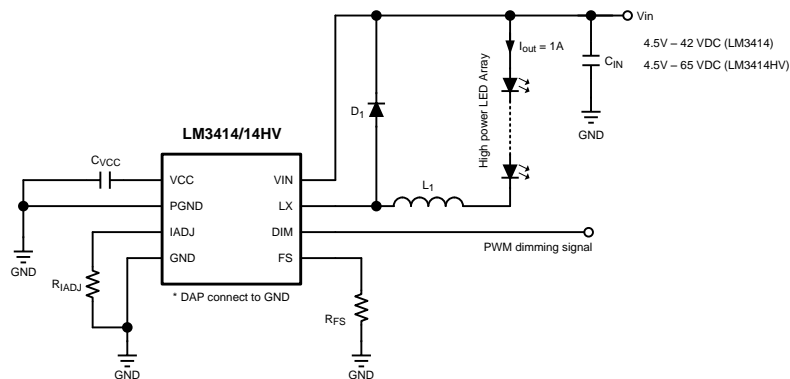

## Table of Contents

<b>1 Features</b> .....	<b>1</b>	7.4 Device Functional Modes.....	<b>15</b>
<b>2 Applications</b> .....	<b>1</b>	<b>8 Application and Implementation</b> .....	<b>16</b>
<b>3 Description</b> .....	<b>1</b>	8.1 Application Information.....	<b>16</b>
<b>4 Revision History</b> .....	<b>2</b>	8.2 Typical Applications .....	<b>18</b>
<b>5 Pin Configuration and Functions</b> .....	<b>3</b>	<b>9 Power Supply Recommendations</b> .....	<b>22</b>
<b>6 Specifications</b> .....	<b>4</b>	<b>10 Layout</b> .....	<b>22</b>
6.1 Absolute Maximum Ratings .....	<b>4</b>	10.1 Layout Guidelines .....	<b>22</b>
6.2 ESD Ratings.....	<b>4</b>	10.2 Layout Example .....	<b>22</b>
6.3 Recommended Operating Conditions.....	<b>4</b>	<b>11 Device and Documentation Support</b> .....	<b>23</b>
6.4 Thermal Information .....	<b>5</b>	11.1 Related Links .....	<b>23</b>
6.5 Electrical Characteristics.....	<b>5</b>	11.2 Community Resources.....	<b>23</b>
6.6 Typical Characteristics .....	<b>6</b>	11.3 Trademarks .....	<b>23</b>
<b>7 Detailed Description</b> .....	<b>9</b>	11.4 Electrostatic Discharge Caution.....	<b>23</b>
7.1 Overview .....	<b>9</b>	11.5 Glossary .....	<b>23</b>
7.2 Functional Block Diagram .....	<b>9</b>	<b>12 Mechanical, Packaging, and Orderable</b>	
7.3 Feature Description.....	<b>10</b>	<b>Information</b> .....	<b>23</b>

## 4 Revision History

NOTE: Page numbers for previous revisions may differ from page numbers in the current version.

<b>Changes from Revision E (May 2013) to Revision F</b>	<b>Page</b>
<ul style="list-style-type: none"> <li>Added <i>ESD Ratings</i> table, <i>Feature Description</i> section, <i>Device Functional Modes</i>, <i>Application and Implementation</i> section, <i>Power Supply Recommendations</i> section, <i>Layout</i> section, <i>Device and Documentation Support</i> section, and <i>Mechanical, Packaging, and Orderable Information</i> section. ....</li> </ul>	<b>1</b>
<ul style="list-style-type: none"> <li>Removed soldering information. ....</li> </ul>	<b>4</b>

<b>Changes from Revision D (April 2013) to Revision E</b>	<b>Page</b>
<ul style="list-style-type: none"> <li>Changed layout of National Data Sheet to TI format .....</li> </ul>	<b>14</b>

## 5 Pin Configuration and Functions

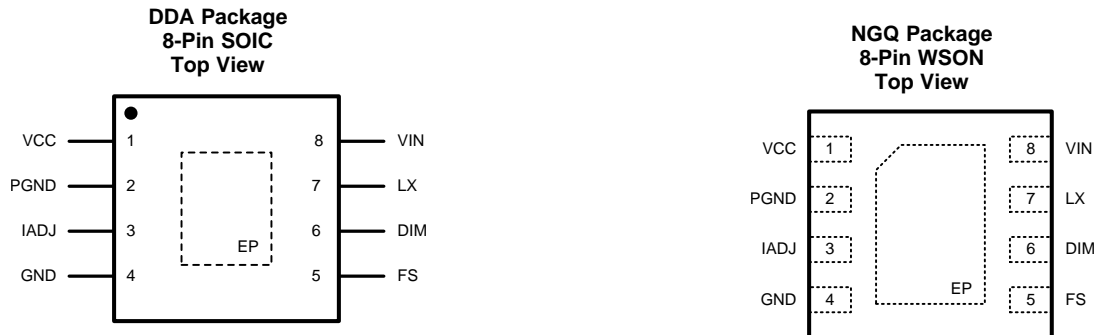

### Pin Functions

PIN		I/O	DESCRIPTION
NAME	NO.		
VCC	1	O	Internal Regulator Output Pin. This pin should be bypassed to ground by a ceramic capacitor with a minimum value of 1 $\mu$ F.
PGND	2	—	Power Ground Pin. Ground for power circuitry. Reference point for all stated voltages. Must be externally connected to EP and GND.
IADJ	3	I	Average Output Current Adjustment Pin. Connect resistor $R_{IADJ}$ from this pin to ground to adjust the average output current.
GND	4	—	Analog Ground Pin. Analog ground connection for internal circuitry, must be connected to PGND external to the package.
FS	5	I	Switching Frequency Setting Pin. Connect resistor $R_{FS}$ from this pin to ground to set the switching frequency.
DIM	6	I	PWM Dimming Control Pin. Apply logic level PWM signal to this pin controls the intend brightness of the LED string.
LX	7	O	Drain of N-MOSFET Switch. Connect this pin to the output inductor and anode of the schottky diode.
VIN	8	I	Input Voltage Pin. The input voltage should be in the range of 4.5 V to 42 V (LM3414) or 4.5 V to 65 V (LM3414HV).
EP	EP	—	Thermal Pad (Power Ground). Used to dissipate heat from the package during operation. Must be electrically connected to PGND external to the package.

## 6 Specifications

### 6.1 Absolute Maximum Ratings

over operating free-air temperature range (unless otherwise noted)<sup>(1)</sup>

		MIN	MAX	UNIT
VIN to GND	LM3414	–0.3	42	V
	LM3414HV	–0.3	65	
VIN to GND (Transient)	LM3414		45 (500 ms)	V
	LM3414HV		67 (500 ms)	
LX to PGND	LM3414	–0.3	42	V
	LM3414HV	–0.3	65	
LX to PGND (Transient)	LM3414	–3 (2 ns)	45 (500 ms)	V
	LM3414HV	–3 (2 ns)	67 (500 ms)	
FS, IADJ to GND		–0.3	5	V
DIM to GND		–0.3	6	V
Storage Temperature		–65	125	°C

(1) Stresses beyond those listed under *Absolute Maximum Ratings* may cause permanent damage to the device. These are stress ratings only, which do not imply functional operation of the device at these or any other conditions beyond those indicated under *Recommended Operating Conditions*. Exposure to absolute-maximum-rated conditions for extended periods may affect device reliability.

### 6.2 ESD Ratings

		VALUE	UNIT
<b>WSON PACKAGE</b>			
V <sub>(ESD)</sub> Electrostatic discharge	Human-body model (HBM), per ANSI/ESDA/JEDEC JS-001 <sup>(1)(2)</sup>	±2000	V
	Charged-device model (CDM), per JEDEC specification JESD22-C101 <sup>(3)</sup>	±750	
<b>SOIC PACKAGE</b>			
V <sub>(ESD)</sub> Electrostatic discharge	Human-body model (HBM), per ANSI/ESDA/JEDEC JS-001 <sup>(1)(2)</sup>	±2000	V
	Charged-device model (CDM), per JEDEC specification JESD22-C101 <sup>(3)</sup>	±750	

(1) JEDEC document JEP155 states that 500-V HBM allows safe manufacturing with a standard ESD control process.

(2) The human body model is a 100pF capacitor discharged through a 1.5 kΩ resistor into each pin.

(3) JEDEC document JEP157 states that 250-V CDM allows safe manufacturing with a standard ESD control process.

### 6.3 Recommended Operating Conditions

over operating free-air temperature range (unless otherwise noted)

		MIN	NOM	MAX	UNIT
V <sub>IN</sub>	LM3414	4.5		42	V
	LM3414HV	4.5		65	
Junction temperature		–40		125	°C

## 6.4 Thermal Information

THERMAL METRIC <sup>(1)</sup>		LM3414, LM3414HV		UNIT
		NGQ (WSON)	DDA (SOIC-8)	
		8 PINS	8 PINS	
R <sub>θJA</sub>	Junction-to-ambient thermal resistance	47.7	50.5	°C/W
R <sub>θJC(top)</sub>	Junction-to-case (top) thermal resistance	43.1	55.7	°C/W
R <sub>θJB</sub>	Junction-to-board thermal resistance	22.3	28.6	°C/W
ψ <sub>JT</sub>	Junction-to-top characterization parameter	0.4	9.5	°C/W
ψ <sub>JB</sub>	Junction-to-board characterization parameter	22.5	28.5	°C/W
R <sub>θJC(bot)</sub>	Junction-to-case (bottom) thermal resistance	4	3.2	°C/W

(1) For more information about traditional and new thermal metrics, see the *Semiconductor and IC Package Thermal Metrics* application report, [SPRA953](#).

## 6.5 Electrical Characteristics

MIN and MAX limits apply for T<sub>J</sub> = –40°C to 125°C unless specified otherwise. V<sub>IN</sub> = 24 V unless otherwise indicated.

PARAMETER		TEST CONDITIONS	MIN <sup>(1)</sup>	TYP <sup>(2)</sup>	MAX <sup>(1)</sup>	UNIT
<b>SYSTEM PARAMETERS - LM3414</b>						
I <sub>IN-DIM-HIGH</sub>	Operating Current	4.5 V ≤ V <sub>in</sub> ≤ 42 V R <sub>IADJ</sub> = 3.125 kΩ V <sub>DIM</sub> = High	2.2	3.2	3.5	mA
I <sub>IN-DIM-LOW</sub>	Standby Current	4.5 V ≤ V <sub>in</sub> ≤ 42 V R <sub>IADJ</sub> = 3.125 kΩ V <sub>DIM</sub> = Low	0.8	1.15	1.4	mA
I <sub>LX-OFF</sub>	LX Pin Current	Main Switch Turned OFF V <sub>LX</sub> = V <sub>IN</sub> = 42 V		6		μA
<b>SYSTEM PARAMETERS - LM3414HV</b>						
I <sub>IN-DIM-HIGH</sub>	Operating Current	4.5 V ≤ V <sub>in</sub> ≤ 65 V R <sub>IADJ</sub> = 3.125 kΩ V <sub>DIM</sub> = High	2.2	3.3	3.6	mA
I <sub>IN-DIM-LOW</sub>	Standby Current	4.5 V ≤ V <sub>in</sub> ≤ 65 V R <sub>IADJ</sub> = 3.125 kΩ V <sub>DIM</sub> = Low	0.8	1.2	1.45	mA
I <sub>LX-OFF</sub>	LX Pin Current	Main Switch Turned OFF V <sub>LX</sub> = V <sub>IN</sub> = 65 V		6.5		μA
<b>SYSTEM PARAMETERS - LM3414/3414HV</b>						
I <sub>LED</sub>	Average LED Current	R <sub>IADJ</sub> = 3.125 kΩ T <sub>A</sub> = 25°C	0.97	1	1.03	A
		R <sub>IADJ</sub> = 3.125 kΩ T <sub>A</sub> = –40°C to 125°C	0.95	1	1.05	A
V <sub>CC-UVLO</sub>	V <sub>CC</sub> UVLO Threshold	V <sub>CC</sub> Decreasing, T <sub>A</sub> = 25°C	3.6	3.75	3.9	V
V <sub>CC-UVLO-HYS</sub>	V <sub>CC</sub> UVLO Hysteresis			300		mV
V <sub>IADJ</sub>	IADJ Pin voltage		1.23	1.255	1.280	V
V <sub>DIM</sub>	DIM Pin Threshold	V <sub>DIM</sub> Increasing		1	1.2	V
V <sub>DIM-HYS</sub>	DIM Pin Hysteresis			100		mV
f <sub>SW</sub>	Switching frequency		250	500	1000	kHz
f <sub>SW-TOL</sub>	Switching frequency tolerance	R <sub>FS</sub> = 40 kΩ	420	500	580	kHz
t <sub>ON-MIN</sub>	Minimum on-time				400	ns

- All limits specified at room temperature (TYP) and at temperature extremes (MIN/MAX). All room temperature limits are 100% production tested. All limits at temperature extremes are specified through correlation using standard Statistical Quality Control (SQC) methods. All limits are used to calculate Average Outgoing Quality Level (AOQL).
- Typical specification represent the most likely parametric norm at 25°C operation.

### Electrical Characteristics (continued)

MIN and MAX limits apply for  $T_J = -40^{\circ}\text{C}$  to  $125^{\circ}\text{C}$  unless specified otherwise.  $V_{IN} = 24\text{ V}$  unless otherwise indicated.

PARAMETER	TEST CONDITIONS	MIN <sup>(1)</sup>	TYP <sup>(2)</sup>	MAX <sup>(1)</sup>	UNIT	
<b>INTERNAL VOLTAGE REGULATOR</b>						
$V_{CC}$	$V_{CC}$ regulator output voltage <sup>(3)</sup>	$C_{VCC} = 1\ \mu\text{F}$ , No Load to $I_{VCC} = 2\ \text{mA}$	4.7	5.4	6	V
		$V_{IN} = 4.5\ \text{V}$ , 2-mA Load	3.8	4.2		V
<b>MAIN SWITCH</b>						
$R_{LX}$	Resistance across LX and GND	Main Switch Turned ON		1.8	$\Omega$	
<b>THERMAL PROTECTION</b>						
$T_{SD}$	Thermal shutdown temperature	$T_J$ Rising		170	$^{\circ}\text{C}$	
$T_{SD-HYS}$	Thermal shutdown temperature hysteresis	$T_J$ Falling		10	$^{\circ}\text{C}$	

(3)  $V_{CC}$  provides self bias for the internal gate drive and control circuits. Device thermal limitations limit external loading to the pin.

### 6.6 Typical Characteristics

All curves taken at  $V_{IN} = 48\text{ V}$  with configuration in typical application for driving twelve power LEDs with  $I_{LED} = 1\text{ A}$  shown in this data sheet.  $T_A = 25^{\circ}\text{C}$ , unless otherwise specified.

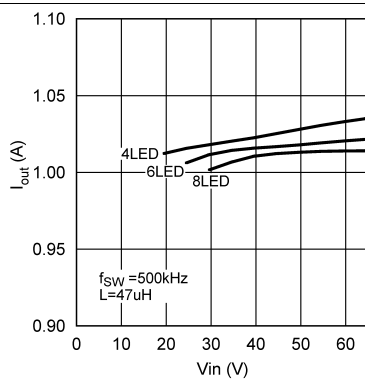

Figure 1.  $I_{OUT}$  vs  $V_{IN}$ , (4 - 8 LED), LM3414HV

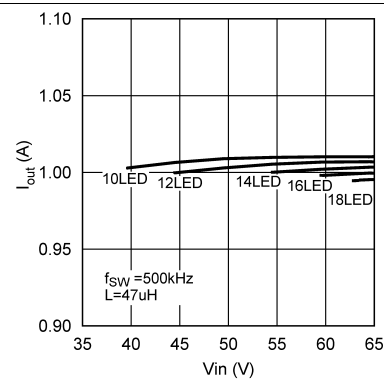

Figure 2.  $I_{OUT}$  vs  $V_{IN}$ , (10 - 18 LED), LM3414HV

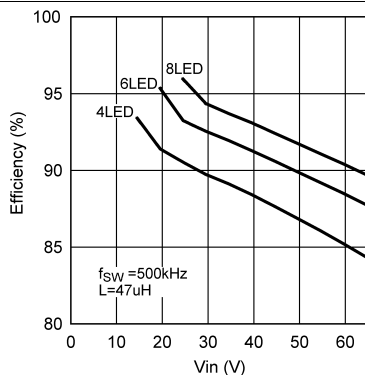

Figure 3. Efficiency vs  $V_{IN}$ , (4 - 8 LED), LM3414HV

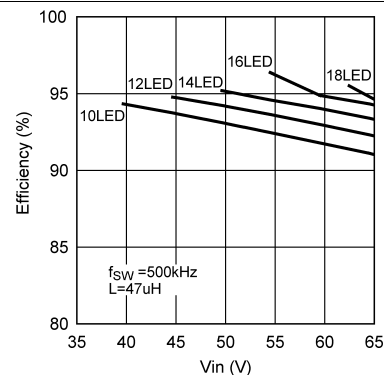
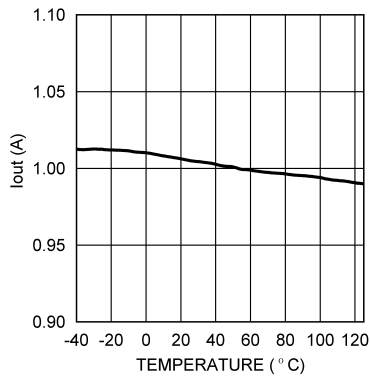

Figure 4. Efficiency vs  $V_{IN}$ , (10 - 18 LED), LM3414HV

**Typical Characteristics (continued)**

All curves taken at  $V_{IN} = 48\text{ V}$  with configuration in typical application for driving twelve power LEDs with  $I_{LED} = 1\text{ A}$  shown in this data sheet.  $T_A = 25^\circ\text{C}$ , unless otherwise specified.



**Figure 5.  $I_{OUT}$  vs Temperature ( $T_A$ )  
(6 LED,  $V_{IN} = 24\text{ V}$ ), LM3414HV**

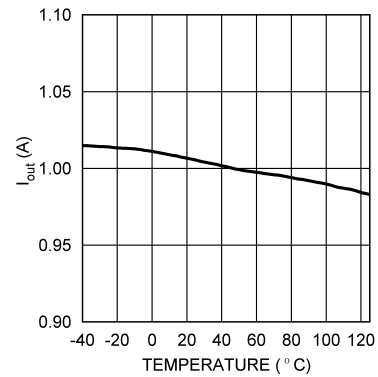

**Figure 6.  $I_{OUT}$  vs Temperature ( $T_A$ )  
(12 LED,  $V_{IN} = 48\text{ V}$ ), LM3414HV**

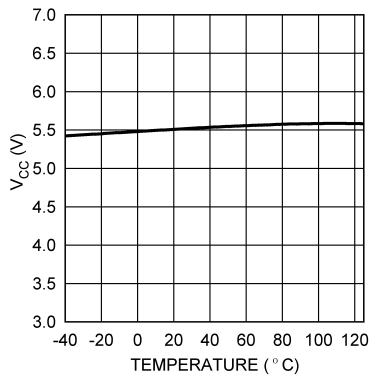

**Figure 7.  $V_{CC}$  vs Temperature ( $T_A$ ), LM3414HV**

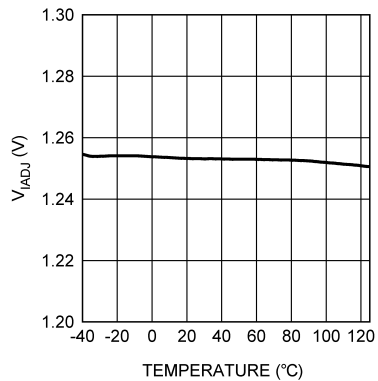

**Figure 8.  $V_{IADJ}$  vs Temperature ( $T_A$ ), LM3414HV**

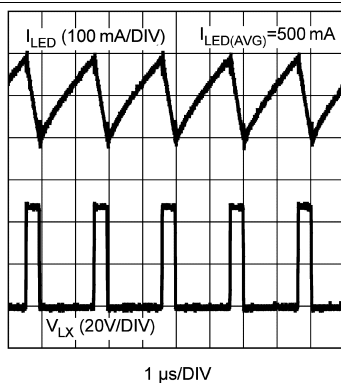

**Figure 9.  $I_{OUT}$  and  $V_{LX}$ , LM3414HV**

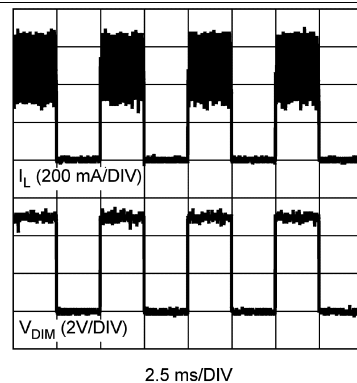

**Figure 10.  $I_{LX}$  and  $V_{DIM}$ , LM3414HV**

### Typical Characteristics (continued)

All curves taken at  $V_{IN} = 48\text{ V}$  with configuration in typical application for driving twelve power LEDs with  $I_{LED} = 1\text{ A}$  shown in this data sheet.  $T_A = 25^\circ\text{C}$ , unless otherwise specified.

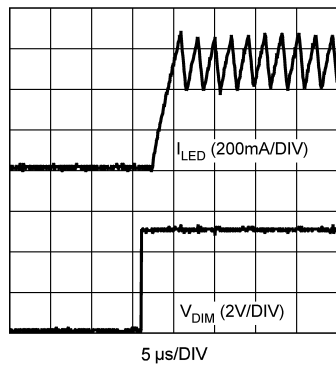

**Figure 11. LED Current With PWM Dimming ( $V_{DIM}$  Rising), LM3414HV**

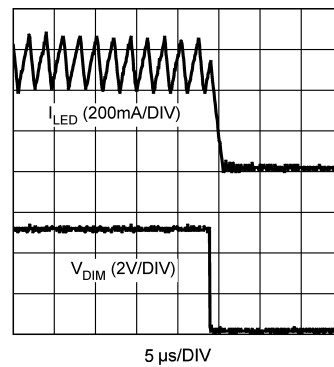

**Figure 12. LED Current With PWM Dimming ( $V_{DIM}$  Falling), LM3414HV**

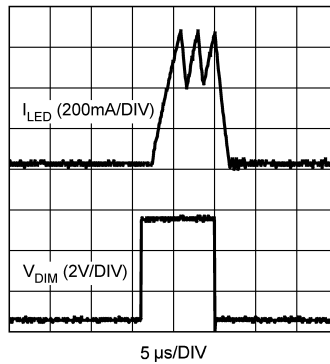

**Figure 13. LED Current With PWM Dimming (9- $\mu\text{s}$  dimming pulse), LM3414HV**

## 7 Detailed Description

### 7.1 Overview

The LM3414/HV is a high power floating buck LED driver with wide input voltage ranges. The device requires no external current sensing elements and loop compensation networks. The integrated power N-MOSFET enables high-output power with up to 1000-mA output current. The combination of Pulse Width Modulation (PWM), control architecture, and the proprietary Pulse Level Modulation (PLM) ensures accurate current regulation, good EMI performance, and provides high flexibility on inductor selection. High-speed dimming control input allows precision and high resolution brightness control for applications require fine brightness adjustment.

### 7.2 Functional Block Diagram

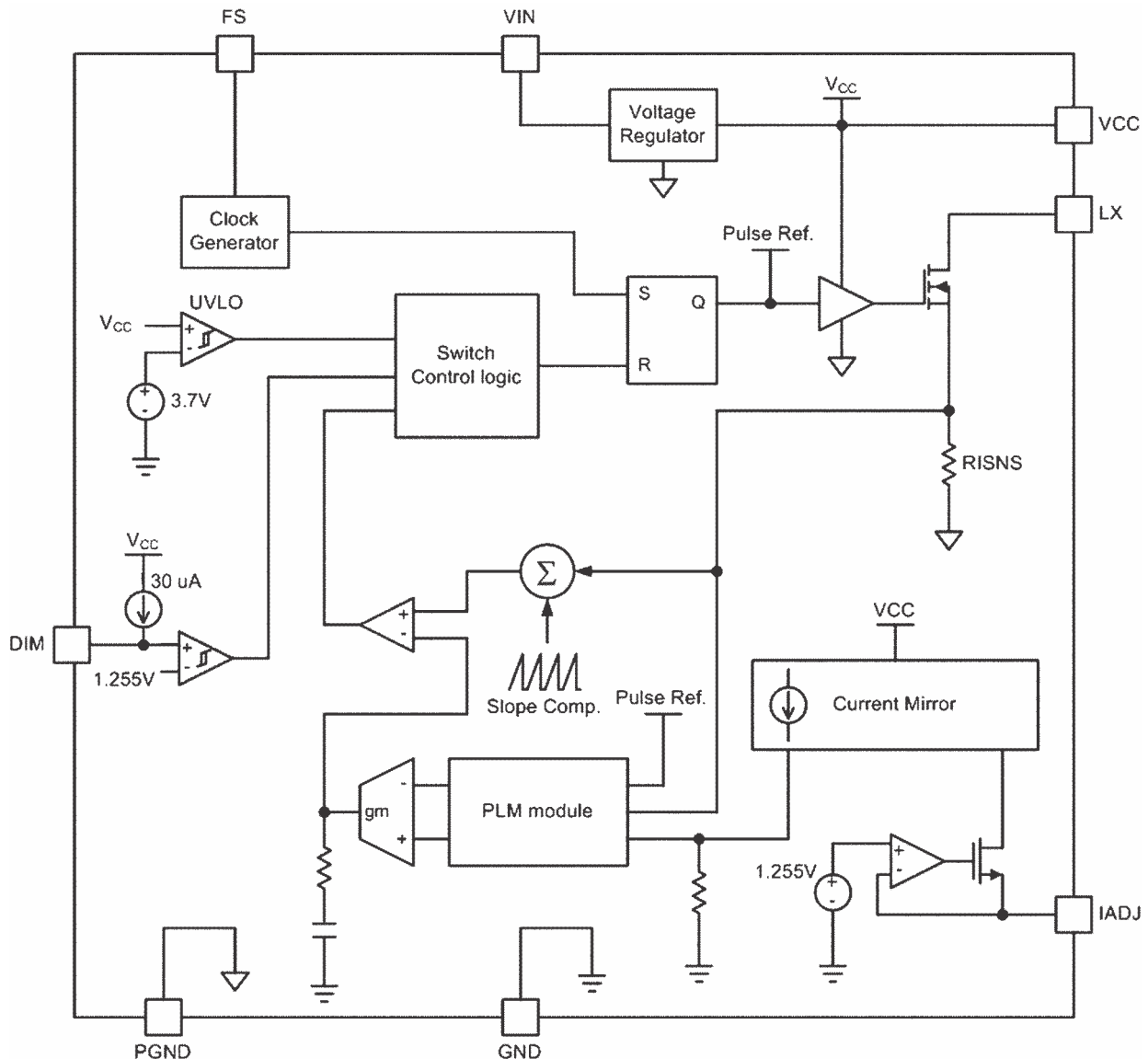

### 7.3 Feature Description

#### 7.3.1 Pulse-Level-Modulation (PLM) Operation Principles

The main control circuitry of the LM3414/HV is generally a Pulse-Width-Modulated (PWM) controller with the incorporation of the Pulse-Level-Modulation (PLM) technology. PLM is a technology that facilitates true output average current control without the need to sense the output current directly. In the LM3414/LM3414HV, the PLM circuit senses the current of the internal switch through integrated current sensing circuitry to realize average output current control. The use of PLM reduces the current sensing power losses as it needs current information only when the switch is turned ON. For proper operation of this control scheme, the converter must operate in CCM (continuous conduction mode), so the switching frequency and inductor value must be chosen to prevent the inductor current reaching 0 A during the switch OFF time each cycle.

In general, for the LED drivers with current sensing resistor at the output, the power dissipation on the current sensing resistor is  $I_{LED}^2 \times R_{ISNS}$ , where  $I_{LED}$  is the average output current and  $R_{ISNS}$  is the resistance of the current sensing resistor. In the LM3414/LM3414HV, power dissipates on the internal  $R_{ISNS}$  only during ON period of the internal power switch. The power loss on  $R_{ISNS}$ (internal) becomes  $I_{LED}^2 \times R_{ISNS} \times D$ , where  $D$  is the switching duty cycle. For example, when the switching duty cycle,  $D$  of a converter is 0.5, the power loss on  $R_{ISNS}$  with PLM is half of those with conventional output current sensing resulting in increased efficiency.

The Pulse-Level-Modulation is a patented method to ensure accurate average output current regulation without the need of direct output current sensing. Figure 14 shows the current waveforms of a typical buck converter under steady state, where,  $I_{L1}$  is the inductor current and  $I_{LX}$  is the main switch current flowing into the LX pin. For a buck converter operating in steady state, the mid-point of the RAMP section of the main switch current is equal to the average level of the inductor current—hence the average output current. In short, by regulating the mid-point of the RAMP section of the main switch current with respect to a precise reference level, PLM achieves output current regulation by sensing the main switch current solely.

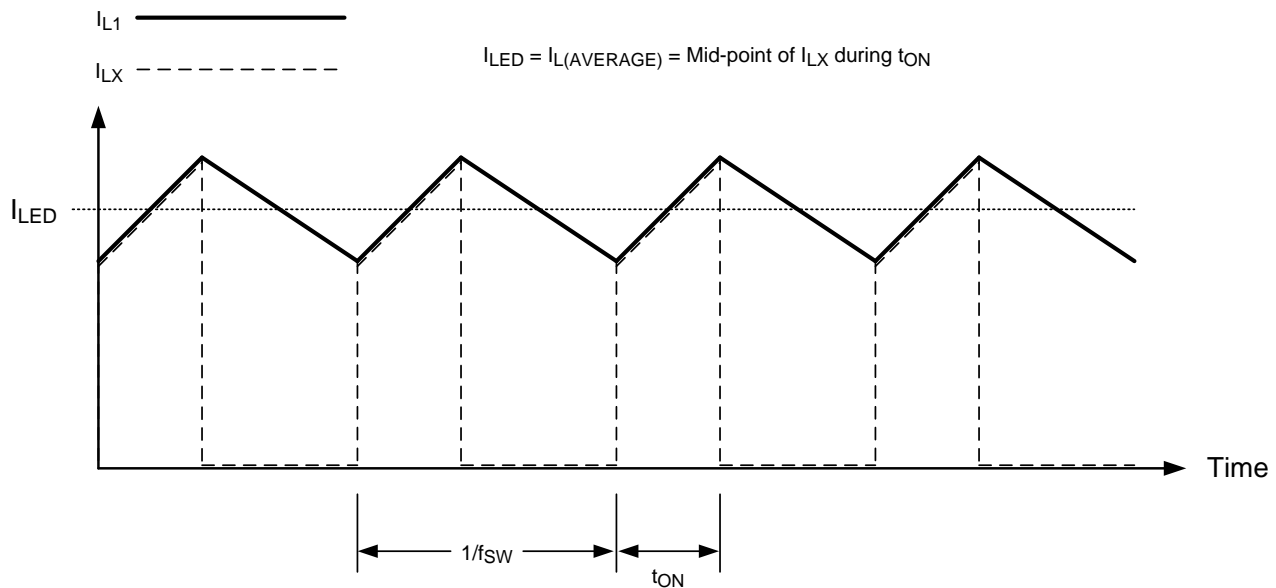

Figure 14. Waveforms of a Floating Buck LED Driver With PLM

#### 7.3.2 Minimum Switch ON-time

As the LM3414 features a 400 ns minimum ON time, it is essential to make sure the ON time of the internal switch is not shorter than 400 ns when setting the LED driving current. If the switching ON time is shorter than 400 ns, the accuracy of the LED current may not maintain and exceed the rated current of the LEDs. The ratio of the LED forward voltage to input voltage is restricted by the following restriction, as shown in Equation 1.

$$\frac{V_{LED}}{V_{IN}} \geq 400 \text{ nS} \times f_{SW} \tag{1}$$

## Feature Description (continued)

### 7.3.3 Peak Switch Current Limit

The LM3414/HV features an integrated switch current limiting mechanism that protects the LEDs from being overdriven. The switch current limiter triggers when the switch current exceeds three times the current level set by  $R_{IADJ}$ . Once the current limiter is triggered, the internal power switch turns OFF for 3.6  $\mu$ s to allow the inductor to discharge and cycles repetitively until the overcurrent condition is removed. The current limiting feature is exceptionally important to avoid permanent damage of the LM3414/HV application circuit due to short circuit of LED string.

### 7.3.4 PWM Dimming Control

The DIM pin of the LM3414/HV is an input with internal pullup that accepts logic signals for average LED current control. Applying a logic high (greater than 1.2 V) signal to the DIM pin or leaving the DIM pin open will enable the device. Applying a logic low signal (less than 0.9 V) to the DIM pin will disable the switching activity of the device but maintain VCC regulator active. The LM3414/HV allows the inductor current to slew up to the preset regulated level at full speed instead of charging the inductor with multiple restrained switching duty cycles. This enables the LM3414/HV to achieve high-speed dimming and very fine dimming control as shown in [Figure 15](#) and [Figure 16](#).

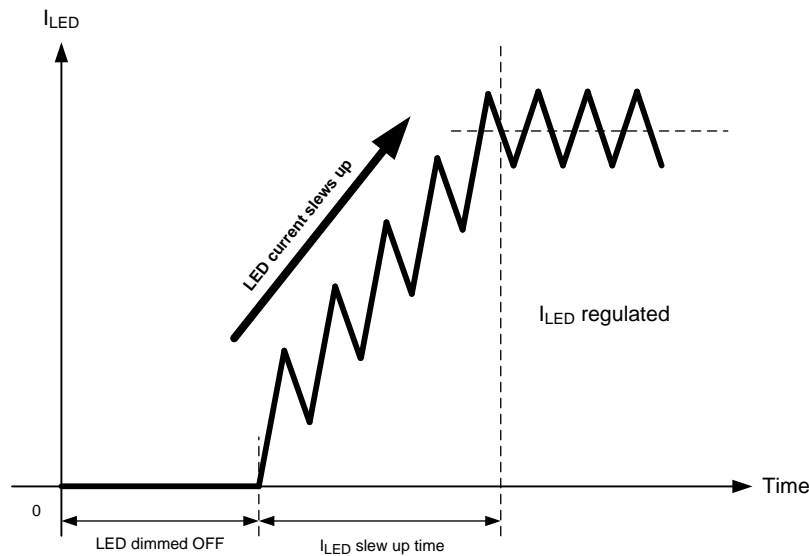

**Figure 15. LED Current Slew Up With Multiple Switching Cycle**

Feature Description (continued)

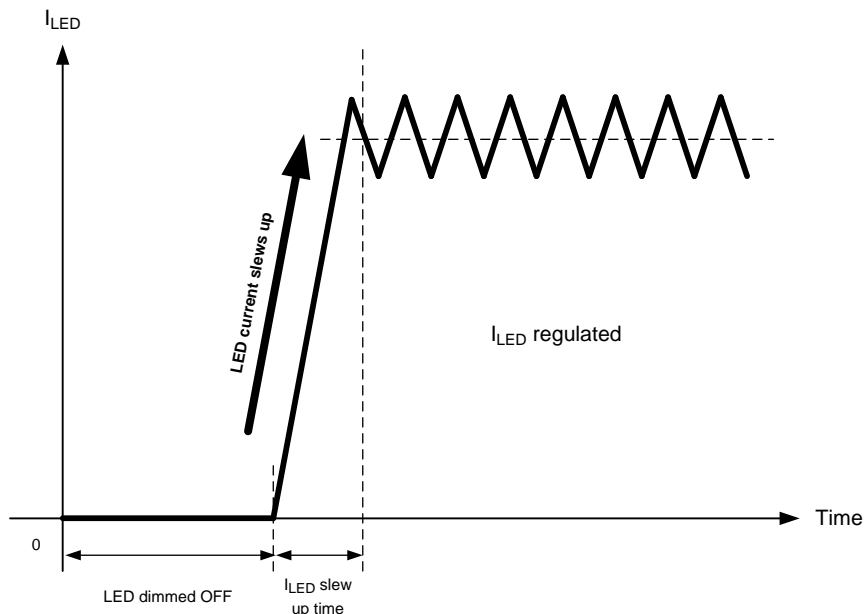

Figure 16. Shortened Current Slew Up Time of the LM3414/HV

To ensure normal operation of the LM3414/HV, TI recommends setting the dimming frequency not higher than 1/10 of the switching frequency. The minimum dimming duty cycle is limited by the 400 ns minimum ON time. In applications that require high dimming contrast ratio, low dimming frequency should be used.

7.3.5 Analog Dimming Control

The IADJ pin can be used as an analog dimming signal input. As the average output current of the LM3414 depends on the current being drawn from the IADJ pin, thus the LED current can be increased or decreased by applying external bias current to the IADJ pin. The simplified circuit diagram for facilitating analog dimming is as shown in Figure 17. The minimum LED current for analog dimming is 100 mA and the converter must remain in continuous conduction mode (CCM). The switching frequency and inductor value must be sized accordingly.

Feature Description (continued)

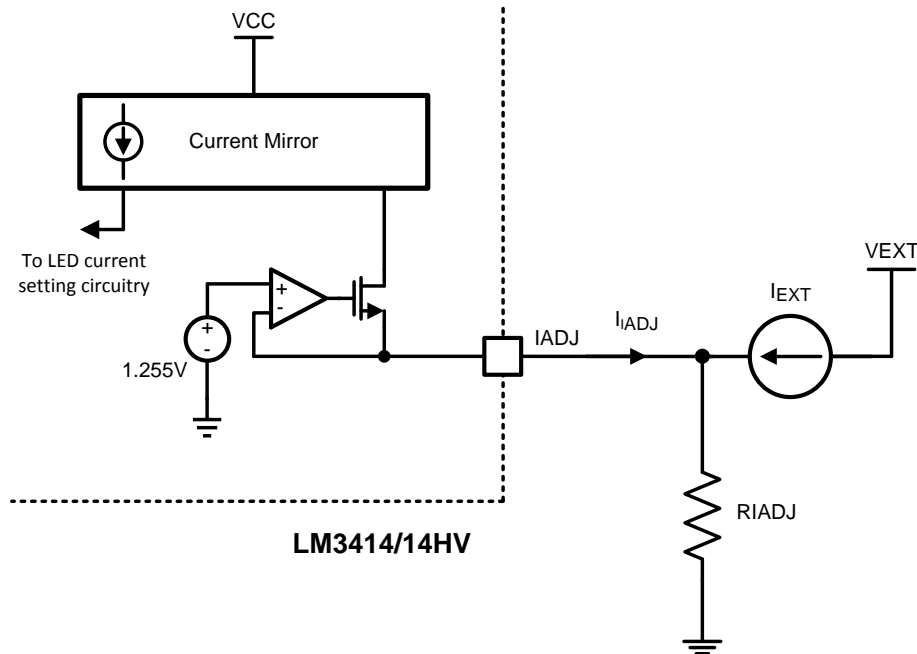

Figure 17. Analog LED Current Control Circuit

When external bias current  $I_{EXT}$  is applied to the I<sub>ADJ</sub> pin, the reduction of LED current follows Equation 2 through Equation 3.

$$I_{LED} = \left[ \left( \frac{1.255}{R_{IADJ}} - I_{EXT} \right) \times 2490 \times 10^3 \right] \text{ mA} \quad (2)$$

Provided that

$$I_{EXT} < \frac{1.255}{R_{IADJ}} \quad (3)$$

$I_{LED}$  decreases linearly as  $I_{EXT}$  increases.

This feature is exceptionally useful for the applications with analog dimming control signals such as those from analog temperature sensors and ambient light sensors.

Figure 18 shows an example circuit for analog dimming control using simple external biasing circuitry with a variable resistor.

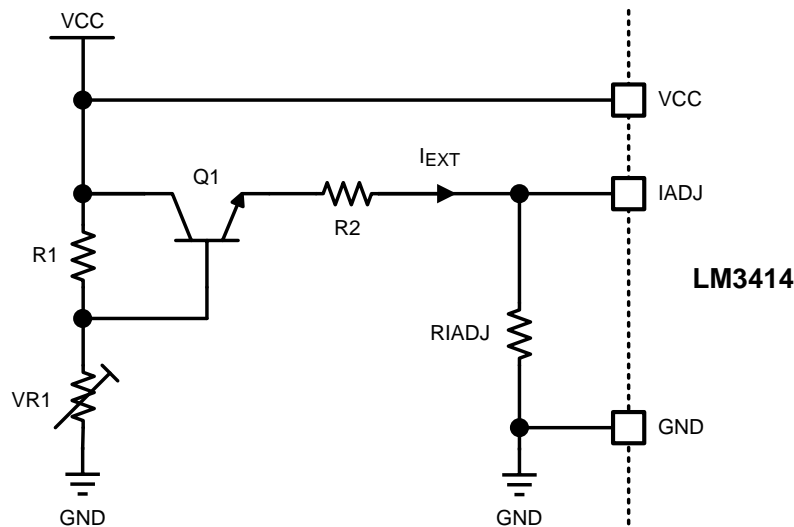
**Feature Description (continued)**

**Figure 18. Example Analog Dimming Control Circuit**

In [Figure 18](#), the variable resistor VR1 controls the base voltage of Q1 and eventually adjusts the bias voltage of current to the IADJ pin ( $I_{EXT}$ ). As the resistance of VR1 increases and the voltage across VR1 exceeds  $1.255\text{ V} + 0.7\text{ V}$ , the LED current starts to decrease as  $I_{EXT}$  increases.

Where

$$I_{EXT} = \left[ \frac{VCC - 1.955 \left( \frac{R1}{VR1} + 1 \right)}{R2 \left( \frac{R1}{VR1} + 1 \right)} \right] \text{ mA} \quad (4)$$

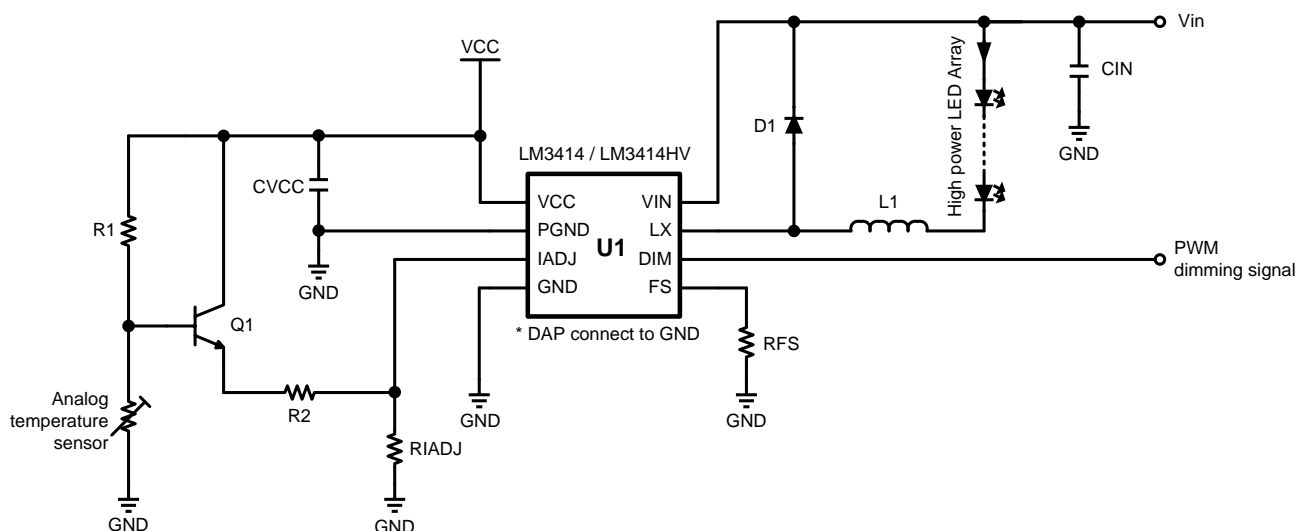
The analog dimming begins only when  $I_{EXT} > 0$ .

**Figure 19. Application Circuit of LM3414/HV With Temperature Fold-Back Circuitry and PWM Dimming**

## Feature Description (continued)

### 7.3.6 Internal VCC Regulator

The LM3414/HV features a 5.4-V internal voltage regulator that connects between the VIN and VCC pins for powering internal circuitry and provide biases to external components. The VCC pin must be bypassed to the GND pin with a 1- $\mu$ F ceramic capacitor,  $C_{VCC}$  that connected to the pins as close as possible. When the input voltage falls to less than 6 V, the VCC voltage will drop to less than 5.4 V and decrease proportionally as  $V_{in}$  decreases. The device will shutdown as the VCC voltage falls to less than 3.9 V. When the internal regulator is used to provide bias to external circuitry, it is essential to ensure the current sinks from VCC pin does not exceed 2 mA to maintain correct voltage regulation.

## 7.4 Device Functional Modes

There are no additional functional modes for this device.

## 8 Application and Implementation

### NOTE

Information in the following applications sections is not part of the TI component specification, and TI does not warrant its accuracy or completeness. TI's customers are responsible for determining suitability of components for their purposes. Customers should validate and test their design implementation to confirm system functionality.

### 8.1 Application Information

#### 8.1.1 Setting the Switching Frequency

Both the LM3414 and LM3414HV are PWM LED drivers that contain a clock generator to generate constant switching frequency for the device. The switching frequency is determined by the resistance of an external resistor  $R_{FS}$  in the range of 250 kHz to 1 MHz. Lower resistance of  $R_{FS}$  results in higher switching frequency. The switching frequency of the LM3414/HV is governed using [Equation 5](#).

$$f_{SW} = \frac{20 \times 10^6}{R_{FS}} \text{ kHz} \quad (5)$$

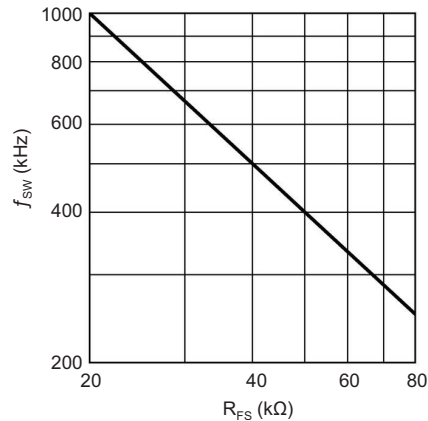

**Figure 20. Switching Frequency vs  $R_{FS}$**

**Table 1. Examples for  $f_{SW}$  Settings**

$f_{SW}$ (kHz)	$R_{FS}$ (k $\Omega$ )
250	80
500	40
1000	20

To ensure accurate current regulation, the LM3414/HV should be operated in continuous conduction mode (CCM) and the ON time should not be shorter than 400 ns under all operation condition.

#### 8.1.2 Setting LED Current

The LM3414/HV requires no external current sensing resistor for LED current regulation. The average output current of the LM3414/HV is adjustable by varying the resistance of the resistor,  $R_{IADJ}$  that connects across the IADJ and GND pins. The IADJ pin is internally biased to 1.255 V. The LED current is then governed by [Equation 6](#).

$$I_{LED} = \frac{3125 \times 10^3}{R_{IADJ}} \text{ mA}$$

where

- $350 \text{ mA} < I_{LED} < 1\text{A}$  (6)

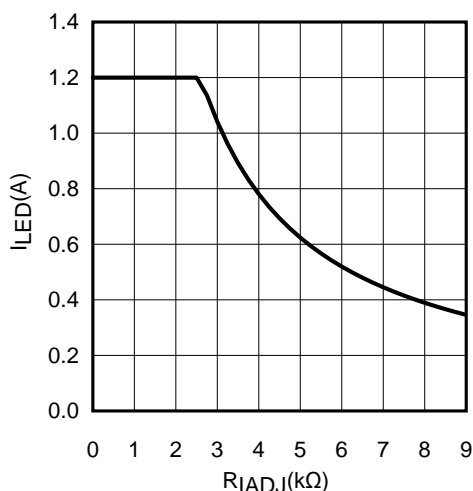

Figure 21. LED Current vs R<sub>IADJ</sub>

Table 2. Examples for I<sub>OUT</sub> Settings

I <sub>OUT</sub> (mA)	R <sub>IADJ</sub> (kΩ)
350	8.93
500	6.25
700	4.46
1000	3.13

The LED current can be set to any level in the range from 350 mA to 1A. To provide accurate LED current, R<sub>IADJ</sub> should be a resistor with no more than 0.5% tolerance. If the IADJ pin is accidentally shorted to GND (R<sub>IADJ</sub> = 0), the output current is limited to avoid damaging the circuit. When the overcurrent protection is activated, current regulation cannot be maintained until the overcurrent condition is cleared.

### 8.1.3 Inductor Selection

To ensure proper output current regulation, the LM3414/HV must operate in Continuous Conduction Mode (CCM). With the incorporation of PLM, the peak-to-peak inductor current ripple can be set as high as ±60% of the defined average output current. The minimum inductance of the inductor is decided by the defined average LED current and allowable inductor current ripple. The minimum inductance can be found by the equations shown in Equation 7 through Equation 8.

Because:

$$\Delta I_L = \frac{V_{IN} - V_{LED}}{L} \times D \times T \tag{7}$$

Thus:

$$L_{MIN} = \frac{V_{IN} - V_{LED}}{1.2 \times I_{LED}} \times \frac{V_{LED}}{V_{IN}} \times \frac{1}{f_{SW}} \tag{8}$$

The LM3414/HV can maintain LED current regulation without output filter capacitor. This is because the inductor of the floating buck structure provides continuous current to the LED throughout the entire switching cycle. When LEDs are driven without filter capacitor, the LED peak current must not set exceeding the rated current of the LED. The peak LED current is governed by Equation 9.

$$\Delta I_L = \left[ \frac{(V_{IN} - V_{LED}) V_{LED}}{2L \times V_{IN} \times f_{SW}} \right] + I_{LED(AVG)} \tag{9}$$

## 8.2 Typical Applications

### 8.2.1 LM3414/HV Design Example

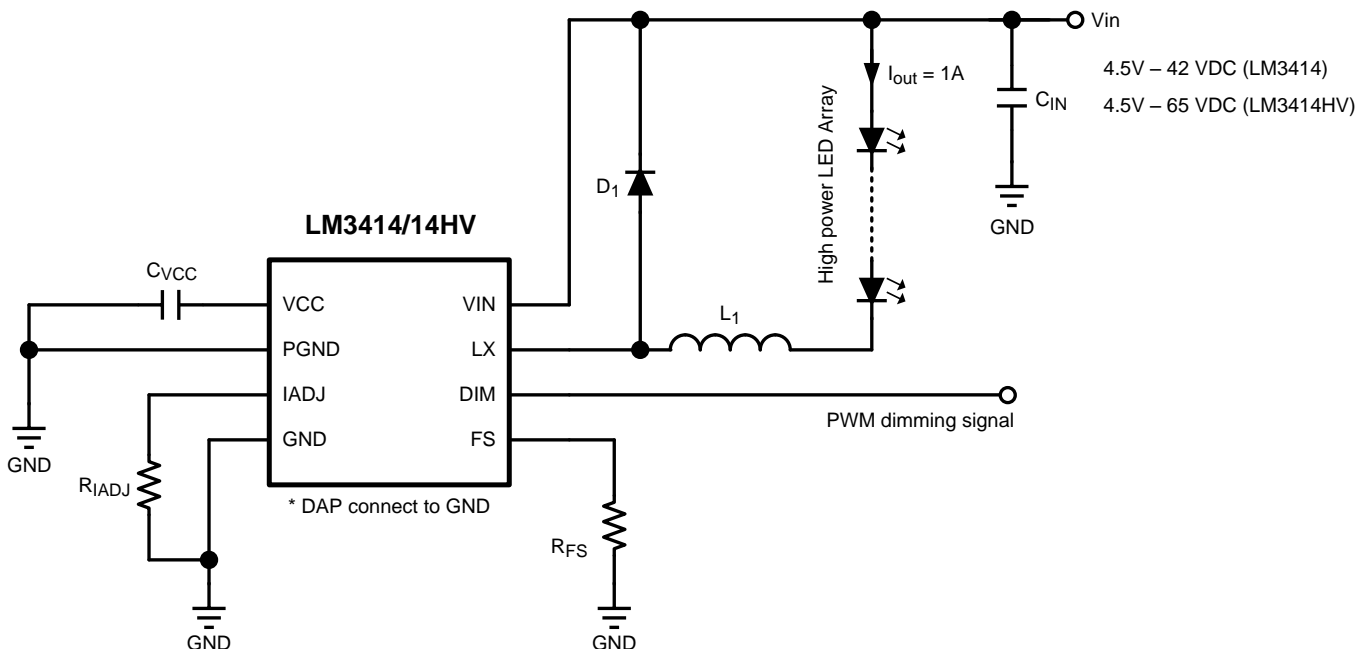

**Figure 22. LM3414/HV Design Example Schematic**

#### 8.2.1.1 Design Requirements

- Input Voltage:  $V_{IN}$
- LED String Voltage:  $V_{LED}$
- LED Current:  $I_{LED}$
- Switching Frequency:  $f_{SW}$
- Maximum LED Current Ripple:  $\Delta i_{L-PP}$
- Maximum Input Voltage Ripple:  $\Delta V_{IN}$

#### 8.2.1.2 Detailed Design Procedure

##### 8.2.1.2.1 Calculate Operating Parameters

To calculate component values the operating duty cycle (D) must be calculated using [Equation 10](#).

$$D = \frac{V_{LED}}{V_{IN}} \quad (10)$$

##### 8.2.1.2.2 Calculate $R_{IADJ}$

To get the desired LED current calculate the value for  $R_{IADJ}$  using [Equation 11](#).

$$R_{IADJ} = \frac{3125}{I_{LED}} \quad (11)$$

##### 8.2.1.2.3 Calculate $R_{FS}$

Calculate the value of  $R_{FS}$  for the desired switching frequency using [Equation 12](#).

$$R_{FS} = \frac{20 \times 10^9}{f_{SW}} \quad (12)$$

## Typical Applications (continued)

### 8.2.1.2.4 Calculate $L_{MIN}$

Calculate the minimum inductor value required for the desired LED current ripple using Equation 13.

$$L_{MIN} = \frac{(V_{IN} - V_{LED}) \times V_{LED}}{f_{SW} \times V_{IN} \times \Delta i_{L-PP}} \quad (13)$$

### 8.2.1.2.5 Calculate $C_{IN-MIN}$

Calculate the minimum input capacitor value for the desired input voltage ripple using Equation 14.

$$C_{IN-MIN} = \frac{D \times (1 - D) \times I_{LED}}{f_{SW} \times \Delta V_{IN}} \quad (14)$$

## 8.2.2 LM3414/HV Design Example ( $I_{OUT} = 1 A$ )

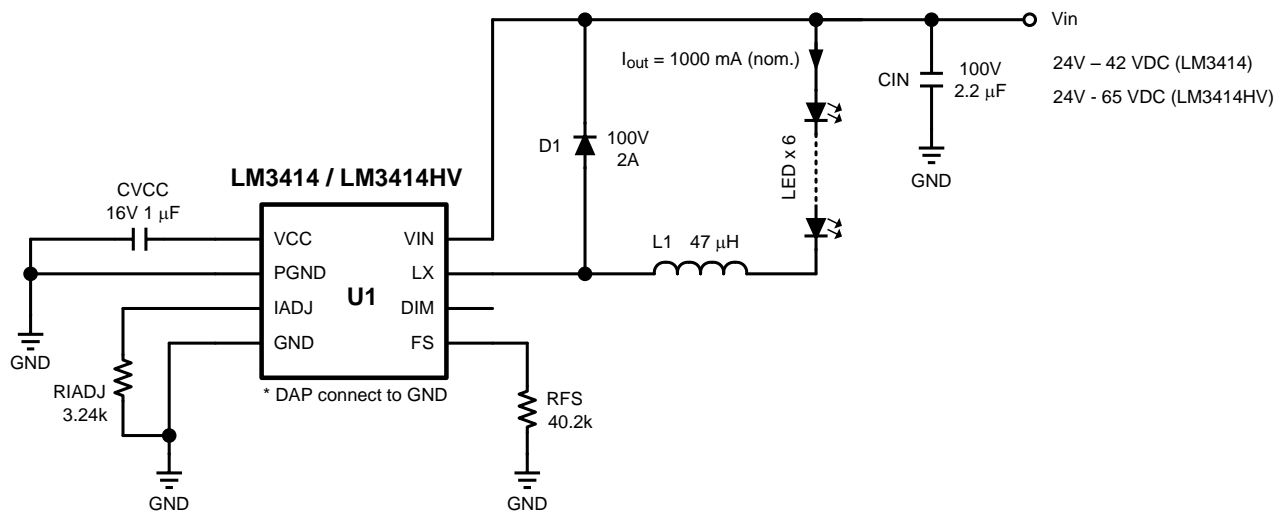

Figure 23. LM3414/HV Design Example ( $I_{OUT} = 1 A$ ) Schematic

### 8.2.2.1 Design Requirements

- Input Voltage:  $V_{IN} = 48 V \pm 10\%$
- LED String Voltage:  $V_{LED} = 35 V$
- LED Current:  $I_{LED} = 1 A$
- Switching Frequency:  $f_{SW} = 500 kHz$
- Maximum LED Current Ripple:  $\Delta i_{L-PP} \leq 500 mA$
- Maximum Input Voltage Ripple:  $\Delta V_{IN} \leq 200 mV$

### 8.2.2.2 Detailed Design Procedure

#### 8.2.2.2.1 Calculate Operating Parameters

To calculate component values the operating duty cycle (D) for this application can be calculated using Equation 15.

$$D = \frac{V_{LED}}{V_{IN}} = \frac{35V}{48V} = 0.73 \quad (15)$$

#### 8.2.2.2.2 Calculate $R_{IADJ}$

For 1A LED current calculate the value for  $R_{IADJ}$  using Equation 16.

**Typical Applications (continued)**

$$R_{IADJ} = \frac{3125}{I_{LED}} = \frac{3125}{1A} = 3.125k\Omega \quad (16)$$

Choose a standard value of  $R_{IADJ} = 3.24k\Omega$ .

**8.2.2.2.3 Calculate  $R_{FS}$** 

Calculate the value of  $R_{FS}$  for 500-kHz switching frequency using [Equation 17](#).

$$R_{FS} = \frac{20 \times 10^9}{f_{SW}} = \frac{20 \times 10^9}{500kHz} = 40k\Omega \quad (17)$$

Choose a standard value of  $R_{FS} = 40.2k\Omega$ .

**8.2.2.2.4 Calculate  $L_{MIN}$** 

Calculate the minimum inductor value required for 500 mA or less peak-to-peak LED current ripple using [Equation 18](#).

$$L_{MIN} = \frac{(V_{IN} - V_{LED}) \times V_{LED}}{f_{SW} \times V_{IN} \times \Delta I_{L-PP}} = \frac{(48V - 35V) \times 35V}{500kHz \times 35V \times 500mA} = 37.9\mu H \quad (18)$$

Choose a higher standard value of  $L = 47\mu H$ .

**8.2.2.2.5 Calculate  $C_{IN-MIN}$** 

Calculate the minimum input capacitor value for 200 mV or less input voltage ripple using [Equation 19](#).

$$C_{IN-MIN} = \frac{D \times (1 - D) \times I_{LED}}{f_{SW} \times \Delta V_{IN}} = \frac{0.73 \times (1 - 0.73) \times 1A}{500kHz \times 200mV} = 1.97\mu F \quad (19)$$

Choose a higher standard value of  $C_{IN} = 2.2\mu F$ .

**Table 3. Bill of Materials**

DESIGNATION	DESCRIPTION	PACKAGE	MANUFACTURE PART NO.	VENDOR
U1	LED Driver IC LM3414 / LM3414HV	SOIC-8	LM3414 / LM3414HV	TI
L <sub>1</sub>	Inductor 47 $\mu$ H	8 x 8 x 4.9 (mm)	MMD-08EZ-470M-SI	Mag.Layers
D <sub>1</sub>	Schottky Diode 100 V, 2 A	SMP	SS2PH10-M3	Vishay
C <sub>IN</sub>	Cap MLCC 100V 2.2 $\mu$ F X7R	1210	GRM32ER72A225KA35L	Murata
C <sub>VCC</sub>	Cap MLCC 16V 1 $\mu$ F X5R	603	GRM39X5R105K16D52K	Murata
R <sub>IADJ</sub>	Chip Resistor 3.24 k $\Omega$ 1%	603	CRCW06033241F	Vishay
R <sub>FS</sub>	Chip Resistor 40.2 k $\Omega$ 1%	603	CRCW06034022F	Vishay

### 8.2.2.3 Application Curve

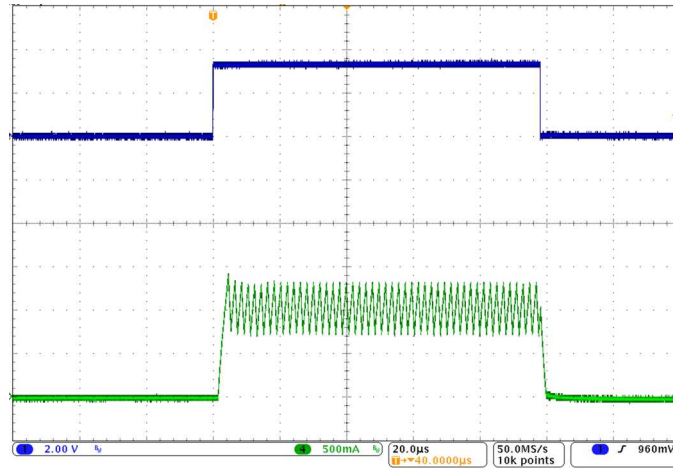

Figure 24. PWM Dimming Top = DIM. Bottom = LED Current.

## 9 Power Supply Recommendations

Use any DC output power supply with a maximum voltage high enough for the application. The power supply should have a minimum current limit of at least 1 A.

## 10 Layout

### 10.1 Layout Guidelines

Discontinuous currents are the most likely to generate EMI; therefore, take care when routing these paths. The main path for discontinuous current in the LM3414/HV buck converter contains the input capacitor ( $C_{IN}$ ), the recirculating diode (D1), and the switch node (LX). This loop should be kept as small as possible and the connections between all three components should be short and thick to minimize parasitic inductance. In particular, the switch node (where L1, D1 and LX connect) should be just large enough to connect the components without excessive heating from the current it carries.

The IADJ, FS, and DIM pins are all high-impedance control inputs which couple external noise easily, therefore the loops containing these high impedance nodes should be minimized. The frequency setting resistor ( $R_{FS}$ ) and current setting resistor ( $R_{IADJ}$ ) should be placed close to the FS and IADJ pins as possible.

### 10.2 Layout Example

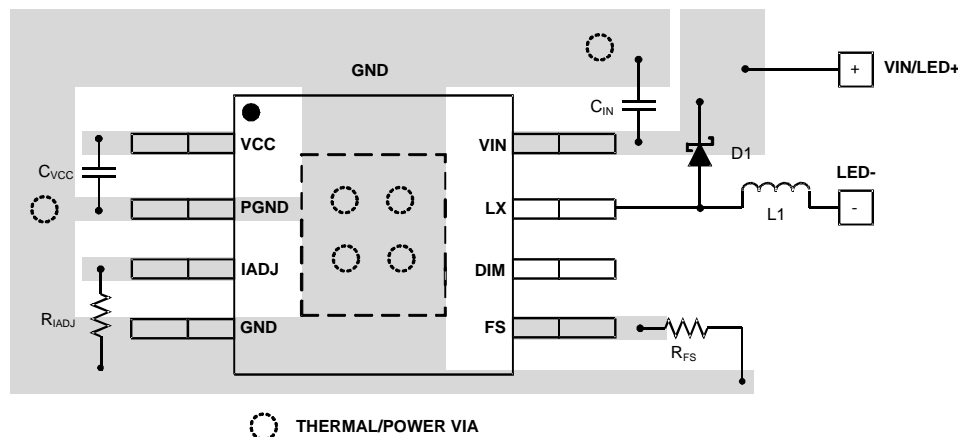

**Figure 25. Layout Recommendation**

## 11 Device and Documentation Support

### 11.1 Related Links

The table below lists quick access links. Categories include technical documents, support and community resources, tools and software, and quick access to sample or buy.

**Table 4. Related Links**

PARTS	PRODUCT FOLDER	SAMPLE AND BUY	TECHNICAL DOCUMENTS	TOOLS AND SOFTWARE	SUPPORT AND COMMUNITY
LM3414	<a href="#">Click here</a>	<a href="#">Click here</a>	<a href="#">Click here</a>	<a href="#">Click here</a>	<a href="#">Click here</a>
LM3414HV	<a href="#">Click here</a>	<a href="#">Click here</a>	<a href="#">Click here</a>	<a href="#">Click here</a>	<a href="#">Click here</a>

### 11.2 Community Resources

The following links connect to TI community resources. Linked contents are provided "AS IS" by the respective contributors. They do not constitute TI specifications and do not necessarily reflect TI's views; see TI's [Terms of Use](#).

**TI E2E™ Online Community** *TI's Engineer-to-Engineer (E2E) Community*. Created to foster collaboration among engineers. At [e2e.ti.com](http://e2e.ti.com), you can ask questions, share knowledge, explore ideas and help solve problems with fellow engineers.

**Design Support** *TI's Design Support* Quickly find helpful E2E forums along with design support tools and contact information for technical support.

### 11.3 Trademarks

E2E is a trademark of Texas Instruments.  
 All other trademarks are the property of their respective owners.

### 11.4 Electrostatic Discharge Caution



These devices have limited built-in ESD protection. The leads should be shorted together or the device placed in conductive foam during storage or handling to prevent electrostatic damage to the MOS gates.

### 11.5 Glossary

**SLYZ022** — *TI Glossary*.

This glossary lists and explains terms, acronyms, and definitions.

## 12 Mechanical, Packaging, and Orderable Information

The following pages include mechanical, packaging, and orderable information. This information is the most current data available for the designated devices. This data is subject to change without notice and revision of this document. For browser-based versions of this data sheet, refer to the left-hand navigation.

**PACKAGING INFORMATION**

Orderable Device	Status (1)	Package Type	Package Drawing	Pins	Package Qty	Eco Plan (2)	Lead/Ball Finish (6)	MSL Peak Temp (3)	Op Temp (°C)	Device Marking (4/5)	Samples
LM3414HVMR/NOPB	ACTIVE	SO PowerPAD	DDA	8	95	Green (RoHS & no Sb/Br)	CU SN	Level-3-260C-168 HR	-40 to 125	L3414 HVMR	<a href="#">Samples</a>
LM3414HVMRX/NOPB	ACTIVE	SO PowerPAD	DDA	8	2500	Green (RoHS & no Sb/Br)	CU SN	Level-3-260C-168 HR	-40 to 125	L3414 HVMR	<a href="#">Samples</a>
LM3414HVSD/NOPB	ACTIVE	WSON	NGQ	8	1000	Green (RoHS & no Sb/Br)	CU SN	Level-1-260C-UNLIM	-40 to 125	L249B	<a href="#">Samples</a>
LM3414HVSDX/NOPB	ACTIVE	WSON	NGQ	8	4500	Green (RoHS & no Sb/Br)	CU SN	Level-1-260C-UNLIM	-40 to 125	L249B	<a href="#">Samples</a>
LM3414MR/NOPB	ACTIVE	SO PowerPAD	DDA	8	95	Green (RoHS & no Sb/Br)	CU SN	Level-3-260C-168 HR	-40 to 125	L3414 MR	<a href="#">Samples</a>
LM3414MRX/NOPB	ACTIVE	SO PowerPAD	DDA	8	2500	Green (RoHS & no Sb/Br)	CU SN	Level-3-260C-168 HR	-40 to 125	L3414 MR	<a href="#">Samples</a>
LM3414SD/NOPB	ACTIVE	WSON	NGQ	8	1000	Green (RoHS & no Sb/Br)	CU SN	Level-1-260C-UNLIM	-40 to 125	L248B	<a href="#">Samples</a>
LM3414SDX/NOPB	ACTIVE	WSON	NGQ	8	4500	Green (RoHS & no Sb/Br)	CU SN	Level-1-260C-UNLIM	-40 to 125	L248B	<a href="#">Samples</a>

(1) The marketing status values are defined as follows:

**ACTIVE:** Product device recommended for new designs.

**LIFEBUY:** TI has announced that the device will be discontinued, and a lifetime-buy period is in effect.

**NRND:** Not recommended for new designs. Device is in production to support existing customers, but TI does not recommend using this part in a new design.

**PREVIEW:** Device has been announced but is not in production. Samples may or may not be available.

**OBSELETE:** TI has discontinued the production of the device.

(2) Eco Plan - The planned eco-friendly classification: Pb-Free (RoHS), Pb-Free (RoHS Exempt), or Green (RoHS & no Sb/Br) - please check <http://www.ti.com/productcontent> for the latest availability information and additional product content details.

**TBD:** The Pb-Free/Green conversion plan has not been defined.

**Pb-Free (RoHS):** TI's terms "Lead-Free" or "Pb-Free" mean semiconductor products that are compatible with the current RoHS requirements for all 6 substances, including the requirement that lead not exceed 0.1% by weight in homogeneous materials. Where designed to be soldered at high temperatures, TI Pb-Free products are suitable for use in specified lead-free processes.

**Pb-Free (RoHS Exempt):** This component has a RoHS exemption for either 1) lead-based flip-chip solder bumps used between the die and package, or 2) lead-based die adhesive used between the die and leadframe. The component is otherwise considered Pb-Free (RoHS compatible) as defined above.

**Green (RoHS & no Sb/Br):** TI defines "Green" to mean Pb-Free (RoHS compatible), and free of Bromine (Br) and Antimony (Sb) based flame retardants (Br or Sb do not exceed 0.1% by weight in homogeneous material)

(3) MSL, Peak Temp. - The Moisture Sensitivity Level rating according to the JEDEC industry standard classifications, and peak solder temperature.

(4) There may be additional marking, which relates to the logo, the lot trace code information, or the environmental category on the device.

(5) Multiple Device Markings will be inside parentheses. Only one Device Marking contained in parentheses and separated by a "~" will appear on a device. If a line is indented then it is a continuation of the previous line and the two combined represent the entire Device Marking for that device.

(6) Lead/Ball Finish - Orderable Devices may have multiple material finish options. Finish options are separated by a vertical ruled line. Lead/Ball Finish values may wrap to two lines if the finish value exceeds the maximum column width.

**Important Information and Disclaimer:**The information provided on this page represents TI's knowledge and belief as of the date that it is provided. TI bases its knowledge and belief on information provided by third parties, and makes no representation or warranty as to the accuracy of such information. Efforts are underway to better integrate information from third parties. TI has taken and continues to take reasonable steps to provide representative and accurate information but may not have conducted destructive testing or chemical analysis on incoming materials and chemicals. TI and TI suppliers consider certain information to be proprietary, and thus CAS numbers and other limited information may not be available for release.

In no event shall TI's liability arising out of such information exceed the total purchase price of the TI part(s) at issue in this document sold by TI to Customer on an annual basis.

## TAPE AND REEL INFORMATION



### QUADRANT ASSIGNMENTS FOR PIN 1 ORIENTATION IN TAPE



\*All dimensions are nominal

Device	Package Type	Package Drawing	Pins	SPQ	Reel Diameter (mm)	Reel Width W1 (mm)	A0 (mm)	B0 (mm)	K0 (mm)	P1 (mm)	W (mm)	Pin1 Quadrant
LM3414HVMRX/NOPB	SO Power PAD	DDA	8	2500	330.0	12.4	6.5	5.4	2.0	8.0	12.0	Q1
LM3414HVSD/NOPB	WSON	NGQ	8	1000	178.0	12.4	3.3	3.3	1.0	8.0	12.0	Q1
LM3414HVSDX/NOPB	WSON	NGQ	8	4500	330.0	12.4	3.3	3.3	1.0	8.0	12.0	Q1
LM3414MRX/NOPB	SO Power PAD	DDA	8	2500	330.0	12.4	6.5	5.4	2.0	8.0	12.0	Q1
LM3414SD/NOPB	WSON	NGQ	8	1000	178.0	12.4	3.3	3.3	1.0	8.0	12.0	Q1
LM3414SDX/NOPB	WSON	NGQ	8	4500	330.0	12.4	3.3	3.3	1.0	8.0	12.0	Q1

**TAPE AND REEL BOX DIMENSIONS**

\*All dimensions are nominal

Device	Package Type	Package Drawing	Pins	SPQ	Length (mm)	Width (mm)	Height (mm)
LM3414HVMRX/NOPB	SO PowerPAD	DDA	8	2500	367.0	367.0	35.0
LM3414HVSD/NOPB	WSON	NGQ	8	1000	210.0	185.0	35.0
LM3414HVSDX/NOPB	WSON	NGQ	8	4500	367.0	367.0	35.0
LM3414MRX/NOPB	SO PowerPAD	DDA	8	2500	367.0	367.0	35.0
LM3414SD/NOPB	WSON	NGQ	8	1000	210.0	185.0	35.0
LM3414SDX/NOPB	WSON	NGQ	8	4500	367.0	367.0	35.0

# DDA0008A

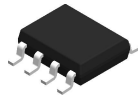

# PACKAGE OUTLINE

## PowerPAD™ SOIC - 1.7 mm max height

PLASTIC SMALL OUTLINE

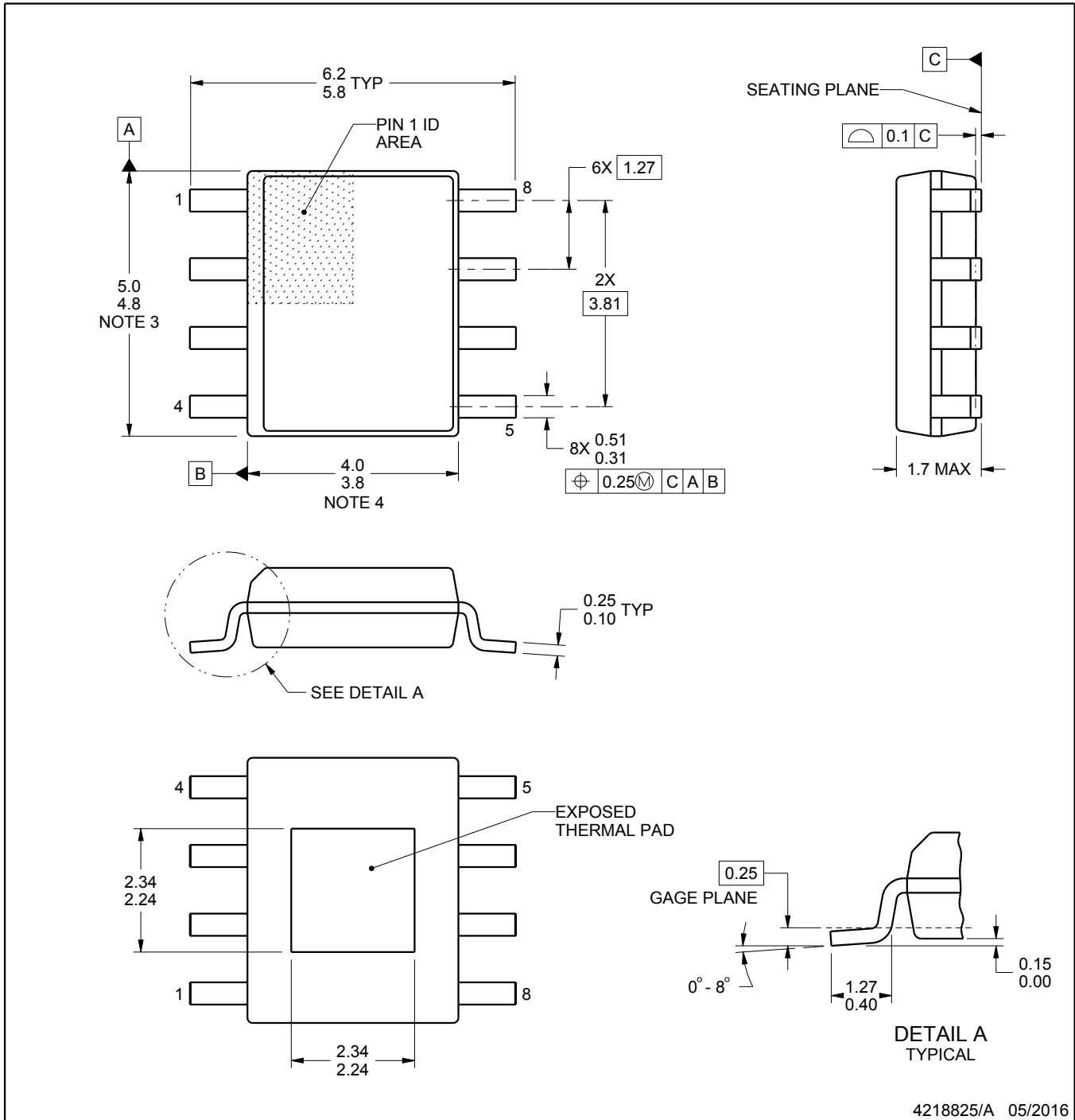

4218825/A 05/2016

PowerPAD is a trademark of Texas Instruments.

### NOTES:

1. All linear dimensions are in millimeters. Any dimensions in parenthesis are for reference only. Dimensioning and tolerancing per ASME Y14.5M.
2. This drawing is subject to change without notice.
3. This dimension does not include mold flash, protrusions, or gate burrs. Mold flash, protrusions, or gate burrs shall not exceed 0.15 mm per side.
4. This dimension does not include interlead flash. Interlead flash shall not exceed 0.25 mm per side.
5. Reference JEDEC registration MS-012.

# EXAMPLE BOARD LAYOUT

DDA0008A

PowerPAD™ SOIC - 1.7 mm max height

PLASTIC SMALL OUTLINE

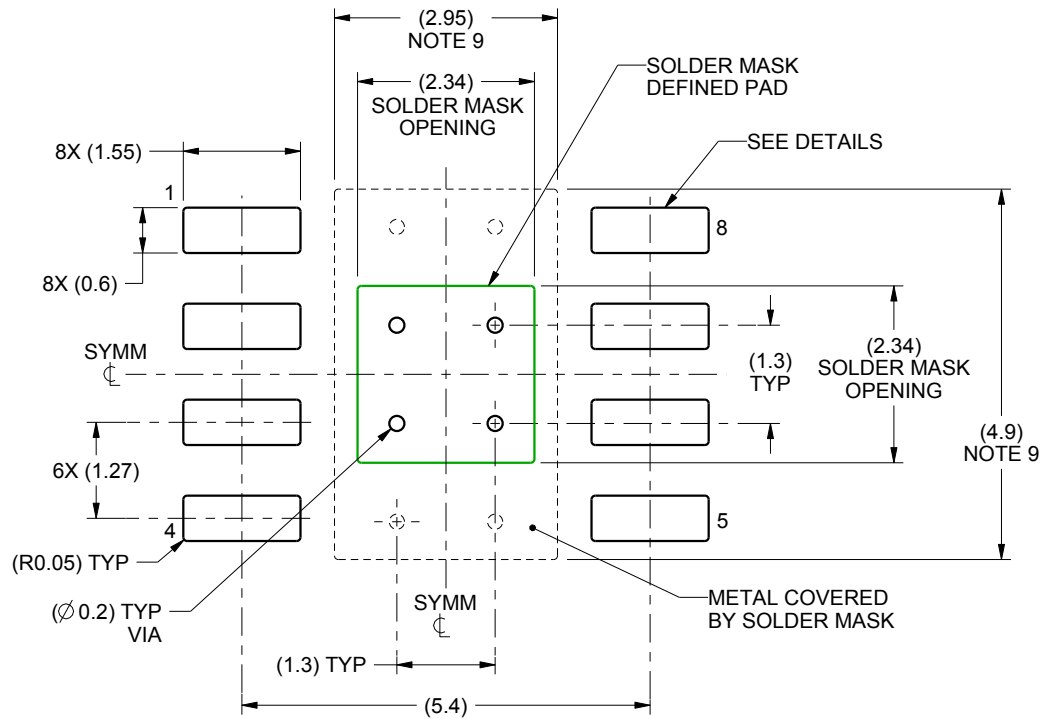

LAND PATTERN EXAMPLE  
SCALE:10X

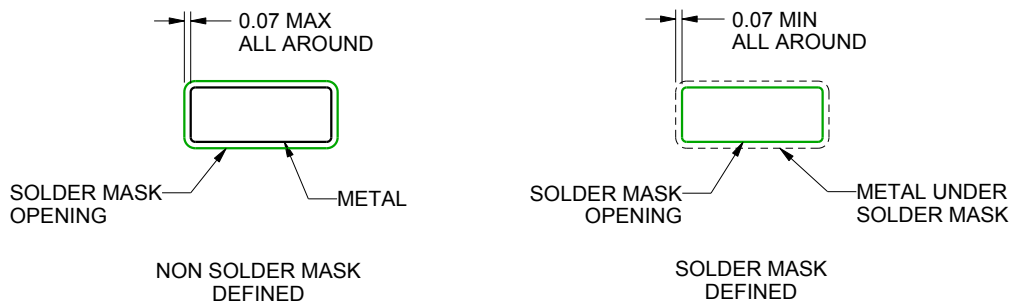

SOLDER MASK DETAILS

4218825/A 05/2016

NOTES: (continued)

6. Publication IPC-7351 may have alternate designs.
7. Solder mask tolerances between and around signal pads can vary based on board fabrication site.
8. This package is designed to be soldered to a thermal pad on the board. For more information, see Texas Instruments literature numbers SLMA002 ([www.ti.com/lit/slma002](http://www.ti.com/lit/slma002)) and SLMA004 ([www.ti.com/lit/slma004](http://www.ti.com/lit/slma004)).
9. Size of metal pad may vary due to creepage requirement.
10. Vias are optional depending on application, refer to device data sheet. If any vias are implemented, refer to their locations shown on this view. It is recommended that vias under paste be filled, plugged or tented.

# EXAMPLE STENCIL DESIGN

DDA0008A

PowerPAD™ SOIC - 1.7 mm max height

PLASTIC SMALL OUTLINE

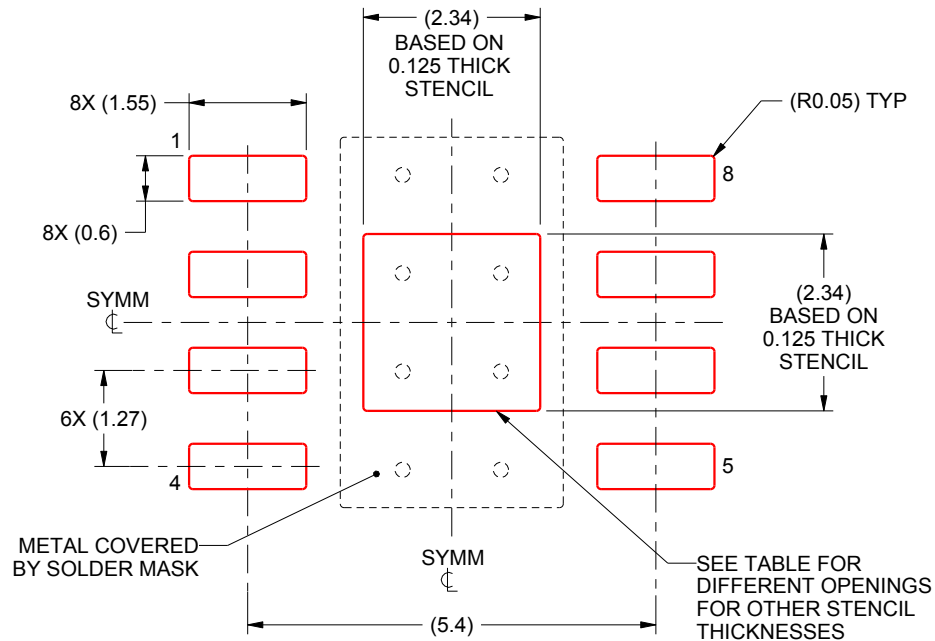

SOLDER PASTE EXAMPLE  
 EXPOSED PAD  
 100% PRINTED SOLDER COVERAGE BY AREA  
 SCALE:10X

STENCIL THICKNESS	SOLDER STENCIL OPENING
0.1	2.62 X 2.62
0.125	2.34 X 2.34 (SHOWN)
0.150	2.14 X 2.14
0.175	1.98 X 1.98

4218825/A 05/2016

NOTES: (continued)

11. Laser cutting apertures with trapezoidal walls and rounded corners may offer better paste release. IPC-7525 may have alternate design recommendations.
12. Board assembly site may have different recommendations for stencil design.

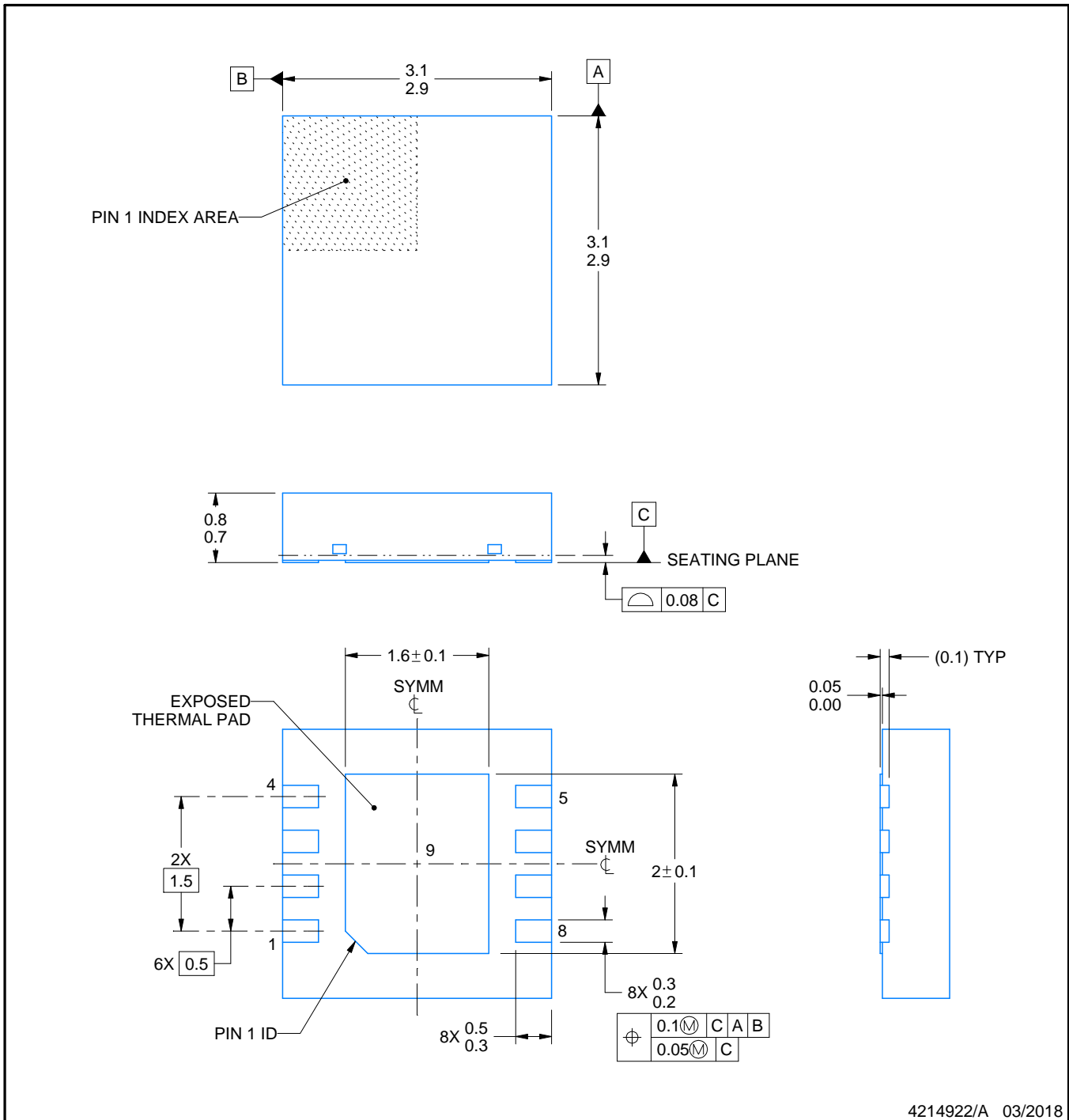
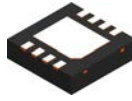

4214922/A 03/2018

NOTES:

1. All linear dimensions are in millimeters. Any dimensions in parenthesis are for reference only. Dimensioning and tolerancing per ASME Y14.5M.
2. This drawing is subject to change without notice.
3. The package thermal pad must be soldered to the printed circuit board for thermal and mechanical performance.

# EXAMPLE BOARD LAYOUT

NGQ0008A

WSON - 0.8 mm max height

PLASTIC SMALL OUTLINE - NO LEAD

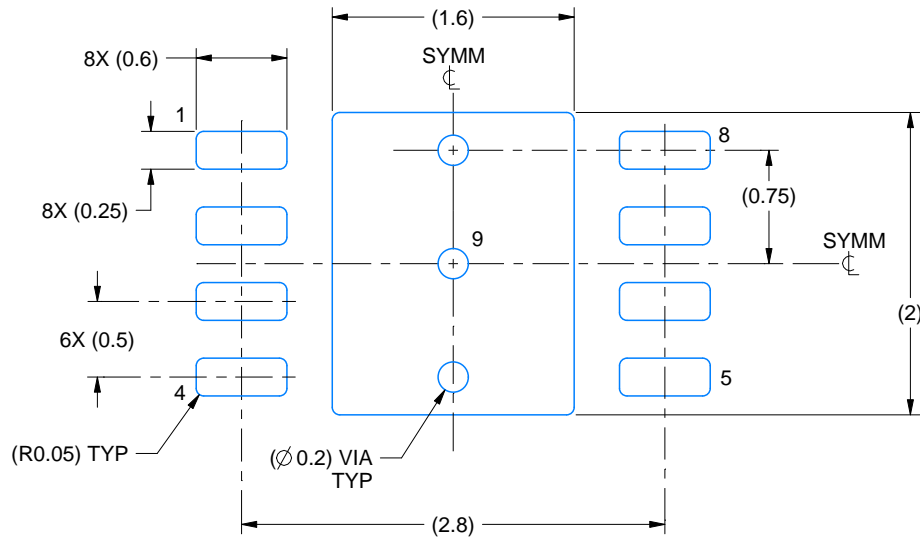

LAND PATTERN EXAMPLE  
EXPOSED METAL SHOWN  
SCALE:20X

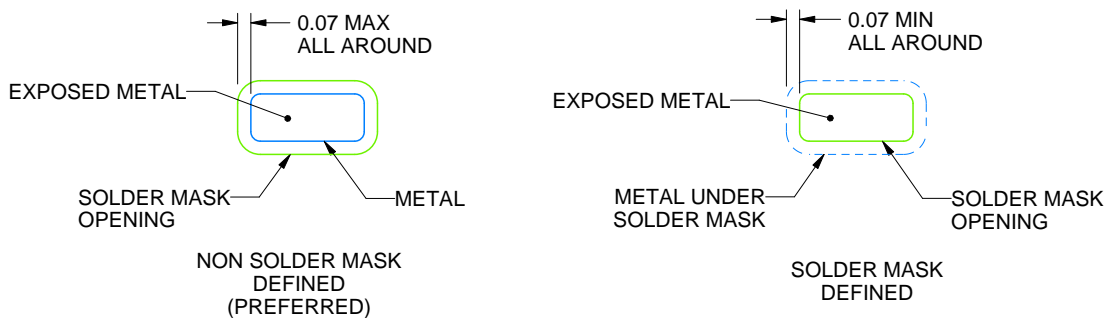

SOLDER MASK DETAILS

4214922/A 03/2018

NOTES: (continued)

- This package is designed to be soldered to a thermal pad on the board. For more information, see Texas Instruments literature number SLUA271 ([www.ti.com/lit/sluea271](http://www.ti.com/lit/sluea271)).
- Vias are optional depending on application, refer to device data sheet. If any vias are implemented, refer to their locations shown on this view. It is recommended that vias under paste be filled, plugged or tented.

# EXAMPLE STENCIL DESIGN

NGQ0008A

WSON - 0.8 mm max height

PLASTIC SMALL OUTLINE - NO LEAD

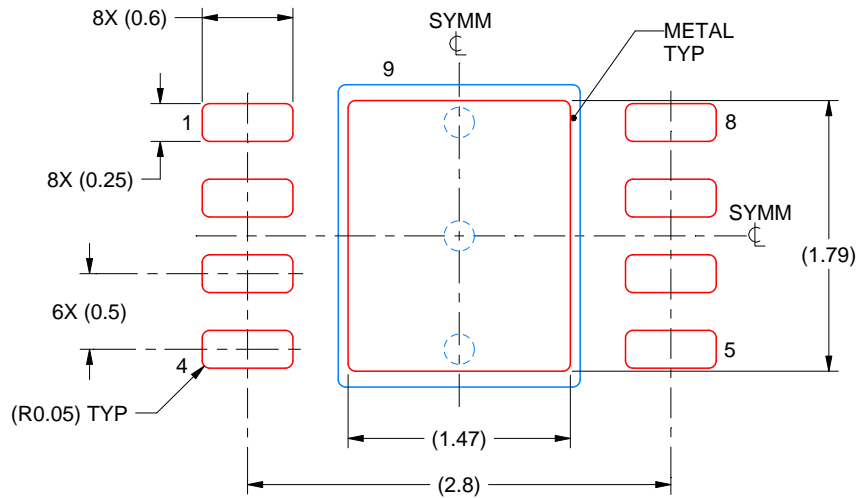

SOLDER PASTE EXAMPLE  
BASED ON 0.1 mm THICK STENCIL

EXPOSED PAD 9:  
82% PRINTED SOLDER COVERAGE BY AREA UNDER PACKAGE  
SCALE:20X

4214922/A 03/2018

NOTES: (continued)

6. Laser cutting apertures with trapezoidal walls and rounded corners may offer better paste release. IPC-7525 may have alternate design recommendations.

## IMPORTANT NOTICE AND DISCLAIMER

TI PROVIDES TECHNICAL AND RELIABILITY DATA (INCLUDING DATASHEETS), DESIGN RESOURCES (INCLUDING REFERENCE DESIGNS), APPLICATION OR OTHER DESIGN ADVICE, WEB TOOLS, SAFETY INFORMATION, AND OTHER RESOURCES "AS IS" AND WITH ALL FAULTS, AND DISCLAIMS ALL WARRANTIES, EXPRESS AND IMPLIED, INCLUDING WITHOUT LIMITATION ANY IMPLIED WARRANTIES OF MERCHANTABILITY, FITNESS FOR A PARTICULAR PURPOSE OR NON-INFRINGEMENT OF THIRD PARTY INTELLECTUAL PROPERTY RIGHTS.

These resources are intended for skilled developers designing with TI products. You are solely responsible for (1) selecting the appropriate TI products for your application, (2) designing, validating and testing your application, and (3) ensuring your application meets applicable standards, and any other safety, security, or other requirements. These resources are subject to change without notice. TI grants you permission to use these resources only for development of an application that uses the TI products described in the resource. Other reproduction and display of these resources is prohibited. No license is granted to any other TI intellectual property right or to any third party intellectual property right. TI disclaims responsibility for, and you will fully indemnify TI and its representatives against, any claims, damages, costs, losses, and liabilities arising out of your use of these resources.

TI's products are provided subject to TI's Terms of Sale ([www.ti.com/legal/termsofsale.html](http://www.ti.com/legal/termsofsale.html)) or other applicable terms available either on [ti.com](http://ti.com) or provided in conjunction with such TI products. TI's provision of these resources does not expand or otherwise alter TI's applicable warranties or warranty disclaimers for TI products.

Mailing Address: Texas Instruments, Post Office Box 655303, Dallas, Texas 75265  
Copyright © 2019, Texas Instruments Incorporated

## Looking for pricing, stock, or lifecycle information?

Click below to explore more details on WIN SOURCE:

 [View LM3414HVMR/NOPB on WIN SOURCE](#)

 [Texas Instruments](#) Information

## Optimize Your Supply Chain with WIN SOURCE Solutions

-  Global Sourcing Solution
-  Obsolete Management
-  Cost Control Management
-  Shortage Management
-  Alternative Solution
-  Excess Inventory Management