



# THE DATASHEET OF LM3405XMKX/NOPB



## LM3405 1.6-MHz, 1-A Constant Current Buck Regulator For Powering LEDs

### 1 Features

- $V_{IN}$  Operating Range of 3 V to 15 V
- Drives up to 5 High-Brightness LEDs in Series at 1 A
- Thin SOT-6 Package
- 1.6-MHz Switching Frequency
- EN/DIM Input for Enabling and PWM Dimming of LEDs
- 300-m $\Omega$  NMOS Switch
- 40-nA Shutdown Current at  $V_{IN} = 5$  V
- Internally Compensated Current-mode Control
- Cycle-by-Cycle Current Limit
- Input Voltage UVLO
- Overcurrent Protection
- Thermal Shutdown

### 2 Applications

- LED Drivers
- Constant Current Sources
- Industrial Lighting
- LED Flashlights

### 3 Description

The LM3405 is a 1-A constant current buck LED driver designed to provide a simple, high efficiency solution for driving high power LEDs. With a 0.205-V reference voltage feedback control to minimize power dissipation, an external resistor sets the current as required for driving various types of LEDs. Switching frequency is internally set to 1.6 MHz, allowing small surface mount inductors and capacitors to be used. The LM3405 uses current-mode control and internal compensation offering ease of use and predictable, high performance regulation over a wide range of operating conditions. With a maximum input voltage of 15 V, the device can drive up to 3 High-Brightness LEDs in series at 1-A forward current, with the single LED forward voltage of approximately 3.7 V. Additional features include user accessible EN/DIM pin for enabling and PWM dimming of LEDs, thermal shutdown, cycle-by-cycle current limit and overcurrent protection.

#### Device Information<sup>(1)</sup>

PART NUMBER	PACKAGE	BODY SIZE (NOM)
LM3405	SOT (6)	2.90 mm x 1.60 mm

(1) For all available packages, see the orderable addendum at the end of the data sheet.

#### Typical Application Circuit

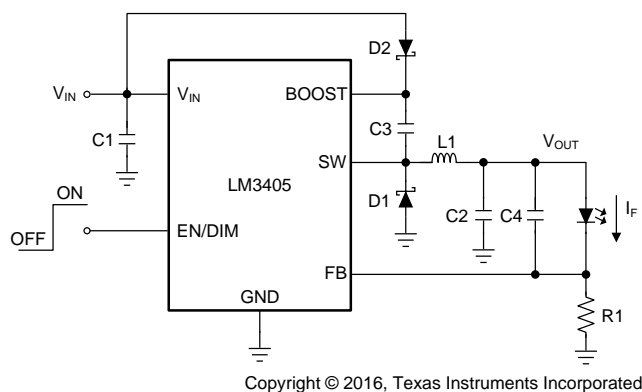

#### Efficiency vs LED Current ( $V_{IN} = 5$ V)

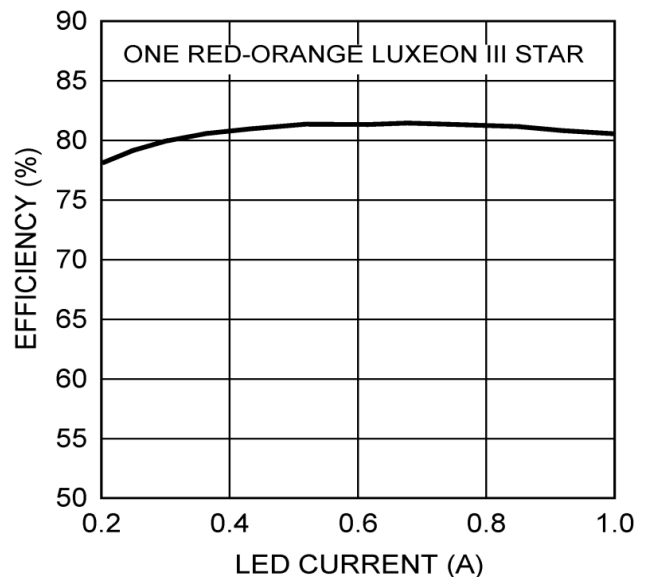

## Table of Contents

<b>1 Features</b> ..... 1 <b>2 Applications</b> ..... 1 <b>3 Description</b> ..... 1 <b>4 Revision History</b> ..... 2 <b>5 Pin Configuration and Functions</b> ..... 3 <b>6 Specifications</b> ..... 4 6.1 Absolute Maximum Ratings ..... 4 6.2 ESD Ratings ..... 4 6.3 Recommended Operating Conditions ..... 4 6.4 Thermal Information ..... 5 6.5 Electrical Characteristics ..... 5 6.6 Typical Characteristics ..... 6 <b>7 Detailed Description</b> ..... 8 7.1 Overview ..... 8 7.2 Functional Block Diagram ..... 9 7.3 Feature Description ..... 9 7.4 Device Functional Modes ..... 14	<b>8 Application and Implementation</b> ..... 15 8.1 Application Information ..... 15 8.2 Typical Applications ..... 19 8.3 System Examples ..... 21 <b>9 Power Supply Recommendations</b> ..... 24 <b>10 Layout</b> ..... 24 10.1 Layout Guidelines ..... 24 10.2 Layout Example ..... 24 <b>11 Device and Documentation Support</b> ..... 25 11.1 Documentation Support ..... 25 11.2 Receiving Notification of Documentation Updates ..... 25 11.3 Community Resource ..... 25 11.4 Trademarks ..... 25 11.5 Electrostatic Discharge Caution ..... 25 11.6 Glossary ..... 25 <b>12 Mechanical, Packaging, and Orderable Information</b> ..... 25
---	--

## 4 Revision History

NOTE: Page numbers for previous revisions may differ from page numbers in the current version.

Changes from Revision B (April 2013) to Revision C	Page
• Added <i>ESD Ratings</i> table, <i>Feature Description</i> section, <i>Device Functional Modes</i> , <i>Application and Implementation</i> section, <i>Power Supply Recommendations</i> section, <i>Layout</i> section, <i>Device and Documentation Support</i> section, and <i>Mechanical, Packaging, and Orderable Information</i> section .....	1
• Deleted Soldering information (220°C, maximum) from <i>Absolute Maximum Ratings</i> .....	4
• Changed Thermal resistance, $\theta_{JA}$ , in <i>Thermal Information</i> From: 118°C/W To: 182.9°C/W .....	5

Changes from Revision A (May 2013) to Revision B	Page
• Changed layout of National Semiconductor Data Sheet to TI format .....	23

## 5 Pin Configuration and Functions

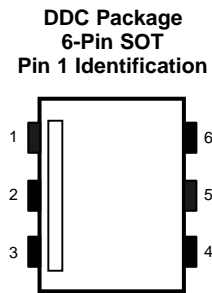
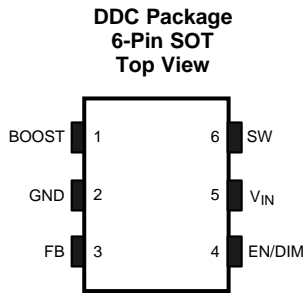

### Pin Functions

PIN		I/O	DESCRIPTION
NO.	NAME		
1	BOOST	O	Boost voltage that drives the NMOS output switch. A bootstrap capacitor is connected between the BOOST and SW pins.
2	GND	—	Signal and power ground pin. Place the bottom resistor of the feedback network as close as possible to this pin.
3	FB	I	Feedback pin. Connect FB to the LED string cathode and an external resistor to ground to set the LED current.
4	EN/DIM	I	Enable control input. Logic high enables operation. Toggling this pin with a periodic logic square wave of varying duty cycle at different frequencies controls the brightness of LEDs. Do not allow this pin to float or be greater than $V_{IN} + 0.3$ V.
5	VIN	I	Input supply voltage. Connect a bypass capacitor locally from this pin to GND.
6	SW	O	Switch pin. Connect this pin to the inductor, catch diode, and bootstrap capacitor.

## 6 Specifications

### 6.1 Absolute Maximum Ratings

over operating free-air temperature range (unless otherwise noted)<sup>(1)</sup>

	MIN	MAX	UNIT
Input voltage, $V_{IN}$	-0.5	20	V
SW voltage	-0.5	20	V
Boost voltage	-0.5	26	V
Boost to SW voltage	-0.5	6	V
FB voltage	-0.5	3	V
EN/DIM voltage	-0.5	$(V_{IN} + 0.3)$	V
Junction temperature, $T_J$		150	°C
Storage temperature, $T_{stg}$	-65	150	°C

- (1) Stresses beyond those listed under *Absolute Maximum Ratings* may cause permanent damage to the device. These are stress ratings only, which do not imply functional operation of the device at these or any other conditions beyond those indicated under *Recommended Operating Conditions*. Exposure to absolute-maximum-rated conditions for extended periods may affect device reliability.

### 6.2 ESD Ratings

		VALUE	UNIT
$V_{(ESD)}$ Electrostatic discharge	Human-body model (HBM), per ANSI/ESDA/JEDEC JS-001 <sup>(1)</sup>	±2000	V
	Charged-device model (CDM), per JEDEC specification JESD22-C101 <sup>(2)</sup>	±1000	

- (1) JEDEC document JEP155 states that 500-V HBM allows safe manufacturing with a standard ESD control process.  
 (2) JEDEC document JEP157 states that 250-V CDM allows safe manufacturing with a standard ESD control process.

### 6.3 Recommended Operating Conditions

	MIN	MAX	UNIT
Input voltage, $V_{IN}$	3	15	V
EN/DIM voltage	0	$(V_{IN} + 0.3)$	V
Boost to SW voltage	2.5	5.5	V
Junction temperature, $T_J$	-40	125	°C

## 6.4 Thermal Information

THERMAL METRIC <sup>(1)</sup>		LM3405	
		DDC (SOT)	
		6 PINS	
			UNIT
$R_{\theta JA}$	Junction-to-ambient thermal resistance	182.9	°C/W
$R_{\theta JC(top)}$	Junction-to-case (top) thermal resistance	53.4	°C/W
$R_{\theta JB}$	Junction-to-board thermal resistance	28.1	°C/W
$\Psi_{JT}$	Junction-to-top characterization parameter	1.2	°C/W
$\Psi_{JB}$	Junction-to-board characterization parameter	27.7	°C/W
$R_{\theta JC(bot)}$	Junction-to-case (bottom) thermal resistance	—	°C/W

(1) For more information about traditional and new thermal metrics, see the [Semiconductor and IC Package Thermal Metrics](#) application report.

## 6.5 Electrical Characteristics

$V_{IN} = 12\text{ V}$ , typical values are for  $T_J = 25^\circ\text{C}$  only; minimum and maximum limits apply over the junction temperature ( $T_J$ ) range of  $-40^\circ\text{C}$  to  $125^\circ\text{C}$  (unless otherwise noted). Typical values represent the most likely parametric norm, and are provided for reference purposes only.

PARAMETER		TEST CONDITIONS	MIN	TYP	MAX	UNIT
$V_{FB}$	Feedback voltage		0.188	0.205	0.22	V
$\Delta V_{FB}/(\Delta V_{IN} \times V_{FB})$	Feedback voltage line regulation	$V_{IN} = 3\text{ V}$ to $15\text{ V}$		0.01%		V
$I_{FB}$	Feedback input bias current	Sink or source		10	250	nA
UVLO	Undervoltage lockout	$V_{IN}$ rising		2.74	2.95	V
		$V_{IN}$ falling	1.9	2.3		
	UVLO hysteresis			0.44		V
$f_{SW}$	Switching frequency		1.2	1.6	1.9	MHz
$D_{MAX}$	Maximum duty cycle	$V_{FB} = 0\text{ V}$	85%	94%		
$R_{DS(ON)}$	Switch ON resistance	$V_{BOOST} - V_{SW} = 3\text{ V}$		300	600	m $\Omega$
$I_{CL}$	Switch current limit	$V_{BOOST} - V_{SW} = 3\text{ V}$ , $V_{IN} = 3\text{ V}$	1.2	2	2.8	A
$I_Q$	Quiescent current	Switching, $V_{FB} = 0.195\text{ V}$		1.8	2.8	mA
	Quiescent current (shutdown)	$V_{EN/DIM} = 0\text{ V}$		0.3		
$V_{EN/DIM\_TH}$	Enable threshold voltage	$V_{EN/DIM}$ rising	1.8			V
	Shutdown threshold voltage	$V_{EN/DIM}$ falling			0.4	V
$I_{EN/DIM}$	EN/DIM pin current	Sink or source		0.01		$\mu\text{A}$
$I_{SW}$	Switch leakage	$V_{IN} = 15\text{ V}$		0.1		$\mu\text{A}$

### 6.6 Typical Characteristics

$V_{IN} = 12\text{ V}$ ,  $V_{BOOST} - V_{SW} = 5\text{ V}$ , and  $T_A = 25^\circ\text{C}$  (unless otherwise noted).

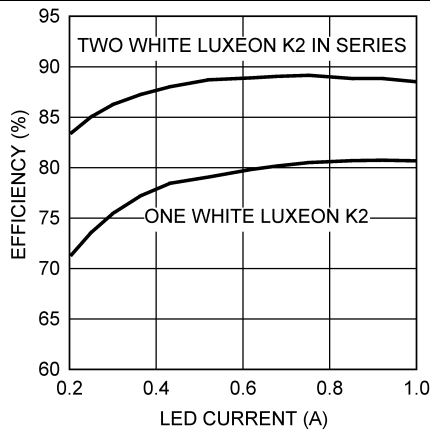
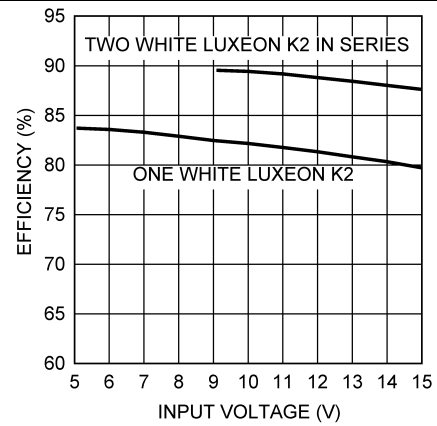
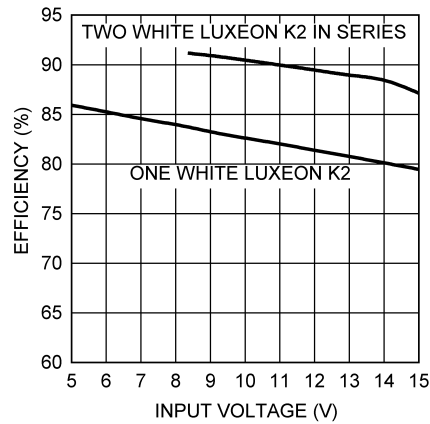

Figure 1. Efficiency vs LED Current



$I_F = 1\text{ A}$

Figure 2. Efficiency vs Input Voltage



$I_F = 0.7\text{ A}$

Figure 3. Efficiency vs Input Voltage

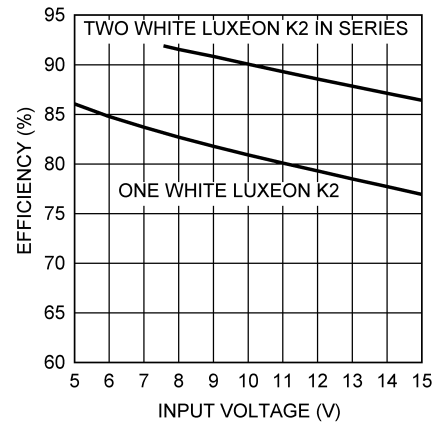

$I_F = 0.35\text{ A}$

Figure 4. Efficiency vs Input Voltage

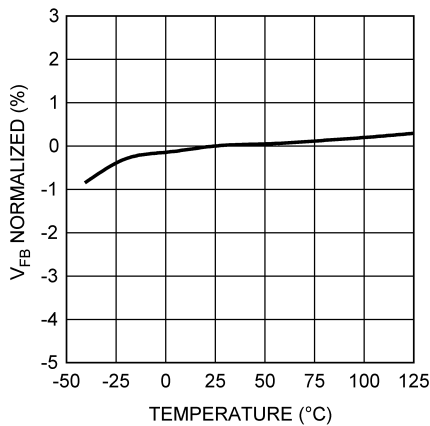

Figure 5.  $V_{FB}$  vs Temperature

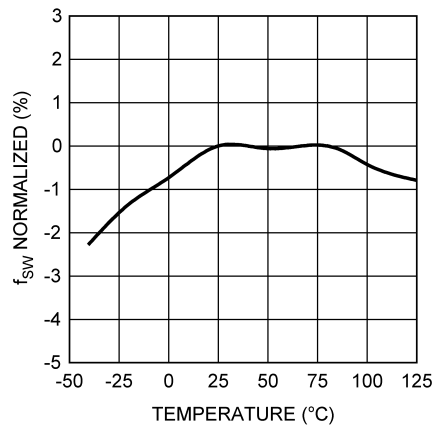

Figure 6. Oscillator Frequency vs Temperature

Typical Characteristics (continued)

$V_{IN} = 12\text{ V}$ ,  $V_{BOOST} - V_{SW} = 5\text{ V}$ , and  $T_A = 25^\circ\text{C}$  (unless otherwise noted).

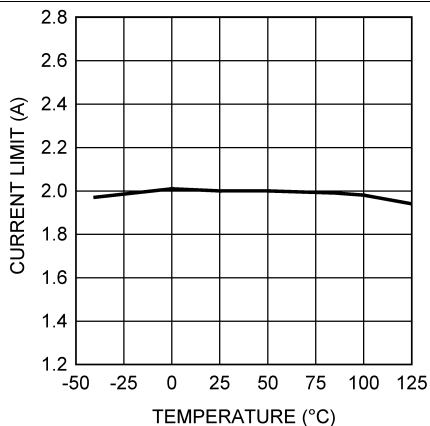
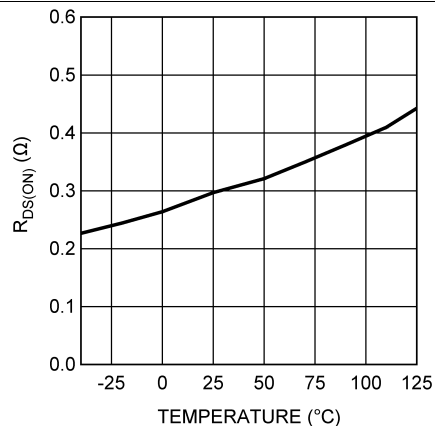

Figure 7. Current Limit vs Temperature



$V_{BOOST} - V_{SW} = 3\text{ V}$

Figure 8. SOT  $R_{DS(ON)}$  vs Temperature

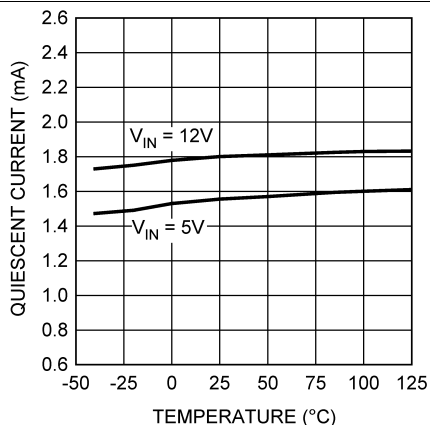
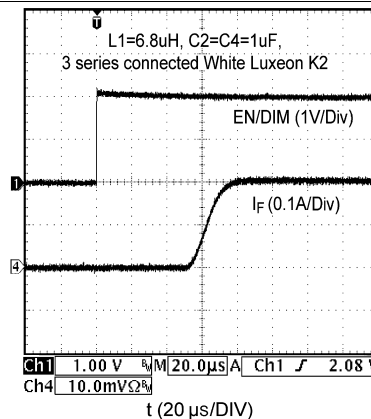

Figure 9. Quiescent Current vs Temperature



$V_{IN} = 15\text{ V}$   $I_F = 0.2\text{ A}$

Figure 10. Start-Up Response to EN/DIM Signal

## 7 Detailed Description

### 7.1 Overview

The LM3405 device is a PWM, current-mode controlled buck switching regulator designed to provide a simple, high efficiency solution for driving LEDs with a preset switching frequency of 1.6MHz. This high frequency allows the LM3405 to operate with small surface mount capacitors and inductors, resulting in LED drivers that only require a minimum amount of board space. The LM3405 is internally compensated, simple to use, and requires few external components.

The following sections refer to [Functional Block Diagram](#) and to the waveforms in [Figure 11](#). The LM3405 supplies a regulated output current by switching the internal NMOS power switch at constant frequency and variable duty cycle. A switching cycle begins at the falling edge of the reset pulse generated by the internal oscillator. When this pulse goes low, the output control logic turns on the internal NMOS power switch. During this on-time, the SW pin voltage ( $V_{SW}$ ) swings up to approximately  $V_{IN}$ , and the inductor current ( $I_L$ ) increases with a linear slope.  $I_L$  is measured by the current sense amplifier, which generates an output proportional to the switch current. The sense signal is summed with the regulator's corrective ramp and compared to the error amplifier's output, which is proportional to the difference between the feedback voltage and  $V_{REF}$ . When the PWM comparator output goes high, the internal power switch turns off until the next switching cycle begins. During the switch off-time, inductor current discharges through the catch diode D1, which forces the SW pin to swing below ground by the forward voltage ( $V_{D1}$ ) of the catch diode. The regulator loop adjusts the duty cycle ( $D$ ) to maintain a constant output current ( $I_F$ ) through the LED, by forcing FB pin voltage to be equal to  $V_{REF}$  (0.205 V).

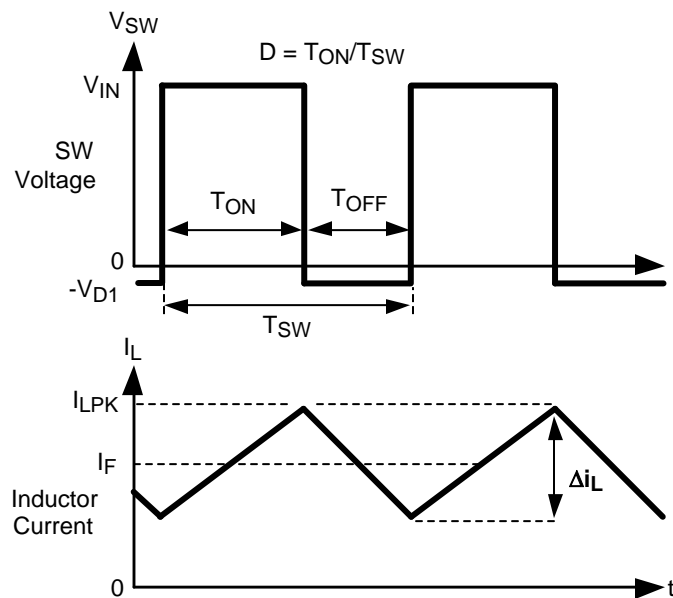

**Figure 11. SW Pin Voltage and Inductor Current Waveforms of LM3405**

## 7.2 Functional Block Diagram

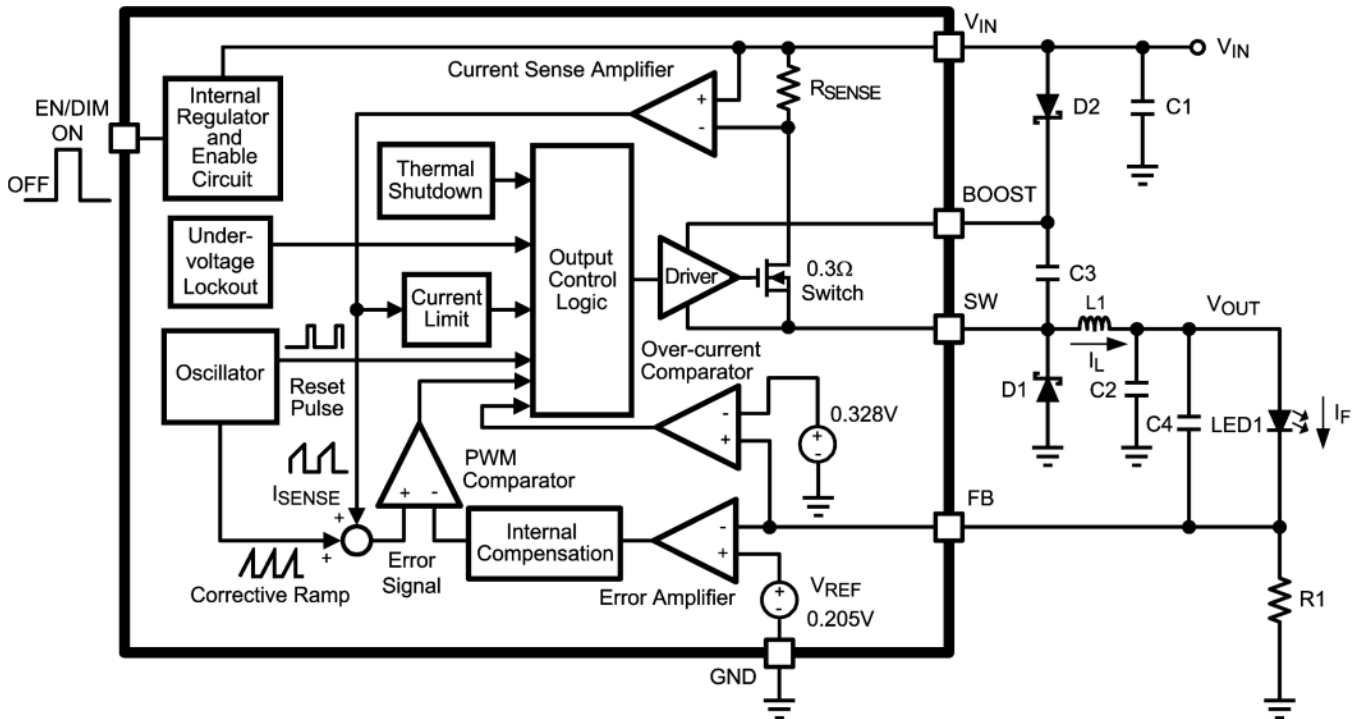

Copyright © 2016, Texas Instruments Incorporated

## 7.3 Feature Description

### 7.3.1 Boost Function

Capacitor C3 and diode D2 in the [Functional Block Diagram](#) are used to generate a voltage  $V_{BOOST}$ . The voltage across C3,  $V_{BOOST} - V_{SW}$ , is the gate drive voltage to the internal NMOS power switch. To properly drive the internal NMOS switch during its on-time,  $V_{BOOST}$  must be at least 2.5-V greater than  $V_{SW}$ . TI recommends a large value of  $V_{BOOST} - V_{SW}$  to achieve better efficiency by minimizing both the internal switch ON resistance ( $R_{DS(ON)}$ ) and the switch rise and fall times. However,  $V_{BOOST} - V_{SW}$  must not exceed the maximum operating limit of 5.5 V.

When the LM3405 starts up, internal circuitry from  $V_{IN}$  supplies a 20-mA current to the BOOST pin, flowing out of the BOOST pin into C3. This current charges C3 to a voltage sufficient to turn the switch on. The BOOST pin continues to source current to C3 until the voltage at the feedback pin is greater than 123 mV.

There are various methods to derive  $V_{BOOST}$ :

1. From the input voltage ( $V_{IN}$ )
2. From the output voltage ( $V_{OUT}$ )
3. From a shunt or series Zener diode
4. From an external distributed voltage rail ( $V_{EXT}$ )

The first method is shown in [Functional Block Diagram](#). Capacitor C3 is charged through diode D2 by  $V_{IN}$ . During a normal switching cycle, when the internal NMOS power switch is off,  $T_{OFF}$  (see [Figure 11](#)),  $V_{BOOST}$  equals  $V_{IN}$  minus the forward voltage of D2 ( $V_{D2}$ ), during which the current in the inductor (L1) forward biases the catch diode D1 ( $V_{D1}$ ). Therefore, the gate drive voltage stored across C3 is shown in [Equation 1](#).

$$V_{BOOST} - V_{SW} = V_{IN} - V_{D2} + V_{D1} \quad (1)$$

When the NMOS switch turns on ( $T_{ON}$ ), the switch pin rises to [Equation 2](#).

$$V_{SW} = V_{IN} - (R_{DS(ON)} \times I_L) \quad (2)$$

Because the voltage across C3 remains unchanged,  $V_{BOOST}$  is forced to rise thus reverse biasing D2. The voltage at  $V_{BOOST}$  is then calculated with [Equation 3](#).

**Feature Description (continued)**

$$V_{\text{BOOST}} = 2V_{\text{IN}} - (R_{\text{DS(ON)}} \times I_{\text{L}}) - V_{\text{D2}} + V_{\text{D1}} \tag{3}$$

Depending on the quality of the diodes D1 and D2, the gate drive voltage in this method can be slightly less or larger than the input voltage  $V_{\text{IN}}$ . For best performance, ensure that the variation of the input supply does not cause the gate drive voltage to fall outside the recommended range in [Equation 4](#).

$$2.5 \text{ V} < V_{\text{IN}} - V_{\text{D2}} + V_{\text{D1}} < 5.5 \text{ V} \tag{4}$$

The second method for deriving the boost voltage is to connect D2 to the output as shown in [Figure 12](#). The gate drive voltage in this configuration is shown in [Equation 5](#).

$$V_{\text{BOOST}} - V_{\text{SW}} = V_{\text{OUT}} - V_{\text{D2}} + V_{\text{D1}} \tag{5}$$

Because the gate drive voltage must be in the range of 2.5 V to 5.5 V, the output voltage  $V_{\text{OUT}}$  must be limited to a certain range. For the calculation of  $V_{\text{OUT}}$ , see [Output Voltage](#).

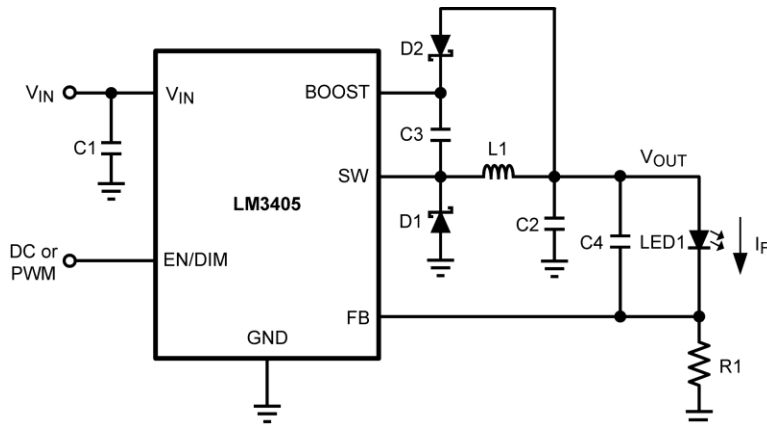

Copyright © 2016, Texas Instruments Incorporated

**Figure 12.  $V_{\text{BOOST}}$  Derived from  $V_{\text{OUT}}$**

The third method can be used in the applications where both  $V_{\text{IN}}$  and  $V_{\text{OUT}}$  are greater than 5.5 V. In these cases, C3 cannot be charged directly from these voltages; instead C3 can be charged from  $V_{\text{IN}}$  or  $V_{\text{OUT}}$  minus a Zener voltage ( $V_{\text{D3}}$ ) by placing a Zener diode D3 in series with D2 as shown in [Figure 13](#). When using a series Zener diode from the input, the gate drive voltage is  $V_{\text{IN}} - V_{\text{D3}} - V_{\text{D2}} + V_{\text{D1}}$ .

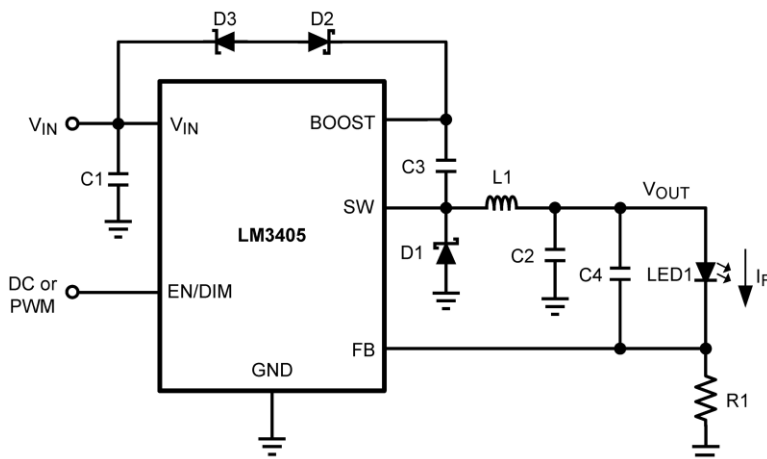

Copyright © 2016, Texas Instruments Incorporated

**Figure 13.  $V_{\text{BOOST}}$  Derived from  $V_{\text{IN}}$  Through a Series Zener**

**Feature Description (continued)**

An alternate method is to place the Zener diode D3 in a shunt configuration as shown in Figure 14. A small, 350-mW to 500-mW, 5.1-V Zener in a SOT or SOD package can be used for this purpose. A small ceramic capacitor such as a 6.3-V, 0.1-μF capacitor (C5) must be placed in parallel with the Zener diode. When the internal NMOS switch turns on, a pulse of current is drawn to charge the internal NMOS gate capacitance. The 0.1-μF parallel shunt capacitor ensures that the V<sub>BOOST</sub> voltage is maintained during this time. Resistor R2 must be chosen to provide enough RMS current to the Zener diode and to the BOOST pin. TI's recommended choice for the Zener current (I<sub>ZENER</sub>) is 1 mA. The current I<sub>BOOST</sub> into the BOOST pin supplies the gate current of the NMOS power switch. It reaches a maximum of around 3.6 mA at the highest gate drive voltage of 5.5 V over the LM3405 operating range.

For the worst case I<sub>BOOST</sub>, increase the current by 50%. In that case, the maximum boost current is Equation 6.

$$I_{\text{BOOST-MAX}} = 1.5 \times 3.6 \text{ mA} = 5.4 \text{ mA} \tag{6}$$

R2 is calculated with Equation 7.

$$R2 = (V_{\text{IN}} - V_{\text{ZENER}}) / (I_{\text{BOOST\_MAX}} + I_{\text{ZENER}}) \tag{7}$$

For example, let V<sub>IN</sub> = 12 V, V<sub>ZENER</sub> = 5V, I<sub>ZENER</sub> = 1 mA, then calculate Equation 8.

$$R2 = (12 \text{ V} - 5 \text{ V}) / (5.4 \text{ mA} + 1 \text{ mA}) = 1.09 \text{ k}\Omega \tag{8}$$

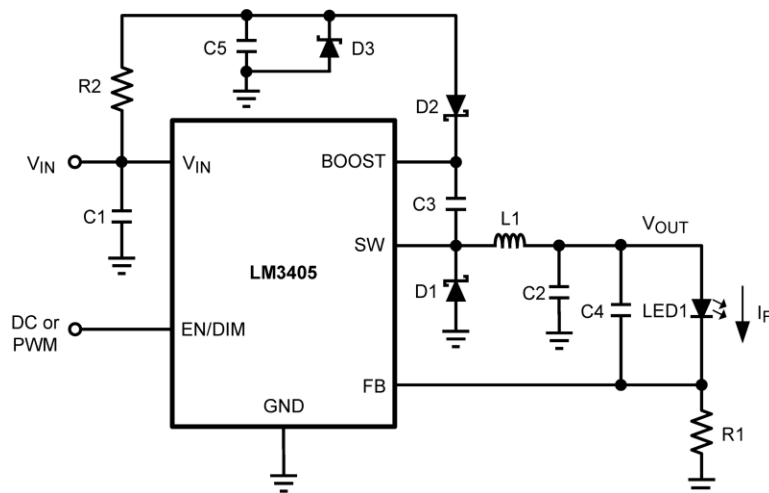

Copyright © 2016, Texas Instruments Incorporated

**Figure 14. V<sub>BOOST</sub> Derived from V<sub>IN</sub> Through a Shunt Zener**

The fourth method can be used in an application which has an external low voltage rail, V<sub>EXT</sub>. C3 can be charged through D2 from V<sub>EXT</sub>, independent of V<sub>IN</sub> and V<sub>OUT</sub> voltage levels. Again for best performance, ensure that the gate drive voltage, V<sub>EXT</sub> - V<sub>D2</sub> + V<sub>D1</sub>, falls in the range of 2.5 V to 5.5 V.

**7.3.2 Setting the LED Current**

LM3405 is a constant current buck regulator. The LEDs are connected between V<sub>OUT</sub> and the FB pin as shown in the Typical Applications. The FB pin is at 0.205 V in regulation and therefore the LED current I<sub>F</sub> is set by V<sub>FB</sub> and resistor R1 from FB to ground by Equation 9.

$$I_F = V_{\text{FB}} / R1 \tag{9}$$

I<sub>F</sub> must not exceed the 1-A current capability of LM3405 and, therefore, R1 minimum must be approximately 0.2 Ω. I<sub>F</sub> must also be kept above 200 mA for stable operation, and therefore R1 maximum must be approximately 1 Ω. If average LED currents less than 200 mA are desired, the EN/DIM pin can be used for PWM dimming. See LED PWM Dimming.

## Feature Description (continued)

### 7.3.3 Output Voltage

The output voltage is primarily determined by the number of LEDs (n) connected from  $V_{OUT}$  to FB pin and therefore  $V_{OUT}$  can be calculated with Equation 10.

$$V_{OUT} = ((n \times V_F) + V_{FB})$$

where

- $V_F$  is the forward voltage of one LED at the set LED current level (see LED manufacturer data sheet for forward characteristics curve) (10)

### 7.3.4 Enable Mode or Shutdown Mode

The LM3405 has both enable and shutdown modes that are controlled by the EN/DIM pin. Connecting a voltage source greater than 1.8 V to the EN/DIM pin enables the operation of LM3405, while reducing this voltage below 0.4 V places the part in a low quiescent current (0.3  $\mu$ A typical) shutdown mode. There is no internal pullup on EN/DIM pin, therefore an external signal is required to initiate switching. Do not allow this pin to float or rise to 0.3 V above  $V_{IN}$ . It must be noted that when the EN/DIM pin voltage rises above 1.8 V while the input voltage is greater than UVLO, there is a finite delay before switching starts. During this delay, the LM3405 goes through a power on reset state after which the internal soft-start process commences. The soft-start process limits the inrush current and brings up the LED current ( $I_F$ ) in a smooth and controlled fashion. The total combined duration of the power on reset delay, soft-start delay and the delay to fully establish the LED current is in the order of 100  $\mu$ s (see Figure 19).

The simplest way to enable the operation of LM3405 is to connect the EN/DIM pin to  $V_{IN}$  which allows self start-up of LM3405 whenever the input voltage is applied. However, when an input voltage of slow rise time is used to power the application and if both the input voltage and the output voltage are not fully established before the soft-start time elapses, the control circuit commands maximum duty cycle operation of the internal power switch to bring up the output voltage rapidly. When the feedback pin voltage exceeds 0.205 V, the duty cycle has to reduce from the maximum value accordingly, to maintain regulation. It takes a finite amount of time for this reduction of duty cycle and this results in a spike in LED current for a short duration as shown in Figure 15. In applications where this LED current overshoot is undesirable, EN/DIM pin voltage can be separately applied and delayed such that  $V_{IN}$  is fully established before the EN/DIM pin voltage reaches the enable threshold. The effect of delaying EN/DIM with respect to  $V_{IN}$  on the LED current is shown in Figure 16. For a fast rising input voltage (200  $\mu$ s for example), there is no need to delay the EN/DIM signal, because soft-start can smoothly bring up the LED current as shown in Figure 17.

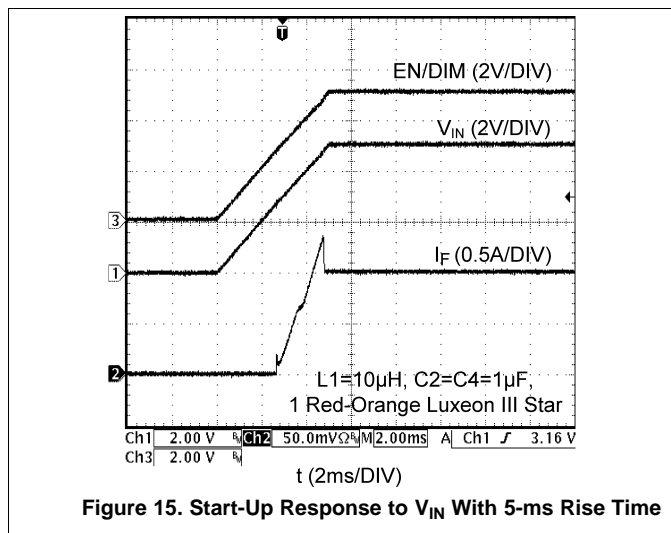

Figure 15. Start-Up Response to  $V_{IN}$  With 5-ms Rise Time

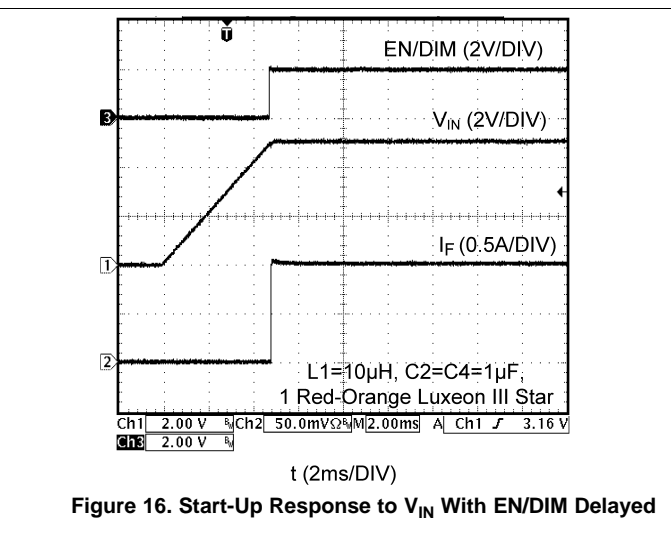
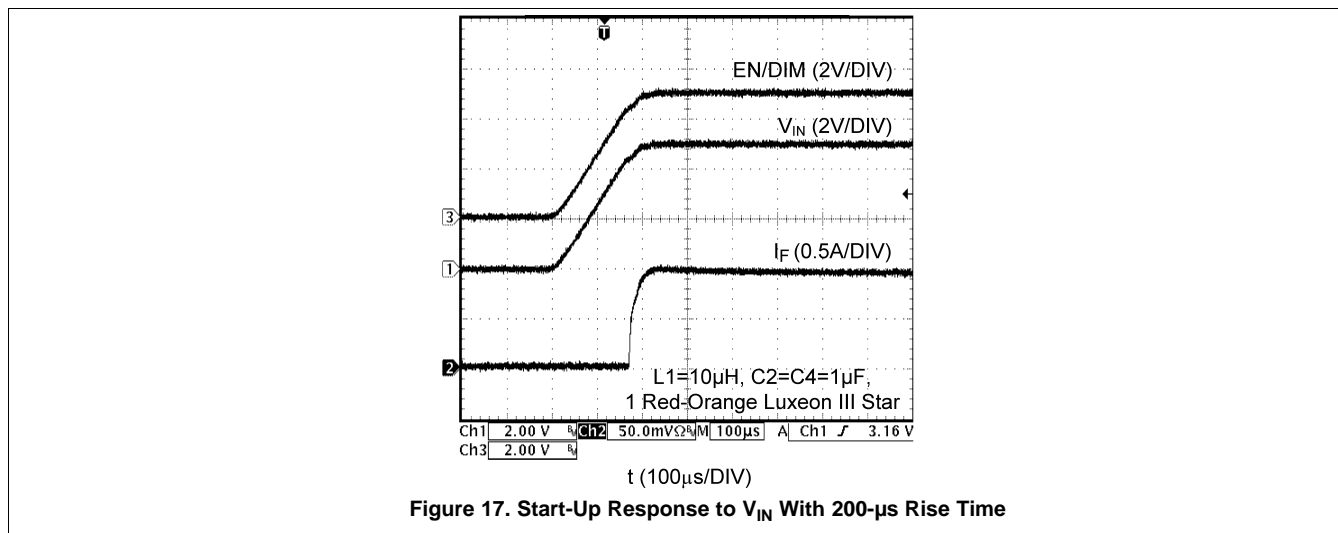

Figure 16. Start-Up Response to  $V_{IN}$  With EN/DIM Delayed

Feature Description (continued)



7.3.5 LED PWM Dimming

The LED brightness can be controlled by applying a periodic pulse signal to the EN/DIM pin and varying its frequency and/or duty cycle. This so-called PWM dimming method controls the average light output by pulsing the LED current between the set value and zero. A logic high level at the EN/DIM pin turns on the LED current whereas a logic low level turns off the LED current. Figure 18 shows a typical LED current waveform in PWM dimming mode. As explained in the previous section, there is approximately a 100-µs delay from the EN/DIM signal going high to fully establishing the LED current as shown in Figure 19. This 100-µs delay sets a maximum frequency limit for the driving signal that can be applied to the EN/DIM pin for PWM dimming. Figure 20 shows the average LED current versus duty cycle of PWM dimming signal for various frequencies. The applicable frequency range to drive LM3405 for PWM dimming is from 100 Hz to 5 kHz. The dimming ratio reduces drastically when the applied PWM dimming frequency is greater than 5 kHz.

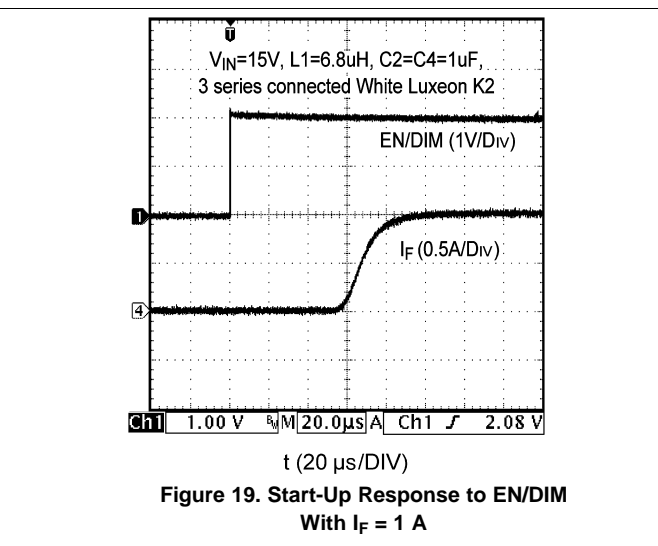
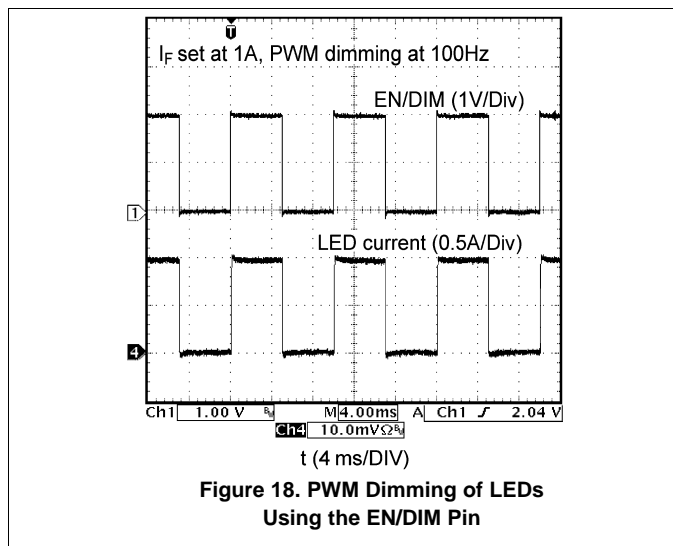

## Feature Description (continued)

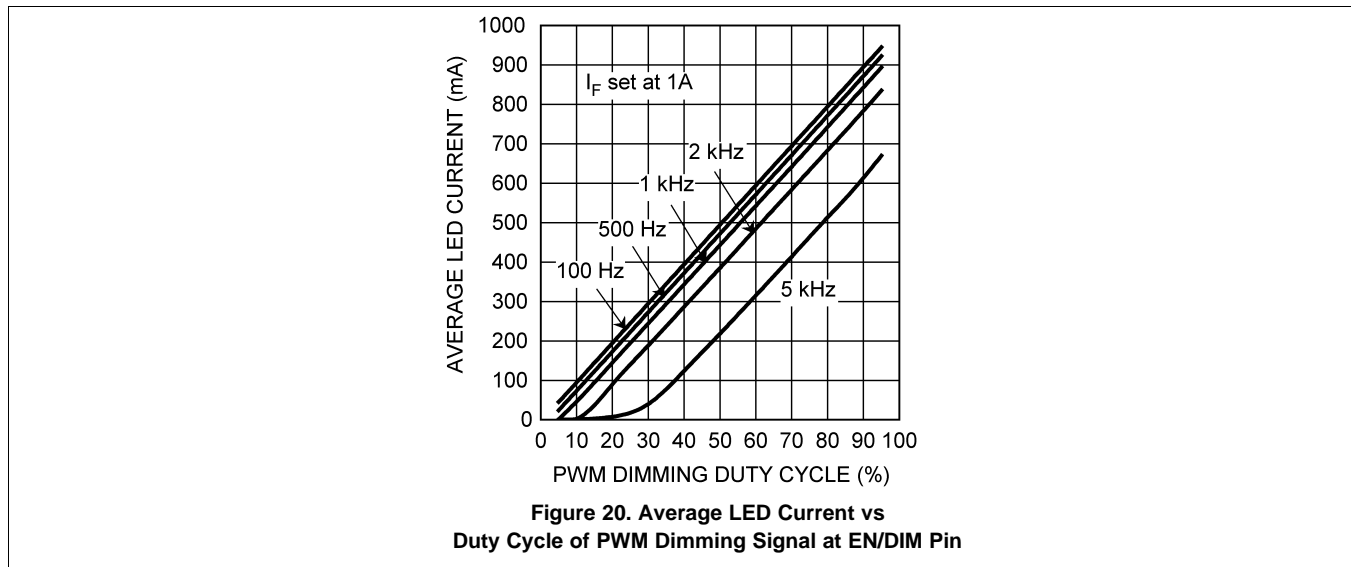

### 7.3.6 Undervoltage Lockout

Undervoltage lockout (UVLO) prevents the LM3405 from operating until the input voltage exceeds 2.74 V (typical). The UVLO threshold has approximately 440 mV of hysteresis, so the part operates until  $V_{IN}$  drops below 2.3 V (typical). Hysteresis prevents the part from turning off during power up if  $V_{IN}$  is non-monotonic.

### 7.3.7 Current Limit

The LM3405 uses cycle-by-cycle current limit to protect the internal power switch. During each switching cycle, a current limit comparator detects if the power switch current exceeds 2 A (typical), and turns off the switch until the next switching cycle begins.

### 7.3.8 Overcurrent Protection

The LM3405 has a built-in overcurrent comparator that compares the FB pin voltage to a threshold voltage that is 60% higher than the internal reference  $V_{REF}$ . Once the FB pin voltage exceeds this threshold level (typically 328 mV), the internal NMOS power switch is turned off, which allows the feedback voltage to decrease towards regulation. This threshold provides an upper limit for the LED current. LED current overshoot is limited to  $328 \text{ mV}/R1$  by this comparator during transients.

## 7.4 Device Functional Modes

### 7.4.1 Thermal Shutdown

Thermal shutdown limits total power dissipation by turning off the internal power switch when the IC junction temperature exceeds 165°C. After thermal shutdown occurs, the power switch does not turn on until the junction temperature drops below approximately 150°C.

## 8 Application and Implementation

### NOTE

Information in the following applications sections is not part of the TI component specification, and TI does not warrant its accuracy or completeness. TI's customers are responsible for determining suitability of components for their purposes. Customers should validate and test their design implementation to confirm system functionality.

### 8.1 Application Information

#### 8.1.1 Inductor (L1)

The duty cycle (D) can be approximated quickly using the ratio of output voltage ( $V_{OUT}$ ) to input voltage ( $V_{IN}$ ) in [Equation 11](#).

$$D = \frac{V_{OUT}}{V_{IN}} \quad (11)$$

The catch diode (D1) forward voltage drop and the voltage drop across the internal NMOS must be included to calculate a more accurate duty cycle. Calculate D by using [Equation 12](#).

$$D = \frac{V_{OUT} + V_{D1}}{V_{IN} + V_{D1} - V_{SW}} \quad (12)$$

$V_{SW}$  can be approximated by [Equation 13](#).

$$V_{SW} = I_F \times R_{DS(ON)} \quad (13)$$

The diode forward drop ( $V_{D1}$ ) can range from 0.3 V to 0.7 V depending on the quality of the diode. The lower  $V_{D1}$  is, the higher the operating efficiency of the converter.

The inductor value determines the output ripple current ( $\Delta i_L$ , as defined in [Figure 11](#)). Lower inductor values decrease the size of the inductor, but increases the output ripple current. An increase in the inductor value decreases the output ripple current. The ratio of ripple current to LED current is optimized when it is set between 0.3 and 0.4 at 1A LED current. This ratio  $r$  is defined as:

$$r = \frac{\Delta i_L}{I_F} \quad (14)$$

One must also ensure that the minimum current limit (1.2 A) is not exceeded, so the peak current in the inductor must be calculated. The peak current ( $I_{LPK}$ ) in the inductor is calculated with [Equation 15](#).

$$I_{LPK} = I_F + \Delta i_L / 2 \quad (15)$$

When the designed maximum output current is reduced, the ratio ( $r$ ) can be increased. At a current of 0.2 A,  $r$  can be made as high as 0.7. The ripple ratio can be increased at lighter loads because the net ripple is actually quite low, and if  $r$  remains constant the inductor value can be made quite large. An equation empirically developed for the maximum ripple ratio at any current below 2 A is calculated with [Equation 16](#) (note that this is just a guideline).

$$r = 0.387 \times I_{OUT}^{-0.3667} \quad (16)$$

The LM3405 operates at a high frequency allowing the use of ceramic output capacitors without compromising transient response. Ceramic capacitors allow higher inductor ripple without significantly increasing LED current ripple. See the output capacitor and feed-forward capacitor sections for more details on LED current ripple.

Now that the ripple current or ripple ratio is determined, the inductance is calculated by [Equation 17](#).

$$L = \frac{V_{OUT} + V_{D1}}{I_F \times r \times f_{SW}} \times (1-D)$$

where

- $f_{SW}$  is the switching frequency
- $I_F$  is the LED current

(17)

## Application Information (continued)

When selecting an inductor, make sure that it is capable of supporting the peak output current without saturating. Inductor saturation results in a sudden reduction in inductance and prevent the regulator from operating correctly. Because of the operating frequency of the LM3405, ferrite based inductors are preferred to minimize core losses. This presents little restriction, because the variety of ferrite based inductors is huge. Lastly, inductors with lower series resistance (DCR) provides better operating efficiency. For recommended inductor selection, see *Circuit Examples* and *Recommended Inductance Range* in [Table 1](#).

**Table 1. Recommended Inductance Range**

$I_F$	INDUCTANCE RANGE AND INDUCTOR CURRENT RIPPLE			
1 A	<b>4.7 <math>\mu</math>H TO 10 <math>\mu</math>H</b>			
	Inductance	4.7 $\mu$ H	6.8 $\mu$ H	10 $\mu$ H
	$\Delta i_L / I_F^{(1)}$	51%	35%	24%
0.6 A	<b>6.8 <math>\mu</math>H TO 15 <math>\mu</math>H</b>			
	Inductance	6.8 $\mu$ H	10 $\mu$ H	15 $\mu$ H
	$\Delta i_L / I_F^{(1)}$	58%	40%	26%
0.2 A	<b>4.7 <math>\mu</math>H<sup>(2)</sup> TO 22 <math>\mu</math>H</b>			
	Inductance	10 $\mu$ H	15 $\mu$ H	22 $\mu$ H
	$\Delta i_L / I_F^{(1)}$	119%	79%	54%

(1) Maximum over full range of  $V_{IN}$  and  $V_{OUT}$ .

(2) Small inductance improves stability without causing a significant increase in LED current ripple.

### 8.1.2 Input Capacitor (C1)

An input capacitor is necessary to ensure that  $V_{IN}$  does not drop excessively during switching transients. The primary specifications of the input capacitor are capacitance, voltage rating, RMS current rating, and ESL (Equivalent Series Inductance). The input voltage rating is specifically stated by the capacitor manufacturer. Check any recommended deratings and also verify if there is any significant change in capacitance at the operating input voltage and the operating temperature. The input capacitor maximum RMS input current rating ( $I_{RMS-IN}$ ) must be greater than [Equation 18](#).

$$I_{RMS-IN} = I_F \times \sqrt{D \times \left(1 - D + \frac{r^2}{12}\right)} \quad (18)$$

[Equation 18](#) shows that maximum RMS capacitor current occurs when  $D = 0.5$ . Always calculate the RMS at the point where the duty cycle  $D$ , is closest to 0.5. The ESL of an input capacitor is usually determined by the effective cross sectional area of the current path. A large-leaded capacitor has high ESL and an 0805 ceramic chip capacitor has very low ESL. At the operating frequency of the LM3405, certain capacitors may have an ESL so large that the resulting inductive impedance ( $2\pi fL$ ) is higher than that required to provide stable operation. TI strongly recommends using ceramic capacitors due to their low ESR and low ESL. A 10- $\mu$ F multilayer ceramic capacitor (MLCC) is a good choice for most applications. In cases where large capacitance is required, use surface mount capacitors such as Tantalum capacitors and place at least a 1- $\mu$ F ceramic capacitor close to the  $V_{IN}$  pin. For MLCCs, TI recommends using X7R or X5R dielectrics. Consult capacitor manufacturer datasheet to see how rated capacitance varies over operating conditions.

### 8.1.3 Output Capacitor (C2)

The output capacitor is selected based upon the desired reduction in LED current ripple. A 1- $\mu$ F ceramic capacitor results in very low LED current ripple for most applications. Due to the high switching frequency, the 1- $\mu$ F capacitor alone (without feed-forward capacitor C4) can filter more than 90% of the inductor current ripple for most applications where the sum of LED dynamic resistance and R1 is larger than 1  $\Omega$ . Because the internal compensation is tailored for small output capacitance with very low ESR, TI strongly recommends using a ceramic capacitor with capacitance less than 3.3  $\mu$ F.

Given the availability and quality of MLCCs and the expected output voltage of designs using the LM3405, there is really no need to review other capacitor technologies. A benefit of ceramic capacitors is their ability to bypass high frequency noise. A certain amount of switching edge noise couples through the parasitic capacitances in the inductor to the output. A ceramic capacitor bypasses this noise. In cases where large capacitance is required, use Electrolytic or Tantalum capacitors with large ESR, and verify the loop performance on the bench. Like the input capacitor, multilayer ceramic capacitors are recommended X7R or X5R. Again, verify actual capacitance at the desired operating voltage and temperature.

Check the RMS current rating of the capacitor. The maximum RMS current rating of the capacitor is calculated with Equation 19.

$$I_{RMS-OUT} = I_F \times \frac{r}{\sqrt{12}} \tag{19}$$

One may select a 1206 size ceramic capacitor for C2, because its current rating is typically higher than 1 A, more than enough for the requirement.

### 8.1.4 Feed-Forward Capacitor (C4)

The feed-forward capacitor (designated as C4) connected in parallel with the LED string is required to provide multiple benefits to the LED driver design. It greatly improves the large signal transient response and suppresses LED current overshoot that may otherwise occur during PWM dimming; it also helps to shape the rise and fall times of the LED current pulse during PWM dimming thus reducing EMI emission; it reduces LED current ripple by bypassing some of inductor ripple from flowing through the LED. For most applications, a 1-μF ceramic capacitor is sufficient. In fact, the combination of a 1-μF feed-forward ceramic capacitor and a 1-μF output ceramic capacitor leads to less than 1% current ripple flowing through the LED. Lower and higher C4 values can be used, but bench validation is required to ensure the performance meets the application requirement.

Figure 21 shows a typical LED current waveform during PWM dimming without feed-forward capacitor. At the beginning of each PWM cycle, overshoot can be seen in the LED current. Adding a 1-μF feed-forward capacitor can totally remove the overshoot as shown in Figure 22.

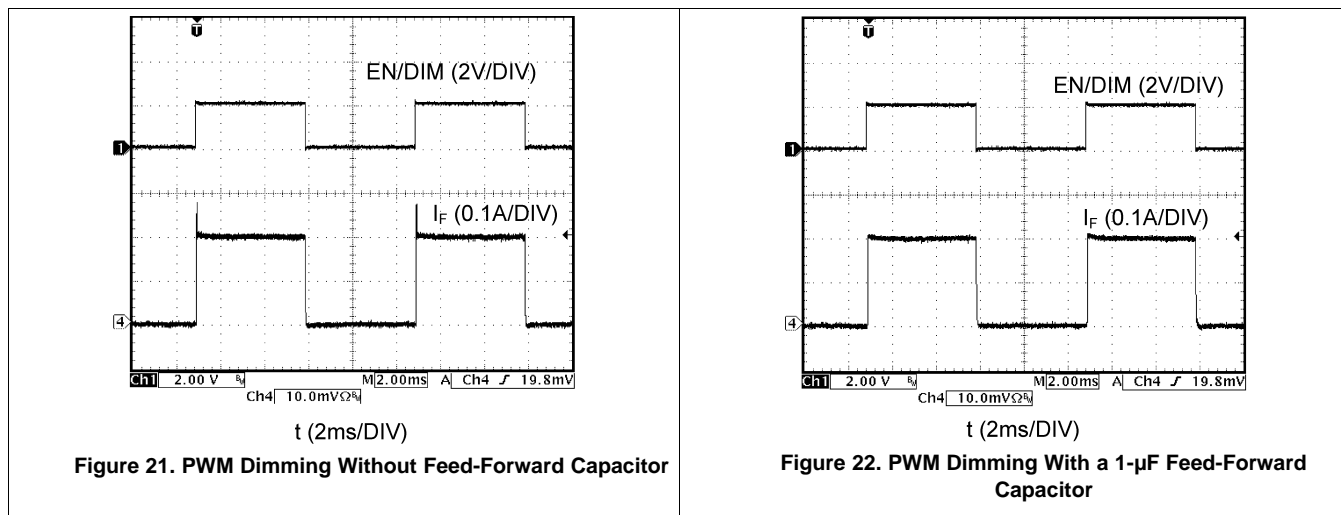

Figure 21. PWM Dimming Without Feed-Forward Capacitor

Figure 22. PWM Dimming With a 1-μF Feed-Forward Capacitor

### 8.1.5 Catch Diode (D1)

The catch diode (D1) conducts during the switch off-time. A Schottky diode is required for its fast switching time and low forward voltage drop. The catch diode must be chosen such that its current rating is greater than Equation 20.

$$I_{D1} = I_F \times (1-D) \tag{20}$$

The reverse breakdown rating of the diode must be at least the maximum input voltage plus appropriate margin. To improve efficiency, choose a Schottky diode with a low forward voltage drop.

### 8.1.6 Boost Diode (D2)

TI recommends a standard diode such as the 1N4148 type. For  $V_{\text{BOOST}}$  circuits derived from voltages less than 3.3 V, a small-signal Schottky diode is recommended for better efficiency. A good choice is the BAT54 small signal diode.

### 8.1.7 Boost Capacitor (C3)

A 0.01- $\mu\text{F}$  ceramic capacitor with a voltage rating of at least 6.3 V is sufficient. The X7R and X5R MLCCs provide the best performance.

### 8.1.8 Power Loss Estimation

The main power loss in LM3405 includes three basic types of loss in the internal power switch: conduction loss, switching loss, and gate charge loss. In addition, there is loss associated with the power required for the internal circuitry of IC.

The conduction loss is calculated with [Equation 21](#).

$$P_{\text{COND}} = \left( I_F^2 \times D \right) \times \left( 1 + \frac{1}{3} \times \left( \frac{\Delta i_L}{I_F} \right)^2 \right) \times R_{\text{DS(ON)}} \quad (21)$$

If the inductor ripple current is fairly small (for example, less than 40%), the conduction loss can be simplified with [Equation 22](#).

$$P_{\text{COND}} = I_F^2 \times R_{\text{DS(ON)}} \times D \quad (22)$$

The switching loss occurs during the switch on and off transition periods, where voltage and current overlap resulting in power loss. The simplest means to determine this loss is to empirically measure the rise and fall times (10% to 90%) of the voltage at the switch pin.

Switching power loss is calculated with [Equation 23](#).

$$P_{\text{SW}} = 0.5 \times V_{\text{IN}} \times I_F \times f_{\text{SW}} \times (T_{\text{RISE}} + T_{\text{FALL}}) \quad (23)$$

The gate charge loss is associated with the gate charge  $Q_G$  required to drive the switch with [Equation 24](#).

$$P_G = f_{\text{SW}} \times V_{\text{IN}} \times Q_G \quad (24)$$

The power loss required for operation of the internal circuitry is calculated with [Equation 25](#).

$$P_Q = I_Q \times V_{\text{IN}} \quad (25)$$

$I_Q$  is the quiescent operating current, and is typically around 1.8mA for the LM3405.

The total power loss in the IC is [Equation 26](#).

$$P_{\text{INTERNAL}} = P_{\text{COND}} + P_{\text{SW}} + P_G + P_Q \quad (26)$$

An example of power losses for a typical application is shown in [Table 2](#), [Equation 27](#), and [Equation 28](#) ( $D$  is calculated to be 0.36).

**Table 2. Power Loss Tabulation**

CONDITIONS		POWER LOSS	
$V_{\text{IN}}$	12 V	—	—
$V_{\text{OUT}}$	3.9 V	—	—
$I_{\text{OUT}}$	1 A	—	—
$V_{\text{D1}}$	0.45 V	—	—
$R_{\text{DS(ON)}}$	300 m $\Omega$	$P_{\text{COND}}$	111 mW
$f_{\text{SW}}$	1.6 MHz	—	—
$T_{\text{RISE}}$	18 ns	$P_{\text{SW}}$	288 mW
$T_{\text{FALL}}$	12 ns		
$I_Q$	1.8 mA	$P_Q$	22 mW
$Q_G$	1.4 nC	$P_G$	27 mW

$$\Sigma ( P_{COND} + P_{SW} + P_Q + P_G ) = P_{INTERNAL} \quad (27)$$

$$P_{INTERNAL} = 448 \text{ mW} \quad (28)$$

## 8.2 Typical Applications

### 8.2.1 $V_{BOOST}$ Derived from $V_{IN}$ ( $V_{IN} = 5 \text{ V}$ , $I_F = 1 \text{ A}$ )

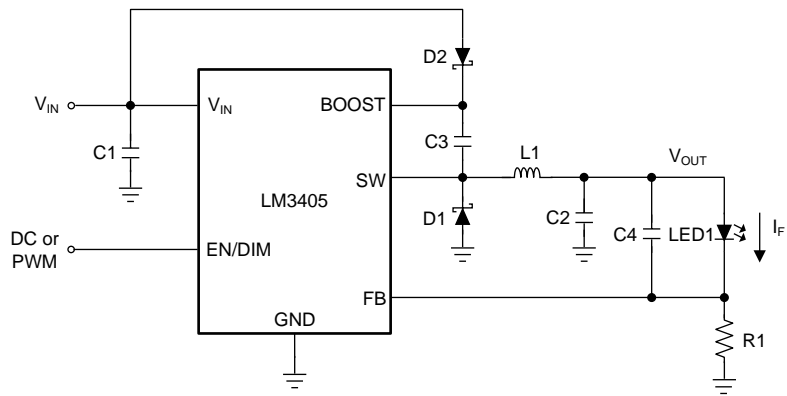

Copyright © 2016, Texas Instruments Incorporated

**Figure 23.  $V_{BOOST}$  Derived from  $V_{IN}$  ( $V_{IN} = 5 \text{ V}$ ,  $I_F = 1 \text{ A}$ ) Diagram**

#### 8.2.1.1 Design Requirements

The following are the parameter specifications for this design example:

- Input voltage,  $V_{IN} = 5 \text{ V} \pm 10\%$
- LED current,  $I_F = 1 \text{ A}$
- LED forward voltage,  $V_{LED} = 3.4 \text{ V}$
- Output voltage,  $V_{OUT} = 3.4 \text{ V} + 0.2 \text{ V} = 3.6 \text{ V}$
- Ripple ratio =  $r < 0.6$
- PWM dimmable

#### 8.2.1.2 Detailed Design Procedure

##### 8.2.1.2.1 Calculate Duty Cycle (D)

Calculate the nominal duty cycle for calculations and ensure the maximum duty cycle is not exceeded in the application using [Equation 29](#).

$$D = \frac{V_{OUT}}{V_{IN}} = \frac{3.6\text{V}}{5\text{V}} = 0.72 \quad (29)$$

Using the same equation  $D_{MAX}$  can be calculated for the minimum input voltage of 4.5 V. The duty cycle at 4.5 V is 0.8 which is less than the minimum  $D_{MAX}$  of 0.85 specified in [Electrical Characteristics](#).

##### 8.2.1.2.2 Choose Capacitor Values (C1, C2, C3, and C4)

Low input voltage applications and PWM dimming applications generally require more input capacitance so the higher value of  $C1 = 10 \mu\text{F}$  is chosen for best performance. The other capacitor values chosen are the recommended values of  $C2 = C4 = 1 \mu\text{F}$  and  $C3 = 0.01 \mu\text{F}$ . All capacitors chosen are X5R or X7R dielectric ceramic capacitors of sufficient voltage rating.

## Typical Applications (continued)

### 8.2.1.2.3 Set the Nominal LED Current (R1)

The nominal LED current at 100% PWM dimming duty cycle is set by the resistor R1. R1 can be calculated using Equation 30.

$$R1 = \frac{V_{FB}}{I_F} = \frac{0.205V}{1A} = 0.205\Omega \quad (30)$$

The standard value of R1 = 0.2 Ω is chosen. R1 must have a power rating of at least 1/4 W.

### 8.2.1.2.4 Choose Diodes (D1 and D2)

For the boost diode, D2, choose a low current diode with a voltage rating greater than the input voltage to give some margin. D2 must also be a schottky to minimize the forward voltage drop. For this example a schottky diode of D2 = 100 mA, 30 V is chosen. The catch diode, D1, must be a schottky diode and must have a voltage rating greater than the input voltage and a current rating greater than the average current. The average current in D1 can be calculated with Equation 31.

$$I_{D1} = I_F \times (1 - D) = 1A \times (1 - 0.72) = 0.28A \quad (31)$$

For this example D1 = 1 A, 10 V is chosen.

### 8.2.1.2.5 Calculate the Inductor Value (L1)

The inductor value is chosen for a given ripple ratio (r). To calculate L1 the forward voltage of D1 is required. In this case the chosen diode has a forward voltage drop of  $V_F = 0.37$  V. Given the desired ripple ratio L1 is calculated with Equation 32.

$$L = \frac{V_{OUT} + V_{D1}}{I_F \times r \times f_{SW}} = \frac{3.6V + 0.37V}{1A \times 0.6 \times 1.6MHz} = 4.14\mu H \quad (32)$$

The next larger standard value of L1 = 4.7 μH is chosen. A ripple ratio of 0.6 translates to a  $\Delta i_L$  of 600 mA and a peak inductor current of 1.3 A ( $I_F + \Delta i_L/2$ ). Choose an inductor with a saturation current rating of greater than 1.3 A.

**Table 3. Bill of Materials for Figure 23**

PART ID	PART VALUE	PART NUMBER	MANUFACTURER
U1	1-A LED Driver	LM3405	Texas Instruments
C1, Input capacitor	10 μF, 6.3 V, X5R	C3216X5R0J106M	TDK
C2, Output capacitor	1 μF, 10 V, X7R	GRM319R71A105KC01D	Murata
C3, Boost capacitor	0.01 μF, 16 V, X7R	0805YC103KAT2A	AVX
C4, Feedforward capacitor	1 μF, 10 V, X7R	GRM319R71A105KC01D	Murata
D1, Catch diode	Schottky, 0.37 V at 1A, $V_R = 10$ V	MBRM110LT1G	ON Semiconductor
D2, Boost diode	Schottky, 0.36 V at 15 mA	CMDSH-3	Central Semiconductor
L1	4.7 μH, 1.6 A	SLF6028T-4R7M1R6	TDK
R1	0.2 Ω, 0.5 W, 1%	WSL2010R2000FEA	Vishay

### 8.2.1.3 Application Curve

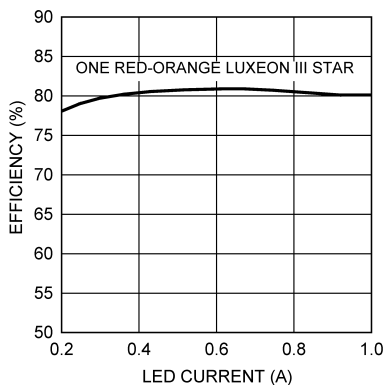
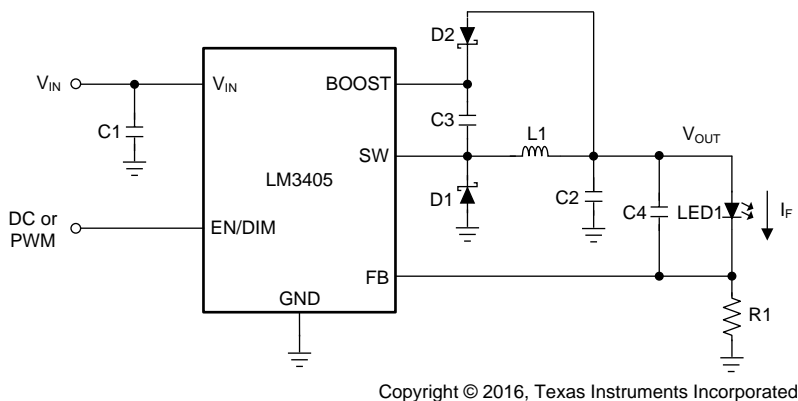

Figure 24. Efficiency vs Input Voltage

## 8.3 System Examples

### 8.3.1 $V_{BOOST}$ Derived From $V_{OUT}$ ( $V_{IN} = 12\text{ V}$ , $I_F = 1\text{ A}$ )



Copyright © 2016, Texas Instruments Incorporated

Figure 25.  $V_{BOOST}$  Derived From  $V_{OUT}$  ( $V_{IN} = 12\text{ V}$ ,  $I_F = 1\text{ A}$ ) Diagram

#### 8.3.1.1 Bill of Materials

Table 4. Bill of Materials for Figure 25

PART ID	PART VALUE	PART NUMBER	MANUFACTURER
U1	1-A LED Driver	LM3405	Texas Instruments
C1, Input capacitor	10 $\mu\text{F}$ , 25 V, X5R	ECJ-3YB1E106K	Panasonic
C2, Output capacitor	1 $\mu\text{F}$ , 10 V, X7R	GRM319R71A105KC01D	Murata
C3, Boost capacitor	0.01 $\mu\text{F}$ , 16 V, X7R	0805YC103KAT2A	AVX
C4, Feedforward capacitor	1 $\mu\text{F}$ , 10 V, X7R	GRM319R71A105KC01D	Murata
D1, Catch diode	Schottky, 0.5 V at 1 A, $V_R = 30\text{ V}$	SS13	Vishay
D2, Boost diode	Schottky, 0.36 V at 15 mA	CMDSH-3	Central Semiconductor
L1	4.7 $\mu\text{H}$ , 1.6 A	SLF6028T-4R7M1R6	TDK
R1	0.2 $\Omega$ , 0.5 W, 1%	WSL2010R2000FEA	Vishay

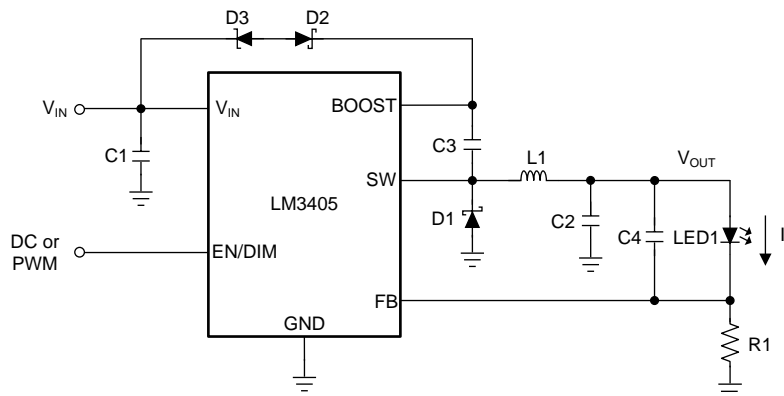
**8.3.2  $V_{\text{BOOST}}$  Derived From  $V_{\text{IN}}$  Through a Series Zener Diode, D3 ( $V_{\text{IN}} = 15 \text{ V}$ ,  $I_{\text{F}} = 1 \text{ A}$ )**

Copyright © 2016, Texas Instruments Incorporated

**Figure 26.  $V_{\text{BOOST}}$  Derived From  $V_{\text{IN}}$  Through a Series Zener Diode, D3 ( $V_{\text{IN}} = 15 \text{ V}$ ,  $I_{\text{F}} = 1 \text{ A}$ ) Diagram**
**8.3.2.1 Bill of Materials**
**Table 5. Bill of Materials for Figure 26**

PART ID	PART VALUE	PART NUMBER	MANUFACTURER
U1	1-A LED Driver	LM3405	Texas Instruments
C1, Input capacitor	10 $\mu\text{F}$ , 25 V, X5R	ECJ-3YB1E106K	Panasonic
C2, Output capacitor	1 $\mu\text{F}$ , 10 V, X7R	GRM319R71A105KC01D	Murata
C3, Boost capacitor	0.01 $\mu\text{F}$ , 16 V, X7R	0805YC103KAT2A	AVX
C4, Feedforward capacitor	1 $\mu\text{F}$ , 10 V, X7R	GRM319R71A105KC01D	Murata
D1, Catch diode	Schottky, 0.5 V at 1A, $V_{\text{R}} = 30 \text{ V}$	SS13	Vishay
D2, Boost diode	Schottky, 0.36 V at 15 mA	CMDSH-3	Central Semiconductor
D3, Zener diode	11 V, 350 mW, SOT-23	BZX84C11	Fairchild
L1	6.8 $\mu\text{H}$ , 1.5 A	SLF6028T-6R8M1R5	TDK
R1	0.2 $\Omega$ , 0.5 W, 1%	WSL2010R2000FEA	Vishay

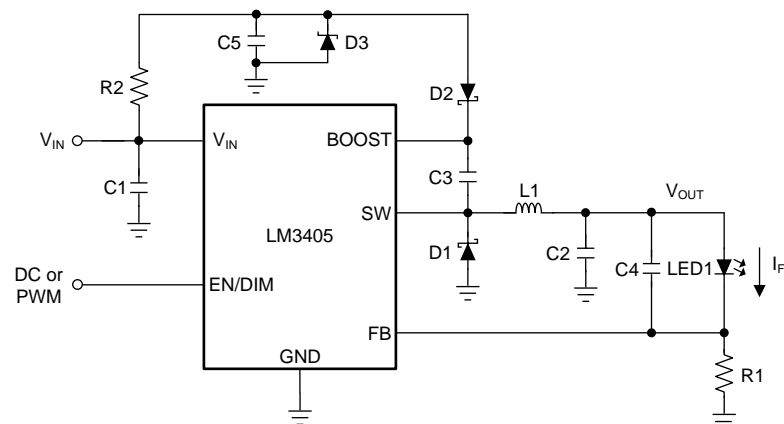
**8.3.3  $V_{\text{BOOST}}$  Derived From  $V_{\text{IN}}$  Through a Shunt Zener Diode, D3 ( $V_{\text{IN}} = 15 \text{ V}$ ,  $I_{\text{F}} = 1 \text{ A}$ )**

Copyright © 2016, Texas Instruments Incorporated

**Figure 27.  $V_{\text{BOOST}}$  Derived From  $V_{\text{IN}}$  Through a Shunt Zener Diode, D3 ( $V_{\text{IN}} = 15 \text{ V}$ ,  $I_{\text{F}} = 1 \text{ A}$ ) Diagram**

8.3.3.1 Bill of Materials

Table 6. Bill of Materials for Figure 27

PART ID	PART VALUE	PART NUMBER	MANUFACTURER
U1	1-A LED Driver	LM3405	Texas Instruments
C1, Input capacitor	10 $\mu$ F, 25 V, X5R	ECJ-3YB1E106K	Panasonic
C2, Output capacitor	1 $\mu$ F, 10 V, X7R	GRM319R71A105KC01D	Murata
C3, Boost capacitor	0.01 $\mu$ F, 16 V, X7R	0805YC103KAT2A	AVX
C4, Feedforward capacitor	1 $\mu$ F, 10 V, X7R	GRM319R71A105KC01D	Murata
C5, Shunt capacitor	0.1 $\mu$ F, 16 V, X7R	GRM219R71C104KA01D	Murata
D1, Catch diode	Schottky, 0.5 V at 1 A, $V_R = 30$ V	SS13	Vishay
D2, Boost diode	Schottky, 0.36 V at 15 mA	CMDSH-3	Central Semiconductor
D3, Zener diode	4.7 V, 350 mW, SOT-23	BZX84C4 V7	Fairchild
L1	6.8 $\mu$ H, 1.5 A	SLF6028T-6R8M1R5	TDK
R1	0.2 $\Omega$ , 0.5 W, 1%	WSL2010R2000FEA	Vishay
R2	1.91 k $\Omega$ , 1%	CRCW08051K91FKEA	Vishay

8.3.4  $V_{BOOST}$  Derived from  $V_{OUT}$  Through a Series Zener Diode, D3 ( $V_{IN} = 15$  V,  $I_F = 1$  A)

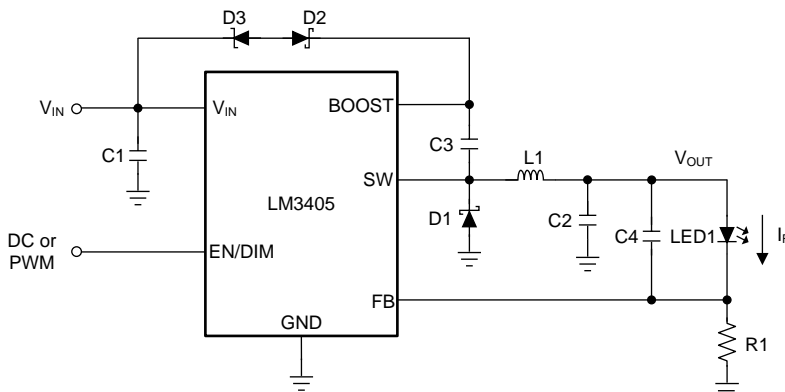

Copyright © 2016, Texas Instruments Incorporated

Figure 28.  $V_{BOOST}$  Derived from  $V_{OUT}$  Through a Series Zener Diode, D3 ( $V_{IN} = 15$  V,  $I_F = 1$  A) Diagram

8.3.4.1 Bill of Materials

Table 7. Bill of Materials for Figure 28

PART ID	PART VALUE	PART NUMBER	MANUFACTURER
U1	1-A LED Driver	LM3405	Texas Instruments
C1, Input capacitor	10 $\mu$ F, 25 V, X5R	ECJ-3YB1E106K	Panasonic
C2, Output capacitor	1 $\mu$ F, 16 V, X7R	GRM319R71A105KC01D	Murata
C3, Boost capacitor	0.01 $\mu$ F, 16 V, X7R	0805YC103KAT2A	AVX
C4, Feedforward capacitor	1 $\mu$ F, 16 V, X7R	GRM319R71A105KC01D	Murata
D1, Catch diode	Schottky, 0.5 V at 1 A, $V_R = 30$ V	SS13	Vishay
D2, Boost diode	Schottky, 0.36 V at 15 mA	CMDSH-3	Central Semiconductor
D3, Zener diode	11 V, 350 mW, SOT-23	BZX84C11	Fairchild
L1	6.8 $\mu$ H, 1.5 A	SLF6028T-6R8M1R5	TDK
R1	0.2 $\Omega$ , 0.5 W, 1%	WSL2010R2000FEA	Vishay

## 9 Power Supply Recommendations

Any DC output power supply may be used provided it has a high enough voltage and current rating required for the particular application.

## 10 Layout

### 10.1 Layout Guidelines

When planning the layout there are a few things to consider when trying to achieve a clean, regulated output. The most important consideration when completing the layout is the close coupling of the GND connections of the input capacitor C1 and the catch diode D1. These ground ends must be close to one another and be connected to the GND plane with at least two vias. Place these components as close to the IC as possible. The next consideration is the location of the GND connection of the output capacitor C2, which must be near the GND connections of C1 and D1.

There must be a continuous ground plane on the bottom layer of a two-layer board.

The FB pin is a high impedance node and take care to make the FB trace short to avoid noise pickup that causes inaccurate regulation. The LED current setting resistor R1 must be placed as close as possible to the IC, with the GND of R1 placed as close as possible to the GND of the IC. The  $V_{OUT}$  trace to LED anode must be routed away from the inductor and any other traces that are switching.

High AC currents flow through the  $V_{IN}$ , SW and  $V_{OUT}$  traces, so they must be as short and wide as possible. Radiated noise can be decreased by choosing a shielded inductor.

The remaining components must also be placed as close as possible to the IC. See [AN-1229 SIMPLE SWITCHER® PCB Layout Guidelines](#) (SNVA054) for further considerations.

### 10.2 Layout Example

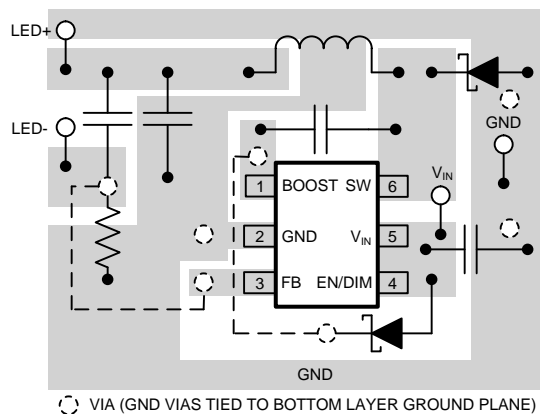

Schematic in [Figure 23](#)

**Figure 29. LM3405 Layout Example**

## 11 Device and Documentation Support

### 11.1 Documentation Support

#### 11.1.1 Related Documentation

For related documentation see the following:

- [AN-1229 SIMPLE SWITCHER® PCB Layout Guidelines](#) (SNVA054)
- [AN-1644 Powering and Dimming High-Brightness LEDs with the LM3405 Constant-Current Buck Regulator](#) (SNVA247)
- [AN-1656 Design Challenges of Switching LED Drivers](#) (SNVA253)
- [AN-1685 LM3405A Demo Board](#) (SNVA271)
- [AN-1899 LM3405A VSSOP Evaluation Board](#) (SNVA370)
- [AN-1982 Small, Wide Input Voltage Range LM2842 Keeps LEDs Cool](#) (SNVA402)
- [LM3405A Reference Design for MR16 LED Bulb, 600mA](#) (SNVU101)

#### 11.2 Receiving Notification of Documentation Updates

To receive notification of documentation updates, navigate to the device product folder on ti.com. In the upper right corner, click on *Alert me* to register and receive a weekly digest of any product information that has changed. For change details, review the revision history included in any revised document.

#### 11.3 Community Resource

The following links connect to TI community resources. Linked contents are provided "AS IS" by the respective contributors. They do not constitute TI specifications and do not necessarily reflect TI's views; see TI's [Terms of Use](#).

**TI E2E™ Online Community** *TI's Engineer-to-Engineer (E2E) Community*. Created to foster collaboration among engineers. At e2e.ti.com, you can ask questions, share knowledge, explore ideas and help solve problems with fellow engineers.

**Design Support** *TI's Design Support* Quickly find helpful E2E forums along with design support tools and contact information for technical support.

#### 11.4 Trademarks

E2E is a trademark of Texas Instruments.  
SIMPLE SWITCHER is a registered trademark of Texas Instruments.  
All other trademarks are the property of their respective owners.

#### 11.5 Electrostatic Discharge Caution



These devices have limited built-in ESD protection. The leads should be shorted together or the device placed in conductive foam during storage or handling to prevent electrostatic damage to the MOS gates.

#### 11.6 Glossary

[SLYZ022](#) — *TI Glossary*.

This glossary lists and explains terms, acronyms, and definitions.

## 12 Mechanical, Packaging, and Orderable Information

The following pages include mechanical, packaging, and orderable information. This information is the most current data available for the designated devices. This data is subject to change without notice and revision of this document. For browser-based versions of this data sheet, refer to the left-hand navigation.

**PACKAGING INFORMATION**

Orderable Device	Status (1)	Package Type	Package Drawing	Pins	Package Qty	Eco Plan (2)	Lead/Ball Finish (6)	MSL Peak Temp (3)	Op Temp (°C)	Device Marking (4/5)	Samples
LM3405XMK/NOPB	ACTIVE	SOT-23-THIN	DDC	6	1000	Green (RoHS & no Sb/Br)	CU SN	Level-1-260C-UNLIM	-40 to 125	SPNB	<a href="#">Samples</a>
LM3405XMKX/NOPB	ACTIVE	SOT-23-THIN	DDC	6	3000	Green (RoHS & no Sb/Br)	CU SN	Level-1-260C-UNLIM	-40 to 125	SPNB	<a href="#">Samples</a>

(1) The marketing status values are defined as follows:

**ACTIVE:** Product device recommended for new designs.

**LIFEBUY:** TI has announced that the device will be discontinued, and a lifetime-buy period is in effect.

**NRND:** Not recommended for new designs. Device is in production to support existing customers, but TI does not recommend using this part in a new design.

**PREVIEW:** Device has been announced but is not in production. Samples may or may not be available.

**OBSOLETE:** TI has discontinued the production of the device.

(2) Eco Plan - The planned eco-friendly classification: Pb-Free (RoHS), Pb-Free (RoHS Exempt), or Green (RoHS & no Sb/Br) - please check <http://www.ti.com/productcontent> for the latest availability information and additional product content details.

**TBD:** The Pb-Free/Green conversion plan has not been defined.

**Pb-Free (RoHS):** TI's terms "Lead-Free" or "Pb-Free" mean semiconductor products that are compatible with the current RoHS requirements for all 6 substances, including the requirement that lead not exceed 0.1% by weight in homogeneous materials. Where designed to be soldered at high temperatures, TI Pb-Free products are suitable for use in specified lead-free processes.

**Pb-Free (RoHS Exempt):** This component has a RoHS exemption for either 1) lead-based flip-chip solder bumps used between the die and package, or 2) lead-based die adhesive used between the die and leadframe. The component is otherwise considered Pb-Free (RoHS compatible) as defined above.

**Green (RoHS & no Sb/Br):** TI defines "Green" to mean Pb-Free (RoHS compatible), and free of Bromine (Br) and Antimony (Sb) based flame retardants (Br or Sb do not exceed 0.1% by weight in homogeneous material)

(3) MSL, Peak Temp. - The Moisture Sensitivity Level rating according to the JEDEC industry standard classifications, and peak solder temperature.

(4) There may be additional marking, which relates to the logo, the lot trace code information, or the environmental category on the device.

(5) Multiple Device Markings will be inside parentheses. Only one Device Marking contained in parentheses and separated by a "~" will appear on a device. If a line is indented then it is a continuation of the previous line and the two combined represent the entire Device Marking for that device.

(6) Lead/Ball Finish - Orderable Devices may have multiple material finish options. Finish options are separated by a vertical ruled line. Lead/Ball Finish values may wrap to two lines if the finish value exceeds the maximum column width.

**Important Information and Disclaimer:** The information provided on this page represents TI's knowledge and belief as of the date that it is provided. TI bases its knowledge and belief on information provided by third parties, and makes no representation or warranty as to the accuracy of such information. Efforts are underway to better integrate information from third parties. TI has taken and continues to take reasonable steps to provide representative and accurate information but may not have conducted destructive testing or chemical analysis on incoming materials and chemicals. TI and TI suppliers consider certain information to be proprietary, and thus CAS numbers and other limited information may not be available for release.

In no event shall TI's liability arising out of such information exceed the total purchase price of the TI part(s) at issue in this document sold by TI to Customer on an annual basis.

**TAPE AND REEL INFORMATION**

**QUADRANT ASSIGNMENTS FOR PIN 1 ORIENTATION IN TAPE**

\*All dimensions are nominal

Device	Package Type	Package Drawing	Pins	SPQ	Reel Diameter (mm)	Reel Width W1 (mm)	A0 (mm)	B0 (mm)	K0 (mm)	P1 (mm)	W (mm)	Pin1 Quadrant
LM3405XMK/NOPB	SOT-23-THIN	DDC	6	1000	178.0	8.4	3.2	3.2	1.4	4.0	8.0	Q3
LM3405XMKX/NOPB	SOT-23-THIN	DDC	6	3000	178.0	8.4	3.2	3.2	1.4	4.0	8.0	Q3

**TAPE AND REEL BOX DIMENSIONS**

\*All dimensions are nominal

Device	Package Type	Package Drawing	Pins	SPQ	Length (mm)	Width (mm)	Height (mm)
LM3405XMK/NOPB	SOT-23-THIN	DDC	6	1000	210.0	185.0	35.0
LM3405XMKX/NOPB	SOT-23-THIN	DDC	6	3000	210.0	185.0	35.0

DDC (R-PDSO-G6)

PLASTIC SMALL-OUTLINE

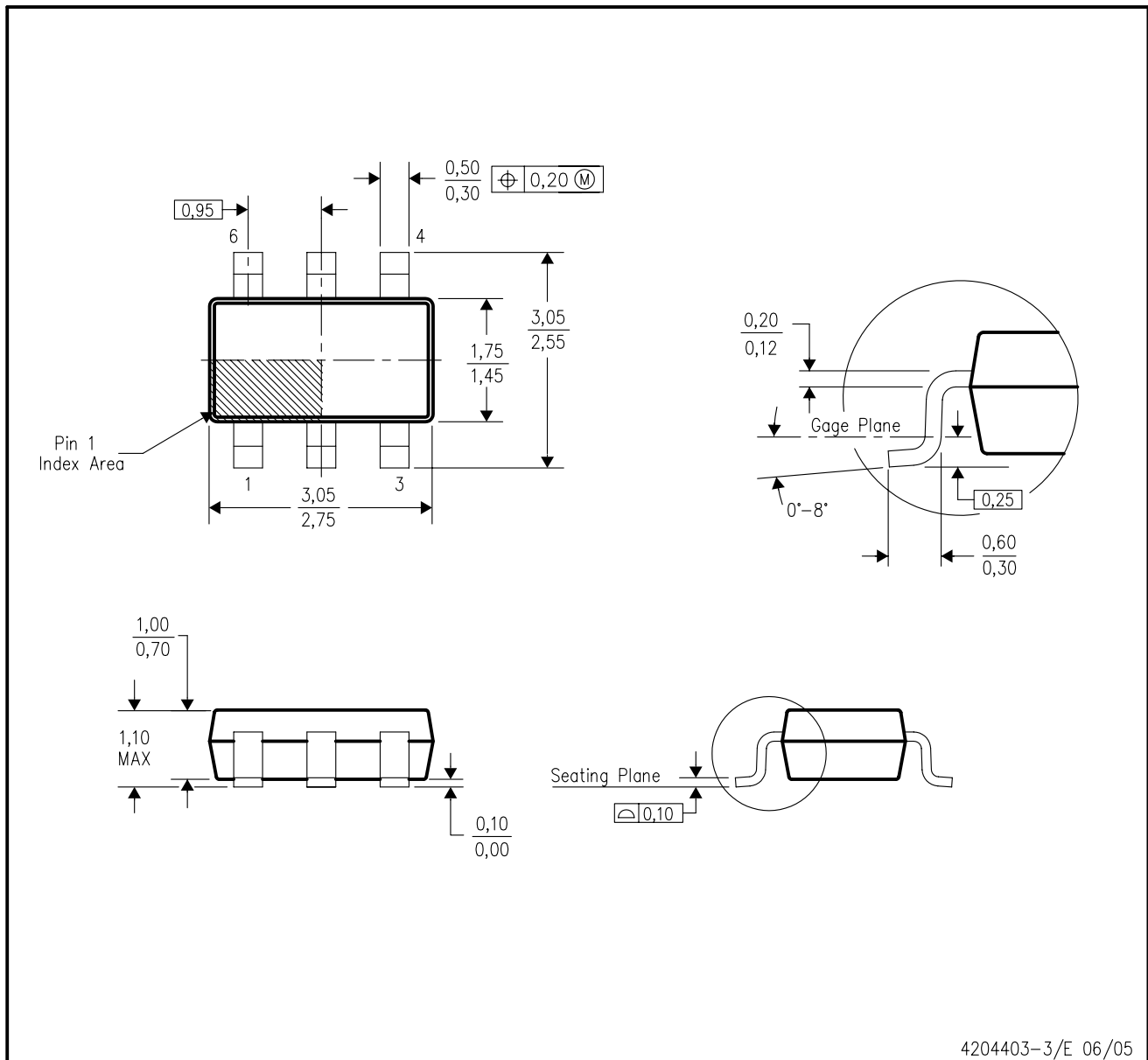

- NOTES:
- All linear dimensions are in millimeters.
  - This drawing is subject to change without notice.
  - Body dimensions do not include mold flash or protrusion.
  - Falls within JEDEC MO-193 variation AA (6 pin).

DDC (R-PDSO-G6)

PLASTIC SMALL OUTLINE

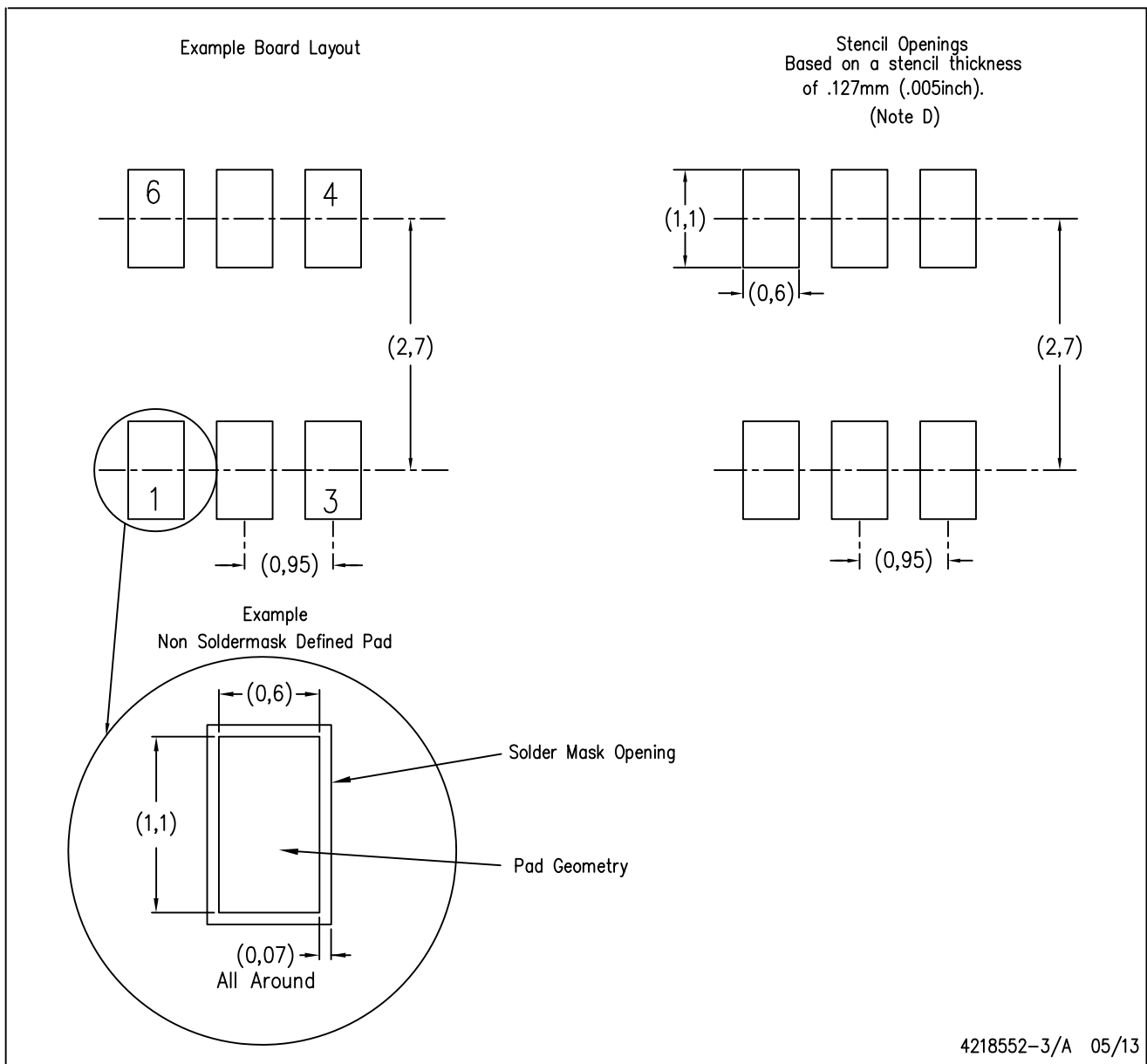

- NOTES:
- A. All linear dimensions are in millimeters.
  - B. This drawing is subject to change without notice.
  - C. Publication IPC-7351 is recommended for alternate designs.
  - D. Laser cutting apertures with trapezoidal walls and also rounding corners will offer better paste release. Customers should contact their board assembly site for stencil design recommendations. Example stencil design based on a 50% volumetric metal load solder paste. Refer to IPC-7525 for other stencil recommendations.

## IMPORTANT NOTICE AND DISCLAIMER

TI PROVIDES TECHNICAL AND RELIABILITY DATA (INCLUDING DATASHEETS), DESIGN RESOURCES (INCLUDING REFERENCE DESIGNS), APPLICATION OR OTHER DESIGN ADVICE, WEB TOOLS, SAFETY INFORMATION, AND OTHER RESOURCES "AS IS" AND WITH ALL FAULTS, AND DISCLAIMS ALL WARRANTIES, EXPRESS AND IMPLIED, INCLUDING WITHOUT LIMITATION ANY IMPLIED WARRANTIES OF MERCHANTABILITY, FITNESS FOR A PARTICULAR PURPOSE OR NON-INFRINGEMENT OF THIRD PARTY INTELLECTUAL PROPERTY RIGHTS.

These resources are intended for skilled developers designing with TI products. You are solely responsible for (1) selecting the appropriate TI products for your application, (2) designing, validating and testing your application, and (3) ensuring your application meets applicable standards, and any other safety, security, or other requirements. These resources are subject to change without notice. TI grants you permission to use these resources only for development of an application that uses the TI products described in the resource. Other reproduction and display of these resources is prohibited. No license is granted to any other TI intellectual property right or to any third party intellectual property right. TI disclaims responsibility for, and you will fully indemnify TI and its representatives against, any claims, damages, costs, losses, and liabilities arising out of your use of these resources.

TI's products are provided subject to TI's Terms of Sale ([www.ti.com/legal/termsofsale.html](http://www.ti.com/legal/termsofsale.html)) or other applicable terms available either on [ti.com](http://ti.com) or provided in conjunction with such TI products. TI's provision of these resources does not expand or otherwise alter TI's applicable warranties or warranty disclaimers for TI products.

Mailing Address: Texas Instruments, Post Office Box 655303, Dallas, Texas 75265  
Copyright © 2019, Texas Instruments Incorporated

## Looking for pricing, stock, or lifecycle information?

Click below to explore more details on WIN SOURCE:

 [View LM3405XMKX/NOPB on WIN SOURCE](#)

 [Texas Instruments](#) Information

## Optimize Your Supply Chain with WIN SOURCE Solutions

-  Global Sourcing Solution
-  Obsolete Management
-  Cost Control Management
-  Shortage Management
-  Alternative Solution
-  Excess Inventory Management