



**THE DATASHEET OF
LM3404HVMRX/NOPB**



LM3404xx 1-A Constant Current Buck Regulator for Driving High Power LEDs

1 Features

- Integrated 1-A MOSFET
- V_{IN} Range 6 V to 42 V (LM3404)
- V_{IN} Range 6 V to 75 V (LM3404HV)
- 1.2-A Output Current Overtemperature
- Cycle-by-Cycle Current Limit
- No Control Loop Compensation Required
- Separate PWM Dimming and Low Power Shutdown
- Supports All-Ceramic Output Capacitors and Capacitor-less Outputs
- Thermal Shutdown Protection
- SOIC-8 Package, SO PowerPAD™-8 Package

2 Applications

- LED Drivers
- Constant Current Sources
- Automotive Lighting
- General Illumination
- Industrial Lighting

3 Description

The LM3404 and LM3404HV devices are monolithic switching regulators designed to deliver constant currents to high power LEDs. Ideal for automotive, industrial, and general lighting applications, these devices contain a high-side N-channel MOSFET switch with a current limit of 1.5-A (typical) for step-down (Buck) regulators. Hysteretic controlled on-time and an external resistor allow the converter output voltage to adjust as needed to deliver a constant current to series and series-parallel connected LED arrays of varying number and type. Some features are: LED dimming using pulse width modulation (PWM), broken or open LED protection, low-power shutdown, and thermal shutdown.

Device Information⁽¹⁾

PART NUMBER	PACKAGE	BODY SIZE (NOM)
LM3404, LM3404HV	SOIC (8)	3.91 mm × 4.90 mm
	SO PowerPAD (8)	3.90 mm × 4.89 mm

(1) For all available packages, see the orderable addendum at the end of the data sheet.

Typical Application Diagram

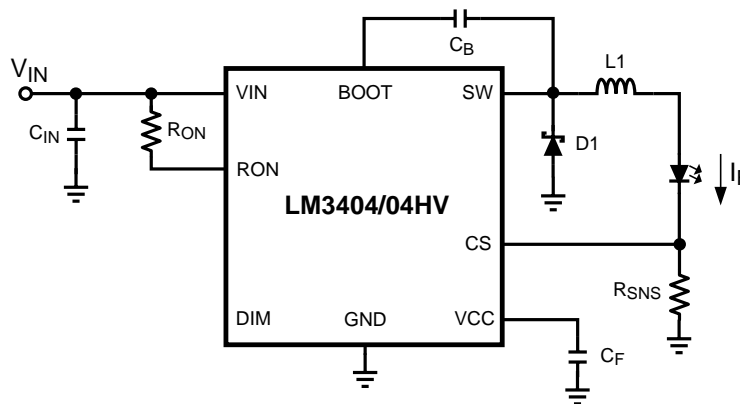

Table of Contents

1 Features 1 2 Applications 1 3 Description 1 4 Revision History 2 5 Pin Configuration and Functions 3 6 Specifications 4 6.1 Absolute Maximum Ratings 4 6.2 ESD Ratings..... 4 6.3 Recommended Operating Conditions 4 6.4 Thermal Information 5 6.5 Electrical Characteristics..... 5 6.6 Switching Characteristics 6 6.7 Typical Characteristics 7 7 Detailed Description 10 7.1 Overview 10 7.2 Functional Block Diagram 10 7.3 Feature Description..... 11	7.4 Device Functional Modes..... 14 8 Application and Implementation 15 8.1 Application Information..... 15 8.2 Typical Applications 23 9 Power Supply Recommendations 32 10 Layout 32 10.1 Layout Guidelines 32 10.2 Layout Example 33 11 Device and Documentation Support 34 11.1 Device Support 34 11.2 Related Links 34 11.3 Community Resources..... 34 11.4 Trademarks 34 11.5 Electrostatic Discharge Caution..... 34 11.6 Glossary 34 12 Mechanical, Packaging, and Orderable Information 34
---	--

4 Revision History

NOTE: Page numbers for previous revisions may differ from page numbers in the current version.

Changes from Revision F (May 2013) to Revision G	Page
<ul style="list-style-type: none"> • Added <i>ESD Ratings</i> table, <i>Feature Description</i> section, <i>Device Functional Modes</i>, <i>Application and Implementation</i> section, <i>Power Supply Recommendations</i> section, <i>Layout</i> section, <i>Device and Documentation Support</i> section, and <i>Mechanical, Packaging, and Orderable Information</i> section. 	1

Changes from Revision E (May 2013) to Revision F	Page
<ul style="list-style-type: none"> • Changed layout of National Data Sheet to TI format 	31

5 Pin Configuration and Functions

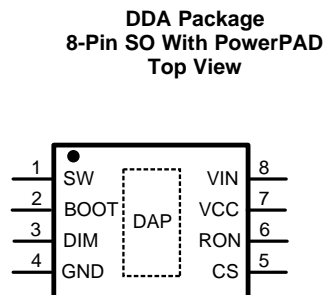
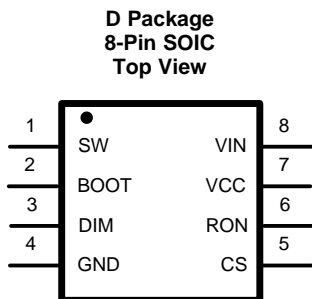

Pin Functions

PIN		I/O	DESCRIPTION
NAME	NO.		
SW	1	O	Switch pin. Connect this pin to the output inductor and Schottky diode.
BOOT	2	O	MOSFET drive bootstrap pin. Connect a 10-nF ceramic capacitor from this pin to SW.
DIM	3	I	Input for PWM dimming. Connect a logic-level PWM signal to this pin to enable and disable the power MOSFET and reduce the average light output of the LED array.
GND	4	—	Ground pin. Connect this pin to system ground.
CS	5	I	Current sense feedback pin. Set the current through the LED array by connecting a resistor from this pin to ground.
RON	6	I	On-time control pin. A resistor connected from this pin to VIN sets the regulator controlled on-time.
VCC	7	O	Output of the internal 7-V linear regulator. Bypass this pin to ground with a minimum 0.1- μ F ceramic capacitor with X5R or X7R dielectric.
VIN	8	I	Input voltage pin. Nominal operating input range for this pin is 6 V to 42 V (LM3404) or 6 V to 75 V (LM3404HV).
DAP		—	PowerPAD. Connect to ground. Place 4-6 vias from DAP to bottom layer ground plane.

6 Specifications

6.1 Absolute Maximum Ratings

 over operating free-air temperature range (unless otherwise noted)⁽¹⁾⁽²⁾

		MIN	MAX	UNIT
VIN to GND	LM3404	-0.3	45	V
	LM3404HV	-0.3	76	
BOOT to GND	LM3404	-0.3	59	V
	LM3404HV	-0.3	90	
SW to GND	LM3404	-1.5	45	V
	LM3404HV	-1.5	76	
BOOT to VCC	LM3404	-0.3	45	V
	LM3404HV	-0.3	76	
BOOT to SW		-0.3	14	V
VCC to GND		-0.3	14	V
DIM to GND		-0.3	7	V
CS to GND		-0.3	7	V
RON to GND		-0.3	7	V
Soldering information	Lead temperature (soldering, 10 s)		260	°C
	Infrared or convection reflow (15 s)		235	
Junction temperature			150	°C
Storage temperature		-65	125	°C

- Stresses beyond those listed under *Absolute Maximum Ratings* may cause permanent damage to the device. These are stress ratings only, which do not imply functional operation of the device at these or any other conditions beyond those indicated under *Recommended Operating Conditions*. Exposure to absolute-maximum-rated conditions for extended periods may affect device reliability.
- If Military or Aerospace specified devices are required, contact the Texas Instruments Semiconductor Sales Office or Distributors for availability and specifications.

6.2 ESD Ratings

		VALUE	UNIT
V _(ESD) Electrostatic discharge	Human-body model (HBM), per ANSI/ESDA/JEDEC JS-001 ⁽¹⁾⁽²⁾	±2000	V
	Charged-device model (CDM), per JEDEC specification JESD22-C101 ⁽³⁾	±1000	

- JEDEC document JEP155 states that 500-V HBM allows safe manufacturing with a standard ESD control process.
- The human body model is a 100-pF capacitor discharged through a 1.5-kΩ resistor into each pin.
- JEDEC document JEP157 states that 250-V CDM allows safe manufacturing with a standard ESD control process.

6.3 Recommended Operating Conditions

 over operating free-air temperature range (unless otherwise noted)⁽¹⁾

		MIN	NOM	MAX	UNIT
V _{IN}	LM3404	6		42	V
	LM3404HV	6		75	
Junction Temperature Range	LM3404	-40		125	°C
	LM3404HV	-40		125	

- Absolute Maximum Ratings* indicate limits beyond which damage to the device may occur. *Recommended Operating Conditions* indicate conditions for which the device is intended to be functional, but specific performance is **not** ensured. For specifications and the test conditions, see *Electrical Characteristics*.

6.4 Thermal Information

THERMAL METRIC ⁽¹⁾		LM3404, LM3404HV		UNIT
		SOIC	SO PowerPAD	
		8 PINS	8 PINS	
R _{θJA}	Junction-to-ambient thermal resistance	106.8	44.7	°C/W
R _{θJC(top)}	Junction-to-case (top) thermal resistance	46.2	51.2	°C/W
R _{θJB}	Junction-to-board thermal resistance	48.7	24.5	°C/W
ψ _{JT}	Junction-to-top characterization parameter	6.7	6.8	°C/W
ψ _{JB}	Junction-to-board characterization parameter	48	24.4	°C/W
R _{θJC(bot)}	Junction-to-case (bottom) thermal resistance	N/A	2.6	°C/W

(1) For more information about traditional and new thermal metrics, see the *Semiconductor and IC Package Thermal Metrics* application report, [SPRA953](#).

6.5 Electrical Characteristics

V_{IN} = 24 V (unless otherwise noted).

–40°C ≤ T_J ≤ 125°C. ⁽¹⁾

PARAMETER	CONDITIONS	MIN	TYP	MAX	UNIT	
REGULATION AND OVERVOLTAGE COMPARATORS						
V _{REF-REG}	CS Regulation Threshold	CS Decreasing, SW turns on	194	200	206	mV
V _{REF-OV}	CS Overvoltage Threshold	CS Increasing, SW turns off		300		mV
I _{CS}	CS Bias Current	CS = 0 V		0.1		μA
SHUTDOWN						
V _{SD-TH}	Shutdown Threshold	R _{ON} / SD Increasing	0.3	0.7	1.05	V
V _{SD-HYS}	Shutdown Hysteresis	R _{ON} / SD Decreasing		40		mV
INTERNAL REGULATOR						
V _{CC-REG}	V _{CC} Regulated Output		6.4	7	7.4	V
V _{IN-DO}	V _{IN} – V _{CC}	I _{CC} = 5 mA, 6 V < V _{IN} < 8 V		300		mV
V _{CC-BP-TH}	V _{CC} Bypass Threshold	V _{IN} Increasing		8.8		V
V _{CC-BP-HYS}	V _{CC} Bypass Hysteresis	V _{IN} Decreasing		230		mV
V _{CC-Z-6}	V _{CC} Output Impedance (0 mA < I _{CC} < 5 mA)	V _{IN} = 6 V		55		Ω
V _{CC-Z-8}		V _{IN} = 8 V		50		Ω
V _{CC-Z-24}		V _{IN} = 24 V		0.4		Ω
V _{CC-LIM}	V _{CC} Current Limit ⁽²⁾	V _{IN} = 24 V, V _{CC} = 0 V		16		mA
V _{CC-UV-TH}	V _{CC} Undervoltage Lock-out Threshold	V _{CC} Increasing		5.3		V
V _{CC-UV-HYS}	V _{CC} Undervoltage Lock-out Hysteresis	V _{CC} Decreasing		150		mV
V _{CC-UV-DLY}	V _{CC} Undervoltage Lock-out Filter Delay	100-mV Overdrive		3		μs
I _{IN-OP}	I _{IN} Operating Current	Non-switching, CS = 0.5 V		625	900	μA
I _{IN-SD}	I _{IN} Shutdown Current	R _{ON} / SD = 0 V		95	180	μA

(1) Typical specifications represent the most likely parametric norm at 25°C operation.

(2) V_{CC} provides self bias for the internal gate drive and control circuits. Device thermal limitations limit external loading.

Electrical Characteristics (continued)

$V_{IN} = 24\text{ V}$ (unless otherwise noted).
 $-40^{\circ}\text{C} \leq T_J \leq 125^{\circ}\text{C}$. ⁽¹⁾

PARAMETER	CONDITIONS	MIN	TYP	MAX	UNIT
CURRENT LIMIT					
I_{LIM} Current Limit Threshold		1.2	1.5	1.8	A
DIM COMPARATOR					
V_{IH} Logic High	DIM Increasing	2.2			V
V_{IL} Logic Low	DIM Decreasing			0.8	V
I_{DIM-PU} DIM Pullup Current	DIM = 1.5 V		80		μA
MOSFET AND DRIVER					
R_{DS-ON} Buck Switch On Resistance	$I_{SW} = 200\text{ mA}$, BST-SW = 6.3 V		0.37	0.75	Ω
$V_{DR-UVLO}$ BST Undervoltage Lock-out Threshold	BST-SW Increasing	1.7	3	4	V
V_{DR-HYS} BST Undervoltage Lock-out Hysteresis	BST-SW Decreasing		400		mV
THERMAL SHUTDOWN					
T_{SD} Thermal Shutdown Threshold			165		$^{\circ}\text{C}$
T_{SD-HYS} Thermal Shutdown Hysteresis			25		$^{\circ}\text{C}$

6.6 Switching Characteristics

over operating free-air temperature range (unless otherwise noted)

PARAMETER	TEST CONDITIONS	MIN	TYP	MAX	UNIT
SYSTEM PARAMETERS - LM3404					
t_{ON-1} On-time 1	$V_{IN} = 10\text{ V}$, $R_{ON} = 200\text{ k}\Omega$	2.1	2.75	3.4	μs
t_{ON-2} On-time 2	$V_{IN} = 40\text{ V}$, $R_{ON} = 200\text{ k}\Omega$	515	675	835	ns
SYSTEM PARAMETERS - LM3404HV					
t_{ON-1} On-time 1	$V_{IN} = 10\text{ V}$, $R_{ON} = 200\text{ k}\Omega$	2.1	2.75	3.4	μs
t_{ON-2} On-time 2	$V_{IN} = 70\text{ V}$, $R_{ON} = 200\text{ k}\Omega$	325	415	505	ns
OFF TIMER					
$t_{OFF-MIN}$ Minimum Off-time	CS = 0 V		270		ns

6.7 Typical Characteristics

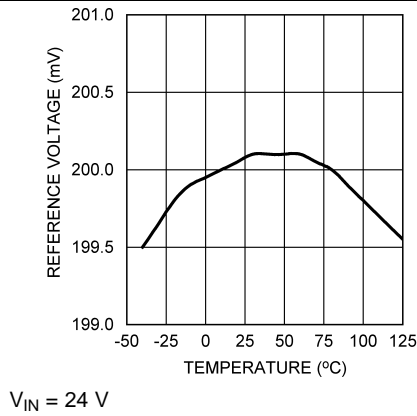

Figure 1. V_{REF} vs Temperature

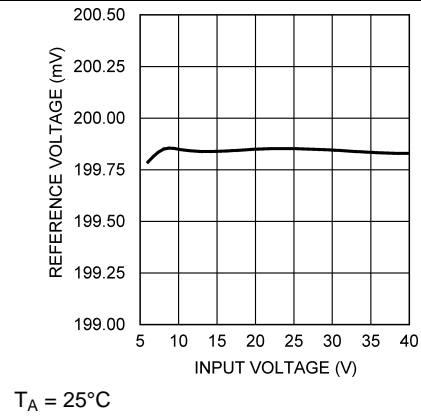

Figure 2. V_{REF} vs V_{IN} , LM3404

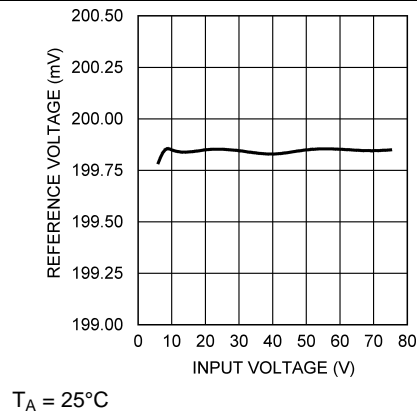

Figure 3. V_{REF} vs V_{IN} , LM3404HV

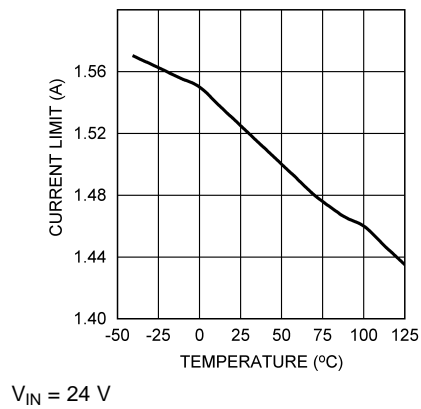

Figure 4. Current Limit vs Temperature

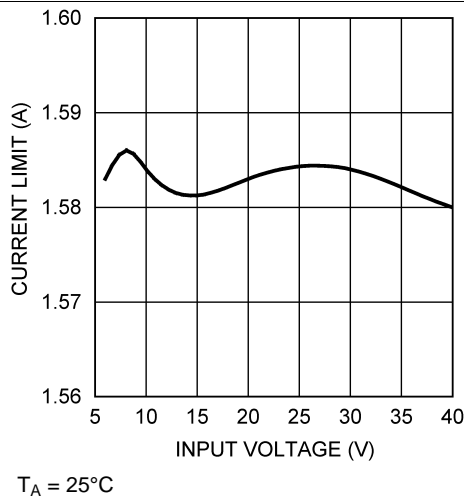

Figure 5. Current Limit vs V_{IN} , LM3404

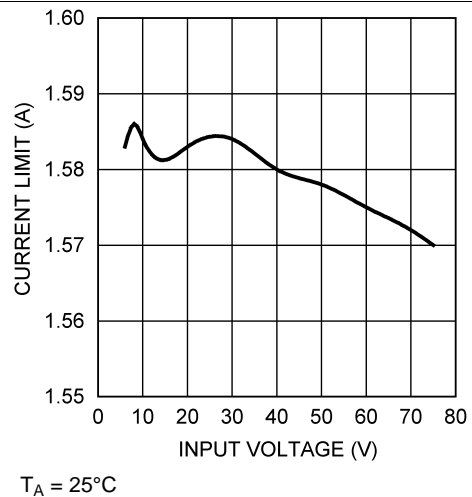
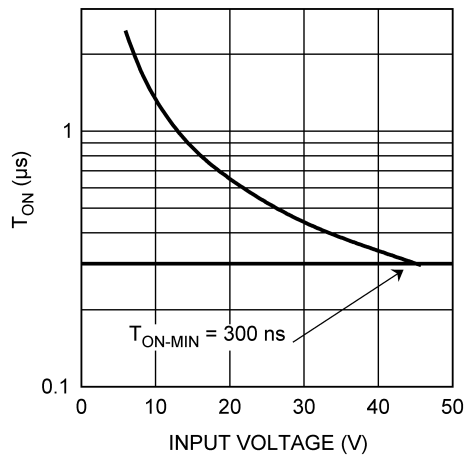

Figure 6. Current Limit vs V_{IN} , LM3404HV

Typical Characteristics (continued)



T_A = 25°C

Figure 7. T_{ON} vs V_{IN}, R_{ON} = 100 kΩ

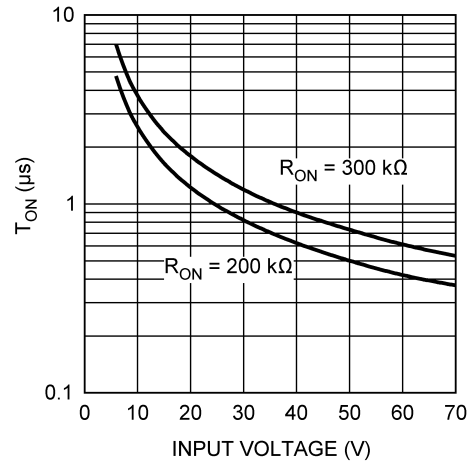

T_A = 25°C

Figure 8. T_{ON} vs V_{IN}

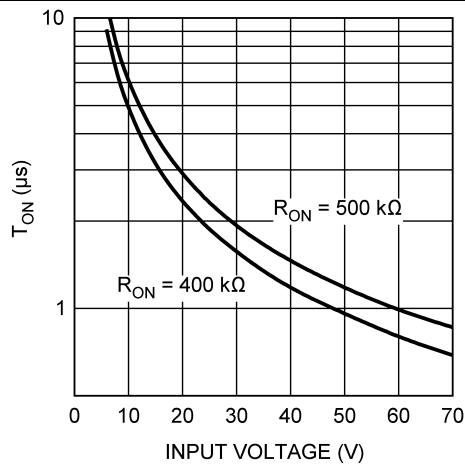

T_A = 25°C

Figure 9. T_{ON} vs V_{IN}

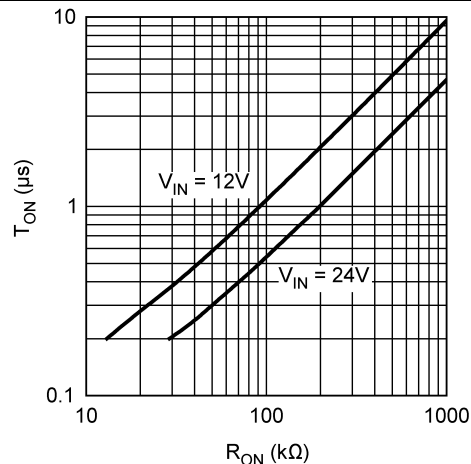

T_A = 25°C

Figure 10. T_{ON} vs R_{ON}, LM3404

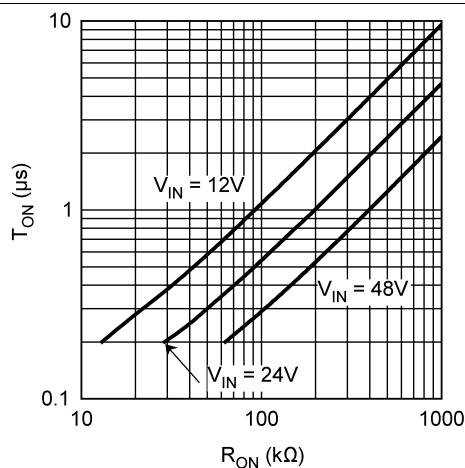

T_A = 25°C

Figure 11. T_{ON} vs R_{ON}, LM3404HV

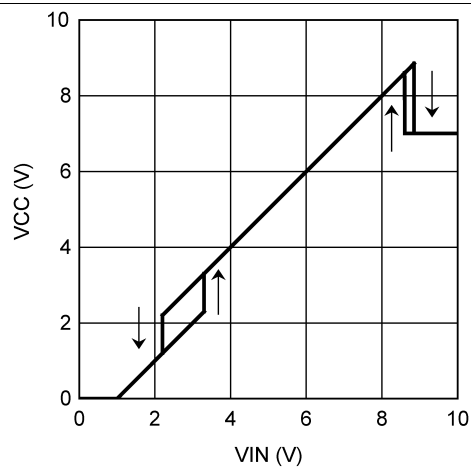

T_A = 25°C

Figure 12. V_{CC} vs V_{IN}

Typical Characteristics (continued)

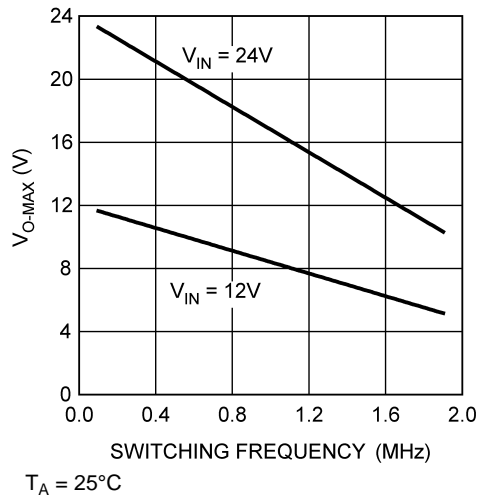

Figure 13. V_{O-MAX} vs f_{SW} , LM3404

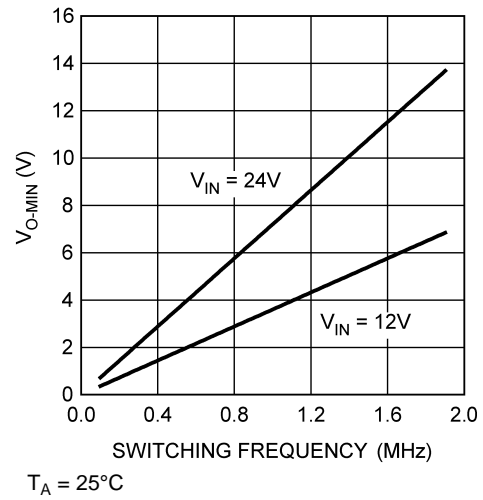

Figure 14. V_{O-MIN} vs f_{SW} , LM3404

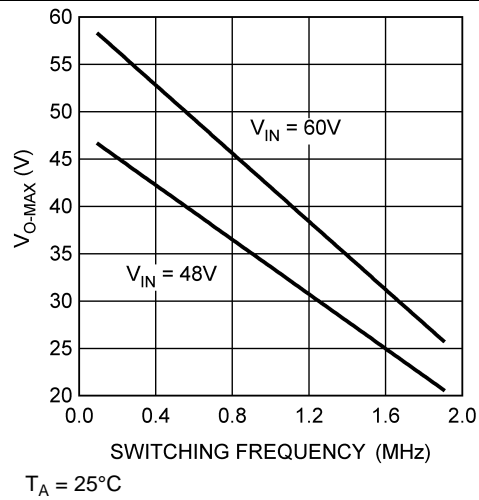

Figure 15. V_{O-MAX} vs f_{SW} , LM3404HV

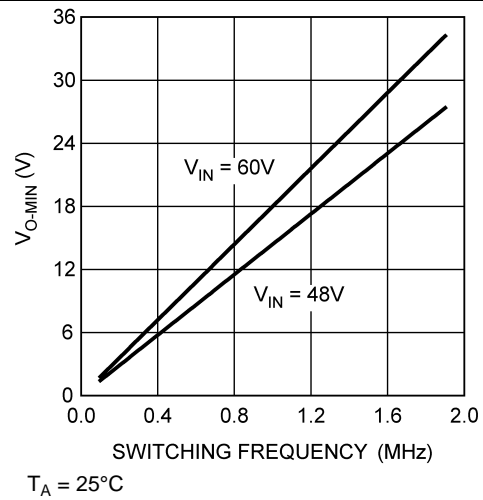

Figure 16. V_{O-MIN} vs f_{SW} , LM3404HV

Feature Description (continued)

7.3.3 Maximum Output Voltage

The 300-ns minimum off-time limits the maximum duty cycle of the converter, D_{MAX} , and in turn the maximum output voltage, $V_{O(MAX)}$, is determined by [Equation 5](#).

$$D_{MAX} = \frac{t_{ON}}{t_{ON} + t_{OFF-MIN}}$$

$$V_{O(max)} = D_{MAX} \times V_{IN} \quad (5)$$

The maximum number of LEDs, n_{MAX} , that can be placed in a single series string is governed by $V_{O(MAX)}$ and the maximum forward voltage of the LEDs used, $V_{F(MAX)}$, using [Equation 6](#).

$$n_{MAX} = \frac{V_{O(max)} - 200 \text{ mV}}{V_{F(MAX)}} \quad (6)$$

At low switching frequency, the maximum duty cycle and output voltage are higher, allowing the LM3404 and LM3404HV devices to regulate output voltages that are nearly equal to input voltage. [Equation 7](#) relates switching frequency to maximum output voltage, and is also shown graphically in [Typical Characteristics](#):

$$V_{O(MAX)} = V_{IN} \times \frac{T_{SW} - 300 \text{ ns}}{T_{SW}}$$

$$T_{SW} = 1/f_{SW} \quad (7)$$

7.3.4 Minimum Output Voltage

The minimum recommended on-time for the LM3404 and LM3404HV devices is 300 ns. This lower limit for t_{ON} determines the minimum duty cycle and output voltage that can be regulated based on input voltage and switching frequency. The relationship is determined by [Equation 8](#), shown on the same graphs as maximum output voltage in [Typical Characteristics](#):

$$V_{O(MIN)} = V_{IN} \times \frac{300 \text{ ns}}{T_{SW}} \quad (8)$$

7.3.5 High Voltage Bias Regulator

The LM3404 and LM3404HV devices contain an internal linear regulator with a 7-V output, connected between the VIN and the VCC pins. The VCC pin must be bypassed to the GND pin with a 0.1- μ F ceramic capacitor connected as close as possible to the pins of the IC. VCC tracks VIN until VIN reaches 8.8 V (typical) and then regulates at 7 V as VIN increases. Operation begins when VCC crosses 5.25 V.

7.3.6 Internal MOSFET and Driver

The LM3404 and LM3404HV devices feature an internal power MOSFET as well as a floating driver connected from the SW pin to the BOOT pin. Both rise time and fall time are 20-ns each (typical) and the approximate gate charge is 6 nC. The high-side rail for the driver circuitry uses a bootstrap circuit consisting of an internal high-voltage diode and an external 10-nF capacitor, C_B . V_{CC} charges C_B through the internal diode while the power MOSFET is off. When the MOSFET turns on, the internal diode reverse biases. This creates a floating supply equal to the V_{CC} voltage minus the diode drop to drive the MOSFET when its source voltage is equal to V_{IN} .

Feature Description (continued)

7.3.7 Fast Shutdown for PWM Dimming

The DIM pin of the LM3404 and LM3404HV devices is a TTL compatible input for low-frequency PWM dimming of the LED. A logic low (below 0.8 V) at DIM will disable the internal MOSFET and shut off the current flow to the LED array. While the DIM pin is in a logic low state the support circuitry (driver, bandgap, VCC) remains active to minimize the time needed to turn the LED array back on when the DIM pin sees a logic high (above 2.2 V). A 75- μ A (typical) pullup current ensures that the LM3404 and LM3404HV devices are on when DIM pin is open circuited, eliminating the need for a pullup resistor. Dimming frequency, f_{DIM} , and duty cycle, D_{DIM} , are limited by the LED current rise time and fall time and the delay from activation of the DIM pin to the response of the internal power MOSFET. In general, f_{DIM} must be at least one order of magnitude lower than the steady state switching frequency to prevent aliasing.

7.3.8 Peak Current Limit

The current limit comparator of the LM3404 and LM3404HV devices will engage whenever the power MOSFET current (equal to the inductor current while the MOSFET is on) exceeds 1.5-A (typical). The power MOSFET is disabled for a cool-down time that is approximately 75 \times the steady-state on-time. At the conclusion of this cool-down time the system restarts. If the current limit condition persists the cycle of cool-down time and restarting will continue, creating a low-power hiccup mode, minimizing thermal stress on the LM3404 and LM3404HV devices and the external circuit components.

7.3.9 Overvoltage and Overcurrent Comparator

The CS pin includes an output overvoltage and overcurrent comparator that will disable the power MOSFET whenever V_{SNS} exceeds 300 mV. This threshold provides a hard limit for the output current. Output current overshoot is limited to $300 \text{ mV} / R_{SNS}$ by this comparator during transients.

The OVP/OCP comparator can also be used to prevent the output voltage from rising to $V_{O(MAX)}$ in the event of an output open-circuit. This is the most common failure mode for LEDs, due to breaking of the bond wires. In a current regulator an output open circuit causes V_{SNS} to fall to zero, commanding maximum duty cycle. Figure 18 shows a method using a Zener diode, Z1, and Zener limiting resistor, R_Z , to limit output voltage to the reverse breakdown voltage of Z1 plus 200 mV. The Zener diode reverse breakdown voltage, V_Z , must be greater than the maximum combined V_F of all LEDs in the array. The maximum recommended value for R_Z is 1 k Ω .

As discussed in [Maximum Output Voltage](#), there is a limit to how high V_O can rise during an output open-circuit that is always less than V_{IN} . If no output capacitor is used, the output stage of the LM3404 and LM3404HV devices is capable of withstanding $V_{O(MAX)}$ indefinitely; however, the voltage at the output end of the inductor will oscillate and can go above V_{IN} or below 0 V. A small (typically 10 nF) capacitor across the LED array dampens this oscillation. For circuits that use an output capacitor, the system can still withstand $V_{O(MAX)}$ indefinitely as long as C_O is rated to handle V_{IN} . The high current paths are blocked in output open-circuit and the risk of thermal stress is minimal, hence the user may opt to allow the output voltage to rise in the case of an open-circuit LED failure.

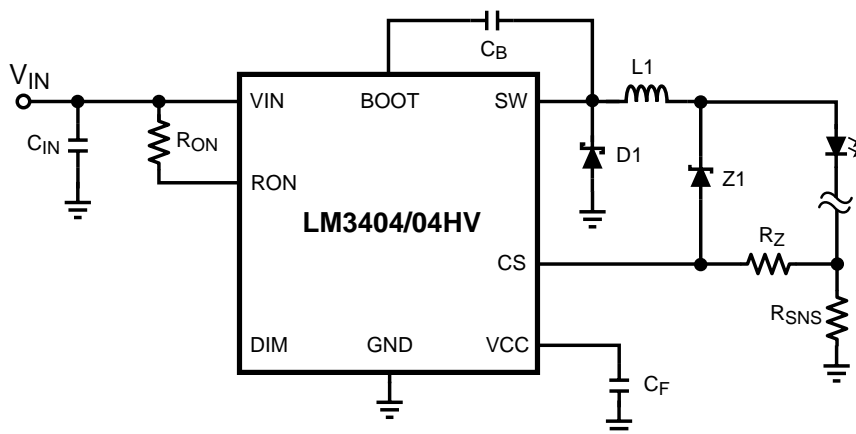

Figure 18. Output Open-Circuit Protection

7.4 Device Functional Modes

7.4.1 Low-Power Shutdown

The LM3404 and LM3404HV devices can be placed into a low-power state ($I_{IN-SD} = 90 \mu A$) by grounding the RON pin with a signal-level MOSFET as shown in Figure 19. Low-power MOSFETs like the 2N7000, 2N3904, or equivalent are recommended devices for putting the LM3404 and LM3404HV devices into low-power shutdown. Logic gates can also be used to shut down the LM3404 LM3404HV devices as long as the logic low voltage is below the over temperature minimum threshold of 0.3 V. Noise filter circuitry on the RON pin can cause a few pulses with longer on-times than normal after RON is grounded or released. In these cases, the OVP/OCV comparator will ensure that the peak inductor or LED current does not exceed $300 \text{ mV} / R_{SNS}$.

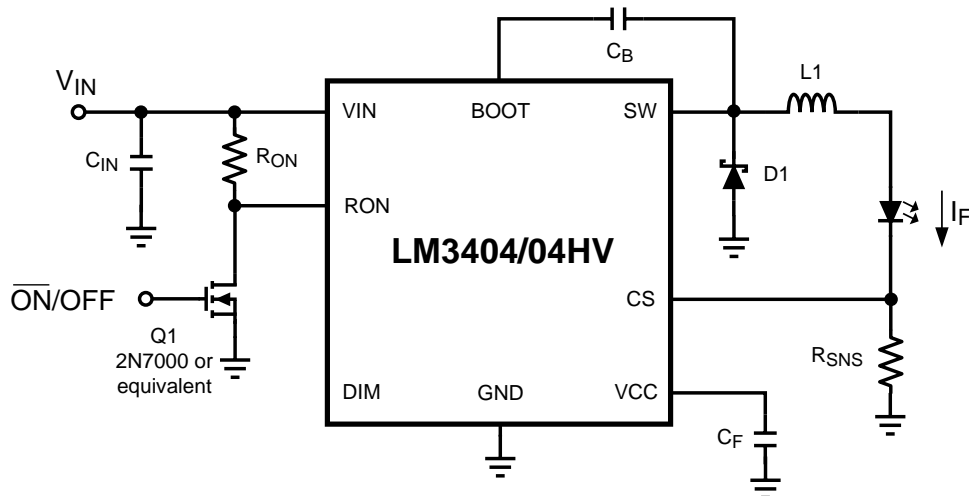

Figure 19. Low-Power Shutdown

7.4.2 Thermal Shutdown

Internal thermal shutdown circuitry is provided to protect the IC in the event that the maximum junction temperature is exceeded. The threshold for thermal shutdown is 165°C with a 25°C hysteresis (both values typical). During thermal shutdown the MOSFET and driver are disabled.

8 Application and Implementation

NOTE

Information in the following applications sections is not part of the TI component specification, and TI does not warrant its accuracy or completeness. TI's customers are responsible for determining suitability of components for their purposes. Customers should validate and test their design implementation to confirm system functionality.

8.1 Application Information

8.1.1 Switching Frequency

Switching frequency is selected based on the trade-offs between efficiency (better at low frequency), solution size and cost (smaller at high frequency), and the range of output voltage that can be regulated (wider at lower frequency). Many applications place limits on switching frequency due to EMI sensitivity. The on-time of the LM3404 and LM3404HV devices can be programmed for switching frequencies ranging from the 10's of kHz to over 1 MHz. The maximum switching frequency is limited only by the minimum on-time and minimum off-time requirements.

8.1.2 LED Ripple Current

Selection of the ripple current, Δi_F , through the LED array is analogous to the selection of output ripple voltage in a standard voltage regulator. Where the output ripple in a voltage regulator is commonly $\pm 1\%$ to $\pm 5\%$ of the DC output voltage, LED manufacturers generally recommend values for Δi_F ranging from $\pm 5\%$ to $\pm 20\%$ of I_F . Higher LED ripple current allows the use of smaller inductors, smaller output capacitors, or no output capacitors at all. The advantages of higher ripple current are reduction in the solution size and cost. Lower ripple current requires more output inductance, higher switching frequency, or additional output capacitance. The advantages of lower ripple current are a reduction in heating in the LED itself and greater tolerance in the average LED current before the current limit of the LED or the driving circuitry is reached.

8.1.3 Buck Converters Without Output Capacitors

The buck converter is unique among non-isolated topologies because of the direct connection of the inductor to the load during the entire switching cycle. By definition an inductor will control the rate of change of current that flows through it, and this control overcurrent ripple forms the basis for component selection in both voltage regulators and current regulators. A current regulator such as the LED driver for which the LM3404 and LM3404HV devices was designed focuses on the control of the current through the load, not the voltage across it. A constant current regulator is free of load current transients, and has no need of output capacitance to supply the load and maintain output voltage. Referring to [Typical Application Diagram](#) on the front page of this data sheet, the inductor and LED can form a single series chain, sharing the same current. When no output capacitor is used, the same equations that govern inductor ripple current, Δi_L , also apply to the LED ripple current, Δi_F . For a controlled on-time converter such as the LM3404 and LM3404HV devices, the ripple current is described by [Equation 9](#).

$$\Delta i_L = \Delta i_F = \frac{V_{IN} - V_O}{L} t_{ON} \quad (9)$$

A minimum ripple voltage of 25 mV is recommended at the CS pin to provide good signal to noise ratio (SNR). The CS pin ripple voltage, Δv_{SNS} , is described by [Equation 10](#).

$$\Delta v_{SNS} = \Delta i_F \times R_{SNS} \quad (10)$$

Application Information (continued)

8.1.4 Buck Converters With Output Capacitors

A capacitor placed in parallel with the LED or array of LEDs can be used to reduce the LED current ripple while keeping the same average current through both the inductor and the LED array. This technique is demonstrated in Design Examples 1 and 2. With this topology the output inductance can be lowered, making the magnetics smaller and less expensive. Alternatively, the circuit could be run at lower frequency but keep the same inductor value, improving the efficiency and expanding the range of output voltage that can be regulated. Both the peak current limit and the OVP/OCP comparator still monitor peak inductor current, placing a limit on how large Δi_L can be even if Δi_F is made very small. A parallel output capacitor is also useful in applications where the inductor or input voltage tolerance is poor. Adding a capacitor that reduces Δi_F to well below the target provides headroom for changes in inductance or V_{IN} that might otherwise push the peak LED ripple current too high.

Figure 20 shows the equivalent impedances presented to the inductor current ripple when an output capacitor, C_O , and its equivalent series resistance (ESR) are placed in parallel with the LED array. The entire inductor ripple current flows through R_{SNS} to provide the required 25 mV of ripple voltage for proper operation of the CS comparator.

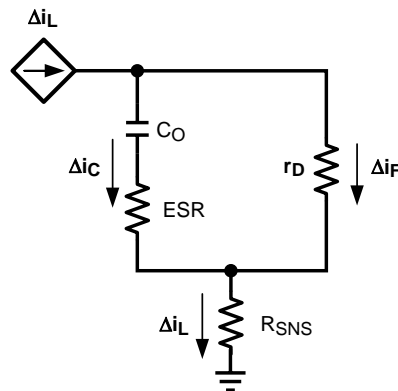

Figure 20. LED and C_O Ripple Current

To calculate the respective ripple currents the LED array is represented as a dynamic resistance, r_D . LED dynamic resistance is not always specified on the manufacturer's data sheet, but it can be calculated as the inverse slope of the LED's V_F vs. I_F curve. Dividing V_F by I_F will give an incorrect value that is 5x to 10x too high. Total dynamic resistance for a string of n LEDs connected in series can be calculated as the r_D of one device multiplied by n . Inductor ripple current is still calculated with the expression from [Buck Converters Without Output Capacitors](#). Equation 11 can then be used to estimate Δi_F when using a parallel capacitor.

$$\Delta i_F = \frac{\Delta i_L}{1 + \frac{r_D}{Z_C}}$$

$$Z_C = ESR + \frac{1}{2\pi \times f_{SW} \times C_O} \quad (11)$$

The calculation for Z_C assumes that the shape of the inductor ripple current is approximately sinusoidal.

Small values of C_O that do not significantly reduce Δi_F can also be used to control EMI generated by the switching action of the LM3404 and LM3404HV devices. EMI reduction becomes more important as the length of the connections between the LED and the rest of the circuit increase.

Application Information (continued)

8.1.5 Input Capacitors

Input capacitors at the VIN pin of the LM3404 and LM3404HV devices are selected using requirements for minimum capacitance and rms ripple current. The input capacitors supply pulses of current approximately equal to I_F while the power MOSFET is on, and are charged up by the input voltage while the power MOSFET is off. Switching converters such as the LM3404 and LM3404HV devices have a negative input impedance due to the decrease in input current as input voltage increases. This inverse proportionality of input current to input voltage can cause oscillations (sometimes called power supply interaction) if the magnitude of the negative input impedance is greater than the input filter impedance. Minimum capacitance can be selected by comparing the input impedance to the converter's negative resistance; however this requires accurate calculation of the input voltage source inductance and resistance, quantities that can be difficult to determine. An alternative method to select the minimum input capacitance, $C_{IN(MIN)}$, is to select the maximum input voltage ripple which can be tolerated. This value, $\Delta V_{IN(MAX)}$, is equal to the change in voltage across C_{IN} during the converter on-time, when C_{IN} supplies the load current. $C_{IN(MIN)}$ can be selected with [Equation 12](#).

$$C_{IN(MIN)} = \frac{I_F \times t_{ON}}{\Delta V_{IN(MAX)}} \quad (12)$$

A good starting point for selection of C_{IN} is to use an input voltage ripple of 5% to 10% of V_{IN} . TI recommends a minimum input capacitance of 2x the $C_{IN(MIN)}$ value for all LM3404 and LM3404HV circuits. To determine the rms current rating, [Equation 13](#) can be used.

$$I_{IN(rms)} = I_F \times \sqrt{D(1-D)} \quad (13)$$

Ceramic capacitors are the best choice for the input to the LM3404 and LM3404HV devices due to their high ripple current rating, low ESR, low cost, and small size compared to other types. When selecting a ceramic capacitor, special attention must be paid to the operating conditions of the application. Ceramic capacitors can lose one-half or more of their capacitance at their rated DC voltage bias and also lose capacitance with extremes in temperature. TI recommends a DC voltage rating equal to twice the expected maximum input voltage. In addition, the minimum quality dielectric which is suitable for switching power supply inputs is X5R, while X7R or better is preferred.

8.1.6 Recirculating Diode

The LM3404 and LM3404HV devices are non-synchronous buck regulators that require a recirculating diode D1 (see the [Typical Application Diagram](#)) to carrying the inductor current during the MOSFET off-time. The most efficient choice for D1 is a Schottky diode due to low forward drop and near-zero reverse recovery time. D1 must be rated to handle the maximum input voltage plus any switching node ringing when the MOSFET is on. In practice all switching converters have some ringing at the switching node due to the diode parasitic capacitance and the lead inductance. D1 must also be rated to handle the average current, I_D , calculated as shown in [Equation 14](#).

$$I_D = (1 - D) \times I_F \quad (14)$$

This calculation must be done at the maximum expected input voltage. The overall converter efficiency becomes more dependent on the selection of D1 at low duty cycles, where the recirculating diode carries the load current for an increasing percentage of the time. This power dissipation can be calculated by checking the typical diode forward voltage, V_D , from the I-V curve on the product data sheet and then multiplying it by I_D . Diode data sheets will also provide a typical junction-to-ambient thermal resistance, θ_{JA} , which can be used to estimate the operating die temperature of the device. Multiplying the power dissipation ($P_D = I_D \times V_D$) by θ_{JA} gives the temperature rise. The diode case size can then be selected to maintain the Schottky diode temperature below the operational maximum.

Application Information (continued)

8.1.7 LED Current During DIM Mode

The LM3404 contains high speed MOSFET gate drive circuitry that switches the main internal power MOSFET between on and off states. This circuitry uses current derived from the VCC regulator to charge the MOSFET during turn-on, then dumps current from the MOSFET gate to the source (the SW pin) during turn-off. As shown in [Figure 19](#), the MOSFET drive circuitry contains a gate drive undervoltage lockout (UVLO) circuit that ensures the MOSFET remains off when there is inadequate VCC voltage for proper operation of the driver. This watchdog circuitry is always running including during DIM and shutdown modes, and supplies a small amount of current from VCC to SW. Because the SW pin is connected directly to the LEDs through the buck inductor, this current returns to ground through the LEDs. The amount of current sourced is a function of the SW voltage, as shown in [Figure 21](#).

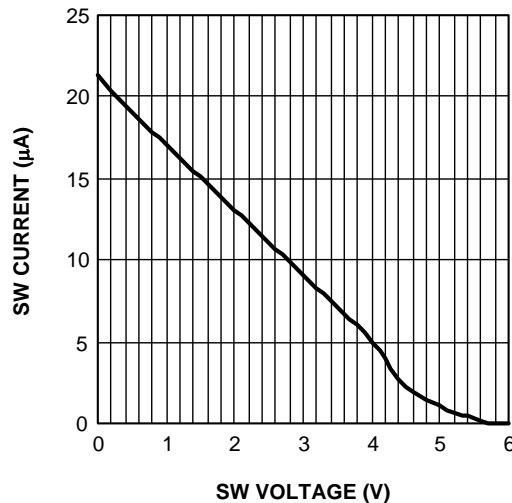

Figure 21. LED Current From SW Pin

Though most power LEDs are designed to run at several hundred milliamps, some can be seen to glow with a faint light at extremely low current levels, as low as a couple microamps in some instances. In lab testing, the forward voltage was found to be approximately 2 V for LEDs that exhibited visible light at these low current levels. For LEDs that did not show light emission at very low current levels, the forward voltage was found to be around 900 mV. It is important to remember that the forward voltage is also temperature dependent, decreasing at higher temperatures. Consequently, with a maximum Vcc voltage of 7.4 V, current will be observed in the LEDs if the total stack voltage is less than about 6 V at a forward current of several microamps. No current is observed if the stack voltage is above 6 V, as shown in [Figure 21](#). The need for absolute darkness during DIM mode is also application dependent. It will not affect regular PWM dimming operation.

The fix for this issue is extremely simple. Place a resistor from the SW pin to ground according to [Table 1](#).

Table 1. Resistor Value for Number of LEDs

NUMBER OF LEDs	RESISTOR VALUE (kΩ)
1	20
2	50
3	90
4	150
5	200
>5	300

The luminaire designer must ensure that the suggested resistor is effective in eliminating the off-state light output. A combination of calculations based on LED manufacturer data and lab measurements over temperature will ensure the best design.

8.1.8 Transient Protection Considerations

Considerations must be made when external sources, loads or connections are made to the switching converter circuit due to the possibility of electrostatic discharge (ESD) or electric over stress (EOS) events occurring and damaging the integrated circuit (IC) device. All IC device pins contain Zener based clamping structures that are meant to clamp ESD. ESD events are very low energy events, typically less than 5 μJ (microjoules). Any event that transfers more energy than this may damage the ESD structure. Damage is typically represented as a short from the pin to ground as the extreme localized heat of the ESD or EOS event causes the aluminum metal on the chip to melt, causing the short. This situation is common to all integrated circuits and not just unique to the LM3404x device.

8.1.8.1 CS Pin Protection

When hot swapping in a load (that is, test points, load boards, LED stack), any residual charge on the load will be immediately transferred through the output capacitor to the CS pin, which is then damaged as shown in Figure 22. The EOS event due to the residual charge from the load is represented as $V_{\text{TRANSIENT}}$.

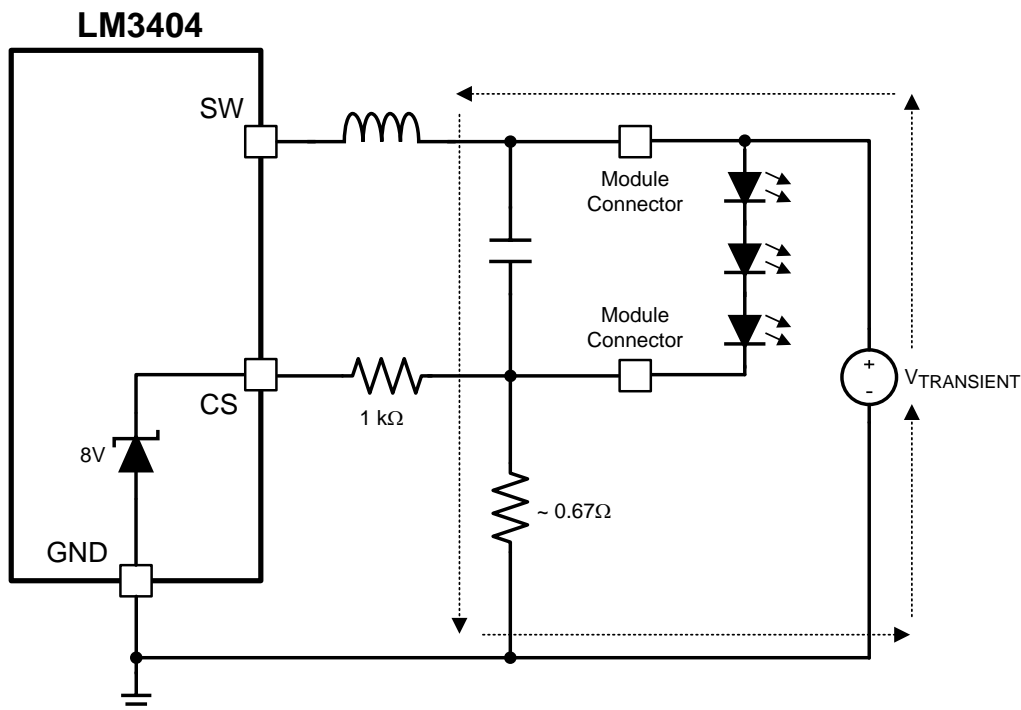

Figure 22. CS Pin, Transient Path With Protection

From measurements, we know that the 8-V ESD structure on the CS pin can typically withstand 25 mA of direct current (DC). Adding a 1-k Ω resistor in series with the CS pin, shown in Figure 22, results in the majority of the transient energy to pass through the discrete sense resistor rather than the device. The series resistor limits the peak current that can flow during a transient event, thus protecting the CS pin. With the 1-k Ω resistor shown, a 33-V, 49-A transient on the LED return connector terminal could be absorbed as calculated by:

$$V = 25 \text{ mA} \times 1 \text{ k}\Omega + 8 \text{ V} = 33 \text{ V} \quad (15)$$

$$I = 33 \text{ V} / 0.67 \Omega = 49 \text{ A} \quad (16)$$

This is an extremely high-energy event, so the protection measures previously described should be adequate to solve this issue.

Adding a resistor in series with the CS pin causes the observed output LED current to shift very slightly. The reason for this is twofold: (1) the CS pin has about 20 pF of inherent capacitance inside it, which causes a slight delay (20 ns for a 1-k Ω series resistor), and (2) the comparator that is watching the voltage at the CS pin uses a pnp bipolar transistor at its input. The base current of this pnp transistor is approximately 100 nA which will cause a 0.1-mV change in the 200-mV threshold. These are both very minor changes and are well understood. The shift in current can either be neglected or taken into consideration by changing the current sense resistance slightly.

8.1.8.2 CS Pin Protection With OVP

When designing output overvoltage protection into the switching converter circuit using a Zener diode, transient protection on the CS pin requires additional consideration. As shown in [Figure 23](#), adding a Zener diode from the output to the CS pin (with the series resistor) for output overvoltage protection will now again allow the transient energy to be passed

Adding an additional series resistor to the CS pin as shown in [Figure 24](#) will result in the majority of the transient energy to pass through the sense resistor thereby protecting the LM3404x device.

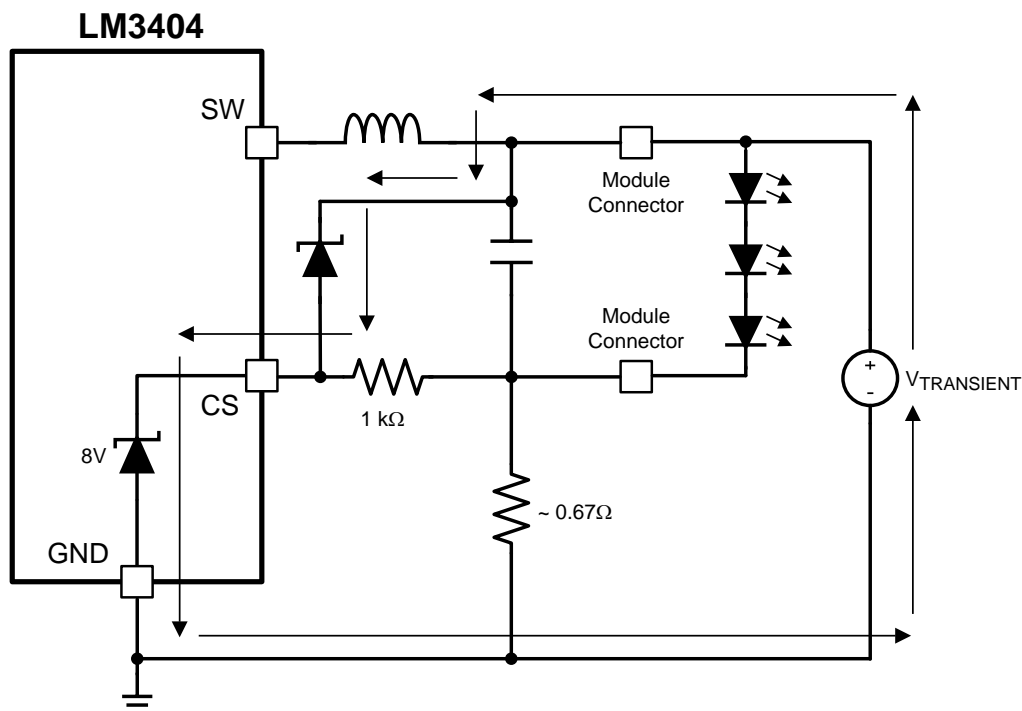

Figure 23. CS Pin With OVP, Transient Path

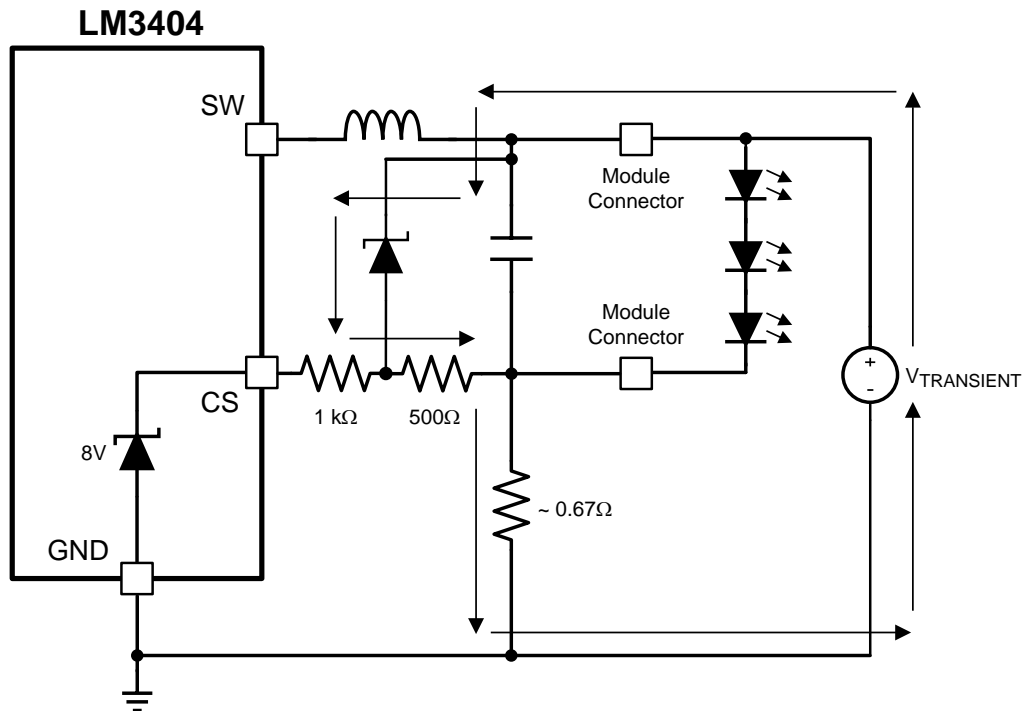

Figure 24. CS Pin With OVP, Transient Path With Protection

8.1.8.3 VIN Pin Protection

The VIN pin also has an ESD structure from the pin to GND with a breakdown voltage of approximately 80 V. Any transient that exceeds this voltage may damage the device. Although transient absorption is usually present at the front end of a switching converter circuit, damage to the VIN pin can still occur.

When V_{IN} is hot swapped in, the current that rushes in to charge C_{IN} up to the V_{IN} value also charges (energizes) the circuit board trace inductance as shown in Figure 25. The excited trace inductance then resonates with the input capacitance (similar to an under-damped LC tank circuit) and causes voltages at the VIN pin to rise well in excess of both V_{IN} and the voltage at the module input connector as clamped by the input TVS. If the resonating voltage at the VIN pin exceeds the 80-V breakdown voltage of the ESD structure, the ESD structure will activate and then snap-back to a lower voltage due to its inherent design. If this lower snap-back voltage is less than the applied nominal V_{IN} voltage, then significant current will flow through the ESD structure resulting in the IC being damaged.

An additional TVS or small Zener diode must be placed as close as possible to the VIN pins of each IC on the board, in parallel with the input capacitor as shown in Figure 26. A minor amount of series resistance in the input line would also help, but would lower overall conversion efficiency. For this reason, NTC resistors are often used as inrush limiters instead.

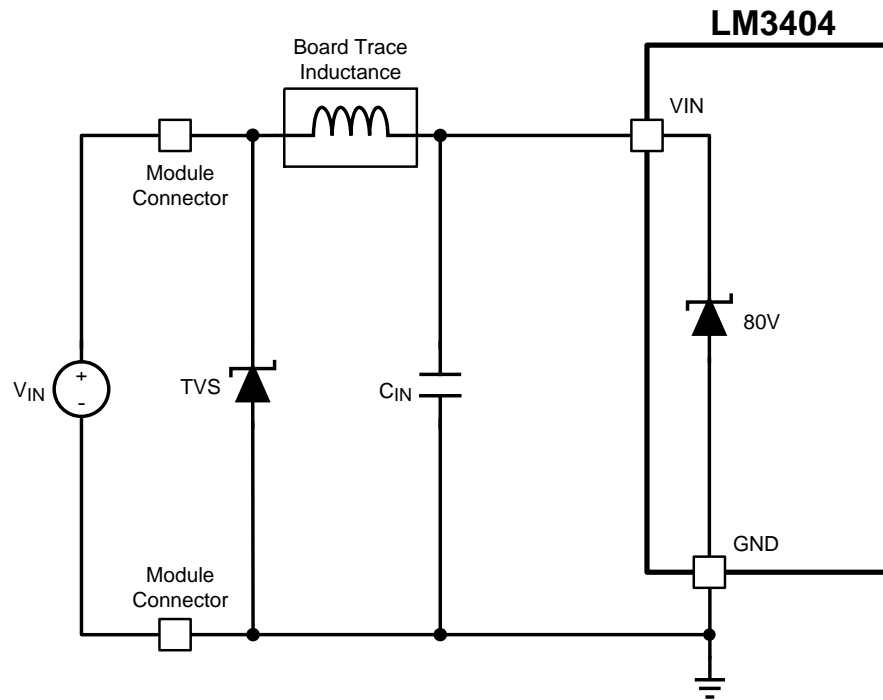

Figure 25. VIN Pin With Typical Input Protection

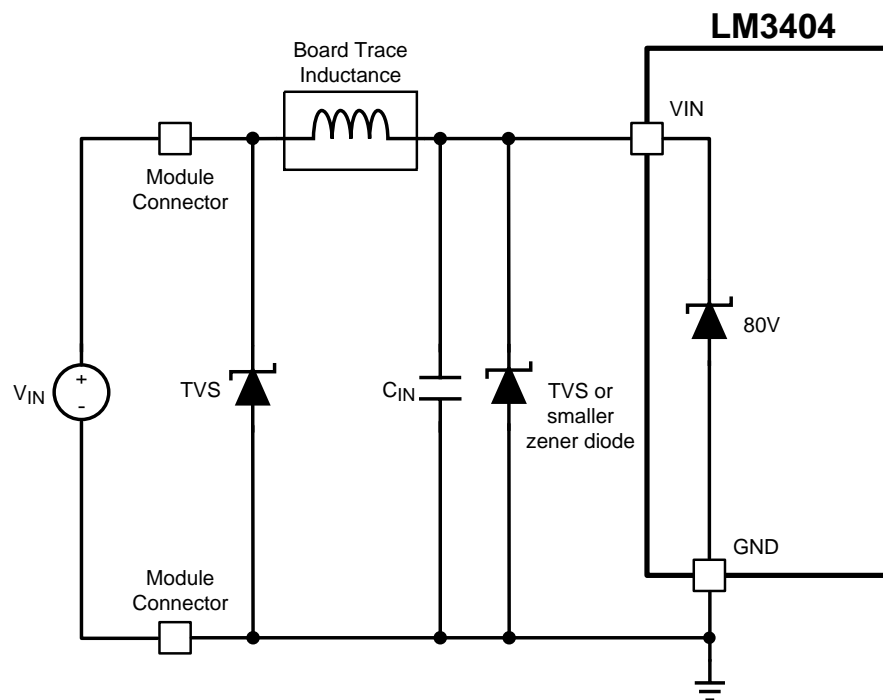

Figure 26. VIN Pin With Additional Input Protection

8.1.8.4 General Comments Regarding Other Pins

Any pin that goes off-board through a connector must have series resistance of at least 1 kΩ to 10 kΩ in series with it to protect it from ESD or other transients. These series resistors limit the peak current that can flow (or cause a voltage drop) during a transient event, thus protecting the pin and the device. Pins that are not used must **not** be left floating. Instead, the pins must be tied to GND or to an appropriate voltage through resistance.

8.2 Typical Applications

8.2.1 Design Example 1: LM3404

The first example circuit will guide the user through component selection for an architectural accent lighting application. A regulated DC voltage input of 24 V ±10% will power a 5.4-W warm white LED module that consists of four LEDs in a 2 × 2 series-parallel configuration. The module will be treated as a two-terminal element and driven with a forward current of 700 mA ±5%. The typical forward voltage of the LED module in thermal steady state is 6.9 V, hence the average output voltage will be 7.1 V. The objective of this application is to place the complete current regulator and LED module in a compact space formerly occupied by a halogen light source. (The LED will be on a separate metal-core PCB and heatsink.) Switching frequency will be 400 kHz to keep switching loss low, as the confined space with no air-flow requires a maximum temperature rise of 50°C in each circuit component. A small solution size is also important, as the regulator must fit on a circular PCB with a 1.5" diameter. A complete bill of materials can be found in [Table 2](#) at the end of this example.

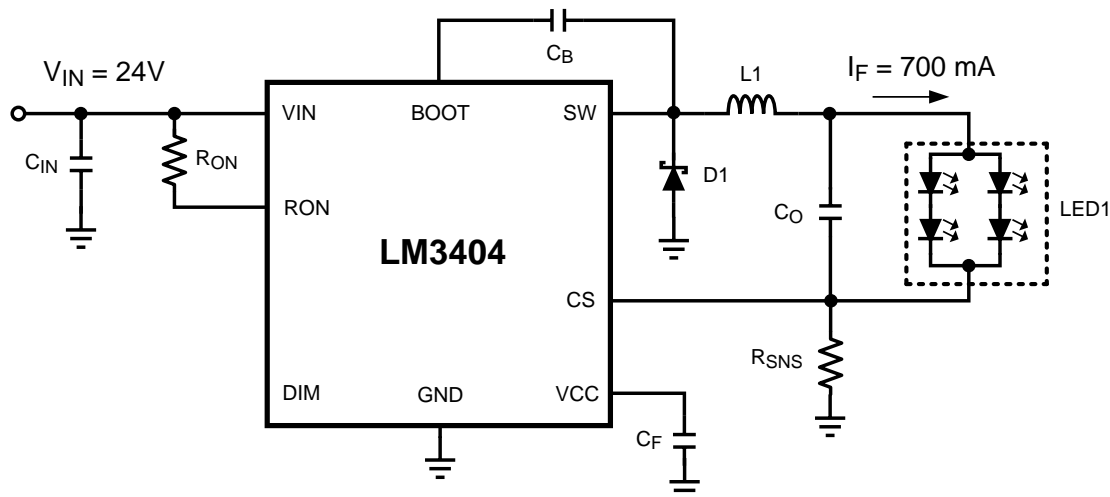

Figure 27. Schematic for Design Example 1

8.2.1.1 Design Requirements

- Input voltage: 24 V ±10%
- LED forward voltage: 6.9 V
- LED current: 700 mA
- Switching frequency: 400 kHz

8.2.1.2 Detailed Design Procedure

8.2.1.2.1 RON and tON

A moderate switching frequency is needed in this application to balance the requirements of magnetics size and efficiency. RON is selected from the equation for switching frequency as shown in [Equation 17](#) and [Equation 18](#).

$$R_{ON} = \frac{V_O}{1.34 \times 10^{-10} \times f_{SW}} \quad (17)$$

$$R_{ON} = 7.1 / (1.34 \times 10^{-10} \times 4 \times 10^5) = 132.5 \text{ k}\Omega \quad (18)$$

Typical Applications (continued)

The closest 1% tolerance resistor is 133 k Ω . The switching frequency and on-time of the circuit can then be found using the equations relating R_{ON} and t_{ON} to f_{SW} , as shown in [Equation 19](#) and [Equation 20](#)

$$f_{SW} = 7.1 / (1.33 \times 10^5 \times 1.34 \times 10^{-10}) = 398 \text{ kHz} \quad (19)$$

$$t_{ON} = (1.34 \times 10^{-10} \times 1.33 \times 10^5) / 24 = 743 \text{ ns} \quad (20)$$

8.2.1.2.2 Output Inductor

Because an output capacitor will be used to filter some of the AC ripple current, the inductor ripple current can be set higher than the LED ripple current. A value of 40% $_{P-P}$ is typical in many buck converters:

$$\Delta i_L = 0.4 \times 0.7 = 0.28 \text{ A} \quad (21)$$

With the target ripple current determined the inductance can be chosen:

$$L_{MIN} = \frac{V_{IN} - V_O}{\Delta i_L} \times t_{ON} \quad (22)$$

$$L_{MIN} = [(24 - 7.1) \times 7.43 \times 10^{-7}] / (0.28) = 44.8 \text{ } \mu\text{H} \quad (23)$$

The closest standard inductor value is 47 μH . The average current rating must be greater than 700 mA to prevent overheating in the inductor. Separation between the LM3404 drivers and the LED arrays means that heat from the inductor will not threaten the lifetime of the LEDs, but an overheated inductor could still cause the LM3404 to enter thermal shutdown.

The inductance of the standard part chosen is $\pm 20\%$. With this tolerance the typical, minimum, and maximum inductor current ripples can be calculated:

$$\Delta i_{L(TYP)} = [(24 - 7.1) \times 7.43 \times 10^{-7}] / 47 \times 10^{-6} = 266 \text{ mA}_{P-P} \quad (24)$$

$$\Delta i_{L(MIN)} = [(24 - 7.1) \times 7.43 \times 10^{-7}] / 56 \times 10^{-6} = 223 \text{ mA}_{P-P} \quad (25)$$

$$\Delta i_{L(MAX)} = [(24 - 7.1) \times 7.43 \times 10^{-7}] / 38 \times 10^{-6} = 330 \text{ mA}_{P-P} \quad (26)$$

The peak LED/inductor current is then estimated:

$$I_{L(PEAK)} = I_L + 0.5 \times \Delta i_{L(MAX)} \quad (27)$$

$$I_{L(PEAK)} = 0.7 + 0.5 \times 0.330 = 866 \text{ mA} \quad (28)$$

In the case of a short circuit across the LED array, the LM3404 will continue to deliver rated current through the short but will reduce the output voltage to equal the CS pin voltage of 200 mV. The inductor ripple current and peak current in this condition would be equal to:

$$\Delta i_{L(LED-SHORT)} = [(24 - 0.2) \times 7.43 \times 10^{-7}] / 38 \times 10^{-6} = 465 \text{ mA}_{P-P} \quad (29)$$

$$I_{L(PEAK)} = 0.7 + 0.5 \times 0.465 = 933 \text{ mA} \quad (30)$$

In the case of a short at the switch node, the output, or from the CS pin to ground the short circuit current limit will engage at a typical peak current of 1.5 A. To prevent inductor saturation during these fault conditions the inductor's peak current rating must be above 1.5 A. A 47- μH off-the shelf inductor rated to 1.4 A (peak) and 1.5 A (average) with a DCR of 0.1 Ω will be used.

8.2.1.2.3 Using an Output Capacitor

This application does not require high frequency PWM dimming, allowing the use of an output capacitor to reduce the size and cost of the output inductor. To select the proper output capacitor, the equation from [Buck Converters With Output Capacitors](#) is re-arranged to yield [Equation 31](#).

$$Z_C = \frac{\Delta i_F}{\Delta i_L - \Delta i_F} \times r_D \quad (31)$$

The target tolerance for LED ripple current is 100 mA $_{P-P}$, and a typical value for r_D is 1.8 Ω at 700 mA. The required capacitor impedance to reduce the worst-case inductor ripple current of 333 mA $_{P-P}$ is therefore:

$$Z_C = [0.1 / (0.333 - 0.1)] \times 1.8 = 0.77 \Omega \quad (32)$$

A ceramic capacitor will be used and the required capacitance is selected based on the impedance at 400 kHz:

$$C_O = 1 / (2 \times \pi \times 0.77 \times 4 \times 10^5) = 0.51 \text{ } \mu\text{F} \quad (33)$$

Typical Applications (continued)

This calculation assumes that impedance due to the equivalent series resistance (ESR) and equivalent series inductance (ESL) of C_O is negligible. The closest 10% tolerance capacitor value is 1 μF . The capacitor used must be rated to 25 V or more and have an X7R dielectric. Several manufacturers produce ceramic capacitors with these specifications in the 0805 case size. A typical value for ESR is 3 m Ω .

8.2.1.2.4 R_{SNS}

A preliminary value for R_{SNS} was determined in selecting Δi_L . This value must be re-evaluated based on the calculations for Δi_F :

$$R_{\text{SNS}} = \frac{0.2 \times L}{I_F \times L + V_O \times t_{\text{SNS}} - \frac{V_{\text{IN}} - V_O}{2} \times t_{\text{ON}}} \quad (34)$$

$$t_{\text{SNS}} = 220 \text{ ns}, R_{\text{SNS}} = 0.33 \Omega \quad (35)$$

Sub-1- Ω resistors are available in both 1% and 5% tolerance. A 1%, 0.33- Ω device is the closest value, and a 0.33 W, 1206 size device will handle the power dissipation of 162 mW. With the resistance selected, the average value of LED current is re-calculated to ensure that current is within the $\pm 5\%$ tolerance requirement. The average LED current can be found using [Equation 36](#).

$$I_F = 0.2 / 0.33 - (7.1 \times 2.2 \times 10^{-7}) / 47 \times 10^{-6} + 0.266 / 2 \quad (36)$$

$$= 706 \text{ mA}, 1\% \text{ above } 700 \text{ mA} \quad (37)$$

8.2.1.2.5 Input Capacitor

Following the calculations from the Input Capacitor section, $\Delta v_{\text{IN(MAX)}}$ will be $24 \text{ V} \times 2\%_{\text{P-P}} = 480 \text{ mV}$. The minimum required capacitance is:

$$C_{\text{IN(MIN)}} = (0.7 \times 7.4 \times 10^{-7}) / 0.48 = 1.1 \mu\text{F} \quad (38)$$

To provide additional safety margin the a higher value of 3.3- μF ceramic capacitor rated to 50 V with X7R dielectric in an 1210 case size will be used. From [Application Information](#), input rms current is:

$$I_{\text{IN-RMS}} = 0.7 \times \text{Sqrt}(0.28 \times 0.72) = 314 \text{ mA} \quad (39)$$

Ripple current ratings for 1210 size ceramic capacitors are typically higher than 2 A, more than enough for this design.

8.2.1.2.6 Recirculating Diode

The input voltage of 24 V $\pm 5\%$ requires Schottky diodes with a reverse voltage rating greater than 30 V. The next highest standard voltage rating is 40 V. Selecting a 40-V rated diode provides a large safety margin for the ringing of the switch node and also makes cross-referencing of diodes from different vendors easier.

The next parameters to be determined are the forward current rating and case size. In this example the low duty cycle ($D = 7.1 / 24 = 28\%$) places a greater thermal stress on D1 than on the internal power MOSFET of the LM3404. The estimated average diode current is:

$$I_D = 0.706 \times 0.72 = 509 \text{ mA} \quad (40)$$

A Schottky with a forward current rating of 1 A would be adequate, however reducing the power dissipation is critical in this example. Higher current diodes have lower forward voltages, hence a 2-A rated diode will be used. To determine the proper case size, the dissipation and temperature rise in D1 can be calculated as shown in [Application Information](#). V_D for a case size such as SMB in a 40 V, 2-A Schottky diode at 700 mA is approximately 0.3 V and the θ_{JA} is 75°C/W. Power dissipation and temperature rise can be calculated as:

$$P_D = 0.509 \times 0.3 = 153 \text{ mW} \quad (41)$$

$$T_{\text{RISE}} = 0.153 \times 75 = 11.5^\circ\text{C} \quad (42)$$

8.2.1.2.7 C_B and C_F

The bootstrap capacitor C_B must always be a 10-nF ceramic capacitor with X7R dielectric. A 25-V rating is appropriate for all application circuits. The linear regulator filter capacitor C_F must always be a 100-nF ceramic capacitor, also with X7R dielectric and a 25-V rating.

Typical Applications (continued)

8.2.1.2.8 Efficiency

To estimate the electrical efficiency of this example the power dissipation in each current carrying element can be calculated and summed. Electrical efficiency, η , must not be confused with the optical efficacy of the circuit, which depends upon the LEDs themselves.

Total output power, P_O , is calculated as:

$$P_O = I_F \times V_O = 0.706 \times 7.1 = 5 \text{ W} \quad (43)$$

Conduction loss, P_C , in the internal MOSFET:

$$P_C = (I_F^2 \times R_{DS(ON)}) \times D = (0.706^2 \times 0.8) \times 0.28 = 112 \text{ mW} \quad (44)$$

Gate charging and VCC loss, P_G , in the gate drive and linear regulator:

$$P_G = (I_{IN-OP} + f_{SW} \times Q_G) \times V_{IN} \quad P_G = (600 \times 10^{-6} + 4 \times 10^5 \times 6 \times 10^{-9}) \times 24 = 72 \text{ mW} \quad (45)$$

Switching loss, P_S , in the internal MOSFET:

$$P_S = 0.5 \times V_{IN} \times I_F \times (t_r + t_f) \times f_{SW} \quad P_S = 0.5 \times 24 \times 0.706 \times 40 \times 10^{-9} \times 4 \times 10^5 = 136 \text{ mW} \quad (46)$$

AC rms current loss, P_{CIN} , in the input capacitor:

$$P_{CIN} = I_{IN(rms)}^2 \times ESR = 0.317^2 \times 0.003 = 0.3 \text{ mW (negligible)} \quad (47)$$

DCR loss, P_L , in the inductor

$$P_L = I_F^2 \times DCR = 0.706^2 \times 0.1 = 50 \text{ mW} \quad (48)$$

Recirculating diode loss, $P_D = 153 \text{ mW}$

Current Sense Resistor Loss, $P_{SNS} = 164 \text{ mW}$

Electrical efficiency, $\eta = P_O / (P_O + \text{Sum of all loss terms}) = 5 / (5 + 0.687) = 88\%$

Temperature Rise in the LM3404 IC is calculated as:

$$T_{LM3404} = (P_C + P_G + P_S) \times \theta_{JA} = (0.112 + 0.072 + 0.136) \times 155 = 49.2^\circ\text{C} \quad (49)$$

8.2.1.3 Application Curves

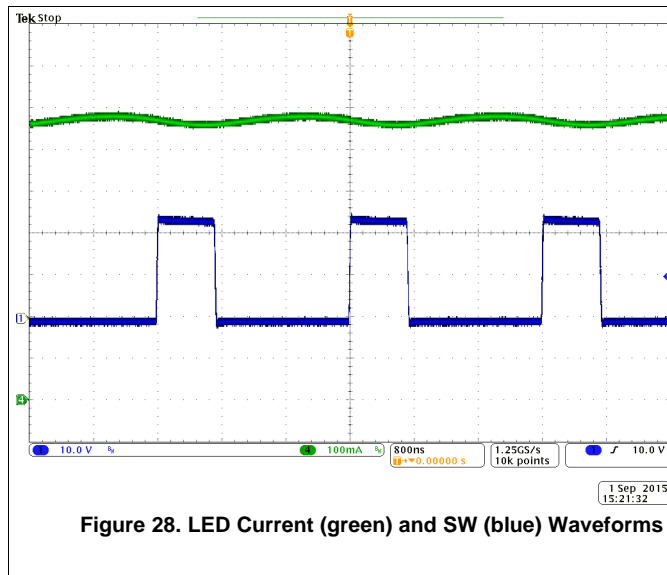

Figure 28. LED Current (green) and SW (blue) Waveforms

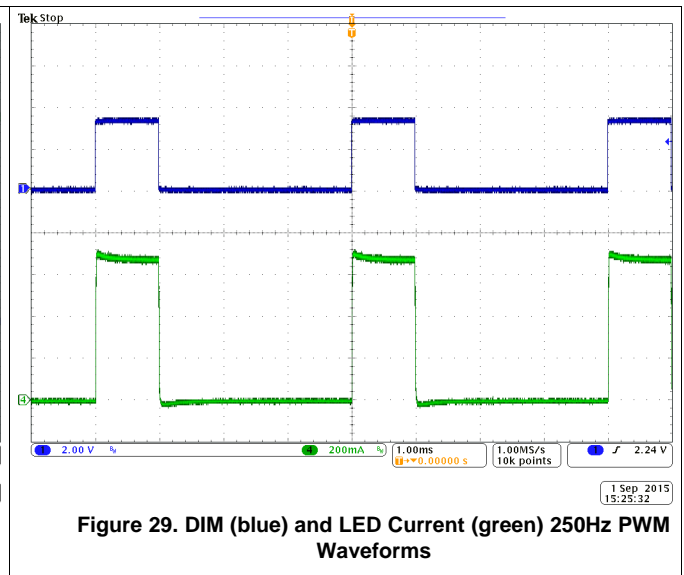

Figure 29. DIM (blue) and LED Current (green) 250Hz PWM Waveforms

Table 2. BOM for Design Example 1

ID	PART NUMBER	TYPE	SIZE	PARAMETER	QTY	VENDOR
U1	LM3404	LED Driver	SOIC-8	42 V, 1.2 A	1	TI
L1	SLF10145T-470M1R4	Inductor	10 × 10 × 4.5 mm	47 μH, 1.4 A, 120 mΩ	1	TDK

Typical Applications (continued)

Table 2. BOM for Design Example 1 (continued)

ID	PART NUMBER	TYPE	SIZE	PARAMETER	QTY	VENDOR
D1	CMSH2-40	Schottky Diode	SMB	40 V, 2 A	1	Central Semi
Cf	VJ0805Y104KXXAT	Capacitor	0805	100 nF 10%	1	Vishay
Cb	VJ0805Y103KXXAT	Capacitor	0805	10 nF 10%	1	Vishay
Cin	C3225X7R1H335M	Capacitor	1210	3.3 μF, 50V	1	TDK
Co	C2012X7R1E105M	Capacitor	0805	1 μF, 25V	1	TDK
Rsns	ERJ8BQFR33V	Resistor	1206	0.33 Ω 1%	1	Panasonic
Ron	CRCW08051333F	Resistor	0805	133 kΩ 1%	1	Vishay

8.2.2 Design Example 2: LM3404HV

The second example circuit will guide the user through component selection for an outdoor general lighting application. A regulated DC voltage input of 48 V ±10% will power ten series-connected LEDs at 500 mA ±10% with a ripple current of 50 mA_{P-P} or less. The typical forward voltage of the LED module in thermal steady state is 35 V, hence the average output voltage will be 35.2 V. A complete bill of materials can be found in Table 3.

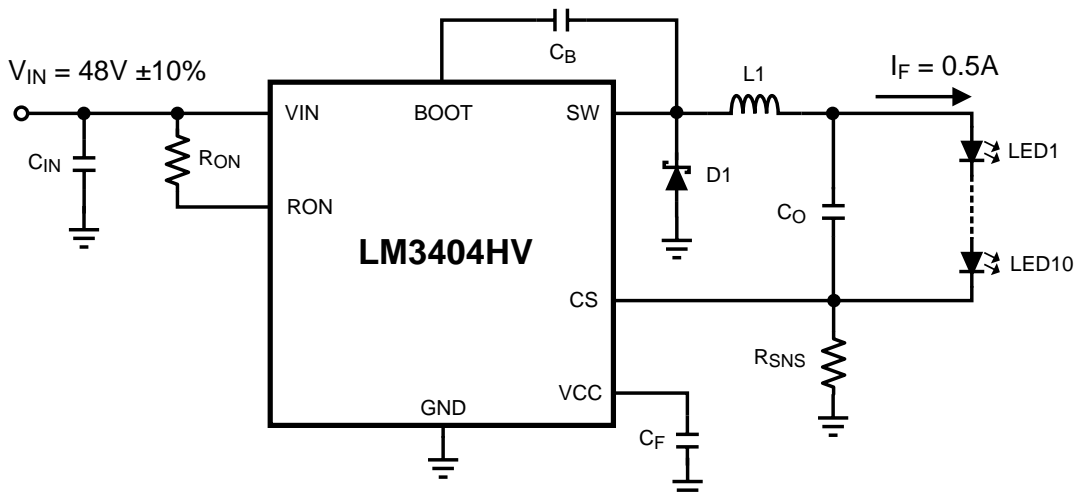

Figure 30. Schematic for Design Example 2

8.2.2.1 Design Requirements

- Input voltage: 48 V ±10%
- LED forward voltage: 35 V
- LED current: 500 mA
- Switching frequency: 225 kHz

8.2.2.2 Detailed Design Procedure

8.2.2.2.1 RON and tON

A low switching frequency, 225 kHz, is needed in this application, as high-efficiency and low-power dissipation take precedence over the solution size. RON is selected from the equation for switching frequency as shown in Equation 50 and Equation 51.

$$R_{ON} = \frac{V_O}{1.34 \times 10^{-10} \times f_{SW}} \tag{50}$$

$$R_{ON} = 35.2 / (1.34 \times 10^{-10} \times 2.25 \times 10^5) = 1.16 \text{ M}\Omega \tag{51}$$

The next highest 1% tolerance resistor is 1.18 MΩ. The switching frequency and on-time of the circuit can then be found using the equations relating R_{ON} and t_{ON} to f_{SW} , as shown in [Equation 52](#) and [Equation 53](#).

$$f_{SW} = 35.2 / (1.18 \times 10^6 \times 1.34 \times 10^{-10}) = 223 \text{ kHz} \quad (52)$$

$$t_{ON} = (1.34 \times 10^{-10} \times 1.18 \times 10^6) / 48 = 3.3 \mu\text{s} \quad (53)$$

8.2.2.2.2 Output Inductor

Because an output capacitor will be used to filter some of the AC ripple current, the inductor ripple current can be set higher than the LED ripple current. A value of 30%_{P,P} makes a good trade-off between the current ripple and the size of the inductor:

$$\Delta i_L = 0.3 \times 0.5 = 0.15\text{A} \quad (54)$$

With the target ripple current determined the inductance can be chosen:

$$L_{MIN} = \frac{V_{IN} - V_O}{\Delta i_L} \times t_{ON} \quad (55)$$

$$L_{MIN} = [(48 - 35.2) \times 3.3 \times 10^{-6}] / (0.15) = 281 \mu\text{H} \quad (56)$$

The closest standard inductor value above 281 is 330 μH. The average current rating must be greater than 0.5 A to prevent overheating in the inductor. In this example the LM3404HV driver and the LED array share the same metal-core PCB, meaning that heat from the inductor could threaten the lifetime of the LEDs. For this reason the average current rating of the inductor used must have a derating of about 50%, or 1 A.

The inductance of the standard part chosen is ±20%. With this tolerance the typical, minimum, and maximum inductor current ripples can be calculated:

$$\Delta i_{L(TYP)} = [(48 - 35.2) \times 3.3 \times 10^{-6}] / 330 \times 10^{-6} = 128 \text{ mA}_{P,P} \quad (57)$$

$$\Delta i_{L(MIN)} = [(48 - 35.2) \times 3.3 \times 10^{-6}] / 396 \times 10^{-6} = 107 \text{ mA}_{P,P} \quad (58)$$

$$\Delta i_{L(MAX)} = [(48 - 35.2) \times 3.3 \times 10^{-6}] / 264 \times 10^{-6} = 160 \text{ mA}_{P,P} \quad (59)$$

The peak inductor current is then estimated:

$$I_{L(PEAK)} = I_L + 0.5 \times \Delta i_{L(MAX)} \quad (60)$$

$$I_{L(PEAK)} = 0.5 + 0.5 \times 0.16 = 0.58\text{A} \quad (61)$$

In the case of a short circuit across the LED array, the LM3404HV will continue to deliver rated current through the short but will reduce the output voltage to equal the CS pin voltage of 200 mV. The inductor ripple current and peak current in this condition would be equal to:

$$\Delta i_{L(LED-SHORT)} = [(48 - 0.2) \times 3.3 \times 10^{-6}] / 264 \times 10^{-6} = 0.598\text{A}_{P,P} \quad (62)$$

$$I_{L(PEAK)} = 0.5 + 0.5 \times 0.598 = 0.8 \text{ A} \quad (63)$$

In the case of a short at the switch node, the output, or from the CS pin to ground the short circuit current limit will engage at a typical peak current of 1.5 A. To prevent inductor saturation during these fault conditions the inductor's peak current rating must be above 1.5 A. A 330-μH off-the shelf inductor rated to 1.9 A (peak) and 1 A (average) with a DCR of 0.56 Ω will be used.

8.2.2.2.3 Using an Output Capacitor

This application uses sub-1 kHz frequency PWM dimming, allowing the use of a small output capacitor to reduce the size and cost of the output inductor. To select the proper output capacitor, the equation from buck regulators with output capacitors is re-arranged to yield [Equation 64](#).

$$Z_C = \frac{\Delta i_F}{\Delta i_L - \Delta i_F} \times r_D \quad (64)$$

The target tolerance for LED ripple current is 50 mA_{P,P}, and the typical value for r_D is 10 Ω with ten LEDs in series. The required capacitor impedance to reduce the worst-case steady-state inductor ripple current of 160 mA_{P,P} is therefore:

$$Z_C = [0.05 / (0.16 - 0.05)] \times 10 = 4.5 \Omega \quad (65)$$

A ceramic capacitor will be used and the required capacitance is selected based on the impedance at 223 kHz:

$$C_O = 1 / (2 \times \pi \times 4.5 \times 2.23 \times 10^5) = 0.16 \mu\text{F} \quad (66)$$

This calculation assumes that impedance due to the equivalent series resistance (ESR) and equivalent series inductance (ESL) of C_O is negligible. The closest 10% tolerance capacitor value is 0.15 μF . The capacitor used must be rated to 50 V or more and have an X7R dielectric. Several manufacturers produce ceramic capacitors with these specifications in the 0805 case size. ESR values are not typically provided for such low value capacitors, however it can be assumed to be under 100 m Ω , leaving plenty of margin to meet to LED ripple current requirement. The low capacitance required allows the use of a 100-V rated, 1206-size capacitor. The rating of 100 V ensures that the capacitance will not decrease significantly when the DC output voltage is applied across the capacitor.

8.2.2.2.4 R_{SNS}

A preliminary value for R_{SNS} was determined in selecting Δi_L . This value must be re-evaluated based on the calculations for Δi_F :

$$R_{\text{SNS}} = \frac{0.2 \times L}{I_F \times L + V_O \times t_{\text{SNS}} - \frac{V_{\text{IN}} - V_O}{2} \times t_{\text{ON}}} \quad (67)$$

$$t_{\text{SNS}} = 220 \text{ ns}, R_{\text{SNS}} = 0.43 \Omega \quad (68)$$

Sub-1- Ω resistors are available in both 1% and 5% tolerance. A 1%, 0.43- Ω device is the closest value, and a 0.25 W, 0805 size device will handle the power dissipation of 110 mW. With the resistance selected, the average value of LED current is re-calculated to ensure that current is within the $\pm 10\%$ tolerance requirement. The average LED current can be found using [Equation 69](#).

$$I_F = 0.2 / 0.33 - (7.1 \times 2.2 \times 10^{-7}) / 47 \times 10^{-6} + 0.266 / 2 = 505 \text{ mA} \quad (69)$$

8.2.2.2.5 Input Capacitor

Following the calculations from the Input Capacitor section, $\Delta v_{\text{IN(MAX)}}$ will be 48 V \times 2%_{P-P} = 960 mV. The minimum required capacitance is:

$$C_{\text{IN(MIN)}} = (0.5 \times 3.3 \times 10^{-6}) / 0.96 = 1.7 \mu\text{F} \quad (70)$$

To provide additional safety margin a 2.2- μF ceramic capacitor rated to 100 V with X7R dielectric in an 1812 case size will be used. From [Application Information](#), input rms current is:

$$I_{\text{IN-RMS}} = 0.5 \times \text{Sqrt}(0.73 \times 0.27) = 222 \text{ mA} \quad (71)$$

Ripple current ratings for 1812 size ceramic capacitors are typically higher than 2 A, more than enough for this design, and the ESR is approximately 3 m Ω .

8.2.2.2.6 Recirculating Diode

The input voltage of 48 V requires Schottky diodes with a reverse voltage rating greater than 50 V. The next highest standard voltage rating is 60 V. Selecting a 60-V rated diode provides a large safety margin for the ringing of the switch node and also makes cross-referencing of diodes from different vendors easier.

The next parameters to be determined are the forward current rating and case size. In this example the high duty cycle ($D = 35.2 / 48 = 73\%$) places a greater thermal stress on the internal power MOSFET than on D1. The estimated average diode current is:

$$I_D = 0.5 \times 0.27 = 135 \text{ mA} \quad (72)$$

A Schottky with a forward current rating of 0.5 A would be adequate; however, reducing the power dissipation is critical in this example. Higher current diodes have lower forward voltages, hence a 1-A rated diode will be used. To determine the proper case size, the dissipation and temperature rise in D1 can be calculated as shown in [Application Information](#). V_D for a case size such as SMA in a 60-V, 1-A Schottky diode at 0.5 A is approximately 0.35 V and the θ_{JA} is 75°C/W. Power dissipation and temperature rise can be calculated as:

$$P_D = 0.135 \times 0.35 = 47 \text{ mW } T_{\text{RISE}} = 0.047 \times 75 = 3.5^\circ\text{C} \quad (73)$$

8.2.2.2.7 C_B and C_F

The bootstrap capacitor C_B must always be a 10-nF ceramic capacitor with X7R dielectric. A 25-V rating is appropriate for all application circuits. The linear regulator filter capacitor C_F must always be a 100-nF ceramic capacitor, also with X7R dielectric and a 25-V rating.

8.2.2.2.8 Efficiency

To estimate the electrical efficiency of this example the power dissipation in each current carrying element can be calculated and summed. Electrical efficiency, η, must not be confused with the optical efficacy of the circuit, which depends upon the LEDs themselves.

Total output power, P_O, is calculated as:

$$P_O = I_F \times V_O = 0.5 \times 35.2 = 17.6 \text{ W} \quad (74)$$

Conduction loss, P_C, in the internal MOSFET:

$$P_C = (I_F^2 \times R_{\text{DS(on)}}) \times D = (0.5^2 \times 0.8) \times 0.73 = 146 \text{ mW} \quad (75)$$

Gate charging and VCC loss, P_G, in the gate drive and linear regulator:

$$P_G = (I_{\text{IN-OP}} + f_{\text{SW}} \times Q_G) \times V_{\text{IN}} P_G = (600 \times 10^{-6} + 2.23 \times 10^5 \times 6 \times 10^{-9}) \times 48 = 94 \text{ mW} \quad (76)$$

Switching loss, P_S, in the internal MOSFET:

$$P_S = 0.5 \times V_{\text{IN}} \times I_F \times (t_r + t_f) \times f_{\text{SW}} P_S = 0.5 \times 48 \times 0.5 \times 40 \times 10^{-9} \times 2.23 \times 10^5 = 107 \text{ mW} \quad (77)$$

AC rms current loss, P_{CIN}, in the input capacitor:

$$P_{\text{CIN}} = I_{\text{IN(rms)}}^2 \times \text{ESR} = 0.222^2 \times 0.003 = 0.1 \text{ mW (negligible)} \quad (78)$$

DCR loss, P_L, in the inductor

$$P_L = I_F^2 \times \text{DCR} = 0.5^2 \times 0.56 = 140 \text{ mW} \quad (79)$$

Recirculating diode loss, P_D = 47 mW

Current Sense Resistor Loss, P_{SNS} = 110 mW

Electrical efficiency, η = P_O / (P_O + Sum of all loss terms) = 17.6 / (17.6 + 0.644) = 96%

Temperature Rise in the LM3404HV IC is calculated as:

$$T_{\text{LM3404}} = (P_C + P_G + P_S) \times \theta_{\text{JA}} = (0.146 + 0.094 + 0.107) \times 155 = 54^\circ\text{C} \quad (80)$$

8.2.2.3 Application Curves

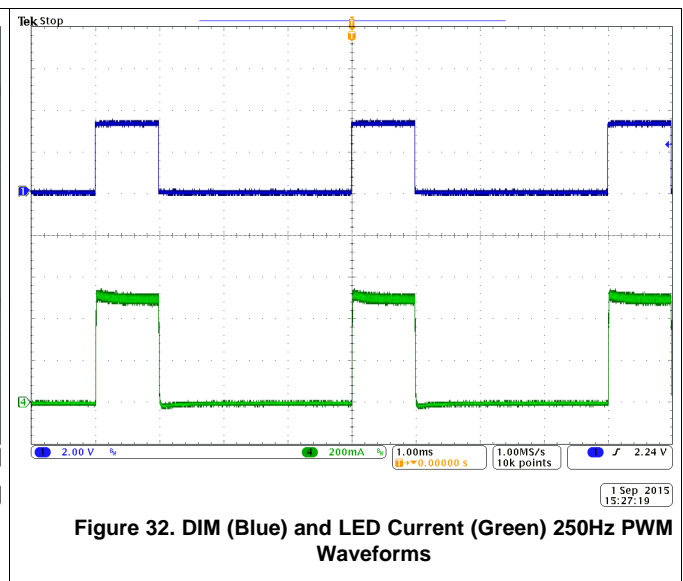
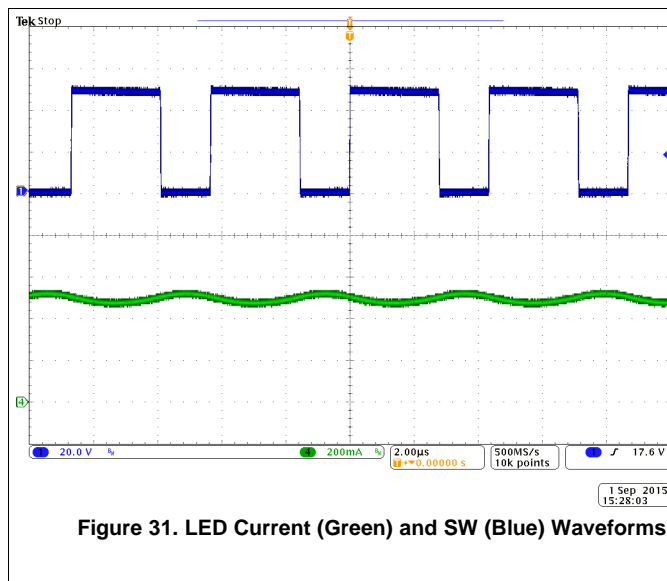

Table 3. BOM for Design Example 2

ID	PART NUMBER	TYPE	SIZE	PARAMETERS	QTY	VENDOR
U1	LM3404HV	LED Driver	SOIC-8	75 V, 1.2 A	1	TI
L1	DO5022P-334	Inductor	18.5 × 15.4 × 7.1 mm	330 μH, 1.9 A, 0.56 Ω	1	Coilcraft
D1	CMSH1-60M	Schottky Diode	SMA	60 V, 1 A	1	Central Semi
Cf	VJ0805Y104KXXAT	Capacitor	0805	100 nF 10%	1	Vishay
Cb	VJ0805Y103KXXAT	Capacitor	0805	10 nF 10%	1	Vishay
Cin	C4532X7R2A225M	Capacitor	1812	2.2 μF, 100 V	1	TDK
Co	C3216X7R2A154M	Capacitor	1206	0.15 μF, 100 V	1	TDK
Rsns	ERJ6BQFR43V	Resistor	0805	0.43 Ω 1%	1	Panasonic
Ron	CRCW08051184F	Resistor	0805	1.18 MΩ 1%	1	Vishay

9 Power Supply Recommendations

Use any DC output power supply with a maximum voltage high enough for the application. The power supply must have a minimum current limit of at least 1 A.

10 Layout

10.1 Layout Guidelines

The performance of any switching converter depends as much upon the layout of the PCB as the component selection. The following guidelines will help the user design a circuit with maximum rejection of outside EMI and minimum generation of unwanted EMI.

10.1.1 Compact Layout

Parasitic inductance can be reduced by keeping the power path components close together and keeping the area of the loops that high currents travel small. Short, thick traces or copper pours (shapes) are best. In particular, the switch node (where L1, D1, and the SW pin connect) must be just large enough to connect all three components without excessive heating from the current it carries. The LM3404 and LM3404HV devices operate in two distinct cycles whose high current paths are shown in [Figure 33](#):

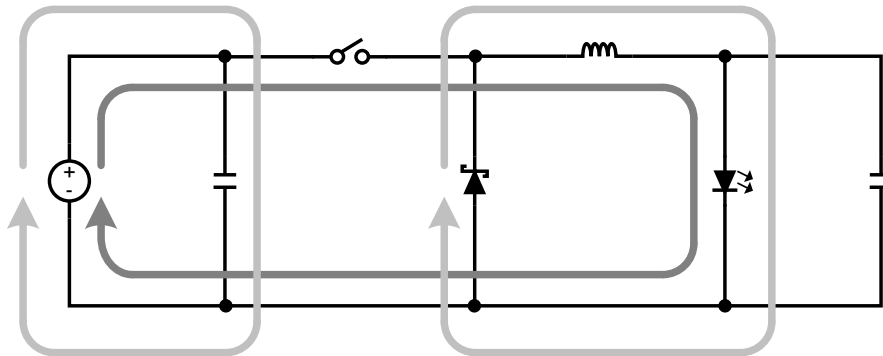

Figure 33. Buck Converter Current Loops

The dark grey, inner loop represents the high current path during the MOSFET on-time. The light grey, outer loop represents the high current path during the off-time.

10.1.2 Ground Plane and Shape Routing

The diagram of [Figure 33](#) is also useful for analyzing the flow of continuous current versus the flow of pulsating currents. The circuit paths with current flow during both the on-time and off-time are considered to be continuous current, while those that carry current during the on-time or off-time only are pulsating currents. Preference in routing must be given to the pulsating current paths, as these are the portions of the circuit most likely to emit EMI. The ground plane of a PCB is a conductor and return path, and it is susceptible to noise injection just as any other circuit path. The continuous current paths on the ground net can be routed on the system ground plane with less risk of injecting noise into other circuits. The path between the input source and the input capacitor and the path between the recirculating diode and the LEDs and current sense resistor are examples of continuous current paths. In contrast, the path between the recirculating diode and the input capacitor carries a large pulsating current. This path must be routed with a short, thick shape, preferably on the component side of the PCB. Multiple vias in parallel must be used right at the pad of the input capacitor to connect the component side shapes to the ground plane. A second pulsating current loop that is often ignored is the gate drive loop formed by the SW and BOOT pins and capacitor C_B . To minimize this loop at the EMI it generates, keep C_B close to the SW and BOOT pins.

Layout Guidelines (continued)

10.1.3 Current Sensing

The CS pin is a high-impedance input, and the loop created by R_{SNS} , R_Z (if used), the CS pin and ground must be made as small as possible to maximize noise rejection. Therefore, R_{SNS} must be placed as close as possible to the CS and GND pins of the IC.

10.1.4 Remote LED Arrays

In some applications, the LED or LED array can be far away (several inches or more) from the LM3404 and LM3404HV devices, or on a separate PCB connected by a wiring harness. When an output capacitor is used and the LED array is large or separated from the rest of the converter, the output capacitor must be placed close to the LEDs to reduce the effects of parasitic inductance on the AC impedance of the capacitor. The current sense resistor must remain on the same PCB, close to the LM3404 and LM3404HV devices.

10.2 Layout Example

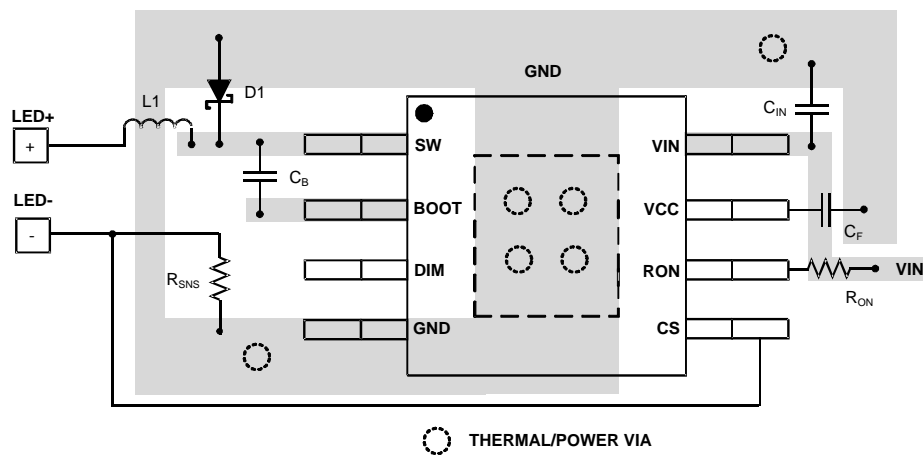

Figure 34. Layout Example

11 Device and Documentation Support

11.1 Device Support

11.1.1 Third-Party Products Disclaimer

TI'S PUBLICATION OF INFORMATION REGARDING THIRD-PARTY PRODUCTS OR SERVICES DOES NOT CONSTITUTE AN ENDORSEMENT REGARDING THE SUITABILITY OF SUCH PRODUCTS OR SERVICES OR A WARRANTY, REPRESENTATION OR ENDORSEMENT OF SUCH PRODUCTS OR SERVICES, EITHER ALONE OR IN COMBINATION WITH ANY TI PRODUCT OR SERVICE.

11.2 Related Links

The table below lists quick access links. Categories include technical documents, support and community resources, tools and software, and quick access to sample or buy.

Table 4. Related Links

PARTS	PRODUCT FOLDER	SAMPLE & BUY	TECHNICAL DOCUMENTS	TOOLS & SOFTWARE	SUPPORT & COMMUNITY
LM3404	Click here	Click here	Click here	Click here	Click here
LM3404HV	Click here	Click here	Click here	Click here	Click here

11.3 Community Resources

The following links connect to TI community resources. Linked contents are provided "AS IS" by the respective contributors. They do not constitute TI specifications and do not necessarily reflect TI's views; see TI's [Terms of Use](#).

TI E2E™ Online Community *TI's Engineer-to-Engineer (E2E) Community*. Created to foster collaboration among engineers. At e2e.ti.com, you can ask questions, share knowledge, explore ideas and help solve problems with fellow engineers.

Design Support *TI's Design Support* Quickly find helpful E2E forums along with design support tools and contact information for technical support.

11.4 Trademarks

PowerPAD, E2E are trademarks of Texas Instruments. All other trademarks are the property of their respective owners.

11.5 Electrostatic Discharge Caution



These devices have limited built-in ESD protection. The leads should be shorted together or the device placed in conductive foam during storage or handling to prevent electrostatic damage to the MOS gates.

11.6 Glossary

[SLYZ022](#) — *TI Glossary*.

This glossary lists and explains terms, acronyms, and definitions.

12 Mechanical, Packaging, and Orderable Information

The following pages include mechanical, packaging, and orderable information. This information is the most current data available for the designated devices. This data is subject to change without notice and revision of this document. For browser-based versions of this data sheet, refer to the left-hand navigation.

PACKAGING INFORMATION

Orderable Device	Status (1)	Package Type	Package Drawing	Pins	Package Qty	Eco Plan (2)	Lead/Ball Finish (6)	MSL Peak Temp (3)	Op Temp (°C)	Device Marking (4/5)	Samples
LM3404HVMA/NOPB	ACTIVE	SOIC	D	8	95	Green (RoHS & no Sb/Br)	CU SN	Level-1-260C-UNLIM	-40 to 125	L3404 HVMA	Samples
LM3404HVMAX/NOPB	ACTIVE	SOIC	D	8	2500	Green (RoHS & no Sb/Br)	CU SN	Level-1-260C-UNLIM	-40 to 125	L3404 HVMA	Samples
LM3404HVMR/NOPB	ACTIVE	SO PowerPAD	DDA	8	95	Green (RoHS & no Sb/Br)	CU SN	Level-3-260C-168 HR	-40 to 125	L3404 HVMR	Samples
LM3404HVMRX/NOPB	ACTIVE	SO PowerPAD	DDA	8	2500	Green (RoHS & no Sb/Br)	CU SN	Level-3-260C-168 HR	-40 to 125	L3404 HVMR	Samples
LM3404MA/NOPB	ACTIVE	SOIC	D	8	95	Green (RoHS & no Sb/Br)	CU SN	Level-1-260C-UNLIM	-40 to 125	L3404 MA	Samples
LM3404MAX/NOPB	ACTIVE	SOIC	D	8	2500	Green (RoHS & no Sb/Br)	CU SN	Level-1-260C-UNLIM	-40 to 125	L3404 MA	Samples
LM3404MR/NOPB	ACTIVE	SO PowerPAD	DDA	8	95	Green (RoHS & no Sb/Br)	CU SN	Level-3-260C-168 HR	-40 to 125	L3404 MR	Samples
LM3404MRX/NOPB	ACTIVE	SO PowerPAD	DDA	8	2500	Green (RoHS & no Sb/Br)	CU SN	Level-3-260C-168 HR	-40 to 125	L3404 MR	Samples

(1) The marketing status values are defined as follows:

ACTIVE: Product device recommended for new designs.

LIFEBUY: TI has announced that the device will be discontinued, and a lifetime-buy period is in effect.

NRND: Not recommended for new designs. Device is in production to support existing customers, but TI does not recommend using this part in a new design.

PREVIEW: Device has been announced but is not in production. Samples may or may not be available.

OBSOLETE: TI has discontinued the production of the device.

(2) Eco Plan - The planned eco-friendly classification: Pb-Free (RoHS), Pb-Free (RoHS Exempt), or Green (RoHS & no Sb/Br) - please check <http://www.ti.com/productcontent> for the latest availability information and additional product content details.

TBD: The Pb-Free/Green conversion plan has not been defined.

Pb-Free (RoHS): TI's terms "Lead-Free" or "Pb-Free" mean semiconductor products that are compatible with the current RoHS requirements for all 6 substances, including the requirement that lead not exceed 0.1% by weight in homogeneous materials. Where designed to be soldered at high temperatures, TI Pb-Free products are suitable for use in specified lead-free processes.

Pb-Free (RoHS Exempt): This component has a RoHS exemption for either 1) lead-based flip-chip solder bumps used between the die and package, or 2) lead-based die adhesive used between the die and leadframe. The component is otherwise considered Pb-Free (RoHS compatible) as defined above.

Green (RoHS & no Sb/Br): TI defines "Green" to mean Pb-Free (RoHS compatible), and free of Bromine (Br) and Antimony (Sb) based flame retardants (Br or Sb do not exceed 0.1% by weight in homogeneous material)

(3) MSL, Peak Temp. - The Moisture Sensitivity Level rating according to the JEDEC industry standard classifications, and peak solder temperature.

(4) There may be additional marking, which relates to the logo, the lot trace code information, or the environmental category on the device.

(5) Multiple Device Markings will be inside parentheses. Only one Device Marking contained in parentheses and separated by a "~" will appear on a device. If a line is indented then it is a continuation of the previous line and the two combined represent the entire Device Marking for that device.

(6) Lead/Ball Finish - Orderable Devices may have multiple material finish options. Finish options are separated by a vertical ruled line. Lead/Ball Finish values may wrap to two lines if the finish value exceeds the maximum column width.

Important Information and Disclaimer:The information provided on this page represents TI's knowledge and belief as of the date that it is provided. TI bases its knowledge and belief on information provided by third parties, and makes no representation or warranty as to the accuracy of such information. Efforts are underway to better integrate information from third parties. TI has taken and continues to take reasonable steps to provide representative and accurate information but may not have conducted destructive testing or chemical analysis on incoming materials and chemicals. TI and TI suppliers consider certain information to be proprietary, and thus CAS numbers and other limited information may not be available for release.

In no event shall TI's liability arising out of such information exceed the total purchase price of the TI part(s) at issue in this document sold by TI to Customer on an annual basis.

TAPE AND REEL INFORMATION

QUADRANT ASSIGNMENTS FOR PIN 1 ORIENTATION IN TAPE

*All dimensions are nominal

Device	Package Type	Package Drawing	Pins	SPQ	Reel Diameter (mm)	Reel Width W1 (mm)	A0 (mm)	B0 (mm)	K0 (mm)	P1 (mm)	W (mm)	Pin1 Quadrant
LM3404HVMAX/NOPB	SOIC	D	8	2500	330.0	12.4	6.5	5.4	2.0	8.0	12.0	Q1
LM3404HVMRX/NOPB	SO Power PAD	DDA	8	2500	330.0	12.4	6.5	5.4	2.0	8.0	12.0	Q1
LM3404MAX/NOPB	SOIC	D	8	2500	330.0	12.4	6.5	5.4	2.0	8.0	12.0	Q1
LM3404MRX/NOPB	SO Power PAD	DDA	8	2500	330.0	12.4	6.5	5.4	2.0	8.0	12.0	Q1

TAPE AND REEL BOX DIMENSIONS

*All dimensions are nominal

Device	Package Type	Package Drawing	Pins	SPQ	Length (mm)	Width (mm)	Height (mm)
LM3404HVMAX/NOPB	SOIC	D	8	2500	367.0	367.0	35.0
LM3404HVMRX/NOPB	SO PowerPAD	DDA	8	2500	367.0	367.0	35.0
LM3404MAX/NOPB	SOIC	D	8	2500	367.0	367.0	35.0
LM3404MRX/NOPB	SO PowerPAD	DDA	8	2500	367.0	367.0	35.0

DDA0008B

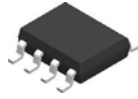

PACKAGE OUTLINE

PowerPAD™ SOIC - 1.7 mm max height

PLASTIC SMALL OUTLINE

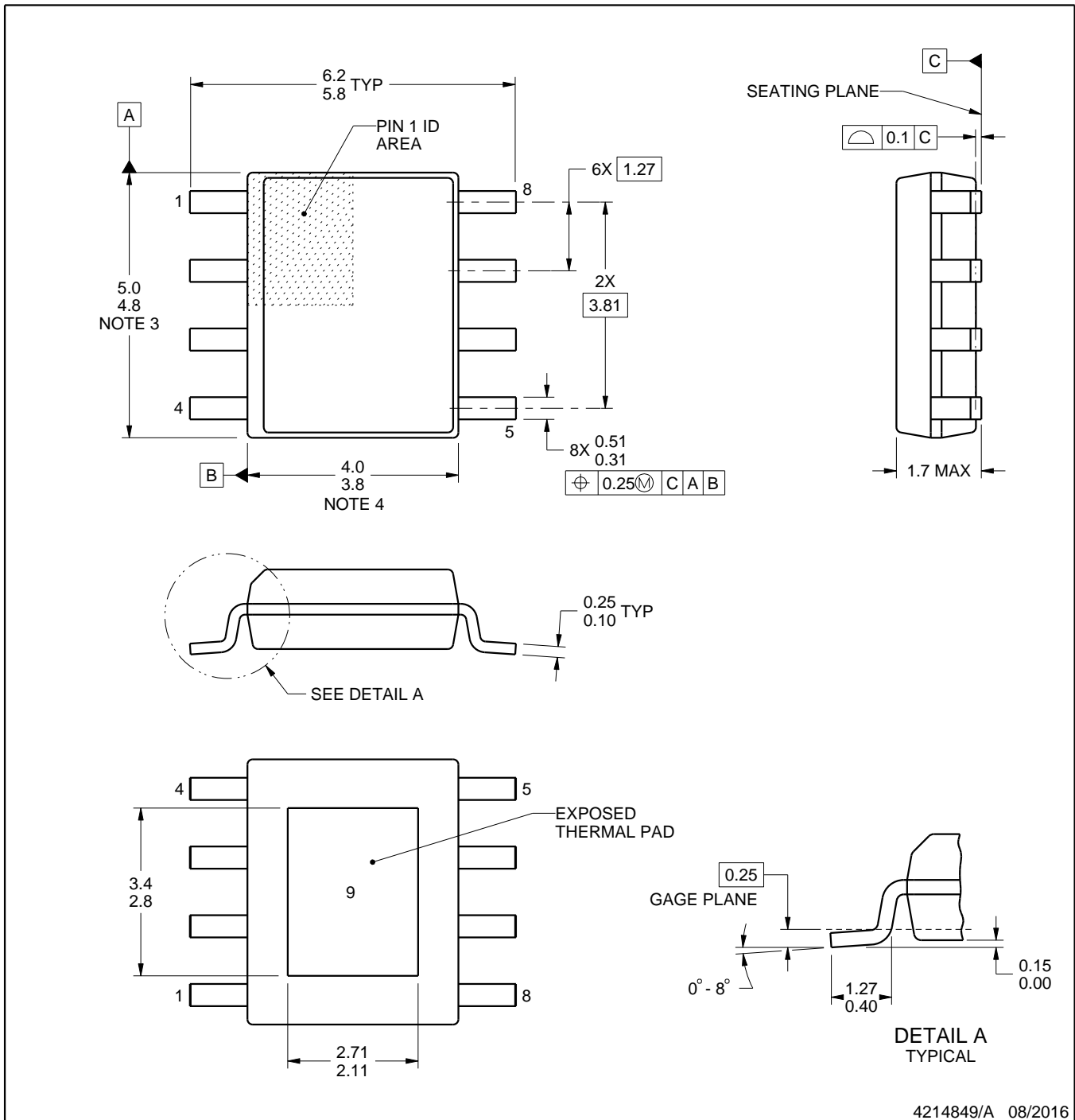

4214849/A 08/2016

NOTES:

PowerPAD is a trademark of Texas Instruments.

1. All linear dimensions are in millimeters. Any dimensions in parenthesis are for reference only. Dimensioning and tolerancing per ASME Y14.5M.
2. This drawing is subject to change without notice.
3. This dimension does not include mold flash, protrusions, or gate burrs. Mold flash, protrusions, or gate burrs shall not exceed 0.15 mm per side.
4. This dimension does not include interlead flash. Interlead flash shall not exceed 0.25 mm per side.
5. Reference JEDEC registration MS-012.

EXAMPLE BOARD LAYOUT

DDA0008B

PowerPAD™ SOIC - 1.7 mm max height

PLASTIC SMALL OUTLINE

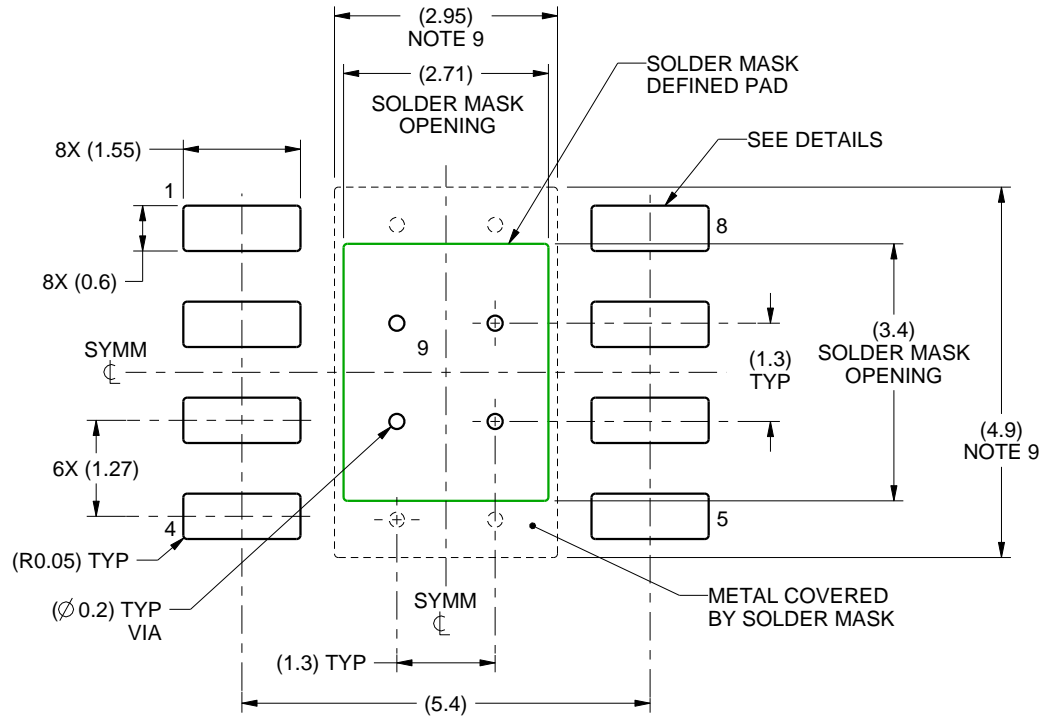

LAND PATTERN EXAMPLE
SCALE:10X

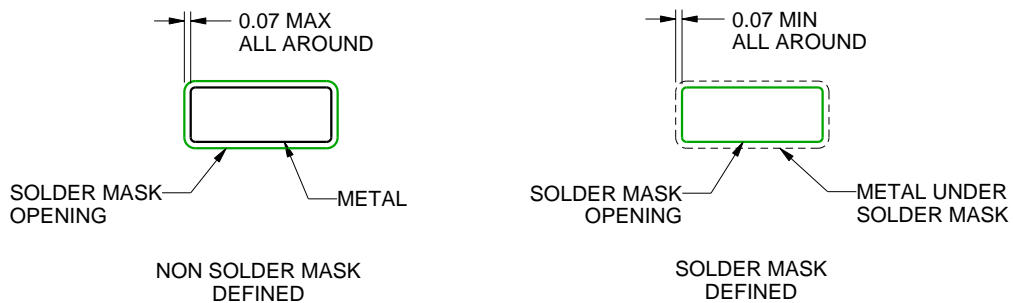

SOLDER MASK DETAILS
PADS 1-8

4214849/A 08/2016

NOTES: (continued)

6. Publication IPC-7351 may have alternate designs.
7. Solder mask tolerances between and around signal pads can vary based on board fabrication site.
8. This package is designed to be soldered to a thermal pad on the board. For more information, see Texas Instruments literature numbers SLMA002 (www.ti.com/lit/slma002) and SLMA004 (www.ti.com/lit/slma004).
9. Size of metal pad may vary due to creepage requirement.
10. Vias are optional depending on application, refer to device data sheet. If any vias are implemented, refer to their locations shown on this view. It is recommended that vias under paste be filled, plugged or tented.

EXAMPLE STENCIL DESIGN

DDA0008B

PowerPAD™ SOIC - 1.7 mm max height

PLASTIC SMALL OUTLINE

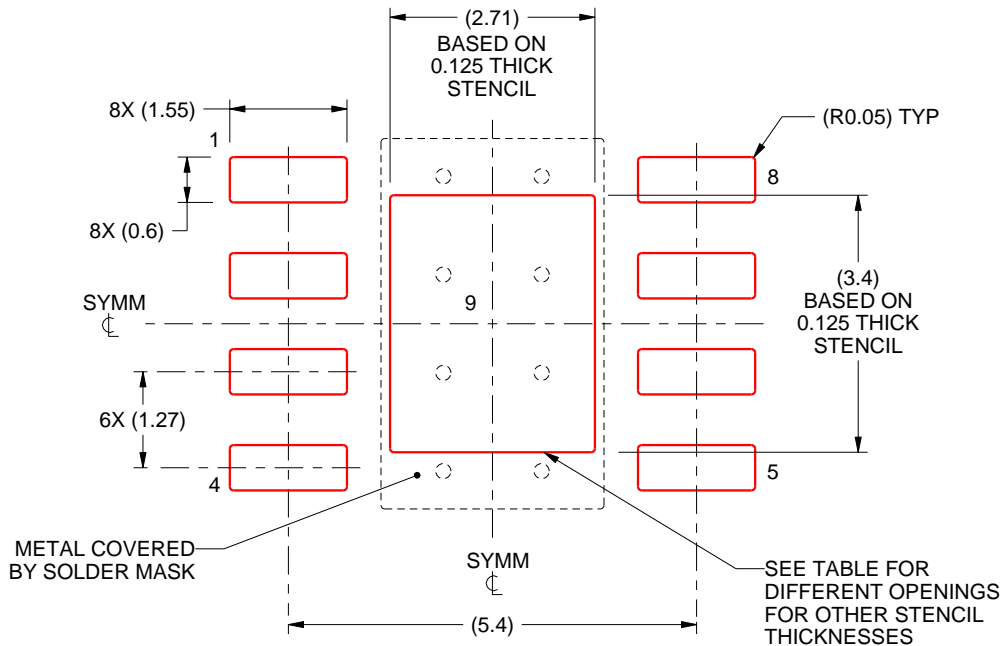

SOLDER PASTE EXAMPLE
 EXPOSED PAD
 100% PRINTED SOLDER COVERAGE BY AREA
 SCALE:10X

STENCIL THICKNESS	SOLDER STENCIL OPENING
0.1	3.03 X 3.80
0.125	2.71 X 3.40 (SHOWN)
0.150	2.47 X 3.10
0.175	2.29 X 2.87

4214849/A 08/2016

NOTES: (continued)

11. Laser cutting apertures with trapezoidal walls and rounded corners may offer better paste release. IPC-7525 may have alternate design recommendations.
12. Board assembly site may have different recommendations for stencil design.



D0008A

PACKAGE OUTLINE

SOIC - 1.75 mm max height

SMALL OUTLINE INTEGRATED CIRCUIT



4214825/C 02/2019

NOTES:

1. Linear dimensions are in inches [millimeters]. Dimensions in parenthesis are for reference only. Controlling dimensions are in inches. Dimensioning and tolerancing per ASME Y14.5M.
2. This drawing is subject to change without notice.
3. This dimension does not include mold flash, protrusions, or gate burrs. Mold flash, protrusions, or gate burrs shall not exceed $.006$ [0.15] per side.
4. This dimension does not include interlead flash.
5. Reference JEDEC registration MS-012, variation AA.

EXAMPLE BOARD LAYOUT

D0008A

SOIC - 1.75 mm max height

SMALL OUTLINE INTEGRATED CIRCUIT



LAND PATTERN EXAMPLE
 EXPOSED METAL SHOWN
 SCALE:8X



SOLDER MASK DETAILS

4214825/C 02/2019

NOTES: (continued)

- 6. Publication IPC-7351 may have alternate designs.
- 7. Solder mask tolerances between and around signal pads can vary based on board fabrication site.

EXAMPLE STENCIL DESIGN

D0008A

SOIC - 1.75 mm max height

SMALL OUTLINE INTEGRATED CIRCUIT



SOLDER PASTE EXAMPLE
BASED ON .005 INCH [0.125 MM] THICK STENCIL
SCALE:8X

4214825/C 02/2019

NOTES: (continued)

8. Laser cutting apertures with trapezoidal walls and rounded corners may offer better paste release. IPC-7525 may have alternate design recommendations.
9. Board assembly site may have different recommendations for stencil design.

IMPORTANT NOTICE AND DISCLAIMER

TI PROVIDES TECHNICAL AND RELIABILITY DATA (INCLUDING DATASHEETS), DESIGN RESOURCES (INCLUDING REFERENCE DESIGNS), APPLICATION OR OTHER DESIGN ADVICE, WEB TOOLS, SAFETY INFORMATION, AND OTHER RESOURCES "AS IS" AND WITH ALL FAULTS, AND DISCLAIMS ALL WARRANTIES, EXPRESS AND IMPLIED, INCLUDING WITHOUT LIMITATION ANY IMPLIED WARRANTIES OF MERCHANTABILITY, FITNESS FOR A PARTICULAR PURPOSE OR NON-INFRINGEMENT OF THIRD PARTY INTELLECTUAL PROPERTY RIGHTS.

These resources are intended for skilled developers designing with TI products. You are solely responsible for (1) selecting the appropriate TI products for your application, (2) designing, validating and testing your application, and (3) ensuring your application meets applicable standards, and any other safety, security, or other requirements. These resources are subject to change without notice. TI grants you permission to use these resources only for development of an application that uses the TI products described in the resource. Other reproduction and display of these resources is prohibited. No license is granted to any other TI intellectual property right or to any third party intellectual property right. TI disclaims responsibility for, and you will fully indemnify TI and its representatives against, any claims, damages, costs, losses, and liabilities arising out of your use of these resources.

TI's products are provided subject to TI's Terms of Sale (www.ti.com/legal/termsofsale.html) or other applicable terms available either on ti.com or provided in conjunction with such TI products. TI's provision of these resources does not expand or otherwise alter TI's applicable warranties or warranty disclaimers for TI products.

Mailing Address: Texas Instruments, Post Office Box 655303, Dallas, Texas 75265
Copyright © 2019, Texas Instruments Incorporated

Looking for pricing, stock, or lifecycle information?

Click below to explore more details on WIN SOURCE:

- ⊖ [View LM3404HVMRX/NOPB on WIN SOURCE](#)
- ⊖ [Texas Instruments](#) Information

Optimize Your Supply Chain with WIN SOURCE Solutions

- ✓ Global Sourcing Solution
- ✓ Obsolete Management
- ✓ Cost Control Management
- ✓ Shortage Management
- ✓ Alternative Solution
- ✓ Excess Inventory Management