



**THE DATASHEET OF
LM336MX-5.0**



LM136-5.0, LM236-5.0, LM336-5.0 5.0V Reference Diode

 Check for Samples: [LM136-5.0](#), [LM236-5.0](#), [LM336-5.0](#)

FEATURES

- Adjustable 4V to 6V
- Low Temperature Coefficient
- Wide Operating Current of 600 μ A to 10 mA
- 0.6 Ω Dynamic Impedance
- \pm 1% Initial Tolerance Available
- Specified Temperature Stability
- Easily Trimmed for Minimum Temperature Drift
- Fast Turn-on
- Three Lead Transistor Package

DESCRIPTION

The LM136-5.0/LM236-5.0/LM336-5.0 integrated circuits are precision 5.0V shunt regulator diodes. These monolithic IC voltage references operate as a low temperature coefficient 5.0V zener with 0.6 Ω dynamic impedance. A third terminal on the LM136-5.0 allows the reference voltage and temperature coefficient to be trimmed easily.

The LM136-5.0 series is useful as a precision 5.0V low voltage reference for digital voltmeters, power supplies or op amp circuitry. The 5.0V makes it convenient to obtain a stable reference from low voltage supplies. Further, since the LM136-5.0 operates as a shunt regulator, it can be used as either a positive or negative voltage reference.

The LM136-5.0 is rated for operation over -55°C to $+125^{\circ}\text{C}$ while the LM236-5.0 is rated over a -25°C to $+85^{\circ}\text{C}$ temperature range. The LM336-5.0 is rated for operation over a 0°C to $+70^{\circ}\text{C}$ temperature range. See the [Connection Diagrams](#) for available packages. For applications requiring 2.5V see LM136-2.5.

Connection Diagrams

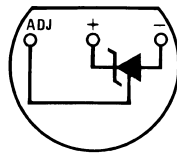

Figure 1. TO-92 Plastic Package (Bottom View)

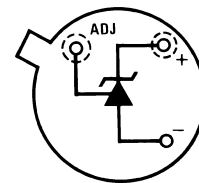

Figure 2. TO Metal Can Package (Bottom View)

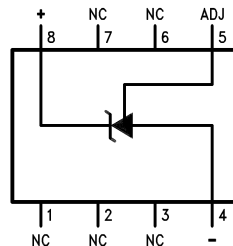

Figure 3. SOIC Package



Please be aware that an important notice concerning availability, standard warranty, and use in critical applications of Texas Instruments semiconductor products and disclaimers thereto appears at the end of this data sheet.

All trademarks are the property of their respective owners.

Typical Applications

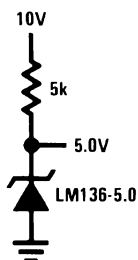
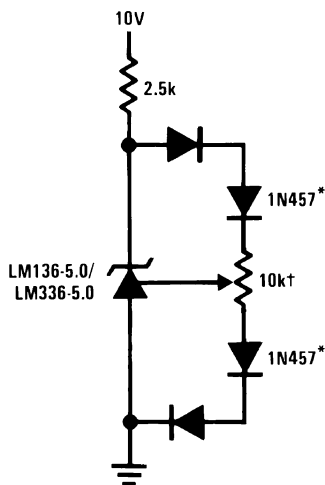

Figure 4. 5.0V Reference



† Adjust to 5.00V

* Any silicon signal diode

Figure 5. 5.0V Reference with Minimum Temperature Coefficient

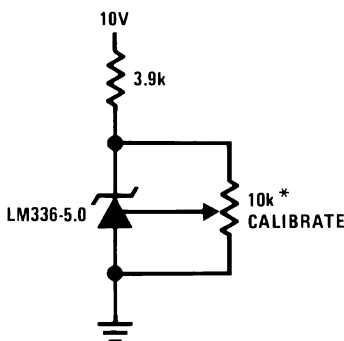

* Does not affect temperature coefficient

Figure 6. Trimmed 4V to 6V Reference with Temperature Coefficient Independent of Breakdown Voltage



These devices have limited built-in ESD protection. The leads should be shorted together or the device placed in conductive foam during storage or handling to prevent electrostatic damage to the MOS gates.

ABSOLUTE MAXIMUM RATINGS ⁽¹⁾

Reverse Current	15	mA
Forward Current	10	mA
Storage Temperature	-60 to +150	°C
Operating Temperature Range ⁽²⁾		
LM136-5.0	-55 to +150	°C
LM236-5.0	-25 to +85	°C
LM336-5.0	0 to +70	°C
Soldering Information		
TO-92 Package (10 sec.)	260	°C
TO Package (10 sec.)	300	°C
SOIC Package		
Vapor Phase (60 sec.)	215	°C
Infrared (15 sec.)	220	°C

(1) Absolute Maximum Ratings indicate limits beyond which damage to the device may occur. Electrical specifications do not apply when operating the device beyond its specified operating conditions.

(2) For elevated temperature operation, T_j max see [THERMAL CHARACTERISTICS](#)

THERMAL CHARACTERISTICS

over operating free-air temperature range (unless otherwise noted)

	LM136	150°C	
	LM236	125°C	
	LM336	100°C	
Thermal Resistance	TO-92	TO	SOIC-8
θ_{ja} (Junction to Ambient)	180°C/W (0.4" Leads)	440°C/W	165°C/W
	170°C/W (0.125" Leads)		
θ_{jc} (Junction to Case)	N/A	80°C/W	N/A

ELECTRICAL CHARACTERISTICS

Parameter	Conditions	LM136A-5.0/LM236A-5.0			LM336B-5.0			Units
		LM136-5.0/LM236-5.0			LM336-5.0			
		Min	Typ	Max	Min	Typ	Max	
Reverse Breakdown Voltage	$T_A=25^\circ\text{C}$, $I_R=1\text{ mA}$							
	LM136-5.0/LM236-5.0/LM336-5.0	4.9	5.00	5.1	4.8	5.00	5.2	V
	LM136A-5.0/LM236A-5.0, LM336B-5.0	4.95	5.00	5.05	4.90	5.00	5.1	V
Reverse Breakdown Change	$T_A=25^\circ\text{C}$,		6	12		6	20	mV
With Current	$600\ \mu\text{A} \leq I_R \leq 10\text{ mA}$							
Reverse Dynamic Impedance	$T_A=25^\circ\text{C}$, $I_R=1\text{ mA}$, $f = 100\text{ Hz}$		0.6	1.2		0.6	2	Ω
Temperature Stability ⁽²⁾	V_R Adjusted 5.00V $I_R=1\text{ mA}$, (Figure 15) $0^\circ\text{C} \leq T_A \leq 70^\circ\text{C}$ (LM336-5.0)					4	12	mV

(1) Unless otherwise specified, the LM136-5.0 is specified from $-55^\circ\text{C} \leq T_A \leq +125^\circ\text{C}$, the LM236-5.0 from $-25^\circ\text{C} \leq T_A \leq +85^\circ\text{C}$ and the LM336-5.0 from $0^\circ\text{C} \leq T_A \leq +70^\circ\text{C}$.

(2) Temperature stability for the LM336 and LM236 family is specified by design. Design limits are specified (but not 100% percent production tested) over the indicated temperature and supply voltage ranges. These limits are not used to calculate outgoing quality levels. Stability is defined as the maximum change in V_{REF} from 25°C to $T_A(\text{min})$ or $T_A(\text{max})$.

ELECTRICAL CHARACTERISTICS (continued)

(1)

Parameter	Conditions	LM136A-5.0/LM236A-5.0			LM336B-5.0			Units
		LM136-5.0/LM236-5.0			LM336-5.0			
		Min	Typ	Max	Min	Typ	Max	
	-25°C ≤ T _A ≤ +85°C (LM236-5.0)		7	18				mV
	-55°C ≤ T _A ≤ +125°C (LM136-5.0)		20	36				mV
Reverse Breakdown Change With Current	600 μA ≤ I _R ≤ 10 mA		6	17		6	24	mV
Adjustment Range	Circuit of Figure 14		±1			±1		V
Reverse Dynamic Impedance	I _R = 1 mA		0.8	1.6		0.8	2.5	Ω
Long Term Stability	T _A = 25°C ± 0.1°C, I _R = 1 mA, t = 1000 hrs		20			20		ppm

TYPICAL PERFORMANCE CHARACTERISTICS

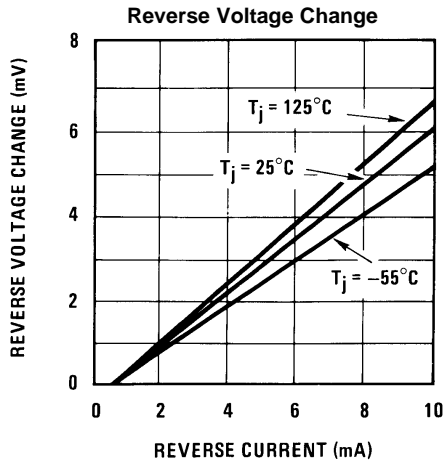

Figure 7.

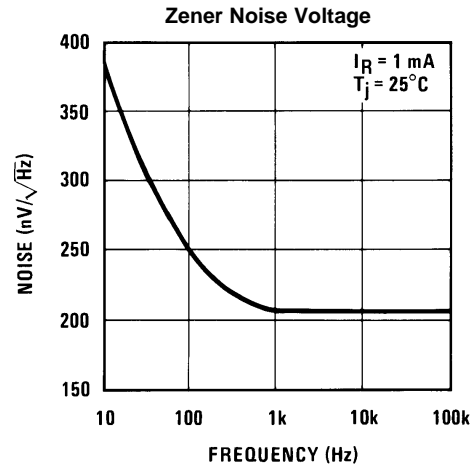

Figure 8.

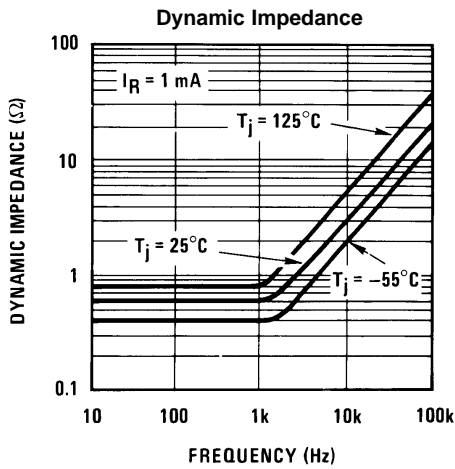

Figure 9.

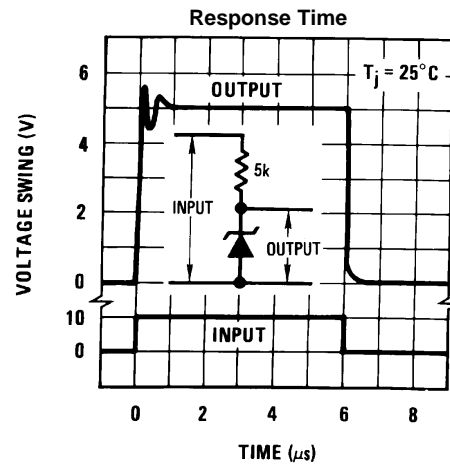

Figure 10.

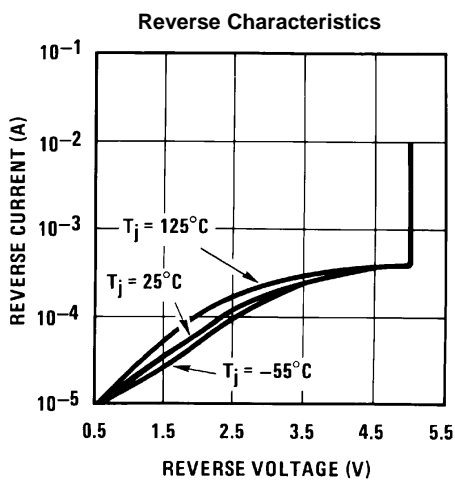

Figure 11.

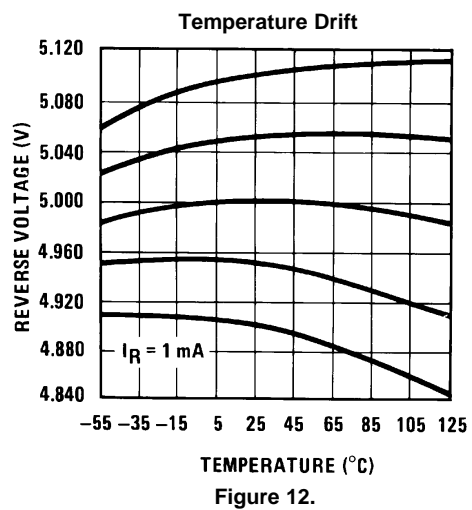

Figure 12.

TYPICAL PERFORMANCE CHARACTERISTICS (continued)

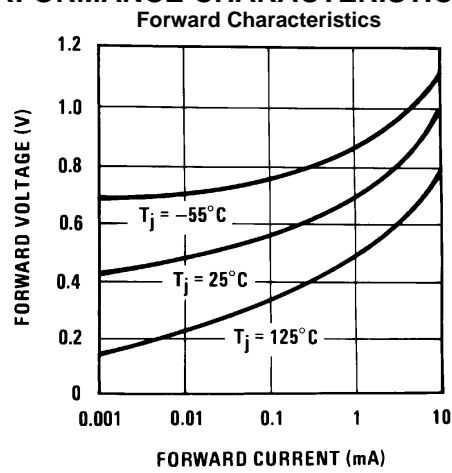

Figure 13.

APPLICATION HINTS

The LM136-5.0 series voltage references are much easier to use than ordinary zener diodes. Their low impedance and wide operating current range simplify biasing in almost any circuit. Further, either the breakdown voltage or the temperature coefficient can be adjusted to optimize circuit performance.

Figure 14 shows an LM136-5.0 with a 10k potentiometer for adjusting the reverse breakdown voltage. With the addition of R1 the breakdown voltage can be adjusted without affecting the temperature coefficient of the device. The adjustment range is usually sufficient to adjust for both the initial device tolerance and inaccuracies in buffer circuitry.

If minimum temperature coefficient is desired, four diodes can be added in series with the adjustment potentiometer as shown in Figure 15. When the device is adjusted to 5.00V the temperature coefficient is minimized. Almost any silicon signal diode can be used for this purpose such as a 1N914, 1N4148 or a 1N457. For proper temperature compensation the diodes should be in the same thermal environment as the LM136-5.0. It is usually sufficient to mount the diodes near the LM136-5.0 on the printed circuit board. The absolute resistance of the network is not critical and any value from 2k to 20k will work. Because of the wide adjustment range, fixed resistors should be connected in series with the pot to make pot setting less critical.

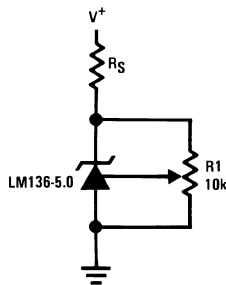

Figure 14. LM136-5.0 with Pot for Adjustment of Breakdown Voltage (Trim Range = ±1.0V Typical)

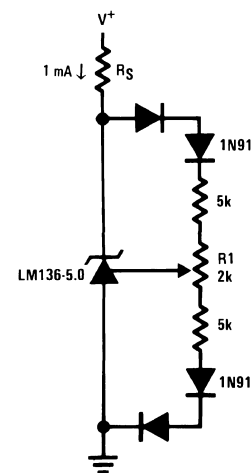
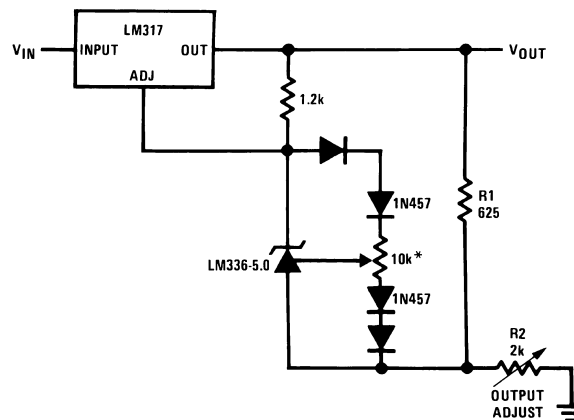

Figure 15. Temperature Coefficient Adjustment (Trim Range = ±0.5V Typical)

Typical Applications



* Adjust for 6.25V across R1

Figure 16. Precision Power Regulator with Low Temperature Coefficient

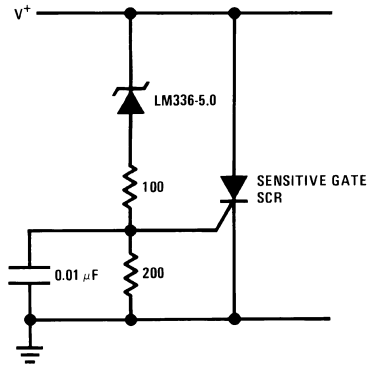

Figure 17. 5V Crowbar

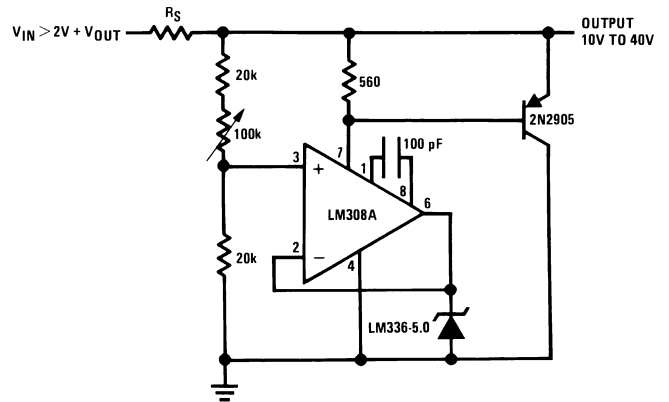

Figure 18. Adjustable Shunt Regulator

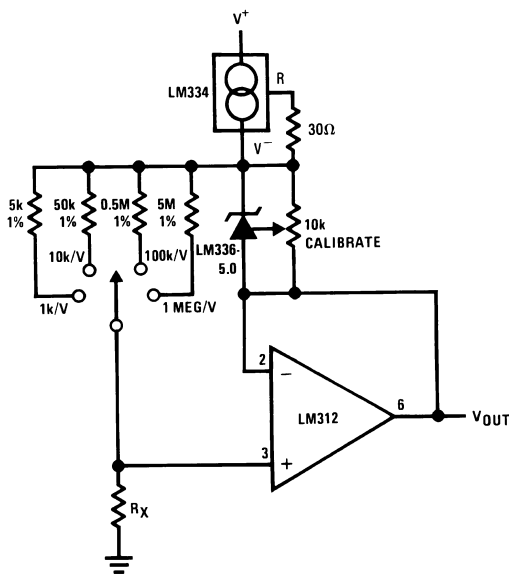

Figure 19. Linear Ohmmeter

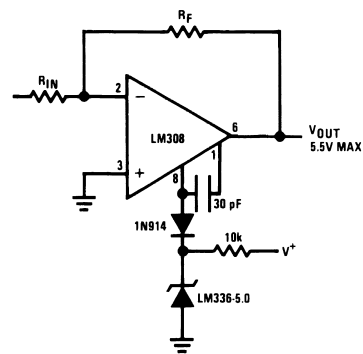

Figure 20. Op Amp with Output Clamped

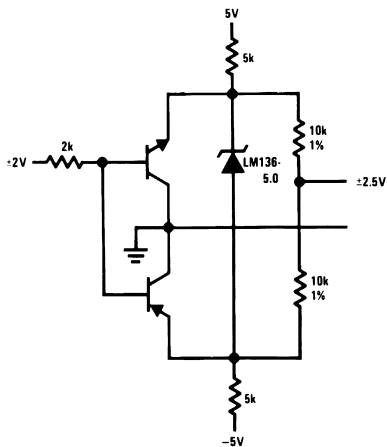

Figure 21. Bipolar Output Reference

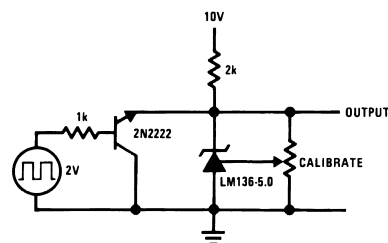

Figure 22. 5.0V Square Wave Calibrator

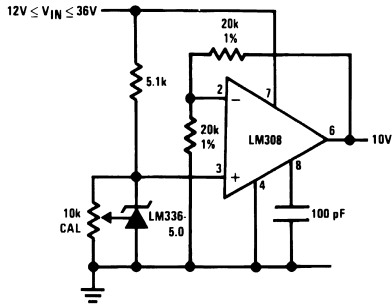

Figure 23. 10V Buffered Reference

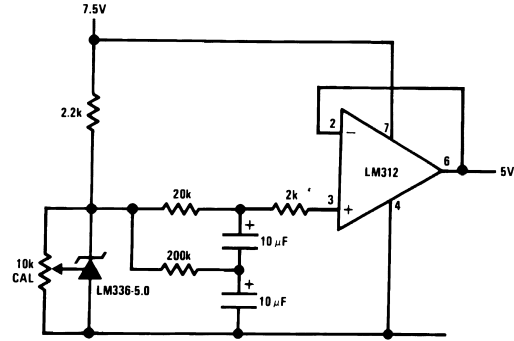

Figure 24. Low Noise Buffered Reference

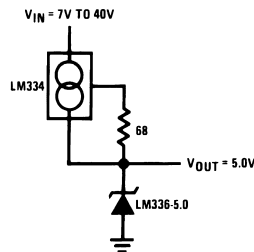
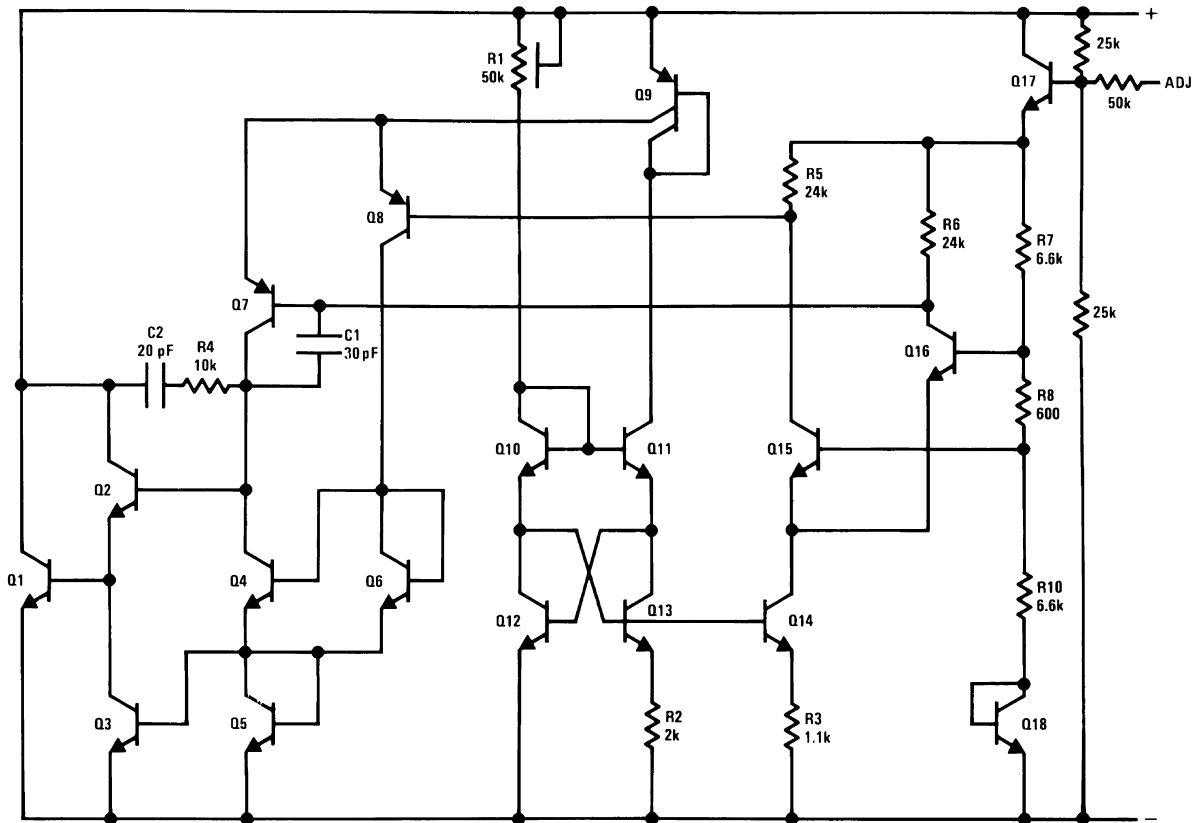

Figure 25. Wide Input Range Reference

Schematic Diagram



REVISION HISTORY

Changes from Revision C (March 2013) to Revision D	Page
• Changed layout of National Data Sheet to TI format	9

PACKAGING INFORMATION

Orderable Device	Status (1)	Package Type	Package Drawing	Pins	Package Qty	Eco Plan (2)	Lead finish/ Ball material (6)	MSL Peak Temp (3)	Op Temp (°C)	Device Marking (4/5)	Samples
LM136-5.0-MW8	ACTIVE	WAFERSALE	YS	0	1	RoHS & Green	Call TI	Level-1-NA-UNLIM	-55 to 125		Samples
LM136AH-5.0	ACTIVE	TO	NDV	3	1000	Non-RoHS & Green	Call TI	Level-1-NA-UNLIM	-40 to 125	(LM136AH5.0, LM136AH5.0)	Samples
LM136AH-5.0/NOPB	ACTIVE	TO	NDV	3	1000	RoHS & Green	Call TI	Level-1-NA-UNLIM	-40 to 125	(LM136AH5.0, LM136AH5.0)	Samples
LM136H-5.0	ACTIVE	TO	NDV	3	1000	Non-RoHS & Green	Call TI	Level-1-NA-UNLIM	-55 to 125	(LM136H5.0, LM136H5.0)	Samples
LM136H-5.0/NOPB	ACTIVE	TO	NDV	3	1000	RoHS & Green	Call TI	Level-1-NA-UNLIM	-55 to 125	(LM136H5.0, LM136H5.0)	Samples
LM236AH-5.0/NOPB	ACTIVE	TO	NDV	3	1000	RoHS & Green	Call TI	Level-1-NA-UNLIM	-55 to 125	(LM236AH5.0, LM236AH5.0)	Samples
LM236H-5.0	ACTIVE	TO	NDV	3	1000	Non-RoHS & Green	Call TI	Level-1-NA-UNLIM	-25 to 85	(LM236H5.0, LM236H5.0)	Samples
LM236H-5.0/NOPB	ACTIVE	TO	NDV	3	1000	RoHS & Green	Call TI	Level-1-NA-UNLIM	-25 to 85	(LM236H5.0, LM236H5.0)	Samples
LM336-5 MWC	ACTIVE	WAFERSALE	YS	0	1	RoHS & Green	Call TI	Level-1-NA-UNLIM	-40 to 85		Samples
LM336BM-5.0/NOPB	ACTIVE	SOIC	D	8	95	RoHS & Green	SN	Level-1-260C-UNLIM	0 to 70	LM336BM5.0	Samples
LM336BMX-5.0/NOPB	ACTIVE	SOIC	D	8	2500	RoHS & Green	SN	Level-1-260C-UNLIM	0 to 70	LM336BM5.0	Samples
LM336BZ-5.0/NOPB	ACTIVE	TO-92	LP	3	1800	RoHS & Green	Call TI	N / A for Pkg Type	0 to 70	LM336BZ5.0	Samples
LM336M-5.0/NOPB	ACTIVE	SOIC	D	8	95	RoHS & Green	SN	Level-1-260C-UNLIM	0 to 70	LM336M5.0	Samples
LM336MX-5.0/NOPB	ACTIVE	SOIC	D	8	2500	RoHS & Green	SN	Level-1-260C-UNLIM	0 to 70	LM336M5.0	Samples
LM336Z-5.0/NOPB	ACTIVE	TO-92	LP	3	1800	RoHS & Green	Call TI	N / A for Pkg Type	0 to 70	LM336Z-5.0	Samples

(1) The marketing status values are defined as follows:

ACTIVE: Product device recommended for new designs.

LIFEBUY: TI has announced that the device will be discontinued, and a lifetime-buy period is in effect.

NRND: Not recommended for new designs. Device is in production to support existing customers, but TI does not recommend using this part in a new design.

PREVIEW: Device has been announced but is not in production. Samples may or may not be available.

OBSOLETE: TI has discontinued the production of the device.

(2) RoHS: TI defines "RoHS" to mean semiconductor products that are compliant with the current EU RoHS requirements for all 10 RoHS substances, including the requirement that RoHS substance do not exceed 0.1% by weight in homogeneous materials. Where designed to be soldered at high temperatures, "RoHS" products are suitable for use in specified lead-free processes. TI may reference these types of products as "Pb-Free".

RoHS Exempt: TI defines "RoHS Exempt" to mean products that contain lead but are compliant with EU RoHS pursuant to a specific EU RoHS exemption.

Green: TI defines "Green" to mean the content of Chlorine (Cl) and Bromine (Br) based flame retardants meet JS709B low halogen requirements of ≤ 1000 ppm threshold. Antimony trioxide based flame retardants must also meet the ≤ 1000 ppm threshold requirement.

(3) MSL, Peak Temp. - The Moisture Sensitivity Level rating according to the JEDEC industry standard classifications, and peak solder temperature.

(4) There may be additional marking, which relates to the logo, the lot trace code information, or the environmental category on the device.

(5) Multiple Device Markings will be inside parentheses. Only one Device Marking contained in parentheses and separated by a "~" will appear on a device. If a line is indented then it is a continuation of the previous line and the two combined represent the entire Device Marking for that device.

(6) Lead finish/Ball material - Orderable Devices may have multiple material finish options. Finish options are separated by a vertical ruled line. Lead finish/Ball material values may wrap to two lines if the finish value exceeds the maximum column width.

Important Information and Disclaimer: The information provided on this page represents TI's knowledge and belief as of the date that it is provided. TI bases its knowledge and belief on information provided by third parties, and makes no representation or warranty as to the accuracy of such information. Efforts are underway to better integrate information from third parties. TI has taken and continues to take reasonable steps to provide representative and accurate information but may not have conducted destructive testing or chemical analysis on incoming materials and chemicals. TI and TI suppliers consider certain information to be proprietary, and thus CAS numbers and other limited information may not be available for release.

In no event shall TI's liability arising out of such information exceed the total purchase price of the TI part(s) at issue in this document sold by TI to Customer on an annual basis.

TAPE AND REEL INFORMATION

QUADRANT ASSIGNMENTS FOR PIN 1 ORIENTATION IN TAPE

*All dimensions are nominal

Device	Package Type	Package Drawing	Pins	SPQ	Reel Diameter (mm)	Reel Width W1 (mm)	A0 (mm)	B0 (mm)	K0 (mm)	P1 (mm)	W (mm)	Pin1 Quadrant
LM336BMX-5.0/NOPB	SOIC	D	8	2500	330.0	12.4	6.5	5.4	2.0	8.0	12.0	Q1
LM336MX-5.0/NOPB	SOIC	D	8	2500	330.0	12.4	6.5	5.4	2.0	8.0	12.0	Q1

TAPE AND REEL BOX DIMENSIONS



*All dimensions are nominal

Device	Package Type	Package Drawing	Pins	SPQ	Length (mm)	Width (mm)	Height (mm)
LM336BMX-5.0/NOPB	SOIC	D	8	2500	367.0	367.0	35.0
LM336MX-5.0/NOPB	SOIC	D	8	2500	367.0	367.0	35.0

TUBE

*All dimensions are nominal

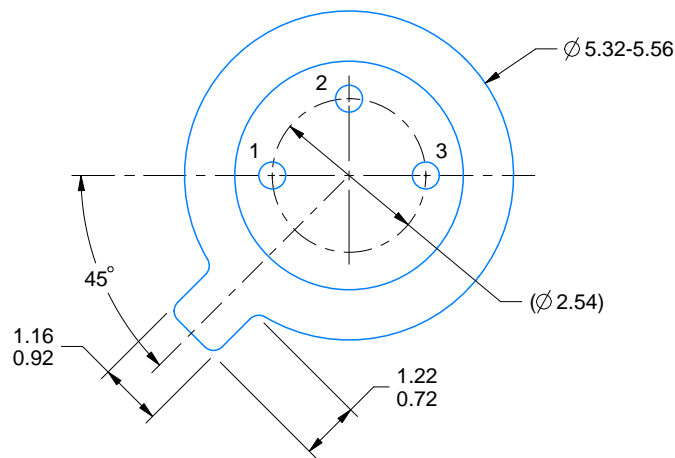
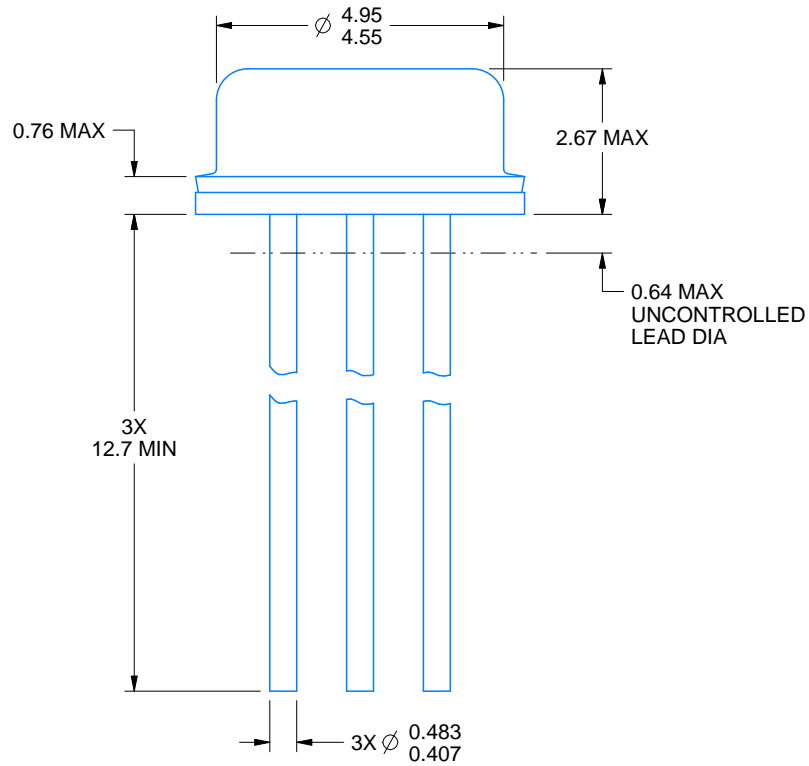
Device	Package Name	Package Type	Pins	SPQ	L (mm)	W (mm)	T (μm)	B (mm)
LM336BM-5.0/NOPB	D	SOIC	8	95	495	8	4064	3.05
LM336M-5.0/NOPB	D	SOIC	8	95	495	8	4064	3.05



4219876/A 01/2017

NOTES:

1. All linear dimensions are in millimeters. Any dimensions in parenthesis are for reference only. Dimensioning and tolerancing per ASME Y14.5M.
2. This drawing is subject to change without notice.
3. Reference JEDEC registration TO-46.

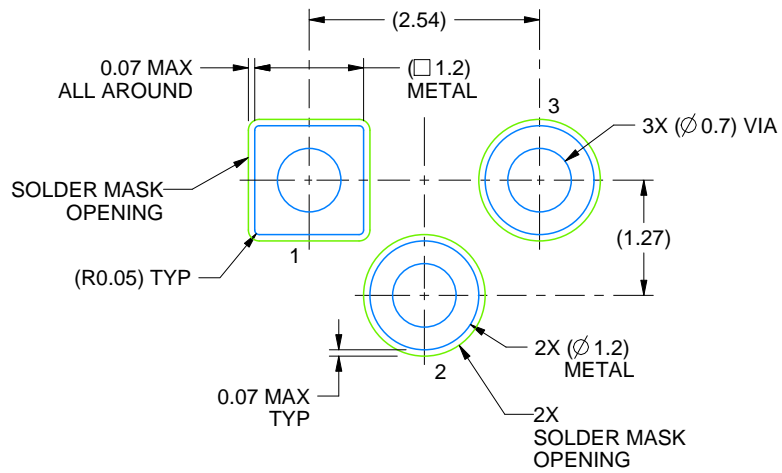

LAND PATTERN EXAMPLE
NON-SOLDER MASK DEFINED
SCALE:12X



D0008A

PACKAGE OUTLINE

SOIC - 1.75 mm max height

SMALL OUTLINE INTEGRATED CIRCUIT



NOTES:

1. Linear dimensions are in inches [millimeters]. Dimensions in parenthesis are for reference only. Controlling dimensions are in inches. Dimensioning and tolerancing per ASME Y14.5M.
2. This drawing is subject to change without notice.
3. This dimension does not include mold flash, protrusions, or gate burrs. Mold flash, protrusions, or gate burrs shall not exceed .006 [0.15] per side.
4. This dimension does not include interlead flash.
5. Reference JEDEC registration MS-012, variation AA.

EXAMPLE BOARD LAYOUT

D0008A

SOIC - 1.75 mm max height

SMALL OUTLINE INTEGRATED CIRCUIT



LAND PATTERN EXAMPLE
EXPOSED METAL SHOWN
SCALE:8X



SOLDER MASK DETAILS

4214825/C 02/2019

NOTES: (continued)

6. Publication IPC-7351 may have alternate designs.

7. Solder mask tolerances between and around signal pads can vary based on board fabrication site.

EXAMPLE STENCIL DESIGN

D0008A

SOIC - 1.75 mm max height

SMALL OUTLINE INTEGRATED CIRCUIT



SOLDER PASTE EXAMPLE
BASED ON .005 INCH [0.125 MM] THICK STENCIL
SCALE:8X

4214825/C 02/2019

NOTES: (continued)

8. Laser cutting apertures with trapezoidal walls and rounded corners may offer better paste release. IPC-7525 may have alternate design recommendations.
9. Board assembly site may have different recommendations for stencil design.

GENERIC PACKAGE VIEW

LP 3

TO-92 - 5.34 mm max height

TRANSISTOR OUTLINE



Images above are just a representation of the package family, actual package may vary.
Refer to the product data sheet for package details.

4040001-2/F

LP0003A



PACKAGE OUTLINE

TO-92 - 5.34 mm max height

TO-92



4215214/B 04/2017

NOTES:

1. All linear dimensions are in millimeters. Any dimensions in parenthesis are for reference only. Dimensioning and tolerancing per ASME Y14.5M.
2. This drawing is subject to change without notice.
3. Lead dimensions are not controlled within this area.
4. Reference JEDEC TO-226, variation AA.
5. Shipping method:
 - a. Straight lead option available in bulk pack only.
 - b. Formed lead option available in tape and reel or ammo pack.
 - c. Specific products can be offered in limited combinations of shipping medium and lead options.
 - d. Consult product folder for more information on available options.

EXAMPLE BOARD LAYOUT

LP0003A

TO-92 - 5.34 mm max height

TO-92

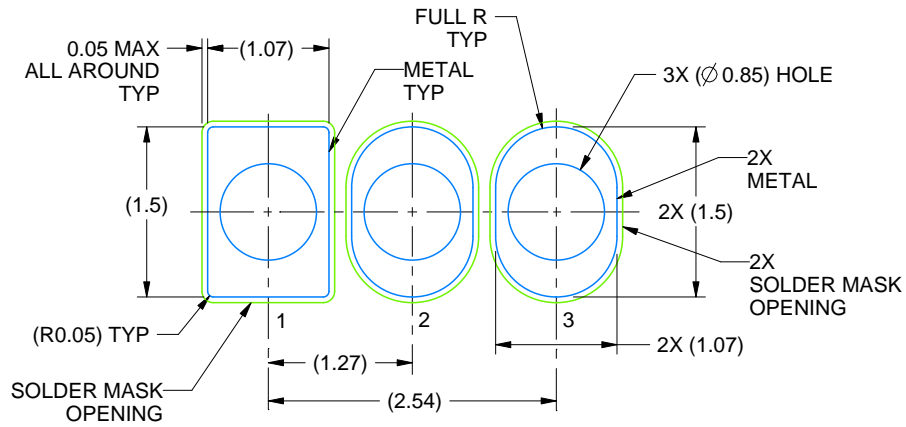

LAND PATTERN EXAMPLE
STRAIGHT LEAD OPTION
NON-SOLDER MASK DEFINED
SCALE:15X

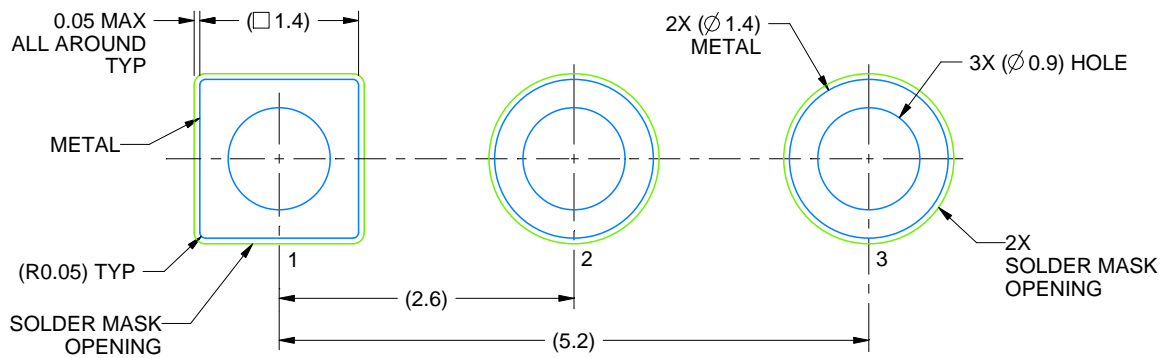

LAND PATTERN EXAMPLE
FORMED LEAD OPTION
NON-SOLDER MASK DEFINED
SCALE:15X

4215214/B 04/2017

TAPE SPECIFICATIONS

LP0003A

TO-92 - 5.34 mm max height

TO-92



FOR FORMED LEAD OPTION PACKAGE

4215214/B 04/2017

IMPORTANT NOTICE AND DISCLAIMER

TI PROVIDES TECHNICAL AND RELIABILITY DATA (INCLUDING DATA SHEETS), DESIGN RESOURCES (INCLUDING REFERENCE DESIGNS), APPLICATION OR OTHER DESIGN ADVICE, WEB TOOLS, SAFETY INFORMATION, AND OTHER RESOURCES "AS IS" AND WITH ALL FAULTS, AND DISCLAIMS ALL WARRANTIES, EXPRESS AND IMPLIED, INCLUDING WITHOUT LIMITATION ANY IMPLIED WARRANTIES OF MERCHANTABILITY, FITNESS FOR A PARTICULAR PURPOSE OR NON-INFRINGEMENT OF THIRD PARTY INTELLECTUAL PROPERTY RIGHTS.

These resources are intended for skilled developers designing with TI products. You are solely responsible for (1) selecting the appropriate TI products for your application, (2) designing, validating and testing your application, and (3) ensuring your application meets applicable standards, and any other safety, security, regulatory or other requirements.

These resources are subject to change without notice. TI grants you permission to use these resources only for development of an application that uses the TI products described in the resource. Other reproduction and display of these resources is prohibited. No license is granted to any other TI intellectual property right or to any third party intellectual property right. TI disclaims responsibility for, and you will fully indemnify TI and its representatives against, any claims, damages, costs, losses, and liabilities arising out of your use of these resources.

TI's products are provided subject to [TI's Terms of Sale](#) or other applicable terms available either on [ti.com](https://www.ti.com) or provided in conjunction with such TI products. TI's provision of these resources does not expand or otherwise alter TI's applicable warranties or warranty disclaimers for TI products.

TI objects to and rejects any additional or different terms you may have proposed.

Mailing Address: Texas Instruments, Post Office Box 655303, Dallas, Texas 75265
Copyright © 2024, Texas Instruments Incorporated

Looking for pricing, stock, or lifecycle information?

Click below to explore more details on WIN SOURCE:

 [View LM336MX-5.0](#) on WIN SOURCE

 [Texas Instruments](#) Information

Optimize Your Supply Chain with WIN SOURCE Solutions

-  Global Sourcing Solution
-  Obsolete Management
-  Cost Control Management
-  Shortage Management
-  Alternative Solution
-  Excess Inventory Management