



THE DATASHEET OF LM2984T/NOPB



LM2984 Microprocessor Power Supply System

Check for Samples: [LM2984](#)

FEATURES

- Three Low Dropout Tracking Regulators
- Output Current in Excess of 500 mA
- Fully Specified for -40°C to $+125^{\circ}\text{C}$ Operation
- Low Quiescent Current Standby Regulator
- Microprocessor Malfunction RESET Flag
- Delayed RESET on Power-Up
- Accurate pretrimmed 5V outputs
- Reverse Battery Protection
- Overvoltage Protection
- Reverse Transient Protection
- Short Circuit Protection
- Internal Thermal Overload Protection
- ON/OFF Switch for High Current Outputs
- P⁺ Product Enhancement Tested

DESCRIPTION

The LM2984 positive voltage regulator features three independent and tracking outputs capable of delivering the power for logic circuits, peripheral sensors and standby memory in a typical microprocessor system. The LM2984 includes circuitry which monitors both its own high-current output and also an external μP . If any error conditions are sensed in either, a reset error flag is set and maintained until the malfunction terminates. Since these functions are included in the same package with the three regulators, a great saving in board space can be realized in the typical microprocessor system. The LM2984 also features very low dropout voltages on each of its three regulator outputs (0.6V at the rated output current). Furthermore, the quiescent current can be reduced to 1 mA in the standby mode.

Designed also for vehicular applications, the LM2984 and all regulated circuitry are protected from reverse battery installations or 2-battery jumps. Familiar regulator features such as short circuit and thermal overload protection are also provided. Fixed outputs of 5V are available in the plastic TO-220 power package.

Typical Application Circuit

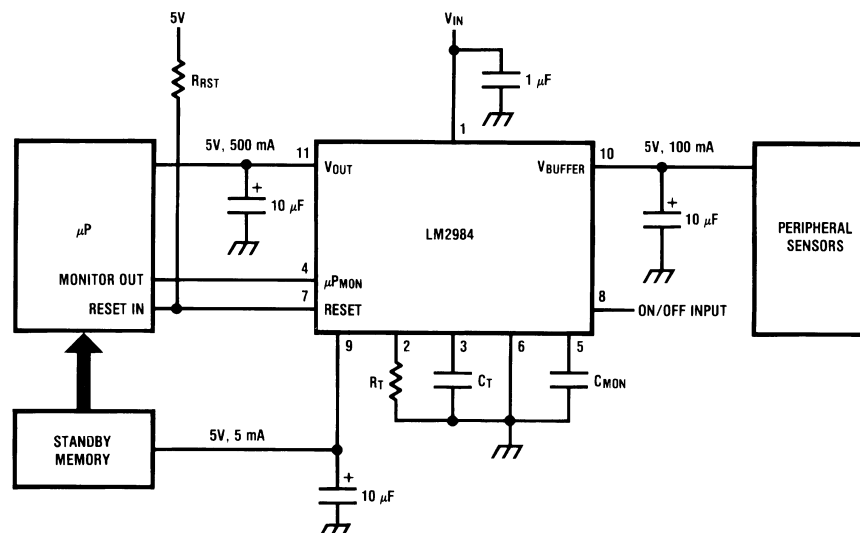

C_{OUT} must be at least $10\ \mu\text{F}$ to maintain stability. May be increased without bound to maintain regulation during transients. Locate as close as possible to the regulator. This capacitor must be rated over the same operating temperature range as the regulator. The equivalent series resistance (ESR) of this capacitor is critical; see [curves](#).

Figure 1. Package Number NDJ0011B



Please be aware that an important notice concerning availability, standard warranty, and use in critical applications of Texas Instruments semiconductor products and disclaimers thereto appears at the end of this data sheet.

All trademarks are the property of their respective owners.



These devices have limited built-in ESD protection. The leads should be shorted together or the device placed in conductive foam during storage or handling to prevent electrostatic damage to the MOS gates.

Absolute Maximum Ratings ⁽¹⁾⁽²⁾

Input Voltage	
Survival Voltage (<100 ms)	60V
Operational Voltage	26V
Internal Power Dissipation	Internally Limited
Operating Temperature Range (T _A)	-40°C to +125°C
Maximum Junction Temperature	
(3)	150°C
Storage Temperature Range	-65°C to +150°C
Lead Temperature	
(Soldering, 10 sec.)	230°C
ESD Susceptability ⁽⁴⁾	2000V

- (1) Absolute Maximum Ratings indicate limits beyond which damage to the device may occur. DC and AC electrical specifications do not apply when operating the device beyond its specified operating ratings.
- (2) If Military/Aerospace specified devices are required, please contact the Texas Instruments Sales Office/ Distributors for availability and specifications.
- (3) Thermal resistance without a heatsink for junction-to-case temperature is 3°C/W. Thermal resistance case-to-ambient is 40°C/W.
- (4) Human body model, 100 pF capacitor discharged through a 1500Ω resistor.

Electrical Characteristics

V_{IN} = 14V, I_{OUT} = 5 mA, C_{OUT} = 10 μF, unless otherwise indicated. **Boldface** type refers to limits over the entire operating temperature range, -40°C ≤ T_A ≤ +125°C, all other limits are for T_A = T_j = 25°C ⁽¹⁾.

Parameter	Conditions	Typical	Limit (2)	Units
V_{OUT} (Pin 11)				
Output Voltage	5 mA ≤ I _O ≤ 500 mA 6V ≤ V _{IN} ≤ 26V	5.00	4.85/ 4.75 5.15/ 5.25	V _{min} V _{max}
Line Regulation	9V ≤ V _{IN} ≤ 16V 7V ≤ V _{IN} ≤ 26V	2 5	25/25 50/50	mV _{max} mV _{max}
Load Regulation	5 mA ≤ I _{OUT} ≤ 500 mA	12	50/50	mV _{max}
Output Impedance	250 mA _{dc} and 10 mA _{rms} , f _o = 120 Hz	24		mΩ
Quiescent Current	I _{OUT} = 500 mA I _{OUT} = 250 mA	38 14	100/100 50/50	mA _{max} mA _{max}
Output Noise Voltage	10 Hz–100 kHz, I _{OUT} = 100 mA	100		μV
Long Term Stability		20		mV/1000 hr
Ripple Rejection	f _o = 120 Hz	70	60/50	dB _{min}
Dropout Voltage	I _{OUT} = 500 mA I _{OUT} = 250 mA	0.53 0.28	0.80/1.1 0.50/0.70	V _{max} V _{max}
Current Limit		0.92	0.75/0.60	A _{min}
Maximum Operational Input Voltage	Continuous DC	32	26/26	V _{min}
Maximum Line Transient	V _{OUT} ≤ 6V, R _{OUT} = 100Ω, T ≤ 100 ms	65	60/60	V _{min}
Reverse Polarity Input Voltage DC	V _{OUT} ≥ -0.6V, R _{OUT} = 100Ω	-30	-15/-15	V _{min}
Reverse Polarity Input Voltage Transient	T ≤ 100 ms, R _{OUT} = 100Ω	-55	-35/-35	V _{min}

(1) To ensure constant junction temperature, low duty cycle pulse testing is used.

(2) Tested Limits are ensured and 100% production tested.

Electrical Characteristics (continued)

$V_{IN} = 14V$, $I_{OUT} = 5\text{ mA}$, $C_{OUT} = 10\text{ }\mu\text{F}$, unless otherwise indicated. **Boldface** type refers to limits over the entire operating temperature range, $-40^{\circ}\text{C} \leq T_A \leq +125^{\circ}\text{C}$, all other limits are for $T_A = T_j = 25^{\circ}\text{C}$ ⁽¹⁾.

Parameter	Conditions	Typical	Limit (2)	Units
V_{buffer} (Pin 10)				
Output Voltage	$5\text{ mA} \leq I_O \leq 100\text{ mA}$ $6V \leq V_{IN} \leq 26V$	5.00	4.85/4.75 5.15/5.25	V_{min} V_{max}
Line Regulation	$9V \leq V_{IN} \leq 16V$	2	25/25	mV_{max}
	$7V \leq V_{IN} \leq 26V$	5	50/50	mV_{max}
Load Regulation	$5\text{ mA} \leq I_{buf} \leq 100\text{ mA}$	15	50/50	mV_{max}
Output Impedance	50 mA_{dc} and 10 mA_{rms} , $f_o = 120\text{ Hz}$	200		$m\Omega$
Quiescent Current	$I_{buf} = 100\text{ mA}$	8.0	15/15	mA_{max}
Output Noise Voltage	10 Hz–100 kHz, $I_{OUT} = 100\text{ mA}$	100		μV
Long Term Stability		20		$mV/1000\text{ hr}$
Ripple Rejection	$f_o = 120\text{ Hz}$	70	60/50	dB_{min}
Dropout Voltage	$I_{buf} = 100\text{ mA}$	0.35	0.50/0.80	V_{max}
Current Limit		0.23	0.15/0.15	A_{min}
Maximum Operational Input Voltage	Continuous DC	32	26/26	V_{min}
Maximum Line Transient	$V_{buf} \leq 6V$, $R_{buf} = 100\Omega$, $T \leq 100\text{ ms}$	65	60/60	V_{min}
Reverse Polarity Input Voltage DC	$V_{buf} \geq -0.6V$, $R_{buf} = 100\Omega$	-30	-15/-15	V_{min}
Reverse Polarity Input Voltage Transient	$T \leq 100\text{ ms}$, $R_{buf} = 100\Omega$	-55	-35/-35	V_{min}
$V_{standby}$ (Pin 9)				
Output Voltage	$1\text{ mA} \leq I_O \leq 7.5\text{ mA}$ $6V \leq V_{IN} \leq 26V$	5.00	4.85/4.75 5.15/5.25	V_{min} V_{max}
Line Regulation	$9V \leq V_{IN} \leq 16V$	2	25/25	mV_{max}
	$7V \leq V_{IN} \leq 26V$	5	50/50	mV_{max}
Load Regulation	$0.5\text{ mA} \leq I_{OUT} \leq 7.5\text{ mA}$	6	50/50	mV_{max}
Output Impedance	5 mA_{dc} and 1 mA_{rms} , $f_o = 120\text{ Hz}$	0.9		Ω
Quiescent Current	$I_{stby} = 7.5\text{ mA}$	1.2	2.0/4.0	mA_{max}
	$I_{stby} = 2\text{ mA}$	0.9	1.5/4.0	mA_{max}
Output Noise Voltage	10 Hz–100 kHz, $I_{stby} = 1\text{ mA}$	100		μV
Long Term Stability		20		$mV/1000\text{ hr}$
Ripple Rejection	$f_o = 120\text{ Hz}$	70	60/50	dB_{min}
Dropout Voltage	$I_{stby} = 1\text{ mA}$	0.26	0.50/0.60	V_{max}
	$I_{stby} = 7.5\text{ mA}$	0.38	0.60/0.70	V_{max}
Current Limit		15	12/12	mA_{min}
Maximum Operational Input Voltage	$4.5V \leq V_{stby} \leq 6V$, $R_{stby} = 1000\Omega$	65	60/60	V_{min}
Maximum Line Transient	$V_{stby} \leq 6V$, $T \leq 100\text{ ms}$, $R_{stby} = 1000\Omega$	65	60/60	V_{min}
Reverse Polarity Input Voltage DC	$V_{stby} \geq -0.6V$, $R_{stby} = 1000\Omega$	-30	-15/-15	V_{min}

Electrical Characteristics (continued)

$V_{IN} = 14V$, $I_{OUT} = 5\text{ mA}$, $C_{OUT} = 10\text{ }\mu\text{F}$, unless otherwise indicated. **Boldface** type refers to limits over the entire operating temperature range, $-40^{\circ}\text{C} \leq T_A \leq +125^{\circ}\text{C}$, all other limits are for $T_A = T_j = 25^{\circ}\text{C}$ ⁽¹⁾.

Parameter	Conditions	Typical	Limit (2)	Units
Reverse Polarity Input Voltage Transient	$T \leq 100\text{ ms}$, $R_{stby} = 1000\Omega$	-55	-35/-35	V_{min}
Tracking and Isolation				
Tracking $V_{OUT} - V_{stby}$	$I_{OUT} \leq 500\text{ mA}$, $I_{buf} = 5\text{ mA}$, $I_{stby} \leq 7.5\text{ mA}$	± 30	$\pm 100/\pm 100$	mV_{max}
Tracking $V_{buf} - V_{stby}$	$I_{OUT} = 5\text{ mA}$, $I_{buf} \leq 100\text{ mA}$, $I_{stby} \leq 7.5\text{ mA}$	± 30	$\pm 100/\pm 100$	mV_{max}
Tracking $V_{OUT} - V_{buf}$	$I_{OUT} \leq 500\text{ mA}$, $I_{buf} \leq 100\text{ mA}$, $I_{stby} = 1\text{ mA}$	± 30	$\pm 100/\pm 100$	mV_{max}
Isolation ⁽³⁾ V_{buf} from V_{OUT}	$R_{OUT} = 1\Omega$, $I_{buf} \leq 100\text{ mA}$	5.00	4.50/ 4.50 5.50/ 5.50	V_{min} V_{max}
Isolation ⁽³⁾ V_{stby} from V_{OUT}	$R_{OUT} = 1\Omega$, $I_{stby} \leq 7.5\text{ mA}$	5.00	4.50/ 4.50 5.50/ 5.50	V_{min} V_{max}
Isolation ⁽³⁾ V_{OUT} from V_{buf}	$R_{buf} = 1\Omega$, $I_{OUT} \leq 500\text{ mA}$	5.00	4.50/ 4.50 5.50/ 5.50	V_{min} V_{max}
Isolation ⁽³⁾ V_{stby} from V_{buf}	$R_{buf} = 1\Omega$, $I_{stby} \leq 7.5\text{ mA}$	5.00	4.50/ 4.50 5.50/ 5.50	V_{min} V_{max}
Computer Monitor/Reset Functions				
$I_{reset\ Low}$	$V_{IN} = 4V$, $V_{rst} = 0.4V$	5	2/ 0.50	mA_{min}
$V_{reset\ Low}$	$V_{IN} = 4V$, $I_{rst} = 1\text{ mA}$	0.10	0.40/ 0.40	V_{max}
R_t voltage	(Pin 2)	1.22	1.15/ 0.75	V_{min}
		1.22	1.30/ 2.00	V_{max}
Power On Reset Delay	$V_{\mu P_{mon}} = 5V$ ($T_{dly} = 1.2 R_t C_t$)	50	45/ 17.0 55/ 80.0	ms_{min} ms_{max}
ΔV_{OUT} Low Reset Threshold	⁽⁴⁾	-350	-225/- 175 -500/- 550	mV_{min} mV_{max}
		600	225/ 175 750/ 800	mV_{min} mV_{max}
Reset Output Leakage	$V_{\mu P_{mon}} = 5V$, $V_{rst} = 12V$	0.01	1/ 5.0	μA_{max}
μP_{mon} Input Current (Pin 4)	$V_{\mu P_{mon}} = 2.4V$	7.5	25/ 25	μA_{max}
	$V_{\mu P_{mon}} = 0.4V$	0.01	10/ 15	μA_{max}
μP_{mon} Input Threshold Voltage		1.22	0.80/ 0.80	V_{min}
		1.22	2.00/ 2.00	V_{max}
μP Monitor Reset Oscillator Period	$V_{\mu P_{mon}} = 0V$ ($T_{window} = 0.82 R_t C_{mon}$)	50	45/ 30	ms_{min}
		50	55/ 70	ms_{max}
μP Monitor Reset Oscillator Pulse Width	$V_{\mu P_{mon}} = 0V$ ($RESET_{pw} = 2000 C_{mon}$)	1.0	0.7/ 0.4	ms_{min}
		1.0	1.3/ 2.10	ms_{max}
Minimum μP Monitor Input Pulse Width	⁽⁵⁾	2		μs

(3) Isolation refers to the ability of the specified output to remain within the tested limits when the other output is shorted to ground.

(4) Internal comparators detect when the main regulator output (V_{OUT}) changes from the measured output voltage (with $V_{IN} = 14V$) by the specified amount, ΔV_{OUT} High or ΔV_{OUT} Low, and set the Reset Error Flag low. The Reset Error Flag is held low until V_{OUT} returns to regulation. The Reset Error Flag is then allowed to go high again after a delay set by R_t and C_t . (see [Application Hints](#) section).

(5) This parameter is a measure of how short a pulse can be detected at the μP Monitor Input. This parameter is primarily influenced by the value of C_{mon} . (See [Application Hints](#) Section.)

Electrical Characteristics (continued)

$V_{IN} = 14V$, $I_{OUT} = 5\text{ mA}$, $C_{OUT} = 10\text{ }\mu\text{F}$, unless otherwise indicated. **Boldface** type refers to limits over the entire operating temperature range, $-40^{\circ}\text{C} \leq T_A \leq +125^{\circ}\text{C}$, all other limits are for $T_A = T_j = 25^{\circ}\text{C}$ ⁽¹⁾.

Parameter	Conditions	Typical	Limit (2)	Units
Reset Fall Time	$R_{rst} = 10k$, $V_{rst} = 5V$, $C_{rst} \leq 10\text{ pF}$	0.20	1.00/ 1.00	μs_{max}
Reset Rise Time	$R_{rst} = 10k$, $V_{rst} = 5V$, $C_{rst} \leq 10\text{ pF}$	0.60	1.00/ 1.50	μs_{max}
On/Off Switch Input Current (Pin 8)	$V_{ON} = 2.4V$	7.5	25/25	μA_{max}
	$V_{ON} = 0.4V$	0.01	10/10	μA_{max}
On/Off Switch Input Threshold Voltage		1.22	0.80/ 0.80	V_{min}
		1.22	2.00/ 2.00	V_{max}

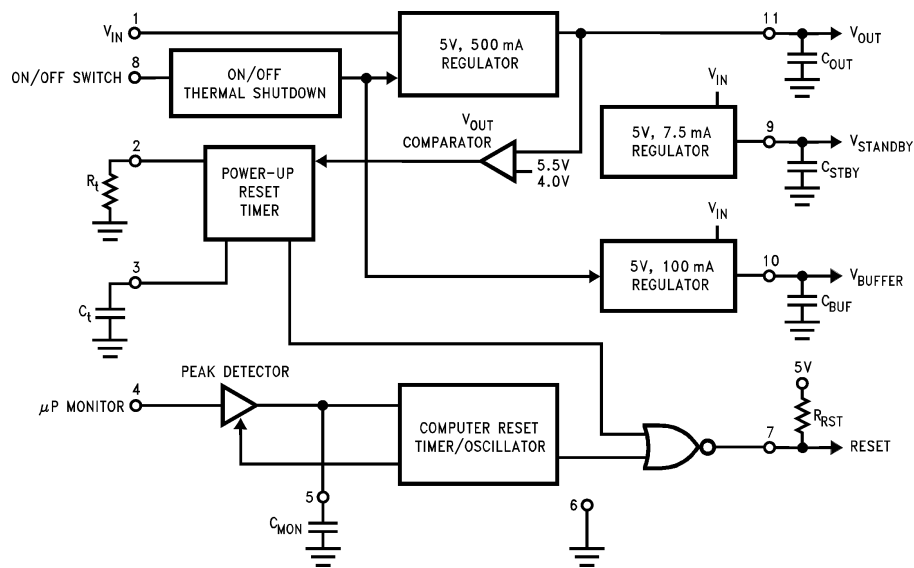
BLOCK DIAGRAM

Pin Descriptions

Pin No.	Pin Name	Comments
1	V_{IN}	Positive supply input voltage
2	R_t	Sets internal timing currents
3	C_t	Sets power-up reset delay timing
4	μP_{mon}	Microcomputer monitor input
5	C_{mon}	Sets μC monitor timing
6	Ground	Regulator ground
7	Reset	Reset error flag output
8	ON/OFF	Enables/disables high current regulators
9	$V_{standby}$	Standby regulator output (7.5 mA)
10	V_{buffer}	Buffer regulator output (100 mA)
11	V_{OUT}	Main regulator output (500 mA)

External Components

Component	Typical Value	Component Range	Comments
C_{IN}	1 μ F	0.47 μ F–10 μ F	Required if device is located far from power supply filter.
R_t	130k	24k–510k	Sets internal timing currents.
C_t	0.33 μ F	0.033 μ F–3.3 μ F	Sets power-up reset delay.
C_{tc}	0.01 μ F	0.001 μ F–0.1 μ F	Establishes time constant of AC coupled computer monitor.
R_{tc}	10k	1k–100k	Establishes time constant of AC coupled computer monitor. (See Application Hints section.)
C_{mon}	0.47 μ F	0.047 μ F–4.7 μ F	Sets time window for computer monitor. Also determines period and pulse width of computer malfunction reset. (See Application Hints section.)
R_{rst}	10k	5k–100k	Load for open collector reset output. Determined by computer reset input requirements.
C_{stby}	10 μ F	10 μ F–no bound	A 10 μ F is required for stability but larger values can be used to maintain regulation during transient conditions.
C_{buf}	10 μ F	10 μ F–no bound	A 10 μ F is required for stability but larger values can be used to maintain regulation during transient conditions.
C_{OUT}	10 μ F	10 μ F–no bound	A 10 μ F is required for stability but larger values can be used to maintain regulation during transient conditions.

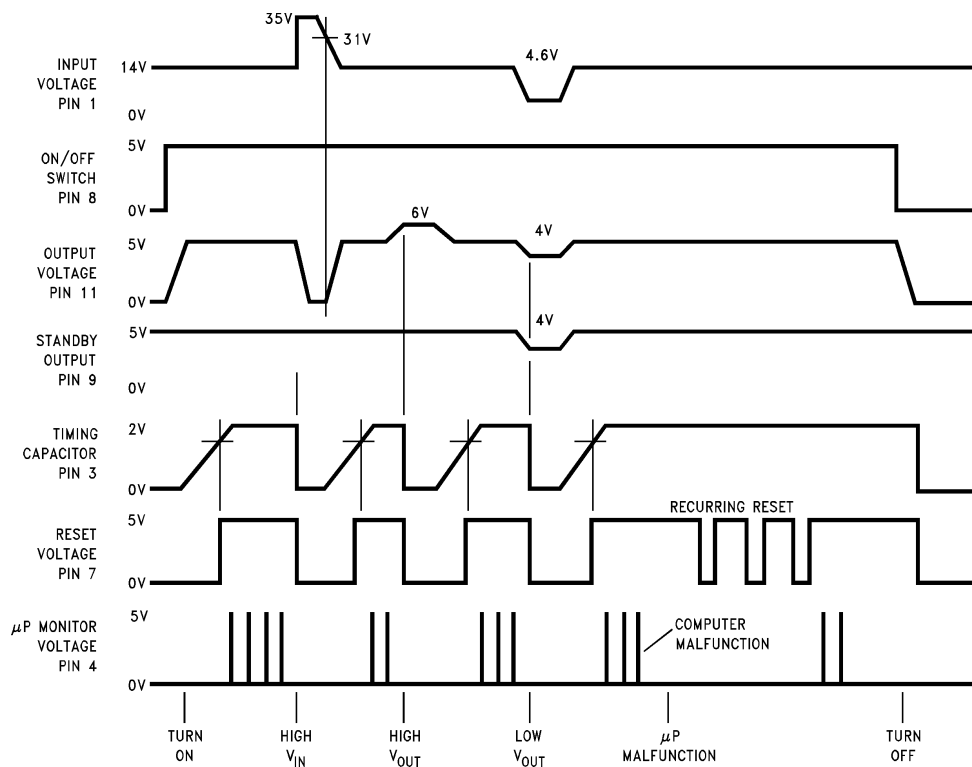
Typical Circuit Waveforms



Connection Diagram

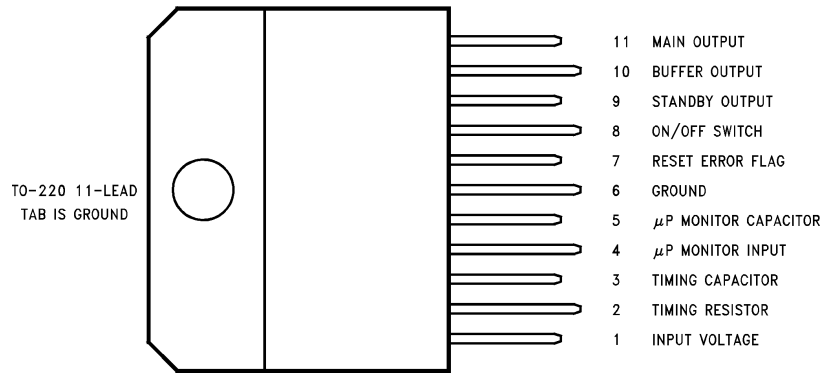

Figure 2. Package Number NDJ0011B

Typical Performance Characteristics

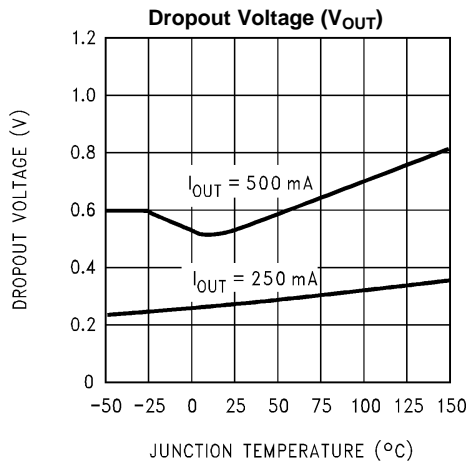

Figure 3.

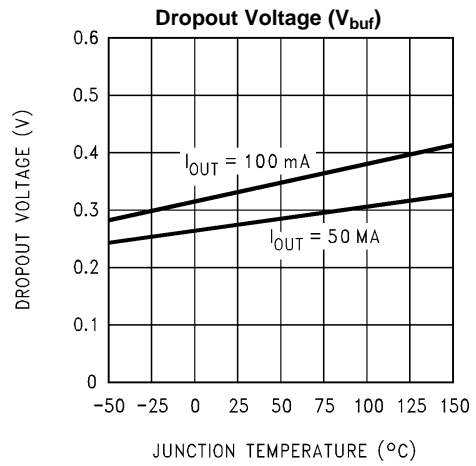

Figure 4.

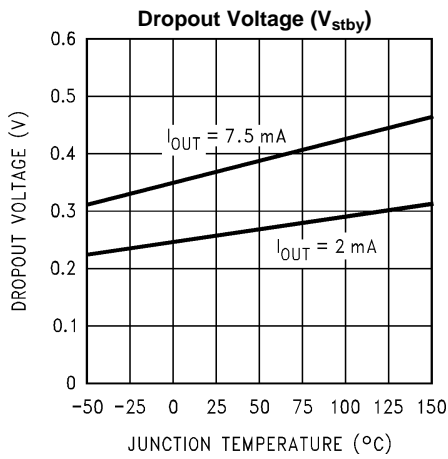

Figure 5.

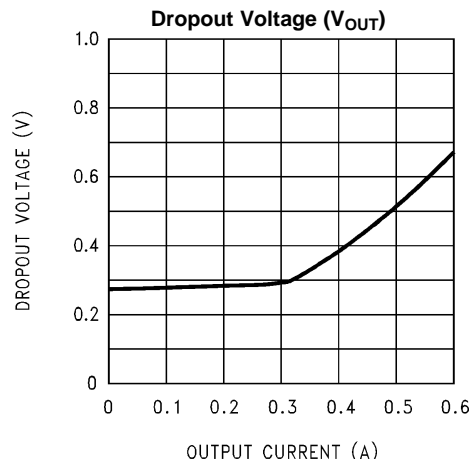

Figure 6.

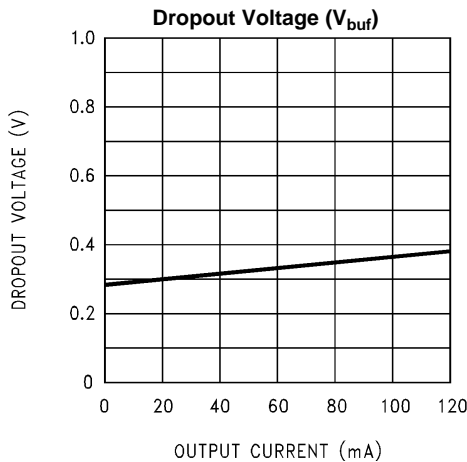

Figure 7.

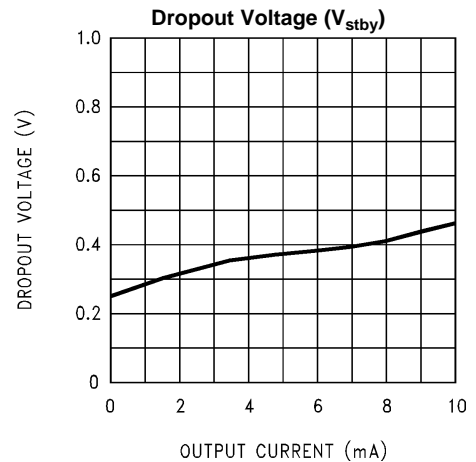

Figure 8.

Typical Performance Characteristics (continued)

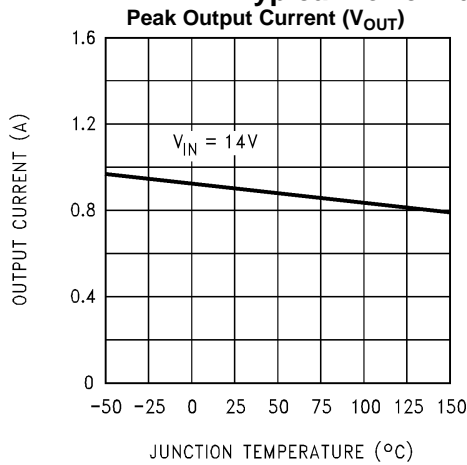

Figure 9.

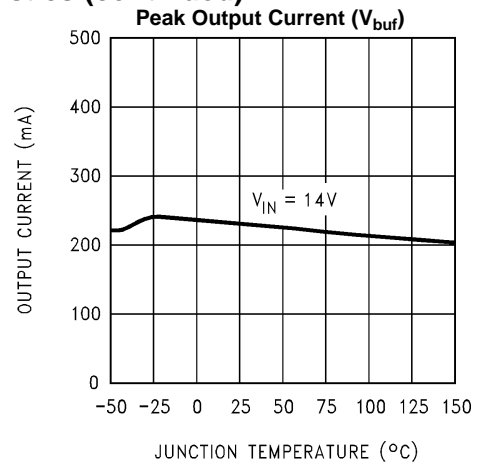

Figure 10.

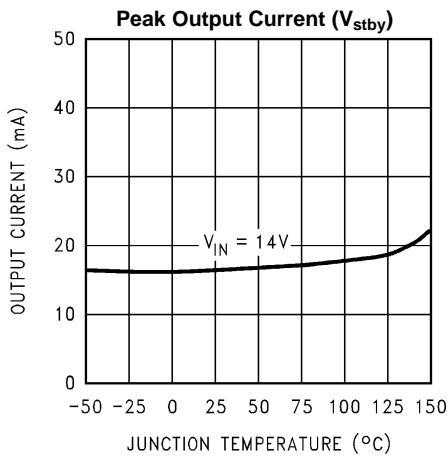

Figure 11.

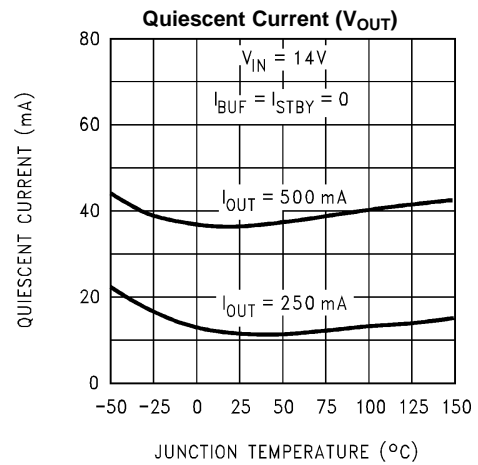

Figure 12.

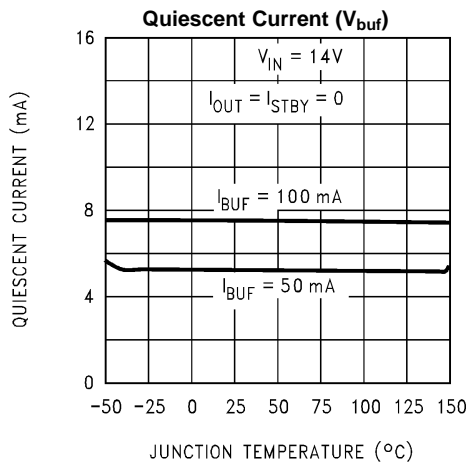

Figure 13.

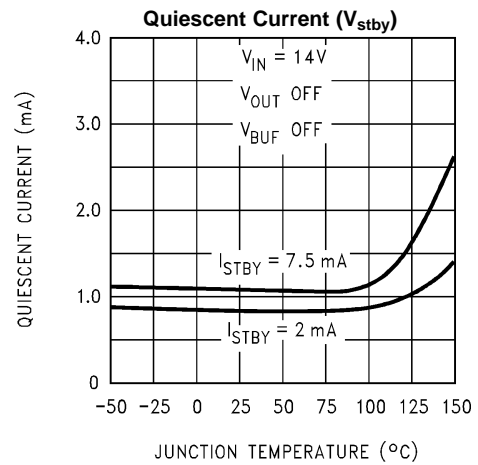

Figure 14.

Typical Performance Characteristics (continued)

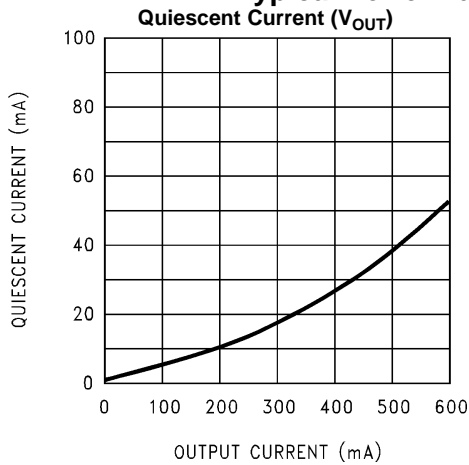

Figure 15.

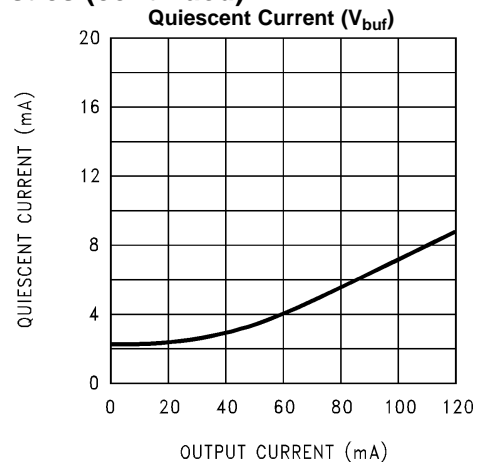

Figure 16.

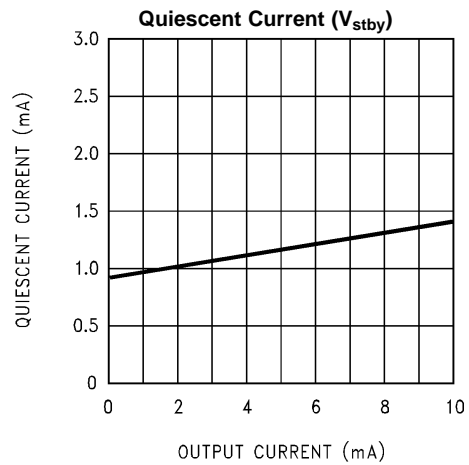

Figure 17.

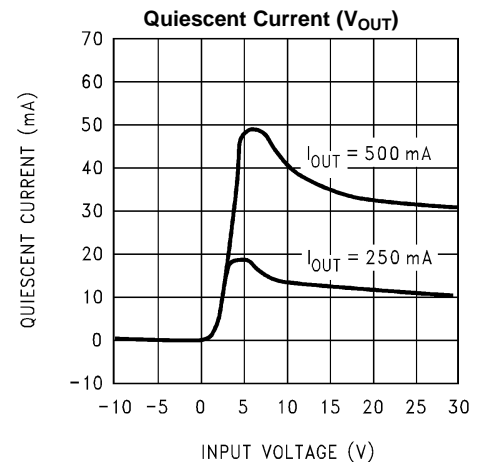

Figure 18.

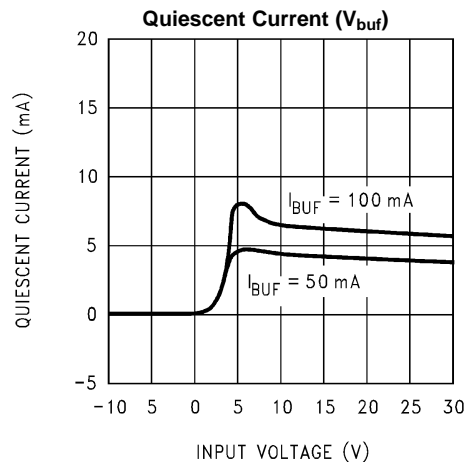

Figure 19.

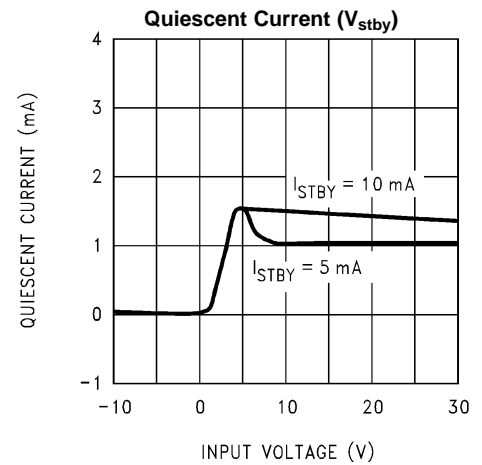

Figure 20.

Typical Performance Characteristics (continued)

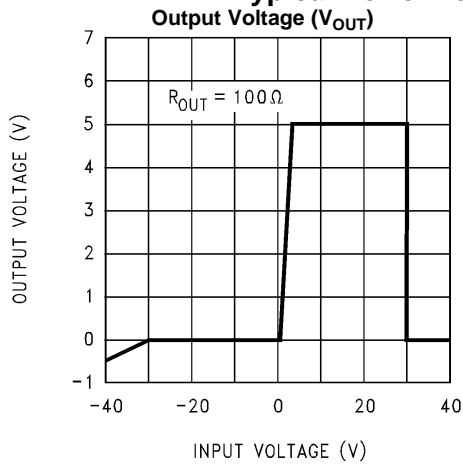

Figure 21.

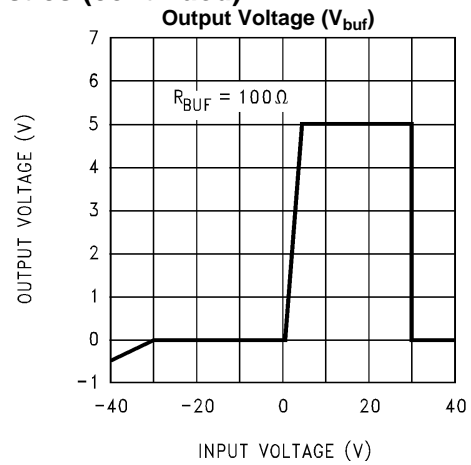

Figure 22.

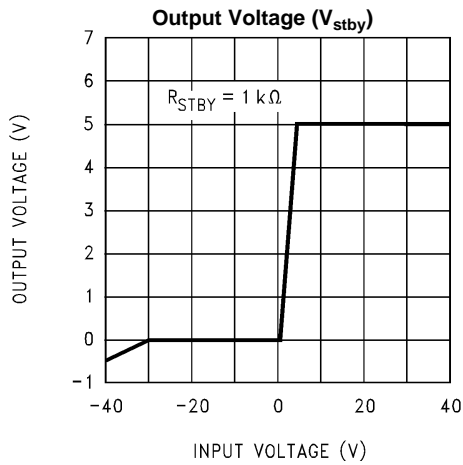

Figure 23.

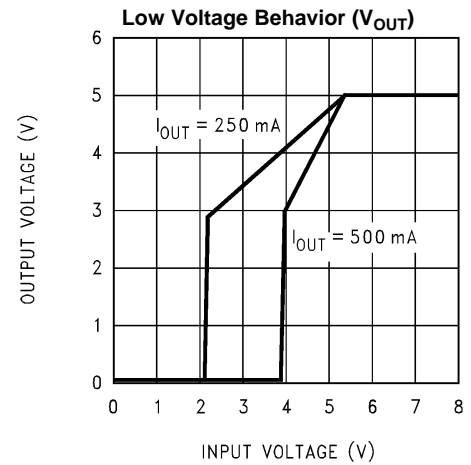

Figure 24.

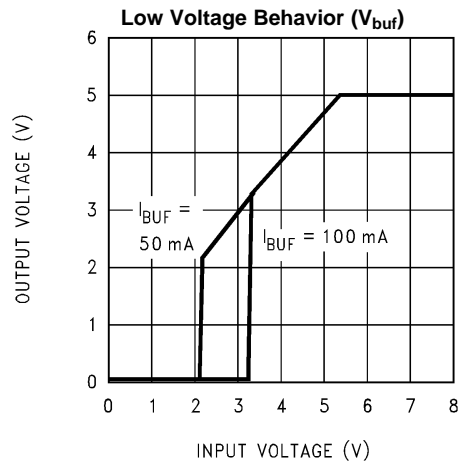

Figure 25.

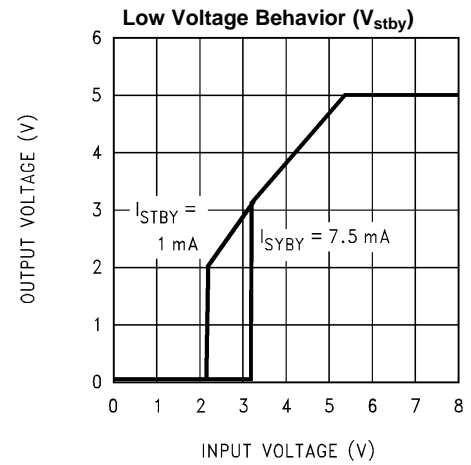

Figure 26.

Typical Performance Characteristics (continued)

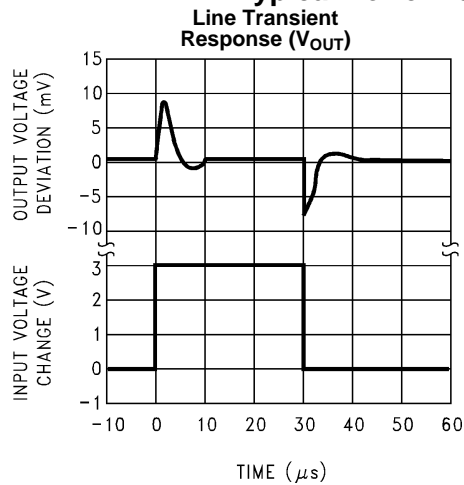

Figure 27.

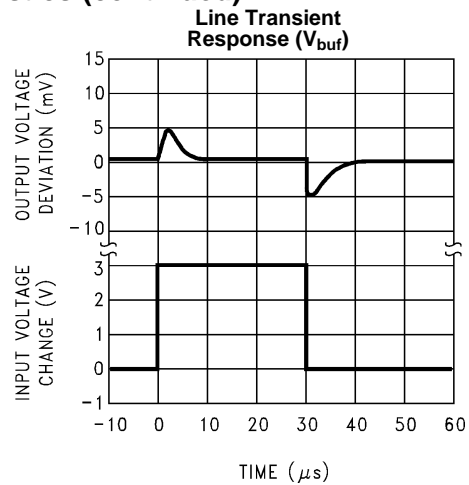

Figure 28.

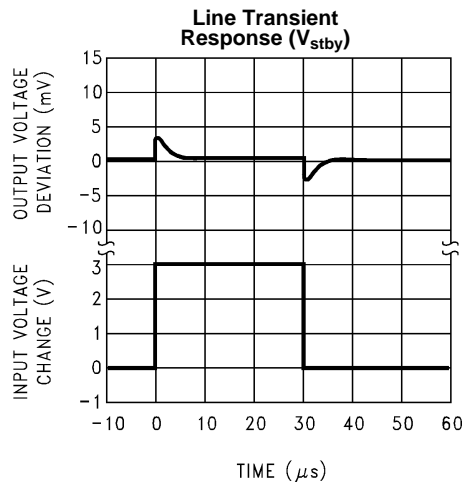

Figure 29.

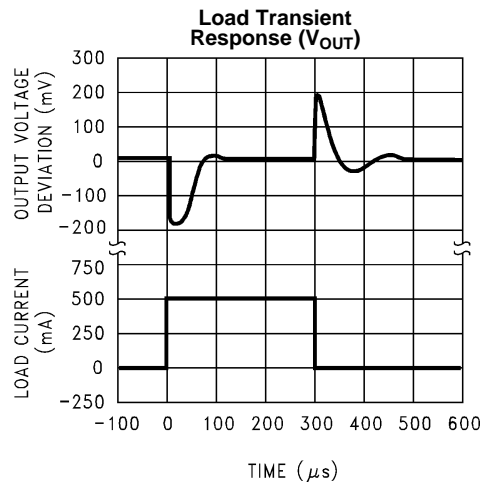

Figure 30.

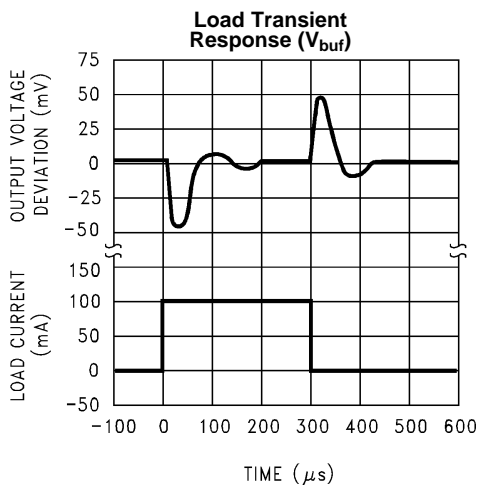

Figure 31.

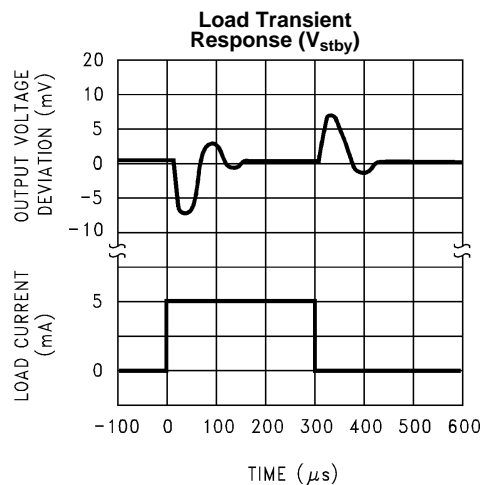

Figure 32.

Typical Performance Characteristics (continued)

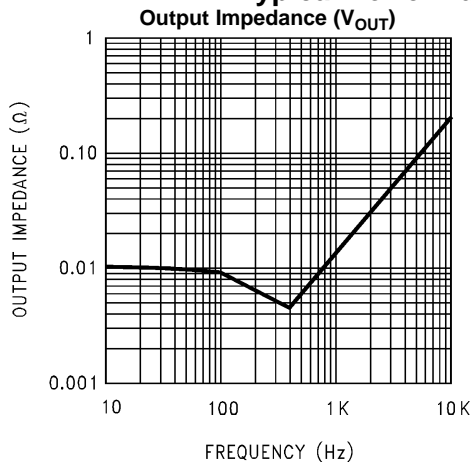

Figure 33.

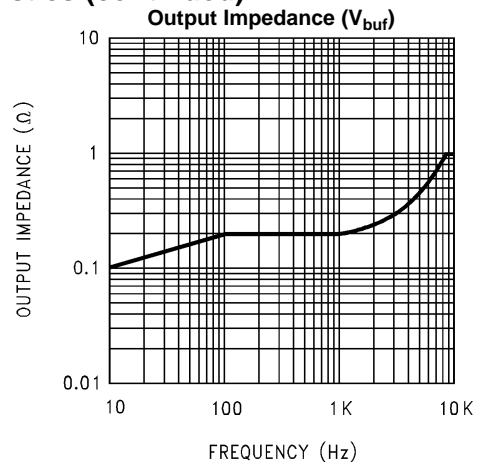

Figure 34.

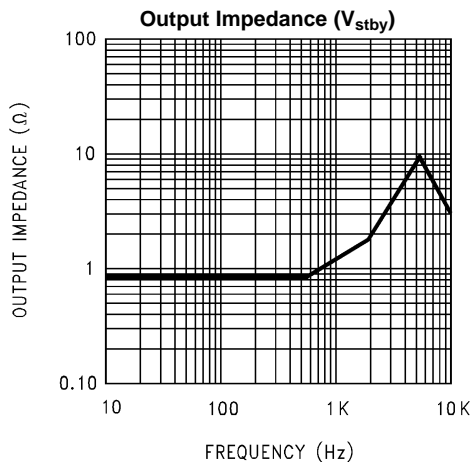

Figure 35.

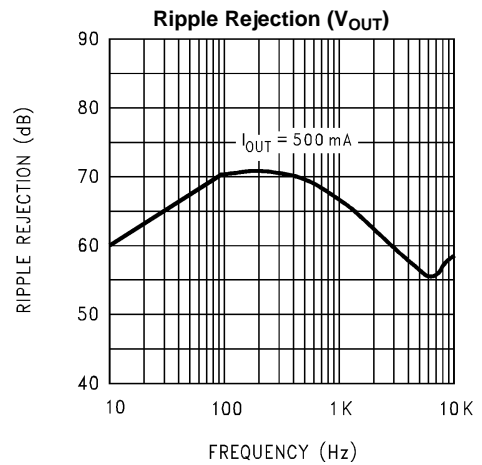

Figure 36.

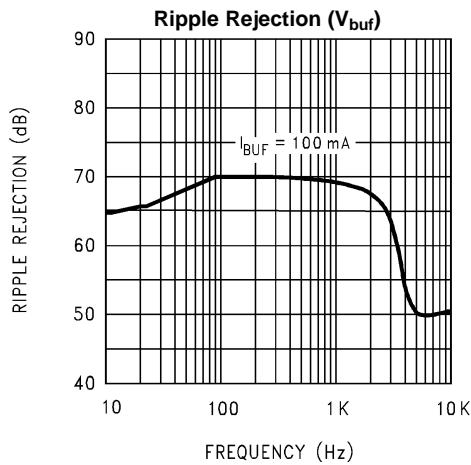

Figure 37.

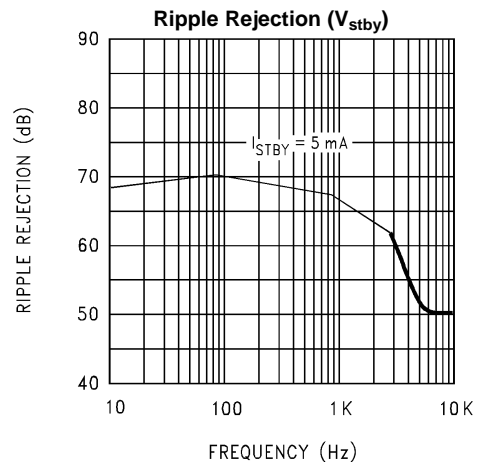

Figure 38.

Typical Performance Characteristics (continued)

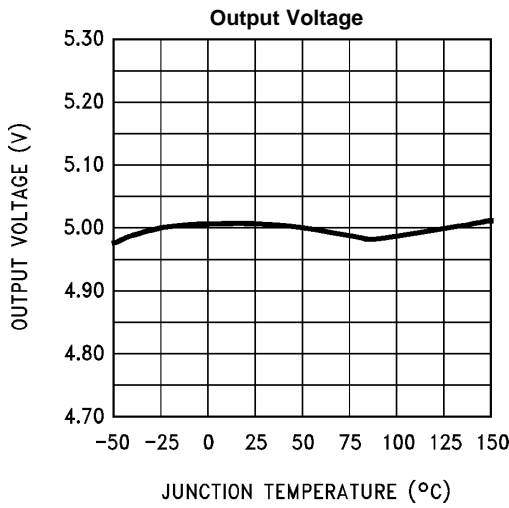

Figure 39.

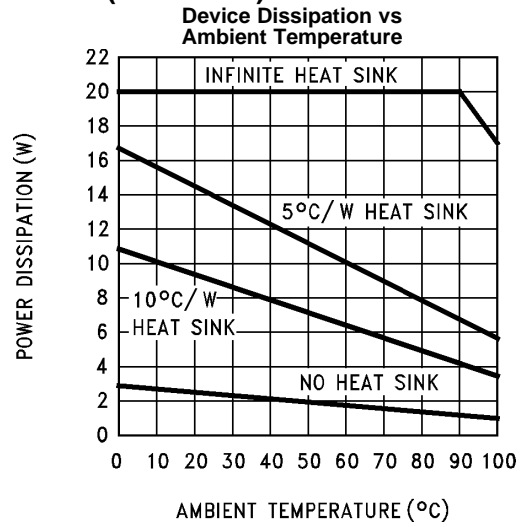

Figure 40.

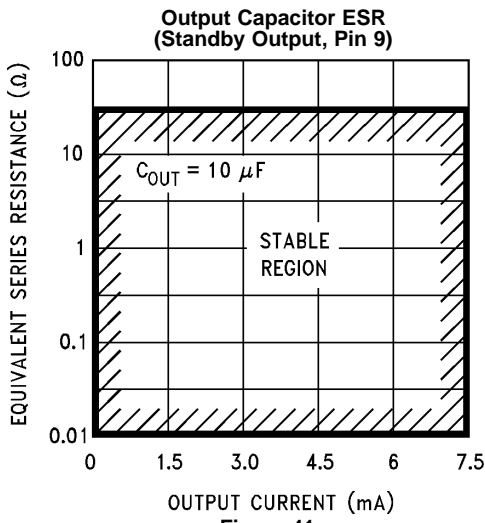

Figure 41.

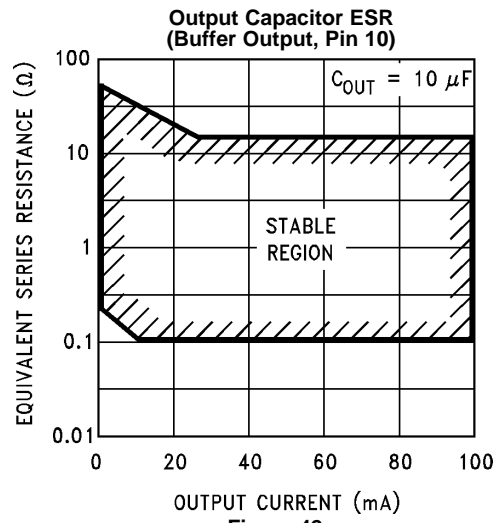

Figure 42.

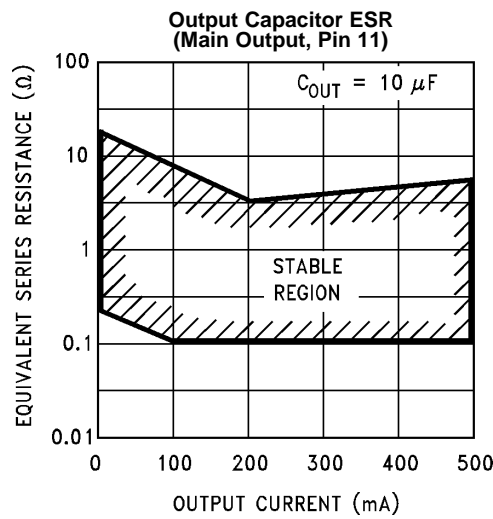

Figure 43.

APPLICATION HINTS

OUTPUT CAPACITORS

The LM2984 output capacitors are required for stability. Without them, the regulator outputs will oscillate, sometimes by many volts. Though the 10 μF shown are the minimum recommended values, actual size and type may vary depending upon the application load and temperature range. Capacitor effective series resistance (ESR) also affects the IC stability. Since ESR varies from one brand to the next, some bench work may be required to determine the minimum capacitor value to use in production. Worst case is usually determined at the minimum ambient temperature and the maximum load expected.

Output capacitors can be increased in size to any desired value above the minimum. One possible purpose of this would be to maintain the output voltages during brief conditions of negative input transients that might be characteristic of a particular system.

Capacitors must also be rated at all ambient temperatures expected in the system. Many aluminum type electrolytics will freeze at temperatures less than -30°C , reducing their effective capacitance to zero. To maintain regulator stability down to -40°C , capacitors rated at that temperature (such as tantalums) must be used.

Each output **must** be terminated by a capacitor, even if it is not used.

STANDBY OUTPUT

The standby output is intended for use in systems requiring standby memory circuits. While the high current regulator outputs are controlled with the ON/OFF pin described later, the standby output remains on under all conditions as long as sufficient input voltage is supplied to the IC. Thus, memory and other circuits powered by this output remain unaffected by positive line transients, thermal shutdown, etc.

The standby regulator circuit is designed so that the quiescent current to the IC is very low ($<1.5\text{ mA}$) when the other regulator outputs are off.

The capacitor on the output of this regulator can be increased without bound. This will help maintain the output voltage during negative input transients and will also help to reduce the noise on all three outputs. Because the other two track the standby output: therefore any noise reduction here will also reduce the other two noise voltages.

BUFFER OUTPUT

The buffer output is designed to drive peripheral sensor circuitry in a μP system. It will track the standby and main regulator within a few millivolts in normal operation. Therefore, a peripheral sensor can be powered off this supply and have the same operating voltage as the μP system. This is important if a ratiometric sensor system is being used.

The buffer output can be short circuited while the other two outputs are in normal operation. This protects the μP system from disruption of power when a sensor wire, etc. is temporarily shorted to ground, i.e. only the sensor signal would be interrupted, while the μP and memory circuits would remain operational.

The buffer output is similar to the main output in that it is controlled by the ON/OFF switch in order to save power in the standby mode. It is also fault protected against overvoltage and thermal overload. If the input voltage rises above approximately 30V (e.g. load dump), this output will automatically shut down. This protects the internal circuitry and enables the IC to survive higher voltage transients than would otherwise be expected. Thermal shutdown is necessary since this output is one of the dominant sources of power dissipation in the IC.

MAIN OUTPUT

The main output is designed to power relatively large loads, i.e. approximately 500 mA. It is therefore also protected against overvoltage and thermal overload.

This output will track the other two within a few millivolts in normal operation. It can therefore be used as a reference voltage for any signal derived from circuitry powered off the standby or buffer outputs. This is important in a ratiometric sensor system or any system requiring accurate matching of power supply voltages.

ON/OFF SWITCH

The ON/OFF switch controls the main output and the buffer output. The threshold voltage is compatible with most logic families and has about 20 mV of hysteresis to insure “clean” switching from the standby mode to the active mode and vice versa. This pin can be tied to the input voltage through a 10 kΩ resistor if the regulator is to be powered continuously.

POWER DOWN OVERRIDE

Another possible approach is to use a diode in series with the ON/OFF signal and another in series with the main output in order to maintain power for some period of time after the ON/OFF signal has been removed (see [Figure 44](#)). When the ON/OFF switch is initially pulled high through diode D1, the main output will turn on and supply power through diode D2 to the ON/OFF switch effectively latching the main output. An open collector transistor Q1 is connected to the ON/OFF pin along with the two diodes and forces the regulators off after a period of time determined by the μP . In this way, the μP can override a power down command and store data, do housekeeping, etc. before reverting back to the standby mode.

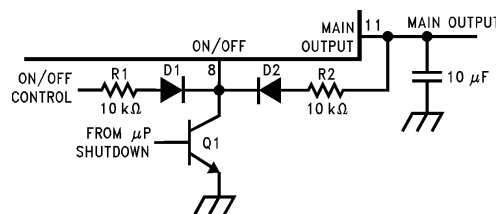

Figure 44. Power Down Override

RESET OUTPUT

This output is an open collector NPN transistor which is forced low whenever an error condition is present at the main output or when a μP error is sensed (see [\$\mu\text{P}\$ MONITOR RESET](#) section). If the main output voltage drops by 350 mV or rises out of regulation by 600 mV typically, the RESET output is forced low and held low for a period of time set by two external components, R_t and C_t . There is a slight amount of hysteresis in these two threshold voltages so that the RESET output has a fast rise and fall time compatible with the requirements of most μP RESET inputs.

DELAYED RESET

Resistor R_t and capacitor C_t set the period of time that the RESET output is held low after a main output error condition has been sensed. The delay is given by the formula:

$$T_{\text{dly}} = 1.2 R_t C_t \text{ (seconds)} \quad (1)$$

The delayed RESET will be initiated any time the main output is out of regulation, i.e. during power-up, short circuit, overvoltage, low line, thermal shutdown or power-down. The μP is therefore RESET whenever the output voltage is out of regulation. (It is important to note that a RESET is only initiated when the main output is in error. The buffer and standby outputs are not directly monitored for error conditions.)

μP MONITOR RESET

There are two distinct and independent error monitoring systems in the LM2984. The one described above monitors the main regulator output and initiates a delayed RESET whenever this output is in error. The other error monitoring system is the μP watchdog. These two systems are OR'd together internally and both force the RESET output low when either type of error occurs.

This watchdog circuitry continuously monitors a pin on the μP that generates a positive going pulse during normal operation. The period of this pulse is typically on the order of milliseconds and the pulse width is typically on the order of 10's of microseconds. If this pulse ever disappears, the watchdog circuitry will time out and a RESET low will be sent to the μP . The time out period is determined by two external components, R_t and C_{mon} , according to the formula:

$$T_{\text{window}} = 0.82 R_t C_{\text{mon}} \text{ (seconds)} \quad (2)$$

The width of the RESET pulse is set by C_{mon} and an internal resistor according to the following:

$$RESET_{pw} = 2000 C_{mon} \text{ (seconds)} \quad (3)$$

A square wave signal can also be monitored for errors by filtering the C_{mon} input such that only the positive edges of the signal are detected. Figure 45 is a schematic diagram of a typical circuit used to differentiate the input signal. Resistor R_{tc} and capacitor C_{tc} pass only the rising edge of the square wave and create a short positive pulse suitable for the μP monitor input. If the incoming signal continues in a high state or in a low state for too long a period of time, a RESET low will be generated.

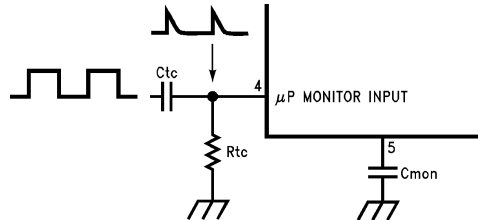

Figure 45. Monitoring Square Wave μP Signals

The threshold voltage and input characteristics of this pin are compatible with nearly all logic families.

There is a limit on the width of a pulse that can be reliably detected by the watchdog circuit. This is due to the output resistance of the transistor which discharges C_{mon} when a high state is detected at the input. The minimum detectable pulse width can be determined by the following formula:

$$PW_{min} = 20 C_{mon} \text{ (seconds)} \quad (4)$$

Equivalent Schematic Diagram

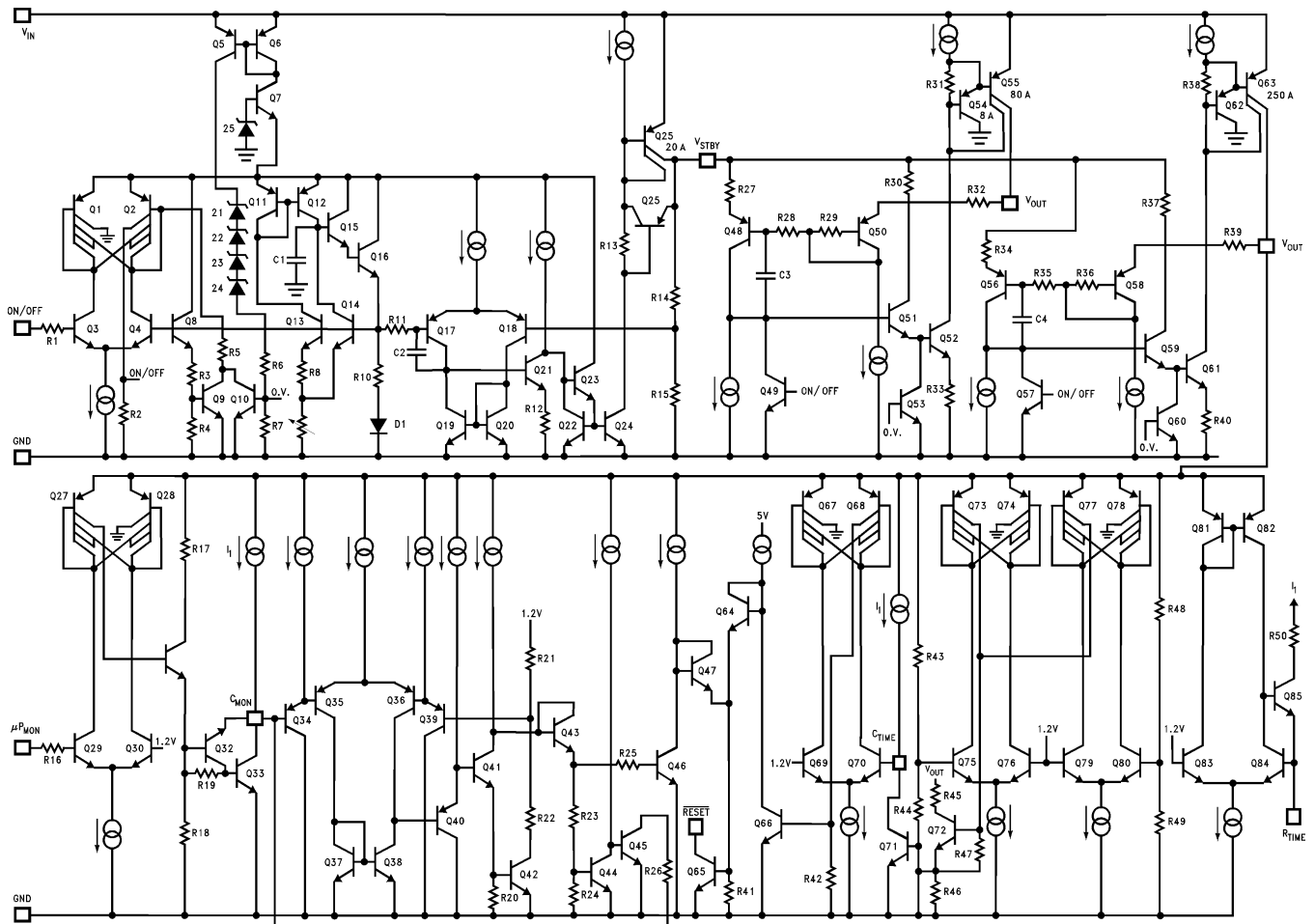

REVISION HISTORY

Changes from Revision B (March 2013) to Revision C	Page
<hr/> <ul style="list-style-type: none">• Changed layout of National Data Sheet to TI format	<hr/> 18

PACKAGING INFORMATION

Orderable Device	Status (1)	Package Type	Package Drawing	Pins	Package Qty	Eco Plan (2)	Lead/Ball Finish	MSL Peak Temp (3)	Op Temp (°C)	Top-Side Markings (4)	Samples
LM2984T	ACTIVE	TO-220	NDJ	11	20	TBD	Call TI	Call TI	-40 to 125	LM2984T	Samples

(1) The marketing status values are defined as follows:

ACTIVE: Product device recommended for new designs.

LIFEBUY: TI has announced that the device will be discontinued, and a lifetime-buy period is in effect.

NRND: Not recommended for new designs. Device is in production to support existing customers, but TI does not recommend using this part in a new design.

PREVIEW: Device has been announced but is not in production. Samples may or may not be available.

OBSOLETE: TI has discontinued the production of the device.

(2) Eco Plan - The planned eco-friendly classification: Pb-Free (RoHS), Pb-Free (RoHS Exempt), or Green (RoHS & no Sb/Br) - please check <http://www.ti.com/productcontent> for the latest availability information and additional product content details.

TBD: The Pb-Free/Green conversion plan has not been defined.

Pb-Free (RoHS): TI's terms "Lead-Free" or "Pb-Free" mean semiconductor products that are compatible with the current RoHS requirements for all 6 substances, including the requirement that lead not exceed 0.1% by weight in homogeneous materials. Where designed to be soldered at high temperatures, TI Pb-Free products are suitable for use in specified lead-free processes.

Pb-Free (RoHS Exempt): This component has a RoHS exemption for either 1) lead-based flip-chip solder bumps used between the die and package, or 2) lead-based die adhesive used between the die and leadframe. The component is otherwise considered Pb-Free (RoHS compatible) as defined above.

Green (RoHS & no Sb/Br): TI defines "Green" to mean Pb-Free (RoHS compatible), and free of Bromine (Br) and Antimony (Sb) based flame retardants (Br or Sb do not exceed 0.1% by weight in homogeneous material)

(3) MSL, Peak Temp. -- The Moisture Sensitivity Level rating according to the JEDEC industry standard classifications, and peak solder temperature.

(4) Multiple Top-Side Markings will be inside parentheses. Only one Top-Side Marking contained in parentheses and separated by a "~" will appear on a device. If a line is indented then it is a continuation of the previous line and the two combined represent the entire Top-Side Marking for that device.

Important Information and Disclaimer: The information provided on this page represents TI's knowledge and belief as of the date that it is provided. TI bases its knowledge and belief on information provided by third parties, and makes no representation or warranty as to the accuracy of such information. Efforts are underway to better integrate information from third parties. TI has taken and continues to take reasonable steps to provide representative and accurate information but may not have conducted destructive testing or chemical analysis on incoming materials and chemicals. TI and TI suppliers consider certain information to be proprietary, and thus CAS numbers and other limited information may not be available for release.

In no event shall TI's liability arising out of such information exceed the total purchase price of the TI part(s) at issue in this document sold by TI to Customer on an annual basis.

NDJ0011B

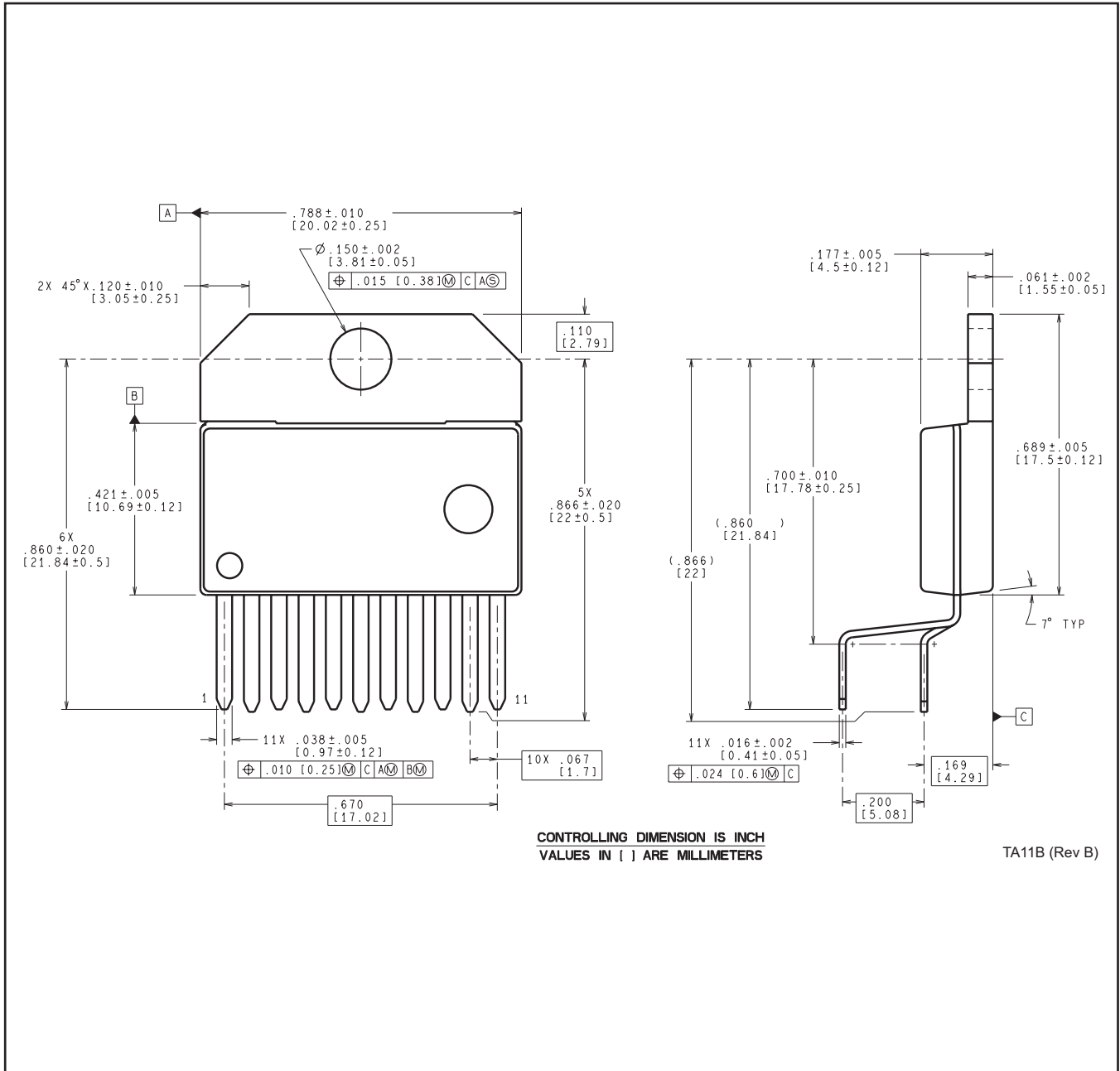

IMPORTANT NOTICE

Texas Instruments Incorporated and its subsidiaries (TI) reserve the right to make corrections, enhancements, improvements and other changes to its semiconductor products and services per JESD46, latest issue, and to discontinue any product or service per JESD48, latest issue. Buyers should obtain the latest relevant information before placing orders and should verify that such information is current and complete. All semiconductor products (also referred to herein as "components") are sold subject to TI's terms and conditions of sale supplied at the time of order acknowledgment.

TI warrants performance of its components to the specifications applicable at the time of sale, in accordance with the warranty in TI's terms and conditions of sale of semiconductor products. Testing and other quality control techniques are used to the extent TI deems necessary to support this warranty. Except where mandated by applicable law, testing of all parameters of each component is not necessarily performed.

TI assumes no liability for applications assistance or the design of Buyers' products. Buyers are responsible for their products and applications using TI components. To minimize the risks associated with Buyers' products and applications, Buyers should provide adequate design and operating safeguards.

TI does not warrant or represent that any license, either express or implied, is granted under any patent right, copyright, mask work right, or other intellectual property right relating to any combination, machine, or process in which TI components or services are used. Information published by TI regarding third-party products or services does not constitute a license to use such products or services or a warranty or endorsement thereof. Use of such information may require a license from a third party under the patents or other intellectual property of the third party, or a license from TI under the patents or other intellectual property of TI.

Reproduction of significant portions of TI information in TI data books or data sheets is permissible only if reproduction is without alteration and is accompanied by all associated warranties, conditions, limitations, and notices. TI is not responsible or liable for such altered documentation. Information of third parties may be subject to additional restrictions.

Resale of TI components or services with statements different from or beyond the parameters stated by TI for that component or service voids all express and any implied warranties for the associated TI component or service and is an unfair and deceptive business practice. TI is not responsible or liable for any such statements.

Buyer acknowledges and agrees that it is solely responsible for compliance with all legal, regulatory and safety-related requirements concerning its products, and any use of TI components in its applications, notwithstanding any applications-related information or support that may be provided by TI. Buyer represents and agrees that it has all the necessary expertise to create and implement safeguards which anticipate dangerous consequences of failures, monitor failures and their consequences, lessen the likelihood of failures that might cause harm and take appropriate remedial actions. Buyer will fully indemnify TI and its representatives against any damages arising out of the use of any TI components in safety-critical applications.

In some cases, TI components may be promoted specifically to facilitate safety-related applications. With such components, TI's goal is to help enable customers to design and create their own end-product solutions that meet applicable functional safety standards and requirements. Nonetheless, such components are subject to these terms.

No TI components are authorized for use in FDA Class III (or similar life-critical medical equipment) unless authorized officers of the parties have executed a special agreement specifically governing such use.

Only those TI components which TI has specifically designated as military grade or "enhanced plastic" are designed and intended for use in military/aerospace applications or environments. Buyer acknowledges and agrees that any military or aerospace use of TI components which have **not** been so designated is solely at the Buyer's risk, and that Buyer is solely responsible for compliance with all legal and regulatory requirements in connection with such use.

TI has specifically designated certain components as meeting ISO/TS16949 requirements, mainly for automotive use. In any case of use of non-designated products, TI will not be responsible for any failure to meet ISO/TS16949.

Products

Audio	www.ti.com/audio
Amplifiers	amplifier.ti.com
Data Converters	dataconverter.ti.com
DLP® Products	www.dlp.com
DSP	dsp.ti.com
Clocks and Timers	www.ti.com/clocks
Interface	interface.ti.com
Logic	logic.ti.com
Power Mgmt	power.ti.com
Microcontrollers	microcontroller.ti.com
RFID	www.ti-rfid.com
OMAP Applications Processors	www.ti.com/omap
Wireless Connectivity	www.ti.com/wirelessconnectivity

Applications

Automotive and Transportation	www.ti.com/automotive
Communications and Telecom	www.ti.com/communications
Computers and Peripherals	www.ti.com/computers
Consumer Electronics	www.ti.com/consumer-apps
Energy and Lighting	www.ti.com/energy
Industrial	www.ti.com/industrial
Medical	www.ti.com/medical
Security	www.ti.com/security
Space, Avionics and Defense	www.ti.com/space-avionics-defense
Video and Imaging	www.ti.com/video

TI E2E Community

e2e.ti.com

Looking for pricing, stock, or lifecycle information?

Click below to explore more details on WIN SOURCE:

 [View LM2984T/NOPB on WIN SOURCE](#)

 [Texas Instruments](#) Information

Optimize Your Supply Chain with WIN SOURCE Solutions

-  Global Sourcing Solution
-  Obsolete Management
-  Cost Control Management
-  Shortage Management
-  Alternative Solution
-  Excess Inventory Management