



THE DATASHEET OF LM2796TL/NOPB



LM2796 Dual-Display White LED Driver with 3/2x Switched Capacitor Boost

Check for Samples: [LM2796](#)

FEATURES

- Drives up to 7 LEDs with up to 20mA Each
- LEDs Controlled in 2 Distinct Groups, for Backlighting 2 Displays (Main LCD and Sub-LCD)
- Excellent Current and Brightness Matching
- High-Efficiency 3/2x Charge Pump
- Extended Li-Ion Input: 2.7V to 5.5V
- PWM Brightness Control: 100Hz - 1kHz
- 18-bump Thin DSBGA Package: (2.1mm x 2.4mm x 0.6mm)

APPLICATIONS

- Mobile Phone Display Lighting
- Mobile Phone Keypad Lighting
- PDAs
- General LED Lighting

DESCRIPTION

The LM2796 is a charge-pump based white-LED driver that is ideal for mobile phone display backlighting. It can drive up to 7 LEDs in parallel with up to 20mA through each LED. Regulated internal current sources deliver excellent current and brightness matching in all LEDs. The LED-driver current sources are split into two independently controlled groups. The primary group (4 LEDs) can be used to backlight the main phone display. The second group (3 LEDs) can be used to backlight a secondary display or to provide other lighting features (keypad LEDs, for example). Brightness of the two groups can be adjusted independently with pulse-width modulated (PWM) digital signals.

The LM2796 works off an extended Li-Ion input voltage range (2.7V to 5.5V). Voltage boost is achieved with a high-efficiency 3/2x-gain charge pump.

The LM2796 is available in TI's chip-scale 18-bump DSBGA package.

Typical Application Circuit

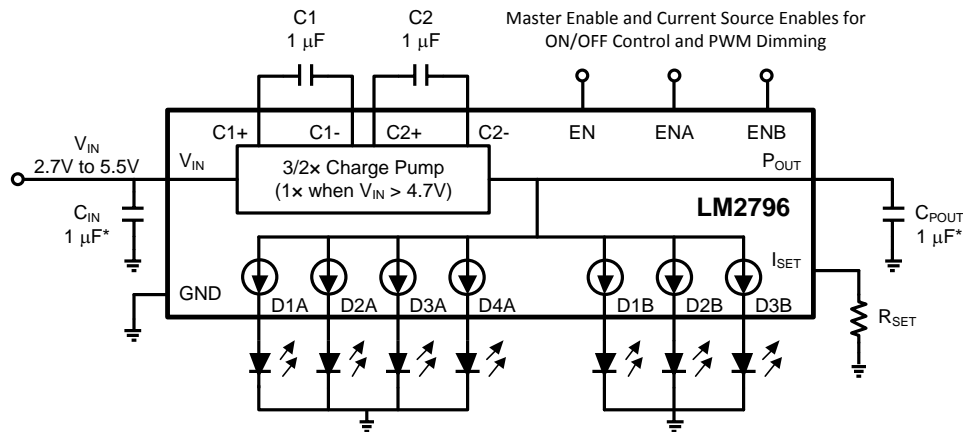

Capacitors: TDK C1608X5R1A105K, or equivalent

*If total LED current is above 80 mA, as can occur when all 7 outputs are ON simultaneously, 2.2 µF capacitors are recommended for C_{IN} and C_{POUT}.



Please be aware that an important notice concerning availability, standard warranty, and use in critical applications of Texas Instruments semiconductor products and disclaimers thereto appears at the end of this data sheet.

All trademarks are the property of their respective owners.

Connection Diagram

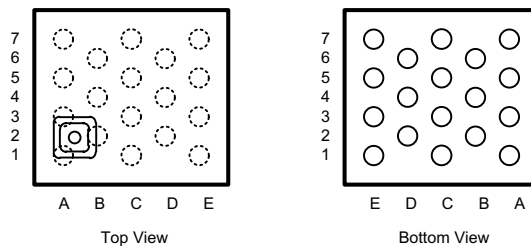

Figure 1. 18-Bump Thin DSBGA Package, Large Bump Package Number YZR0018

PIN DESCRIPTION

Pin #s	Pin Names	Pin Descriptions
C1	V_{IN}	Input voltage. Input range: 2.7V to 5.5V.
D2	GND	Ground
A3	P_{OUT}	Charge pump output. Approximately $1.5 \times V_{IN}$
A1, B2, A5, E1	C1+, C1-, C2+, C2-	Flying capacitor connections.
A7	EN	Enable pin. Logic input. High = normal operation, Low = shutdown (charge pump and all current sources OFF).
D6, E5, D4, E3	D1A, D2A, D3A, D4A	LED Outputs - Group A
C5, B4, C3	D1B, D2B, D3B	LED Outputs - Group B
B6	EN-A	Enable for Group-A LEDs (current outputs). Logic input. High = Group-A LEDs ON. Low = Group A LEDs OFF. Pulsing this pin with a PWM signal (100Hz-1kHz) can be used to dim LEDs.
E7	EN-B	Enable for Group-B LEDs (current outputs). Logic input. High = Group-B LEDs ON. Low = Group B LEDs OFF. Pulsing this pin with a PWM signal (100Hz-1kHz) can be used to dim LEDs.
C7	I_{SET}	Placing a resistor (R_{SET}) between this pin and GND sets the LED current for all LEDs. LED Current = $100 \times (1.25V \div R_{SET})$.



These devices have limited built-in ESD protection. The leads should be shorted together or the device placed in conductive foam during storage or handling to prevent electrostatic damage to the MOS gates.

ABSOLUTE MAXIMUM RATINGS⁽¹⁾⁽²⁾⁽³⁾

V_{IN} pin voltage		-0.3V to 7.1V
EN, ENA, ENB pin voltages		-0.3V to $(V_{IN}+0.3V)$ / 5.6V max
Continuous Power Dissipation ⁽⁴⁾		Internally Limited
Junction Temperature (T_{J-MAX})		150°C
Storage Temperature Range		-65°C to +150° C
Maximum Lead Temperature (Soldering, 10 sec.)		265°C
ESD Rating ⁽⁵⁾	Human Body Model	2.0kV
	Machine Model	200V

- (1) Absolute Maximum Ratings indicate limits beyond which damage to the component may occur. Operating Ratings are conditions under which operation of the device is specified. Operating Ratings do not imply specified performance limits. For specified performance limits and associated test conditions, see the Electrical Characteristics tables.
- (2) All voltages are with respect to the potential at the GND pin.
- (3) If Military/Aerospace specified devices are required, please contact the Texas Instruments Sales Office/ Distributors for availability and specifications.
- (4) Internal thermal shutdown circuitry protects the device from permanent damage. Thermal shutdown engages at $T_J = 160^\circ\text{C}$ (typ.) and disengages at $T_J = 120^\circ\text{C}$ (typ.). The thermal shutdown function is specified by design.
- (5) The Human body model is a 100pF capacitor discharged through a 1.5k resistor into each pin. The machine model is a 200pF capacitor discharged directly into each pin. MIL-STD-883 3015.7

OPERATING RATING⁽¹⁾⁽²⁾

Input Voltage Range		2.7V to 5.5V
Junction Temperature (T_J) Range		-30°C to +125°C
Ambient Temperature (T_A) Range ⁽³⁾		-30°C to +85°C

- (1) Absolute Maximum Ratings indicate limits beyond which damage to the component may occur. Operating Ratings are conditions under which operation of the device is specified. Operating Ratings do not imply specified performance limits. For specified performance limits and associated test conditions, see the Electrical Characteristics tables.
- (2) All voltages are with respect to the potential at the GND pin.
- (3) In applications where high power dissipation and/or poor package thermal resistance is present, the maximum ambient temperature may have to be derated. Maximum ambient temperature (T_{A-MAX}) is dependent on the maximum operating junction temperature ($T_{J-MAX-OP} = 125^\circ\text{C}$), the maximum power dissipation of the device in the application (P_{D-MAX}), and the junction-to ambient thermal resistance of the part/package in the application (θ_{JA}), as given by the following equation: $T_{A-MAX} = T_{J-MAX-OP} - (\theta_{JA} \times P_{D-MAX})$.

THERMAL PROPERTIES

Junction-to-Ambient Thermal Resistance (θ_{JA}) ⁽¹⁾		100°C/W
-------------------------------------------------------------------------	--	---------

- (1) Junction-to-ambient thermal resistance is highly dependent on application and board layout. In applications where high maximum power dissipation exists, special care must be paid to thermal dissipation issues in board design.

ELECTRICAL CHARACTERISTICS⁽¹⁾⁽²⁾

Limits in standard typeface and typical values apply for $T_J = 25^\circ\text{C}$. Limits in **boldface** type apply over the full operating junction temperature range ($-30^\circ\text{C} \leq T_J \leq +85^\circ\text{C}$). Unless otherwise specified: $V_{IN} = 3.6\text{V}$; $V_{DXX} = 3.6\text{V}$; $V(EN) = 2.0\text{V}$; Group A and Group B LEDs not ON simultaneously⁽³⁾ ($EN_A = V_{IN}$ and $EN_B = \text{GND}$, or $EN_A = \text{GND}$ and $EN_B = V_{IN}$); $R_{SET} = 8.35\text{k}\Omega$; C_{IN} , C_1 , C_2 , and $C_{P_OUT} = 1\mu\text{F}$ ⁽⁴⁾.

Symbol	Parameter	Condition	Min	Typ	Max	Units
I_{DXX}	Output Current Regulation	$3.0\text{V} \leq V_{IN} \leq 4.2\text{V}$, and $V_{IN} = 5.5\text{V}$ $2.5\text{V} \leq V_{DXX} \leq 3.8\text{V}$; $R_{SET} = 8.35\text{k}\Omega$	13.8 (-8%)	15	16.2 (+8%)	mA (%)
		$3.0\text{V} \leq V_{IN} \leq 5.5\text{V}$; $2.5\text{V} \leq V_{DXX} \leq 3.6\text{V}$; $R_{SET} = 6.25\text{k}\Omega$		20		mA
		$3.0\text{V} \leq V_{IN} \leq 5.5\text{V}$; $2.5\text{V} \leq V_{DXX} \leq 3.9\text{V}$; $R_{SET} = 12.5\text{k}\Omega$		10		mA
		$2.7\text{V} \leq V_{IN} \leq 3.0\text{V}$; $2.5\text{V} \leq V_{DXX} \leq 3.3\text{V}$; $R_{SET} = 8.35\text{k}\Omega$		15		mA
		EN _A and EN _B ON (all 7 I_{DXX} outputs active), $V_{IN} = 3.0\text{V}$, $C_{IN} = C_{OUT} = 2.2\mu\text{F}$		15		mA
$I_{DXX-MATCH}$	Current Matching Between Any Two Group A Outputs or Group B Outputs	$V_{IN} = 3.0\text{V}$ ⁽⁵⁾		1		%
I_Q	Quiescent Supply Current	$2.7\text{V} \leq V_{IN} \leq 4.2\text{V}$; No Load Current, EN = ON, EN _A = EN _B = OFF		3.5	6	mA
I_{SD}	Shutdown Supply Current	$2.7\text{V} \leq V_{IN} \leq 5.5\text{V}$, EN = OFF		3	4.5	μA
V_{SET}	I_{SET} Pin Voltage	$2.7\text{V} \leq V_{IN} \leq 5.5\text{V}$		1.25		V
I_{DXX}/I_{SET}	Output Current to Current Set Ratio			100		
R_{OUT}	Charge Pump Output Resistance ⁽⁶⁾	$V_{IN} = 3.0\text{V}$		2.7		Ω
V_{HR}	Current Source Headroom Voltage Requirement ⁽⁷⁾	$I_{DXX} = 95\% \times I_{DXX}(\text{nom})$ $R_{SET} = 8.35\text{k}\Omega$ ($I_{DXX}(\text{nom}) \approx 15\text{mA}$)		320		mV
		$I_{DXX} = 95\% \times I_{DXX}(\text{nom})$ $R_{SET} = 12.5\text{k}\Omega$ ($I_{DXX}(\text{nom}) \approx 10\text{mA}$)		220		
f_{SW}	Switching Frequency	$3.0\text{V} \leq V_{IN} \leq 4.2\text{V}$	325	500	675	kHz
t_{START}	Start-up Time	$I_{DXX} = 90\%$ steady state		100		μs
1.5x/1x	Charge pump gain cross-over: Gain = 1.5 when V_{IN} is below threshold. Gain = 1 when V_{IN} is above threshold.	1.5x to 1x Threshold		4.75		V
		1x to 1.5x Threshold		4.55		V
Logic Pin Specifications: EN, EN_A, EN_B						
V_{IL}	Input Logic Low	$2.7\text{V} \leq V_{IN} \leq 5.5\text{V}$	0		0.5	V

(1) All voltages are with respect to the potential at the GND pin.

(2) Min and Max limits are specified by design, test, or statistical analysis. Typical numbers are not specified, but do represent the most likely norm.

(3) If both LED groups are to be ON simultaneously, the maximum V_{DXX} voltage may need to be derated, depending on minimum input voltage conditions. Refer to the "MAXIMUM OUTPUT CURRENT, MAXIMUM LED VOLTAGE, MINIMUM INPUT VOLTAGE" section.

(4) C_{IN} , C_{OUT} , C_1 , and C_2 : Low-ESR Surface-Mount Ceramic Capacitors (MLCCs) used in setting electrical characteristics

(5) For the two groups of outputs on a part (Group A and Group B), the following are determined: the maximum output current in the group (MAX), the minimum output current in the group (MIN), and the average output current of the group (AVG). For each group, two matching numbers are calculated: (MAX-AVG)/AVG and (AVG-MIN)/AVG. The largest number of the two (worst case) is considered the matching figure for the group. The matching figure for a given part is considered to be the highest matching figure of the two groups. The typical specification provided is the most likely norm of the matching figure for all parts.

(6) Output resistance (R_{OUT}) models all voltage losses in the charge pump. R_{OUT} can be used to estimate the voltage at the charge pump output (P_{OUT}): $V_{P_OUT} = (1.5 \times V_{IN}) - (R_{OUT} \times I_{OUT})$. In the equation, I_{OUT} is the total output current: the sum of all active Dxx output currents and all current drawn from P_{OUT} . The equation applies when the charge pump is operating with a gain of 3/2 ($V_{IN} \leq 4.75\text{V}$ typ.).

(7) Headroom voltage: $V_{HR} = V_{P_OUT} - V_{DXX}$. If headroom voltage requirement is not met, LED current regulation will be compromised.

ELECTRICAL CHARACTERISTICS⁽¹⁾⁽²⁾ (continued)

Limits in standard typeface and typical values apply for $T_J = 25^\circ\text{C}$. Limits in **boldface** type apply over the full operating junction temperature range ($-30^\circ\text{C} \leq T_J \leq +85^\circ\text{C}$). Unless otherwise specified: $V_{IN} = 3.6\text{V}$; $V_{DXX} = 3.6\text{V}$; $V(\text{EN}) = 2.0\text{V}$; Group A and Group B LEDs not ON simultaneously⁽³⁾ ($\text{ENA} = V_{IN}$ and $\text{ENB} = \text{GND}$, or $\text{ENA} = \text{GND}$ and $\text{ENB} = V_{IN}$); $R_{SET} = 8.35\text{k}\Omega$; C_{IN} , C_1 , C_2 , and $C_{POUT} = 1\mu\text{F}$ ⁽⁴⁾.

Symbol	Parameter	Condition	Min	Typ	Max	Units
V_{IH}	Input Logic High	$2.7\text{V} \leq V_{IN} \leq 5.5\text{V}$	1.1		V_{IN}	V
I_{LEAK}	Input Leakage Current	$V_{ENx} = 0\text{V}$		0.1		μA
		$V_{ENx} = 3\text{V}$ ⁽⁸⁾		10		

(8) There is a $300\text{k}\Omega$ (typ.) pull-down resistor connected internally between each enable pin (EN, ENA, ENB) and GND.

TYPICAL PERFORMANCE CHARACTERISTICS

Unless otherwise specified: $V_{IN} = 3.6V$; $V_{DXX} = 3.6V$; $V(EN) = 2.0V$; $V(ENA) = 2.0V$; $V(ENB) = 0V$; $R_{SET} = 8.3\text{ k}\Omega$; $C_{IN}, C_1, C_2,$ and $C_{POUT} = 1\text{ }\mu\text{F}$.

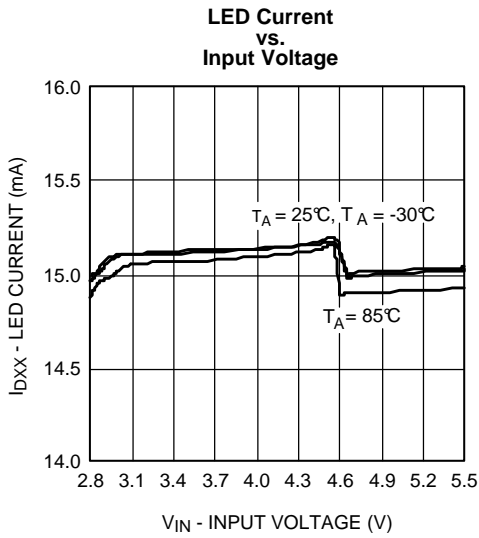

Figure 2.

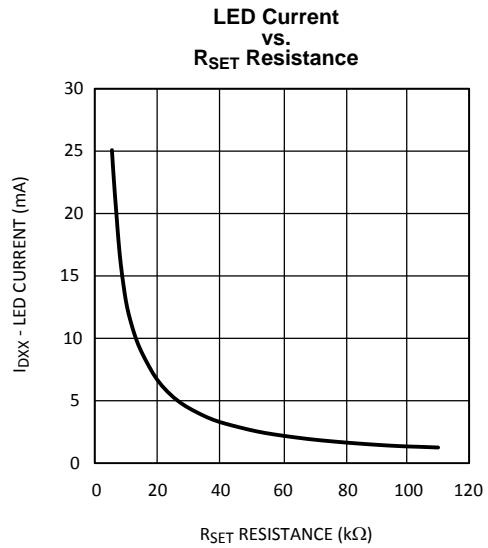

Figure 3.

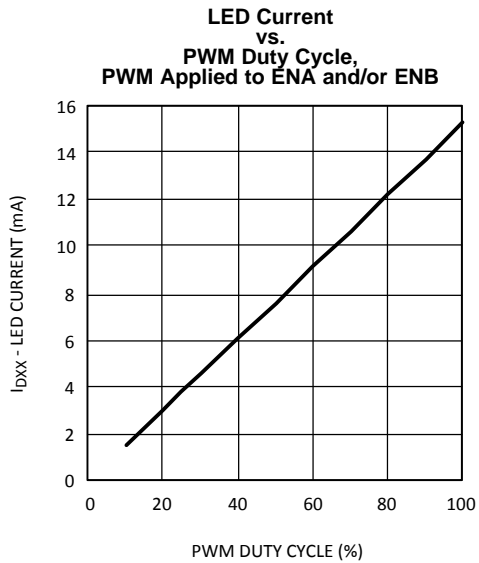

Figure 4.

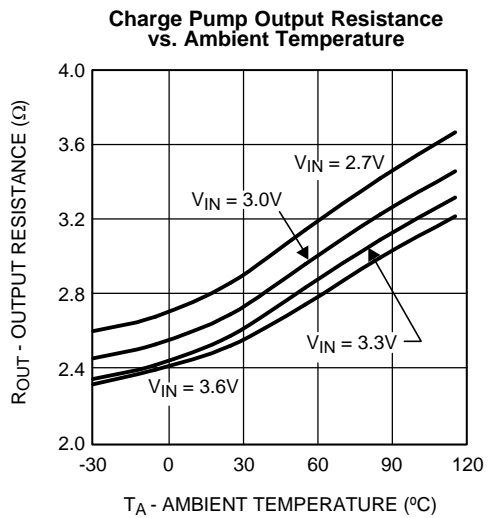

Figure 5.

CIRCUIT DESCRIPTION

OVERVIEW

The LM2796 is primarily intended for Lithium-Ion battery driven white-LED drive applications, and is well suited to drive white LEDs that are used for backlighting small-format displays. The part has seven matched constant-current outputs, each capable of driving up to 20mA (or more) through white LEDs. The well-matched current sources ensure the current through all the LEDs is virtually identical. This keeps brightness of all LEDs matched to near perfection so that they can provide a consistent backlight over the entire display.

The core of the LM2796 is a 1.5x/1x dual-mode charge pump. The input of the charge pump is connected to the V_{IN} pin. The recommended input voltage range of the LM2796 is 2.7V to 5.5V. The output of the charge pump is the P_{OUT} pin ("Pump OUTput"). The output voltage of the charge pump is unregulated and varies with input voltage and load current.

The charge pump operates in the 1.5x mode when the input voltage is below 4.75V (typ.). In this mode, the input-to-output voltage gain of the charge pump is 1.5, and the voltage at the output of the charge pump will be approximately 1.5x the input voltage ($V(P_{OUT}) \approx 1.5 * V_{IN}$). When in the 1.5x mode, the charge pump provides the voltage boost that is required to drive white LEDs from a Li-Ion battery. (White LEDs typically have a forward voltage in the range of 3.3V to 4.0V. A Li-Ion battery typically is not considered to be fully discharged until the battery voltage falls to 3.0V (approx.))

The charge pump operates in the 1x mode when the input voltage is above 4.75V (typ.). In these conditions, voltage boost is not required to drive the LEDs, so the charge pump merely passes the input voltage to P_{OUT} ($V(P_{OUT}) \approx V_{IN}$). This reduces the input current and the power dissipation of the LM2796 when the input voltage is high.

The matched current outputs are generated with a precision current mirror that is biased off the charge pump output. Matched currents are ensured with the use of tightly matched internal devices and internal mismatch cancellation circuitry. Top-side current drive allows LEDs to be connected between each current output and GND, simplifying PWB routing and connectivity.

There are seven regulated current outputs. These seven outputs are split into two groups, a group of 4 outputs and a group of 3 outputs. There is an ON/OFF control pin for each group.

The DC current through the LEDs is programmed with an external resistor. Changing currents on-the-fly can be achieved with the use of digital pulse (PWM) signals.

ENABLE PINS: EN, ENA, ENB

The LM2796 has 3 enable pins. All three are active-high logic (HIGH = ON). There are internal pull-down resistors (300k Ω typ.) that are connected internally between each of the enable pins and GND.

The EN pin is the master enable pin for the part. When voltage on this pin is low (<0.5V), the part is in shutdown mode. All internal circuitry is OFF and the part consumes very little supply current when the LM2796 is shutdown. When the voltage on the EN pin is high (>1.1V), the part is active. The charge pump is ON, and it is possible to turn on the output currents to drive the LEDs.

ENA and ENB are used to turn the output currents ON and OFF. ENA activates/deactivates the four group-A outputs (D1A-D4A). ENB activates/deactivates the three group-B outputs (D1B-D3B).

SETTING LED CURRENTS

The output currents of the LM2796 can be set to a desired value simply by connecting an appropriately sized resistor (R_{SET}) between the I_{SET} pin of the LM2796 and GND. The output currents (LED currents) are proportional to the current that flows out of the I_{SET} pin. The output currents are a factor of 100 greater than the I_{SET} current. The feedback loop of an internal amplifier sets the voltage of the I_{SET} pin to 1.25V (typ.). Placing a resistor between I_{SET} and GND programs the I_{SET} current, and thus the LED currents. The statements above are simplified in the equations below:

$$I_{Dxx} = 100 \times (V_{SET} / R_{SET}) \quad (1)$$

$$R_{SET} = 100 \times (1.25V / I_{Dxx}) \quad (2)$$

Maximum Output Current, Maximum LED Voltage, Minimum Input Voltage

The LM2796 can drive 7 LEDs at 15mA each from an input voltage as low as 3.0V, so long as the LEDs have a forward voltage of 3.6V or less (room temperature).

The statement above is a simple example of the LED drive capabilities of the LM2796. The statement contains the key application parameters that are required to validate an LED-drive design using the LM2796: LED current (I_{LED}), number of active LEDs (N), LED forward voltage (V_{LED}), and minimum input voltage (V_{IN-MIN}).

The equation below can be used to estimate the total output current capability of the LM2796:

$$I_{LED_MAX} = ((1.5 \times V_{IN}) - V_{LED}) / ((N \times R_{OUT}) + k_{HR}) \quad (3)$$

$$I_{LED_MAX} = ((1.5 \times V_{IN}) - V_{LED}) / ((N \times 2.7\Omega) + 22mV/mA)$$

R_{OUT} – Output resistance. This parameter models the internal losses of the charge pump that result in voltage droop at the pump output P_{OUT} . Since the magnitude of the voltage droop is proportional to the total output current of the charge pump, the loss parameter is modeled as a resistance. The output resistance of the LM2796 is typically 2.7Ω ($V_{IN} = 3.0V$, $T_A = 25^\circ C$). In equation form:

$$V_{POUT} = 1.5 \times V_{IN} - N \times I_{LED} \times R_{OUT} \quad (4)$$

k_{HR} – Headroom constant. This parameter models the minimum voltage required to be present across the current sources for them to regulate properly. This minimum voltage is proportional to the programmed LED current, so the constant has units of mV/mA. The typical k_{HR} of the LM2796 is 22mV/mA. In equation form:

$$(V_{POUT} - V_{LED}) > k_{HR} \times I_{LED} \quad (5)$$

The " $I_{LED-MAX}$ " equation (Equation 3) is obtained from combining the R_{OUT} equation (Equation 4) with the k_{HR} equation (Equation 5) and solving for I_{LED} . Maximum LED current is highly dependent on minimum input voltage and LED forward voltage. Output current capability can be increased by raising the minimum input voltage of the application, or by selecting an LED with a lower forward voltage. Excessive power dissipation may also limit output current capability of an application.

Soft Start

The LM2796 contains internal soft-start circuitry to limit input inrush currents when the part is enabled. Soft start is implemented internally with a controlled turn-on of the internal voltage reference. During soft start, the current through the LED outputs rise at the rate of the reference voltage ramp. Due to the soft-start circuitry, turn-on time of the LM2796 is approximately $100\mu s$ (typ.).

Thermal Protection

Internal thermal protection circuitry disables the LM2796 when the junction temperature exceeds $160^\circ C$ (typ.). This feature protects the device from being damaged by high die temperatures that might otherwise result from excessive power dissipation. The device will recover and operate normally when the junction temperature falls below $120^\circ C$ (typ.). It is important that the board layout provides good thermal conduction. This will help to keep the junction temperature within specified operating ratings.

APPLICATIONS INFORMATION

ADJUSTING LED BRIGHTNESS (PWM control)

Perceived LED brightness can be adjusted using a PWM control signal to turn the LM2796 current sources ON and OFF at a rate faster than perceptible by the eye. When this is done, the total brightness perceived is proportional to the duty cycle (D) of the PWM signal (D = the percentage of time that the LED is on in every PWM cycle). A simple example: if the LEDs are driven at 15mA each with a PWM signal that has a 50% duty cycle, perceived LED brightness will be about half as bright as compared to when the LEDs are driven continuously with 15mA. A PWM signal thus provides brightness (dimming) control for the solution.

The minimum recommended PWM frequency is 100Hz. Frequencies below this may be visibly noticeable as flicker or blinking. The maximum recommended PWM frequency is 1kHz. Frequencies above this may cause interference with internal current driver circuitry.

The preferred method for applying a PWM signal to adjust brightness is to keep the master EN voltage ON continuously and to apply the PWM signal(s) to the current source enable pin(s): ENA and/or ENB. The benefit of this type of connection can be best understood with a contrary example. When a PWM signal is connected to the master enable (EN) pin, the charge pump repeatedly turns on and off. Every time the charge pump turns on, there is an inrush of current as capacitances, both internal and external, are recharged. This inrush current results in a current and voltage spike at the input of the part. By only applying the PWM signal to ENA/ENB, the charge pump stays on continuously and much lower input noise results.

In cases where a PWM signal must be connected to the EN pin, measures can be taken to reduce the magnitude of the charge-pump turn-on voltage spikes. More input capacitance, series resistors and/or ferrite beads may provide benefits.

If the current and voltage spikes can be tolerated, connecting the PWM signal to the EN pin does provide a benefit: lower supply current when the PWM signal is active. When the PWM signal is low, the LM2796 will be shutdown and input current will only be a few micro-amps. This results in a lower time-averaged input current than the prior suggestion, where EN is kept on continuously.

CAPACITOR SELECTION

The LM2796 requires 4 external capacitors for proper operation. Surface-mount multi-layer ceramic capacitors are recommended. These capacitors are small, inexpensive and have very low equivalent series resistance (ESR <20mΩ typ.). Tantalum capacitors, OS-CON capacitors, and aluminum electrolytic capacitors are not recommended for use with the LM2796 due to their high ESR, as compared to ceramic capacitors.

For most applications, ceramic capacitors with X7R or X5R temperature characteristic are preferred for use with the LM2796. These capacitors have tight capacitance tolerance (as good as ±10%) and hold their value over temperature (X7R: ±15% over -55°C to 125°C; X5R: ±15% over -55°C to 85°C).

Capacitors with Y5V or Z5U temperature characteristic are generally not recommended for use with the LM2796. Capacitors with these temperature characteristics typically have wide capacitance tolerance (+80%, -20%) and vary significantly over temperature (Y5V: +22%, -82% over -30°C to +85°C range; Z5U: +22%, -56% over +10°C to +85°C range). Under some conditions, a nominal 1μF Y5V or Z5U capacitor could have a capacitance of only 0.1μF. Such detrimental deviation is likely to cause Y5V and Z5U capacitors to fail to meet the minimum capacitance requirements of the LM2796.

The minimum recommended voltage rating for these capacitors is 10V.

DSBGA MOUNTING

The LM2796 is an 18-bump DSBGA with a bump size of approximately 300 micron diameter. The DSBGA package requires specific mounting techniques detailed in Texas Instruments' Application Note 1112 (Literature Number [SNVA009](#)).

REVISION HISTORY

Changes from Original (May 2013) to Revision A	Page
• Changed layout of National Data Sheet to TI format	9

PACKAGING INFORMATION

Orderable Device	Status (1)	Package Type	Package Drawing	Pins	Package Qty	Eco Plan (2)	Lead/Ball Finish (6)	MSL Peak Temp (3)	Op Temp (°C)	Device Marking (4/5)	Samples
LM2796TL/NOPB	ACTIVE	DSBGA	YZR	18	250	Green (RoHS & no Sb/Br)	SNAGCU	Level-1-260C-UNLIM	-30 to 85	SAJB	Samples
LM2796TLX/NOPB	ACTIVE	DSBGA	YZR	18	3000	Green (RoHS & no Sb/Br)	SNAGCU	Level-1-260C-UNLIM	-30 to 85	SAJB	Samples

(1) The marketing status values are defined as follows:

ACTIVE: Product device recommended for new designs.

LIFEBUY: TI has announced that the device will be discontinued, and a lifetime-buy period is in effect.

NRND: Not recommended for new designs. Device is in production to support existing customers, but TI does not recommend using this part in a new design.

PREVIEW: Device has been announced but is not in production. Samples may or may not be available.

OBsolete: TI has discontinued the production of the device.

(2) Eco Plan - The planned eco-friendly classification: Pb-Free (RoHS), Pb-Free (RoHS Exempt), or Green (RoHS & no Sb/Br) - please check <http://www.ti.com/productcontent> for the latest availability information and additional product content details.

TBD: The Pb-Free/Green conversion plan has not been defined.

Pb-Free (RoHS): TI's terms "Lead-Free" or "Pb-Free" mean semiconductor products that are compatible with the current RoHS requirements for all 6 substances, including the requirement that lead not exceed 0.1% by weight in homogeneous materials. Where designed to be soldered at high temperatures, TI Pb-Free products are suitable for use in specified lead-free processes.

Pb-Free (RoHS Exempt): This component has a RoHS exemption for either 1) lead-based flip-chip solder bumps used between the die and package, or 2) lead-based die adhesive used between the die and leadframe. The component is otherwise considered Pb-Free (RoHS compatible) as defined above.

Green (RoHS & no Sb/Br): TI defines "Green" to mean Pb-Free (RoHS compatible), and free of Bromine (Br) and Antimony (Sb) based flame retardants (Br or Sb do not exceed 0.1% by weight in homogeneous material)

(3) MSL, Peak Temp. - The Moisture Sensitivity Level rating according to the JEDEC industry standard classifications, and peak solder temperature.

(4) There may be additional marking, which relates to the logo, the lot trace code information, or the environmental category on the device.

(5) Multiple Device Markings will be inside parentheses. Only one Device Marking contained in parentheses and separated by a "~" will appear on a device. If a line is indented then it is a continuation of the previous line and the two combined represent the entire Device Marking for that device.

(6) Lead/Ball Finish - Orderable Devices may have multiple material finish options. Finish options are separated by a vertical ruled line. Lead/Ball Finish values may wrap to two lines if the finish value exceeds the maximum column width.

Important Information and Disclaimer: The information provided on this page represents TI's knowledge and belief as of the date that it is provided. TI bases its knowledge and belief on information provided by third parties, and makes no representation or warranty as to the accuracy of such information. Efforts are underway to better integrate information from third parties. TI has taken and continues to take reasonable steps to provide representative and accurate information but may not have conducted destructive testing or chemical analysis on incoming materials and chemicals. TI and TI suppliers consider certain information to be proprietary, and thus CAS numbers and other limited information may not be available for release.

In no event shall TI's liability arising out of such information exceed the total purchase price of the TI part(s) at issue in this document sold by TI to Customer on an annual basis.

TAPE AND REEL INFORMATION

QUADRANT ASSIGNMENTS FOR PIN 1 ORIENTATION IN TAPE

*All dimensions are nominal

Device	Package Type	Package Drawing	Pins	SPQ	Reel Diameter (mm)	Reel Width W1 (mm)	A0 (mm)	B0 (mm)	K0 (mm)	P1 (mm)	W (mm)	Pin1 Quadrant
LM2796TL/NOPB	DSBGA	YZR	18	250	178.0	8.4	2.29	2.59	0.76	4.0	8.0	Q1
LM2796TLX/NOPB	DSBGA	YZR	18	3000	178.0	8.4	2.29	2.59	0.76	4.0	8.0	Q1

TAPE AND REEL BOX DIMENSIONS

*All dimensions are nominal

Device	Package Type	Package Drawing	Pins	SPQ	Length (mm)	Width (mm)	Height (mm)
LM2796TL/NOPB	DSBGA	YZR	18	250	210.0	185.0	35.0
LM2796TLX/NOPB	DSBGA	YZR	18	3000	210.0	185.0	35.0

YZR0018

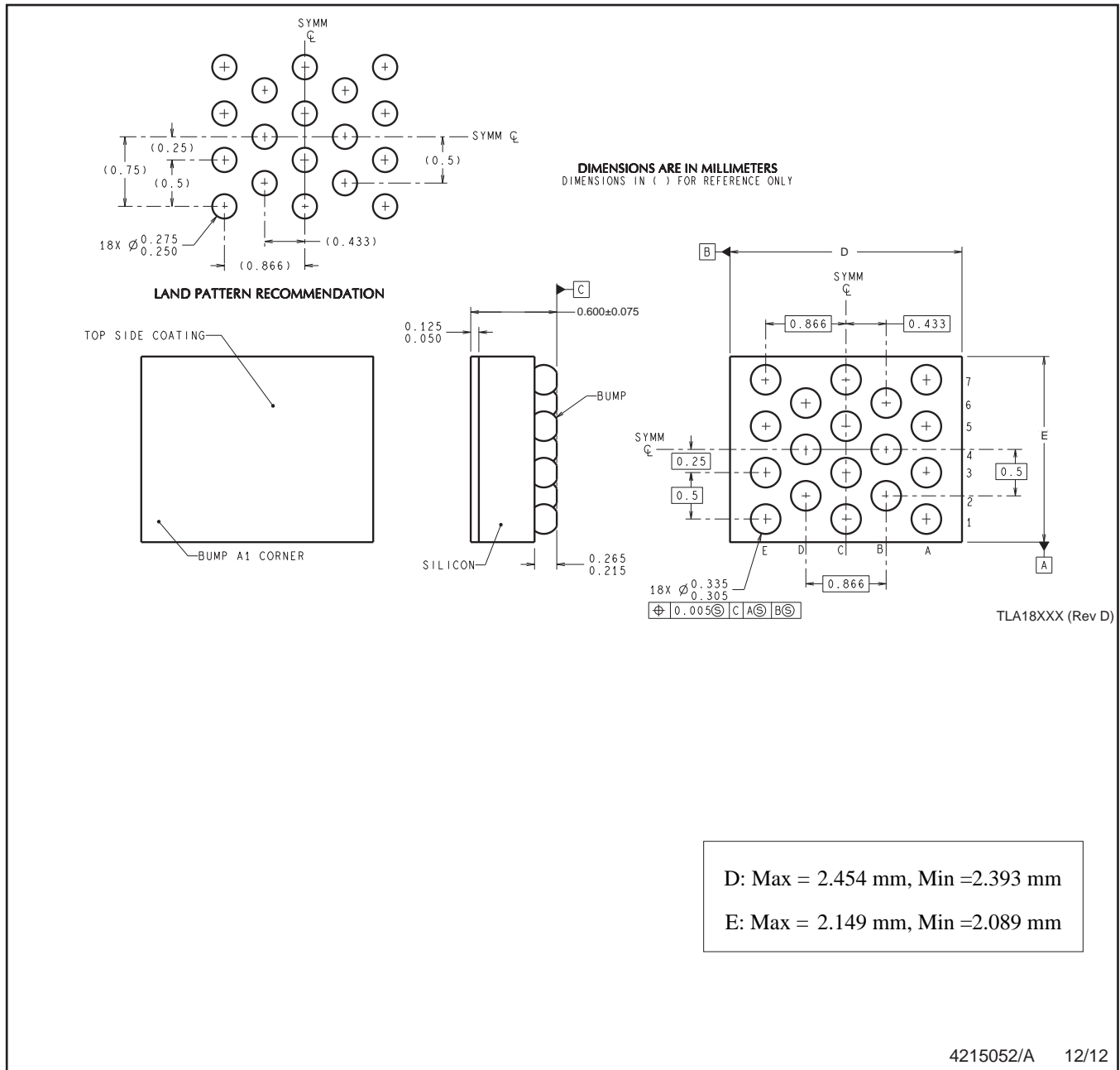

NOTES: A. All linear dimensions are in millimeters. Dimensioning and tolerancing per ASME Y14.5M-1994.
B. This drawing is subject to change without notice.

4215052/A 12/12

IMPORTANT NOTICE

Texas Instruments Incorporated (TI) reserves the right to make corrections, enhancements, improvements and other changes to its semiconductor products and services per JESD46, latest issue, and to discontinue any product or service per JESD48, latest issue. Buyers should obtain the latest relevant information before placing orders and should verify that such information is current and complete.

TI's published terms of sale for semiconductor products (<http://www.ti.com/sc/docs/stdterms.htm>) apply to the sale of packaged integrated circuit products that TI has qualified and released to market. Additional terms may apply to the use or sale of other types of TI products and services.

Reproduction of significant portions of TI information in TI data sheets is permissible only if reproduction is without alteration and is accompanied by all associated warranties, conditions, limitations, and notices. TI is not responsible or liable for such reproduced documentation. Information of third parties may be subject to additional restrictions. Resale of TI products or services with statements different from or beyond the parameters stated by TI for that product or service voids all express and any implied warranties for the associated TI product or service and is an unfair and deceptive business practice. TI is not responsible or liable for any such statements.

Buyers and others who are developing systems that incorporate TI products (collectively, "Designers") understand and agree that Designers remain responsible for using their independent analysis, evaluation and judgment in designing their applications and that Designers have full and exclusive responsibility to assure the safety of Designers' applications and compliance of their applications (and of all TI products used in or for Designers' applications) with all applicable regulations, laws and other applicable requirements. Designer represents that, with respect to their applications, Designer has all the necessary expertise to create and implement safeguards that (1) anticipate dangerous consequences of failures, (2) monitor failures and their consequences, and (3) lessen the likelihood of failures that might cause harm and take appropriate actions. Designer agrees that prior to using or distributing any applications that include TI products, Designer will thoroughly test such applications and the functionality of such TI products as used in such applications.

TI's provision of technical, application or other design advice, quality characterization, reliability data or other services or information, including, but not limited to, reference designs and materials relating to evaluation modules, (collectively, "TI Resources") are intended to assist designers who are developing applications that incorporate TI products; by downloading, accessing or using TI Resources in any way, Designer (individually or, if Designer is acting on behalf of a company, Designer's company) agrees to use any particular TI Resource solely for this purpose and subject to the terms of this Notice.

TI's provision of TI Resources does not expand or otherwise alter TI's applicable published warranties or warranty disclaimers for TI products, and no additional obligations or liabilities arise from TI providing such TI Resources. TI reserves the right to make corrections, enhancements, improvements and other changes to its TI Resources. TI has not conducted any testing other than that specifically described in the published documentation for a particular TI Resource.

Designer is authorized to use, copy and modify any individual TI Resource only in connection with the development of applications that include the TI product(s) identified in such TI Resource. NO OTHER LICENSE, EXPRESS OR IMPLIED, BY ESTOPPEL OR OTHERWISE TO ANY OTHER TI INTELLECTUAL PROPERTY RIGHT, AND NO LICENSE TO ANY TECHNOLOGY OR INTELLECTUAL PROPERTY RIGHT OF TI OR ANY THIRD PARTY IS GRANTED HEREIN, including but not limited to any patent right, copyright, mask work right, or other intellectual property right relating to any combination, machine, or process in which TI products or services are used. Information regarding or referencing third-party products or services does not constitute a license to use such products or services, or a warranty or endorsement thereof. Use of TI Resources may require a license from a third party under the patents or other intellectual property of the third party, or a license from TI under the patents or other intellectual property of TI.

TI RESOURCES ARE PROVIDED "AS IS" AND WITH ALL FAULTS. TI DISCLAIMS ALL OTHER WARRANTIES OR REPRESENTATIONS, EXPRESS OR IMPLIED, REGARDING RESOURCES OR USE THEREOF, INCLUDING BUT NOT LIMITED TO ACCURACY OR COMPLETENESS, TITLE, ANY EPIDEMIC FAILURE WARRANTY AND ANY IMPLIED WARRANTIES OF MERCHANTABILITY, FITNESS FOR A PARTICULAR PURPOSE, AND NON-INFRINGEMENT OF ANY THIRD PARTY INTELLECTUAL PROPERTY RIGHTS. TI SHALL NOT BE LIABLE FOR AND SHALL NOT DEFEND OR INDEMNIFY DESIGNER AGAINST ANY CLAIM, INCLUDING BUT NOT LIMITED TO ANY INFRINGEMENT CLAIM THAT RELATES TO OR IS BASED ON ANY COMBINATION OF PRODUCTS EVEN IF DESCRIBED IN TI RESOURCES OR OTHERWISE. IN NO EVENT SHALL TI BE LIABLE FOR ANY ACTUAL, DIRECT, SPECIAL, COLLATERAL, INDIRECT, PUNITIVE, INCIDENTAL, CONSEQUENTIAL OR EXEMPLARY DAMAGES IN CONNECTION WITH OR ARISING OUT OF TI RESOURCES OR USE THEREOF, AND REGARDLESS OF WHETHER TI HAS BEEN ADVISED OF THE POSSIBILITY OF SUCH DAMAGES.

Unless TI has explicitly designated an individual product as meeting the requirements of a particular industry standard (e.g., ISO/TS 16949 and ISO 26262), TI is not responsible for any failure to meet such industry standard requirements.

Where TI specifically promotes products as facilitating functional safety or as compliant with industry functional safety standards, such products are intended to help enable customers to design and create their own applications that meet applicable functional safety standards and requirements. Using products in an application does not by itself establish any safety features in the application. Designers must ensure compliance with safety-related requirements and standards applicable to their applications. Designer may not use any TI products in life-critical medical equipment unless authorized officers of the parties have executed a special contract specifically governing such use. Life-critical medical equipment is medical equipment where failure of such equipment would cause serious bodily injury or death (e.g., life support, pacemakers, defibrillators, heart pumps, neurostimulators, and implantables). Such equipment includes, without limitation, all medical devices identified by the U.S. Food and Drug Administration as Class III devices and equivalent classifications outside the U.S.

TI may expressly designate certain products as completing a particular qualification (e.g., Q100, Military Grade, or Enhanced Product). Designers agree that it has the necessary expertise to select the product with the appropriate qualification designation for their applications and that proper product selection is at Designers' own risk. Designers are solely responsible for compliance with all legal and regulatory requirements in connection with such selection.

Designer will fully indemnify TI and its representatives against any damages, costs, losses, and/or liabilities arising out of Designer's non-compliance with the terms and provisions of this Notice.

Looking for pricing, stock, or lifecycle information?

Click below to explore more details on WIN SOURCE:

 [View LM2796TL/NOPB on WIN SOURCE](#)

 [Texas Instruments](#) Information

Optimize Your Supply Chain with WIN SOURCE Solutions

-  Global Sourcing Solution
-  Obsolete Management
-  Cost Control Management
-  Shortage Management
-  Alternative Solution
-  Excess Inventory Management