



# THE DATASHEET OF LM2795TL



# LM2794 /LM2795 Current Regulated Switched Capacitor LED Supply with Analog and PWM Brightness Control

 Check for Samples: [LM2794](#), [LM2795](#)

## FEATURES

- Regulated Current Sources with  $\pm 0.5\%$  Matching between any Two Outputs
- High Efficiency 3/2 Boost Function
- Drives One, Two, Three or four White LEDs
- 2.7V to 5.5V Input Voltage
- Up to 80mA Output Current
- Analog Brightness Control
- Active-Low or High Shutdown Input ('94/95)
- Very Small Solution Size and no Inductor
- 2.3 $\mu$ A (typ.) Shutdown Current
- 325kHz Switching Frequency (min.)
- Constant Frequency Generates Predictable Noise Spectrum
- Thin DSBGA Package: 2.08mm X 2.403mm X 0.600mm High

## APPLICATIONS

- White LED Display Backlights
- White LED Keypad Backlights
- 1-Cell Li-Ion Battery-Operated Equipment Including PDAs, Hand-Held PCs, Cellular Phones

## DESCRIPTION

The LM2794/95 is a fractional CMOS charge-pump that provides four regulated current sources. It accepts an input voltage range from 2.7V to 5.5V and maintains a constant current determined by an external sense resistor.

The LM2794/5 delivers up to 80mA of load current to accommodate four White LEDs. The switching frequency is 325kHz. (min.) to keep the conducted noise spectrum away from sensitive frequencies within portable RF devices.

## Basic Application Circuit

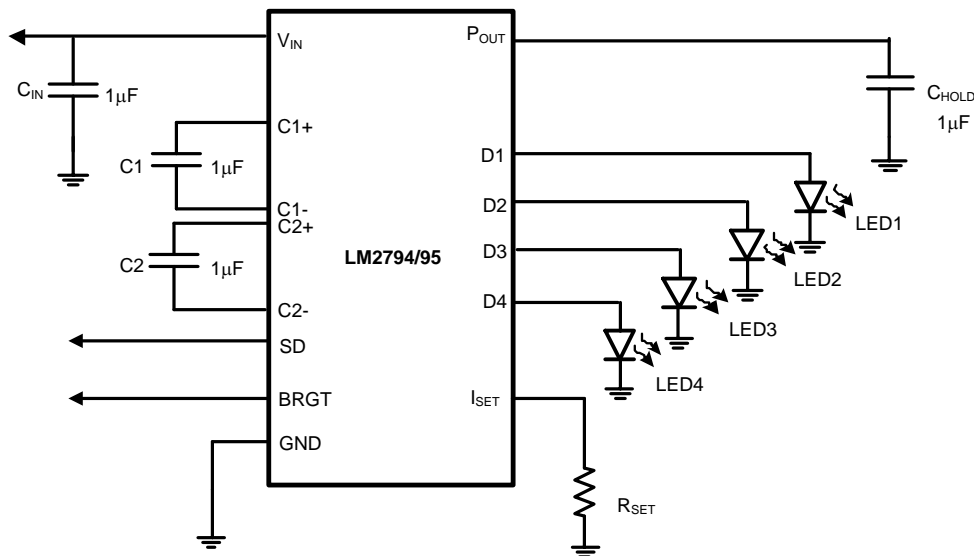

Please be aware that an important notice concerning availability, standard warranty, and use in critical applications of Texas Instruments semiconductor products and disclaimers thereto appears at the end of this data sheet.

All trademarks are the property of their respective owners.

**DESCRIPTION (CONTINUED)**

Brightness can be controlled by both linear and PWM techniques. A voltage between 0V and 3.0V may be applied to the BRGT pin to linearly vary the LED current. Alternatively, a PWM signal can be applied to the SD pin to vary the perceived brightness of the LED. The SD pin reduces the operating current to 2.3µA (typ.) The LM2794 is shut down when the SD pin is low, and the LM2795 is shut down when the SD pin is high.

The LM2794/95 is available in a DSBGA CSP package.

**Connection Diagram**

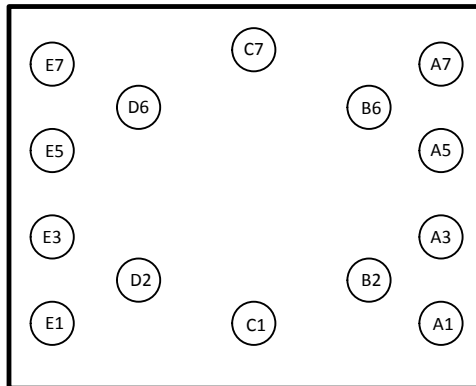

**Figure 1. DSBGA Package Bottom View**

**PIN DESCRIPTION**

Pin <sup>(1)</sup>	Name	Function
A1	C1+	Positive terminal of C1
B2	C1-	Negative terminal of C1
C1	V <sub>IN</sub>	Power supply voltage input
D2	GND	Power supply ground input
E1	C2-	Negative terminal of C2
E3,E5,E7,D6	D1-4	Current source outputs. Connect directly to LED
C7	I <sub>SET</sub>	Current Sense Input. Connect 1% resistor to ground to set constant current through LED
B6	BRGT	Variable voltage input controls output current
A7	SD	The LM2794 has an active-low shutdown pin (LOW = shutdown, HIGH = operating). The LM2795 has an active-high shutdown pin (HIGH = shutdown, LOW = operating) that has a pull-up to V <sub>IN</sub> .
A5	C2+	Positive terminal of C2
A3	P <sub>OUT</sub>	Charge pump output

(1) Note that the pin numbering scheme for the DSBGA package was revised in April, 2002 to conform to JEDEC standard. Only the pin numbers were revised. No changes to the physical location of the inputs/outputs were made. For reference purpose, the obsolete numbering had C1+ as pin 1, C1- as pin 2, V<sub>IN</sub> as pin 3, GND as pin 4, C2- as pin 5, D1-D4 as pin 6,7,8 & 9, Iset as pin 10, BRGT as pin 11, SD as pin 12, C2+ as pin 13, Pout as pin 14



These devices have limited built-in ESD protection. The leads should be shorted together or the device placed in conductive foam during storage or handling to prevent electrostatic damage to the MOS gates.

**Absolute Maximum Ratings** <sup>(1)(2)</sup>

$V_{IN}$	-0.5 to 6.2V max
SD	-0.5 to ( $V_{IN}+0.3V$ ) w/ 6.2V max
BRGT	-0.5 to ( $V_{IN}+0.3V$ ) w/ 6.2V max
Continuous Power Dissipation <sup>(3)</sup>	Internally Limited
$T_{JMAX}$ <sup>(3)</sup>	135°C
$\theta_{JA}$ <sup>(3) (4)</sup>	125°C/W
Storage Temperature	-65°C to +150°C
Lead Temp. (Soldering, 5 sec.)	260°C
ESD Rating <sup>(5)</sup>	
Human Body Model	2kV
Machine Model	200V

- (1) Absolute maximum ratings indicate limits beyond which damage to the device may occur. Electrical specifications do not apply when operating the device beyond its rated operating conditions.
- (2) Military/Aerospace specified devices are required, please contact the Texas Instruments Sales Office/ Distributors for availability and specifications.
- (3) Internal thermal shutdown circuitry protects the device from permanent damage. Thermal shutdown engages at  $T_J=150^\circ\text{C}$  (typ.) and disengages at  $T_J=140^\circ\text{C}$  (typ.). D1, D2, D3 and D4 may be shorted to GND without damage.  $P_{OUT}$  may be shorted to GND for 1sec without damage.
- (4) The value of  $\theta_{JA}$  is based on a two layer evaluation board with a dimension of 2in. x1.5in.
- (5) In the test circuit, all capacitors are 1.0 $\mu\text{F}$ , 0.3 $\Omega$  maximum ESR capacitors. Capacitors with higher ESR will increase output resistance, reduce output voltage and efficiency.

**Operating Conditions**

Input Voltage ( $V_{IN}$ )	2.7V to 5.5V
Ambient Temperature ( $T_A$ )	-30°C to +85°C
Junction Temperature ( $T_J$ )	-30°C to +100°C

**Electrical Characteristics**

Limits in standard typeface are for  $T_J = 25^\circ\text{C}$  and limits in **boldface type** apply over the full **Operating Junction Temperature Range** ( $-30^\circ\text{C} \leq T_J \leq +100^\circ\text{C}$ ). Unless otherwise specified,  $C1 = C2 = C_{IN} = C_{HOLD} = 1 \mu\text{F}$ ,  $V_{IN} = 3.6V$ , BRGT pin = 0V;  $R_{SET} = 124\Omega$ ; LM2794:  $V_{SD} = V_{IN}$  (LM2795:  $V_{SD} = 0V$ ).

Symbol	Parameter	Conditions	Min	Typ	Max	Units
$I_{DX}$	Available Current at Output Dx	$3.0V \leq V_{IN} \leq 5.5V$ $V_{DX} \leq 3.8V$ BRGT = 50mV	<b>15</b>	16.8		mA
		$2.7V \leq V_{IN} \leq 3.0V$ $V_{DX} \leq 3.6V$ BRGT = 0V	10		mA	
		$V_{DX} \leq 3.8V$ BRGT = 200mV	20			mA
$V_{DX}$	Available Voltage at Output Dx	$3.0V \leq V_{IN} \leq 5.5V$ $I_{DX} \leq 15\text{mA}$ BRGT = 50mV	<b>3.8</b>			
$I_{DX}$	Line Regulation of Dx Output Current	$3.0V \leq V_{IN} \leq 5.5V$ $V_{DX} = 3.6V$	<b>14.18</b>	15.25	<b>16.78</b>	mA
		$3.0V \leq V_{IN} \leq 4.4V$ $V_{DX} = 3.6V$	<b>14.18</b>	15.25	<b>16.32</b>	
$I_{DX}$	Load Regulation of Dx Output Current	$V_{IN} = 3.6V$ $3.0V \leq V_{DX} \leq 3.8V$	<b>14.18</b>	15.25	<b>16.32</b>	mA
$I_{D-MATCH}$	Current Matching Between Any Two Outputs	$V_{IN} = 3.6V$ , $V_{DX} = 3.6V$		0.5		%
$I_Q$	Quiescent Supply Current	$3.0V \leq V_{IN} \leq 4.2V$ , Active, No Load Current $R_{SET} = \text{OPEN}$		5.5	<b>8.2</b>	mA
$I_{SD}$	Shutdown Supply Current	$3.0V \leq V_{IN} \leq 5.5V$ , Shutdown		2.3	<b>5</b>	$\mu\text{A}$

### Electrical Characteristics (continued)

Limits in standard typeface are for  $T_J = 25^\circ\text{C}$  and limits in **boldface type** apply over the full **Operating Junction Temperature Range** ( $-30^\circ\text{C} \leq T_J \leq +100^\circ\text{C}$ ). Unless otherwise specified,  $C_1 = C_2 = C_{\text{IN}} = C_{\text{HOLD}} = 1 \mu\text{F}$ ,  $V_{\text{IN}} = 3.6\text{V}$ , BRGT pin = 0V;  $R_{\text{SET}} = 124\Omega$ ; LM2794:  $V_{\text{SD}} = V_{\text{IN}}$  (LM2795:  $V_{\text{SD}} = 0\text{V}$ ).

Symbol	Parameter	Conditions	Min	Typ	Max	Units
$I_{\text{PULL-SD}}$	Shutdown Pull-Up Current (LM2795)	$V_{\text{IN}} = 3.6\text{V}$		1.5		$\mu\text{A}$
$V_{\text{CP}}$	Input Charge-Pump Mode To Pass Mode Threshold			4.7		V
$V_{\text{CPH}}$	Input Charge-Pump Mode To Pass Mode Hysteresis	<sup>(1)</sup>		250		mV
$V_{\text{IH}}$	SD Input Logic High (LM2794)	$3.0\text{V} \leq V_{\text{IN}} \leq 5.5\text{V}$	1.0			V
	SD Input Logic High (LM2795)		$0.8V_{\text{IN}}$			
$V_{\text{IL}}$	SD Input Logic Low (LM2794)	$3.0\text{V} \leq V_{\text{IN}} \leq 5.5\text{V}$			0.2	V
	SD Input Logic Low (LM2795)				$0.2V_{\text{IN}}$	
$I_{\text{LEAK-SD}}$	SD Input Leakage Current	$0\text{V} \leq V_{\text{SD}} \leq V_{\text{IN}}$		100		nA
$R_{\text{BRGT}}$	BRGT Input Resistance			240		$\text{k}\Omega$
$I_{\text{SET}}$	$I_{\text{SET}}$ Pin Output Current			$I_{\text{DX}}/10$		mA
$f_{\text{SW}}$	Switching Frequency <sup>(2)</sup>	$3.0\text{V} \leq V_{\text{IN}} \leq 4.4\text{V}$	<b>325</b>	515	<b>675</b>	kHz

- (1) Voltage at which the device switches from charge-pump mode to pass mode or pass mode to charge-pump mode. For example, during pass mode the device output (Pout) follows the input voltage.
- (2) The output switches operate at one eighth of the oscillator frequency,  $f_{\text{OSC}} = 1/8f_{\text{SW}}$ .

### Typical Performance Characteristics

Unless otherwise specified,  $C_1 = C_2 = C_{IN} = C_{HOLD} = 1\mu\text{F}$ ,  $V_{IN} = 3.6\text{V}$ ,  $\text{BRGT pin} = 0\text{V}$ ,  $R_{SET} = 124\Omega$ .

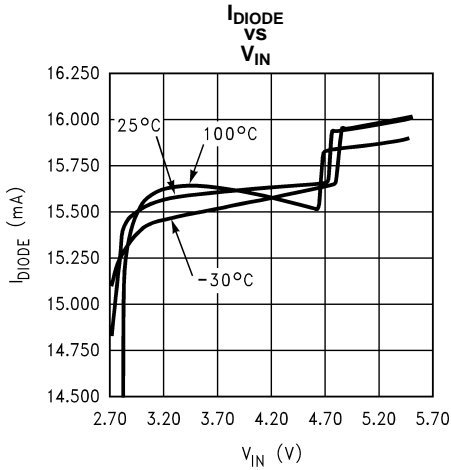

Figure 2.

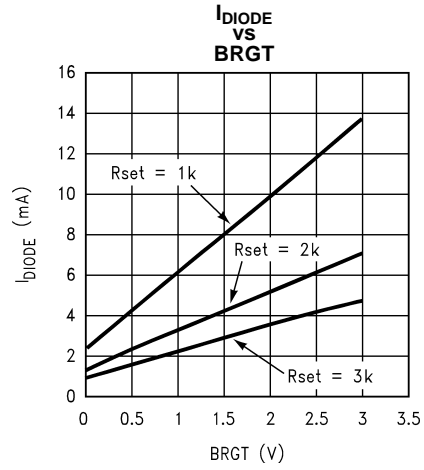

Figure 3.

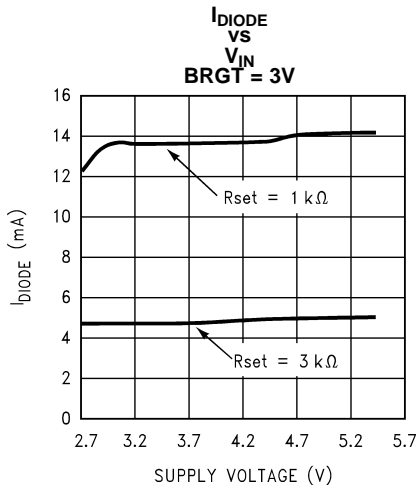

Figure 4.

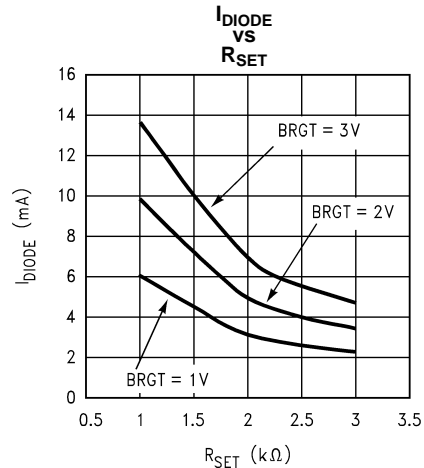

Figure 5.

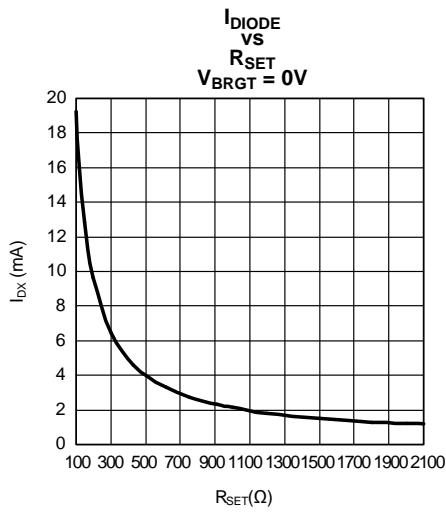

Figure 6.

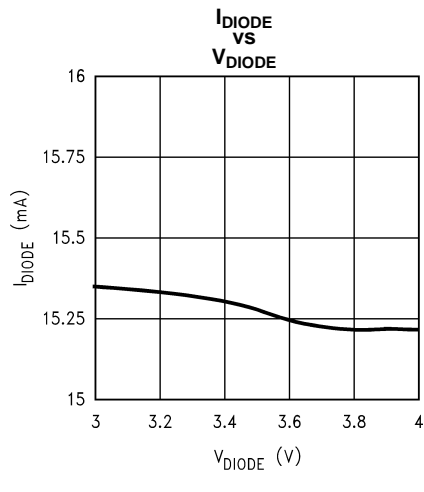

Figure 7.

**Typical Performance Characteristics (continued)**

Unless otherwise specified,  $C1 = C2 = C_{IN} = C_{HOLD} = 1\mu F$ ,  $V_{IN} = 3.6V$ , BRGT pin = 0V,  $R_{SET} = 124\Omega$ .

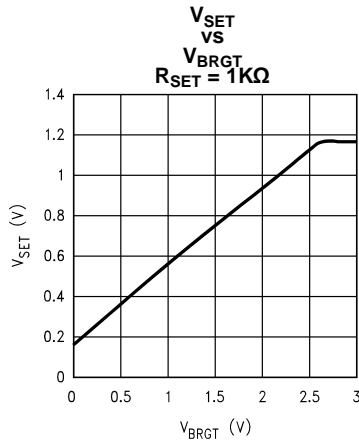

Figure 8.

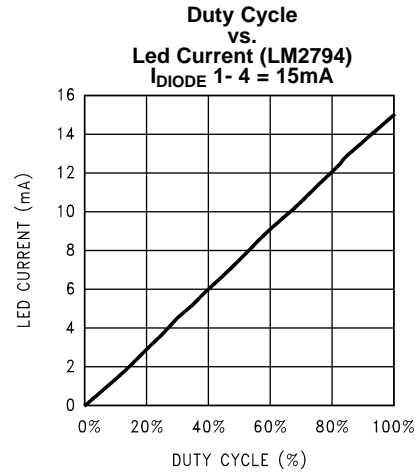

Figure 9.

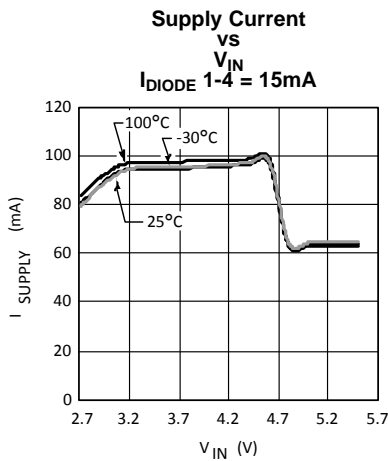

Figure 10.

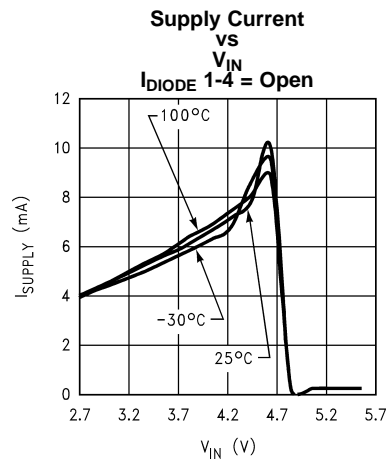

Figure 11.

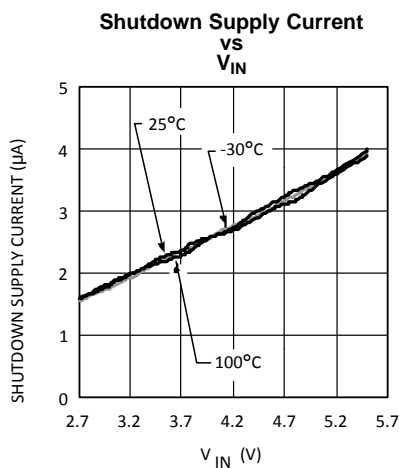

Figure 12.

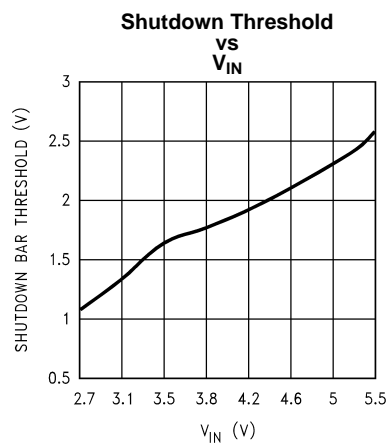
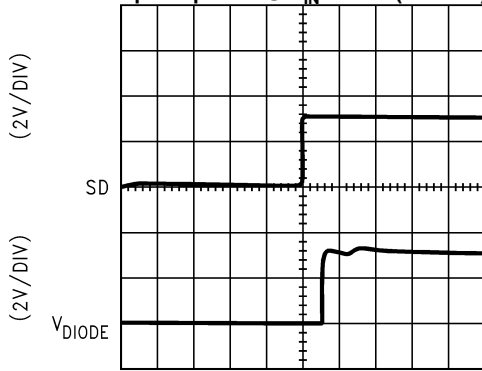

Figure 13.

**Typical Performance Characteristics (continued)**

Unless otherwise specified,  $C_1 = C_2 = C_{IN} = C_{HOLD} = 1\mu\text{F}$ ,  $V_{IN} = 3.6\text{V}$ , BRGT pin = 0V,  $R_{SET} = 124\Omega$ .

**Start-Up Response @  $V_{IN} = 2.7\text{V}$  (LM2794)**



TIME (50  $\mu\text{s}$ )  
Figure 14.

**Start-Up Response @  $V_{IN} = 2.7\text{V}$  (LM2795)**

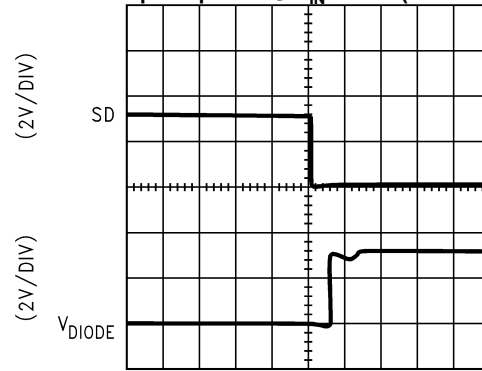

TIME (50  $\mu\text{s}$ )  
Figure 15.

**Start-Up Response @  $V_{IN} = 3.6\text{V}$  (LM2794)**

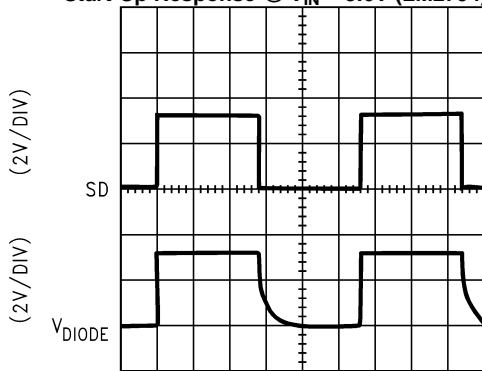

TIME (2 ms)  
Figure 16.

**Start-Up Response @  $V_{IN} = 3.6\text{V}$  (LM2795)**

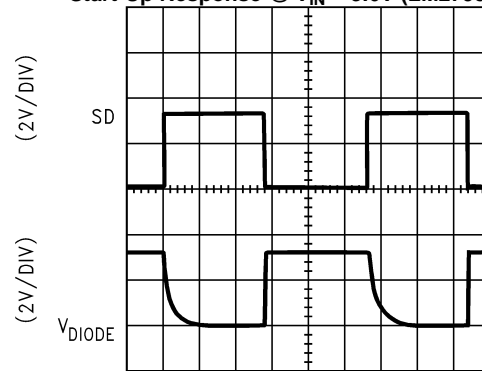

TIME (2 ms)  
Figure 17.

**Start-Up Response @  $V_{IN} = 4.2\text{V}$  (LM2794)**

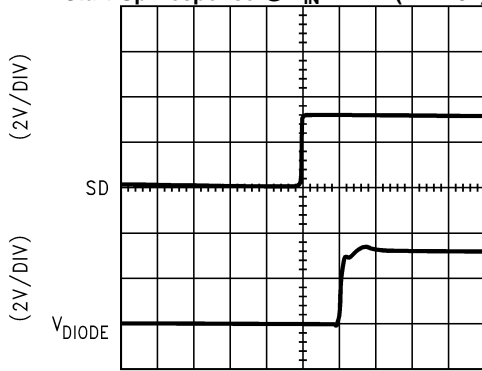

TIME (10  $\mu\text{s}$ )  
Figure 18.

**Start-Up Response @  $V_{IN} = 4.2\text{V}$  (LM2795)**

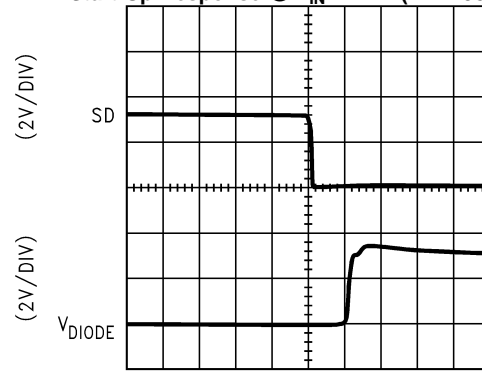

TIME (10  $\mu\text{s}$ )  
Figure 19.

**Typical Performance Characteristics (continued)**

Unless otherwise specified,  $C1 = C2 = C_{IN} = C_{HOLD} = 1\mu F$ ,  $V_{IN} = 3.6V$ , BRGT pin = 0V,  $R_{SET} = 124\Omega$ .

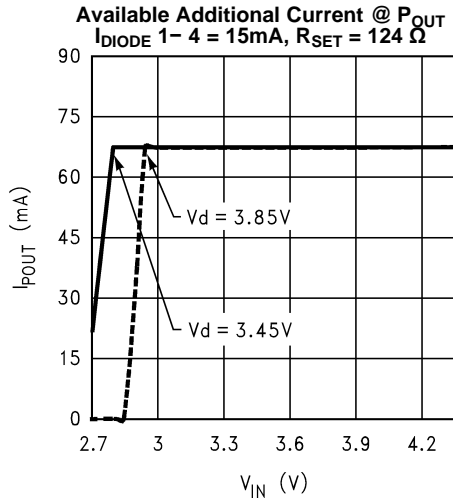

Figure 20.

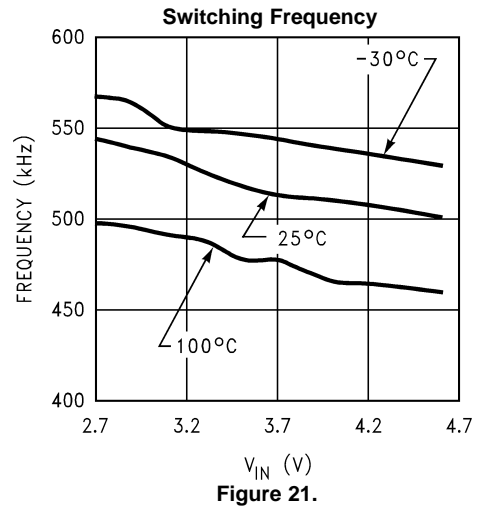
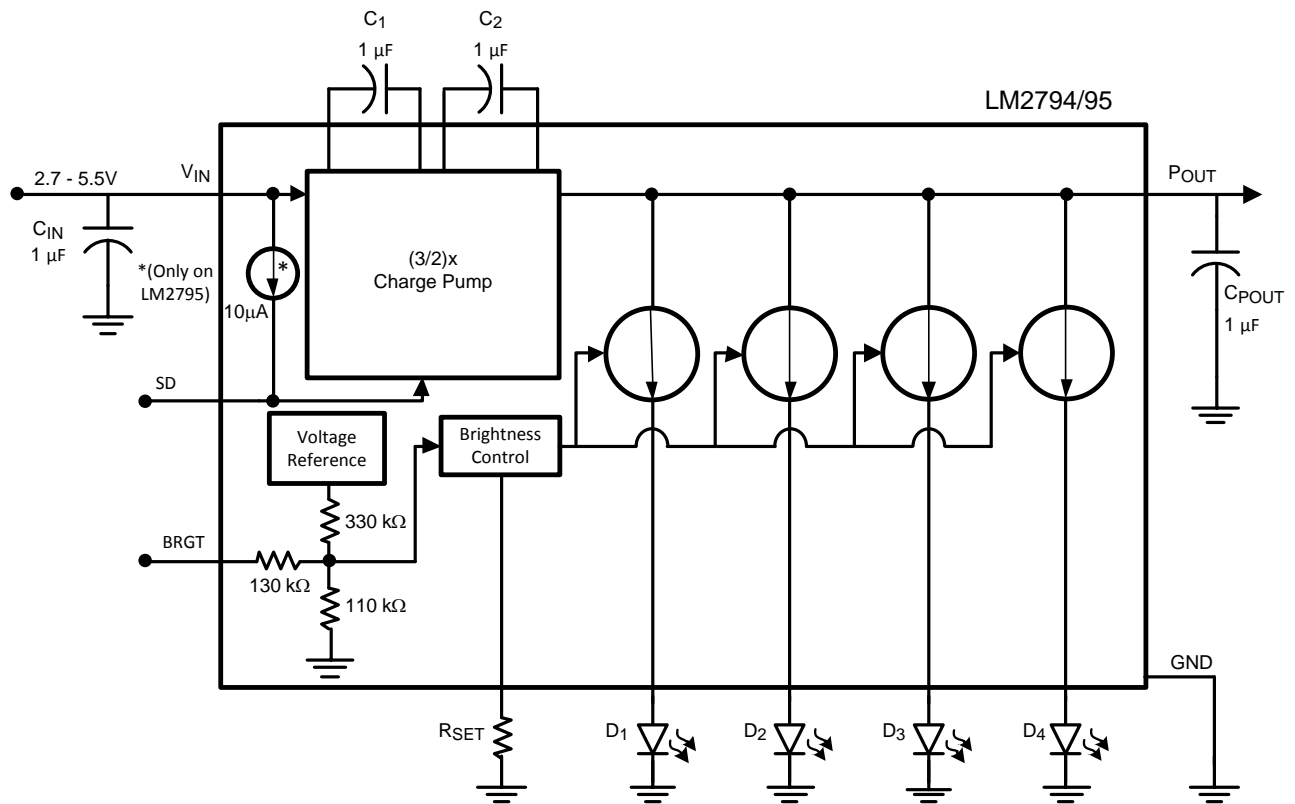

Figure 21.

FUNCTIONAL BLOCK DIAGRAM



## APPLICATION INFORMATION

### CIRCUIT DESCRIPTION

The LM2794/5 is a 1.5x/1x CMOS charge pump with four matched constant current outputs, each capable of driving up to 20mA through White LEDs. This device operates over the extended Li-Ion battery range from 2.7V to 5.5V. The LM2794/5 has four regulated current sources connected to the device's 1.5x charge pump output ( $P_{OUT}$ ). At input voltages below 4.7V (typ.), the charge-pump provides the needed voltage to drive high forward voltage drop White LEDs. It does this by stepping up the  $P_{OUT}$  voltage 1.5 times the input voltage. The charge pump operates in Pass Mode, providing a voltage on  $P_{OUT}$  equal to the input voltage, when the input voltage is at or above 4.7V (typ.). The device can drive up to 80mA through any combination of LEDs connected to the constant current outputs  $D_1$ - $D_4$ .

To set the LED drive current, the device uses a resistor connected to the  $I_{SET}$  pin to set a reference current. This reference current is then multiplied and mirrored to each constant current output. The LED brightness can then be controlled by analog and/or digital methods. Applying an analog voltage in the range of 0V to 3.0V to the Brightness pin (BRGT) adjusts the dimming profile of the LEDs. The digital technique uses a PWM (Pulse Width Modulation) signal applied to the Shutdown pin (SD). (see [I<sub>SET</sub> AND BRGT PINS](#)).

### SOFT START

Soft start is implemented internally by ramping the reference voltage more slowly than the applied voltage. During soft start, the current through the LED outputs will ramp up in proportion to the rate that the reference voltage is being ramped up.

### SHUTDOWN MODE

The shutdown pin (SD) disables the part and reduces the quiescent current to 2.3 $\mu$ A (typ.).

The LM2795 has an active-high shutdown pin (HIGH = shutdown, LOW = operating). An internal pull-up is connected between SD and  $V_{IN}$  of the LM2795. This allows the use of open-drain logic control of the LM2795 shutdown, as shown in [Figure 22](#). The LM2795 SD pin can also be driven with a rail-to-rail CMOS logic signal.

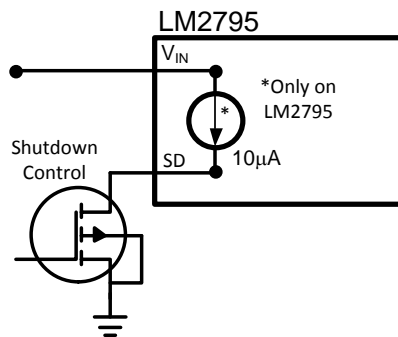

**Figure 22. Open-Drain Logic Shutdown Control**

The LM2794 has an active-low shutdown pin (LOW = shutdown, HIGH = operating). The LM2794 SD pin can be driven with a low-voltage CMOS logic signal (1.5V logic, 1.8V logic, etc). There is no internal pull-up or pull-down on the SD pin of the LM2794.

### CAPACITOR SELECTION

The LM2794/5 requires 4 external capacitors for proper operation. Surface-mount multi-layer ceramic capacitors are recommended. These capacitors are small, inexpensive and have very low equivalent series resistance (ESR,  $\leq 15m\Omega$  typ.). Tantalum capacitors, OS-CON capacitors, and aluminum electrolytic capacitors are generally not recommended for use with the LM2794/5 due to their high ESR, as compared to ceramic capacitors.

For most applications, ceramic capacitors with X7R or X5R temperature characteristic are preferred for use with the LM2794/5. These capacitors have tight capacitance tolerance (as good as  $\pm 10\%$ ), hold their value over temperature (X7R:  $\pm 15\%$  over  $-55^\circ\text{C}$  to  $125^\circ\text{C}$ ; X5R:  $\pm 15\%$  over  $-55^\circ\text{C}$  to  $85^\circ\text{C}$ ), and typically have little voltage coefficient. Capacitors with Y5V or Z5U temperature characteristic are generally not recommended for use with the LM2794/5. Capacitors with these temperature characteristics typically have wide capacitance tolerance ( $+80\%$ ,  $-20\%$ ), vary significantly over temperature (Y5V:  $+22\%$ ,  $-82\%$  over  $-30^\circ\text{C}$  to  $+85^\circ\text{C}$  range; Z5U:  $+22\%$ ,  $-56\%$  over  $+10^\circ\text{C}$  to  $+85^\circ\text{C}$  range), and have poor voltage coefficients. Under some conditions, a nominal  $1\mu\text{F}$  Y5V or Z5U capacitor could have a capacitance of only  $0.1\mu\text{F}$ . Such detrimental deviation is likely to cause Y5V and Z5U capacitors to fail to meet the minimum capacitance requirements of the LM2794/5. [Table 1](#) lists suggested capacitor suppliers for the typical application circuit.

**Table 1. Ceramic Capacitor Manufacturers**

Manufacturer	Contact
TDK	<a href="http://www.component.tdk.com">www.component.tdk.com</a>
Murata	<a href="http://www.murata.com">www.murata.com</a>
Taiyo Yuden	<a href="http://www.t-yuden.com">www.t-yuden.com</a>

## LED SELECTION

The LM2794/5 is designed to drive LEDs with a forward voltage of about 3.0V to 4.0V. The typical and maximum diode forward voltage depends highly on the manufacturer and their technology. [Table 2](#) lists two suggested manufacturers. Forward current matching is assured over the LED process variations due to the constant current output of the LM2794/5.

**Table 2. White LED Selection**

Manufacturer	Contact
Osram	<a href="http://www.osram-os.com">www.osram-os.com</a>
Nichia	<a href="http://www.nichia.com">www.nichia.com</a>

## I<sub>SET</sub> AND BRGT PINS

An external resistor,  $R_{\text{SET}}$ , is connected to the  $I_{\text{SET}}$  pin to set the current to be mirrored in each of the LED outputs. The internal current mirror sets each LED output current with a 10:1 ratio to the current through  $R_{\text{SET}}$ . The current mirror circuitry matches the current through each LED to within 0.5%.

In addition to  $R_{\text{SET}}$ , a voltage may be applied to the  $V_{\text{BRGT}}$  pin to vary the LED current. By adjusting current with the Brightness pin (BRGT), the brightness of the LEDs can be smoothly varied.

Applying a voltage on BRGT between 0 to 3 volts will linearly vary the LED current. Voltages above 3V do not increase the LED current any further. The voltage on the  $V_{\text{BRGT}}$  pin is fed into an internal resistor network with a ratio of 0.385. The resulting voltage is then summed with a measured offset voltage of 0.188V, which comes from the reference voltage being fed through a resistor network (See [Functional Block Diagram](#)). The brightness control circuitry then uses the summed voltage to control the voltage across  $R_{\text{SET}}$ . An equation for approximating the LED current is:

$$I_{\text{LED}} = \left( \frac{V_{\text{OFFSET}} + (V_{\text{BRGT}} * 0.385)}{R_{\text{SET}}} \right) * (\text{MirrorRatio})$$

$$I_{\text{LED}} = \left( \frac{0.188 + (V_{\text{BRGT}} * 0.385)}{R_{\text{SET}}} \right) * \frac{10}{1} \text{ Amps}$$

## I<sub>LED</sub> CURRENT SELECTION PROCEDURES

The following procedures illustrate how to set and adjust output current levels. For constant brightness or analog brightness control, go to “Brightness control using BRGT”. Otherwise refer to “Brightness control using PWM”.

### Brightness Control Using PWM

1. Set the BRGT pin to 0V.

- Determine the maximum desired  $I_{LED}$  current. Use the  $I_{LED}$  equation to calculate  $R_{SET}$  by setting BRGT to 0V or use [Table 3](#) to select a value for  $R_{SET}$  when BRGT equals 0V.
- Brightness control can be implemented by pulsing a signal at the SD pin. LED brightness is proportional to the duty cycle (D) of the PWM signal. For linear brightness control over the full duty cycle adjustment range, the PWM frequency (f) should be limited to accommodate the turn-on time ( $T_{ON} = 100\mu s$ ) of the device.

$$D \times (1/f) > T_{ON}$$

$$f_{MAX} = D_{MIN} \div T_{ON}$$

If the PWM frequency is much less than 100Hz, flicker may be seen in the LEDs. For the LM2794, zero duty cycle will turn off the LEDs and a 50% duty cycle will result in an average  $I_{LED}$  being half of the programmed LED current. For example, if  $R_{SET}$  is set to program 15mA, a 50% duty cycle will result in an average  $I_{LED}$  of 7.5mA. For the LM2795 however, 100% duty cycle will turn off the LEDs and a 50% duty cycle will result in an average  $I_{LED}$  being half the programmed LED current.

#### Brightness Control Using BRGT

- Choose the maximum  $I_{LED}$  desired and determine the max voltage to be applied to the BRGT pin. For constant brightness, set BRGT to a fixed voltage between 0V to 3V.
- Use [Table 3](#) to determine the value of  $R_{SET}$  required or use the  $I_{LED}$  equation above to calculate  $R_{SET}$ .
- Use [Table 4](#) as a reference for the dimming profile of the LEDs, when BRGT ranges from 0V to 3V.

**Table 3.  $R_{SET}$  Values**

BRGT	LED Current			
	5mA	10mA	15mA	20mA
0.0V	374Ω	187Ω	124Ω	93.1Ω
0.5V	768Ω	383Ω	255Ω	191Ω
1.0V	1.15KΩ	576Ω	383Ω	287Ω
1.5V	1.54KΩ	768Ω	511Ω	383Ω
2.0V	1.91KΩ	953Ω	624Ω	475Ω
2.5V	2.32KΩ	1.15KΩ	768Ω	576Ω
3.0V	2.67KΩ	1.33KΩ	909Ω	665Ω

**Table 4. LED Current**

BRGT	$R_{SET}$ Values			
	2.67KΩ	1.33KΩ	909Ω	665Ω
0.0V	0.7mA	1.4mA	2.1mA	2.8mA
0.5V	1.4mA	2.9mA	4.2mA	5.7mA
1.0V	2.1mA	4.3mA	6.3mA	8.6mA
1.5V	2.9mA	5.8mA	8.4mA	11.5mA
2.0V	3.6mA	7.2mA	10.5mA	14.4mA
2.5V	4.3mA	8.7mA	12.7mA	17.3mA
3.0V	5.0mA	10.1mA	14.8mA	20.2mA

#### CHARGE PUMP OUTPUT ( $P_{OUT}$ )

The LM2794/5 charge pump is an unregulated switched capacitor converter with a gain of 1.5. The voltage at the output of the pump (the  $P_{OUT}$  pin) is nominally  $1.5 \times V_{IN}$ . This rail can be used to deliver additional current to other circuitry. [Figure 23](#) shows how to connect additional LEDs to  $P_{OUT}$ . A ballast resistor sets the current through each LED, and LED current matching is dependent on the LED forward voltage matching. Because of this, LEDs driven by  $P_{OUT}$  are recommended for functions where brightness matching is not critical, such as keypad backlighting.

Since  $P_{OUT}$  is unregulated, driving LEDs directly off  $P_{OUT}$  is usually practical only with a fixed input voltage. If the input voltage is not fixed (Li-Ion battery, for example), using a linear regulator between the  $P_{OUT}$  pin and the LEDs is recommended. Texas Instruments LP3985-4.5V low-dropout linear regulator is a good choice for such an application.

The voltage at P<sub>OUT</sub> is dependent on the input voltage supplied to the LM2794/5, the total LM2794/5 output current, and the output resistance (R<sub>OUT</sub>) of the LM2794/5 charge pump. Output resistance is a model of the switching losses of the charge pump. Resistances of the internal charge pump switches (MOS transistors) are a primary component of the LM2794/5 output resistance. Typical LM2794/5 output resistance is 3.0Ω. For worst-case design calculations, using an output resistance of 3.5Ω is recommended. (Worst-case recommendation accounts for parameter shifts from part-to-part variation and applies over the full operating temperature range).

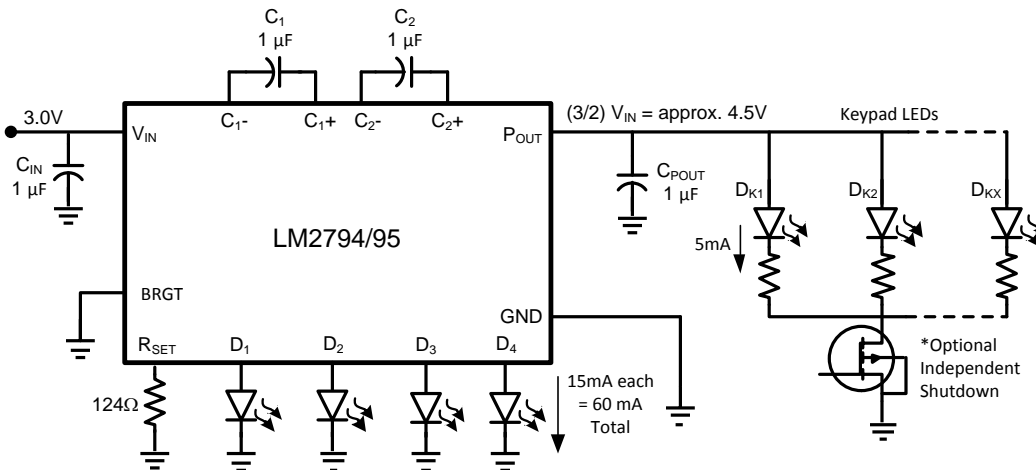

Figure 23. Keypad LEDs Connected to P<sub>OUT</sub>

Output resistance results in droop in the P<sub>OUT</sub> voltage proportional to the amount of current delivered by the pump. The P<sub>OUT</sub> voltage is an important factor in determining the total output current capability of an application. Taking total output current to be the sum of all D<sub>X</sub> output currents plus the current delivered through the P<sub>OUT</sub> pin, the voltage at P<sub>OUT</sub> can be predicted with the following equations:

$$I_{TOTAL} = I_{D1} + I_{D2} + I_{D3} + I_{D4} + I_{POUT} \quad (1)$$

$$V_{POUT} = 1.5 \times V_{IN} - I_{TOTAL} \times R_{OUT} \quad (2)$$

### LED HEADROOM VOLTAGE (V<sub>HR</sub>)

Four current sources are connected internally between P<sub>OUT</sub> and D<sub>1</sub>-D<sub>4</sub>. The voltage across each current source, (V<sub>POUT</sub> - V<sub>DX</sub>), is referred to as headroom voltage (V<sub>HR</sub>). The current sources require a sufficient amount of headroom voltage to be present across them in order to regulate properly. Minimum required headroom voltage is proportional to the current flowing through the current source, as dictated by the equation:

$$V_{HR-MIN} = k_{HR} \times I_{DX} \quad (3)$$

The parameter k<sub>HR</sub>, typically 20mV/mA in the LM2794/5, is a proportionality constant that represents the ON-resistance of the internal current mirror transistors. For worst-case design calculations, using a k<sub>HR</sub> of 25mV/mA is recommended. (Worst-case recommendation accounts for parameter shifts from part-to-part variation and applies over the full operating temperature range). Figure 24 shows how output current of the LM2794/5 varies with respect to headroom voltage.

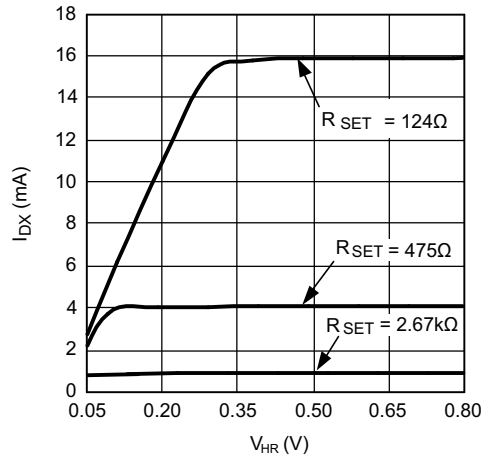

**Figure 24.  $I_{LED}$  vs  $V_{HR}$**   
4 LEDs,  $V_{IN} = 3.0V$

On the flat part of the graph, the currents regulate properly as there is sufficient headroom voltage for regulation. On the sloping part of the graph the headroom voltage is too small, the current sources are squeezed, and their current drive capability is limited. Changes in headroom voltage from one output to the next, possible with LED forward voltage mismatch, will result in different output currents and LED brightness mismatch. Thus, operating the LM2794/5 with insufficient headroom voltage across the current sources should be avoided.

## OUTPUT CURRENT CAPABILITY

The primary constraint on the total current capability is the headroom voltage requirement of the internal current sources. Combining the  $V_{POUT}$  and  $V_{HR}$  equations from the previous two sections yields the basic inequality for determining the validity of an LM2794/5 LED-drive application:

$$V_{POUT} = 1.5 \times V_{IN} - I_{TOTAL} \times R_{OUT} \quad (4)$$

$$V_{HR-MIN} = k_{HR} \times I_{DX} \quad (5)$$

$$V_{POUT} - V_{DX} \geq V_{HR-MIN} \quad (6)$$

$$1.5 \times V_{IN} - I_{TOTAL} \times R_{OUT} - V_{DX} \geq (k_{HR} \times I_{DX}) \quad (7)$$

Rearranging this inequality shows the estimated total output current capability of an application:

$$I_{TOTAL} \leq [(1.5 \times V_{IN-MIN}) - V_{DX-MAX} - (k_{HR} \times I_{DX})] \div R_{OUT} \quad (8)$$

Examining the equation above, the primary limiting factors on total output current capability are input and LED forward voltage. A low input voltage combined with a high LED voltage may result in insufficient headroom voltage across the current sources, causing them to fall out of regulation. When the current sources are not regulated, LED currents will be below desired levels and brightness matching will be highly dependent on LED forward voltage matching.

Typical LM2794/5 output resistance is  $3.0\Omega$ . For worst-case design calculations, using an output resistance of  $3.5\Omega$  is recommended. LM2794/5 has a typical  $k_{HR}$  constant of  $20\text{mV}/\text{mA}$ . For worst-case design calculations, use  $k_{HR} = 25\text{mV}/\text{mA}$ . (Worst-case recommendations account for parameter shifts from part-to-part variation and apply over the full operating temperature range).  $R_{OUT}$  and  $k_{HR}$  increase slightly with temperature, but losses are typically offset by the negative temperature coefficient properties of LED forward voltages. Power dissipation and internal self-heating may also limit output current capability but is discussed in a later section.

## PARALLEL Dx OUTPUTS FOR INCREASED CURRENT DRIVE

Outputs  $D_1$  through  $D_4$  may be connected together in any combination to drive higher currents through fewer LEDs. For example in [Figure 25](#), outputs  $D_1$  and  $D_2$  are connected together to drive one LED while  $D_3$  and  $D_4$  are connected together to drive a second LED.

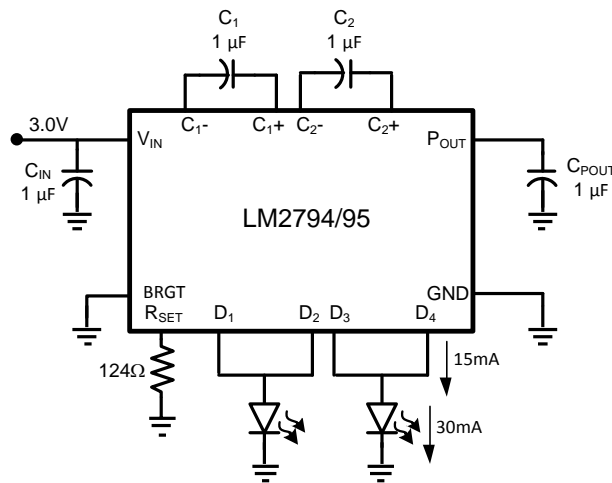

Figure 25. Two Parallel Connected LEDs

With this configuration, two parallel current sources of equal value provide current to each LED.  $R_{SET}$  and  $V_{BRGT}$  should therefore be chosen so that the current through each output is programmed to 50% of the desired current through the parallel connected LEDs. For example, if 30mA is the desired drive current for 2 parallel connected LEDs,  $R_{SET}$  and  $V_{BRGT}$  should be selected so that the current through each of the outputs is 15mA. Other combinations of parallel outputs may be implemented in similar fashions, such as in [Figure 26](#).

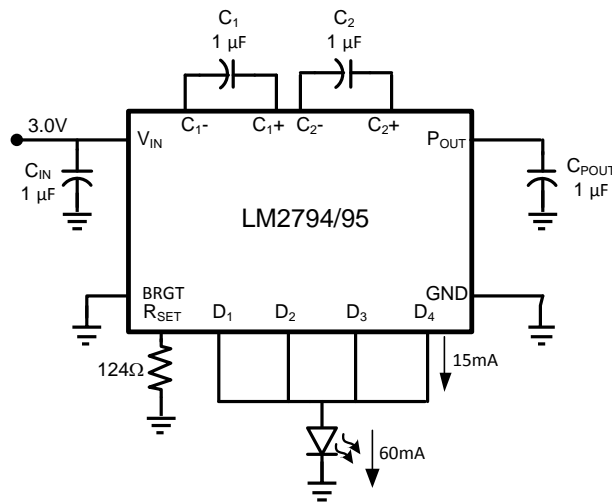

Figure 26. One Parallel Connected LED

Connecting outputs in parallel does not affect internal operation of the LM2794/95 and has no impact on the Electrical Characteristics and limits previously presented. The available diode output current, maximum diode voltage, and all other specifications provided in the [Electrical Characteristics](#) table apply to parallel output configurations, just as they do to the standard 4-LED application circuit.

## THERMAL PROTECTION

When the junction temperature exceeds 150°C (typ.), the LM2794/5 internal thermal protection circuitry disables the part. This feature protects the device from damage due to excessive power dissipation. The device will recover and operate normally when the junction temperature falls below 140°C (typ.). It is important to have good thermal conduction with a proper layout to reduce thermal resistance.

## POWER EFFICIENCY

Figure 27 shows the efficiency of the LM2794/5. The change in efficiency shown by the graph comes from the transition from Pass Mode to a gain of 1.5.

Efficiency (E) of the LM2794/5 is defined here as the ratio of the power consumed by LEDs ( $P_{LED}$ ) to the power drawn from the input source ( $P_{IN}$ ). In the equations below,  $I_Q$  is the quiescent current of the LM2794/5,  $I_{LED}$  is the current flowing through one LED,  $V_{LED}$  is the forward voltage at that LED current, and N is the number of LEDs connected to the regulated current outputs. In the input power calculation, the 1.5 represents the switched capacitor gain configuration of the LM2794/5.

$$P_{LED} = N \times V_{LED} \times I_{LED} \quad (9)$$

$$P_{IN} = V_{IN} \times I_{IN} \quad (10)$$

$$P_{IN} = V_{IN} \times (1.5 \times N \times I_{LED} + I_Q) \quad (11)$$

$$E = (P_{LED} \div P_{IN}) \quad (12)$$

Efficiency, as defined here, is in part dependent on LED voltage. Variation in LED voltage does not affect power consumed by the circuit and typically does not relate to the brightness of the LED. For an advanced analysis, it is recommended that power consumed by the circuit ( $V_{IN} \times I_{IN}$ ) be evaluated rather than power efficiency. Figure 28 shows the power consumption of the LM2794/5 Typical Application Circuit.

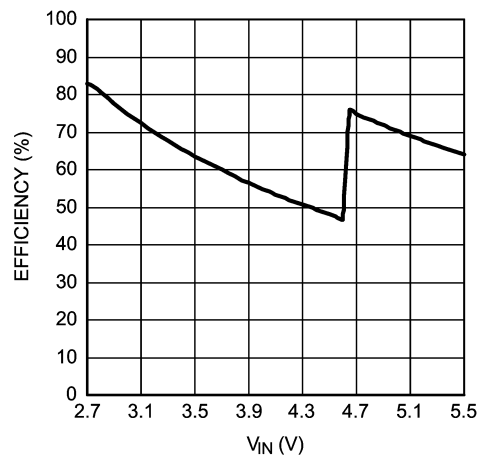

**Figure 27. Efficiency vs V<sub>IN</sub>**  
4 LEDs, V<sub>LED</sub> = 3.6V, I<sub>LED</sub> = 15mA

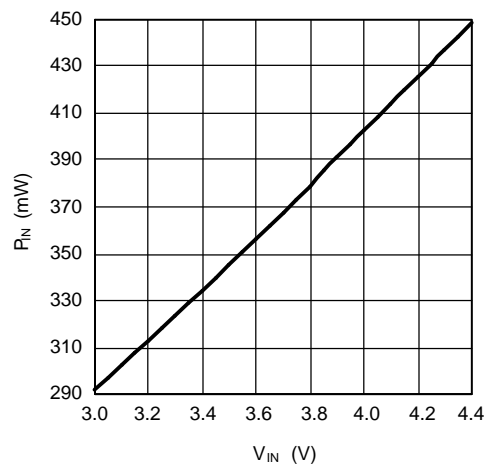

**Figure 28. P<sub>IN</sub> vs V<sub>IN</sub>**  
4 LEDs, 2.5 ≤ V<sub>DX</sub> ≤ 3.9V, I<sub>DX</sub> = 15mA

## POWER DISSIPATION

The power dissipation ( $P_{\text{DISSIPATION}}$ ) and junction temperature ( $T_J$ ) can be approximated with the equations below.  $P_{\text{IN}}$  is the power generated by the 1.5x charge pump,  $P_{\text{LED}}$  is the power consumed by the LEDs,  $P_{\text{POUT}}$  is the power provided through the  $P_{\text{OUT}}$  pin,  $T_A$  is the ambient temperature, and  $\theta_{JA}$  is the junction-to-ambient thermal resistance for the DSBGA package.  $V_{\text{IN}}$  is the input voltage to the LM2794/5,  $V_{\text{DX}}$  is the LED forward voltage,  $I_{\text{DX}}$  is the programmed LED current, and  $I_{\text{POUT}}$  is the current drawn through  $P_{\text{OUT}}$ .

$$P_{\text{DISSIPATION}} = P_{\text{IN}} - P_{\text{LED}} - P_{\text{POUT}} \quad (13)$$

$$= [1.5 \times V_{\text{IN}} \times (4I_{\text{DX}} + I_{\text{POUT}})] - (V_{\text{DX}} \times 4I_{\text{DX}}) - (1.5 \times V_{\text{IN}} \times I_{\text{POUT}}) \quad (14)$$

$$T_J = T_A + (P_{\text{DISSIPATION}} \times \theta_{JA}) \quad (15)$$

The junction temperature rating takes precedence over the ambient temperature rating. The LM2794/5 may be operated outside the ambient temperature rating, so long as the junction temperature of the device does not exceed the maximum operating rating of 100°C. The maximum ambient temperature rating must be derated in applications where high power dissipation and/or poor thermal resistance causes the junction temperature to exceed 100°C.

## DSBGA MOUNTING

The LM2794/5 is a 14-bump DSBGA with a bump size of 300 micron diameter. The DSBGA package requires specific mounting techniques detailed in Application Note (AN -1112 [SNVA009](#)). NSMD (non-solder mask defined) layout pattern is recommended over the SMD (solder mask defined) since the NSMD requires larger solder mask openings over the pad size as opposed to the SMD. This reduces stress on the PCB and prevents possible cracking at the solder joint. For best results during assembly, alignment ordinals on the PC board should be used to facilitate placement of the DSBGA device. DSBGA is a wafer level chip size package, which means the dimensions of the package are equal to the die size. As such, the DSBGA package lacks the plastic encapsulation characteristics of the larger devices and is sensitive to direct exposure to light sources such as infrared, halogen, and sun light. The wavelengths of these light sources may cause unpredictable operation.

## REVISION HISTORY

Changes from Revision K (May 2013) to Revision L	Page
• Changed layout of National Data Sheet to TI format .....	<a href="#">17</a>

**PACKAGING INFORMATION**

Orderable Device	Status (1)	Package Type	Package Drawing	Pins	Package Qty	Eco Plan (2)	Lead/Ball Finish (6)	MSL Peak Temp (3)	Op Temp (°C)	Device Marking (4/5)	Samples
LM2794TL/NOPB	ACTIVE	DSBGA	YPA	14	250	Green (RoHS & no Sb/Br)	SNAGCU	Level-1-260C-UNLIM	-30 to 85	LOG	

(1) The marketing status values are defined as follows:

**ACTIVE:** Product device recommended for new designs.

**LIFEBUY:** TI has announced that the device will be discontinued, and a lifetime-buy period is in effect.

**NRND:** Not recommended for new designs. Device is in production to support existing customers, but TI does not recommend using this part in a new design.

**PREVIEW:** Device has been announced but is not in production. Samples may or may not be available.

**OBSOLETE:** TI has discontinued the production of the device.

(2) Eco Plan - The planned eco-friendly classification: Pb-Free (RoHS), Pb-Free (RoHS Exempt), or Green (RoHS & no Sb/Br) - please check <http://www.ti.com/productcontent> for the latest availability information and additional product content details.

**TBD:** The Pb-Free/Green conversion plan has not been defined.

**Pb-Free (RoHS):** TI's terms "Lead-Free" or "Pb-Free" mean semiconductor products that are compatible with the current RoHS requirements for all 6 substances, including the requirement that lead not exceed 0.1% by weight in homogeneous materials. Where designed to be soldered at high temperatures, TI Pb-Free products are suitable for use in specified lead-free processes.

**Pb-Free (RoHS Exempt):** This component has a RoHS exemption for either 1) lead-based flip-chip solder bumps used between the die and package, or 2) lead-based die adhesive used between the die and leadframe. The component is otherwise considered Pb-Free (RoHS compatible) as defined above.

**Green (RoHS & no Sb/Br):** TI defines "Green" to mean Pb-Free (RoHS compatible), and free of Bromine (Br) and Antimony (Sb) based flame retardants (Br or Sb do not exceed 0.1% by weight in homogeneous material)

(3) MSL, Peak Temp. - The Moisture Sensitivity Level rating according to the JEDEC industry standard classifications, and peak solder temperature.

(4) There may be additional marking, which relates to the logo, the lot trace code information, or the environmental category on the device.

(5) Multiple Device Markings will be inside parentheses. Only one Device Marking contained in parentheses and separated by a "~" will appear on a device. If a line is indented then it is a continuation of the previous line and the two combined represent the entire Device Marking for that device.

(6) Lead/Ball Finish - Orderable Devices may have multiple material finish options. Finish options are separated by a vertical ruled line. Lead/Ball Finish values may wrap to two lines if the finish value exceeds the maximum column width.

**Important Information and Disclaimer:** The information provided on this page represents TI's knowledge and belief as of the date that it is provided. TI bases its knowledge and belief on information provided by third parties, and makes no representation or warranty as to the accuracy of such information. Efforts are underway to better integrate information from third parties. TI has taken and continues to take reasonable steps to provide representative and accurate information but may not have conducted destructive testing or chemical analysis on incoming materials and chemicals. TI and TI suppliers consider certain information to be proprietary, and thus CAS numbers and other limited information may not be available for release.

In no event shall TI's liability arising out of such information exceed the total purchase price of the TI part(s) at issue in this document sold by TI to Customer on an annual basis.



## TAPE AND REEL INFORMATION



### QUADRANT ASSIGNMENTS FOR PIN 1 ORIENTATION IN TAPE



\*All dimensions are nominal

Device	Package Type	Package Drawing	Pins	SPQ	Reel Diameter (mm)	Reel Width W1 (mm)	A0 (mm)	B0 (mm)	K0 (mm)	P1 (mm)	W (mm)	Pin1 Quadrant
LM2794TL/NOPB	DSBGA	YPA	14	250	178.0	8.4	2.29	2.59	0.76	4.0	8.0	Q1

TAPE AND REEL BOX DIMENSIONS



\*All dimensions are nominal

Device	Package Type	Package Drawing	Pins	SPQ	Length (mm)	Width (mm)	Height (mm)
LM2794TL/NOPB	DSBGA	YPA	14	250	210.0	185.0	35.0

YPA0014

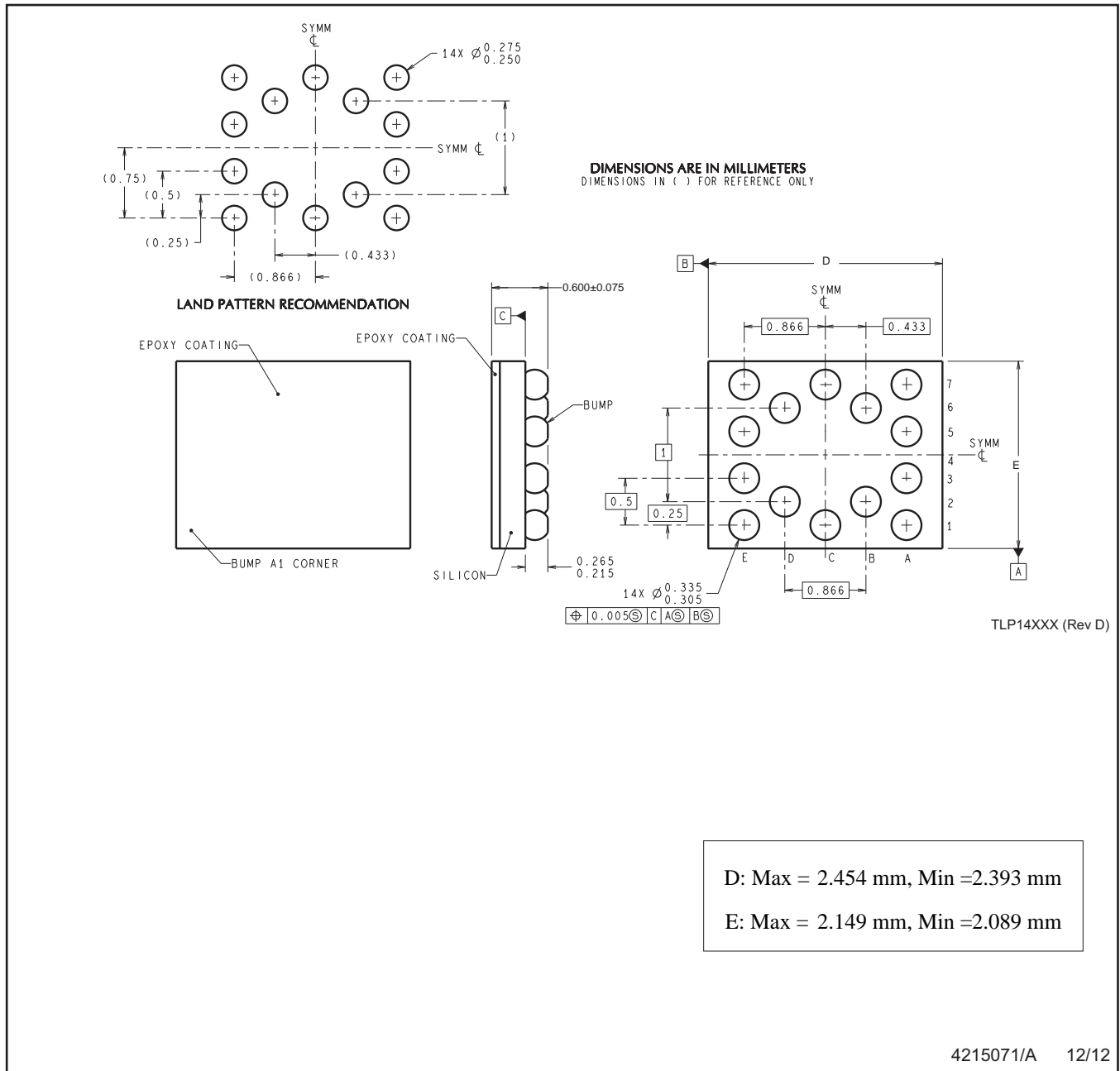

NOTES: A. All linear dimensions are in millimeters. Dimensioning and tolerancing per ASME Y14.5M-1994.  
B. This drawing is subject to change without notice.

4215071/A 12/12

## IMPORTANT NOTICE

Texas Instruments Incorporated (TI) reserves the right to make corrections, enhancements, improvements and other changes to its semiconductor products and services per JESD46, latest issue, and to discontinue any product or service per JESD48, latest issue. Buyers should obtain the latest relevant information before placing orders and should verify that such information is current and complete.

TI's published terms of sale for semiconductor products (<http://www.ti.com/sc/docs/stdterms.htm>) apply to the sale of packaged integrated circuit products that TI has qualified and released to market. Additional terms may apply to the use or sale of other types of TI products and services.

Reproduction of significant portions of TI information in TI data sheets is permissible only if reproduction is without alteration and is accompanied by all associated warranties, conditions, limitations, and notices. TI is not responsible or liable for such reproduced documentation. Information of third parties may be subject to additional restrictions. Resale of TI products or services with statements different from or beyond the parameters stated by TI for that product or service voids all express and any implied warranties for the associated TI product or service and is an unfair and deceptive business practice. TI is not responsible or liable for any such statements.

Buyers and others who are developing systems that incorporate TI products (collectively, "Designers") understand and agree that Designers remain responsible for using their independent analysis, evaluation and judgment in designing their applications and that Designers have full and exclusive responsibility to assure the safety of Designers' applications and compliance of their applications (and of all TI products used in or for Designers' applications) with all applicable regulations, laws and other applicable requirements. Designer represents that, with respect to their applications, Designer has all the necessary expertise to create and implement safeguards that (1) anticipate dangerous consequences of failures, (2) monitor failures and their consequences, and (3) lessen the likelihood of failures that might cause harm and take appropriate actions. Designer agrees that prior to using or distributing any applications that include TI products, Designer will thoroughly test such applications and the functionality of such TI products as used in such applications.

TI's provision of technical, application or other design advice, quality characterization, reliability data or other services or information, including, but not limited to, reference designs and materials relating to evaluation modules, (collectively, "TI Resources") are intended to assist designers who are developing applications that incorporate TI products; by downloading, accessing or using TI Resources in any way, Designer (individually or, if Designer is acting on behalf of a company, Designer's company) agrees to use any particular TI Resource solely for this purpose and subject to the terms of this Notice.

TI's provision of TI Resources does not expand or otherwise alter TI's applicable published warranties or warranty disclaimers for TI products, and no additional obligations or liabilities arise from TI providing such TI Resources. TI reserves the right to make corrections, enhancements, improvements and other changes to its TI Resources. TI has not conducted any testing other than that specifically described in the published documentation for a particular TI Resource.

Designer is authorized to use, copy and modify any individual TI Resource only in connection with the development of applications that include the TI product(s) identified in such TI Resource. NO OTHER LICENSE, EXPRESS OR IMPLIED, BY ESTOPPEL OR OTHERWISE TO ANY OTHER TI INTELLECTUAL PROPERTY RIGHT, AND NO LICENSE TO ANY TECHNOLOGY OR INTELLECTUAL PROPERTY RIGHT OF TI OR ANY THIRD PARTY IS GRANTED HEREIN, including but not limited to any patent right, copyright, mask work right, or other intellectual property right relating to any combination, machine, or process in which TI products or services are used. Information regarding or referencing third-party products or services does not constitute a license to use such products or services, or a warranty or endorsement thereof. Use of TI Resources may require a license from a third party under the patents or other intellectual property of the third party, or a license from TI under the patents or other intellectual property of TI.

TI RESOURCES ARE PROVIDED "AS IS" AND WITH ALL FAULTS. TI DISCLAIMS ALL OTHER WARRANTIES OR REPRESENTATIONS, EXPRESS OR IMPLIED, REGARDING RESOURCES OR USE THEREOF, INCLUDING BUT NOT LIMITED TO ACCURACY OR COMPLETENESS, TITLE, ANY EPIDEMIC FAILURE WARRANTY AND ANY IMPLIED WARRANTIES OF MERCHANTABILITY, FITNESS FOR A PARTICULAR PURPOSE, AND NON-INFRINGEMENT OF ANY THIRD PARTY INTELLECTUAL PROPERTY RIGHTS. TI SHALL NOT BE LIABLE FOR AND SHALL NOT DEFEND OR INDEMNIFY DESIGNER AGAINST ANY CLAIM, INCLUDING BUT NOT LIMITED TO ANY INFRINGEMENT CLAIM THAT RELATES TO OR IS BASED ON ANY COMBINATION OF PRODUCTS EVEN IF DESCRIBED IN TI RESOURCES OR OTHERWISE. IN NO EVENT SHALL TI BE LIABLE FOR ANY ACTUAL, DIRECT, SPECIAL, COLLATERAL, INDIRECT, PUNITIVE, INCIDENTAL, CONSEQUENTIAL OR EXEMPLARY DAMAGES IN CONNECTION WITH OR ARISING OUT OF TI RESOURCES OR USE THEREOF, AND REGARDLESS OF WHETHER TI HAS BEEN ADVISED OF THE POSSIBILITY OF SUCH DAMAGES.

Unless TI has explicitly designated an individual product as meeting the requirements of a particular industry standard (e.g., ISO/TS 16949 and ISO 26262), TI is not responsible for any failure to meet such industry standard requirements.

Where TI specifically promotes products as facilitating functional safety or as compliant with industry functional safety standards, such products are intended to help enable customers to design and create their own applications that meet applicable functional safety standards and requirements. Using products in an application does not by itself establish any safety features in the application. Designers must ensure compliance with safety-related requirements and standards applicable to their applications. Designer may not use any TI products in life-critical medical equipment unless authorized officers of the parties have executed a special contract specifically governing such use. Life-critical medical equipment is medical equipment where failure of such equipment would cause serious bodily injury or death (e.g., life support, pacemakers, defibrillators, heart pumps, neurostimulators, and implantables). Such equipment includes, without limitation, all medical devices identified by the U.S. Food and Drug Administration as Class III devices and equivalent classifications outside the U.S.

TI may expressly designate certain products as completing a particular qualification (e.g., Q100, Military Grade, or Enhanced Product). Designers agree that it has the necessary expertise to select the product with the appropriate qualification designation for their applications and that proper product selection is at Designers' own risk. Designers are solely responsible for compliance with all legal and regulatory requirements in connection with such selection.

Designer will fully indemnify TI and its representatives against any damages, costs, losses, and/or liabilities arising out of Designer's non-compliance with the terms and provisions of this Notice.

## Looking for pricing, stock, or lifecycle information?

Click below to explore more details on WIN SOURCE:

 [View LM2795TL](#) on WIN SOURCE

 [Texas Instruments](#) Information

## Optimize Your Supply Chain with WIN SOURCE Solutions

-  Global Sourcing Solution
-  Obsolete Management
-  Cost Control Management
-  Shortage Management
-  Alternative Solution
-  Excess Inventory Management