



THE DATASHEET OF LM27951SDX/NOPB



LM27951 White LED Adaptive 1.5x/1x Switched-Capacitor Current Driver

1 Features

- Input Voltage Range: 2.8 V to 5.5 V
- Drives up to Four LEDs With up to 30 mA each
- Regulated Current Sources with 0.2% (Typical) Matching
- 3/2x, 1x Gain Transition Based on LED V_f
- Peak Efficiency Over 85%
- PWM Brightness Control
- Very Small Solution Size - No Inductor
- Fixed 750-kHz Switching Frequency
- < 1- μ A Shutdown Current

2 Applications

- White LED Display Backlights
- White LED Keypad Backlights
- General Purpose LED Lighting

3 Description

The LM27951 is a switched capacitor white-LED driver capable of driving up to four LEDs with 30 mA through each LED. Its four tightly regulated current sources ensure excellent LED current and brightness matching. LED drive current is programmed by an external sense resistor. The LM27951 operates over an input voltage range from 2.8 V to 5.5 V and requires only four low-cost ceramic capacitors.

The LM27951 provides excellent efficiency without the use of an inductor by operating the charge pump in a gain of 3/2, or in a gain of 1. Maximum efficiency is achieved over the input voltage range by actively selecting the proper gain based on the LED forward voltage requirements.

The LM27951 uses constant frequency pre-regulation to minimize conducted noise on the input. It has a fixed 750-kHz switching frequency optimized for portable applications. The LM27951 consumes less than 1 μ A of supply current when shut down.

The LM27951 is available in a 14-pin no-pullback WSON package.

Device Information⁽¹⁾

PART NUMBER	PACKAGE	BODY SIZE (NOM)
LM27951	WSON (14)	4.00 mm x 3.00 mm

(1) For all available packages, see the orderable addendum at the end of the data sheet.

Simplified Schematic

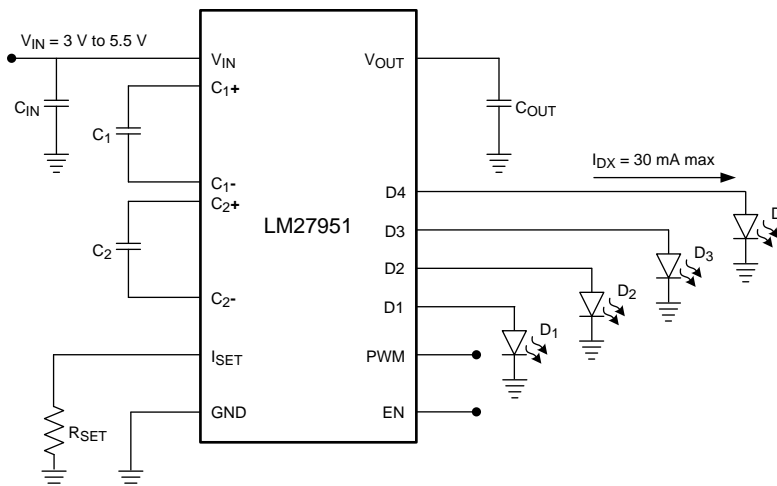

Table of Contents

1 Features 1 2 Applications 1 3 Description 1 4 Revision History 2 5 Pin Configuration and Functions 3 6 Specifications 4 6.1 Absolute Maximum Ratings 4 6.2 ESD Ratings 4 6.3 Recommended Operating Conditions 4 6.4 Thermal Information 4 6.5 Electrical Characteristics 5 6.6 Typical Characteristics 6 7 Detailed Description 7 7.1 Overview 7 7.2 Functional Block Diagram 7 7.3 Feature Description 7	7.4 Device Functional Modes 8 8 Application and Implementation 9 8.1 Application Information 9 8.2 Typical Application 10 9 Power Supply Recommendations 12 10 Layout 13 10.1 Layout Guidelines 13 10.2 Layout Example 13 11 Device and Documentation Support 14 11.1 Device Support 14 11.2 Documentation Support 14 11.3 Community Resources 14 11.4 Trademarks 14 11.5 Electrostatic Discharge Caution 14 11.6 Glossary 14 12 Mechanical, Packaging, and Orderable Information 14
---	--

4 Revision History

NOTE: Page numbers for previous revisions may differ from page numbers in the current version.

Changes from Revision B (May 2013) to Revision C	Page
<ul style="list-style-type: none"> • Added <i>Device Information</i> and <i>Pin Configuration and Functions</i> sections, <i>ESD Ratings</i> and <i>Thermal Information</i> tables, <i>Feature Description</i>, <i>Device Functional Modes</i>, <i>Application and Implementation</i>, <i>Power Supply Recommendations</i>, <i>Layout</i>, <i>Device and Documentation Support</i>, and <i>Mechanical, Packaging, and Orderable Information</i> sections..... 	1

Changes from Revision A (May 2013) to Revision B	Page
<ul style="list-style-type: none"> • Changed layout of National Data Sheet to TI format 	13

5 Pin Configuration and Functions

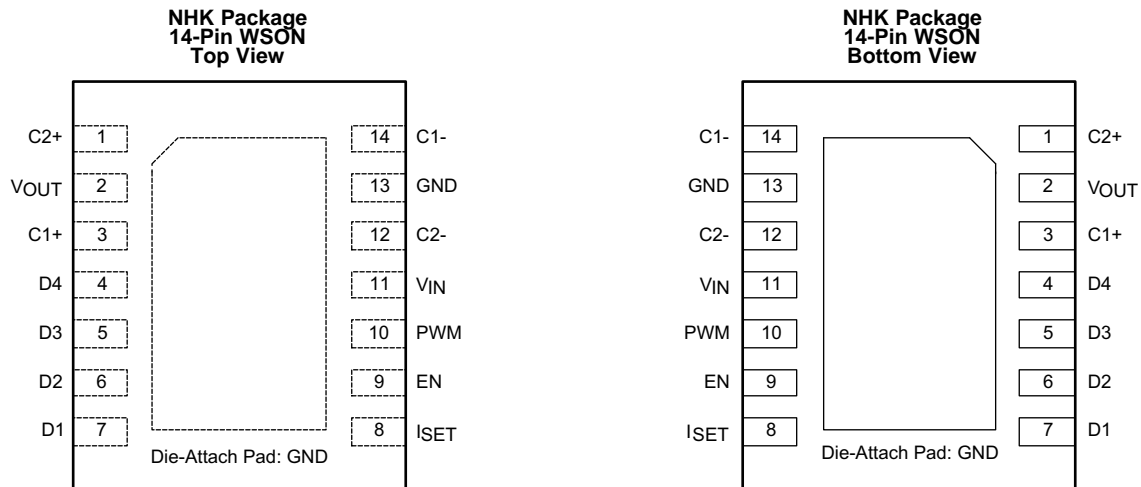

Pin Functions

PIN		TYPE	DESCRIPTION
NUMBER	NAME		
1	C2+	Power	Flying capacitor C2 connection
2	V _{OUT}	Power	Pre-regulated charge-pump output
3	C1+	Power	Flying capacitor C1 connection
4	D4	Output	Regulated current source output
5	D3	Output	Regulated current source output
6	D2	Output	Regulated current source output
7	D1	Output	Regulated current source output
8	I _{SET}	Input	Current set input. Placing a resistor (R _{SET}) between this pin and GND sets the LED current for all the LEDs. LED current = 200 × (1.25 V / R _{SET}).
9	EN	Input	Enable logic input pin. Logic low = shutdown; Logic high = enabled. There is a 150-kΩ (typical) resistor connected internally between the EN pin and GND.
10	PWM	Input	Current source modulation logic input pin. Logic low = Off; Logic high = On. Applying a pulse width modulated (PWM) signal to this pin allows the regulated current sources to be modulated without shutting down the internal charge pump and the V _{OUT} node.
11	V _{IN}	Input	Input supply: 2.8 V to 5.5 V
12	C2-	Power	Flying capacitor C2 connection
13	GND	Ground	Power supply ground connection
14	C1-	Power	Flying capacitor C1 connection

6 Specifications

6.1 Absolute Maximum Ratings

over operating free-air temperature range (unless otherwise noted)⁽¹⁾⁽²⁾

	MIN	MAX	UNIT
V_{IN}	-0.3	6	V
EN, PWM	-0.3	$V_{IN} + 0.3^{(3)}$	V
Continuous power dissipation	Internally limited		
Junction temperature, $T_{J-MAX-ABS}$		150	°C
Lead temperature (Soldering, 5 sec.)		260	°C
Storage temperature, T_{stg}	-65	150	°C

- (1) Stresses beyond those listed under *Absolute Maximum Ratings* may cause permanent damage to the device. These are stress ratings only, which do not imply functional operation of the device at these or any other conditions beyond those indicated under *Recommended Operating Conditions*. Exposure to absolute-maximum-rated conditions for extended periods may affect device reliability.
- (2) If Military/Aerospace specified devices are required, contact the Texas Instruments Sales Office / Distributors for availability and specifications.
- (3) Maximum value is 6 V.

6.2 ESD Ratings

	VALUE	UNIT
$V_{(ESD)}$ Electrostatic discharge Human-body model (HBM), per ANSI/ESDA/JEDEC JS-001 ⁽¹⁾	±2000	V

- (1) JEDEC document JEP155 states that 500-V HBM allows safe manufacturing with a standard ESD control process.

6.3 Recommended Operating Conditions

over operating free-air temperature range (unless otherwise noted)⁽¹⁾⁽²⁾⁽³⁾

	MIN	NOM	MAX	UNIT
Input voltage, V_{IN}	2.8		5.5	V
LED voltage	2.5		3.9	V
Junction temperature, T_J	-40		115	°C
Ambient temperature, T_A	-40		85	°C

- (1) All voltages are with respect to the potential at the GND pin.
- (2) Minimum and maximum limits are ensured by design, test, or statistical analysis. Typical numbers are not ensured, but do represent the most likely norm.
- (3) In applications where high power dissipation and/or poor package thermal resistance is present, the maximum ambient temperature may have to be derated. Maximum ambient temperature (T_{A-MAX}) is dependent on the maximum operation junction temperature ($T_{J-MAX-OP} = 115^\circ\text{C}$), the maximum power dissipation of the device in the application (P_{D-MAX}), and the junction-to ambient thermal resistance of the part/package in the application ($R_{\theta JA}$), as given by the equation: $T_{A-MAX} = T_{J-MAX-OP} - (R_{\theta JA} \times P_{D-MAX})$.

6.4 Thermal Information

THERMAL METRIC ⁽¹⁾	LM27951	UNIT
	NHK (WSON)	
	14 PINS	
$R_{\theta JA}$ Junction-to-ambient thermal resistance	42.5	°C/W
$R_{\theta JC(top)}$ Junction-to-case (top) thermal resistance	33.3	°C/W
$R_{\theta JB}$ Junction-to-board thermal resistance	14.1	°C/W
Ψ_{JT} Junction-to-top characterization parameter	0.5	°C/W
Ψ_{JB} Junction-to-board characterization parameter	14.1	°C/W
$R_{\theta JC(bot)}$ Junction-to-case (bottom) thermal resistance	6.1	°C/W

- (1) For more information about traditional and new thermal metrics, see the *Semiconductor and IC Package Thermal Metrics* application report, [SPRA953](#).

6.5 Electrical Characteristics

Unless otherwise noted, typical limits are for $T_A = 25^\circ\text{C}$, and minimum and maximum limits apply over the full operating temperature (-40°C to $+85^\circ\text{C}$); specifications apply to the *Simplified Schematic* with $V_{IN} = 3.6\text{ V}$, $V(\text{EN}) = 1.8\text{ V}$, $V(\text{PWM}) = 1.8\text{ V}$, 4 LEDs, $V_{DX} = 3.6\text{ V}$, $C_{IN} = C_{OUT} = 3.3\text{ }\mu\text{F}$, $C_1 = C_2 = 1\text{ }\mu\text{F}$, $R_{SET} = 12.5\text{ k}\Omega$ ^{(1) (2)}.

PARAMETER	TEST CONDITIONS	MIN	TYP	MAX	UNIT	
I_{DX}	LED current regulation	$3\text{ V} \leq V_{IN} \leq 5.5\text{ V}$ $R_{SET} = 12.5\text{ k}\Omega$ $I_{VOUT} = 0\text{ mA}$	18.4 (-8%)	20	21.6 (8%)	mA
		$3\text{ V} \leq V_{IN} \leq 5.5\text{ V}$ $R_{SET} = 8.32\text{ k}\Omega$ $I_{VOUT} = 0\text{ mA}$		30		
		$3\text{ V} \leq V_{IN} \leq 5.5\text{ V}$ $R_{SET} = 24.9\text{ k}\Omega$ $I_{VOUT} = 0\text{ mA}$		10		
$I_{D-MATCH}$	LED current matching ⁽³⁾	$R_{SET} = 8.32\text{ k}\Omega$	0.2	1.5%		
I_Q	Quiescent supply current	$D_{(1-4)} = \text{OPEN}$ $R_{SET} = \text{OPEN}$	1.5	1.9	mA	
I_{SD}	Shutdown supply current	$3\text{ V} \leq V_{IN} \leq 5.5\text{ V}$ $V(\text{EN}) = 0\text{ V}$	0.1	1	μA	
V_{SET}	I_{SET} pin voltage	$3\text{ V} \leq V_{IN} \leq 5.5\text{ V}$	1.25		V	
I_{DX} / I_{SET}	Output current to current set ratio		200			
V_{HR}	Current source voltage headroom requirement ⁽⁴⁾	$I_{DX} = 95\% I_{DX}$ (nominal) $R_{SET} = 8.32\text{ k}\Omega$ (I_{DX} nominal = 30 mA)	360		mV	
		$I_{DX} = 95\% I_{DX}$ (nom.) $R_{SET} = 12.5\text{ k}\Omega$ (I_{DX} nom. = 20 mA)	240			
f_{SW}	Switching frequency	525 (-30%)	750	975 (30%)	kHz	
V_{IH}	Logic input high	Input pins: EN, PWM $3\text{ V} \leq V_{IN} \leq 5.5\text{ V}$	1	V_{IN}	V	
V_{IL}	Logic input low	Input pins: EN, PWM $3\text{ V} \leq V_{IN} \leq 5.5\text{ V}$	0	0.4		
I_{IH}	Logic input high current	Input pin: PWM $V(\text{PWM}) = 1.8\text{ V}$	10		nA	
		Input pin: EN $V(\text{EN}) = 1.8\text{ V}$ ⁽⁵⁾	12		μA	
I_{IL}	Logic input low current	Input pins: EN, PWM $V(\text{EN}, \text{PWM}) = 0\text{ V}$	10		nA	
R_{OUT}	Charge pump output resistance ⁽⁶⁾		3.3		Ω	
V_{GDx}	1x to 3/2x gain transition voltage threshold on V_{DX}	($V_{OUT} - V_{DX}$) Falling	500		mV	
t_{ON}	Start-up time	$I_{DX} = 90\%$ steady state	330		μs	

(1) All voltages are with respect to the potential at the GND pin.

(2) C_{IN} , C_{OUT} , C_1 , C_2 : Low-ESR surface-mount ceramic capacitors (MLCCs) used in setting electrical characteristics.

(3) LED current matching is based on two calculations: $[(I_{MAX} - I_{AVG}) / I_{AVG}]$ and $[(I_{AVG} - I_{MIN}) / I_{AVG}]$. I_{MAX} and I_{MIN} are the highest and lowest respective Dx currents, and I_{AVG} is the average Dx current of all four current sources. The largest number of the two calculations (worst case) is considered the matching figure for the part. The typical specification provided is the most likely norm of the matching figure for all parts.

(4) Headroom voltage (V_{HR}) = $V_{OUT} - V_{DX}$. If headroom voltage requirement is not met, LED current regulation may be compromised.

(5) EN logic input high current (I_{IH}) is due to a 150-k Ω (typical) pulldown resistor connected internally between the EN and GND pins.

(6) The open-loop output resistance (R_{OUT}) models all voltage losses in the charge pump. R_{OUT} can be used to estimate the voltage at the charge pump output V_{OUT} and the maximum current capability of the device under low V_{IN} and high I_{OUT} conditions, beyond what is specified in the electrical specifications table: $V_{OUT} = (G \times V_{IN}) - (R_{OUT} \times I_{OUT})$. In the equation, G is the charge-pump-gain mode, and I_{OUT} is the total output current (sum of all active Dx current sources and all current drawn from V_{OUT}).

6.6 Typical Characteristics

Unless otherwise specified: $T_A = 25^\circ\text{C}$, 4 LEDs, $V_{DX} = 3.6\text{ V}$, $V_{IN} = 3.6\text{ V}$, $V_{EN} = V_{IN}$, $V_{PWM} = V_{IN}$, $C_1 = C_2 = 1\mu\text{F}$, $C_{IN} = C_{OUT} = 3.3\mu\text{F}$. Capacitors are low-ESR multi-layer ceramic capacitors (MLCCs).

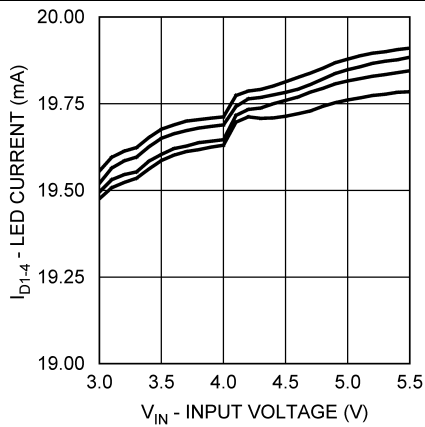

Figure 1. LED Current Regulation vs Input Voltage

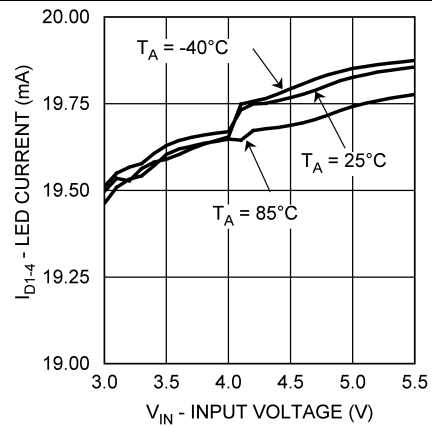
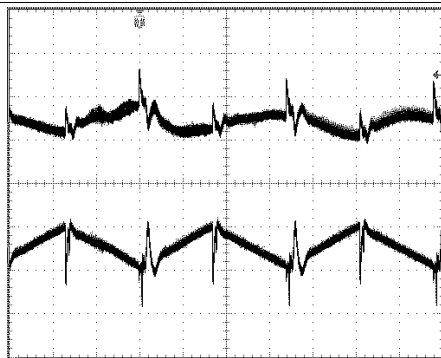
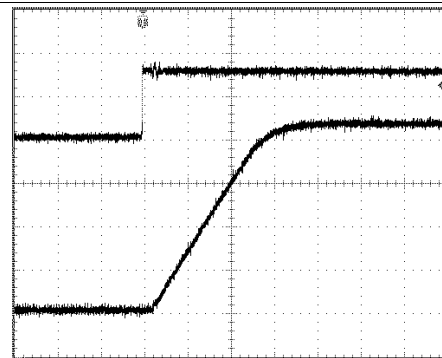

Figure 2. Average LED Current Regulation vs Input Voltage



$V_{IN} = 3.6\text{ V}$ Time scale: 400 ns/Div Load = 15 mA/LED, 4 LEDs
 CH1 (TOP): V_{IN} ; Scale: 20mV/Div, AC Coupled
 CH2 (BOTTOM): V_{OUT} ; Scale: 20mV/Div, AC Coupled

Figure 3. Input and Output Voltage Ripple



$V_{IN} = 3.6\text{ V}$ Time scale: 100 $\mu\text{s}/\text{Div}$ Load = 20mA/LED, 4 LEDs
 CH1 (TOP): V_{EN} ; Scale: 1 V/Div
 CH2 (BOTTOM): V_{OUT} ; Scale: 1 V/Div

Figure 4. Start-Up Response

7 Detailed Description

7.1 Overview

The LM27951 is an adaptive 1.5x/1x CMOS charge pump, optimized for driving white LEDs used in small-format display backlighting. It provides four constant current outputs capable of sourcing up to 30 mA through each LED. The well-matched current sources ensure the current through all the LEDs are virtually identical, providing a uniform brightness across the entire display.

Each current source is internally connected to the charge pump output, V_{OUT} . LED drive current is programmed by connecting a resistor, R_{SET} , to the current set pin, I_{SET} . LED brightness is adjusted by applying a pulse width modulated (PWM) signal to the dedicated PWM input pin.

7.2 Functional Block Diagram

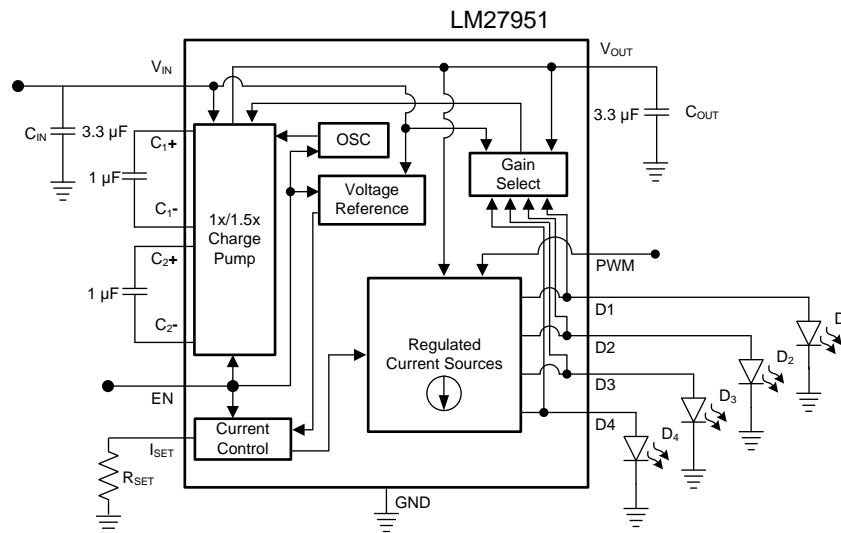

7.3 Feature Description

7.3.1 Charge Pump

The input to the 1.5x/1x charge pump is connected to the V_{IN} pin, and the loosely regulated output of the charge pump is connected to the V_{OUT} pin. The recommended input voltage range of the LM27951 is 3 V to 5.5 V. The loosely regulated charge pump of the device has both open loop and closed loop modes of operation. When the device is in open loop, the voltage at V_{OUT} is equal to the gain times the voltage at the input. When the device is in closed loop, the voltage at V_{OUT} is loosely regulated to 4.5 V (typical). The charge pump gain transitions are actively selected to maintain regulation based on LED forward voltage and load requirements. This allows the charge pump to stay in the most efficient gain (1x) over as much of the input voltage range as possible, reducing the power consumed from the battery.

7.3.2 Soft Start

The LM27951 contains internal soft-start circuitry to limit input inrush currents when the part is enabled. Soft start is implemented internally with a controlled turnon of the internal voltage reference. Due to the soft-start circuitry, startup time of the LM27951 is approximately 330 μ s (typical).

7.3.3 Thermal Protection

Internal thermal protection circuitry disables the LM27951 when the junction temperature exceeds 150°C (typical). This feature protects the device from being damaged by high die temperatures that might otherwise result from excessive power dissipation. The device recovers and operate normally when the junction temperature falls below 140°C (typical). It is important that the board layout provide good thermal conduction to keep the junction temperature within the specified operating ratings.

7.4 Device Functional Modes

7.4.1 Enable and PWM Pins

The LM27951 has 2 logic control pins. Both pins are active-high logic (HIGH = ON). There is an internal pulldown resistor (150 k Ω typical) connected between the enable pin (EN) and GND. There is no pullup or pulldown connected to the pulse width modulated (PWM) pin.

The EN pin is the master enable pin for the part. When the voltage on this pin is low (< 0.4 V), the part is in shutdown mode. In this mode, all internal circuitry is OFF and the part consumes very little supply current (< 1 μ A typical). When the voltage on the EN pin is high (> 1 V), the device activates the charge pump and regulate the output voltage to its nominal value.

The PWM pin serves as a dedicated logic input for LED brightness control. When the voltage on this pin is low (< 0.4 V), the current sources are turned off, and no current flows through the LEDs. When the voltage on this pin is high (> 1 V), the currents sources turn on and regulate to the current level set by the resistor connected to the I_{SET} pin.

7.4.2 Adjusting LED Brightness (PWM Control)

Perceived LED brightness can be adjusted using a PWM control signal on the LM27951 PWM logic input pin, turning the current sources ON and OFF at a rate faster than perceptible by the human eye. When this is done, the total brightness perceived is proportional to the duty cycle (D) of the PWM signal (D = the percentage of time that the LED is on in every PWM cycle). A simple example: if the LEDs are driven at 15 mA each with a PWM signal that has a 50% duty cycle, perceived LED brightness is about half as bright as compared to when the LEDs are driven continuously with 15 mA.

The minimum recommended PWM frequency is 100 Hz. Frequencies below this may be visible as flicker or blinking. The maximum recommended PWM frequency is 1 kHz. Frequencies above this may cause interference with internal current driver circuitry and/or noise in the audible range. Due to the regulation control loop, the maximum frequency and minimum duty cycle applied to the PWM pin must be chosen such that the minimum ON time is no less than 30 μ s in duration. If a PWM signal is applied to the EN pin instead, the maximum frequency and minimum duty cycle should be chosen to accommodate both the LM27951 start-up time (330 μ s typical) and the 30- μ s control loop delay.

The preferred method to adjust brightness is to keep the master EN voltage ON continuously and apply a PWM signal to the dedicated PWM input pin. The benefit of this type of connection can be best understood with a contrary example. When a PWM signal is connected to the master enable (EN) pin, the charge pump repeatedly turns on and off. Every time the charge pump turns on, there is an inrush of current as the capacitors, both internal and external, are recharged. This inrush current results in a current spike and a voltage dip at the input of the part. By applying the PWM signal to PWM logic input pin, the charge pump remains active, resulting in much lower input noise.

When the PWM signal must be connected to the EN pin, measures can be taken to reduce the magnitude of the charge-pump turnon transient response. More input capacitance, series resistors, and/or ferrite beads may provide benefits. If the current spikes and voltage dips can be tolerated, connecting the PWM signal to the EN pin does provide a benefit of lower supply current consumption. When the PWM signal to the EN pin is low, the LM27951 is shut down, and the input current is only a few micro-amps. This results in a lower time-averaged input current than the prior suggestion, where EN is kept on continuously.

8 Application and Implementation

NOTE

Information in the following applications sections is not part of the TI component specification, and TI does not warrant its accuracy or completeness. TI's customers are responsible for determining suitability of components for their purposes. Customers should validate and test their design implementation to confirm system functionality.

8.1 Application Information

8.1.1 Maximum Output Current, Maximum LED Voltage, Minimum Input Voltage

The LM27951 can drive 4 LEDs at 30 mA each from an input voltage as low as 3 V, so long as the LEDs have a forward voltage of 3.6 V or less (room temperature).

The previous statement is a simple example of the LED drive capabilities of the LM27951. The statement contains key application parameters required to validate an LED-drive design using the LM27951: LED current (I_{LED}), number of active LEDs (N), LED forward voltage (V_{LED}), and minimum input voltage (V_{IN-MIN}).

[Equation 1](#) can be used to estimate the total output current capability of the LM27951:

$$I_{LED_MAX} = ((1.5 \times V_{IN}) - V_{LED}) / ((N \times R_{OUT}) + k_{HR})$$

where

- R_{OUT} = output resistance (1)

As an example of [Equation 1](#): $I_{LED_MAX} = ((1.5 \times V_{IN}) - V_{LED}) / ((N \times 3.3 \Omega) + 12 \text{ mV/mA})$.

This parameter models the internal losses of the charge pump that result in voltage droop at the pump output V_{OUT} . Because the magnitude of the voltage droop is proportional to the total output current of the charge pump, the loss parameter is modeled as a resistance. The output resistance of the LM27951 is typically 3.3Ω ($V_{IN} = 3 \text{ V}$, $T_A = 25^\circ\text{C}$ – see [Equation 2](#)).

$$V_{VOUT} = 1.5 \times V_{IN} - N \times I_{LED} \times R_{OUT}$$

where

- k_{HR} = headroom constant
- R_{OUT} = output resistance (2)

This parameter models the minimum voltage required across the current sources for proper regulation. This minimum voltage is proportional to the programmed LED current, so the constant has units of mV/mA. The typical k_{HR} of the LM27951 is 12 mV/mA – see [Equation 3](#):

$$(V_{VOUT} - V_{LED}) > k_{HR} \times I_{LED} \quad (3)$$

Maximum LED current is highly dependent on minimum input voltage and LED forward voltage. Output current capability can be increased by raising the minimum input voltage of the application, or by selecting LEDs with a lower forward voltage. Excessive power dissipation may also limit output current capability of an application.

8.2 Typical Application

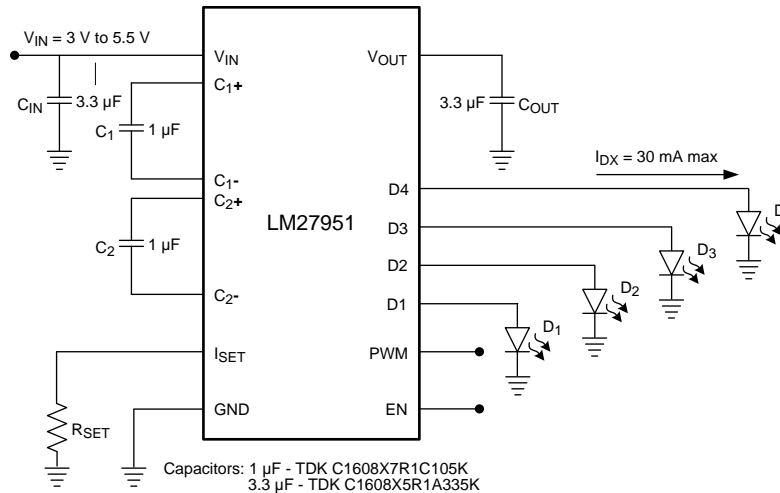

Figure 5. LM27951 Typical Application

8.2.1 Design Requirements

For typical white-LED switched capacitor applications, use the parameters listed in [Table 1](#).

Table 1. Design Parameters

DESIGN PARAMETER	EXAMPLE VALUE
Minimum input voltage	2.8 V
Output current	20 mA
R _{SET}	12.5 kΩ

8.2.2 Detailed Design Procedure

8.2.2.1 Setting LED Currents

The current through the four LEDs connected to D₁₋₄ can be set to a desired level simply by connecting an appropriately sized resistor (R_{SET}) between the I_{SET} pin of the LM27951 and GND. The LED currents are proportional to the current that flows out of the I_{SET} pin and are a factor of 200 times greater than the I_{SET} current. The feedback loop of an internal amplifier sets the voltage of the I_{SET} pin to 1.25 V (typical). The previous statements are simplified in [Equation 4](#) and [Equation 5](#):

$$I_{DX} = 200 \times (V_{SET} / R_{SET}) \quad (4)$$

$$R_{SET} = 200 \times (1.25 \text{ V} / I_{DX}) \quad (5)$$

8.2.2.2 Capacitor Selection

The LM27951 requires 4 external capacitors for proper operation. Surface-mount multi-layer ceramic capacitors are recommended. These capacitors are small, inexpensive and have very low equivalent series resistance (ESR) — < 20 mΩ typical. Tantalum capacitors, OS-CON capacitors, and aluminum electrolytic capacitors are not recommended for use with the LM27951 due to their high ESR, compared to ceramic capacitors.

For most applications, it is preferable to use ceramic capacitors with X7R or X5R temperature characteristic with the LM27951. These capacitors have tight capacitance tolerance (as good as ±10%) and hold their value over temperature (X7R: ±15% over –55°C to 125°C; X5R: ±15% over –55°C to +85°C).

Capacitors with Y5V or Z5U temperature characteristic are generally not recommended for use with the LM27951. Capacitors with these temperature characteristics typically have wide capacitance tolerance (80%, –20%) and vary significantly over temperature (Y5V: 22%, –82% over –30°C to +85°C range; Z5U: 22%, –56% over 10°C to 85°C range). Under some conditions, a nominal 1-μF Y5V or Z5U capacitor could have a capacitance of only 0.1 μF. Such detrimental deviation is likely to cause Y5V and Z5U capacitors to fail to meet the minimum capacitance requirements of the LM27951.

The voltage rating of the output capacitor must be 10 V or more. All other capacitors must have a voltage rating at or above the maximum input voltage of the application.

8.2.2.3 Parallel Dx Outputs for Increased Current Drive

Outputs D₁₋₄ may be connected together to drive a one or two LEDs at higher currents. In a one LED configuration, all four parallel current sources of equal value are connected together to drive a single LED. The LED current programmed must be chosen such that the current provided from each of the outputs is programmed to 25% of the total desired LED current. For example, if 60 mA is the desired drive current for the single LED, R_{SET} must be selected so that the current out of each current source is 15 mA. Similarly, if two LEDs are to be driven by pairing up the D₁₋₄ outputs (that is, D₁₋₂, D₃₋₄), R_{SET} must be selected so that the current out of each current source output is 50% of the desired LED current.

Connecting the outputs in parallel does not affect the internal operation of the LM27951 and has no impact on the electrical characteristics and limits previously presented. The available diode output current, maximum diode voltage, and all other specifications provided in the [Electrical Characteristics](#) apply to this parallel output configuration, just as they do to the standard 4-LED application circuit.

8.2.2.4 Power Efficiency

Efficiency of LED drivers is commonly taken to be the ratio of power consumed by the LEDs (P_{LED}) to the power drawn at the input of the part (P_{IN}). With a 1.5x/1x charge pump, the input current is equal to the charge pump gain times the output current (total LED current). For a simple approximation, the current consumed by internal circuitry can be neglected and the efficiency of the LM27951 can be predicted as follows:

$$P_{LED} = N \times V_{LED} \times I_{LED} \quad (6)$$

$$P_{IN} = V_{IN} \times I_{IN} \quad (7)$$

$$P_{IN} = V_{IN} \times (\text{Gain} \times N \times I_{LED} + I_Q) \quad (8)$$

$$E = (P_{LED} / P_{IN}) \quad (9)$$

Neglecting I_Q results in a slightly higher efficiency prediction, but this impact is no more than a few percentage points when several LEDs are driven at full power. It is also worth noting that efficiency as defined here is in part dependent on LED voltage. Variation in LED voltage does not affect power consumed by the circuit and typically does not relate to the brightness of the LED. For an advanced analysis, it is recommended that power consumed by the circuit (V_{IN} × I_{IN}) be evaluated rather than power efficiency.

8.2.2.5 Power Dissipation

The power dissipation (P_{DISSIPATION}) and junction temperature (T_J) can be approximated with [Equation 10](#) and [Equation 11](#). P_{IN} is the power generated by the 1.5x/1x charge pump, P_{LED} is the power consumed by the LEDs, T_A is the ambient temperature, and R_{θJA} is the junction-to-ambient thermal resistance for the 14-pin WSON package. V_{IN} is the input voltage to the LM27951, V_{LED} is the nominal LED forward voltage, and I_{LED} is the programmed LED current.

$$P_{DISSIPATION} = P_{IN} - P_{LED} = [\text{Gain} \times V_{IN} \times (4 \times I_{LED})] - (V_{LED} \times 4 \times I_{LED}) \quad (10)$$

$$T_J = T_A + (P_{DISSIPATION} \times R_{\theta JA}) \quad (11)$$

The junction temperature rating takes precedence over the ambient temperature rating. The LM27951 may be operated outside the ambient temperature rating, so long as the junction temperature of the device does not exceed the maximum operating rating of 115°C. The maximum ambient temperature rating must be derated in applications where high power dissipation and/or poor thermal resistance causes the junction temperature to exceed 115°C.

8.2.3 Application Curves

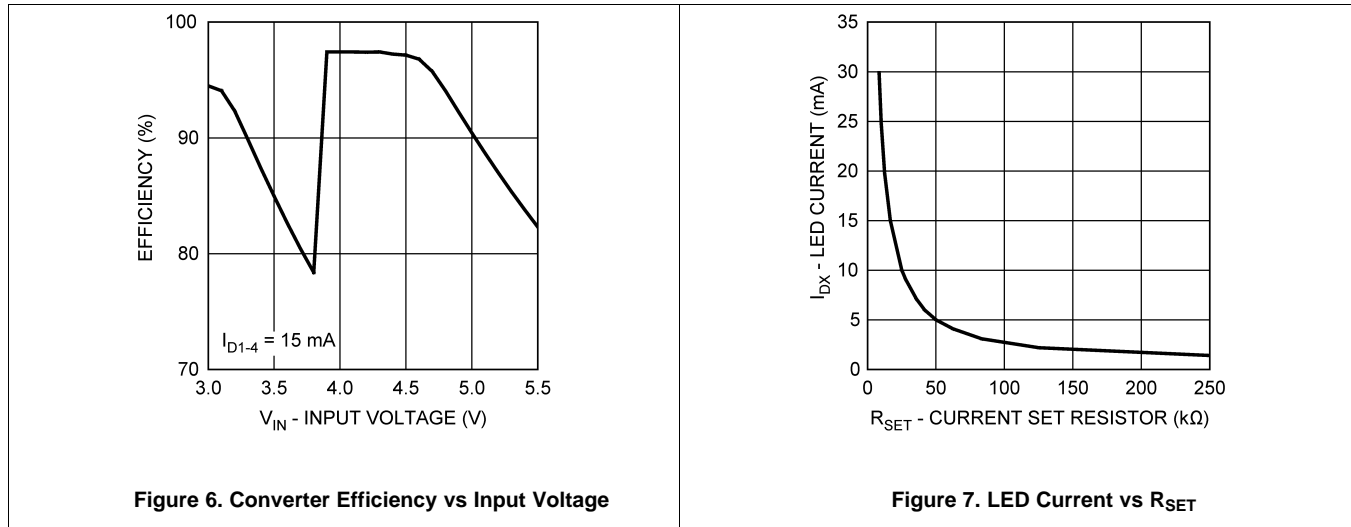

9 Power Supply Recommendations

The LM27951 is designed to operate from an input voltage supply range from 2.8 V to 5.5 V. This input supply must be well regulated and capable to supply the required input current. If the input supply is located far from the device, additional bulk capacitance may be required in addition to the ceramic bypass capacitors.

10 Layout

10.1 Layout Guidelines

The WSON is a leadframe-based chip scale package (CSP) with very good thermal properties. This package has an exposed DAP (die attach pad) thermal pad at the center of the package measuring 3 mm × 1.6 mm. The main advantage of this exposed DAP is to offer lower thermal resistance when it is soldered to the thermal land on the PCB. For PCB layout, TI highly recommends a 1:1 ratio between the package and the PCB thermal land. To further enhance thermal conductivity, the PCB thermal land may include vias to a ground plane. For more detailed instructions on mounting WSON packages, refer to *AN-1187 Leadless Leadframe Package (LLP) SNOA401*.

10.2 Layout Example

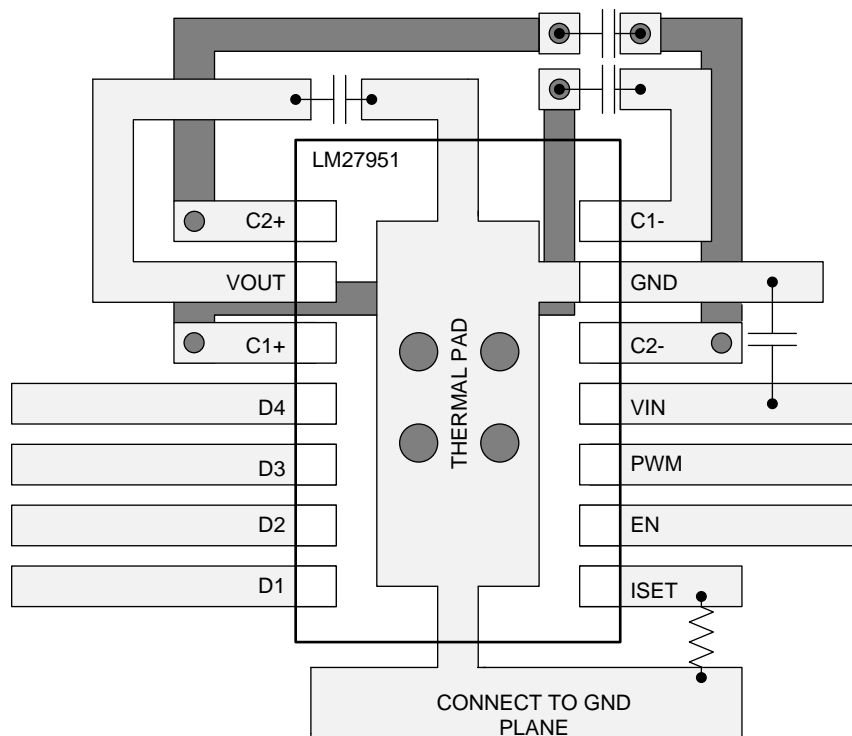

11 Device and Documentation Support

11.1 Device Support

11.1.1 Third-Party Products Disclaimer

TI'S PUBLICATION OF INFORMATION REGARDING THIRD-PARTY PRODUCTS OR SERVICES DOES NOT CONSTITUTE AN ENDORSEMENT REGARDING THE SUITABILITY OF SUCH PRODUCTS OR SERVICES OR A WARRANTY, REPRESENTATION OR ENDORSEMENT OF SUCH PRODUCTS OR SERVICES, EITHER ALONE OR IN COMBINATION WITH ANY TI PRODUCT OR SERVICE.

11.2 Documentation Support

11.2.1 Related Documentation

For additional information, see the following:

AN-1187 Leadless Leadframe Package (LLP) ([SNOA401](#))

11.3 Community Resources

The following links connect to TI community resources. Linked contents are provided "AS IS" by the respective contributors. They do not constitute TI specifications and do not necessarily reflect TI's views; see TI's [Terms of Use](#).

TI E2E™ Online Community *TI's Engineer-to-Engineer (E2E) Community*. Created to foster collaboration among engineers. At [e2e.ti.com](#), you can ask questions, share knowledge, explore ideas and help solve problems with fellow engineers.

Design Support *TI's Design Support* Quickly find helpful E2E forums along with design support tools and contact information for technical support.

11.4 Trademarks

E2E is a trademark of Texas Instruments.
All other trademarks are the property of their respective owners.

11.5 Electrostatic Discharge Caution



These devices have limited built-in ESD protection. The leads should be shorted together or the device placed in conductive foam during storage or handling to prevent electrostatic damage to the MOS gates.

11.6 Glossary

[SLYZ022](#) — *TI Glossary*.

This glossary lists and explains terms, acronyms, and definitions.

12 Mechanical, Packaging, and Orderable Information

The following pages include mechanical, packaging, and orderable information. This information is the most current data available for the designated devices. This data is subject to change without notice and revision of this document. For browser-based versions of this data sheet, refer to the left-hand navigation.

PACKAGING INFORMATION

Orderable Device	Status (1)	Package Type	Package Drawing	Pins	Package Qty	Eco Plan (2)	Lead/Ball Finish (6)	MSL Peak Temp (3)	Op Temp (°C)	Device Marking (4/5)	Samples
LM27951SD/NOPB	ACTIVE	WSO	NHK	14	1000	Green (RoHS & no Sb/Br)	CU SN	Level-1-260C-UNLIM	-40 to 85	D006B	Samples
LM27951SDX/NOPB	ACTIVE	WSO	NHK	14	4500	Green (RoHS & no Sb/Br)	CU SN	Level-1-260C-UNLIM	-40 to 85	D006B	Samples

(1) The marketing status values are defined as follows:

ACTIVE: Product device recommended for new designs.

LIFEBUY: TI has announced that the device will be discontinued, and a lifetime-buy period is in effect.

NRND: Not recommended for new designs. Device is in production to support existing customers, but TI does not recommend using this part in a new design.

PREVIEW: Device has been announced but is not in production. Samples may or may not be available.

OBSOLETE: TI has discontinued the production of the device.

(2) **RoHS:** TI defines "RoHS" to mean semiconductor products that are compliant with the current EU RoHS requirements for all 10 RoHS substances, including the requirement that RoHS substance do not exceed 0.1% by weight in homogeneous materials. Where designed to be soldered at high temperatures, "RoHS" products are suitable for use in specified lead-free processes. TI may reference these types of products as "Pb-Free".

RoHS Exempt: TI defines "RoHS Exempt" to mean products that contain lead but are compliant with EU RoHS pursuant to a specific EU RoHS exemption.

Green: TI defines "Green" to mean the content of Chlorine (Cl) and Bromine (Br) based flame retardants meet JS709B low halogen requirements of <=1000ppm threshold. Antimony trioxide based flame retardants must also meet the <=1000ppm threshold requirement.

(3) MSL, Peak Temp. - The Moisture Sensitivity Level rating according to the JEDEC industry standard classifications, and peak solder temperature.

(4) There may be additional marking, which relates to the logo, the lot trace code information, or the environmental category on the device.

(5) Multiple Device Markings will be inside parentheses. Only one Device Marking contained in parentheses and separated by a "~" will appear on a device. If a line is indented then it is a continuation of the previous line and the two combined represent the entire Device Marking for that device.

(6) Lead/Ball Finish - Orderable Devices may have multiple material finish options. Finish options are separated by a vertical ruled line. Lead/Ball Finish values may wrap to two lines if the finish value exceeds the maximum column width.

Important Information and Disclaimer:The information provided on this page represents TI's knowledge and belief as of the date that it is provided. TI bases its knowledge and belief on information provided by third parties, and makes no representation or warranty as to the accuracy of such information. Efforts are underway to better integrate information from third parties. TI has taken and continues to take reasonable steps to provide representative and accurate information but may not have conducted destructive testing or chemical analysis on incoming materials and chemicals. TI and TI suppliers consider certain information to be proprietary, and thus CAS numbers and other limited information may not be available for release.

In no event shall TI's liability arising out of such information exceed the total purchase price of the TI part(s) at issue in this document sold by TI to Customer on an annual basis.

TAPE AND REEL INFORMATION

QUADRANT ASSIGNMENTS FOR PIN 1 ORIENTATION IN TAPE

*All dimensions are nominal

Device	Package Type	Package Drawing	Pins	SPQ	Reel Diameter (mm)	Reel Width W1 (mm)	A0 (mm)	B0 (mm)	K0 (mm)	P1 (mm)	W (mm)	Pin1 Quadrant
LM27951SD/NOPB	WSON	NHK	14	1000	178.0	12.4	3.3	4.3	1.0	8.0	12.0	Q1
LM27951SDX/NOPB	WSON	NHK	14	4500	330.0	12.4	3.3	4.3	1.0	8.0	12.0	Q1

TAPE AND REEL BOX DIMENSIONS

*All dimensions are nominal

Device	Package Type	Package Drawing	Pins	SPQ	Length (mm)	Width (mm)	Height (mm)
LM27951SD/NOPB	WSON	NHK	14	1000	210.0	185.0	35.0
LM27951SDX/NOPB	WSON	NHK	14	4500	367.0	367.0	35.0

IMPORTANT NOTICE AND DISCLAIMER

TI PROVIDES TECHNICAL AND RELIABILITY DATA (INCLUDING DATASHEETS), DESIGN RESOURCES (INCLUDING REFERENCE DESIGNS), APPLICATION OR OTHER DESIGN ADVICE, WEB TOOLS, SAFETY INFORMATION, AND OTHER RESOURCES "AS IS" AND WITH ALL FAULTS, AND DISCLAIMS ALL WARRANTIES, EXPRESS AND IMPLIED, INCLUDING WITHOUT LIMITATION ANY IMPLIED WARRANTIES OF MERCHANTABILITY, FITNESS FOR A PARTICULAR PURPOSE OR NON-INFRINGEMENT OF THIRD PARTY INTELLECTUAL PROPERTY RIGHTS.

These resources are intended for skilled developers designing with TI products. You are solely responsible for (1) selecting the appropriate TI products for your application, (2) designing, validating and testing your application, and (3) ensuring your application meets applicable standards, and any other safety, security, or other requirements. These resources are subject to change without notice. TI grants you permission to use these resources only for development of an application that uses the TI products described in the resource. Other reproduction and display of these resources is prohibited. No license is granted to any other TI intellectual property right or to any third party intellectual property right. TI disclaims responsibility for, and you will fully indemnify TI and its representatives against, any claims, damages, costs, losses, and liabilities arising out of your use of these resources.

TI's products are provided subject to TI's Terms of Sale (www.ti.com/legal/termsofsale.html) or other applicable terms available either on ti.com or provided in conjunction with such TI products. TI's provision of these resources does not expand or otherwise alter TI's applicable warranties or warranty disclaimers for TI products.

Mailing Address: Texas Instruments, Post Office Box 655303, Dallas, Texas 75265
Copyright © 2019, Texas Instruments Incorporated

Looking for pricing, stock, or lifecycle information?

Click below to explore more details on WIN SOURCE:

 [View LM27951SDX/NOPB on WIN SOURCE](#)

 [Texas Instruments](#) Information

Optimize Your Supply Chain with WIN SOURCE Solutions

-  Global Sourcing Solution
-  Obsolete Management
-  Cost Control Management
-  Shortage Management
-  Alternative Solution
-  Excess Inventory Management