



**THE DATASHEET OF
LM2792LDX-L**



LM2792 Current Regulated Switched Capacitor LED Driver with Analog Brightness Control

Check for Samples: [LM2792](#)

FEATURES

- Output Matching of $\pm 0.3\%$ (typ.)
- Drives up to Two LED's
- 3.0V to 5.8V Input Voltage
- Up to 34mA Output Current
- Soft Start Limits Inrush Current
- Analog Brightness Control
- Separate Shutdown Input
- Very Small Solution Size and No Inductor
- 1.4mA Typical Operating Current
- 1 μ A (max.) Shutdown Current
- 900kHz Switching Frequency (min.)
- Linear Regulation Generates Predictable Noise Spectrum
- WSON-10 Package: 3mm X 3mm X 0.8mm

APPLICATIONS

- White LED Display Backlights
- White LED Keypad Backlights
- 1-Cell Li-Ion Battery-operated Equipment Including PDAs, Hand-held PCs, Cellular Phones
- Flat Panel Displays

DESCRIPTION

The LM2792 is a CMOS charge-pump voltage doubler and regulator that provides two regulated current sources. They are designed to drive two white (or blue) LEDs with matched currents (within $\pm 0.3\%$) to produce balanced light sources for display backlights. The LM2792 accepts an input voltage range from 3.0V to 5.8V and maintain a constant current determined by an external set resistor.

The LM2792 delivers up to 34mA of load current to accommodate two high forward voltage (typically white) LEDs. The switching frequency is 900kHz (min.) to keep the conducted noise spectrum away from sensitive frequencies within portable RF devices.

The LM2792 offers full off to maximum current control through the BRGT pin. The output current linearly tracks the BRGT pin voltage. The LM2792 is available in active high or low shutdown versions. The shutdown pin reduces the operating current to 1 μ A (max.). The LM2792 is available in a 10 pin WSON CSP package.

Basic Application Circuit

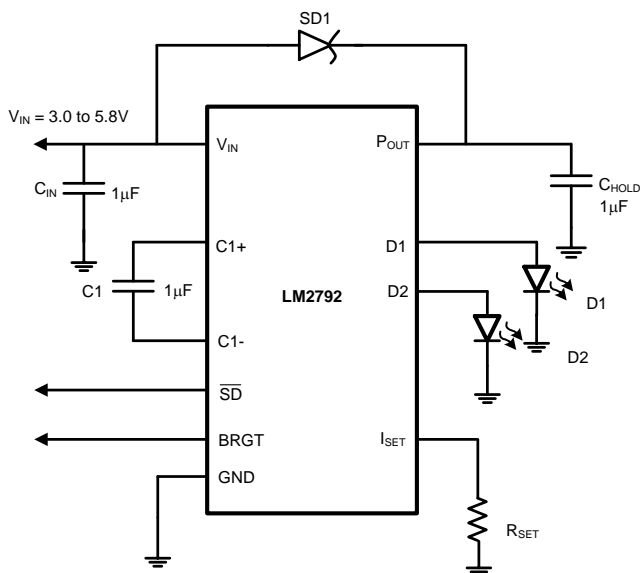

Please be aware that an important notice concerning availability, standard warranty, and use in critical applications of Texas Instruments semiconductor products and disclaimers thereto appears at the end of this data sheet.

All trademarks are the property of their respective owners.

Connection Diagram

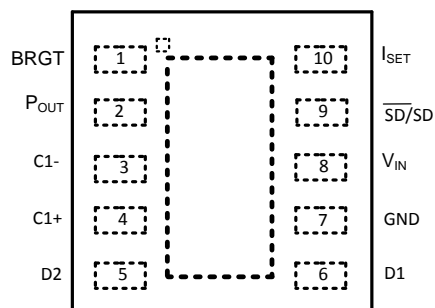
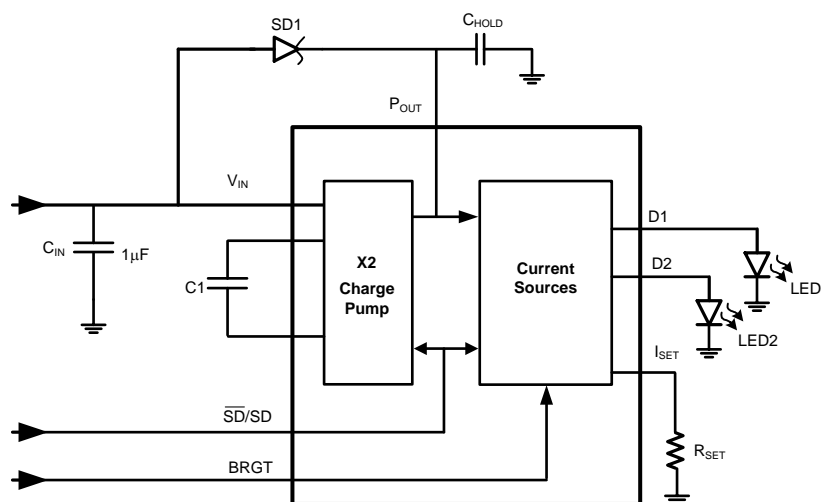

**Figure 1. Top View
10-Lead WSON**

PIN DESCRIPTIONS

Pin	Name	Function
1	BRGT	Variable voltage input controls output current.
2	P _{OUT}	Charge pump output.
3	C1-	Connect this pin to the negative terminal of C1.
4	C1+	Connect this pin to the positive terminal of C1.
5	D2	Current source outputs. Connect directly to LED.
6	D1	Current source outputs. Connect directly to LED.
7	GND	Power supply ground input.
8	V _{IN}	Power supply voltage input.
9	SD/ $\overline{\text{SD}}$	Shutdown input. Device operation is inhibited when pin is asserted.
10	I _{SET}	Current Sense Input. Connect resistor to ground to set constant current through LED.

Block Diagram





These devices have limited built-in ESD protection. The leads should be shorted together or the device placed in conductive foam during storage or handling to prevent electrostatic damage to the MOS gates.

ABSOLUTE MAXIMUM RATINGS⁽¹⁾⁽²⁾

V_{IN}	-0.3 to 6.0V
BRGT, SD	-0.3 to ($V_{IN} + 0.2V$)
Power Dissipation ⁽³⁾	400 mW
T_{JMAX} ⁽³⁾	150°C
θ_{JA} ⁽⁴⁾	55°C/W
Storage Temperature	-65°C to +150°C
Lead Temp. (Soldering, 5 sec.)	260°C
ESD Rating	
Human Body Model	2KV
Machine Model	200V

- (1) Absolute maximum ratings indicate limits beyond which damage to the device may occur. Electrical specifications do not apply when operating the device beyond its rated operating conditions.
- (2) If Military/Aerospace specified devices are required, please contact the Texas Instruments Sales Office/Distributors for availability and specifications.
- (3) D1 and D2 may be shorted to GND without damage. P_{OUT} may be shorted to GND for 1sec without damage.
- (4) For more information regarding the WSON package, please refer to Application note AN-1187 (literature number [SNOA401](#)).

OPERATING CONDITIONS

Input Voltage (V_{IN})	3.0V to 5.8V
BRGT	0 to 3.0V
Ambient Temperature (T_A)	-30°C to +85°C
34mA Operating Junction Temperature	-30°C to 100°C

ELECTRICAL CHARACTERISTICS

Limits in standard typeface are for $T_J = 25^\circ\text{C}$ and limits in **boldface type** apply over the full **Operating Temperature Range**. Unless otherwise specified, $C_1 = C_{IN} = C_{HOLD} = 1\ \mu\text{F}$, $V_{IN} = 3.6\text{V}$, BRGT pin = 2.75V.⁽¹⁾⁽²⁾

Symbol	Parameter	Conditions	Min	Typ	Max	Units
I_{DX}	Available Current at Output Dx	$3.0\text{V} \leq V_{IN} \leq 5.8\text{V}$ $V_{Dx} \leq 3.6\text{V}$ $R_{SET} = 1650\Omega$ $V_{BRGT} = 3\text{V}$	14.5	16.8		mA
I_{DX}	Line Regulation of Dx Output Current	$3.0\text{V} \leq V_{IN} \leq 4.4\text{V}$ $V_{Dx} \leq 3.6\text{V}$ $R_{SET} = 1800\Omega$ $V_{BRGT} = 2.75\text{V}$	13.5	16	17.8	mA
V_{Dx}	Load Regulation of Dx Output Current	$V_{IN} = 3.6\text{V}$ $V_{Dx} = 3.0\text{V}$ $V_{Dx} = 4.0\text{V}$ $R_{SET} = 1800\Omega$ $V_{BRGT} = 2.75\text{V}$		16.1 15.4		mA
$I_{D-MATCH}$	Current Matching Between Any Two Outputs	$V_{D1} = V_{D2} = 3.6\text{V}$, BRGT = 2.75V, $V_{IN} = 3.6\text{V}$, $R_{SET} = 1800\Omega$		0.3		%
I_Q	Quiescent Supply Current	$3.0\text{V} \leq V_{IN} \leq 4.4\text{V}$, Active, No Load Current		1.4	2.7	mA
I_{SD}	Shutdown Supply Current	$3.0\text{V} \leq V_{IN} \leq 5.5\text{V}$, Shutdown At 85°C		0.1 0.3	1	μA
V_{IH}	SD Input Logic High	$3.0\text{V} \leq V_{IN} \leq 5.5\text{V}$, Note5	$0.8 * V_{IN}$			V
V_{IL}	SD Input Logic Low	$3.0\text{V} \leq V_{IN} \leq 5.5\text{V}$, Note5			$0.2 * V_{IN}$	V
$I_{LEAK-SD}$	SD Input Leakage Current	$0\text{V} \leq V_{SD} \leq V_{IN}$		0.01		μA
R_{BRGT}	BRGT Input Resistance			250		k Ω
BRGT	Brightness Voltage Range		0		3.0	V
I_{SET}	I_{SET} Pin Output Current			$I_{Dx}/25$		mA
f_{SW}	Switching Frequency ⁽³⁾	$3.0\text{V} \leq V_{IN} \leq 4.4\text{V}$ $I_{D1} = I_{D2} \leq 16\text{mA}$	900	1100	1800	kHz
t_{START}	Startup Time ⁽⁴⁾	$I_{Dx} = 90\%$ steady state		10		μs

- (1) In the test circuit, all capacitors are 1.0 μF , 0.3 Ω maximum ESR capacitors. Capacitors with higher ESR will increase output resistance, reduce output voltage and efficiency.
- (2) The internal thresholds of the Shutdown bar are set at about 40% of V_{IN}
- (3) The output switches operate at one half of the oscillator frequency, $f_{OSC} = 2f_{SW}$.
- (4) This electrical specification is specified by design.

TYPICAL PERFORMANCE CHARACTERISTICS

Unless otherwise specified, $C_1 = C_{IN} = C_{HOLD} = 1\mu F$, $V_{IN} = 3.6V$, BRGT pin = 2.75V

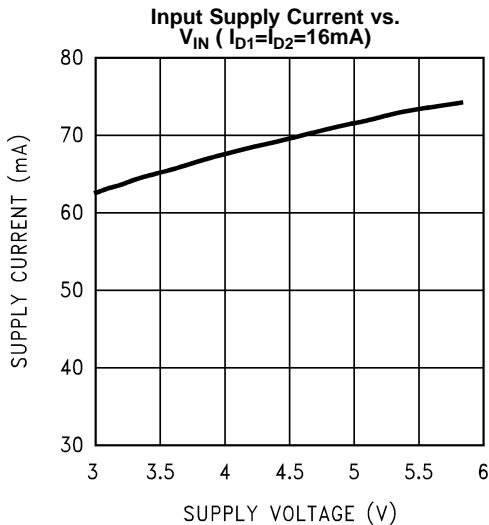

Figure 2.

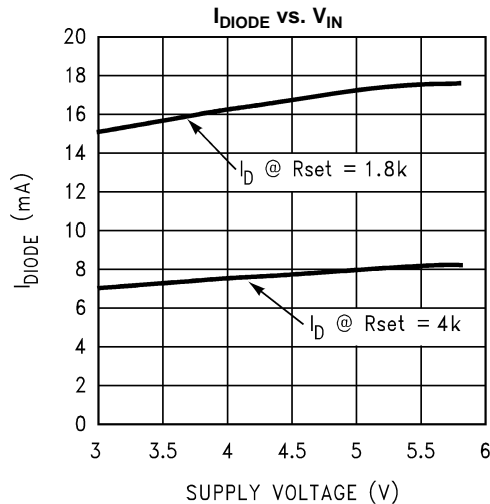

Figure 3.

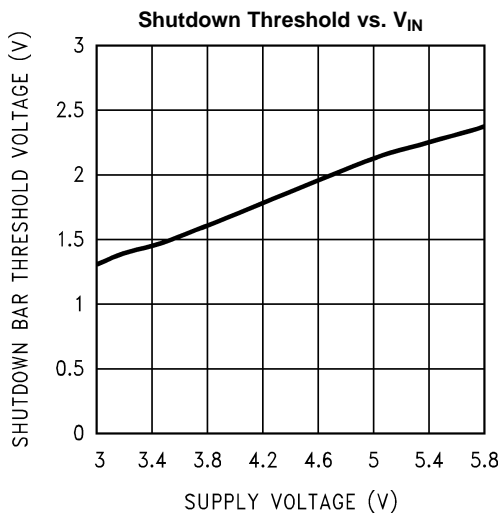

Figure 4.

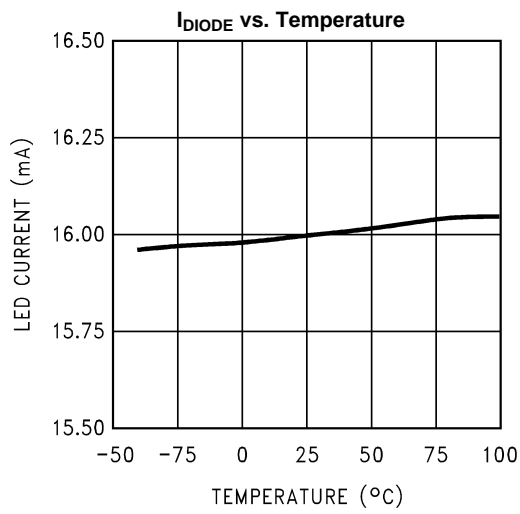

Figure 5.

TYPICAL PERFORMANCE CHARACTERISTICS (continued)

Unless otherwise specified, $C_1 = C_{IN} = C_{HOLD} = 1\mu\text{F}$, $V_{IN} = 3.6\text{V}$, BRGT pin = 2.75V

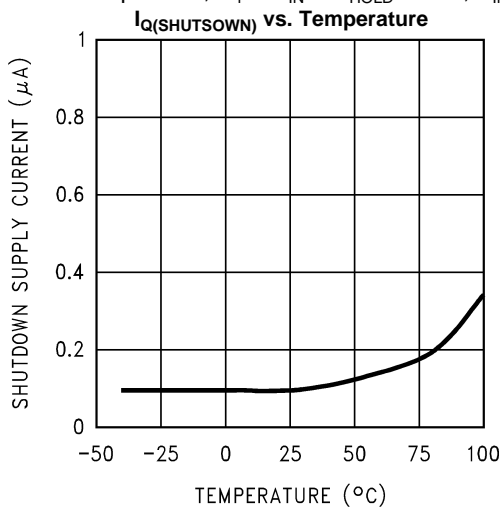

Figure 6.

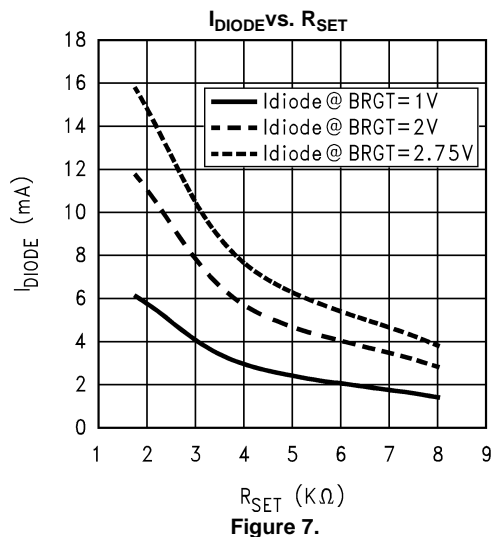

Figure 7.

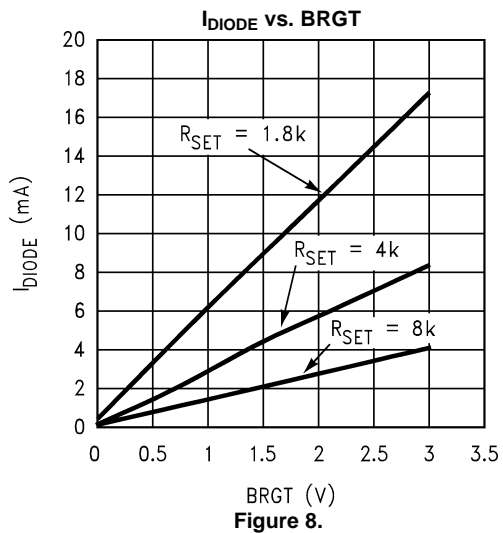

Figure 8.

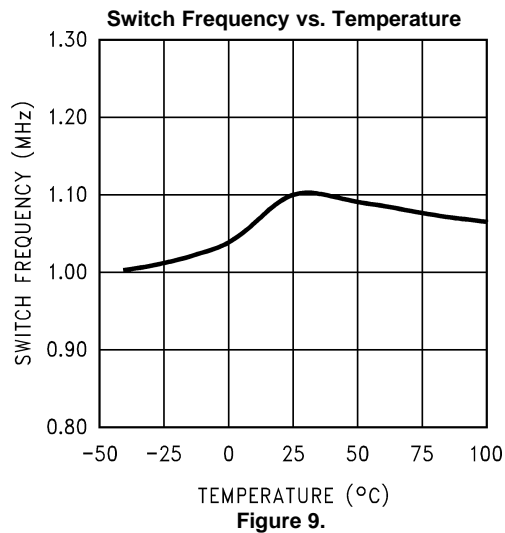

Figure 9.

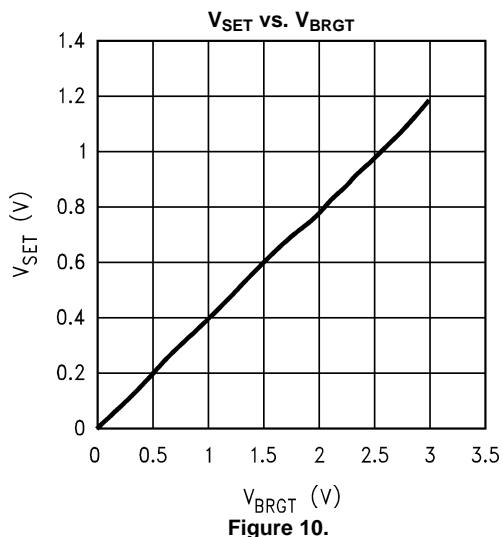

Figure 10.

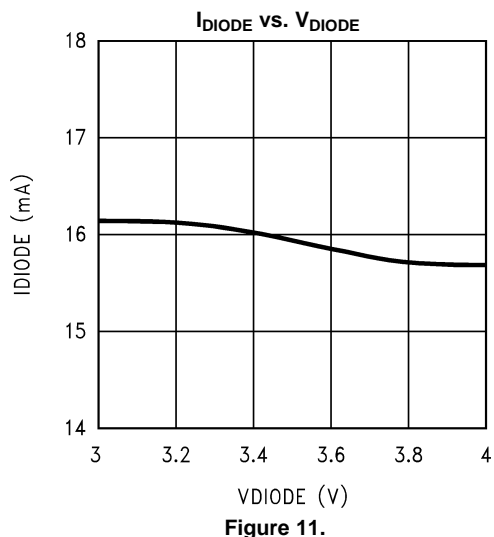

Figure 11.

CIRCUIT DESCRIPTION

The LM2792 provides two matched current sources for driving high forward voltage drop LEDs from Li-Ion battery sources. The part has on-chip current regulators which are composed of current mirrors with a 25 to 1 ratio. The mirrors control the LED current without using current limiting resistors in the LED current path. The device can drive up to 34mA through the LEDs.

The LED brightness can be controlled by both analog and/or digital methods. The digital technique uses a PWM (Pulse Width Modulation) signal applied to the shutdown input. The analog technique applies an analog voltage to the brightness (BRGT) pin (see [Application Information](#) section).

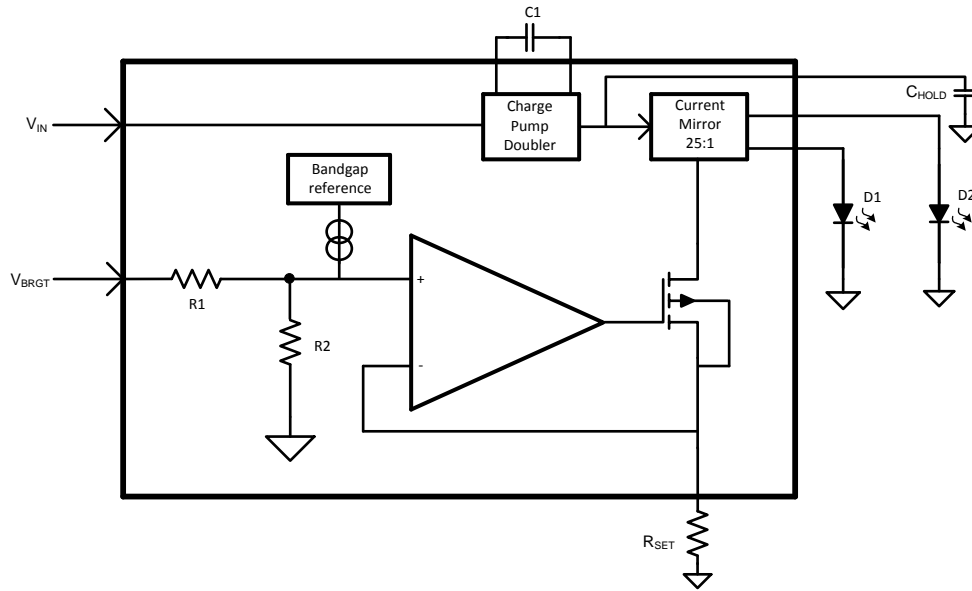

Figure 12.

APPLICATION INFORMATION

SOFT START

LM2792 includes a soft start function to reduce the inrush currents and high peak current during power up of the device. Soft start is implemented internally by ramping the bandgap more slowly than the applied voltage. This is done by holding the bandgap in shutdown for a short time. During soft start, the switch resistances limit the inrush current used to charge the flying and hold capacitors.

SHUTDOWN MODE

A shutdown pin (SD or $\overline{\text{SD}}$) is available to disable the LM2792 and reduce the quiescent current to 1 μ A maximum. The LM2792 is available with both senses of shutdown polarity.

During normal operation mode of the "-L" options, an active high logic signal to the $\overline{\text{SD}}$ pin or tying the $\overline{\text{SD}}$ pin to V_{IN} , will enable the device. Pulling $\overline{\text{SD}}$ low or connecting $\overline{\text{SD}}$ to ground will disable the device.

During normal operation mode of the "-H" options, an active low logic signal to the SD pin or tying the SD pin to GND, will enable the device. Pulling SD high or connecting SD to V_{IN} will disable the device.

CAPACITOR SELECTION

Low equivalent series resistance (ESR) capacitors such as X5R or X7R are recommended to be used for C_{IN} , C_1 , and C_{HOLD} for best performance. Ceramic capacitors with less than or equal to 0.3 ohms ESR value are recommended for this application. Table 1 below lists suggested capacitor suppliers for the typical application circuit.

Table 1. Low ESR Capacitor Manufactures

Manufacturer	Contact	website
TDK	(847) 803 6100	www.component.tdk.com
MuRata	(800) 831 9172	www.murata.com
Taiyo Yuden	(800) 348 2496	www.t-yuden.com

SCHOTTKY DIODE SELECTION

A schottky diode (SD1) must be used between V_{IN} and P_{OUT} for proper operation. During start-up, the low voltage drop across this diode is used to charge C_{OUT} and start the oscillator. It is necessary to protect the device from turning-on its own parasitic diode and potentially latching-up. As a result, it is important to select a schottky diode that will carry at least 200mA or higher current to charge the output capacitor during start-up. A schottky diode like 1N5817 can be used for most applications or a surface mount diode such as BAT54-series and MA2J704 can be used to reduce the circuit size. Table 2 below lists suggested schottky diode manufactures.

Table 2. Diode Manufactures

Manufacturer	Contact	website
ON Semiconductor	(800) 344 3860	www.onsemi.com
Phillips Semiconductors	(800) 234 7381	www.nxp.com
Panasonic Semiconductors	(408) 945 5622	www.panasonic.com

LED SELECTION

The LM2792 is designed to drive LEDs with a forward voltage of about 3.0V to 4.0V or higher. The typical and maximum V_F depends highly on the manufacturer and their technology. Table 3 lists two suggested manufactures and example part numbers. Each supplier makes many LEDs that work well with the LM2792. The LEDs suggested below are in a surface mount package and TOPLED or SIDEVIEW configuration with a maximum forward current of 20mA. These diodes also come in SIDELED or SIDEVIEW configuration and various chromaticity groups. For applications that demand color and brightness matching, care must be taken to select LEDs from the same chromaticity group. Forward current matching is assured over the LED process variations due to the constant current output of the LM2792. For best fit selection for an application, consult the manufacturer for detailed information.

Table 3. White LED Selection

Component	Manufacturer	Contact
LWT673/LWT67C	Osram	www.osram-os.com
NSCW100/NSCW215	Nichia	www.nichia.com

I_{SET}PIN

An external resistor, R_{SET}, sets the mirror current that is required to provide a constant current through the LEDs. The current through R_{SET} and the LED is set by the internal current mirror circuitry with a ratio of 25:1. The currents through each LED are matched within 0.3%. R_{SET} should be chosen not to exceed the maximum current delivery capability of the device. Table 4 shows a list of R_{SET} values when maximum BRGT=3V is applied. For other BRGT voltages, R_{SET} can be calculated using this formula:

$$R_{SET} = ((0.42 \cdot BRGT) / I_{SET}) \cdot 25$$

Table 4. R_{SET} Selections (when BRGT pin = 3V maximum)

I _{LED} per LED	R _{SET}
15mA	2.1KΩ
10mA	3.15KΩ
5mA	6.3KΩ

BRGT PIN

The BRGT pin can be used to smoothly vary the brightness of the LEDs. In the LM2792, current on BRGT is connected to an internal resistor divider which gives a factor of 0.42 (see Figure 12). This voltage is fed to the operational amplifier that controls the current through the mirror resistor R_{SET}. The nominal range on BRGT is 0V to 3V.

This means some current must be provided on the BRGT pin or no current will flow through the LEDs. The LM2792 can provide an infinite ratio, from fully off (essentially zero current) to the maximum current set by the R_{SET} resistor. Care must be taken to prevent voltages on BRGT that cause LED current to exceed a total of 34mA. Although this will not cause damage to the IC, it will not meet the ensured specifications listed in the [Electrical Characteristics](#).

Calculation of LED Current When Using BRGT :

$$V_{IN} = 3.6V$$

$$R_{SET} = 1800\Omega$$

$$I_{SET} = ((V_{BRGT} \cdot 0.42) / R_{SET}) \cdot 25$$

$$I_{SET} = ((2.75 \cdot 0.42) / 1800) \cdot 25 = 16mA$$

Note that making V_{BRGT} = 0V results in I_{SET} ~ = 0mA

BRIGHTNESS CONTROL USING PWM

Brightness control can be implemented by pulsing a signal at the SD pin. The recommended signal should be between 100Hz to 1kHz. If the operating PWM frequency is much less than 100Hz, flicker may be seen in the LEDs. Likewise, if frequency is much higher, brightness in the LEDs will not be linear. When a PWM signal is used to drive the SD pin of the LM2792, connect BRGT pin to a maximum of 3V to ensure the widest range. Similarly, the voltage at the BRGT pin can be set higher than 3V without damage to the IC, it will not increase the brightness of the LED significantly. R_{SET} value is selected using the above I_{SET} equation as if BRGT pin is used. The brightness is controlled by increasing and decreasing the duty cycle of the PWM. Zero duty cycle will turn off the brightness and a 50% duty cycle waveform produces an average current of 7.5mA if R_{SET} is set to produce a maximum LED current of 15mA. So the LED current varies linearly with the duty cycle.

PARALLEL DX OUTPUTS FOR INCREASED CURRENT DRIVE

Outputs D1 and D2 may be connected together to drive a single LED. In such a configuration, two parallel current sources of equal value drive the single LED. R_{SET} and V_{BRGT} should be chosen so that the current through each of the outputs is programmed to 50% of the total desired LED current. For example, if 30mA is the desired drive current for the single LED, R_{SET} and V_{BRGT} should be selected so that the current through each of the outputs is 15mA. Connecting the outputs in parallel does not affect internal operation of the LM2792 and has no impact on the Electrical Characteristics and limits previously presented. The available Dx output current, maximum Dx voltage, and all other specifications provided in the Electrical Characteristics table apply to this parallel output configuration, just as they do to the standard 2-LED application circuit.

THERMAL PROTECTION

The LM2792 has internal thermal protection circuitry to disable the charge pump if the junction temperature exceeds 150°C. This feature will protect the device from damage due to excessive power dissipation. The device will recover and operate normally when the junction temperature falls below the maximum operating junction temperature of 100°C. It is important to have good thermal conduction with a proper layout to reduce thermal resistance.

POWER EFFICIENCY

An ideal power efficiency for a voltage doubler switched capacitor converter is given as the output voltage of the doubler over twice the input voltage as follows:

$$\text{Efficiency} = (V_{DIODE} * I_{DIODE}) / (V_{IN} * I_{DIODE} * \text{Gain}) = V_{DIODE} / 2V_{IN}$$

In the case of the LM2792, a more accurate efficiency calculation can be applied as the given formula below.

$$\text{Efficiency} = ((V_{D1} * I_{D1}) + (V_{D2} * I_{D2})) / (I_{SUPPLY} * V_{IN})$$

It is clear that the efficiency will depend on the supply voltage in the above equation. As such, the lower the supply voltage, the higher the efficiency.

POWER DISSIPATION

The maximum allowable power dissipation that this package is capable of handling can be determined as follows:

$$P_{DMax} = (T_{JMax} - T_A) / \theta_{JA}$$

where

- T_{JMax} is the maximum junction temperature
- T_A is the ambient temperature
- θ_{JA} is the junction-to-ambient thermal resistance of the specified package

The actual power dissipation of the device can be calculated using this equation:

$$P_{Dissipation} = (2V_{IN} - V_{DIODE}) * I_{LOAD}$$

As an example, if V_{IN} in the target application is 4.2V, $V_{DIODE} = 3.0V$ and worst case current consumption is 32mA (17mA for each diode).

$$P_{Dissipation} = ((2 * 4.2) - 3.0) * 0.032 = 173mW$$

Power dissipation must be less than that allowed by the package. Please refer to the [Absolute Maximum Rating](#) of the LM2792.

PCB LAYOUT CONSIDERATIONS

The WSON is a leadframe based Chip Scale Package (CSP) with very good thermal properties. This package has an exposed DAP (die attach pad) at the center of the package measuring 2.0mm x 1.2mm. The main advantage of this exposed DAP is to offer lower thermal resistance when it is soldered to the thermal land on the PCB. For PCB layout, TI highly recommends a 1:1 ratio between the package and the PCB thermal land. To further enhance thermal conductivity, the PCB thermal land may include vias to a ground plane. For more detailed instructions on mounting WSON packages, please refer to Application Note AN-1187 (literature number [SNOA401](#)).

REVISION HISTORY

Changes from Revision K (April 2013) to Revision L	Page
• Changed layout of National Data Sheet to TI format	10

IMPORTANT NOTICE

Texas Instruments Incorporated and its subsidiaries (TI) reserve the right to make corrections, enhancements, improvements and other changes to its semiconductor products and services per JESD46, latest issue, and to discontinue any product or service per JESD48, latest issue. Buyers should obtain the latest relevant information before placing orders and should verify that such information is current and complete. All semiconductor products (also referred to herein as "components") are sold subject to TI's terms and conditions of sale supplied at the time of order acknowledgment.

TI warrants performance of its components to the specifications applicable at the time of sale, in accordance with the warranty in TI's terms and conditions of sale of semiconductor products. Testing and other quality control techniques are used to the extent TI deems necessary to support this warranty. Except where mandated by applicable law, testing of all parameters of each component is not necessarily performed.

TI assumes no liability for applications assistance or the design of Buyers' products. Buyers are responsible for their products and applications using TI components. To minimize the risks associated with Buyers' products and applications, Buyers should provide adequate design and operating safeguards.

TI does not warrant or represent that any license, either express or implied, is granted under any patent right, copyright, mask work right, or other intellectual property right relating to any combination, machine, or process in which TI components or services are used. Information published by TI regarding third-party products or services does not constitute a license to use such products or services or a warranty or endorsement thereof. Use of such information may require a license from a third party under the patents or other intellectual property of the third party, or a license from TI under the patents or other intellectual property of TI.

Reproduction of significant portions of TI information in TI data books or data sheets is permissible only if reproduction is without alteration and is accompanied by all associated warranties, conditions, limitations, and notices. TI is not responsible or liable for such altered documentation. Information of third parties may be subject to additional restrictions.

Resale of TI components or services with statements different from or beyond the parameters stated by TI for that component or service voids all express and any implied warranties for the associated TI component or service and is an unfair and deceptive business practice. TI is not responsible or liable for any such statements.

Buyer acknowledges and agrees that it is solely responsible for compliance with all legal, regulatory and safety-related requirements concerning its products, and any use of TI components in its applications, notwithstanding any applications-related information or support that may be provided by TI. Buyer represents and agrees that it has all the necessary expertise to create and implement safeguards which anticipate dangerous consequences of failures, monitor failures and their consequences, lessen the likelihood of failures that might cause harm and take appropriate remedial actions. Buyer will fully indemnify TI and its representatives against any damages arising out of the use of any TI components in safety-critical applications.

In some cases, TI components may be promoted specifically to facilitate safety-related applications. With such components, TI's goal is to help enable customers to design and create their own end-product solutions that meet applicable functional safety standards and requirements. Nonetheless, such components are subject to these terms.

No TI components are authorized for use in FDA Class III (or similar life-critical medical equipment) unless authorized officers of the parties have executed a special agreement specifically governing such use.

Only those TI components which TI has specifically designated as military grade or "enhanced plastic" are designed and intended for use in military/aerospace applications or environments. Buyer acknowledges and agrees that any military or aerospace use of TI components which have **not** been so designated is solely at the Buyer's risk, and that Buyer is solely responsible for compliance with all legal and regulatory requirements in connection with such use.

TI has specifically designated certain components as meeting ISO/TS16949 requirements, mainly for automotive use. In any case of use of non-designated products, TI will not be responsible for any failure to meet ISO/TS16949.

Products

Audio	www.ti.com/audio
Amplifiers	amplifier.ti.com
Data Converters	dataconverter.ti.com
DLP® Products	www.dlp.com
DSP	dsp.ti.com
Clocks and Timers	www.ti.com/clocks
Interface	interface.ti.com
Logic	logic.ti.com
Power Mgmt	power.ti.com
Microcontrollers	microcontroller.ti.com
RFID	www.ti-rfid.com
OMAP Applications Processors	www.ti.com/omap
Wireless Connectivity	www.ti.com/wirelessconnectivity

Applications

Automotive and Transportation	www.ti.com/automotive
Communications and Telecom	www.ti.com/communications
Computers and Peripherals	www.ti.com/computers
Consumer Electronics	www.ti.com/consumer-apps
Energy and Lighting	www.ti.com/energy
Industrial	www.ti.com/industrial
Medical	www.ti.com/medical
Security	www.ti.com/security
Space, Avionics and Defense	www.ti.com/space-avionics-defense
Video and Imaging	www.ti.com/video

TI E2E Community

e2e.ti.com

Looking for pricing, stock, or lifecycle information?

Click below to explore more details on WIN SOURCE:

 [View LM2792LDX-L on WIN SOURCE](#)

 [Texas Instruments](#) Information

Optimize Your Supply Chain with WIN SOURCE Solutions

-  Global Sourcing Solution
-  Obsolete Management
-  Cost Control Management
-  Shortage Management
-  Alternative Solution
-  Excess Inventory Management