

LM2724A High Speed 3A Synchronous MOSFET Driver

Check for Samples: [LM2724A](#)

FEATURES

- Shoot-Through Protection
- Input Under-Voltage-Lock-Out
- 3A Peak Driving Current
- 195 μ A Quiescent Current
- 28V Input Voltage in Buck Configuration
- SOIC-8 and WSON Packages

APPLICATIONS

- High Current DC/DC Power Supplies
- High Input Voltage Switching Regulators
- Fast Transient Microprocessors
- Notebook Computers

DESCRIPTION

The LM2724A is a dual N-channel MOSFET driver which can drive both the top and bottom MOSFETs in a push-pull structure simultaneously. The LM2724A takes a logic input and splits it into two complimentary signals with a typical 20ns dead time in between. The built-in cross-conduction protection circuitry prevents the top and bottom MOSFETs from turning on simultaneously. With a bias voltage of 5V, the peak sourcing and sinking current for each driver of the LM2724A is about 3A. Input UVLO (Under-Voltage-Lock-Out) ensures that all the driver outputs stay low until the supply rail exceeds the power-on threshold during system power on, or after the supply rail drops below power-on threshold by a specified hysteresis during system power down. The cross-conduction protection circuitry detects both driver outputs and will not turn on a driver until the other driver output is low. The top gate voltage needed by the top MOSFET is obtained through an external boot-strap structure. When not switching, the LM2724A only draws up to 195 μ A from the 5V rail. The synchronization operation of the bottom MOSFET can be disabled by pulling the SYNC pin to ground.

TYPICAL APPLICATION

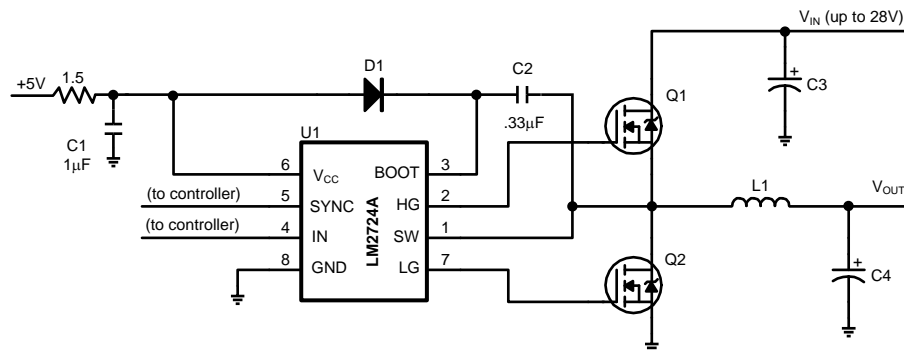

Please be aware that an important notice concerning availability, standard warranty, and use in critical applications of Texas Instruments semiconductor products and disclaimers thereto appears at the end of this data sheet.

All trademarks are the property of their respective owners.



These devices have limited built-in ESD protection. The leads should be shorted together or the device placed in conductive foam during storage or handling to prevent electrostatic damage to the MOS gates.

CONNECTION DIAGRAM

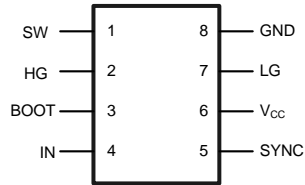

Figure 1. 8-Lead SOIC
See Package Number D

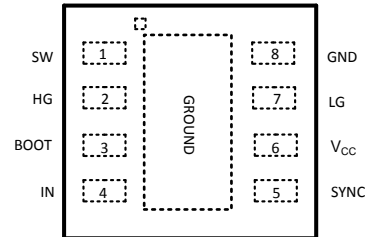
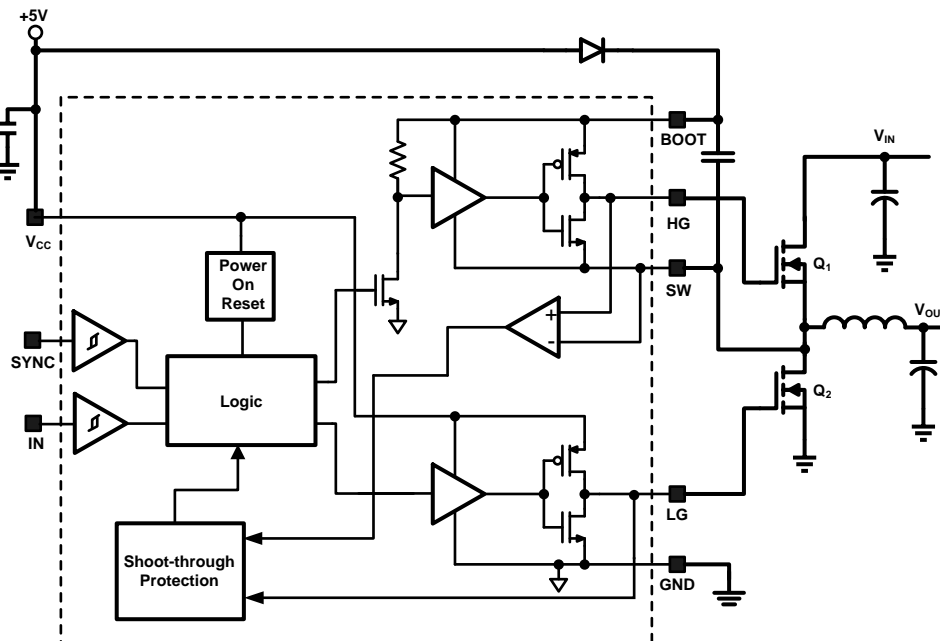

Figure 2. 8-Lead WSON
See Package Number NGN

PIN DESCRIPTIONS

Pin	Name	Function
1	SW	Top driver return. Should be connected to the common node of top and bottom FETs
2	HG	Top gate drive output. Should be connected to the top FET gate.
3	BOOT	Bootstrap. Accepts a bootstrap voltage for powering the high-side driver
4	IN	Accepts a logic control signal
5	SYNC	Bottom gate enable
6	V _{CC}	Connect to +5V supply
7	LG	Bottom gate drive output. Should be connected to the bottom FET gate.
8	GND	Ground

BLOCK DIAGRAM



ABSOLUTE MAXIMUM RATINGS⁽¹⁾⁽²⁾

		VALUE / UNITS
V _{CC}		7V
BOOT to SW		7V
BOOT to GND ⁽³⁾		35V
SW to GND ⁽⁴⁾		-2V to 30V
Junction Temperature		+150°C
Power Dissipation ⁽⁵⁾		720mW (SOIC-8) 3.2W (WSON-8)
Storage Temperature		-65°C to 150°C
ESD Susceptibility	Human Body Model ⁽⁶⁾	2.0 kV
Soldering Time, Temperature		10sec., 300°C

- (1) **Absolute Maximum Ratings** are limits beyond which damage to the device may occur. **Operating ratings** are conditions under which the device operates correctly. The ensured specifications apply only for the listed test conditions. Some performance characteristics may degrade when the part is not operated under listed conditions.
- (2) If Military/Aerospace specified devices are required, please contact the Texas Instruments Sales Office/Distributors for availability and specifications.
- (3) If BOOT voltage exceeds this value, the ESD structure will degrade.
- (4) The SW pin can have -2V to -0.5V applied for a maximum duty cycle of 10% with a maximum period of 1 second. There is no duty cycle or maximum period limitation for a SW pin voltage range of -0.5V to 30V.
- (5) Maximum allowable power dissipation is a function of the maximum junction temperature, T_{JMAX}, the junction-to-ambient thermal resistance, θ_{JA}, and the ambient temperature, T_A. The maximum allowable power dissipation at any ambient temperature is calculated using: P_{MAX} = (T_{JMAX} - T_A) / θ_{JA}. The junction-to-ambient thermal resistance, θ_{JA}, for LM2724A is 172°C/W. For a T_{JMAX} of 150°C and T_A of 25°C, the maximum allowable power dissipation is 0.7W. The θ_{JA}, for LM2724A WSON package is 39°C/W. For a T_{JMAX} of 150°C and T_A of 25°C, the maximum allowable power dissipation is 3.2W.
- (6) ESD machine model susceptibility is 200V.

RECOMMENDED OPERATING CONDITIONS⁽¹⁾

		VALUE / UNITS
V _{CC}		4.3V to 6.8V
Junction Temperature Range		-40°C to 125°C

- (1) **Absolute Maximum Ratings** are limits beyond which damage to the device may occur. **Operating ratings** are conditions under which the device operates correctly. The ensured specifications apply only for the listed test conditions. Some performance characteristics may degrade when the part is not operated under listed conditions.

Electrical Characteristics — LM2724A

$V_{CC} = \text{BOOT} = \text{SYNC} = 5\text{V}$, $\text{SW} = \text{GND} = 0\text{V}$, unless otherwise specified. Typicals and limits appearing in plain type apply for $T_A = T_J = +25^\circ\text{C}$. Limits appearing in **boldface** type apply over the entire operating temperature range.

Symbol	Parameter	Condition	Min	Typ	Max	Units
POWER SUPPLY						
I_{q_op}	Operating Quiescent Current	IN = 0V		145	195	μA
TOP DRIVER						
	Peak Pull-Up Current			3.0		A
	Pull-Up Rds_on	$I_{\text{BOOT}} = I_{\text{HG}} = 0.3\text{A}$		1.2		Ω
	Peak Pull-down Current			-3.2		A
	Pull-down Rds_on	$I_{\text{SW}} = I_{\text{HG}} = 0.3\text{A}$		0.5		Ω
t_4	Rise Time	Timing Diagram, $C_{\text{LOAD}} = 3.3\text{nF}$		17		ns
t_6	Fall Time			12		ns
t_3	Pull-Up Dead Time	Timing Diagram		19		ns
t_5	Pull-Down Delay	Timing Diagram, from IN Falling Edge		27		ns
BOTTOM DRIVER						
	Peak Pull-Up Current			3.2		A
	Pull-up Rds_on	$I_{VCC} = I_{LG} = 0.3\text{A}$		1.1		Ω
	Peak Pull-down Current			3.2		A
	Pull-down Rds_on	$I_{\text{GND}} = I_{LG} = 0.3\text{A}$		0.6		Ω
t_8	Rise Time	Timing Diagram, $C_{\text{LOAD}} = 3.3\text{nF}$		17		ns
t_2	Fall Time			14		ns
t_7	Pull-up Dead Time	Timing Diagram		22		ns
t_1	Pull-down Delay	Timing Diagram		13		ns
LOGIC						
$V_{\text{uvlo_up}}$	V_{CC} Under-Voltage-Lock-Out Upper Threshold	V_{CC} rises from 0V toward 5V			4	V
$V_{\text{uvlo_dn}}$	V_{CC} Under-Voltage-Lock-Out Lower Threshold	V_{CC} falls from 5V toward 0V	2.5			V
$V_{\text{uvlo_hys}}$	V_{CC} Under-Voltage-Lock-Out Hysteresis	V_{CC} falls from 5V toward 0V		0.8		V
$V_{\text{IH_SYNC}}$	SYNC Pin High Input		55%			V_{CC}
$V_{\text{IL_SYNC}}$	SYNC Pin Low Input				25%	
$I_{\text{leak_SYNC}}$	SYNC Pin Leakage Current	SYNC = 5V, Sink Current			2	μA
		SYNC = 0V, Source Current			10	
$I_{\text{leak_IN}}$	IN Pin Leakage Current	IN = 0V, Source Current			2	μA
		IN = 5V, Sink Current			10	
$t_{\text{on_min1}}$	Minimum Positive Pulse Width at IN Pin ⁽¹⁾			160		ns
$t_{\text{on_min2}}$	Minimum Positive Pulse Width at IN Pin for HG to Respond ⁽²⁾			45		
$t_{\text{on_min3}}$	Minimum Positive Pulse Width at IN Pin for LG to Respond ⁽³⁾			10		
$t_{\text{off_min1}}$	Minimum Negative Pulse Width at IN Pin for LG to Respond ⁽⁴⁾			40		
$t_{\text{off_min2}}$	Minimum Negative Pulse Width at IN Pin for HG to Respond ⁽⁵⁾			5		
$V_{\text{IH_IN}}$	IN High Level Input Voltage	When IN pin goes high from 0V	55%			V_{CC}
$V_{\text{IL_IN}}$	IN Low Level Input Voltage	When IN pin goes low from 5V			25%	

- (1) If the positive pulse width at IN pin is below this value but above $t_{\text{on_min2}}$, the pulse is internally stretched to $t_{\text{on_min1}}$, so the HG width will be a constant value.
- (2) If the positive pulse width at IN pin is below this value but above $t_{\text{on_min3}}$, then HG stops responding while LG still responds to the pulse.
- (3) If the positive pulse width at IN pin is below this value, the pulse will be completely ignored. Neither HG or LG will respond to it.
- (4) If the negative pulse width at IN pin is below this value but above $t_{\text{off_min2}}$, then LG stops responding while HG still responds.
- (5) If the negative pulse width at IN pin is below this value, the pulse will be completely ignored. Neither HG or LG will respond to it.

TIMING DIAGRAM

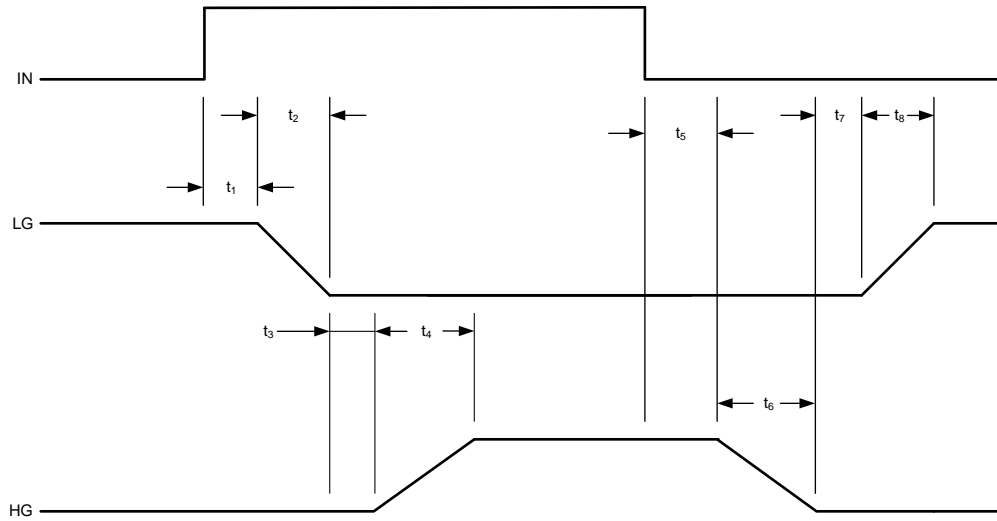

REVISION HISTORY

Changes from Revision B (March 2013) to Revision C	Page
• Changed layout of National Data Sheet to TI format	5

PACKAGING INFORMATION

Orderable Device	Status (1)	Package Type	Package Drawing	Pins	Package Qty	Eco Plan (2)	Lead/Ball Finish (6)	MSL Peak Temp (3)	Op Temp (°C)	Device Marking (4/5)	Samples
LM2724AMX/NOPB	NRND	SOIC	D	8	2500	Green (RoHS & no Sb/Br)	CU SN	Level-1-260C-UNLIM		2724 AM	

(1) The marketing status values are defined as follows:

ACTIVE: Product device recommended for new designs.

LIFEBUY: TI has announced that the device will be discontinued, and a lifetime-buy period is in effect.

NRND: Not recommended for new designs. Device is in production to support existing customers, but TI does not recommend using this part in a new design.

PREVIEW: Device has been announced but is not in production. Samples may or may not be available.

OBSELETE: TI has discontinued the production of the device.

(2) Eco Plan - The planned eco-friendly classification: Pb-Free (RoHS), Pb-Free (RoHS Exempt), or Green (RoHS & no Sb/Br) - please check <http://www.ti.com/productcontent> for the latest availability information and additional product content details.

TBD: The Pb-Free/Green conversion plan has not been defined.

Pb-Free (RoHS): TI's terms "Lead-Free" or "Pb-Free" mean semiconductor products that are compatible with the current RoHS requirements for all 6 substances, including the requirement that lead not exceed 0.1% by weight in homogeneous materials. Where designed to be soldered at high temperatures, TI Pb-Free products are suitable for use in specified lead-free processes.

Pb-Free (RoHS Exempt): This component has a RoHS exemption for either 1) lead-based flip-chip solder bumps used between the die and package, or 2) lead-based die adhesive used between the die and leadframe. The component is otherwise considered Pb-Free (RoHS compatible) as defined above.

Green (RoHS & no Sb/Br): TI defines "Green" to mean Pb-Free (RoHS compatible), and free of Bromine (Br) and Antimony (Sb) based flame retardants (Br or Sb do not exceed 0.1% by weight in homogeneous material)

(3) MSL, Peak Temp. - The Moisture Sensitivity Level rating according to the JEDEC industry standard classifications, and peak solder temperature.

(4) There may be additional marking, which relates to the logo, the lot trace code information, or the environmental category on the device.

(5) Multiple Device Markings will be inside parentheses. Only one Device Marking contained in parentheses and separated by a "~" will appear on a device. If a line is indented then it is a continuation of the previous line and the two combined represent the entire Device Marking for that device.

(6) Lead/Ball Finish - Orderable Devices may have multiple material finish options. Finish options are separated by a vertical ruled line. Lead/Ball Finish values may wrap to two lines if the finish value exceeds the maximum column width.

Important Information and Disclaimer:The information provided on this page represents TI's knowledge and belief as of the date that it is provided. TI bases its knowledge and belief on information provided by third parties, and makes no representation or warranty as to the accuracy of such information. Efforts are underway to better integrate information from third parties. TI has taken and continues to take reasonable steps to provide representative and accurate information but may not have conducted destructive testing or chemical analysis on incoming materials and chemicals. TI and TI suppliers consider certain information to be proprietary, and thus CAS numbers and other limited information may not be available for release.

In no event shall TI's liability arising out of such information exceed the total purchase price of the TI part(s) at issue in this document sold by TI to Customer on an annual basis.

TAPE AND REEL INFORMATION



QUADRANT ASSIGNMENTS FOR PIN 1 ORIENTATION IN TAPE



*All dimensions are nominal

Device	Package Type	Package Drawing	Pins	SPQ	Reel Diameter (mm)	Reel Width W1 (mm)	A0 (mm)	B0 (mm)	K0 (mm)	P1 (mm)	W (mm)	Pin1 Quadrant
LM2724AMX/NOPB	SOIC	D	8	2500	330.0	12.4	6.5	5.4	2.0	8.0	12.0	Q1

TAPE AND REEL BOX DIMENSIONS

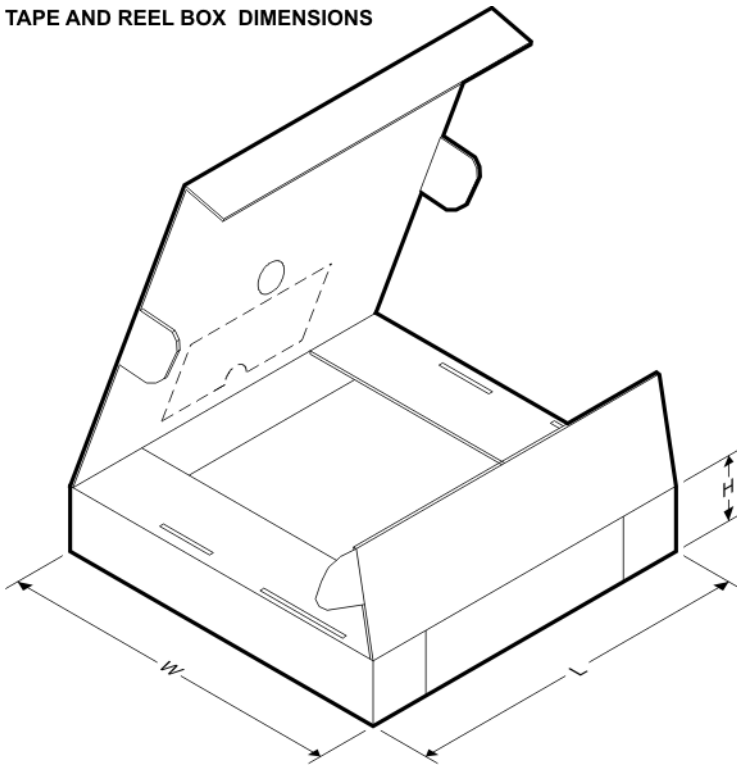

*All dimensions are nominal

Device	Package Type	Package Drawing	Pins	SPQ	Length (mm)	Width (mm)	Height (mm)
LM2724AMX/NOPB	SOIC	D	8	2500	367.0	367.0	35.0



D0008A

PACKAGE OUTLINE

SOIC - 1.75 mm max height

SMALL OUTLINE INTEGRATED CIRCUIT



4214825/C 02/2019

NOTES:

- Linear dimensions are in inches [millimeters]. Dimensions in parenthesis are for reference only. Controlling dimensions are in inches. Dimensioning and tolerancing per ASME Y14.5M.
- This drawing is subject to change without notice.
- This dimension does not include mold flash, protrusions, or gate burrs. Mold flash, protrusions, or gate burrs shall not exceed $.006$ [0.15] per side.
- This dimension does not include interlead flash.
- Reference JEDEC registration MS-012, variation AA.

EXAMPLE BOARD LAYOUT

D0008A

SOIC - 1.75 mm max height

SMALL OUTLINE INTEGRATED CIRCUIT



LAND PATTERN EXAMPLE
 EXPOSED METAL SHOWN
 SCALE:8X



SOLDER MASK DETAILS

4214825/C 02/2019

NOTES: (continued)

- 6. Publication IPC-7351 may have alternate designs.
- 7. Solder mask tolerances between and around signal pads can vary based on board fabrication site.

EXAMPLE STENCIL DESIGN

D0008A

SOIC - 1.75 mm max height

SMALL OUTLINE INTEGRATED CIRCUIT

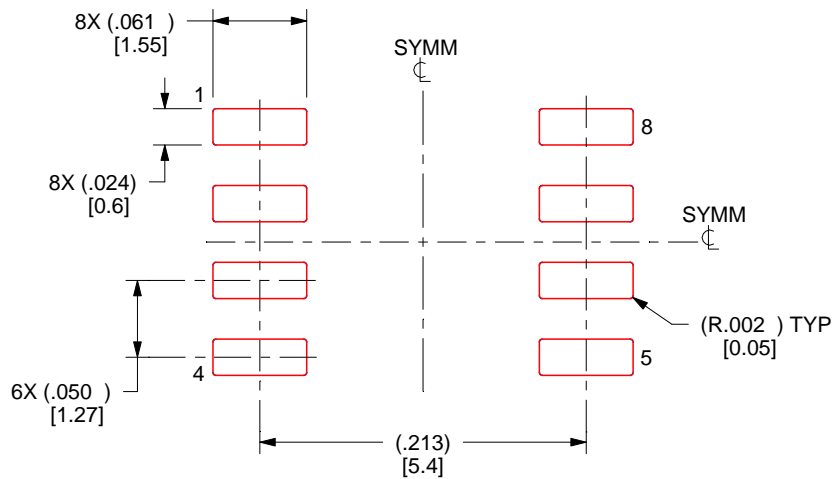

SOLDER PASTE EXAMPLE
BASED ON .005 INCH [0.125 MM] THICK STENCIL
SCALE:8X

4214825/C 02/2019

NOTES: (continued)

8. Laser cutting apertures with trapezoidal walls and rounded corners may offer better paste release. IPC-7525 may have alternate design recommendations.
9. Board assembly site may have different recommendations for stencil design.

IMPORTANT NOTICE AND DISCLAIMER

TI PROVIDES TECHNICAL AND RELIABILITY DATA (INCLUDING DATASHEETS), DESIGN RESOURCES (INCLUDING REFERENCE DESIGNS), APPLICATION OR OTHER DESIGN ADVICE, WEB TOOLS, SAFETY INFORMATION, AND OTHER RESOURCES "AS IS" AND WITH ALL FAULTS, AND DISCLAIMS ALL WARRANTIES, EXPRESS AND IMPLIED, INCLUDING WITHOUT LIMITATION ANY IMPLIED WARRANTIES OF MERCHANTABILITY, FITNESS FOR A PARTICULAR PURPOSE OR NON-INFRINGEMENT OF THIRD PARTY INTELLECTUAL PROPERTY RIGHTS.

These resources are intended for skilled developers designing with TI products. You are solely responsible for (1) selecting the appropriate TI products for your application, (2) designing, validating and testing your application, and (3) ensuring your application meets applicable standards, and any other safety, security, or other requirements. These resources are subject to change without notice. TI grants you permission to use these resources only for development of an application that uses the TI products described in the resource. Other reproduction and display of these resources is prohibited. No license is granted to any other TI intellectual property right or to any third party intellectual property right. TI disclaims responsibility for, and you will fully indemnify TI and its representatives against, any claims, damages, costs, losses, and liabilities arising out of your use of these resources.

TI's products are provided subject to TI's Terms of Sale (www.ti.com/legal/termsofsale.html) or other applicable terms available either on ti.com or provided in conjunction with such TI products. TI's provision of these resources does not expand or otherwise alter TI's applicable warranties or warranty disclaimers for TI products.

Mailing Address: Texas Instruments, Post Office Box 655303, Dallas, Texas 75265
Copyright © 2019, Texas Instruments Incorporated

Looking for pricing, stock, or lifecycle information?

Click below to explore more details on WIN SOURCE:

 [View LM2724M](#) on WIN SOURCE

 [Texas Instruments](#) Information

Optimize Your Supply Chain with WIN SOURCE Solutions

-  Global Sourcing Solution
-  Obsolete Management
-  Cost Control Management
-  Shortage Management
-  Alternative Solution
-  Excess Inventory Management