



# THE DATASHEET OF LM2512ASN



# LM2512A Mobile Pixel Link (MPL-1), 24-Bit RGB Display Interface Serializer with Optional Dithering and Look Up Table

Check for Samples: [LM2512A](#)

## FEATURES

- **24-bit RGB Interface Support up to 640 x 480 VGA Format**
- **Optional 24 to 18-bit Dithering**
- **Optional Look Up Table for Independent Color Correction**
- **MPL-1 Physical Layer**
- **SPI Interface for Look Up Table Control and Loading**
- **Low Power Consumption & Powerdown State**
- **Level Translation Between Host and Display**
- **Optional Auto Power Down on STOP PCLK**
- **Frame Sequence Bits Auto Resync upon Data or Clock Error**
- **1.6V to 2.0V Core / Analog Supply Voltage**
- **1.6V to 3.0V I/O Supply Voltage Range**

## SYSTEM BENEFITS

- **Dithered Data Reduction**
- **Independent RGB Color Correction**
- **24-bit Color Input**
- **Small Interface, Low Power and Low EMI**
- **Intrinsic Level Translation**

## DESCRIPTION

The LM2512A is a MPL Serializer (SER) that performs a 24-bit to 18-bit Dither operation and serialization of the video signals to Mobile Pixel link (MPL) levels on only 3 or 4 active signals. An optional Look Up Table (Three X 256 X 8 bit RAM) is also provided for independent color correction. 18-bit Bufferless or partial buffer displays from QVGA (320 x 240) up to VGA (640 x 480) pixels can utilize a 24-bit video source.

The interconnect is reduced from 28 signals to only 3 or 4 active signals with the LM2512A and companion deserializer easing flex interconnect design, size constraints and cost.

The LM2512A SER resides by the application, graphics or baseband processor and translates the wide parallel video bus from LVCMOS levels to serial Mobile Pixel Link levels for transmission over a flex cable (or coax) and PCB traces to the DES located near or in the display module.

When in Power\_Down, the SER is put to sleep and draws less than 10µA. The link can also be powered down by stopping the PCLK (DES dependant) or by the PD\* input pins.

The LM2512A provides enhanced AC performance over the LM2512. It implements the physical layer of the MPL-1 and uses a single-ended current-mode transmission.

## Typical 3 MD Lane Application Diagram - Bridge Chip

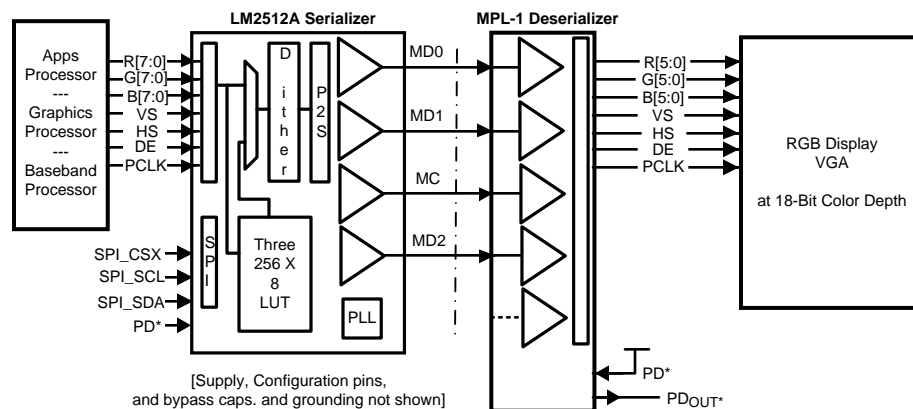

Please be aware that an important notice concerning availability, standard warranty, and use in critical applications of Texas Instruments semiconductor products and disclaimers thereto appears at the end of this data sheet.

All trademarks are the property of their respective owners.

### Pin Descriptions

Pin Name	No. of Pins	I/O, Type <sup>(1)</sup>	Description RGB Serializer
<b>MPL SERIAL BUS PINS</b>			
MD[2:0]	3	O, MPL	MPL Data Line Driver
MC	1	O, MPL	MPL Clock Line Driver
<b>SPI INTERFACE and CONFIGURATION PINS</b>			
SPI_CSX	1	I, LVCMOS	SPI_Chip Select Input SPI port is enabled when: SPI_CSX is Low, PD* is High, and PCLK is static.
SPI_SCL	1	I, LVCMOS	SPI_Clock Input
SPI_SDA/HS	1	IO, LVCMOS	Multi-function Pin: If SPI_CSX is Low, this is the SPI_SDA IO signal. Default is Input. Pin will be an output for a SPI Read transaction. See HS description below also.
PD*	1	I, LVCMOS	Power Down Mode Input SER is in sleep mode when PD* = Low, SER is enabled when PD* = High In PD*=L - Sleep mode: SPI interface is OFF, Register settings are <b>RESET</b> , and LUT data is retained.
RES1	1	I, LVCMOS	<b>Reserved 1 - Tie High (V<sub>DDIO</sub>) only available on NZK0049A package</b>
TM	1	I, LVCMOS	Test Mode <b>L = Normal Mode, tie to GND</b> H = Test Mode (Reserved)
NC	1	NA	Not Connected - Leave Open; only on NZK0049A package
<b>VIDEO INTERFACE PINS</b>			
PCLK	1	I, LVCMOS	Pixel Clock Input Video Signals are latched on the <b>RISING</b> edge.
R[7:0] G[7:0] B[7:0]	24	I, LVCMOS	RGB Data Bus Inputs – Bit 7 is the MSB.
VS	1	I, LVCMOS	Vertical Sync. Input <b>This signal is used as a frame start for the Dither block and is required.</b> The VS signal is serialized unmodified.
SPI_SDA/HS	1	IO, LVCMOS	Multi-function Pin: Horizontal Sync. Input (when SPI_CSX = High) See SPI_SDA description above also.
DE	1	I, LVCMOS	Data Enable Input
<b>POWER/GROUND PINS</b>			
V <sub>DDA</sub>	1	Power	Power Supply Pin for the PLL (SER) and MPL Interface. 1.6V to 2.0V
V <sub>DD</sub>	1	Power	Power Supply Pin for the digital core. 1.6V to 2.0V
V <sub>DDIO</sub>	3	Power	Power Supply Pin for the parallel interface I/Os. 1.6V to 3.0V
V <sub>SSA</sub>	1	Ground	Ground Pin for PLL (SER) and MPL interface
V <sub>SS</sub>	1	Ground	Ground Pin for digital core. For SN40A package, this is the large center pad.
V <sub>SSIO</sub>	4	Ground	Ground Pin for the parallel interface I/Os. For NJM0040A package, this is the large center pad.

(1) Note: I = Input, O = Output, IO = Input/Output. **Do not float input pins.**



These devices have limited built-in ESD protection. The leads should be shorted together or the device placed in conductive foam during storage or handling to prevent electrostatic damage to the MOS gates.

**ABSOLUTE MAXIMUM RATINGS** <sup>(1)(2)</sup>

Supply Voltage ( $V_{DDA}$ )		-0.3V to +2.2V
Supply Voltage ( $V_{DD}$ )		-0.3V to +2.2V
Supply Voltage ( $V_{DDIO}$ )		-0.3V to +3.3V
LVC MOS Input/Output Voltage		-0.3V to ( $V_{DDIO} + 0.3V$ )
MPL Output Voltage		-0.3V to $V_{DDA}$
Junction Temperature		+150°C
Storage Temperature		-65°C to +150°C
ESD Ratings:	HBM - JESD22-A114C std.	$\geq \pm 2$ kV
	MM - JESD22-A115-A std.	$\geq \pm 200$ V
	CDM - JESD22-C101-C std.	$\geq \pm 500$ V
Maximum Package Power Dissipation Capacity at 25°C	NZK0049A Package	2.5 W
	NJM0040A Package	3.2 W
	Derate NZK0049A Package above 25°C	25 mW/°C
	Derate NJM0040A Package above 25°C	26 mW/°C

- (1) "Absolute Maximum Ratings" are those values beyond which the safety of the device cannot be specified. They are not meant to imply that the device should be operated at these limits. The tables of "Electrical Characteristics" specify conditions for device operation.
- (2) If Military/Aerospace specified devices are required, please contact the Texas Instruments Sales Office/ Distributors for availability and specifications.

**RECOMMENDED OPERATING CONDITIONS**

		Min	Typ	Max	Units
Supply Voltage	$V_{DDA}$ to $V_{SSA}$ and $V_{DD}$ to $V_{SS}$	1.6	1.8	2.0	V
	$V_{DDIO}$ to $V_{SSIO}$	1.6		3.0	V
PClock Frequency (4X)		7.5		22.5	MHz
PClock Frequency (6X)		5		15	MHz
MC Frequency		30		90	MHz
Ambient Temperature		-30	25	85	°C

**ELECTRICAL CHARACTERISTICS**

 Over recommended operating supply and temperature ranges unless otherwise specified. <sup>(1)(2)</sup>

Symbol	Parameter	Conditions	Min	Typ	Max	Units
<b>MPL</b>						
$I_{OLL}$	Logic Low Current (5X $I_B$ )		3.947 $I_B$	5.0 $I_B$	6.842 $I_B$	$\mu$ A
$I_{OMS}$	Mid Scale Current			3.0 $I_B$		$\mu$ A
$I_{OLH}$	Logic High Current (1X $I_B$ )		0.711 $I_B$	1.0 $I_B$	1.368 $I_B$	$\mu$ A
$I_B$	Current Bias			190		$\mu$ A
$I_{OFF}$	MPL Leakage Current	$V_{MPL} = 0V$	-2		+2	$\mu$ A
<b>LVC MOS (1.6V to 3.0V Operation)</b>						
$V_{IH}$	Input Voltage High Level		0.7 $V_{DDIO}$		$V_{DDIO}$	V
$V_{IL}$	Input Voltage Low Level		GND		0.3 $V_{DDIO}$	V
$V_{HY}$	Input Hysteresis			100		mV
$I_{IN}$	Input Current		-1	0	+1	$\mu$ A
$V_{OH}$	Output Voltage High Level	SPI_SDA	$I_{OH} = -1$ mA	0.7 $V_{DDIO}$	$V_{DDIO}$	V
$V_{OL}$	Output Voltage Low Level		$I_{OL} = 1$ mA	$V_{SSIO}$	0.2 $V_{DDIO}$	V
<b>SUPPLY CURRENT</b>						

(1) Typical values are given for  $V_{DDIO} = 1.8V$  and  $V_{DD} = V_{DDA} = 1.8V$  and  $T_A = 25^\circ C$ .

(2) Current into a device pin is defined as positive. Current out of device pins is defined as negative. Voltages are referenced to Ground unless otherwise specified.

## ELECTRICAL CHARACTERISTICS (continued)

Over recommended operating supply and temperature ranges unless otherwise specified.<sup>(1)(2)</sup>

Symbol	Parameter	Conditions	Min	Typ	Max	Units
I <sub>DD</sub>	Total Supply Current - Enabled <sup>(3)</sup>	MC = 80 MHz, Checkerboard Pattern 3 MD Lane <sup>(4)</sup>	V <sub>DDIO</sub>	0.02	0.07	mA
			V <sub>DD</sub> /V <sub>DDA</sub>	5.4	9.0	mA
	Supply Current -Enabled	MC = 60 MHz, Checkerboard Pattern 2 MD Lane	V <sub>DDIO</sub>	0.01		mA
			V <sub>DD</sub> /V <sub>DDA</sub>	4.1		mA
I <sub>DDZ</sub>	Supply Current—Disable Power Down Modes Ta = 25°C	PD* = L	V <sub>DDIO</sub>	<1	2	μA
			V <sub>DD</sub> /V <sub>DDA</sub>	<1	5	μA
I <sub>DDZ</sub>	Supply Current—Disable Power Down Modes Ta = 25°C	Stop Clock	V <sub>DDIO</sub>	<1	2	μA
			V <sub>DD</sub> /V <sub>DDA</sub>	<1	5	μA

(3) For I<sub>DD</sub> tests - input signal conditions are: (swing, edge, freq, DE = H, VS = L, HS = L, RGB Checkerboard Pattern: AAAAAA-555555)

(4) Total Supply Current Conditions: checkerboard data pattern, 20MHz PCLK (3MDs), TYP V<sub>DDIO</sub> = V<sub>DDA</sub> = V<sub>DD</sub> = 1.8V, MAX VDDIO = 3.0V, MAX VDDA = VDD = 2.0V.

## SWITCHING CHARACTERISTICS

Over recommended operating supply and temperature ranges unless otherwise specified.<sup>(1)</sup>

Symbol	Parameter	Conditions	Min	Typ	Max	Units
<b>PARALLEL BUS TIMING</b>						
t <sub>SET</sub>	Set Up Time	SER Inputs <a href="#">Figure 1</a>	5			ns
t <sub>HOLD</sub>	Hold Time		5			ns
<b>SERIAL BUS TIMING</b>						
t <sub>DVBC</sub>	Serial Data Valid before Clock Edge	SER Data Pulse Width <a href="#">Figure 2</a> , <sup>(2)</sup> <sup>(3)</sup>	0.38			UI
t <sub>DVAC</sub>	Serial Data Valid after Clock Edge		0.38			UI
<b>POWER UP TIMING</b>						
t <sub>0</sub>	Bias Up Time	See <a href="#">Figure 9</a>		200		PCLK cycles
t <sub>1</sub>	MC Pulse Width LOW			200		PCLK cycles
t <sub>2</sub>	MC Pulse Width HIGH			20		PCLK cycles
t <sub>3</sub>	MC Pulse LOW			8		PCLK cycles
t <sub>4</sub>	MC Pulse LOW - SER PLL Lock Counter			600		PCLK cycles
t <sub>PZclk</sub>	Enable Time - Clock Start	PCLK to MC <sub>OUT</sub> <a href="#">Figure 4</a>		See <sup>(4)</sup>		
<b>MPL POWER OFF TIMING</b>						
t <sub>PAZ</sub>	Disable Time to Power Down	See <sup>(5)</sup>			15	ms
t <sub>PXZclk</sub>	Disable Time - Clock Stop	PCLK to MC <sub>OUT</sub> <a href="#">Figure 3</a>		2		PCLK cycles
<b>SPI INTERFACE</b>						

(1) Typical values are given for V<sub>DDIO</sub> = 1.8V and V<sub>DD</sub> = V<sub>DDA</sub> = 1.8V and T<sub>A</sub> = 25°C.

(2) 1 UI is the serial data MD pulse width = 1 / 8xPCLK (3 MD lanes), 1 UI is the serial data MD pulse width = 1 / 12xPCLK (2 MD lanes)

(3) This is a functional parameter and is specified by design or characterization.

(4) Enable Time is a complete MPL start up comprised of t<sub>0</sub> + t<sub>1</sub> + t<sub>2</sub> + t<sub>3</sub> + t<sub>4</sub>.

(5) Specified functionally by the I<sub>DDZ</sub> parameter. See also [Figure 10](#).

## SWITCHING CHARACTERISTICS (continued)

Over recommended operating supply and temperature ranges unless otherwise specified.<sup>(1)</sup>

Symbol	Parameter	Conditions	Min	Typ	Max	Units
t <sub>ACC</sub>	SPI Data Active (SDA_device)	See Figure 16	0		50	ns
t <sub>OHR</sub>	SPI Data Tri-State (SDA_device)		0		50	ns

## RECOMMENDED INPUT TIMING REQUIREMENTS (PCLK AND SPI)

Over recommended operating supply and temperature ranges unless otherwise specified.<sup>(1)</sup>

Symbol	Parameter	Conditions	Min	Typ	Max	Units	
<b>PIXEL CLOCK (PCLK)</b>							
f <sub>PCLK</sub>	Pixel Clock Frequency	3 MD Lane, (4X)	7.5		22.5	MHz	
		2 MD Lane, (6X)	5		15	MHz	
PCLK <sub>DC</sub>	Pixel Clock Duty Cycle		30	50	70	%	
t <sub>T</sub>	Transition Time	See <sup>(2)(3)</sup>	2	>2		ns	
t <sub>STOPpclk</sub>	Clock Stop Gap	See <sup>(4) (3)</sup>	4	2		PCLK cycles	
<b>SPI INTERFACE</b>							
f <sub>SCLw</sub>	SCL Frequency	WRITE			10	MHz	
f <sub>SCLr</sub>		READ			6.67	MHz	
t <sub>s0</sub>	CSX Set Time	See Figure 15	60			ns	
t <sub>s1</sub>	SI Set Time		30			ns	
t <sub>h1</sub>	SI Hold Time		30			ns	
t <sub>w1h</sub>	SCL Pulse Width High	WRITE	35			ns	
		READ	60			ns	
t <sub>w1l</sub>	SCL Pulse Width Low	WRITE	35			ns	
		READ	60			ns	
t <sub>r</sub>	SCL Rise Time	See Figure 15		5		ns	
t <sub>f</sub>	SCL Fall Time			5		ns	
t <sub>0H</sub>	SI Hold Time		30			ns	
t <sub>h0</sub>	CSX Hold Time		65			ns	
t <sub>w2</sub>	CSX OFF Time			100			ns

(1) Typical values are given for V<sub>DDIO</sub> = 1.8V and V<sub>DD</sub> = V<sub>DDA</sub> = 1.8V and T<sub>A</sub> = 25°C.

(2) Maximum transition time is a function of clock rate and should be less than 30% of the clock period to preserve signal quality.

(3) This is a functional parameter and is specified by design or characterization.

(4) This is the minimum time that the PCLK needs to be held off for in order for the device to be reset. Once PCLK is reapplied, a PLL Lock is required and start up sequence before video data is serialized.

**TIMING DIAGRAMS**

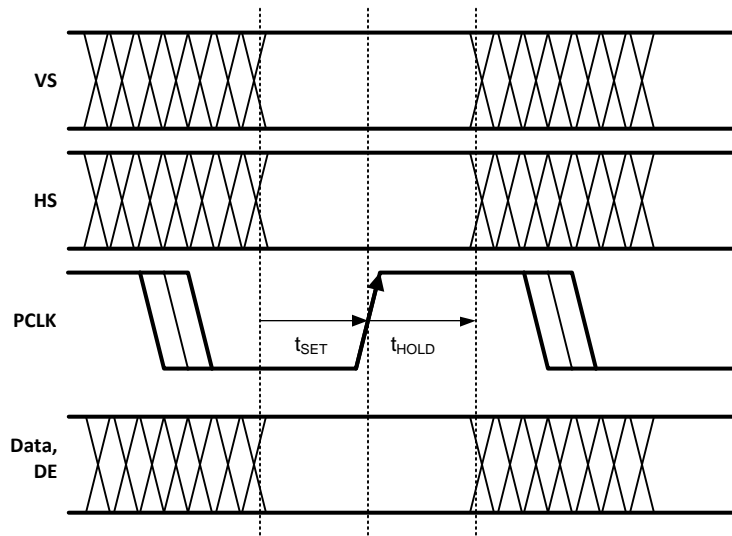

**Figure 1. Input Timing for RGB Interface**

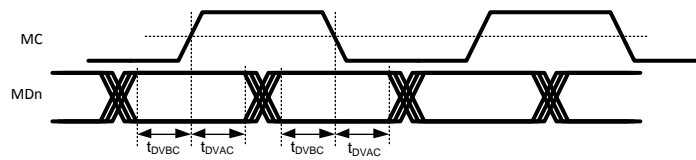

**Figure 2. Serial Data Valid**

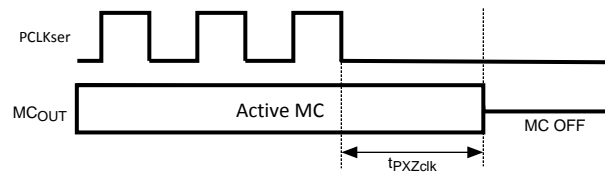

**Figure 3. Stop PClock Power Down**

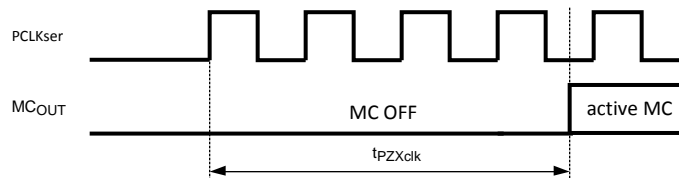

**Figure 4. Stop PClock Power Up**

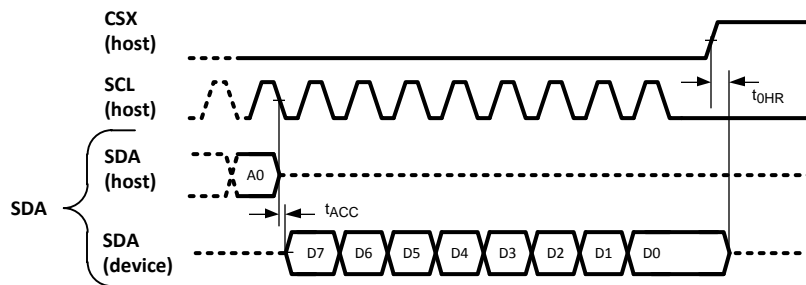
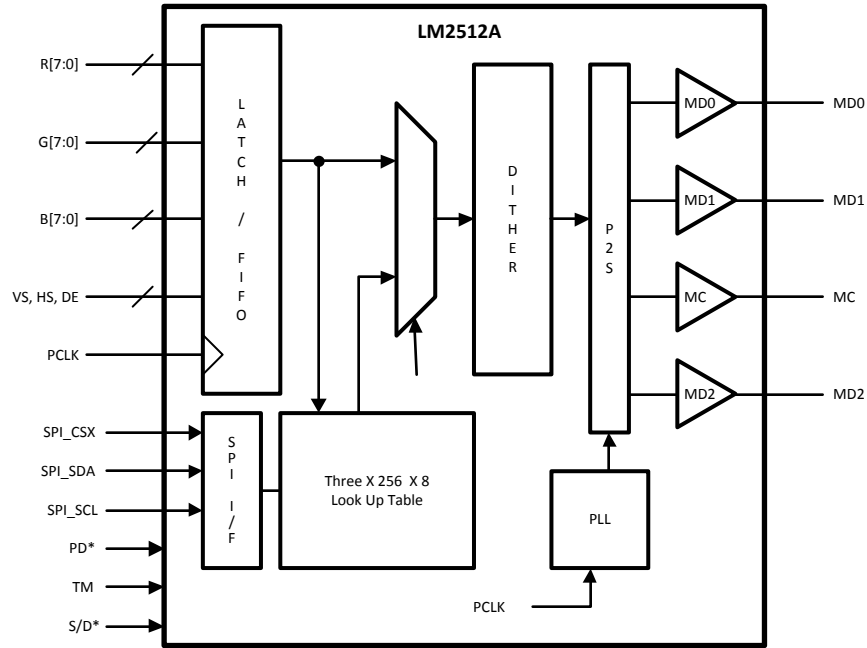

Figure 5. SPI Interface

**FUNCTIONAL DESCRIPTION**

The LM2512A is a Mobile Pixel Link (MPL) Serializer that serializes a 24-bit RGB plus three control signals (VS, HS, and DE) to two or three MPL MD lines plus the serial clock MC. Two options are provided: 24-bit RGB data dithering to 18 bits, and an optional Look Up Table. The three 256 X 8-bit RAMs may also be used and is controlled via a 3-wire SPI interface. The LM2512A is compatible with certain discrete MPL Deserializers and also Display Drivers with integrated MPL Deserializers (i.e. FPD95320).



**Figure 6. General LM2512A Block Diagram**

**BUS OVERVIEW**

The LM2512A is a multi-lane MPL Serializer that supports a 24-bit RGB source interface. The MPL physical layer is purpose-built for an extremely low power and low EMI data transmission while requiring the fewest number of signal lines. No external line components are required, as termination is provided internal to the MPL receiver. A maximum raw throughput of 480 Mbps (3-lane raw) is possible with this chipset. The MPL interface is designed for use with common 50Ω to 100Ω lines using standard materials and connectors. Lines may be microstrip or stripline construction. Total length of the interconnect is expected to be less than 20cm.

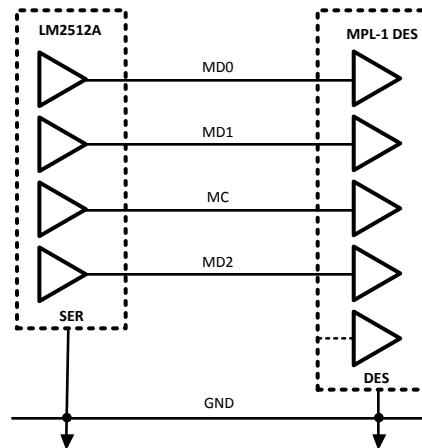

**Figure 7. Three MD Lane MPL Interface**

## SERIAL BUS TIMING

Data valid is relative to both edges of a RGB transaction as shown in [Figure 8](#). Data valid is specified as: Data Valid before Clock, Data Valid after Clock, and Skew between data lines should be less than 500ps.

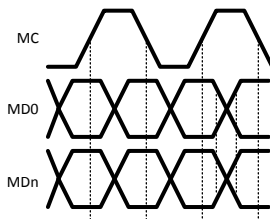

Figure 8. Dual Link Timing

## SERIAL BUS PHASES

There are three bus phases on the MPL serial bus. These are determined by the state of the MC and MD lines. The MPL bus phases are shown in [Table 1](#).

The LM2512A supports MPL Level 0 Enhanced Protocol with a Class 0 PHY.

Table 1. Link Phases<sup>(1)</sup>

Name	MC State	MDn State	Phase Description	Pre-Phase	Post-Phase
OFF (O)	0	0	Link is Off	A, or LU	LU
LINK-UP (LU)	0LHL	000L	Start Up Pulse	O	A or O
Active (A)	A	X	Streaming Data	LU	O

(1) **Notes on MC/MD Line State:**

- 0 = no current (off)
- L = Logic Low—The higher level of current on the MC and MD lines
- H = Logic High—The lower level of current on the MC and MD lines
- X = Low or High
- A = Active Clock

## SERIAL BUS START UP TIMING

In the Serial Bus OFF phase, SER line drivers for MDs and MC are turned off such that zero current flows over the MPL lines. On the SER side, when the PD\* input pin is de-asserted (driven High), or with PD\* = High and the PCLK is turned on, the SER will power up its bias block during t0.

The SER will next drive the MC line to the logic Low (5I current) state for 200 PCLK cycles (t1). The DES devices detects the current flowing in the MC line, and powers up its analog circuit blocks (or alternately is controlled by its PD\* input pin - device specific).

The SER then drives the MC line to a logic High (1I current) for 20 PCLK cycles (t2). On the MC low-to-high transition, the DES samples the current and optimizes its current sources to match that of the drivers.

The MC is now driven to a logic Low (5I current) for 8 PCLK cycles (t3).

Next the SER PLL is locked to the PCLK. A hold off counter of 600 PCLK cycles is used to hold off until the PLL has locked and is stable (t4). At this point, streaming RGB information is now sent across the MPL link.

Link-Up is shown in [Figure 9](#). The MC and MDn signals are current waveforms. Data at the DES output will appear a latency delay later.

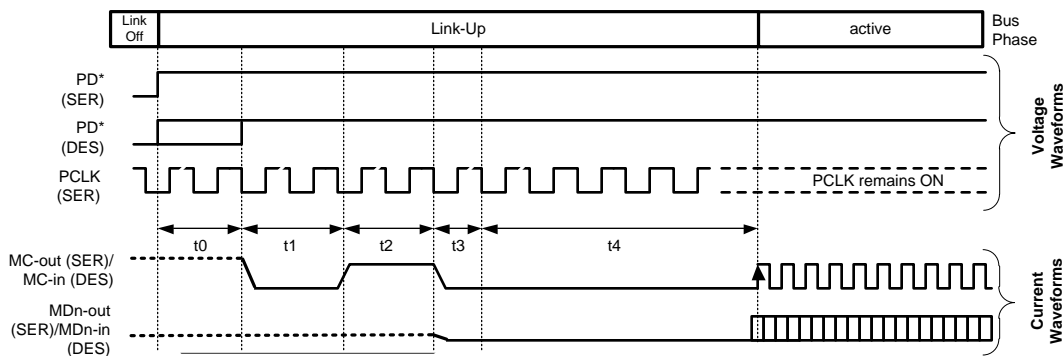

**Figure 9. MPL Power Up Timing**

## OFF PHASE

In the OFF phase, MPL transmitters are turned off with zero current flowing on the MC and MDn lines. Figure 10 shows the transition of the MPL bus into the OFF phase. If an MPL line is driven to a logical Low (high current) when the OFF phase is entered it may temporarily pass through as a logical High (low current) before reaching the zero line current state. The link may be powered down by asserting both the SER's and DES's PD\* input pins (Low) or by stopping the PCLK (DES dependant). This causes the devices to immediately put the link to the OFF Phase and internally enter a low power state.

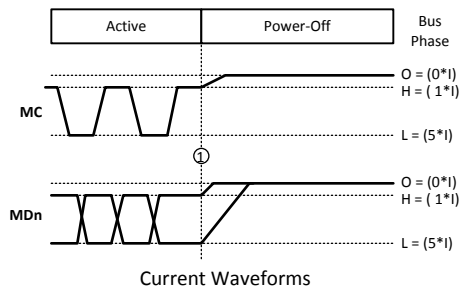

**Figure 10. Bus Power Down Timing**

## RGB VIDEO INTERFACE

The LM2512A is transparent to data format and control signal timing. Each PCLK, RGB inputs, HS, VS and DE are sampled on the rising edge of the PCLK. A PCLK by PCLK representation of these signals is duplicated on the opposite device after being transferred across the MPL Level-0 interface.

The LM2512A can accommodate a wide range of display formats. QVGA to VGA can be supported within the 2MHz to 20 MHz PCLK input range.

The 24-bit RGB (R0-7, G0-7, B0-7) color information is dithered to 18 bits then serialized, followed by the control bits VS (VSYNC), HS (HSYNC), DE (Data Enable) and PE (Odd Parity) and Frame Sequence (F[1:0]) bits.

The default configuration is for 2 MD lanes plus the MC. Via the SPI Interface, the Serializer can be configured for a 3 MD Lane configuration.

When transporting color depth below 24-bit, the 24-bit protocol can be used by offsetting the color data. The LSBs of the RGB are not used and data is offset toward the upper (MSB) end of the bit fields. Unused inputs should be tied off.

At a maximum PCLK of 20 MHz (3MDs), a 80MHz MC clock is generated. The data lane rate uses both clock edges, thus 160Mbps (raw) are sent per MD lane.

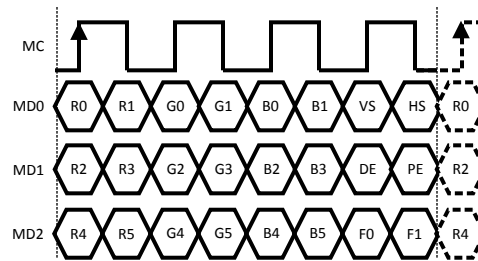

Figure 11. 24-bit to 18-bit Dithered, 3 MD Lane, RGB Transaction

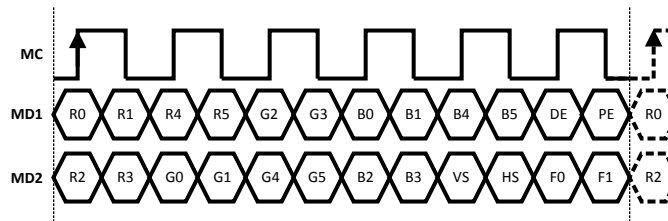

Figure 12. 24-bit to 18-bit Dithered, 2 MD Lane (Default), RGB Transaction (NOTE MD1 and MD2)

### Serial Payload Parity Bit

Odd Parity is calculated on the RGB bits, control (VS, HS, and DE) bits and F0, F1 bits and then sent from the SER to the DES via the serial PE bit. This is included for compatibility with certain MPL Deserializers.

### Synchronization Detect and Recovery

If a data error or clock slip error occurs over the MPL link, the RGB MPL Deserializer can detect this condition and recover from it. The method chosen is a data transparent method, and has very little overhead because it does not use a data expansion coding method. For the Dithered 18-bit color transaction, it uses two bits that are already required in the 4 MC cycle transaction. Total overhead for each pixel is 3/24 or 12.5%.

The LM2512A MPL RGB Serializer simply increments the two bit field F[1:0] on every pixel (MPL frame) transmitted. Therefore every four MPL frames, the pattern will repeat. It is very unlikely that this pattern would be found within the payload data, and if it were found, the probability that it would repeat for many frames becomes infinitely small. This code is used by the MPL Deserializer to detect any frame alignment problems and quickly recover.

The RGB MPL Deserializer, upon a normal power up sequence, starts in the proper synchronization. If synchronization is lost for any reason, it searches for the incrementing pattern. Once found, it resynchronizes the output pixel data and timing signals. See MPL DES Datasheet for details on how the specific DES handles the Frame Sequence.

### OPTIONAL DITHERING FEATURE

The LM2512A is a 2 or 3-Lane MPL Serializer, 24-bit RGB input data (8-bits/color channel) is internally dithered to 18-bits (6-bits/color channel) using a high-quality stochastic dithering process. This process has a "blue noise" characteristic that minimizes the visibility of the dither patterns. The resulting data stream of 18-bit data is then serialized and transmitted via MPL.

**The Dither circuitry requires the VS control signal for proper operation.** This signal is used to generate an internal signal that marks the start of the (video) frame. The serializer samples and sends the VS information unmodified.

Dithering parameters are controlled by two registers. When the dithering is bypassed, only RGB[7:2] is serialized and transmitted for 18-bit input RGB [5:0] (MSB aligned). RGB[1:0] should not be connected and the unused input should be tied low; do not leave input open.

## OPTIONAL LOOK UP TABLE AND SPI INTERFACE

Three 256 X 8-bit SRAMs provide a Look Up Table for independent color correction. The LUT is disabled by default and also after a device PD\* cycle. The PD\* cycle can be entered via the PD\* input pin directly, or by stopping the PCLK. Before using the LUT, the SRAM must be loaded with its contents. If power is cycled to the device, the LUT must be loaded again.

To enable the LUT:

1. Select/Unlock the LM2512A SPI Interface - Write FF'h to REG22 (16'h)
2. Write the LUT contents to the SRAM using Writes or Page Writes
3. Enable the LUT - Write a 01'h to REG0 (00'h)
4. De-Select/Lock the LM2512A SPI interface -Write 00'h to REG22 (16'h)

When waking up the LM2512A from the power down mode (PD\*=L), the LUT needs to be enabled if it is desired. Contents to the SRAM are still held and valid.

1. Select/Unlock the LM2512A SPI Interface - Write FF'h to REG22 (16'h)
2. Enable the LUT - Write a 01'h to REG0 (00'h)
3. Optional -select Lane Scale if not using default
4. De-Select/Lock the LM2512A SPI interface -Write a 00'h to REG22 (16'h)

If power is cycled to the device, the LUT SRAMs must be loaded again.

### SPI Interface

The Serial Peripheral Interface (SPI) allows control over various aspects of the LM2512A, the Look Up Table operation, and access to the three 256 x 8-RAM blocks. There are 9 defined registers in the device. Three SPI transactions are supported, which are: 16-bit WRITE, PAGE WRITE, and a 16-bit READ. The SPI interface is disabled when the device is in the sleep mode (via PCLK Stop or by PD\* = L). The SPI interface may be used when PD\* = H.

### 16-bit WRITE

The 16-bit WRITE is shown in [Figure 15](#). The SDA payload consists of a "0" (Write Command), seven address bits and eight data bits. The CSX signal is driven Low, and 16-bits of SDA (data) are sent to the device. Data is latched on the rising edge of the SCL. After each 16-bit WRITE, CSX must return HIGH.

**Table 2. 16-bit WRITE – SPI**

Bit	B15	B14	B13	B12	B11	B10	B9	B8	B7	B6	B5	B4	B3	B2	B1	B0
SDA	0	A6	A5	A4	A3	A2	A1	A0	D7	D6	D5	D4	D3	D2	D1	D0

### 16-bit READ

The 16-bit READ is shown in [Figure 16](#). The SDA payload consists of a "1" (Read Command), seven address bits and eight data bits which are driven from the device. The CSX signal is driven Low, and the host drives the first 8 bits of the SDA ("1" and seven address bits), the device then drives the respective 8 bits of the data on the SDA signal.

**Table 3. 16-bit READ – SPI**

Bit	B15	B14	B13	B12	B11	B10	B9	B8	B7	B6	B5	B4	B3	B2	B1	B0
SDA	1	A6	A5	A4	A3	A2	A1	A0	<b>D7</b>	<b>D6</b>	<b>D5</b>	<b>D4</b>	<b>D3</b>	<b>D2</b>	<b>D1</b>	<b>D0</b>

### PAGE WRITE

The PAGE WRITE is shown in [Figure 17](#). The SDA payload consists of a "0" (Write Command), seven address bits of the start address and then the consecutive data bytes. 256 bytes maximum can be sent. The CSX signal is driven Low, and the host drives the SDA signal with a "0" (Write Command), the seven start address bits and the variable length data bytes. The Page Write is denoted by the CSX signal staying low while the data bytes are streamed. Data is latched on the rising edge of the SCL.

**Table 4. PAGE WRITE**

Bit	B15	B14	B13	B12	B11	B10	B9	B8	B7	B6	B5	B4	B3	B2	B1	B0
SDA	0	A6	A5	A4	A3	A2	A1	A0	D7	D6	D5	D4	D3	D2	D1	D0
	(start address)								(Data Byte 0)							
	D7	D6	D5	D4	D3	D2	D1	D0	D7	D6	D5	D4	D3	D2	D1	D0
	(Data Byte 1)								(Data Byte n, 256 max.)							

There are three SPI Interface signals: CSX - SPI Chip Select, SCL - SPI Clock, and SDA - SPI Data. CSX and SCL are inputs on the LM2512A. SDA is a bi-directional Data line and is an input for a WRITE and an output for the READ\_DATA portion of a READ operation. READs are optional and are not required. Due to the Select/Unlock – De-Select/Lock feature of the device the SPI interface may be shared with the display driver. Several connection configurations are possible. A couple examples are shown in [Figure 13](#) and [Figure 14](#).

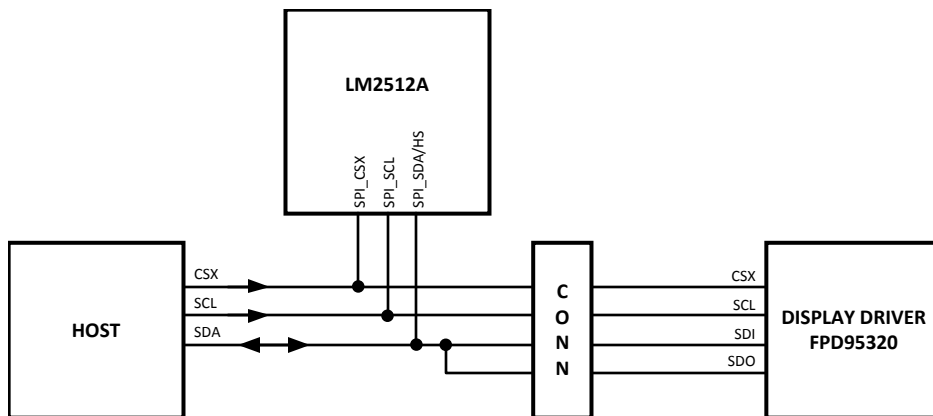

**Figure 13. LM2512A WRITE & READ to 3-signal SPI HOST**

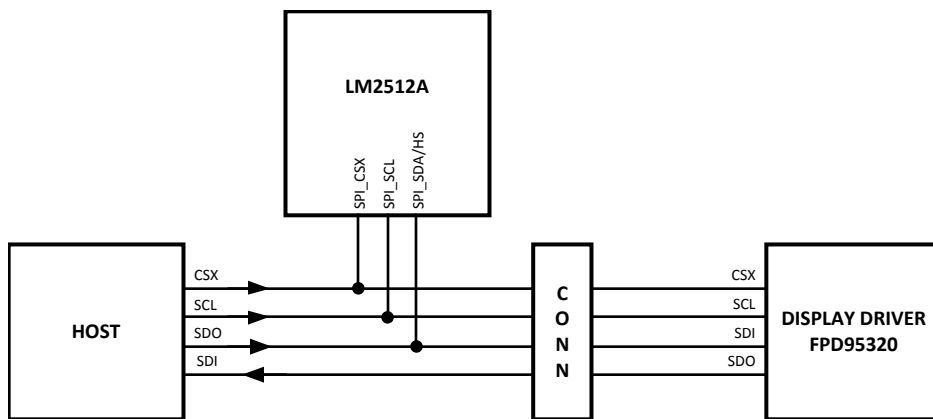

**Figure 14. LM2512A WRITE only to 4-signal SPI HOST**

**Table 5. LM2512A SPI Registers**

Name	Addresses	Type <sup>(1)</sup>	Description	Default
Command	0x00	R/W	Bit 0 = LUT Enable 0'b = LUT Disabled, 1'b = LUT Enabled Bit 4 = Special Register Access 0'b = SRA Locked, 1'b = SRA Unlocked For access to Registers 0x01, 0x08, 0x09, 0x0A, the Special Register Access bit must be unlocked. Must write all 8 bits.	00'h
Configuration <sup>(2)</sup>	0x01	R/W	Bit 4 = MPL Edge Rate 0'b = normal edge, 1'b = slow edge All other bits reserved, must be written as 0s.	00'h
Red RAM Address	0x02	R/W	Red Address	00'h
Red RAM Data	0x03	R/W	Red Data	XX'h
Green RAM Address	0x04	R/W	Green Address	00'h
Green RAM Data	0x05	R/W	Green Data	XX'h
Blue RAM Address	0x06	R/W	Blue Address	00'h
Blue RAM Data	0x07	R/W	Blue Data	XX'h
Dither Configuration1 <sup>(2)</sup>	0x08	R/W	Bit 0 - Dither Bypass 1'b = Bypass Dither, 0'b = Dither ON Bit 1 - DE INV 1'b = Active Low DE, 0'b = Active High DE Does not alter DE signal, dither block input only. Bit 2 - VS INV 1'b = Active Low VS signal, 0'b = Active High VS signal. Does not alter VS signal, dither block input only. Bit 3 - Reserved Bit 4 - Tempen0 1'b = Transposed Dither Pattern, 0'b = Even and odd frames use same dither pattern Bit 5 - Tempen1 1'b = Temporal Dithering is Enabled, 0'b = Disabled Bit 6 - Dith3 - Dither Amplitude 1'b = set to 3 bits, 0'b = set to 4 bits Bit 7 - Reserved	61'h
Dither Configuration2 <sup>(2)</sup>	0x09	R/W	Dither Parameter <b>Reserved</b> , Default value recommended.	67'h
Lane Scale <sup>(2) (3)</sup>	0x0A	W	Bit[2:0] 000'b = Reserved 010'b = 2 MD Lanes (Default) 100'b = 3 MD Lanes all others = Reserved	02'h
<b>Reserved</b> <sup>(4)</sup>	0x0B-0x15	na	<b>Reserved</b>	
Device Select (Unlock/Lock)	0x16	R/W	0xFF'h enables LM2512A SPI All other values disables LM2512A SPI (0x00 to 0xFE)	00'h
<b>Reserved</b> <sup>(4)</sup>	0x17-0x7F	na	<b>Reserved</b>	

- (1) If a WRITE is done to a reserved bits, data should be all 0's. If a READ is done to a reserved location, either 1's or 0's may be returned. Mask reserved data bits.
- (2) This register must be unlocked first through bit 4 of register 0.
- (3) WRITE ONLY Register, read of this register is not supported.
- (4) DO NOT write to Reserved Registers.

## SPI Timing

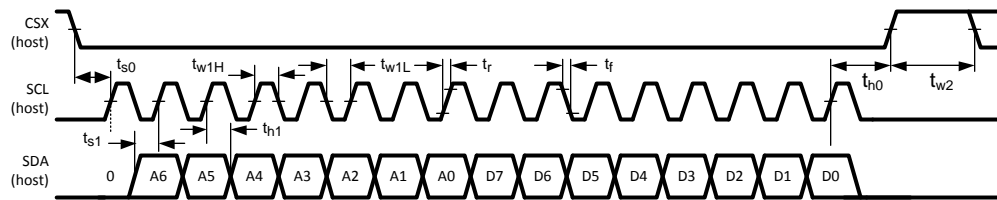

Figure 15. 16-bit SPI WRITE

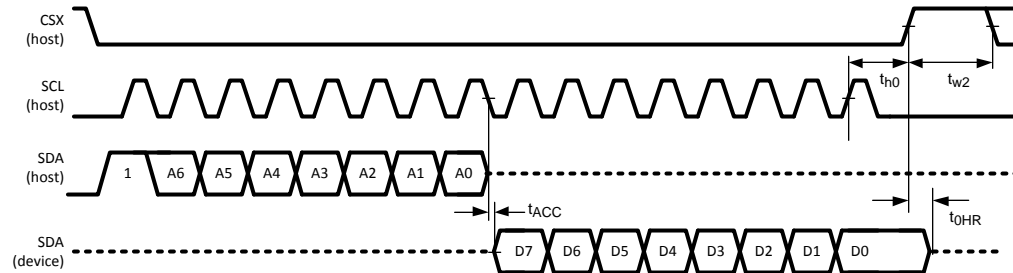

Figure 16. 16-bit SPI READ

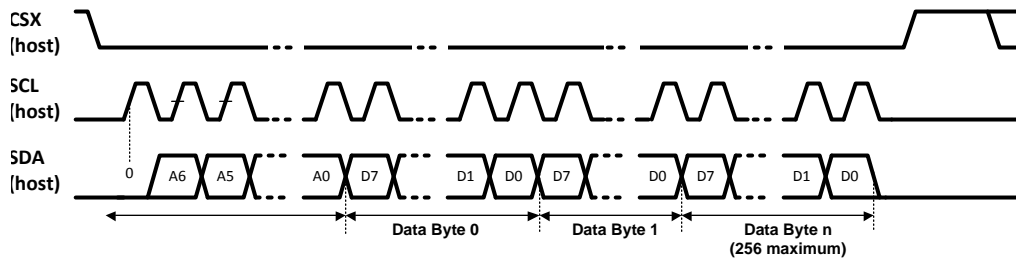

Figure 17. SPI PAGE WRITE

## Power Up Sequence

The MPL Link must be powered up and enabled in a certain sequence for proper operation of the link and devices. The following list provides the recommended sequence:

1. Apply Power (See [Power Supply](#) Section)
2. PD\* Input should be held low until Power is stable and within specification and PCLK is driven to a static level.
3. PD\* is driven HIGH, SPI interface is now available.
4. To program the device via the SPI interface:
  - Select / Unlock the LM2512A, Write FF'h to REG 16'h
  - LUT registers are now accessible
  - If Lane Scale Register needs to be modified, this is accessed through bit 4 of the Command register.
  - A write to REG 16'h on any other value besides FF'h will de-select / lock the LM2512A's SPI

- SPI Commands **MUST** be completed before the PCLK is active.
- 5. Condition the DES as required
- 6. Start PCLK, after the DES is calibrated and the SER PLL Locked, streaming data transmission will occur.

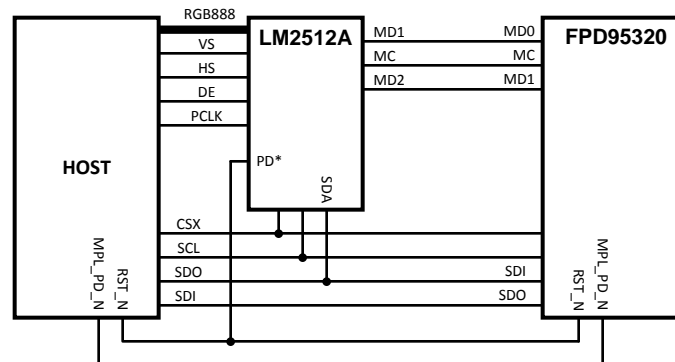

**Figure 18. Typical Application Connection Diagram**

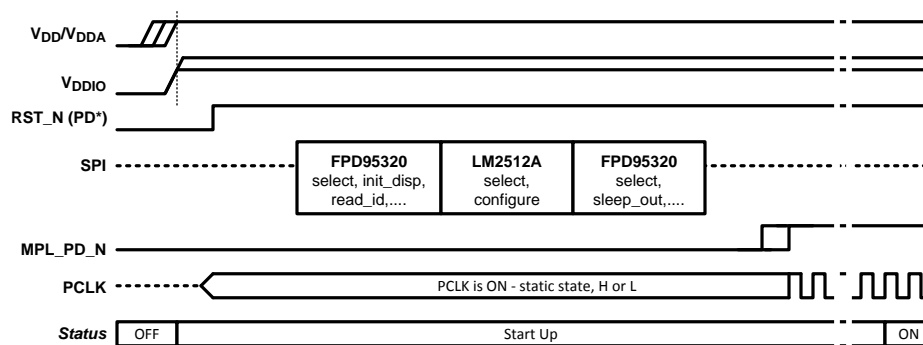

**Figure 19. Power Up Sequence**

A typical connection diagram is shown in [Figure 18](#). The LM2512A SPI is configured to support write only transactions in this example. The FPD95320 can support both writes and reads on its SPI interface. [Figure 19](#) shows a typical power up sequence using the shared SPI interface. Power is brought up first. The RST\_N signal is held low until power to the FPD95320 (not shown) and the LM2512A is stable and within specifications. Next the RST\_N signal is driven High, which allows access to the SPI interfaces. The PCLK should also be turned on and held at a static level (High or Low). The FPD95320 is selected first via a write to register 16'h and the display is initialized. Next a write of FF'h to register 16'h. This command will Lock the FPD95320 SPI interface and Select / Unlock the LM2512A SPI interface. By default, the LM2512A powers up in 2 MD lanes with the Dither and the LUT disabled. The Look-up Table - LUT is accessible by enabling bit 0 of the command register 00'h. The Special Register Access - SRA are also accessible for lane scaling by enabling bit 4 of the command register 00'h. To enable the LUT and unlock SRA, write of 11'h to register 00'h (see [Table 5](#)). To change to 3 MD lanes, write of 04'h to register 0A'h. Next additional commands are sent to the FPD95320 by issuing a Unlock command to the FPD95320 register 16'h which also de-selects / locks the LM2512A SPI. After the SPI commands are completed, the MPL\_PD\_N signal is driven High to arm the Deserializer for the MPL start sequence. The PCLK is started up, and the SER will calibrate the DES and lock to the incoming PCLK signal. Once this is completed, video data transmission occurs and the link is ON.

## Application Configurations

Many different application configurations are possible with the flexible LM2512A Serializer. These include:

- LM2512A - 2 MD Lane to FPD95320 Display Driver
- LM2512A - 2 MD Lane to LM2506 DES
- LM2512A - 3 MD Lane - Reserved for future use

Take care in reviewing the MPL signals and serial bit mapping to ensure proper connection between the devices.

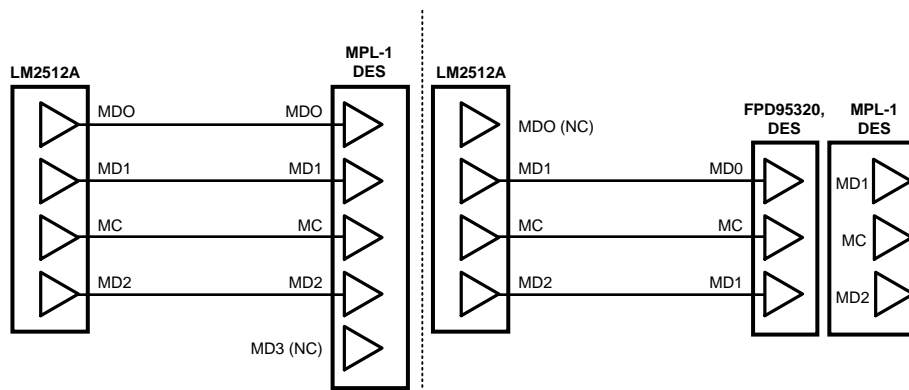

Figure 20. Application Configurations

## LM2512A OPERATION

### POWER SUPPLIES

The  $V_{DD}$  and  $V_{DDA}$  (MPL and PLL) must be connected to the same potential between 1.6V and 2.0V.  $V_{DDIO}$  powers the logic interface and may be powered between 1.6V and 3.0V to be compatible with a wide range of host and target devices.

$V_{DD}/V_{DDA}$  should be powered ON at the same time as  $V_{DDIO}$  or before.  $V_{DDIO}$  then  $V_{DD}/V_{DDA}$  is not recommended.

### BYPASS RECOMMENDATIONS

Bypass capacitors should be placed near the power supply pins of the device. Use high frequency ceramic (surface mount recommended) 0.1  $\mu$ F capacitors. A 2.2 to 4.7  $\mu$ F Tantalum capacitor is recommended near the SER  $V_{DDA}$  pin for PLL bypass. Connect bypass capacitors with wide traces and use dual or larger via to reduce resistance and inductance of the feeds. Utilizing a thin spacing between power and ground planes will provide good high frequency bypass above the frequency range where most typical surface mount capacitors are less effective. To gain the maximum benefit from this, low inductance feed points are important. Also, adjacent signal layers can be filled to create additional capacitance. Minimize loops in the ground returns also for improved signal fidelity and lowest emissions.

### UNUSED/OPEN PINS

Unused inputs **must** be tied to the proper input level—do not float them.

### PHASE-LOCKED LOOP

A PLL is enabled to generate the serial link clock. The Phase-locked loop system generates the serial data clock at 4X or 6X of the input clock depending upon the number of MD Lanes selected. The MC rate is limited to 80 MHz for this enhanced Class 0 MPL PHY.

### POWER DOWN/OFF CONFIGURATION / OPTIONS AND CLOCK STOP

The LM2512A (SER) can be controlled by it's PD\* input pin or via a auto power down mode that monitors the PCLK input signal.

For PD\* Input Power Down control, a GPO signal from the host is used to enable and disable the LM2512A and the DES. The LM2512A is enabled when the PD\* input is High and disabled when the PD\* input is Low.

When using the auto power down mode, the PD\* input needs to be held High. When the PCLK is held static, the SER will detect this condition and power down. When the PCLK is restarted, the SER powers up, The DES is calibrated, and the PLL locks to the incoming clock signal. Once this is complete, video data transmission can occur. See [Figure 3](#), [Figure 4](#), and [Figure 9](#). The stopping of the pixel clock should be done cleanly. The minimum clock stop gap should be at least 4 PCLK cycles wide. Floating of the PCLK input pin is not recommended. Consult the MPL DES datasheet to determine requirements that the DES requires.

### LM2512A vs LM2512

The following list provides the differences between the LM2512 and the enhanced LM2512A.

- Increased Idata Current
- Enhanced Current Matching
- Enhanced MC Duty Cycle
- 2 MD Lane Default Configuration
- Dither Off Default
- LUT Default State ( $I_{DDZ}$ )
- MPL Driver Edge Rate Control Option

## APPLICATION INFORMATION

### SYSTEM BANDWIDTH CALCULATIONS

For a HVGA (320 X 480) application with the following assumptions: 60 Hz +/-5% refresh rate, 10% blanking, RGB666, and 2 MD Lanes and following calculations can be made:

Calculate PCLK -  $320 \times 480 \times 1.1 \times 60 \times 1.05 = 10.6$  MHz PCLK

Calculate MC rate - since the application is 2 MD lanes, PCLK X 6 is the MC rate or 63.87 MHz. Also check that this MC rate does not exceed the MC maximum rate for the chipset.

Calculate MD rate - MPL uses both edges of the MC to send serialized data, thus data rate is 2X the MC rate, or 127.7 Mbps per MD lane in our example.

Calculate the application throughput - using 2 MD lanes, throughput is 2 X of the MD rate or 255.5 Mbps of raw band width.

For a VGA (640 X 480) application with the following assumptions: 55 Hz +/-5% refresh rate, 10% blanking, RGB666, and 3 MD Lanes and following calculations can be made:

Calculate PCLK -  $640 \times 480 \times 1.1 \times 55 \times 1.05 = 19.5$  MHz PCLK

Calculate MC rate - since the application is 3 MD lanes, PCLK X 4 is the MC rate or 78.1 MHz. Also check that this MC rate does not exceed the MC maximum rate for the chipset.

Calculate MD rate - MPL uses both edges of the MC to send serialized data, thus data rate is 2X the MC rate, or 156 Mbps per MD lane in our example.

Calculate the application throughput - using 3MD lanes, throughput is 3X of the MD rate or 468 Mbps of raw band width.

### SYSTEM CONSIDERATIONS

When employing the MPL SER/DES chipset in place of a parallel video bus, a few system considerations must be taken into account. Before sending video data to the display, the SER/DES must be ready to transmit data across the link. The MPL link must be powered up, and the PLL must be locked and the DES calibrated.

### FLEX CIRCUIT RECOMMENDATIONS

The MPL lines should generally run together to minimize any trace length differences (skew). For impedance control and also noise isolation (crosstalk), guard ground traces are recommended in between the signals. Commonly a Ground-Signal-Ground (GSGSGSG) layout is used. Locate fast edge rate and large swing signals further away to also minimize any coupling (unwanted crosstalk). In a stacked flex interconnect, crosstalk also needs to be taken into account in the above and below layers (vertical direction). To minimize any coupling locate MPL traces next to a ground layer. Power rails also tend to generate less noise than LVCMOS so they are also good candidates for use as isolation and separation.

The interconnect from the SER to the DES typically acts like a transmission line. Thus impedance control and ground returns are an important part of system design. Impedance should be in the 50 to 100 Ohm nominal range for the LM2512A. Testing has been done with cables ranging from 40 to 110 Ohms without error (BER Testing). To obtain the impedance, adjacent grounds are typically required (1 layer flex), or a ground shield / layer. Total interconnect length is intended to be in the 20cm range, however 30cm is possible at lower data rates. Skew should be less than 500ps to maximize timing margins.

**GROUNDING**

While the LM2512A employs three separate types of ground pins, these are intended to be connected together to a common ground plane. The separate ground pins help to isolate switching currents from different sections of the integrated circuit (IC). Also required is a nearby signal return (ground) for the MPL signals. These should be provided next to the MPL signals, as that will create the smallest current loop area. The grounds are also useful for noise isolation and impedance control.

**PCB RECOMMENDATIONS**

General guidelines for the PCB design:

- Floor plan, locate MPL SER near the connector to limit chance of cross talk to high speed serial signals.
- Route serial traces together, minimize the number of layer changes to reduce loading.
- Use ground lines as guards to minimize any noise coupling (specifies distance).
- Avoid parallel runs with fast edge, large LVCMOS swings.
- Also use a GSGSG pinout in connectors (Board to Board or ZIF).
- DES device - follow similar guidelines.
- Bypass the device with MLC surface mount devices and thinly separated power and ground planes with low inductance feeds.
- High current returns should have a separate path with a width proportional to the amount of current carried to minimize any resulting IR effects.

**CONNECTION DIAGRAM 49 NFBGA PACKAGE**

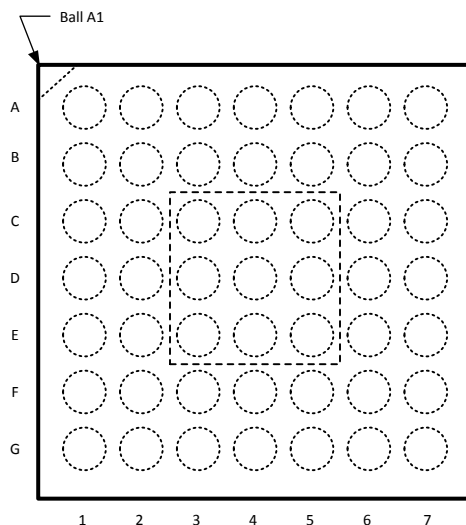
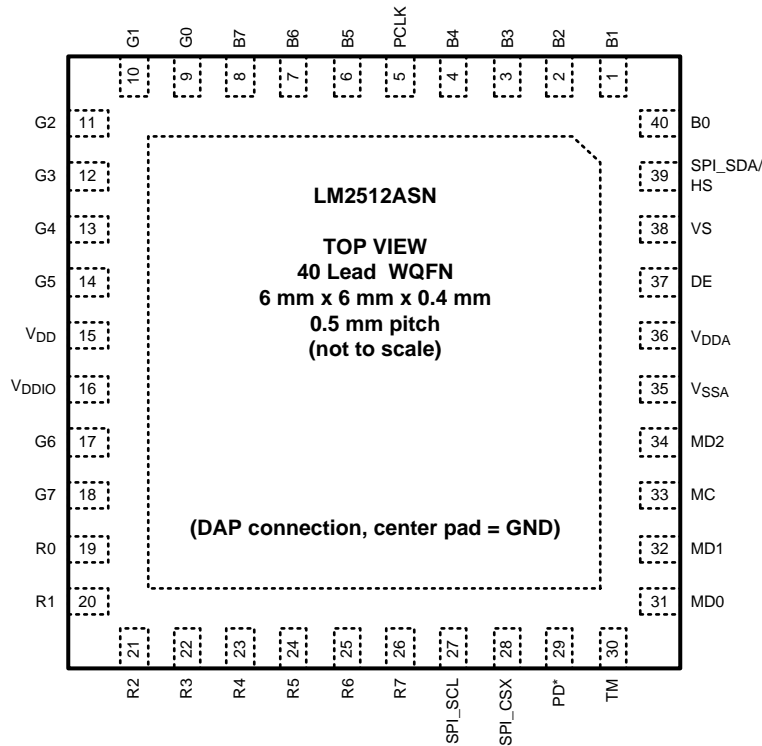

**Figure 21. TOP VIEW  
(not to scale)**

**Table 6. RGB SER Pinout**

SER	1	2	3	4	5	6	7
A	B1	SPI_SDA/HS	RES1	NC	MD2	MD1	MD0
B	B2	B0	VS	V <sub>DDA</sub>	MC	TM	PD*
C	PCLK	B3	DE	V <sub>SSA</sub>	SPI_CSX	SPI_SCL	R7
D	V <sub>SSIO</sub>	V <sub>DDIO</sub>	B4	V <sub>SSIO</sub>	V <sub>SSIO</sub>	V <sub>DDIO</sub>	R6
E	B6	B7	G5	B5	R1	R4	R5
F	G0	G1	G4	V <sub>DD</sub>	G6	R0	R3
G	G2	G3	V <sub>SS</sub>	V <sub>SSIO</sub>	V <sub>DDIO</sub>	G7	R2

**CONNECTION DIAGRAM 40 X2QFN PACKAGE**



**Figure 22. TOP VIEW (not to scale)**

---

**REVISION HISTORY**

<b>Changes from Revision A (May 2013) to Revision B</b>	<b>Page</b>
<hr/> <ul style="list-style-type: none"><li>• Changed layout of National Data Sheet to TI format .....</li></ul>	<hr/> <a href="#">20</a>

**PACKAGING INFORMATION**

Orderable Device	Status (1)	Package Type	Package Drawing	Pins	Package Qty	Eco Plan (2)	Lead/Ball Finish (6)	MSL Peak Temp (3)	Op Temp (°C)	Device Marking (4/5)	Samples
LM2512ASM/NOPB	ACTIVE	NFBGA	NZK	49	1000	Green (RoHS & no Sb/Br)	SNAGCU	Level-3-260C-168 HR	-30 to 85	2512 ASM	<a href="#">Samples</a>
LM2512ASN/NOPB	ACTIVE	X2QFN	NJM	40	250	Green (RoHS & no Sb/Br)	CU SN	Level-3-260C-168 HR	-30 to 85	2512A	<a href="#">Samples</a>

(1) The marketing status values are defined as follows:

**ACTIVE:** Product device recommended for new designs.

**LIFEBUY:** TI has announced that the device will be discontinued, and a lifetime-buy period is in effect.

**NRND:** Not recommended for new designs. Device is in production to support existing customers, but TI does not recommend using this part in a new design.

**PREVIEW:** Device has been announced but is not in production. Samples may or may not be available.

**OBSOLETE:** TI has discontinued the production of the device.

(2) Eco Plan - The planned eco-friendly classification: Pb-Free (RoHS), Pb-Free (RoHS Exempt), or Green (RoHS & no Sb/Br) - please check <http://www.ti.com/productcontent> for the latest availability information and additional product content details.

**TBD:** The Pb-Free/Green conversion plan has not been defined.

**Pb-Free (RoHS):** TI's terms "Lead-Free" or "Pb-Free" mean semiconductor products that are compatible with the current RoHS requirements for all 6 substances, including the requirement that lead not exceed 0.1% by weight in homogeneous materials. Where designed to be soldered at high temperatures, TI Pb-Free products are suitable for use in specified lead-free processes.

**Pb-Free (RoHS Exempt):** This component has a RoHS exemption for either 1) lead-based flip-chip solder bumps used between the die and package, or 2) lead-based die adhesive used between the die and leadframe. The component is otherwise considered Pb-Free (RoHS compatible) as defined above.

**Green (RoHS & no Sb/Br):** TI defines "Green" to mean Pb-Free (RoHS compatible), and free of Bromine (Br) and Antimony (Sb) based flame retardants (Br or Sb do not exceed 0.1% by weight in homogeneous material)

(3) MSL, Peak Temp. - The Moisture Sensitivity Level rating according to the JEDEC industry standard classifications, and peak solder temperature.

(4) There may be additional marking, which relates to the logo, the lot trace code information, or the environmental category on the device.

(5) Multiple Device Markings will be inside parentheses. Only one Device Marking contained in parentheses and separated by a "~" will appear on a device. If a line is indented then it is a continuation of the previous line and the two combined represent the entire Device Marking for that device.

(6) Lead/Ball Finish - Orderable Devices may have multiple material finish options. Finish options are separated by a vertical ruled line. Lead/Ball Finish values may wrap to two lines if the finish value exceeds the maximum column width.

**Important Information and Disclaimer:** The information provided on this page represents TI's knowledge and belief as of the date that it is provided. TI bases its knowledge and belief on information provided by third parties, and makes no representation or warranty as to the accuracy of such information. Efforts are underway to better integrate information from third parties. TI has taken and continues to take reasonable steps to provide representative and accurate information but may not have conducted destructive testing or chemical analysis on incoming materials and chemicals. TI and TI suppliers consider certain information to be proprietary, and thus CAS numbers and other limited information may not be available for release.

In no event shall TI's liability arising out of such information exceed the total purchase price of the TI part(s) at issue in this document sold by TI to Customer on an annual basis.

## TAPE AND REEL INFORMATION



### QUADRANT ASSIGNMENTS FOR PIN 1 ORIENTATION IN TAPE



\*All dimensions are nominal

Device	Package Type	Package Drawing	Pins	SPQ	Reel Diameter (mm)	Reel Width W1 (mm)	A0 (mm)	B0 (mm)	K0 (mm)	P1 (mm)	W (mm)	Pin1 Quadrant
LM2512ASM/NOPB	NFBGA	NZK	49	1000	178.0	12.4	4.3	4.3	1.5	8.0	12.0	Q1
LM2512ASN/NOPB	X2QFN	NJM	40	250	178.0	16.4	6.3	6.3	1.5	12.0	16.0	Q1

**TAPE AND REEL BOX DIMENSIONS**



\*All dimensions are nominal

Device	Package Type	Package Drawing	Pins	SPQ	Length (mm)	Width (mm)	Height (mm)
LM2512ASM/NOPB	NFBGA	NZK	49	1000	210.0	185.0	35.0
LM2512ASN/NOPB	X2QFN	NJM	40	250	210.0	185.0	35.0

NZK0049A

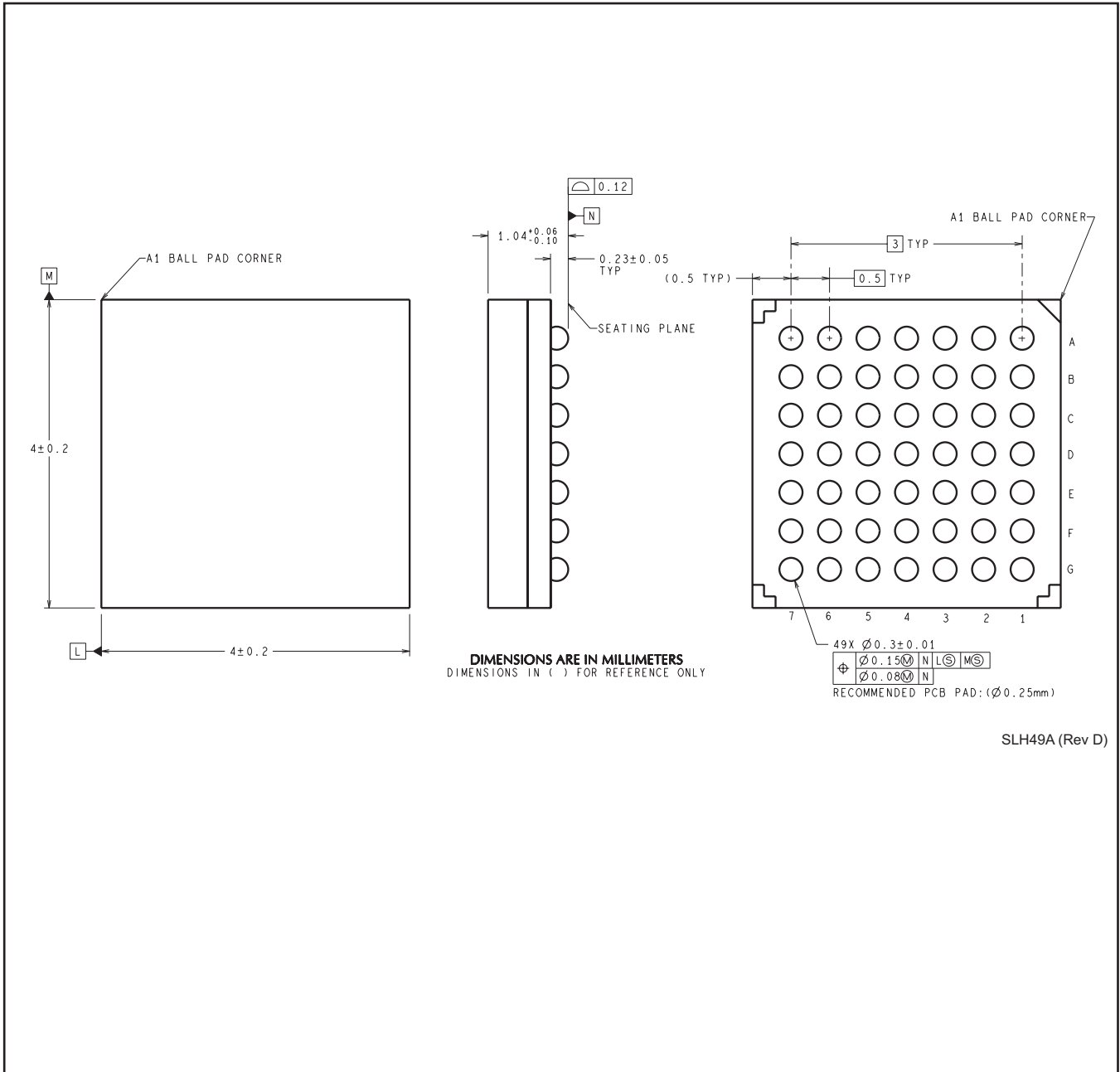

SLH49A (Rev D)

NJM0040A

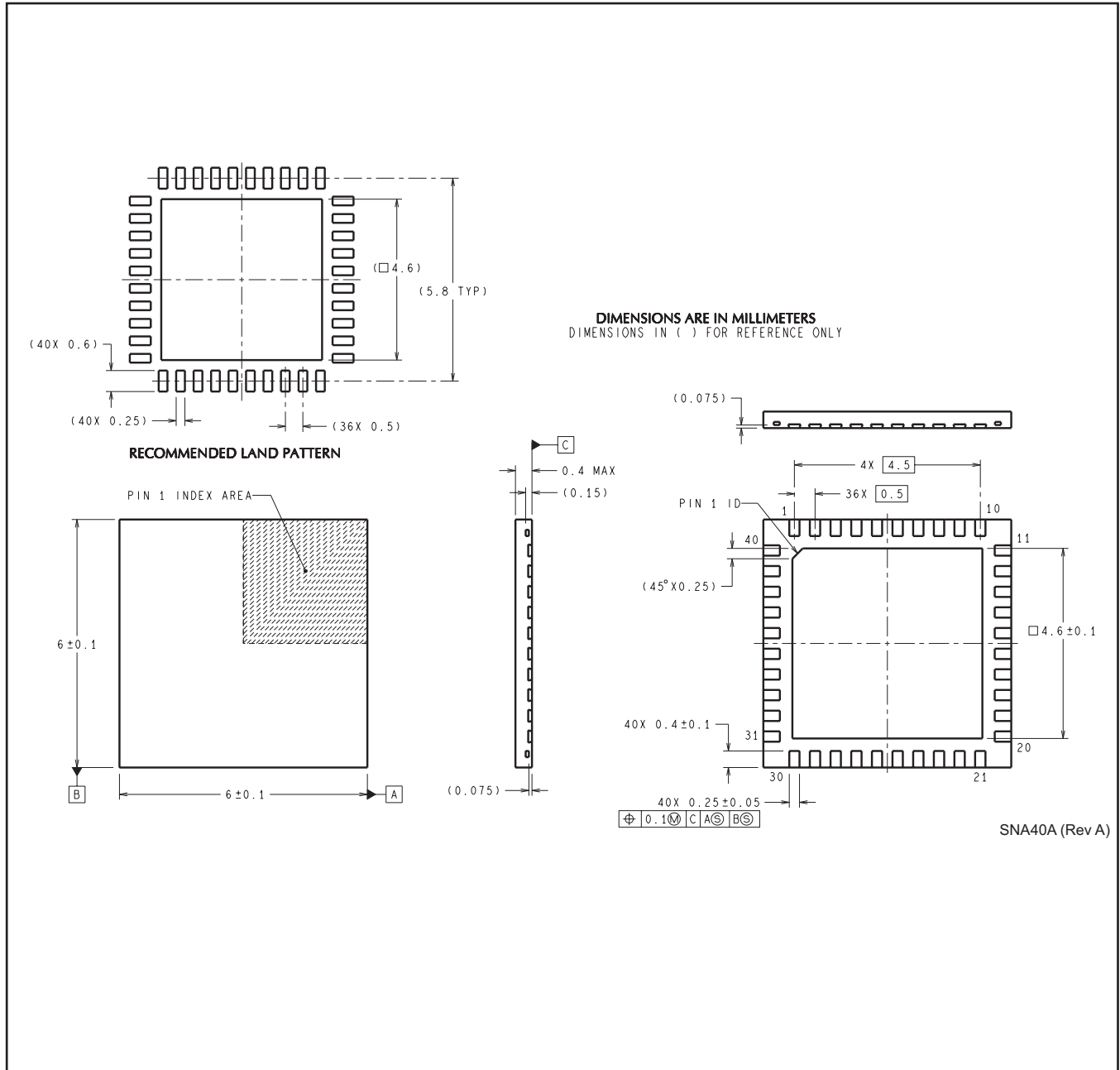

## IMPORTANT NOTICE

Texas Instruments Incorporated and its subsidiaries (TI) reserve the right to make corrections, enhancements, improvements and other changes to its semiconductor products and services per JESD46, latest issue, and to discontinue any product or service per JESD48, latest issue. Buyers should obtain the latest relevant information before placing orders and should verify that such information is current and complete. All semiconductor products (also referred to herein as "components") are sold subject to TI's terms and conditions of sale supplied at the time of order acknowledgment.

TI warrants performance of its components to the specifications applicable at the time of sale, in accordance with the warranty in TI's terms and conditions of sale of semiconductor products. Testing and other quality control techniques are used to the extent TI deems necessary to support this warranty. Except where mandated by applicable law, testing of all parameters of each component is not necessarily performed.

TI assumes no liability for applications assistance or the design of Buyers' products. Buyers are responsible for their products and applications using TI components. To minimize the risks associated with Buyers' products and applications, Buyers should provide adequate design and operating safeguards.

TI does not warrant or represent that any license, either express or implied, is granted under any patent right, copyright, mask work right, or other intellectual property right relating to any combination, machine, or process in which TI components or services are used. Information published by TI regarding third-party products or services does not constitute a license to use such products or services or a warranty or endorsement thereof. Use of such information may require a license from a third party under the patents or other intellectual property of the third party, or a license from TI under the patents or other intellectual property of TI.

Reproduction of significant portions of TI information in TI data books or data sheets is permissible only if reproduction is without alteration and is accompanied by all associated warranties, conditions, limitations, and notices. TI is not responsible or liable for such altered documentation. Information of third parties may be subject to additional restrictions.

Resale of TI components or services with statements different from or beyond the parameters stated by TI for that component or service voids all express and any implied warranties for the associated TI component or service and is an unfair and deceptive business practice. TI is not responsible or liable for any such statements.

Buyer acknowledges and agrees that it is solely responsible for compliance with all legal, regulatory and safety-related requirements concerning its products, and any use of TI components in its applications, notwithstanding any applications-related information or support that may be provided by TI. Buyer represents and agrees that it has all the necessary expertise to create and implement safeguards which anticipate dangerous consequences of failures, monitor failures and their consequences, lessen the likelihood of failures that might cause harm and take appropriate remedial actions. Buyer will fully indemnify TI and its representatives against any damages arising out of the use of any TI components in safety-critical applications.

In some cases, TI components may be promoted specifically to facilitate safety-related applications. With such components, TI's goal is to help enable customers to design and create their own end-product solutions that meet applicable functional safety standards and requirements. Nonetheless, such components are subject to these terms.

No TI components are authorized for use in FDA Class III (or similar life-critical medical equipment) unless authorized officers of the parties have executed a special agreement specifically governing such use.

Only those TI components which TI has specifically designated as military grade or "enhanced plastic" are designed and intended for use in military/aerospace applications or environments. Buyer acknowledges and agrees that any military or aerospace use of TI components which have **not** been so designated is solely at the Buyer's risk, and that Buyer is solely responsible for compliance with all legal and regulatory requirements in connection with such use.

TI has specifically designated certain components as meeting ISO/TS16949 requirements, mainly for automotive use. In any case of use of non-designated products, TI will not be responsible for any failure to meet ISO/TS16949.

### Products

Audio	<a href="http://www.ti.com/audio">www.ti.com/audio</a>
Amplifiers	<a href="http://amplifier.ti.com">amplifier.ti.com</a>
Data Converters	<a href="http://dataconverter.ti.com">dataconverter.ti.com</a>
DLP® Products	<a href="http://www.dlp.com">www.dlp.com</a>
DSP	<a href="http://dsp.ti.com">dsp.ti.com</a>
Clocks and Timers	<a href="http://www.ti.com/clocks">www.ti.com/clocks</a>
Interface	<a href="http://interface.ti.com">interface.ti.com</a>
Logic	<a href="http://logic.ti.com">logic.ti.com</a>
Power Mgmt	<a href="http://power.ti.com">power.ti.com</a>
Microcontrollers	<a href="http://microcontroller.ti.com">microcontroller.ti.com</a>
RFID	<a href="http://www.ti-rfid.com">www.ti-rfid.com</a>
OMAP Applications Processors	<a href="http://www.ti.com/omap">www.ti.com/omap</a>
Wireless Connectivity	<a href="http://www.ti.com/wirelessconnectivity">www.ti.com/wirelessconnectivity</a>

### Applications

Automotive and Transportation	<a href="http://www.ti.com/automotive">www.ti.com/automotive</a>
Communications and Telecom	<a href="http://www.ti.com/communications">www.ti.com/communications</a>
Computers and Peripherals	<a href="http://www.ti.com/computers">www.ti.com/computers</a>
Consumer Electronics	<a href="http://www.ti.com/consumer-apps">www.ti.com/consumer-apps</a>
Energy and Lighting	<a href="http://www.ti.com/energy">www.ti.com/energy</a>
Industrial	<a href="http://www.ti.com/industrial">www.ti.com/industrial</a>
Medical	<a href="http://www.ti.com/medical">www.ti.com/medical</a>
Security	<a href="http://www.ti.com/security">www.ti.com/security</a>
Space, Avionics and Defense	<a href="http://www.ti.com/space-avionics-defense">www.ti.com/space-avionics-defense</a>
Video and Imaging	<a href="http://www.ti.com/video">www.ti.com/video</a>

### TI E2E Community

[e2e.ti.com](http://e2e.ti.com)

## Looking for pricing, stock, or lifecycle information?

Click below to explore more details on WIN SOURCE:

 [View LM2512ASN](#)X on WIN SOURCE

 [Texas Instruments](#) Information

## Optimize Your Supply Chain with WIN SOURCE Solutions

-  Global Sourcing Solution
-  Obsolete Management
-  Cost Control Management
-  Shortage Management
-  Alternative Solution
-  Excess Inventory Management