



# THE DATASHEET OF LM224QT



## Low-power quad operational amplifiers

Datasheet - production data

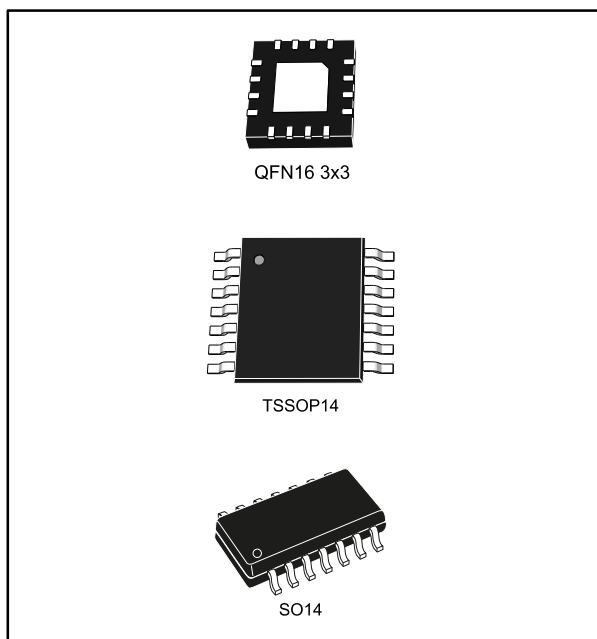

### Related products

- See [TSB572](#) and [TSB611](#), 36 V newer technology devices, which have enhanced accuracy and ESD rating, reduced power consumption, and automotive grade qualification
- See LM2902 and LM2902W for automotive grade applications

### Description

These circuits consist of four independent, high gain operational amplifiers with frequency compensation implemented internally. They operate from a single power supply over a wide range of voltages.

Operation from split power supplies is also possible and the low-power supply current drain is independent of the magnitude of the power supply voltage.

### Features

- Wide gain bandwidth: 1.3 MHz
- Input common mode voltage range includes ground
- Large voltage gain: 100 dB
- Very low supply current/amplifier: 375  $\mu$ A
- Low input bias current: 20 nA
- Low input voltage: 3 mV max
- Low input offset current: 2 nA
- Wide power supply range:
  - Single supply: 3 V to 30 V
  - Dual supplies:  $\pm 1.5$  V to  $\pm 15$  V

Table 1: Device summary

Product reference	Part numbers
LM124 <sup>(1)</sup>	LM124
LM224x	LM224, LM224A <sup>(2)</sup> , LM224W <sup>(3)</sup>
LM324x	LM324, LM324A, LM324W

#### Notes:

<sup>(1)</sup>Prefixes LM1, LM2, and LM3 refer to temperature range.

<sup>(2)</sup>Suffix A refers to enhanced V<sub>io</sub> performance

<sup>(3)</sup>Suffix W refers to enhanced ESD ratings

**Contents**

**1 Pin connections and schematic diagram ..... 3**

**2 Absolute maximum ratings and operating conditions ..... 5**

**3 Electrical characteristics ..... 7**

**4 Electrical characteristic curves ..... 9**

**5 Typical single-supply applications ..... 12**

**6 Package information ..... 14**

    6.1 QFN16 3x3 package information..... 15

    6.2 TSSOP14 package information..... 17

    6.3 SO14 package information..... 18

**7 Ordering information..... 19**

**8 Revision history ..... 20**

# 1 Pin connections and schematic diagram

Figure 1: Pin connections (top view)

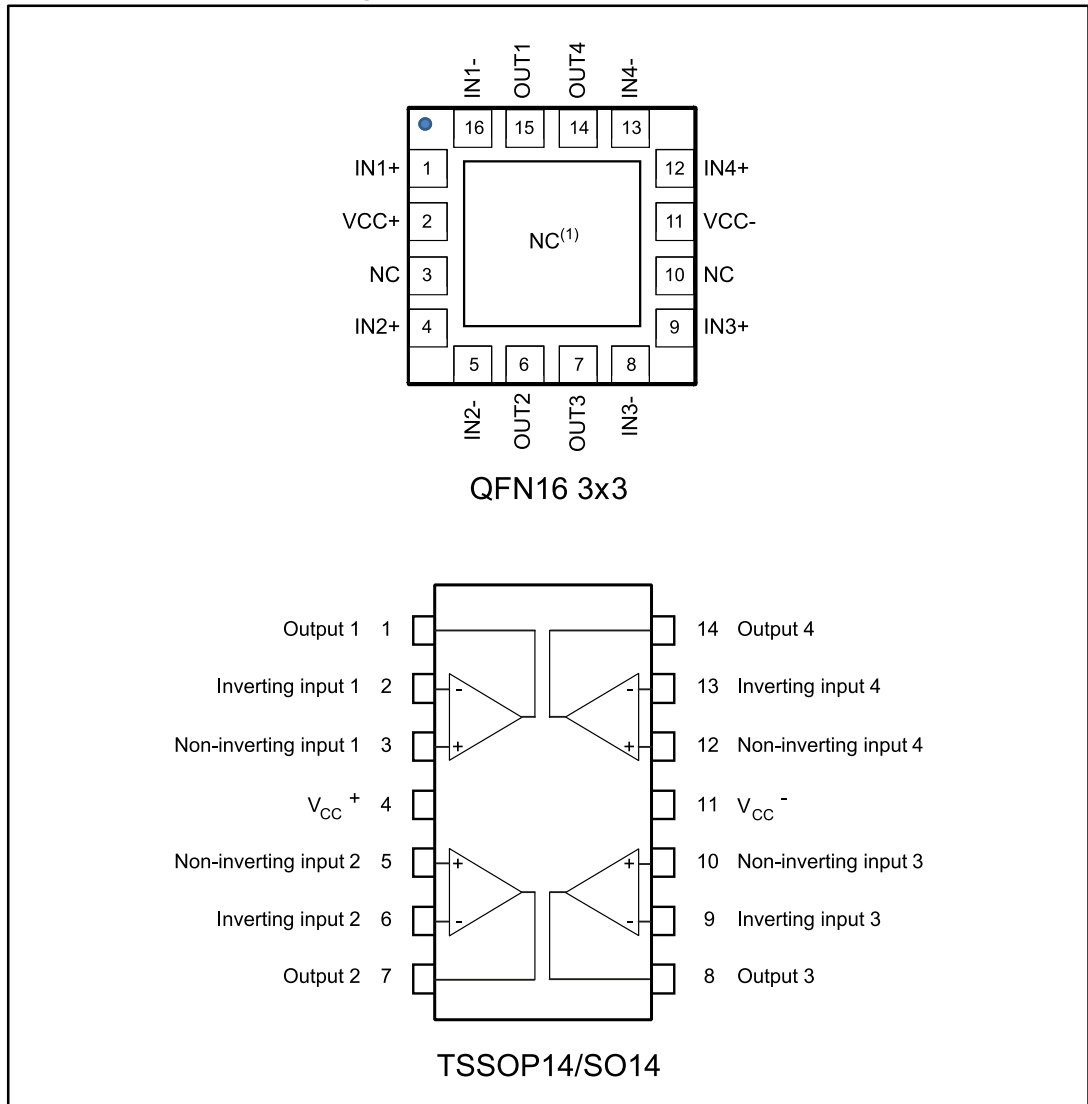

1. The exposed pads of the QFN16 3x3 can be connected to VCC- or left floating

Figure 2: Schematic diagram (LM224A, LM324A, LM324W, one channel)

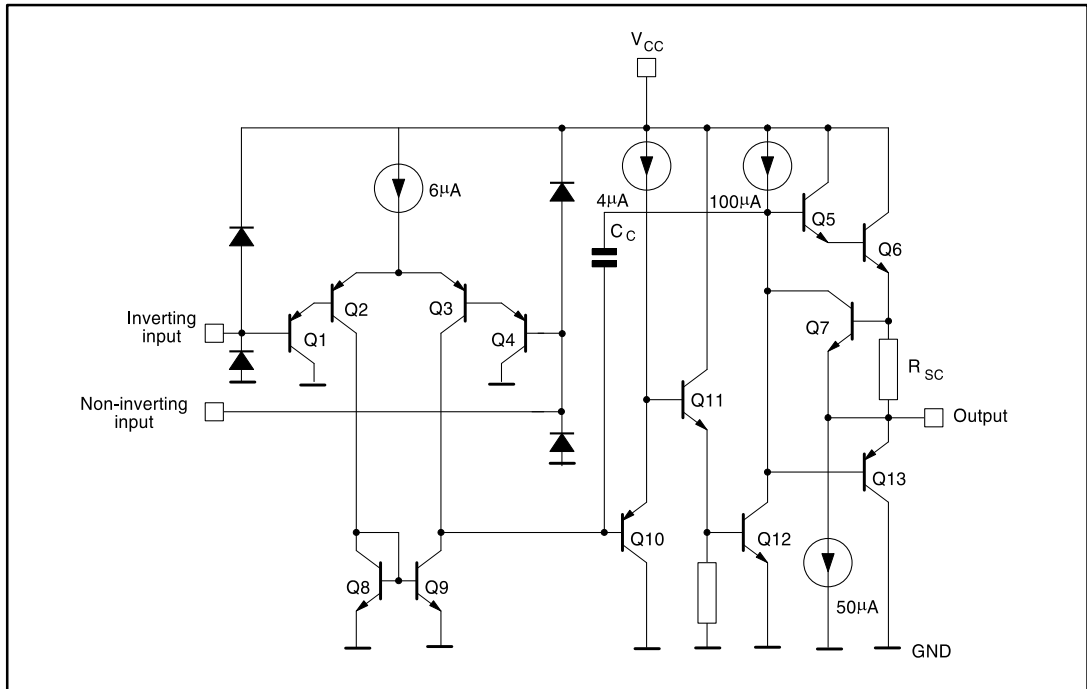
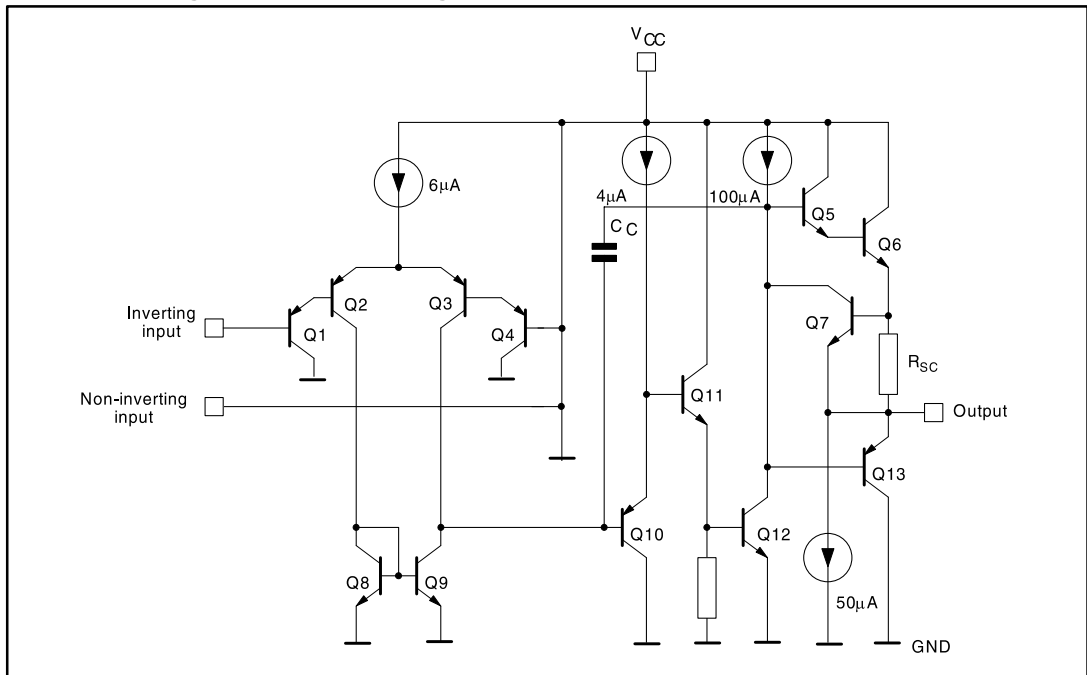

Figure 3: Schematic diagram (LM124, LM224, LM324, one channel)



## 2 Absolute maximum ratings and operating conditions

Table 2: Absolute maximum ratings

Symbol	Parameter	Value	Unit	
V <sub>CC</sub>	Supply voltage	±16 or 32	V	
V <sub>i</sub>	Input voltage	-0.3 to V <sub>CC</sub> + 0.3		
V <sub>id</sub>	Differential input voltage <sup>(1)</sup>	32		
P <sub>tot</sub>	Power dissipation: D suffix	400	mW	
	Output short-circuit duration <sup>(2)</sup>	Infinite		
I <sub>in</sub>	Input current <sup>(3)</sup>	50	mA	
T <sub>stg</sub>	Storage temperature range	-65 to 150	°C	
T <sub>j</sub>	Maximum junction temperature	150		
R <sub>thja</sub>	Thermal resistance junction to ambient <sup>(4)</sup>	QFN16 3x3	45	°C/W
		TSSOP14	100	
		SO14	103	
R <sub>thjc</sub>	Thermal resistance junction to case	QFN16 3x3	14	
		TSSOP14	32	
		SO14	31	
ESD	HBM: human body model <sup>(5)</sup>	LM224A, LM324A	800	V
		LM124W, LM324W	700	
		LM124, LM224, LM324	250	
	MM: machine model <sup>(6)</sup>	100		
	CDM: charged device model	1500		

### Notes:

<sup>(1)</sup>Neither of the input voltages must exceed the magnitude of (V<sub>CC</sub><sup>+</sup>) or (V<sub>CC</sub><sup>-</sup>).

<sup>(2)</sup>Short-circuits from the output to V<sub>CC</sub> can cause excessive heating if V<sub>CC</sub> > 15 V. The maximum output current is approximately 40 mA independent of the magnitude of V<sub>CC</sub>. Destructive dissipation can result from simultaneous short-circuits on all amplifiers.

<sup>(3)</sup>This input current only exists when the voltage at any of the input leads is driven negative. It is due to the collector-base junction of the input PNP transistor becoming forward biased and thereby acting as an input diode clamp. In addition to this diode action, there is also an NPN parasitic action on the IC chip. This transistor action can cause the output voltages of the op amps to go to the V<sub>CC</sub> voltage level (or to ground for a large overdrive) for the time during which an input is driven negative. This is not destructive and normal output starts up again for input voltages higher than -0.3 V.

<sup>(4)</sup>Short-circuits can cause excessive heating. Destructive dissipation can result from simultaneous short-circuits on all amplifiers. These are typical values given for a single layer board (except for TSSOP which is a two-layer board).

<sup>(5)</sup>Human body model: 100 pF discharged through a 1.5 kΩ resistor between two pins of the device, done for all couples of pin combinations with other pins floating.

<sup>(6)</sup>Machine model: a 200 pF cap is charged to the specified voltage, then discharged directly between two pins of the device with no external series resistor (internal resistor < 5 Ω), done for all couples of pin combinations with other pins floating.

Table 3: Operating conditions

Symbol	Parameter	Value	Unit
V <sub>CC</sub>	Supply voltage	Single supply	3 to 30
		Dual supply	±1.5 to ±15
V <sub>ICM</sub>	Common-mode input voltage range	(V <sub>CC</sub> ) - 0.1 to (V <sub>CC</sub> <sup>+</sup> ) - 1	V
T <sub>Oper</sub>	Operating temperature range	LM124	-55 to 125
		LM224	-40 to 105
		LM324	0 to 70

### 3 Electrical characteristics

Table 4:  $V_{CC+} = 5\text{ V}$ ,  $V_{CC-} = \text{Ground}$ ,  $V_o = 1.4\text{ V}$ ,  $T_{amb} = 25\text{ }^\circ\text{C}$  (unless otherwise specified)

Symbol	Parameter	Min.	Typ.	Max.	Unit	
$V_{io}$ LM224A, LM224W, LM324A, LM324W		$T_{amb} = 25\text{ }^\circ\text{C}$		2	3	
		$T_{min} \leq T_{amb} \leq T_{max}$			5	
$V_{io}$ LM124, LM224, LM324	Input offset voltage <sup>(1)</sup>	$T_{amb} = 25\text{ }^\circ\text{C}$	LM124	2	5	mV
			LM224			
			LM324	2	7	
		$T_{min} \leq T_{amb} \leq T_{max}$	LM124		7	
			LM224			
			LM324		9	
$i_{io}$	Input offset current	$T_{amb} = 25\text{ }^\circ\text{C}$		2	20	nA
		$T_{min} \leq T_{amb} \leq T_{max}$			40	
$i_{ib}$	Input bias current <sup>(2)</sup>	$T_{amb} = 25\text{ }^\circ\text{C}$		20	100	nA
		$T_{min} \leq T_{amb} \leq T_{max}$			200	
$A_{vd}$	Large signal voltage gain, $V_{CC+} = 15\text{ V}$ , $R_L = 2\text{ k}\Omega$ , $V_o = 1.4\text{ V}$ to $11.4\text{ V}$	$T_{amb} = 25\text{ }^\circ\text{C}$	50	100		V/mV
		$T_{min} \leq T_{amb} \leq T_{max}$	25			
SVR	Supply voltage rejection ratio, $R_s \leq 10\text{ k}\Omega$ , $V_{CC+} = 5\text{ V}$ to $30\text{ V}$	$T_{amb} = 25\text{ }^\circ\text{C}$	65	110		dB
		$T_{min} \leq T_{amb} \leq T_{max}$	65			
$I_{CC}$	Supply current, all amps, no load	$T_{amb} = 25\text{ }^\circ\text{C}$ , $V_{CC} = 5\text{ V}$		0.7	1.2	mA
		$T_{amb} = 25\text{ }^\circ\text{C}$ , $V_{CC} = 30\text{ V}$		1.5	3	
		$T_{min} \leq T_{amb} \leq T_{max}$ , $V_{CC} = 5\text{ V}$		0.8	1.2	
		$T_{min} \leq T_{amb} \leq T_{max}$ , $V_{CC} = 30\text{ V}$		1.5	3	
$V_{icm}$	Input common mode voltage range <sup>(3)</sup>	$V_{CC} = 30\text{ V}$ , $T_{amb} = 25\text{ }^\circ\text{C}$	0		28.5	V
		$V_{CC} = 30\text{ V}$ , $T_{min} \leq T_{amb} \leq T_{max}$	0		28	
CMR	Common mode rejection ratio, $R_s \leq 10\text{ k}\Omega$	$T_{amb} = 25\text{ }^\circ\text{C}$	70	80		dB
		$T_{min} \leq T_{amb} \leq T_{max}$	60			
$I_{source}$	Output current source, $V_{id} = 1\text{ V}$	$V_{CC} = 15\text{ V}$ , $V_o = 2\text{ V}$	20	40	70	mA
$I_{sink}$	Output sink current, $V_{id} = -1\text{ V}$	$V_{CC} = 15\text{ V}$ , $V_o = 2\text{ V}$	10	20		
$V_{OH}$	High level output voltage, $V_{CC} = 30\text{ V}$ , $R_L = 2\text{ k}\Omega$	$T_{amb} = 25\text{ }^\circ\text{C}$	26	27		V
		$T_{min} \leq T_{amb} \leq T_{max}$	26			
	High level output voltage, $V_{CC} = 30\text{ V}$ , $R_L = 10\text{ k}\Omega$	$T_{amb} = 25\text{ }^\circ\text{C}$	27	28		
		$T_{min} \leq T_{amb} \leq T_{max}$	27			
	High level output voltage, $V_{CC} = 5\text{ V}$ , $R_L = 2\text{ k}\Omega$	$T_{amb} = 25\text{ }^\circ\text{C}$	3.5			
		$T_{min} \leq T_{amb} \leq T_{max}$	3			

**Electrical characteristics**

**LM124, LM224x, LM324x**

Symbol	Parameter	Min.	Typ.	Max.	Unit
V <sub>OL</sub>	Low level output voltage, R <sub>L</sub> = 10kΩ	T <sub>amb</sub> = 25 °C	5	20	mV
		T <sub>min</sub> ≤ T <sub>amb</sub> ≤ T <sub>max</sub>		20	
SR	Slew rate		0.4		V/μs
GBP	Gain bandwidth product		1.3		MHz
THD	Total harmonic distortion		0.015		%
e <sub>n</sub>	Equivalent input noise voltage		40		nV/√Hz
DV <sub>io</sub>	Input offset voltage drift		7	30	μV/°C
DI <sub>io</sub>	Input offset current drift		10	200	pA/°C
V <sub>o1</sub> /V <sub>o2</sub>	Channel separation <sup>(4)</sup>		120		kHz

**Notes:**

<sup>(1)</sup>V<sub>o</sub> = 1.4 V, R<sub>s</sub> = 0 Ω, 5 V < V<sub>CC</sub><sup>+</sup> < 30 V, 0 < V<sub>ic</sub> < V<sub>CC</sub><sup>+</sup> - 1.5 V

<sup>(2)</sup>The direction of the input current is out of the IC. This current is essentially constant, independent of the state of the output so there is no load change on the input lines.

<sup>(3)</sup>The input common-mode voltage of either input signal voltage should not be allowed to go negative by more than 0.3 V. The upper end of the common-mode voltage range is (V<sub>CC</sub><sup>+</sup>) - 1.5 V, but either or both inputs can go to 32 V without damage.

<sup>(4)</sup>Due to the proximity of external components, ensure that there is no coupling originating from stray capacitance between these external parts. Typically, this can be detected at higher frequencies because this type of capacitance increases.



## 4 Electrical characteristic curves

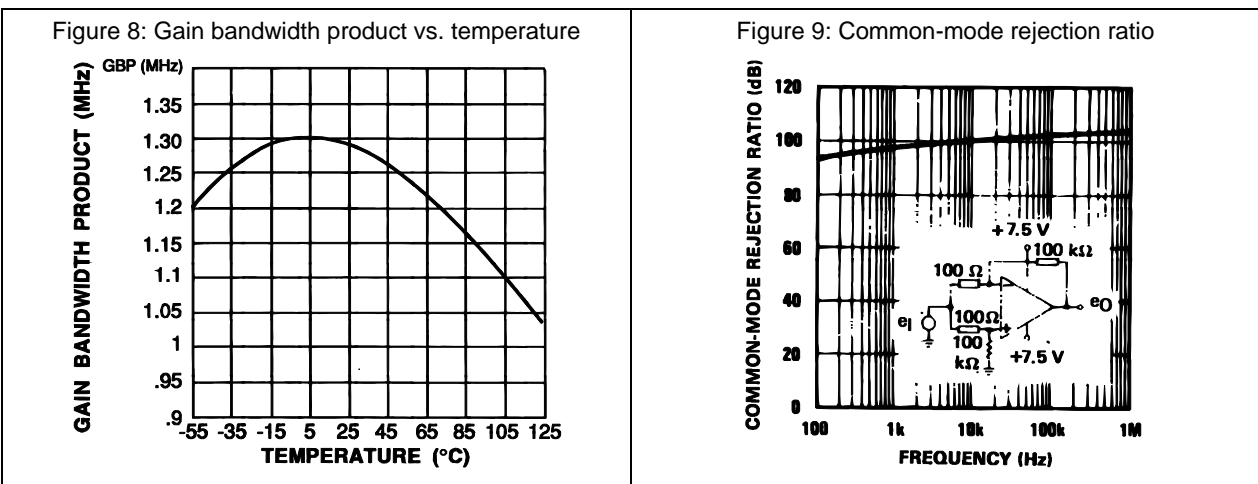
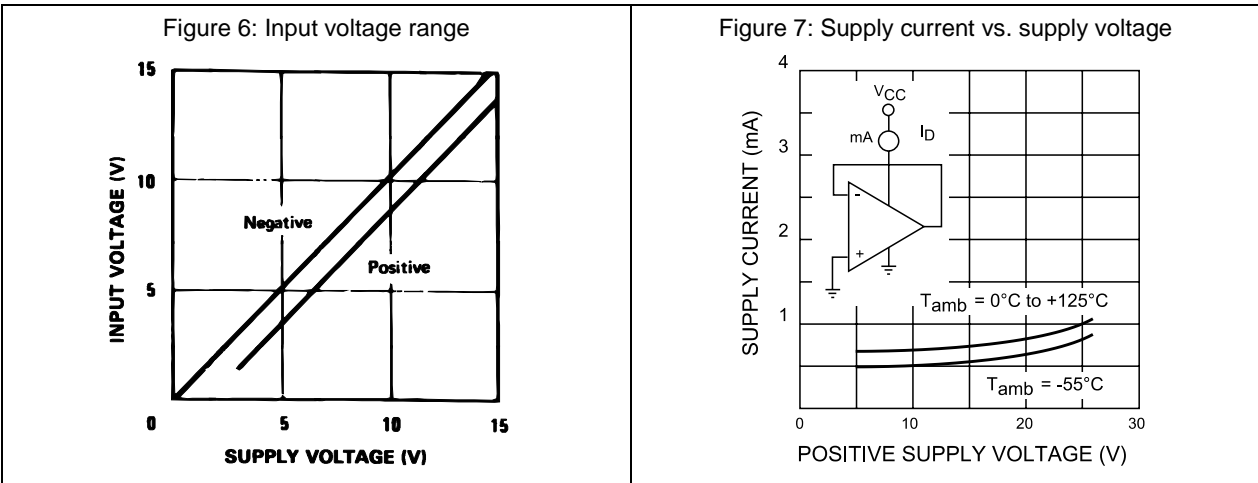
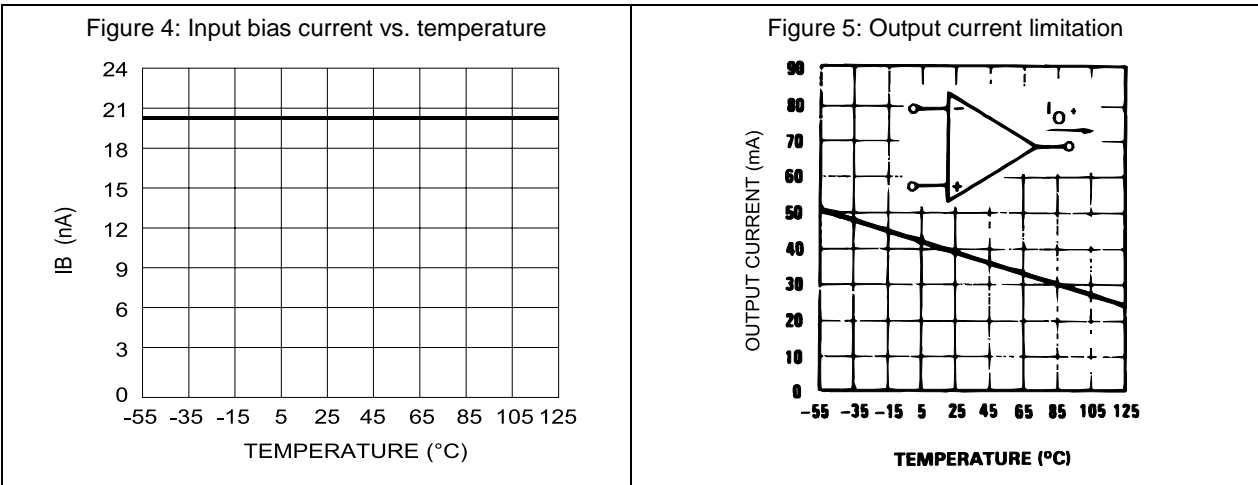

Figure 10: Open loop frequency response

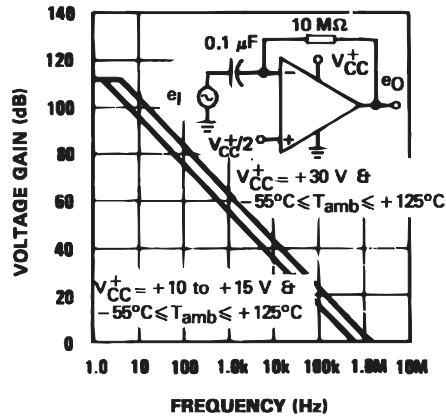

Figure 11: Large signal frequency response

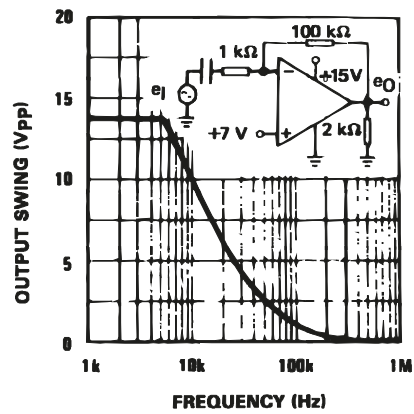

Figure 12: Voltage follower pulse response

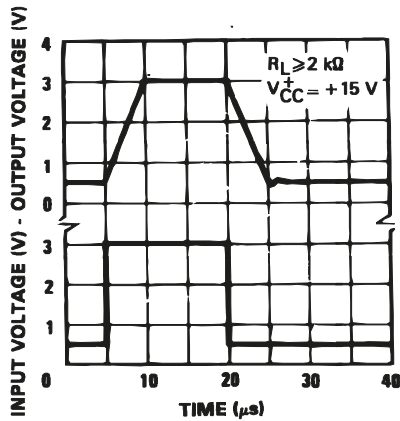

Figure 13: Output characteristics (current sinking)

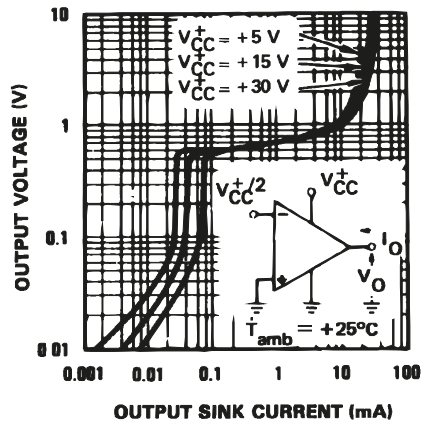

Figure 14: Voltage follower pulse response (small signal)

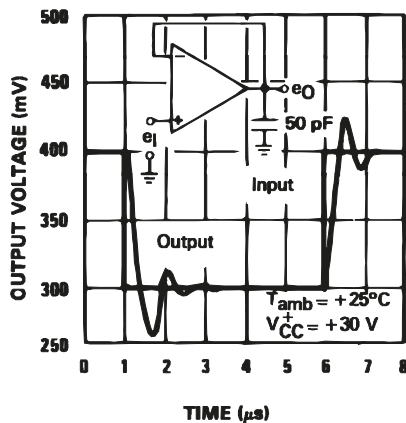

Figure 15: Output characteristics (current sourcing)

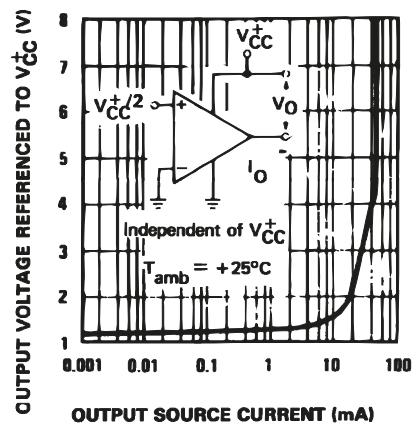

Figure 16: Input current vs. supply voltage

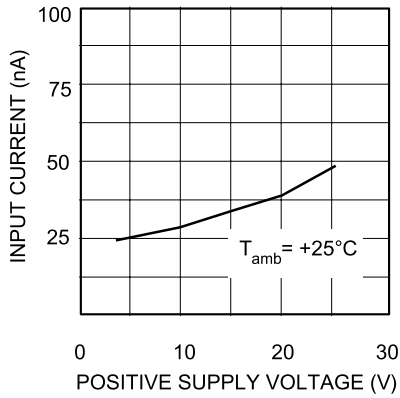

Figure 17: Large signal voltage gain vs. temperature

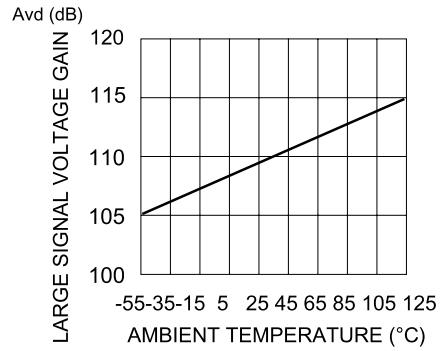

Figure 18: Power supply and common mode rejection ratio vs. temperature

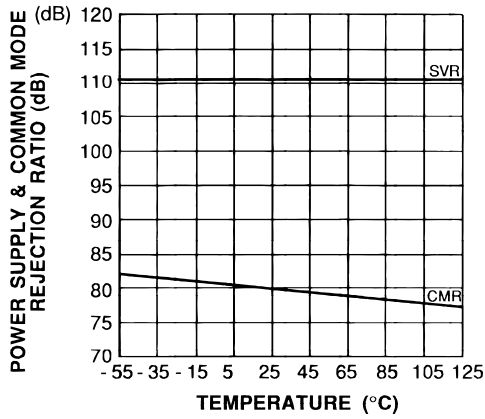
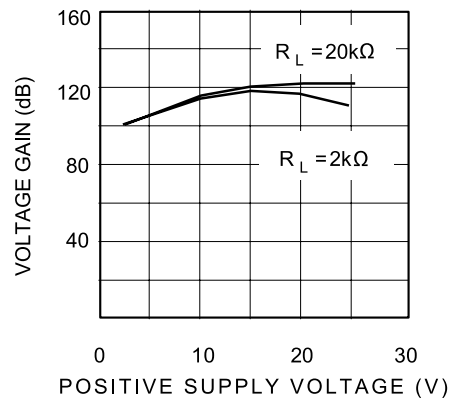
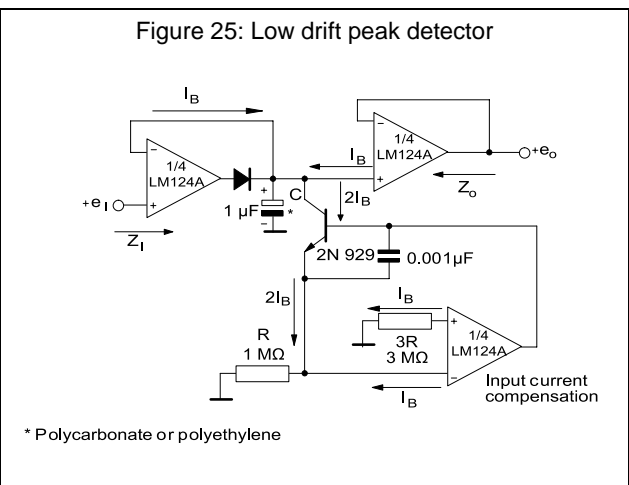
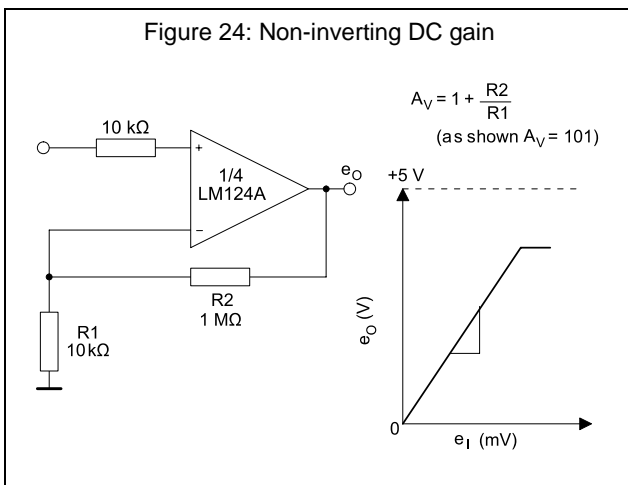
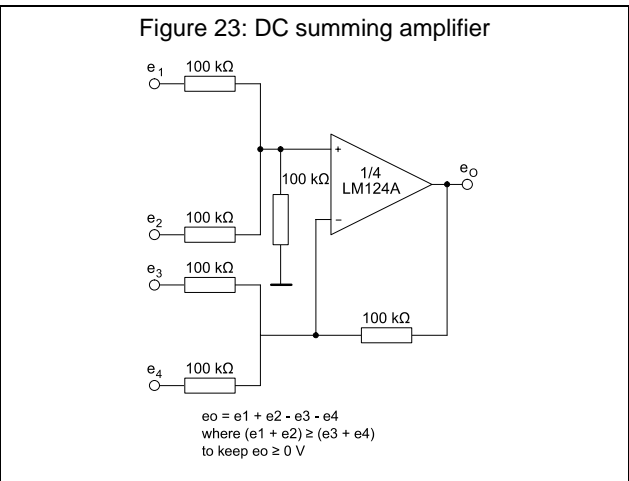
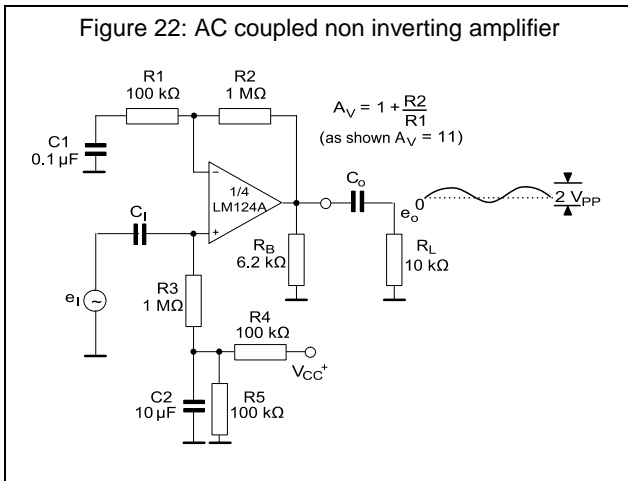
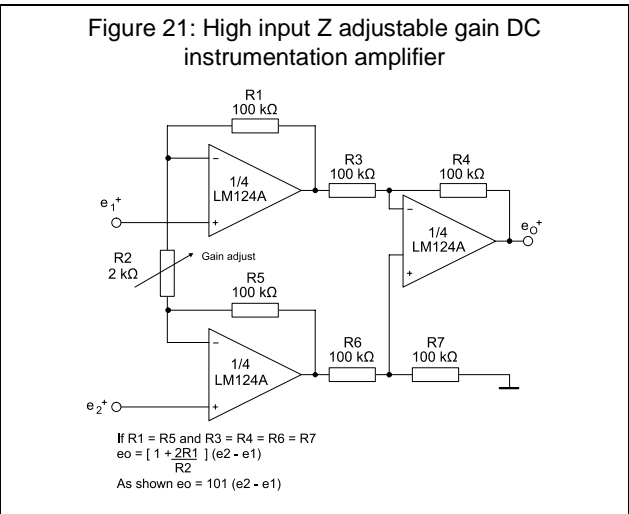
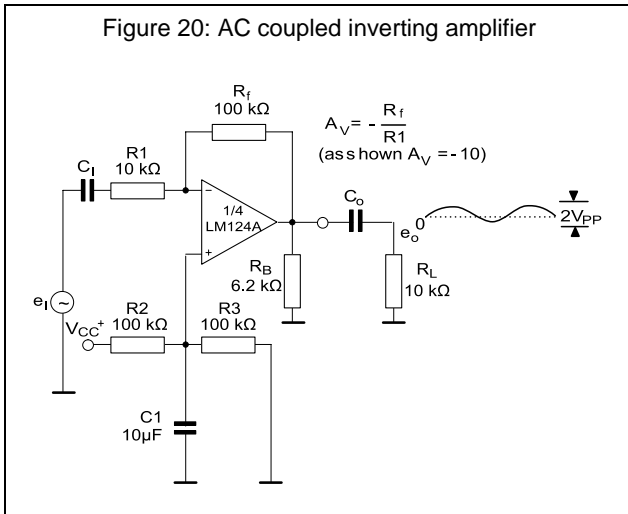
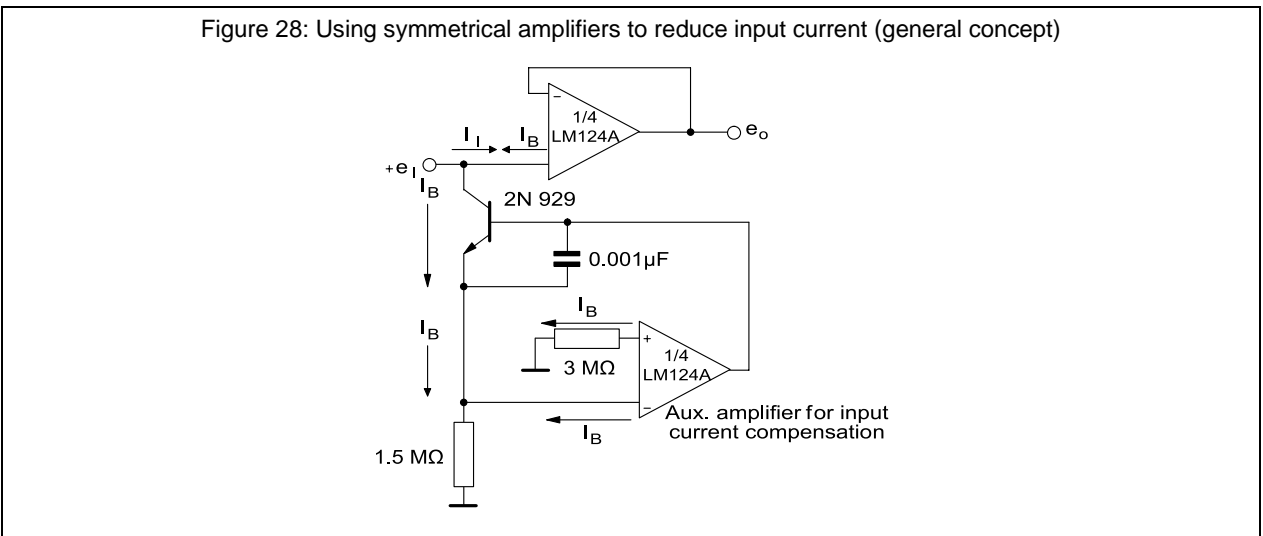
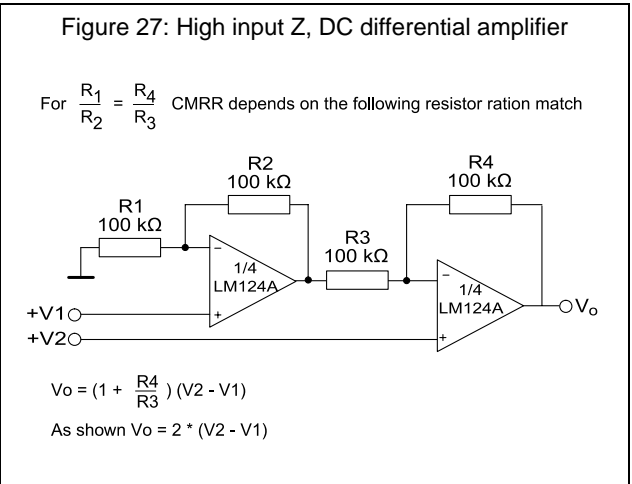
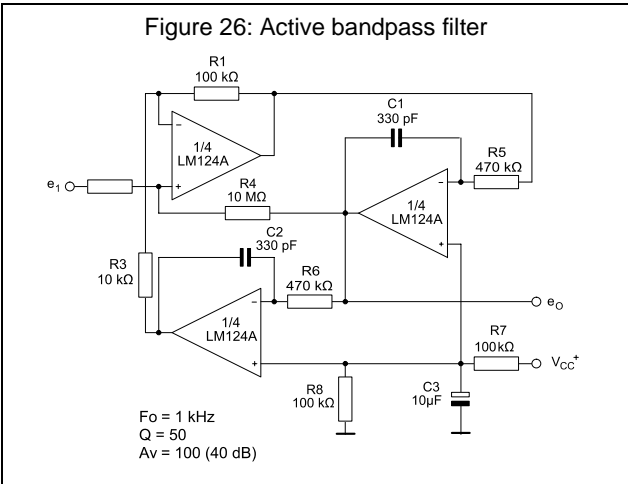

Figure 19: Voltage gain vs. supply voltage



## 5 Typical single-supply applications





## 6 Package information

In order to meet environmental requirements, ST offers these devices in different grades of ECOPACK® packages, depending on their level of environmental compliance. ECOPACK® specifications, grade definitions and product status are available at: [www.st.com](http://www.st.com). ECOPACK® is an ST trademark.

### 6.1 QFN16 3x3 package information

Figure 29: QFN16 3x3 package outline

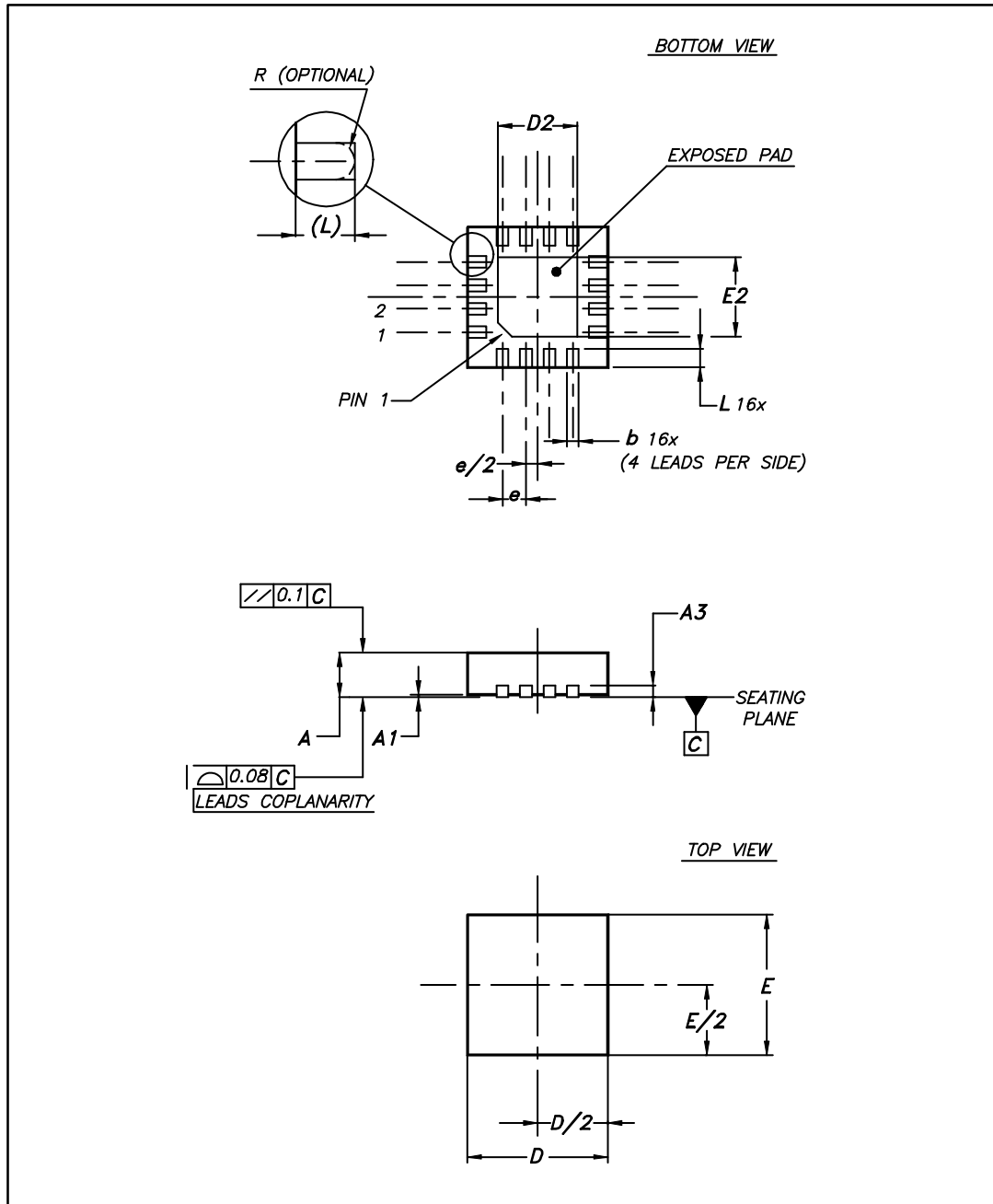



## 6.2 TSSOP14 package information

Figure 31: TSSOP14 package outline

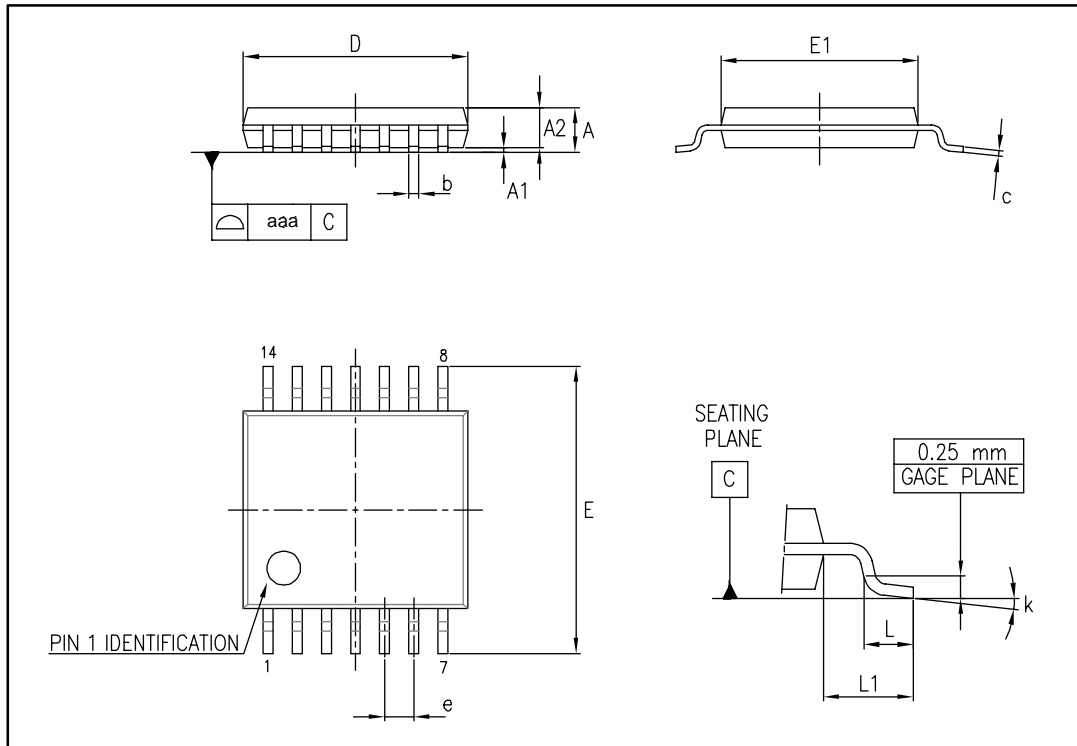

Table 6: TSSOP14 mechanical data

Ref.	Dimensions					
	Millimeters			Inches		
	Min.	Typ.	Max.	Min.	Typ.	Max.
A			1.20			0.047
A1	0.05		0.15	0.002	0.004	0.006
A2	0.80	1.00	1.05	0.031	0.039	0.041
b	0.19		0.30	0.007		0.012
c	0.09		0.20	0.004		0.0089
D	4.90	5.00	5.10	0.193	0.197	0.201
E	6.20	6.40	6.60	0.244	0.252	0.260
E1	4.30	4.40	4.50	0.169	0.173	0.176
e		0.65			0.0256	
L	0.45	0.60	0.75	0.018	0.024	0.030
L1		1.00			0.039	
k	0°		8°	0°		8°
aaa			0.10			0.004

### 6.3 SO14 package information

Figure 32: SO14 package outline

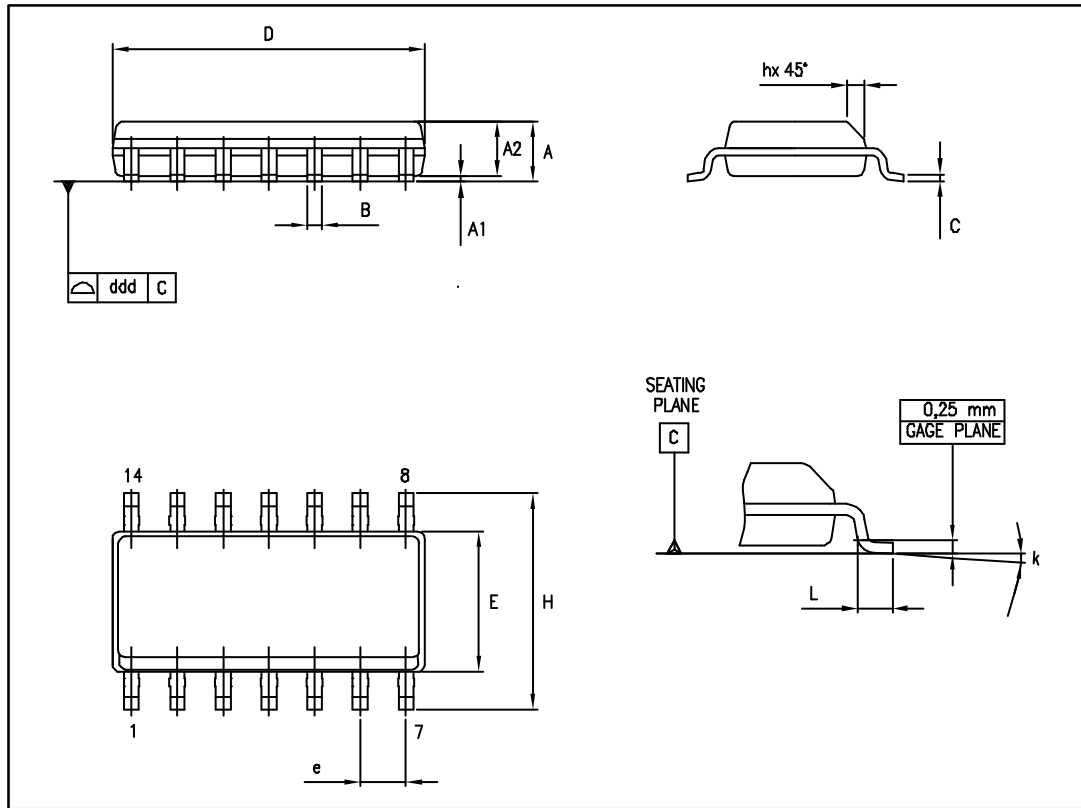

Table 7: SO14 mechanical data

Ref.	Dimensions					
	Millimeters			Inches		
	Min.	Typ.	Max.	Min.	Typ.	Max.
A	1.35		1.75	0.05		0.068
A1	0.10		0.25	0.004		0.009
A2	1.10		1.65	0.04		0.06
B	0.33		0.51	0.01		0.02
C	0.19		0.25	0.007		0.009
D	8.55		8.75	0.33		0.34
E	3.80		4.0	0.15		0.15
e		1.27			0.05	
H	5.80		6.20	0.22		0.24
h	0.25		0.50	0.009		0.02
L	0.40		1.27	0.015		0.05
k	8° (max)					
ddd			0.10			0.004

## 7 Ordering information

Table 8: Order codes

Order code	Temperature range	ESD (HBM, CDM)	V <sub>io</sub> max @ 25 °C	Package	Marking
LM124DT	-55 °C to 125 °C	250 V, 1.5 kV	5 mV	SO14	124
LM224ADT	-40 °C to 105 °C	800 V, 1.5 kV	3 mV		TSSOP14
LM224APT				250 V, 1.5 kV	5 mV
LM224DT		TSSOP14			
LM224PT		QFN16 3x3	K425		
LM224QDT		700 V, 1.5 kV	3 mV	SO14	224W
LM224WDT		800 V, 1.5 kV			TSSOP14
LM324ADT			0 °C to 70 °C	700 V, 1.5 kV	SO14
LM324APT	TSSOP14				
LM324AWDT	SO14	324W			
LM324AWPT				TSSOP14	
LM324WDT	250 V, 1.5 kV	5 mV		SO14	324
LM324WPT				TSSOP14	
LM324QDT				QFN16 3x3	K427

## 8 Revision history

**Table 9: Document revision history**

Date	Revision	Changes
1-Mar-2001	1	First release
1-Feb-2005	2	Added explanation of $V_{id}$ and $V_i$ limits in Table 2 on page 4. Updated macromodel.
1-Jun-2005	3	ESD protection inserted in Table 2 on page 4.
25-Sep-2006	4	Editorial update.
22-Aug-2013	5	Removed DIP package and all information pertaining to it Table 1: Device summary: Removed order codes LM224AN, LM224AD, LM324AN, and LM324AD; updated packaging. Table 2: Absolute maximum ratings: removed N suffix power dissipation data; updated footnotes 5 and 6. Renamed Figure 3, Figure 4, Figure 6, Figure 7, Figure 16, Figure 17, Figure 18, and Figure 19. Updated axes titles of Figure 4, Figure 5, Figure 7, and Figure 17. Removed duplicate figures. Removed Section 5: Macromodels
06-Dec-2013	6	Table 2: Absolute maximum ratings: updated ESD data for HBM and MM.
10-Jun-2016	7	LM124, LM224, LM324 and LM224W, LM324W datasheets merged with LM224A, LM324A datasheet. The following sections were reworked: <i>Features</i> , <i>Description</i> , <i>Section 1: "Pin connections and schematic diagram"</i> , <i>Section 2: "Absolute maximum ratings and operating conditions"</i> , and <i>Section 3: "Electrical characteristics"</i> . The following sections were added: <i>Related products</i> and <i>Section 7: "Ordering information"</i> . Packaged silhouettes, pin connections, and mechanical data were standardized and updated.

**IMPORTANT NOTICE – PLEASE READ CAREFULLY**

STMicroelectronics NV and its subsidiaries ("ST") reserve the right to make changes, corrections, enhancements, modifications, and improvements to ST products and/or to this document at any time without notice. Purchasers should obtain the latest relevant information on ST products before placing orders. ST products are sold pursuant to ST's terms and conditions of sale in place at the time of order acknowledgement.

Purchasers are solely responsible for the choice, selection, and use of ST products and ST assumes no liability for application assistance or the design of Purchasers' products.

No license, express or implied, to any intellectual property right is granted by ST herein.

Resale of ST products with provisions different from the information set forth herein shall void any warranty granted by ST for such product.



ST and the ST logo are trademarks of ST. All other product or service names are the property of their respective owners.

Information in this document supersedes and replaces information previously supplied in any prior versions of this document.

© 2016 STMicroelectronics – All rights reserved

## Looking for pricing, stock, or lifecycle information?

Click below to explore more details on WIN SOURCE:

-  [View LM224QT](#) on WIN SOURCE
-  [STMicroelectronics](#) Information

## Optimize Your Supply Chain with WIN SOURCE Solutions

-  Global Sourcing Solution
-  Obsolete Management
-  Cost Control Management
-  Shortage Management
-  Alternative Solution
-  Excess Inventory Management