



**THE DATASHEET OF
LM211QDRQ1**



LM211-Q1 DIFFERENTIAL COMPARATOR WITH STROBES

SLCS143A – APRIL 2004 – REVISED APRIL 2008

- Qualified for Automotive Applications
- Fast Response Times
- Strobe Capability
- Maximum Input Bias Current . . . 150 nA
- Maximum Input Offset Current . . . 20 nA
- Can Operate From Single 5-V Supply

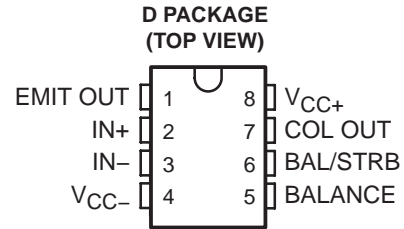

description/ordering information

The LM211 is a single high-speed voltage comparator. This device is designed to operate from a wide range of power-supply voltages, including ± 15 -V supplies for operational amplifiers and 5-V supplies for logic systems. The output levels are compatible with most TTL and MOS circuits. This comparator is capable of driving lamps or relays and switching voltages up to 50 V at 50 mA. All inputs and outputs can be isolated from system ground. The outputs can drive loads referenced to ground, V_{CC+} , or V_{CC-} . Offset balancing and strobe capabilities are available, and the outputs can be wire-OR connected. If the strobe is low, the output is in the off state, regardless of the differential input.

ORDERING INFORMATION†

T _A	V _{I/O} max AT 25°C	PACKAGE‡		ORDERABLE PART NUMBER	TOP-SIDE MARKING
-40°C to 125°C	3 mV	SOIC (D)	Reel of 2500	LM211QDRQ1	LM211Q1

† For the most current package and ordering information, see the Package Option Addendum at the end of this document, or see the TI web site at <http://www.ti.com>.

‡ Package drawings, thermal data, and symbolization are available at <http://www.ti.com/packaging>.

functional block diagram

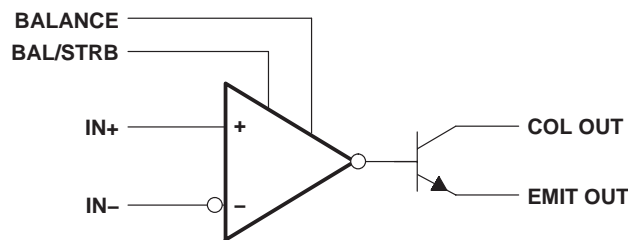

Please be aware that an important notice concerning availability, standard warranty, and use in critical applications of Texas Instruments semiconductor products and disclaimers thereto appears at the end of this data sheet.

PRODUCTION DATA information is current as of publication date. Products conform to specifications per the terms of Texas Instruments standard warranty. Production processing does not necessarily include testing of all parameters.

**TEXAS
INSTRUMENTS**

POST OFFICE BOX 655303 • DALLAS, TEXAS 75265

Copyright © 2008, Texas Instruments Incorporated

LM211-Q1 DIFFERENTIAL COMPARATOR WITH STROBES

SLCS143A – APRIL 2004 – REVISED APRIL 2008

schematic

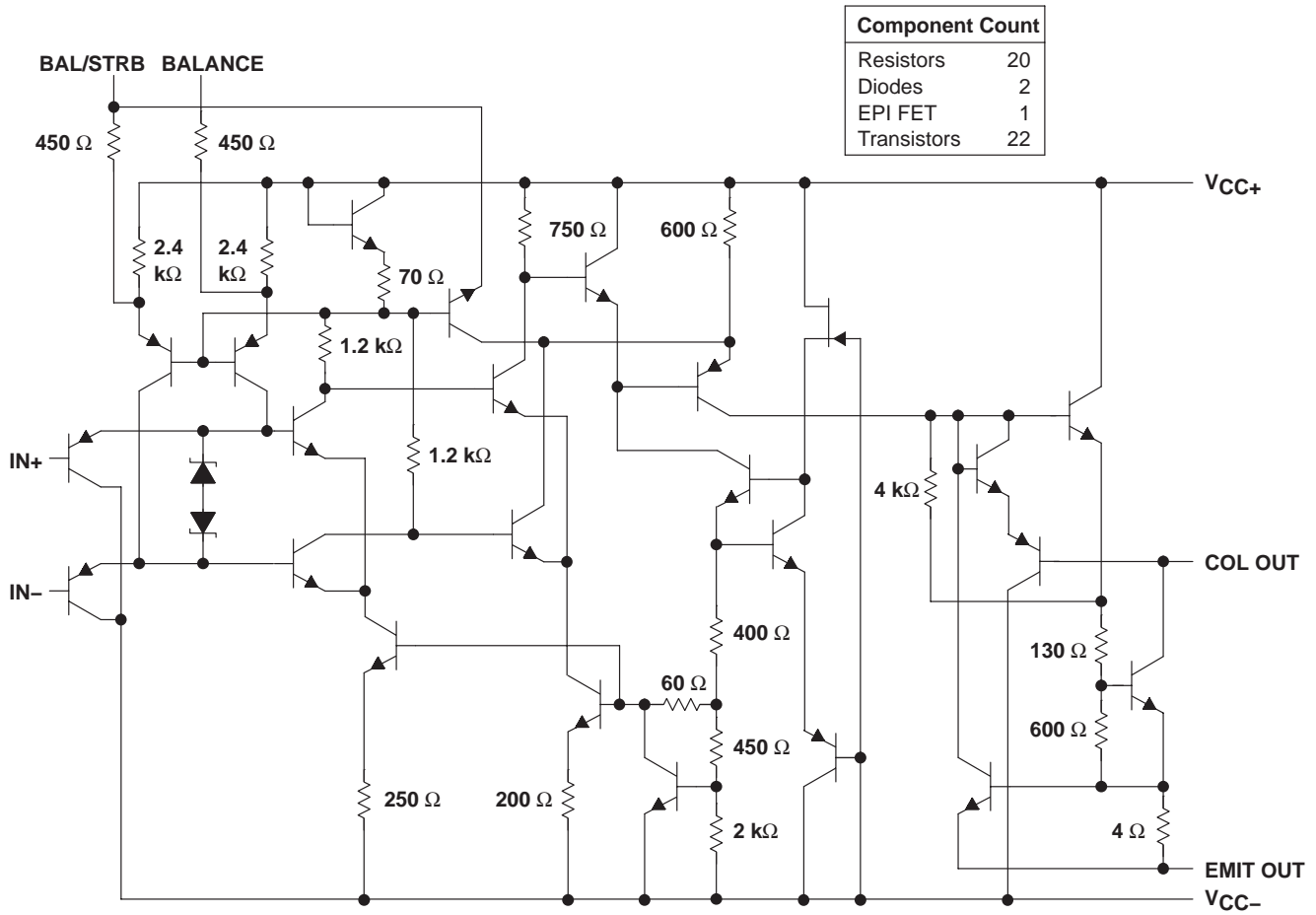

All resistor values shown are nominal.

LM211-Q1 DIFFERENTIAL COMPARATOR WITH STROBES

SLCS143A – APRIL 2004 – REVISED APRIL 2008

absolute maximum ratings over operating free-air temperature range (unless otherwise noted)†

Supply voltage: V_{CC+} (see Note 1)	18 V
V_{CC-} (see Note 1)	-18 V
$V_{CC+} - V_{CC-}$	36 V
Differential input voltage, V_{ID} (see Note 2)	± 30 V
Input voltage, V_I (either input) (see Notes 1 and 3)	± 15 V
Voltage from emitter output to V_{CC-}	30 V
Voltage from collector output to V_{CC-}	50 V
Duration of output short circuit (see Note 4)	10 s
Package thermal impedance, θ_{JA} (see Notes 5 and 6)	97°C/W
Operating virtual junction temperature, T_J	150°C
Lead temperature 1,6 mm (1/16 inch) from case for 60 seconds	260°C
Storage temperature range, T_{Stg}	-65°C to 150°C

† Stresses beyond those listed under “absolute maximum ratings” may cause permanent damage to the device. These are stress ratings only, and functional operation of the device at these or any other conditions beyond those indicated under “recommended operating conditions” is not implied. Exposure to absolute-maximum-rated conditions for extended periods may affect device reliability.

- NOTES:
1. All voltage values, unless otherwise noted, are with respect to the midpoint between V_{CC+} and V_{CC-} .
 2. Differential voltages are at $IN+$ with respect to $IN-$.
 3. The magnitude of the input voltage must never exceed the magnitude of the supply voltage or ± 15 V, whichever is less.
 4. The output may be shorted to ground or either power supply.
 5. Maximum power dissipation is a function of $T_J(max)$, θ_{JA} , and T_A . The maximum allowable power dissipation at any allowable ambient temperature is $P_D = (T_J(max) - T_A)/\theta_{JA}$. Operating at the absolute maximum T_J of 150°C can affect reliability.
 6. The package thermal impedance is calculated in accordance with JESD 51-7.

recommended operating conditions

		MIN	MAX	UNIT
$V_{CC+} - V_{CC-}$	Supply voltage	3.5	30	V
V_I	Input voltage ($ V_{CC\pm} \leq 15$ V)	$V_{CC-} + 0.5$	$V_{CC+} - 1.5$	V
T_A	Operating free-air temperature range	-40	125	°C



LM211-Q1

DIFFERENTIAL COMPARATOR WITH STROBES

SLCS143A – APRIL 2004 – REVISED APRIL 2008

electrical characteristics at specified free-air temperature, $V_{CC\pm} = \pm 15\text{ V}$ (unless otherwise noted)

PARAMETER	TEST CONDITIONS	T_A †	MIN	TYP‡	MAX	UNIT
V_{IO} Input offset voltage	See Note 7	25°C		0.7	3	mV
		Full range			4	
I_{IO} Input offset current	See Note 7	25°C		4	10	nA
		Full range			20	
I_{IB} Input bias current	$V_O = 1\text{ V to } 14\text{ V}$	25°C		75	100	nA
		Full range			150	
$I_{IL(S)}$ Low-level strobe current (see Note 8)	$V_{(\text{strobe})} = 0.3\text{ V}, V_{ID} \leq -10\text{ mV}$	25°C		-3		mA
V_{ICR} Common-mode input voltage range		Full range	13 to -14.5	13.8 to -14.7		V
A_{VD} Large-signal differential voltage amplification	$V_O = 5\text{ V to } 35\text{ V}, R_L = 1\text{ k}\Omega$	25°C	40	200		V/mV
I_{OH} High-level (collector) output leakage current	$I_{(\text{strobe})} = -3\text{ mA}, V_{ID} = 5\text{ mV}, V_{OH} = 35\text{ V}$	25°C		0.2	10	nA
		Full range			0.5	μA
	$V_{ID} = 5\text{ mV}, V_{OH} = 35\text{ V}$	25°C				nA
V_{OL} Low-level (collector-to-emitter) output voltage	$I_{OL} = 50\text{ mA}$	$V_{ID} = -5\text{ mV}$	25°C	0.75	1.5	V
		$V_{ID} = -10\text{ mV}$	25°C			
	$V_{CC+} = 4.5\text{ V}, V_{CC-} = 0, I_{OL} = 8\text{ mA}$	$V_{ID} = -6\text{ mV}$	Full range	0.23	0.4	
		$V_{ID} = -10\text{ mV}$	Full range			
I_{CC+} Supply current from V_{CC+} , output low	$V_{ID} = -10\text{ mV},$ No load	25°C		5.1	6	mA
I_{CC-} Supply current from V_{CC-} , output high	$V_{ID} = 10\text{ mV},$ No load	25°C		-4.1	-5	mA

† Unless otherwise noted, all characteristics are measured with BALANCE and BAL/STRB open and EMIT OUT grounded.

Full range for LM211Q is -40°C to 125°C.

‡ All typical values are at $T_A = 25^\circ\text{C}$.

NOTES: 7. The offset voltages and offset currents given are the maximum values required to drive the collector output up to 14 V or down to 1 V with a pullup resistor of 7.5 k Ω to V_{CC+} . These parameters actually define an error band and take into account the worst-case effects of voltage gain and input impedance.

8. The strobe should not be shorted to ground; it should be current driven at -3 mA to -5 mA (see Figures 13 and 27).

switching characteristics, $V_{CC\pm} = \pm 15\text{ V}, T_A = 25^\circ\text{C}$

PARAMETER	TEST CONDITIONS	TYP	UNIT
Response time, low-to-high-level output	$R_C = 500\ \Omega \text{ to } 5\text{ V}, C_L = 5\text{ pF},$ See Note 9	115	ns
Response time, high-to-low-level output		165	ns

NOTE 9: The response time specified is for a 100-mV input step with 5-mV overdrive and is the interval between the input step function and the instant when the output crosses 1.4 V.



TYPICAL CHARACTERISTICS

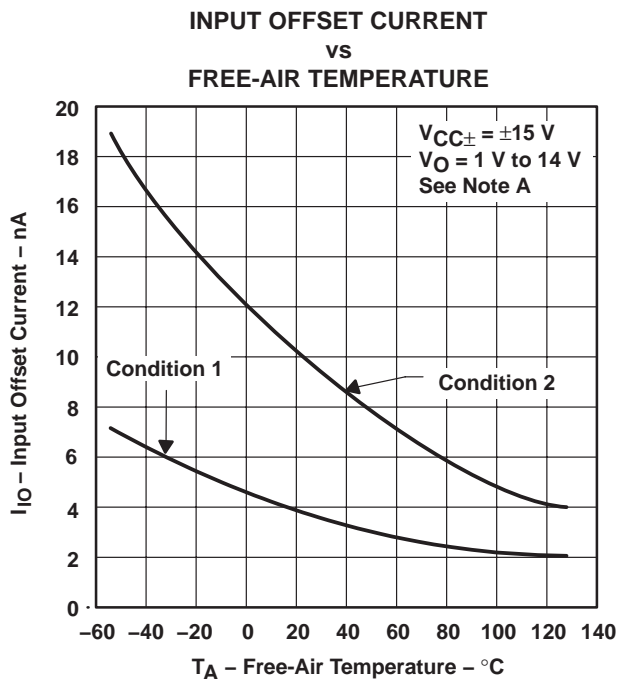

NOTE A: Condition 1 is with BALANCE and BAL/STRB open. Condition 2 is with BALANCE and BAL/STRB connected to V_{CC+}.

Figure 1

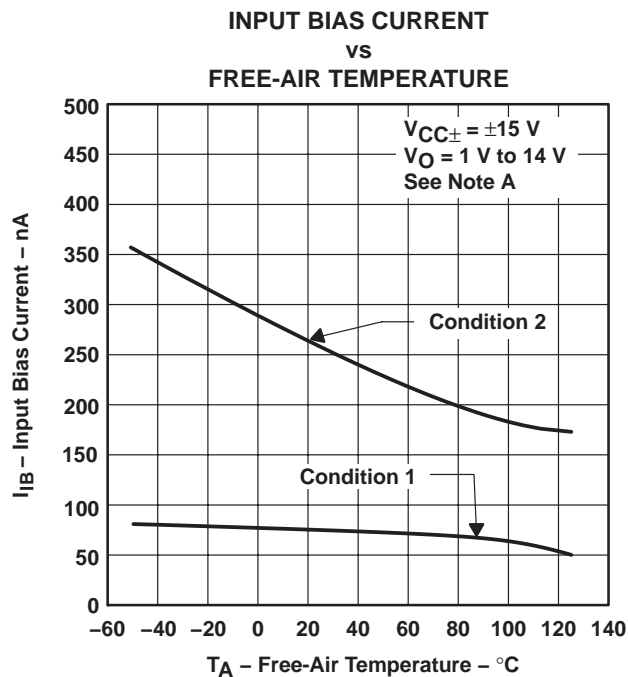

NOTE A: Condition 1 is with BALANCE and BAL/STRB open. Condition 2 is with BALANCE and BAL/STRB connected to V_{CC+}.

Figure 2

LM211-Q1 DIFFERENTIAL COMPARATOR WITH STROBES

SLCS143A – APRIL 2004 – REVISED APRIL 2008

TYPICAL CHARACTERISTICS

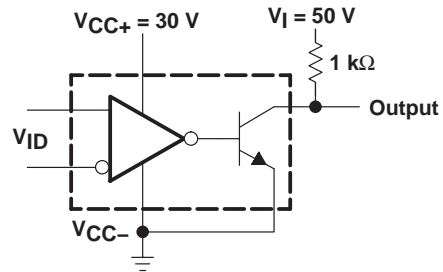
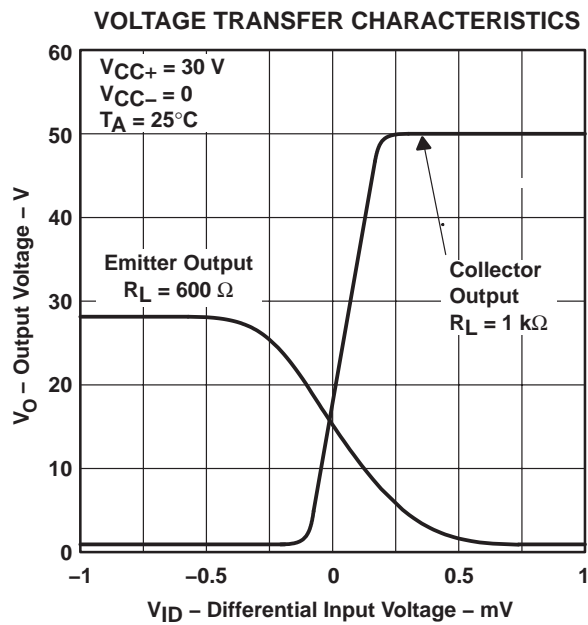

COLLECTOR OUTPUT TRANSFER CHARACTERISTIC
TEST CIRCUIT FOR FIGURE 3

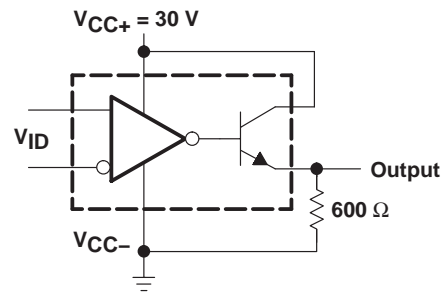

EMITTER OUTPUT TRANSFER CHARACTERISTIC
TEST CIRCUIT FOR FIGURE 3

Figure 3

TYPICAL CHARACTERISTICS

**OUTPUT RESPONSE FOR
VARIOUS INPUT OVERDRIVES**

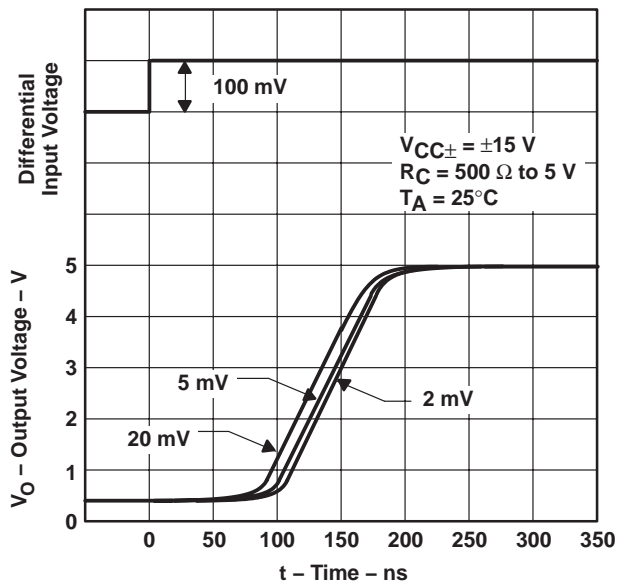

Figure 4

**OUTPUT RESPONSE FOR
VARIOUS INPUT OVERDRIVES**

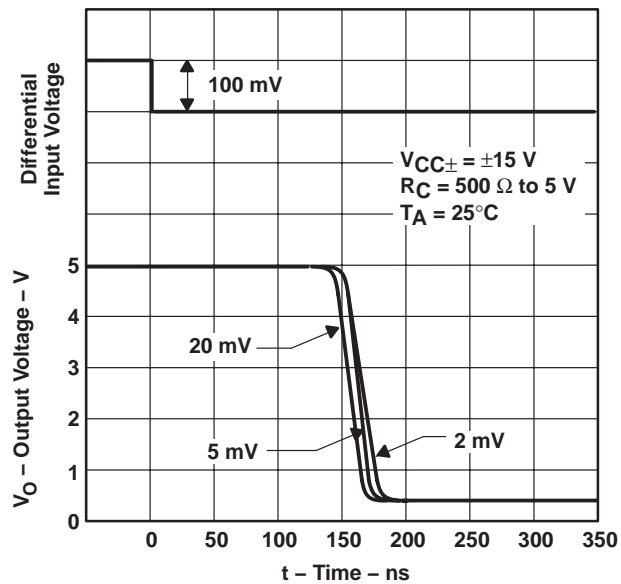
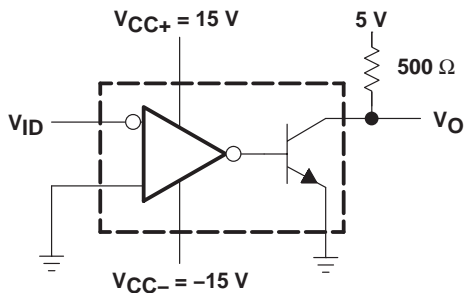

Figure 5



TEST CIRCUIT FOR FIGURES 4 AND 5

LM211-Q1 DIFFERENTIAL COMPARATOR WITH STROBES

SLCS143A – APRIL 2004 – REVISED APRIL 2008

TYPICAL CHARACTERISTICS

OUTPUT RESPONSE FOR
VARIOUS INPUT OVERDRIVES

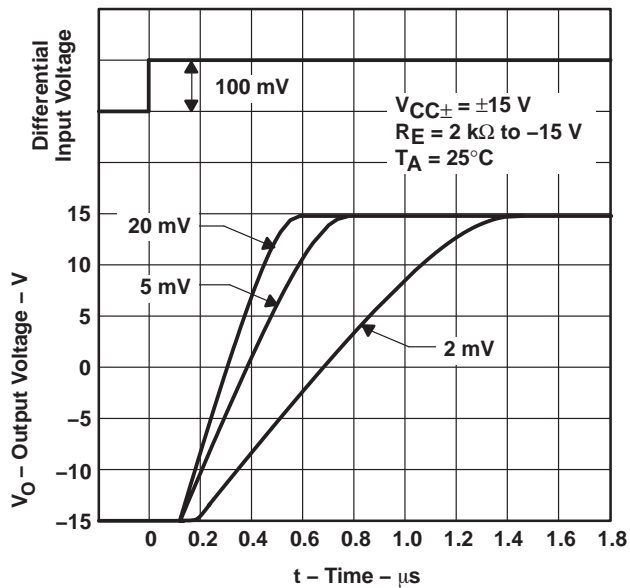

Figure 6

OUTPUT RESPONSE FOR
VARIOUS INPUT OVERDRIVES

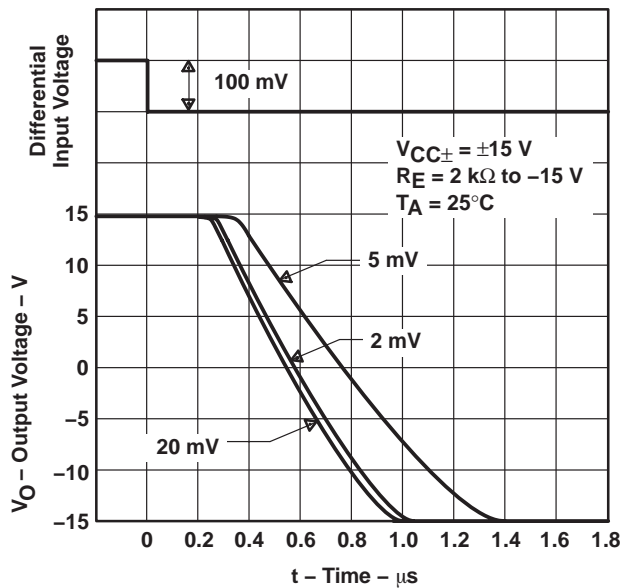
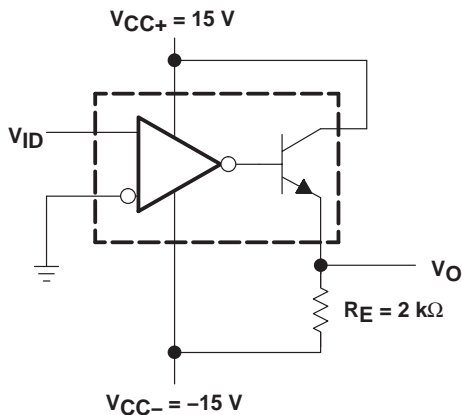

Figure 7



TEST CIRCUIT FOR FIGURES 6 AND 7

TYPICAL CHARACTERISTICS

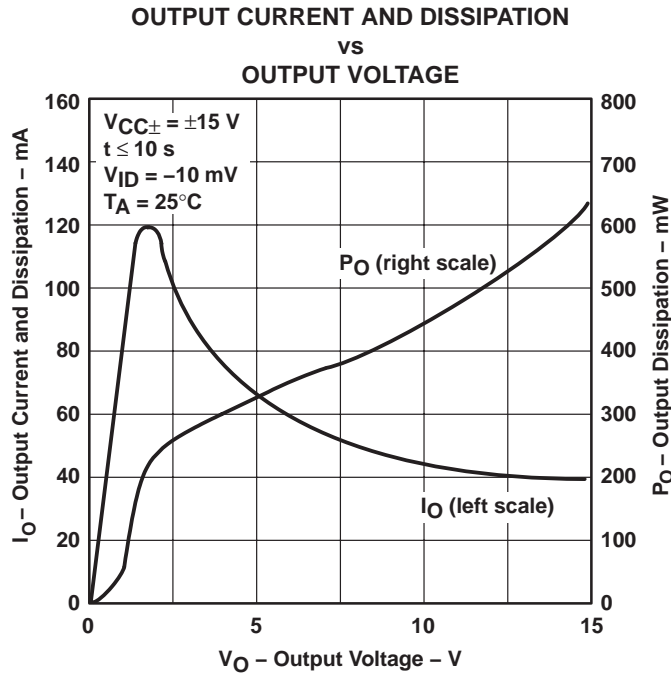

Figure 8

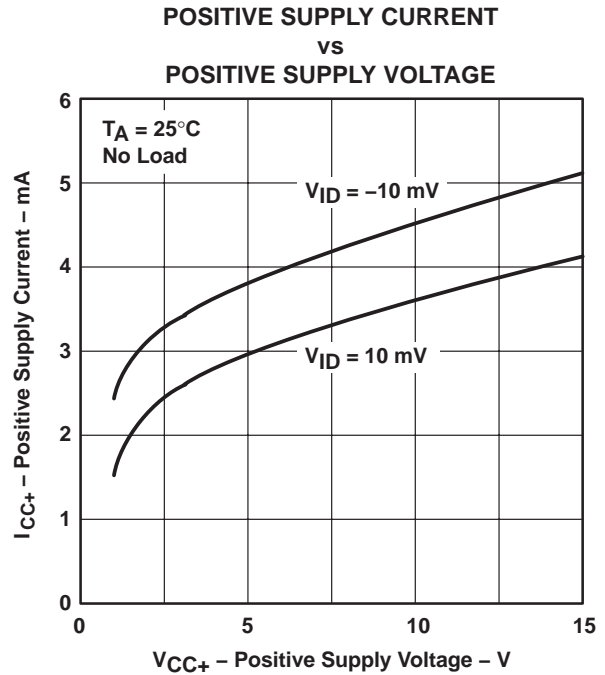

Figure 9

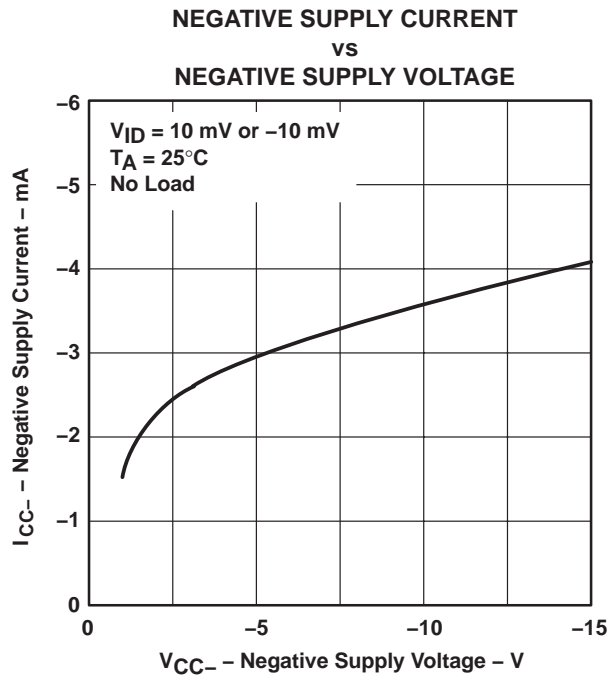

Figure 10

LM211-Q1 DIFFERENTIAL COMPARATOR WITH STROBES

SLCS143A – APRIL 2004 – REVISED APRIL 2008

APPLICATION INFORMATION

Figure 11 through Figure 29 show various applications for the LM211 comparator.

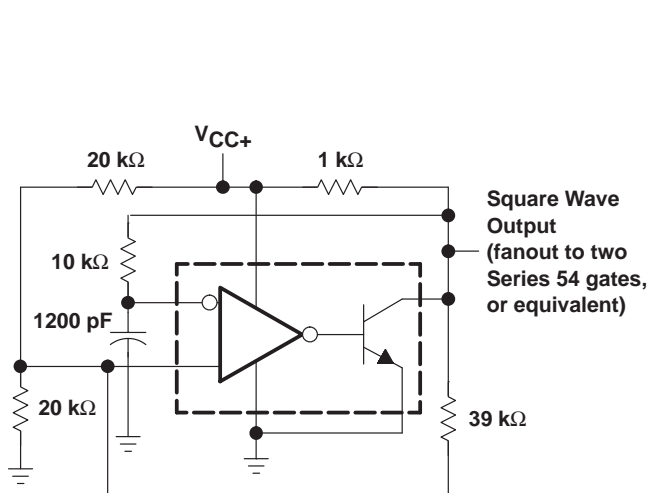
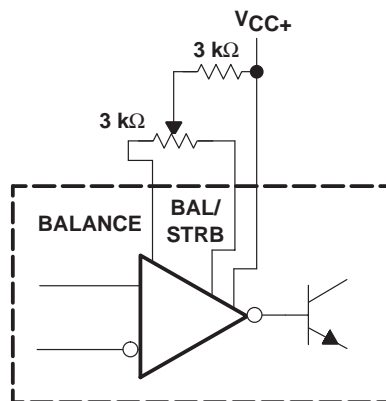
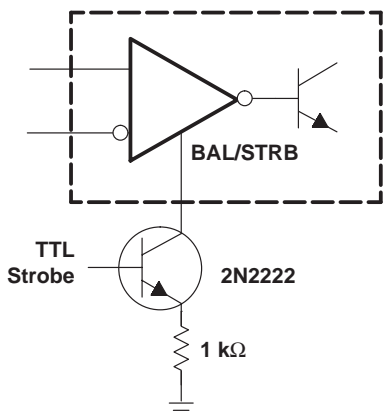

Figure 11. 100-kHz Free-Running Multivibrator



NOTE: If offset balancing is not used, the BALANCE and BAL/STRB pins should be shorted together.

Figure 12. Offset Balancing



NOTE: Do not connect strobe pin directly to ground, because the output is turned off whenever current is pulled from the strobe pin.

Figure 13. Strobming

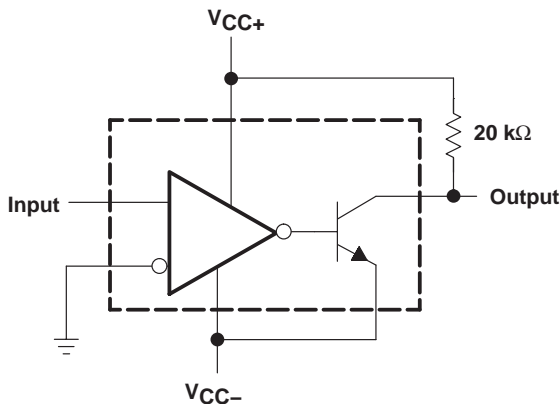
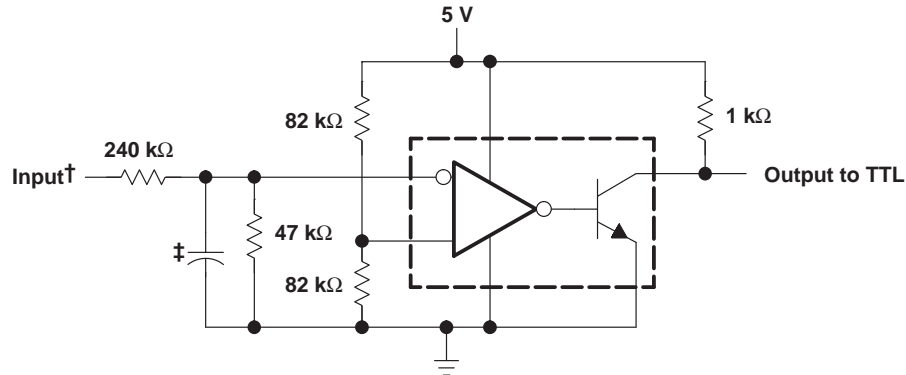

Figure 14. Zero-Crossing Detector

APPLICATION INFORMATION



† Resistor values shown are for a 0- to 30-V logic swing and a 15-V threshold.

‡ May be added to control speed and reduce susceptibility to noise spikes

Figure 15. TTL Interface With High-Level Logic

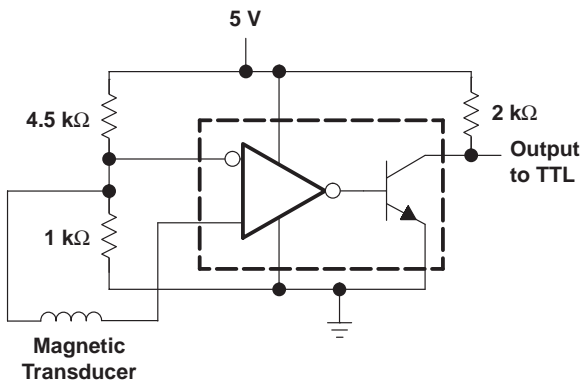

Figure 16. Detector for Magnetic Transducer

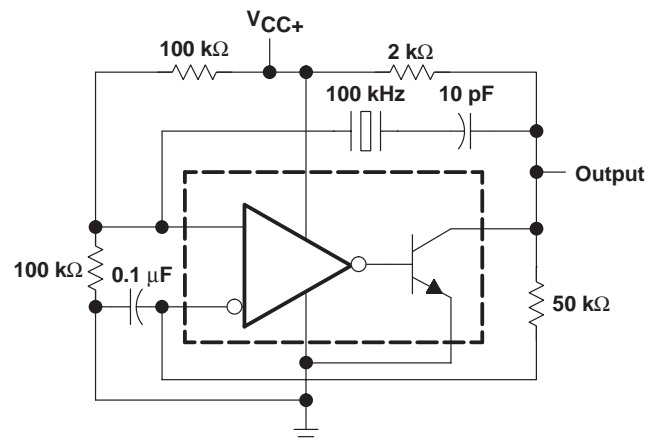

Figure 17. 100-kHz Crystal Oscillator

LM211-Q1 DIFFERENTIAL COMPARATOR WITH STROBES

SLCS143A – APRIL 2004 – REVISED APRIL 2008

APPLICATION INFORMATION

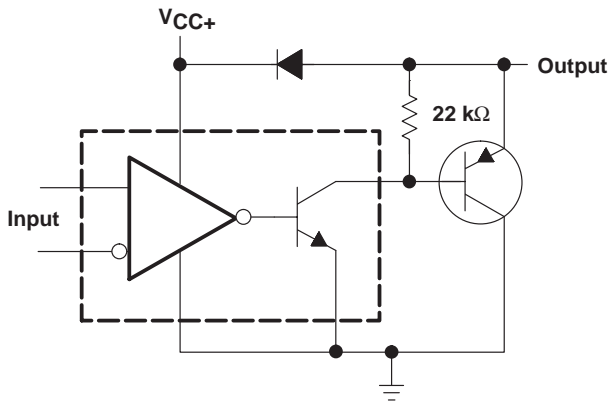
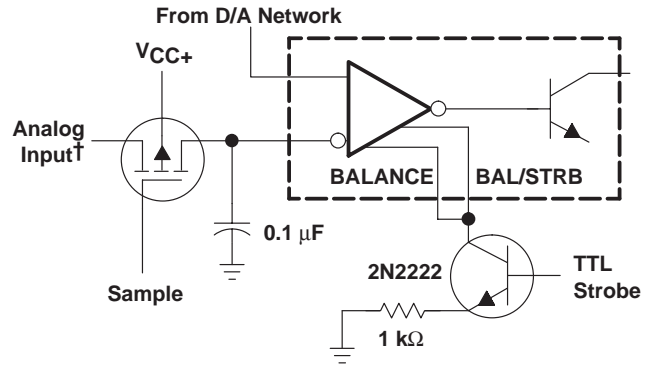

Figure 18. Comparator and Solenoid Driver



† Typical input current is 50 pA with inputs strobed off.

Figure 19. Strobing Both Input and Output Stages Simultaneously

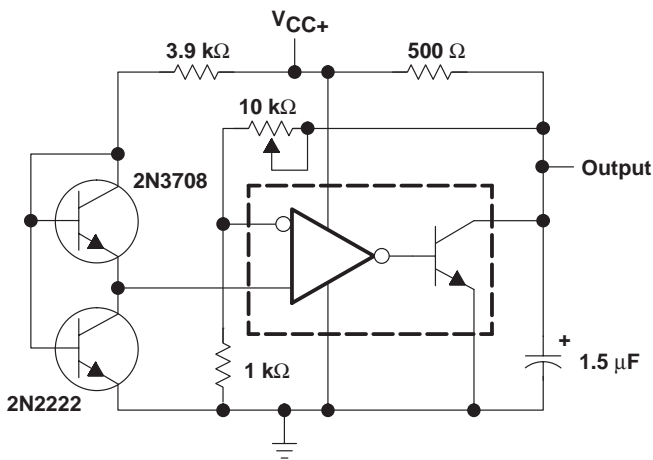

Figure 20. Low-Voltage Adjustable Reference Supply

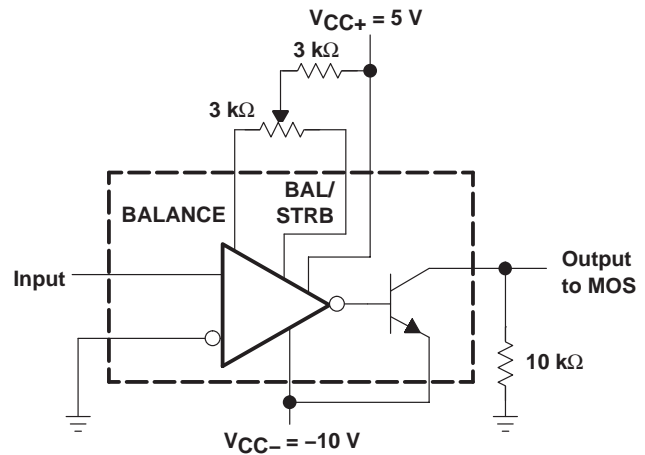
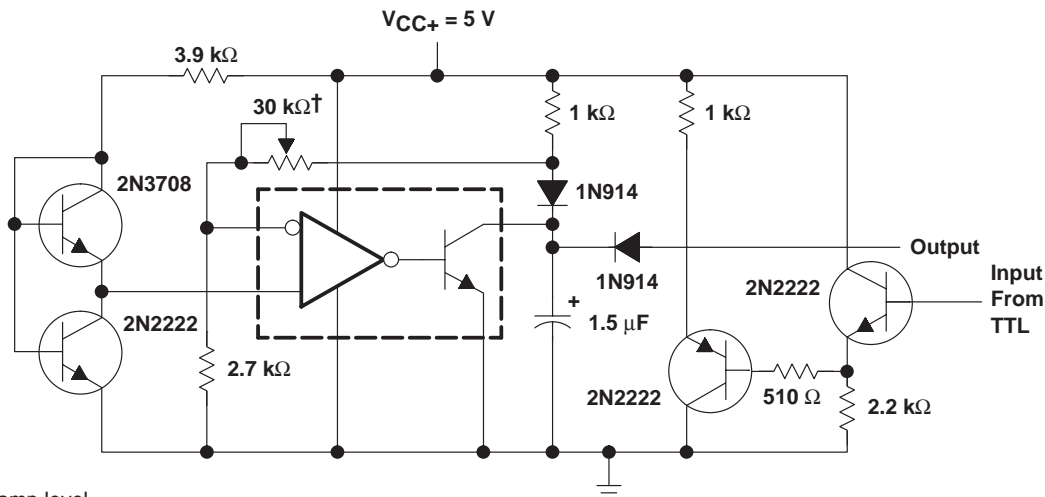

Figure 21. Zero-Crossing Detector Driving MOS Logic

APPLICATION INFORMATION



† Adjust to set clamp level

Figure 22. Precision Squarer

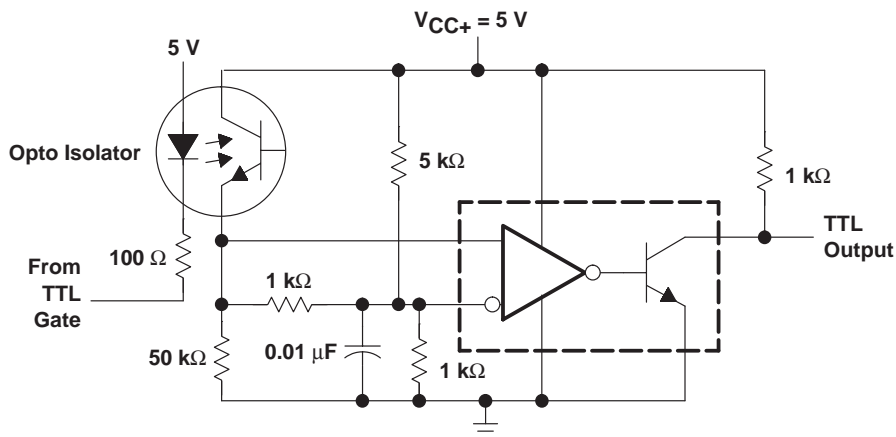

Figure 23. Digital Transmission Isolator

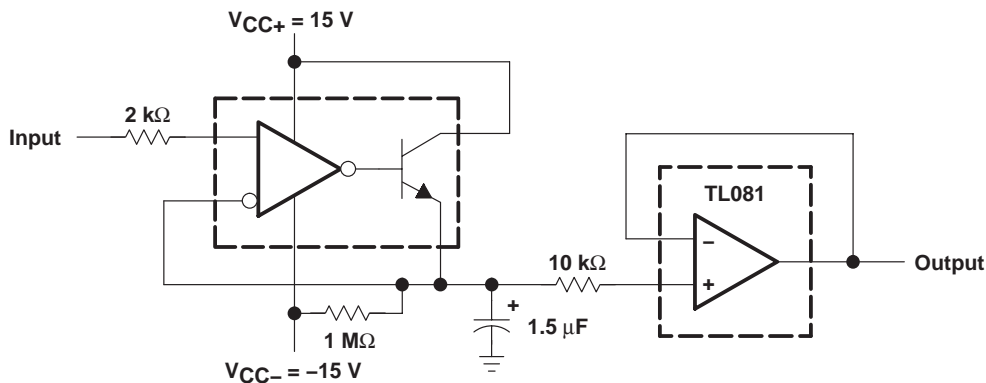

Figure 24. Positive-Peak Detector

LM211-Q1 DIFFERENTIAL COMPARATOR WITH STROBES

SLCS143A – APRIL 2004 – REVISED APRIL 2008

APPLICATION INFORMATION

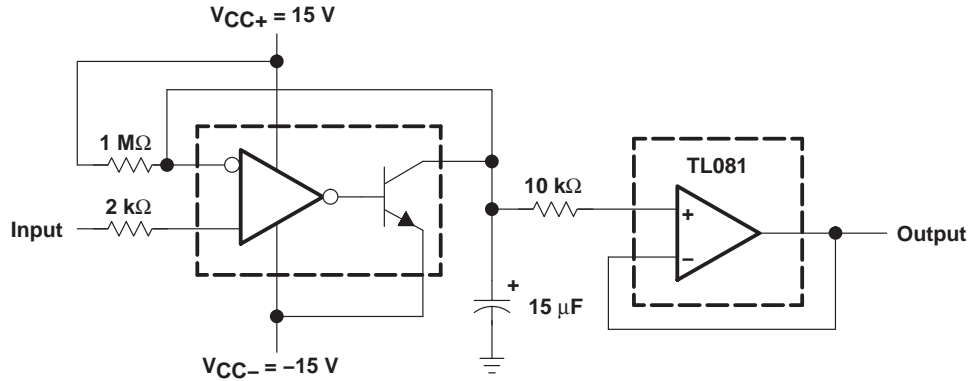
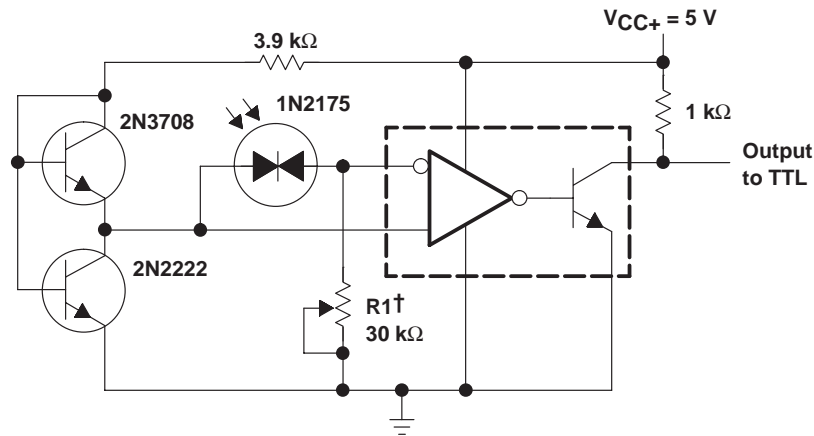
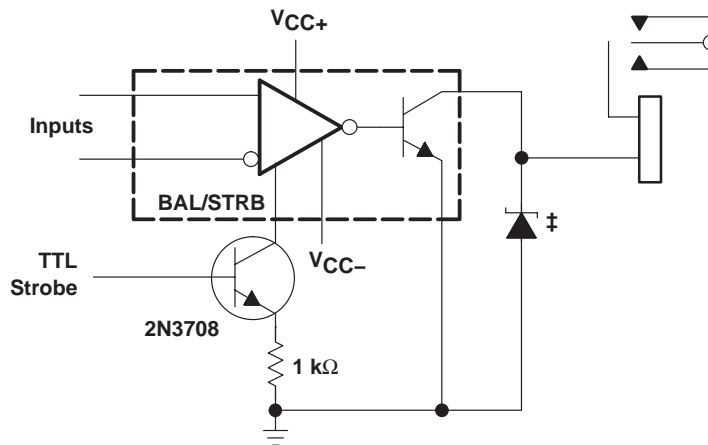

Figure 25. Negative-Peak Detector



† R1 sets the comparison level. At comparison, the photodiode has less than 5 mV across it, decreasing dark current by an order of magnitude.

Figure 26. Precision Photodiode Comparator



‡ Transient voltage and inductive kickback protection

Figure 27. Relay Driver With Strobe

APPLICATION INFORMATION

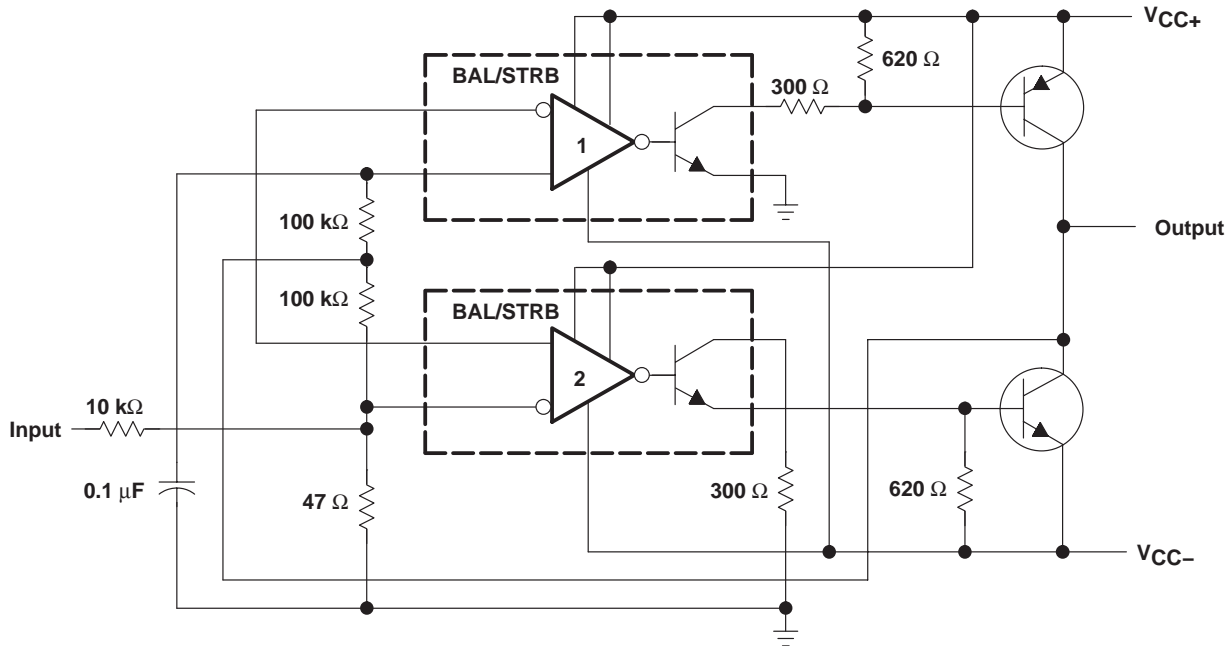

Figure 28. Switching Power Amplifier

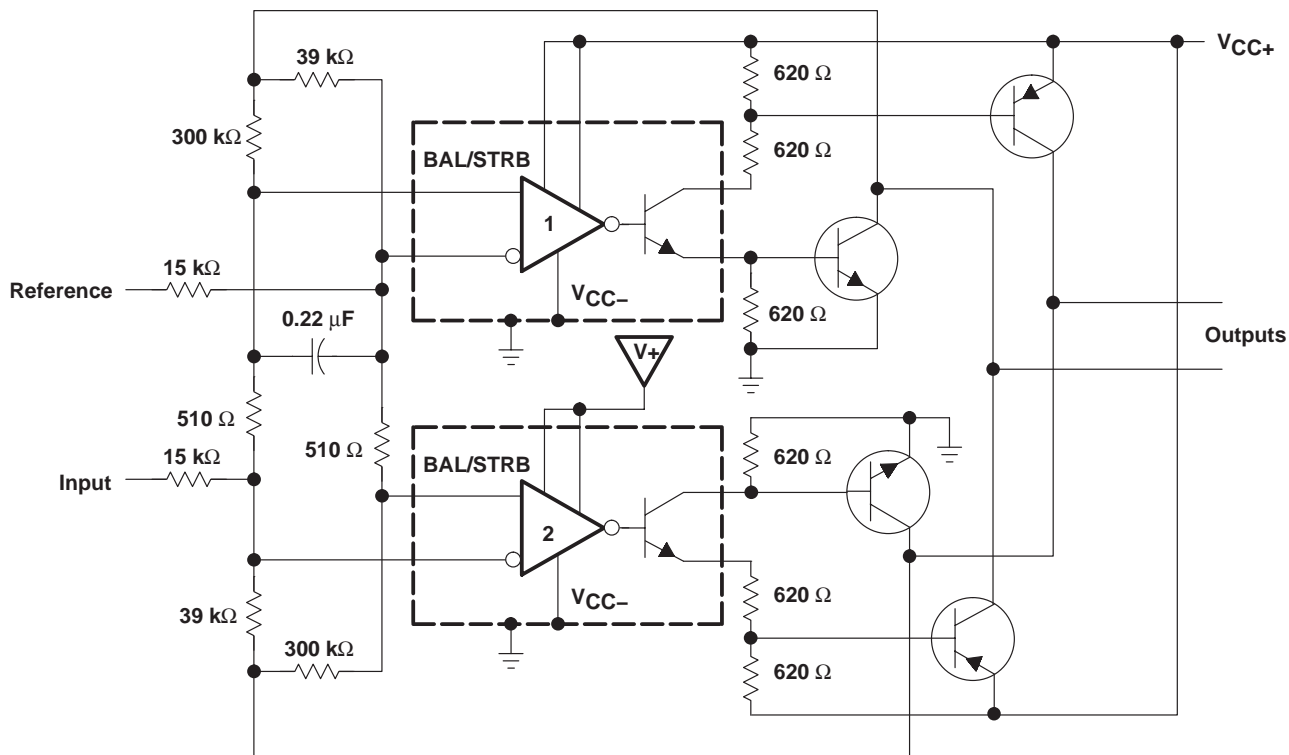

Figure 29. Switching Power Amplifiers

PACKAGING INFORMATION

Orderable Device	Status (1)	Package Type	Package Drawing	Pins	Package Qty	Eco Plan (2)	Lead/Ball Finish	MSL Peak Temp (3)	Op Temp (°C)	Top-Side Markings (4)	Samples
LM211QDRG4Q1	ACTIVE	SOIC	D	8	2500	Green (RoHS & no Sb/Br)	CU NIPDAU	Level-1-260C-UNLIM	-40 to 125	LM211Q	Samples
LM211QDRQ1	ACTIVE	SOIC	D	8	2500	Green (RoHS & no Sb/Br)	CU NIPDAU	Level-1-260C-UNLIM	-40 to 125	LM211Q	Samples

(1) The marketing status values are defined as follows:

ACTIVE: Product device recommended for new designs.

LIFEBUY: TI has announced that the device will be discontinued, and a lifetime-buy period is in effect.

NRND: Not recommended for new designs. Device is in production to support existing customers, but TI does not recommend using this part in a new design.

PREVIEW: Device has been announced but is not in production. Samples may or may not be available.

OBSOLETE: TI has discontinued the production of the device.

(2) Eco Plan - The planned eco-friendly classification: Pb-Free (RoHS), Pb-Free (RoHS Exempt), or Green (RoHS & no Sb/Br) - please check <http://www.ti.com/productcontent> for the latest availability information and additional product content details.

TBD: The Pb-Free/Green conversion plan has not been defined.

Pb-Free (RoHS): TI's terms "Lead-Free" or "Pb-Free" mean semiconductor products that are compatible with the current RoHS requirements for all 6 substances, including the requirement that lead not exceed 0.1% by weight in homogeneous materials. Where designed to be soldered at high temperatures, TI Pb-Free products are suitable for use in specified lead-free processes.

Pb-Free (RoHS Exempt): This component has a RoHS exemption for either 1) lead-based flip-chip solder bumps used between the die and package, or 2) lead-based die adhesive used between the die and leadframe. The component is otherwise considered Pb-Free (RoHS compatible) as defined above.

Green (RoHS & no Sb/Br): TI defines "Green" to mean Pb-Free (RoHS compatible), and free of Bromine (Br) and Antimony (Sb) based flame retardants (Br or Sb do not exceed 0.1% by weight in homogeneous material)

(3) MSL, Peak Temp. -- The Moisture Sensitivity Level rating according to the JEDEC industry standard classifications, and peak solder temperature.

(4) Multiple Top-Side Markings will be inside parentheses. Only one Top-Side Marking contained in parentheses and separated by a "~" will appear on a device. If a line is indented then it is a continuation of the previous line and the two combined represent the entire Top-Side Marking for that device.

Important Information and Disclaimer: The information provided on this page represents TI's knowledge and belief as of the date that it is provided. TI bases its knowledge and belief on information provided by third parties, and makes no representation or warranty as to the accuracy of such information. Efforts are underway to better integrate information from third parties. TI has taken and continues to take reasonable steps to provide representative and accurate information but may not have conducted destructive testing or chemical analysis on incoming materials and chemicals. TI and TI suppliers consider certain information to be proprietary, and thus CAS numbers and other limited information may not be available for release.

In no event shall TI's liability arising out of such information exceed the total purchase price of the TI part(s) at issue in this document sold by TI to Customer on an annual basis.

OTHER QUALIFIED VERSIONS OF LM211-Q1 :

- Catalog: [LM211](#)
- Enhanced Product: [LM211-EP](#)

NOTE: Qualified Version Definitions:

- Catalog - TI's standard catalog product
- Enhanced Product - Supports Defense, Aerospace and Medical Applications



D0008A

PACKAGE OUTLINE

SOIC - 1.75 mm max height

SMALL OUTLINE INTEGRATED CIRCUIT



4214825/C 02/2019

NOTES:

- Linear dimensions are in inches [millimeters]. Dimensions in parenthesis are for reference only. Controlling dimensions are in inches. Dimensioning and tolerancing per ASME Y14.5M.
- This drawing is subject to change without notice.
- This dimension does not include mold flash, protrusions, or gate burrs. Mold flash, protrusions, or gate burrs shall not exceed $.006$ [0.15] per side.
- This dimension does not include interlead flash.
- Reference JEDEC registration MS-012, variation AA.

EXAMPLE BOARD LAYOUT

D0008A

SOIC - 1.75 mm max height

SMALL OUTLINE INTEGRATED CIRCUIT



LAND PATTERN EXAMPLE
 EXPOSED METAL SHOWN
 SCALE:8X



SOLDER MASK DETAILS

4214825/C 02/2019

NOTES: (continued)

- 6. Publication IPC-7351 may have alternate designs.
- 7. Solder mask tolerances between and around signal pads can vary based on board fabrication site.

EXAMPLE STENCIL DESIGN

D0008A

SOIC - 1.75 mm max height

SMALL OUTLINE INTEGRATED CIRCUIT



SOLDER PASTE EXAMPLE
BASED ON .005 INCH [0.125 MM] THICK STENCIL
SCALE:8X

4214825/C 02/2019

NOTES: (continued)

8. Laser cutting apertures with trapezoidal walls and rounded corners may offer better paste release. IPC-7525 may have alternate design recommendations.
9. Board assembly site may have different recommendations for stencil design.

IMPORTANT NOTICE AND DISCLAIMER

TI PROVIDES TECHNICAL AND RELIABILITY DATA (INCLUDING DATASHEETS), DESIGN RESOURCES (INCLUDING REFERENCE DESIGNS), APPLICATION OR OTHER DESIGN ADVICE, WEB TOOLS, SAFETY INFORMATION, AND OTHER RESOURCES "AS IS" AND WITH ALL FAULTS, AND DISCLAIMS ALL WARRANTIES, EXPRESS AND IMPLIED, INCLUDING WITHOUT LIMITATION ANY IMPLIED WARRANTIES OF MERCHANTABILITY, FITNESS FOR A PARTICULAR PURPOSE OR NON-INFRINGEMENT OF THIRD PARTY INTELLECTUAL PROPERTY RIGHTS.

These resources are intended for skilled developers designing with TI products. You are solely responsible for (1) selecting the appropriate TI products for your application, (2) designing, validating and testing your application, and (3) ensuring your application meets applicable standards, and any other safety, security, or other requirements. These resources are subject to change without notice. TI grants you permission to use these resources only for development of an application that uses the TI products described in the resource. Other reproduction and display of these resources is prohibited. No license is granted to any other TI intellectual property right or to any third party intellectual property right. TI disclaims responsibility for, and you will fully indemnify TI and its representatives against, any claims, damages, costs, losses, and liabilities arising out of your use of these resources.

TI's products are provided subject to TI's Terms of Sale (www.ti.com/legal/termsofsale.html) or other applicable terms available either on ti.com or provided in conjunction with such TI products. TI's provision of these resources does not expand or otherwise alter TI's applicable warranties or warranty disclaimers for TI products.

Mailing Address: Texas Instruments, Post Office Box 655303, Dallas, Texas 75265
Copyright © 2019, Texas Instruments Incorporated

Looking for pricing, stock, or lifecycle information?

Click below to explore more details on WIN SOURCE:

 [View LM211QDRQ1](#) on WIN SOURCE

 [Texas Instruments](#) Information

Optimize Your Supply Chain with WIN SOURCE Solutions

-  Global Sourcing Solution
-  Obsolete Management
-  Cost Control Management
-  Shortage Management
-  Alternative Solution
-  Excess Inventory Management