



**THE DATASHEET OF**  
**LM1881M**



## LM1881 Video Sync Separator

### 1 Features

- AC Coupled Composite Input Signal
- >10-k $\Omega$  Input Resistance
- <10-mA Power Supply Drain Current
- Composite Sync and Vertical Outputs
- Odd and Even Field Output
- Burst Gate or Back Porch Output
- Horizontal Scan Rates to 150 kHz
- Edge Triggered Vertical Output
- Default Triggered Vertical Output for Non-Standard Video Signal (Video Games-Home Computers)

### 2 Applications

- Video Cameras and Recorders
- Broadcasting Systems
- Set-Top Boxes
- Home Entertainment
- Computing and Gaming Applications

### 3 Description

The LM1881 Video sync separator extracts timing information including composite and vertical sync, burst or back porch timing, and odd and even field information from standard negative going sync NTSC, PAL <sup>(1)</sup> and SECAM video signals with amplitude from 0.5-V to 2-V p-p. The integrated circuit is also capable of providing sync separation for non-standard, faster horizontal rate video signals. The vertical output is produced on the rising edge of the first serration in the vertical sync period. A default vertical output is produced after a time delay if the rising edge mentioned above does not occur within the externally set delay period, such as might be the case for a non-standard video signal.

#### Device Information<sup>(1)</sup>

PART NUMBER	PACKAGE	BODY SIZE (NOM)
LM1881	SOIC (8)	4.90 mm x 3.91 mm
	PDIP (8)	9.81 mm x 6.35 mm

(1) For all available packages, see the orderable addendum at the end of the data sheet.

(1) PAL in this datasheet refers to European broadcast TV standard "Phase Alternating Line", and not to Programmable Array Logic.

#### Typical Connection Diagram

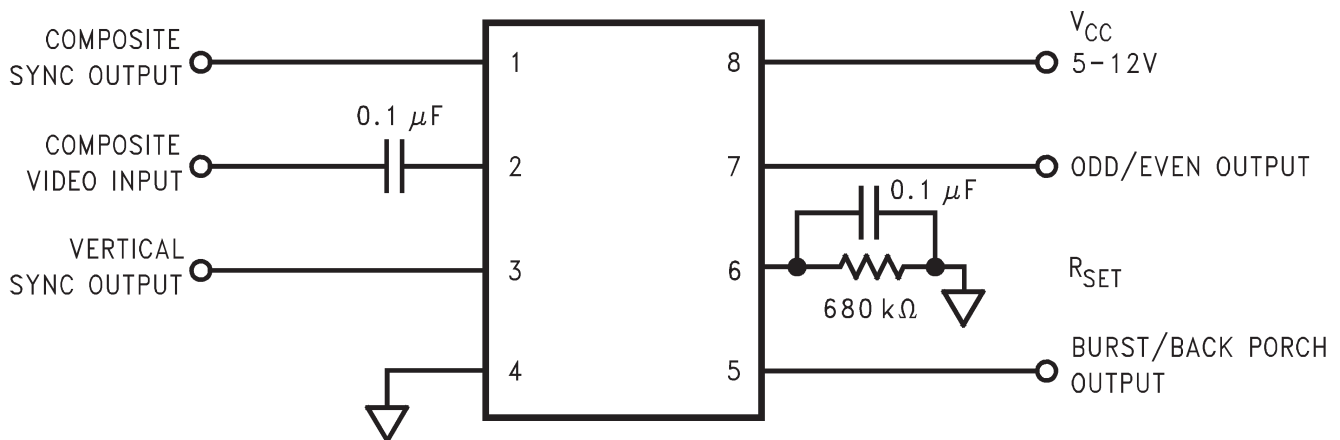

## Table of Contents

<b>1 Features</b> .....	<b>1</b>	7.2 Functional Block Diagram .....	<b>6</b>
<b>2 Applications</b> .....	<b>1</b>	7.3 Feature Description.....	<b>7</b>
<b>3 Description</b> .....	<b>1</b>	7.4 Device Functional Modes.....	<b>10</b>
<b>4 Revision History</b> .....	<b>2</b>	<b>8 Application and Implementation</b> .....	<b>11</b>
<b>5 Pin Configuration and Functions</b> .....	<b>3</b>	8.1 Application Information.....	<b>11</b>
<b>6 Specifications</b> .....	<b>3</b>	8.2 Typical Applications .....	<b>11</b>
6.1 Absolute Maximum Ratings .....	<b>3</b>	<b>9 Power Supply Recommendations</b> .....	<b>13</b>
6.2 ESD Ratings.....	<b>4</b>	<b>10 Device and Documentation Support</b> .....	<b>14</b>
6.3 Recommended Operating Conditions .....	<b>4</b>	10.1 Community Resources.....	<b>14</b>
6.4 Electrical Characteristics LM1881.....	<b>4</b>	10.2 Trademarks .....	<b>14</b>
6.5 Dissipation Ratings .....	<b>4</b>	10.3 Electrostatic Discharge Caution.....	<b>14</b>
6.6 Typical Characteristics .....	<b>5</b>	10.4 Glossary .....	<b>14</b>
<b>7 Detailed Description</b> .....	<b>6</b>	<b>11 Mechanical, Packaging, and Orderable Information</b> .....	<b>14</b>
7.1 Overview .....	<b>6</b>		

## 4 Revision History

NOTE: Page numbers for previous revisions may differ from page numbers in the current version.

<b>Changes from Revision F (March 2013) to Revision G</b>	<b>Page</b>
<ul style="list-style-type: none"> <li>Added <i>Pin Configuration and Functions</i> section, <i>ESD Ratings</i> table, <i>Feature Description</i> section, <i>Device Functional Modes</i>, <i>Application and Implementation</i> section, <i>Power Supply Recommendations</i> section, <i>Layout</i> section, <i>Device and Documentation Support</i> section, and <i>Mechanical, Packaging, and Orderable Information</i> section .....</li> </ul>	<b>1</b>

<b>Changes from Revision E (March 2013) to Revision F</b>	<b>Page</b>
<ul style="list-style-type: none"> <li>Changed layout of National Data Sheet to TI format .....</li> </ul>	<b>13</b>

## 5 Pin Configuration and Functions

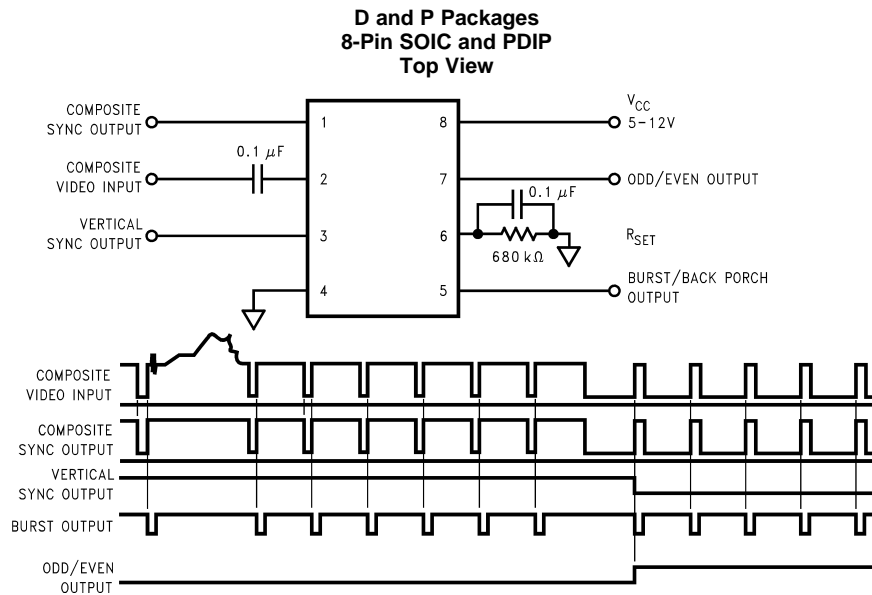

**Pin Functions**

PIN		TYPE	DESCRIPTION
NO.	NAME		
1	CSOUT	Output	Composite Sync Output
2	CVIN	Input	Composite Video Input
3	VSOUT	Output	Vertical Sync Output
4	GND	—	Ground
5	BPOUT	Output	Burst or Back Porch Timing Output
6	RSET	Input	Charge Current External Resistor
7	OEOUT	Output	Odd and Even Field Output
8	VCC	Input	Supply Voltage

## 6 Specifications

### 6.1 Absolute Maximum Ratings

over operating free-air temperature range (unless otherwise noted)<sup>(1)(2)</sup>

			MIN	MAX	UNIT
Supply Voltage				13.2	V
Input Voltage			3 V <sub>P-P</sub> (V <sub>CC</sub> = 5)	6 V <sub>P-P</sub> (V <sub>CC</sub> ≥ 8)	V
Output Sink Currents; Pins, 1, 3, 5				5	mA
Output Sink Current; Pin 7				2	mA
Soldering Information	PDIP Package (10 sec.)			260	°C
	SOIC Package	Vapor Phase (60 sec.)		215	
		Infrared (15 sec.)		220	
Storage temperature, T <sub>stg</sub>			-65	150	°C

(1) Stresses beyond those listed under *Absolute Maximum Ratings* may cause permanent damage to the device. These are stress ratings only, which do not imply functional operation of the device at these or any other conditions beyond those indicated under *Recommended Operating Conditions*. Exposure to absolute-maximum-rated conditions for extended periods may affect device reliability.

(2) If Military/Aerospace specified devices are required, please contact the TI Sales Office/ Distributors for availability and specifications.

## 6.2 ESD Ratings

		VALUE	UNIT
$V_{(ESD)}$ Electrostatic discharge	Human body model (HBM), per ANSI/ESDA/JEDEC JS-001 <sup>(1)</sup>	±2000	V
	Machine Model	±200	

(1) JEDEC document JEP155 states that 500-V HBM allows safe manufacturing with a standard ESD control process.

## 6.3 Recommended Operating Conditions

over operating free-air temperature range (unless otherwise noted)

		MIN	MAX	UNIT
$T_A$	Operating free-air temperature	0	70	°C

## 6.4 Electrical Characteristics LM1881

$V_{CC} = 5\text{ V}$ ;  $R_{SET} = 680\text{ k}\Omega$ ;  $T_A = 0^\circ\text{C}$  to  $+70^\circ\text{C}$  by correlation with 100% electrical testing at  $T_A = 25^\circ\text{C}$

PARAMETER	TEST CONDITIONS		MIN	TYP <sup>(1)</sup>	MAX	UNIT
Supply Current	Outputs at Logic 1	$V_{CC} = 5\text{ V}$		5.2	10	mA
		$V_{CC} = 12\text{ V}$		5.5	12	
DC Input Voltage	Pin 2		1.3	1.5	1.8	V
Input Threshold Voltage	See <sup>(2)</sup>		55	70	85	mV
Input Discharge Current	Pin 2; $V_{IN} = 2\text{ V}$		6	11	16	$\mu\text{A}$
Input Clamp Charge Current	Pin 2; $V_{IN} = 1\text{ V}$		0.2	0.8		mA
$R_{SET}$ Pin Reference Voltage	Pin 6; <sup>(3)</sup>		1.1	1.22	1.35	V
Composite Sync. & Vertical Outputs	$I_{OUT} = 40\text{ }\mu\text{A}$ ; Logic 1	$V_{CC} = 5\text{ V}$	4.0	4.5		V
		$V_{CC} = 12\text{ V}$	11			
	$I_{OUT} = 1.6\text{ mA}$ Logic 1	$V_{CC} = 5\text{ V}$	2.4	3.6		V
		$V_{CC} = 12\text{ V}$	10			
Burst Gate and Odd and Even Outputs	$I_{OUT} = 40\text{ }\mu\text{A}$ ; Logic 1	$V_{CC} = 5\text{ V}$	4	4.5		V
		$V_{CC} = 12\text{ V}$	11			
Composite Sync. Output	$I_{OUT} = -1.6\text{ mA}$ ; Logic 0; Pin 1		0.2	0.8		V
Vertical Sync. Output	$I_{OUT} = -1.6\text{ mA}$ ; Logic 0; Pin 3		0.2	0.8		V
Burst Gate Output	$I_{OUT} = -1.6\text{ mA}$ ; Logic 0; Pin 5		0.2	0.8		V
Odd and Even Output	$I_{OUT} = -1.6\text{ mA}$ ; Logic 0; Pin 7		0.2	0.8		V
Vertical Sync Width			190	230	300	$\mu\text{s}$
Burst Gate Width	2.7 k $\Omega$ from Pin 5 to $V_{CC}$		2.5	4	4.7	$\mu\text{s}$
Vertical Default Time	See <sup>(4)</sup>		32	65	90	$\mu\text{s}$

(1) Typicals are at  $T_J = 25^\circ\text{C}$  and represent the most likely parametric norm.

(2) Relative difference between the input clamp voltage and the minimum input voltage which produces a horizontal output pulse.

(3) Careful attention should be made to prevent parasitic capacitance coupling from any output pin (Pins 1, 3, 5 and 7) to the  $R_{SET}$  pin (Pin 6).

(4) Delay time between the start of vertical sync (at input) and the vertical output pulse.

## 6.5 Dissipation Ratings

		MIN	MAX	UNIT
Package Dissipation <sup>(1)</sup>			1100	mW

(1) For operation in ambient temperatures above  $25^\circ\text{C}$ , the device must be derated based on a  $150^\circ\text{C}$  maximum junction temperature and a package thermal resistance of  $110^\circ\text{C}/\text{W}$ , junction to ambient.

## 6.6 Typical Characteristics

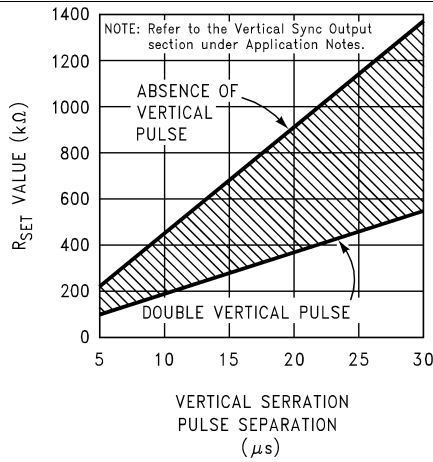

Figure 1. R<sub>SET</sub> Value Selection vs Vertical Serration Pulse Separation

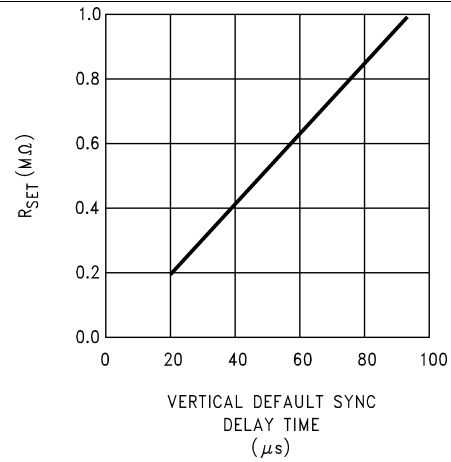

Figure 2. Vertical Default Sync Delay Time vs R<sub>SET</sub>

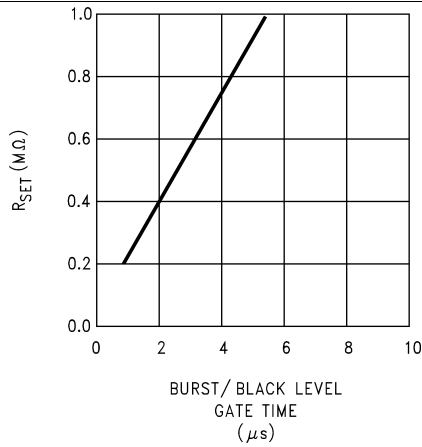

Figure 3. Burst or Black Level Gate Time vs R<sub>SET</sub>

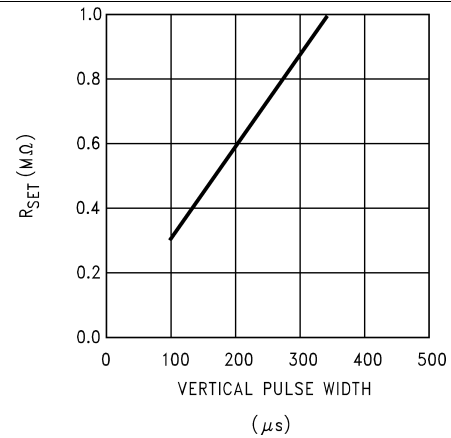

Figure 4. Vertical Pulse Width vs R<sub>SET</sub>

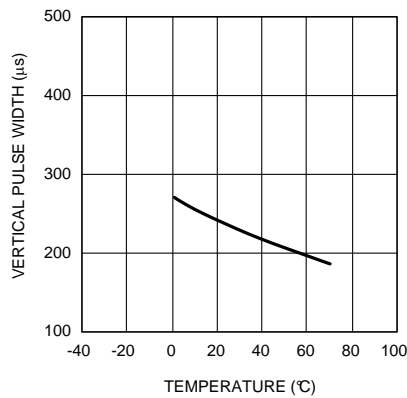

Figure 5. Vertical Pulse Width vs Temperature

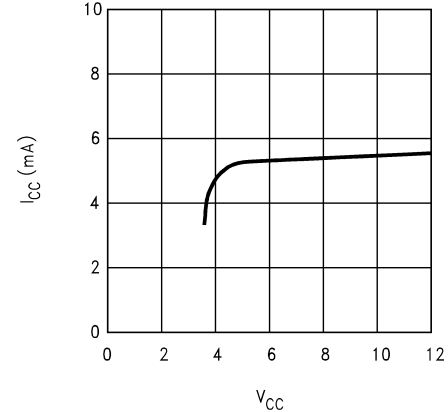

Figure 6. Supply Current vs Supply Voltage



## 7.3 Feature Description

### 7.3.1 Composite Sync Output

The composite sync output, [Figure 7\(b\)](#), is simply a reproduction of the signal waveform below the composite video black level, with the video completely removed. This is obtained by clamping the video signal sync tips to 1.5-V DC at Pin 2 and using a comparator threshold set just above this voltage to strip the sync signal, which is then buffered out to Pin 1. The threshold separation from the clamped sync tip is nominally 70 mV which means that for the minimum input level of 0.5 V (p-p), the clipping level is close to the halfway point on the sync pulse amplitude (shown by the dashed line on [Figure 7\(a\)](#)). This threshold separation is independent of the signal amplitude, therefore, for a 2-V (p-p) input the clipping level occurs at 11% of the sync pulse amplitude. The charging current for the input coupling capacitor is 0.8 mA,

Normally the signal source for the LM1881 is assumed to be clean and relatively noise-free, but some sources may have excessive video peaking, causing high-frequency video and chroma components to extend below the black level reference. Some video discs keep the chroma burst pulse present throughout the vertical blanking period so that the burst actually appears on the sync tips for three line periods instead of at black level. A clean composite sync signal can be generated from these sources by filtering the input signal. When the source impedance is low, typically 75  $\Omega$ , a 620- $\Omega$  resistor in series with the source and a 510-pF capacitor to ground will form a lowpass filter with a corner frequency of 500 kHz. This bandwidth is more than sufficient to pass the sync pulse portion of the waveform; however, any subcarrier content in the signal will be attenuated by almost 18 dB, effectively taking it below the comparator threshold. Filtering will also help if the source is contaminated with thermal noise. The output waveforms will become delayed from between 40 ns to as much as 200 ns due to this filter. This much delay will not usually be significant but it does contribute to the sync delay produced by any additional signal processing. Because the original video may also undergo processing, the need for time delay correction will depend on the total system, not just the sync stripper.

### 7.3.2 Vertical Sync Output

A vertical sync output is derived by internally integrating the composite sync waveform ([Functional Block Diagram](#)). To understand the generation of the vertical sync pulse, refer to the lower left hand section [Functional Block Diagram](#). Note there are two comparators in the section. One comparator has an internally generated voltage reference called  $V_1$  going to one of its inputs. The other comparator has an internally generated voltage reference called  $V_2$  going to one of its inputs. Both comparators have a common input at their noninverting input coming from the internal integrator. The internal integrator is used for integrating the composite sync signal. This signal comes from the input side of the composite sync buffer and are **positive** going sync pulses. The capacitor to the integrator is internal to the LM1881. The capacitor charge current is set by the value of the external resistor  $R_{SET}$ . The output of the integrator is going to be at a low voltage during the normal horizontal lines because the integrator has a very short time to charge the capacitor, which is during the horizontal sync period. The equalization pulses will keep the output voltage of the integrator at about the same level, below the  $V_1$ . During the vertical sync period the narrow going positive pulses shown in [Figure 7](#) is called the serration pulse. The wide negative portion of the vertical sync period is called the vertical sync pulse. At the start of the vertical sync period, before the first Serration pulse occurs, the integrator now charges the capacitor to a much higher voltage. At the first serration pulse the integrator output should be between  $V_1$  and  $V_2$ . This would give a high level at the output of the comparator with  $V_1$  as one of its inputs. This high is clocked into the “D” flip-flop by the falling edge of the serration pulse (remember the sync signal is inverted in this section of the LM1881). The “Q” output of the “D” flip-flop goes through the OR gate, and sets the R/S flip-flop. The output of the R/S flip-flop enables the internal oscillator and also clocks the ODD/EVEN “D” flip-flop. The ODD/EVEN field pulse operation is covered in [Odd and Even Field Pulse](#). The output of the oscillator goes to a divide by 8 circuit, thus resetting the R/S flip-flop after 8 cycles of the oscillator. The frequency of the oscillator is established by the internal capacitor going to the oscillator and the external  $R_{SET}$ . The “ $\overline{Q}$ ” output of the R/S flip-flop goes to pin 3 and is the actual vertical sync output of the LM1881. By clocking the “D” flip-flop at the start of the first serration pulse means that the vertical sync output pulse starts at this point in time and lasts for eight cycles of the internal oscillator as shown in [Figure 7](#).

## Feature Description (continued)

How  $R_{SET}$  affects the integrator and the internal oscillator is shown under the Typical Performance Characteristics. The first graph is “ $R_{SET}$  Value Selection vs Vertical Serration Pulse Separation”. For this graph to be valid, the vertical sync pulse should last for at least 85% of the horizontal half line (47% of a full horizontal line). A vertical sync pulse from any standard should meet this requirement; both NTSC and PAL do meet this requirement (the serration pulse is the remainder of the period, 10% to 15% of the horizontal half line). Remember this pulse is a positive pulse at the integrator but negative in [Figure 7](#). This graph shows how long it takes the integrator to charge its internal capacitor above  $V_1$ .

With  $R_{SET}$  too large the charging current of the integrator will be too small to charge the capacitor above  $V_1$ , thus there will be no vertical synch output pulse. As mentioned above,  $R_{SET}$  also sets the frequency of the internal oscillator. If the oscillator runs too fast its eight cycles will be shorter than the vertical sync portion of the composite sync. Under this condition another vertical sync pulse can be generated on one of the later serration pulse after the divide by 8 circuit resets the R/S flip-flop. The first graph also shows the minimum  $R_{SET}$  necessary to prevent a double vertical pulse, assuming that the serration pulses last for only three full horizontal line periods (six serration pulses for NTSC). The actual pulse width of the vertical sync pulse is shown in the “Vertical Pulse Width vs  $R_{SET}$ ” graph. Using NTSC as an example, lets see how these two graphs relate to each other. The Horizontal line is 64  $\mu\text{s}$  long, or 32  $\mu\text{s}$  for a horizontal half line. Now round this off to 30  $\mu\text{s}$ . In the “ $R_{SET}$  Value Selection vs Vertical Serration Pulse Separation” graph the minimum resistor value for 30  $\mu\text{s}$  serration pulse separation is about 550 k $\Omega$ . Going to the “Vertical Pulse Width vs  $R_{SET}$ ” graph one can see that 550 k $\Omega$  gives a vertical pulse width of about 180  $\mu\text{s}$ , the total time for the vertical sync period of NTSC (3 horizontal lines). A 550 k $\Omega$  will set the internal oscillator to a frequency such that eight cycles gives a time of 180  $\mu\text{s}$ , just long enough to prevent a double vertical sync pulse at the vertical sync output of the LM1881.

The LM1881 also generates a default vertical sync pulse when the vertical sync period is unusually long and has no serration pulses. With a very long vertical sync time the integrator has time to charge its internal capacitor above the voltage level  $V_2$ . Since there is no falling edge at the end of a serration pulse to clock the “D” flip-flop, the only high signal going to the OR gate is from the default comparator when output of the integrator reaches  $V_2$ . At this time the R/S flip-flop is toggled by the default comparator, starting the vertical sync pulse at pin 3 of the LM1881. If the default vertical sync period ends before the end of the input vertical sync period, then the falling edge of the vertical sync (positive pulse at the “D” flip-flop) will clock the high output from the comparator with  $V_1$  as a reference input. This will retrigger the oscillator, generating a second vertical sync output pulse. The “Vertical Default Sync Delay Time vs  $R_{SET}$ ” graph shows the relationship between the  $R_{SET}$  value and the delay time from the start of the vertical sync period before the default vertical sync pulse is generated. Using the NTSC example again the smallest resistor for  $R_{SET}$  is 500 k $\Omega$ . The vertical default time delay is about 50  $\mu\text{s}$ , much longer than the 30  $\mu\text{s}$  serration pulse spacing.

A common question is how can one calculate the required  $R_{SET}$  with a video timing standard that has no serration pulses during the vertical blanking. If the default vertical sync is to be used this is a very easy task. Use the “Vertical Default Sync Delay Time vs  $R_{SET}$ ” graph to select the necessary  $R_{SET}$  to give the desired delay time for the vertical sync output signal. If a second pulse is undesirable, then check the “Vertical Pulse Width vs  $R_{SET}$ ” graph to make sure the vertical output pulse will extend beyond the end of the input vertical sync period. In most systems the end of the vertical sync period may be very accurate. In this case the preferred design may be to start the vertical sync pulse at the end of the vertical sync period, similar to starting the vertical sync pulse after the first serration pulse. A VGA standard is to be used as an example to show how this is done. In this standard a horizontal line is 32  $\mu\text{s}$  long. The vertical sync period is two horizontal lines long, or 64  $\mu\text{s}$ . The vertical default sync delay time **must be longer** than the vertical sync period of 64  $\mu\text{s}$ . In this case  $R_{SET}$  must be larger than 680 k $\Omega$ .  $R_{SET}$  must still be small enough for the output of the integrator to reach  $V_1$  before the end of the vertical period of the input pulse. The first graph can be used to confirm that  $R_{SET}$  is small enough for the integrator. Instead of using the vertical serration pulse separation, use the actual pulse width of the vertical sync period, or 64  $\mu\text{s}$  in this example. This graph is linear, meaning that a value as large as 2.7 M $\Omega$  can be used for  $R_{SET}$  (twice the value as the maximum at 30  $\mu\text{s}$ ). Due to leakage currents it is advisable to keep the value of  $R_{SET}$  under 2.0 M $\Omega$ . In this example a value of 1.0 M $\Omega$  is selected, well above the minimum of 680 k $\Omega$ . With this value for  $R_{SET}$  the pulse width of the vertical sync output pulse of the LM1881 is about 340  $\mu\text{s}$ .

Feature Description (continued)

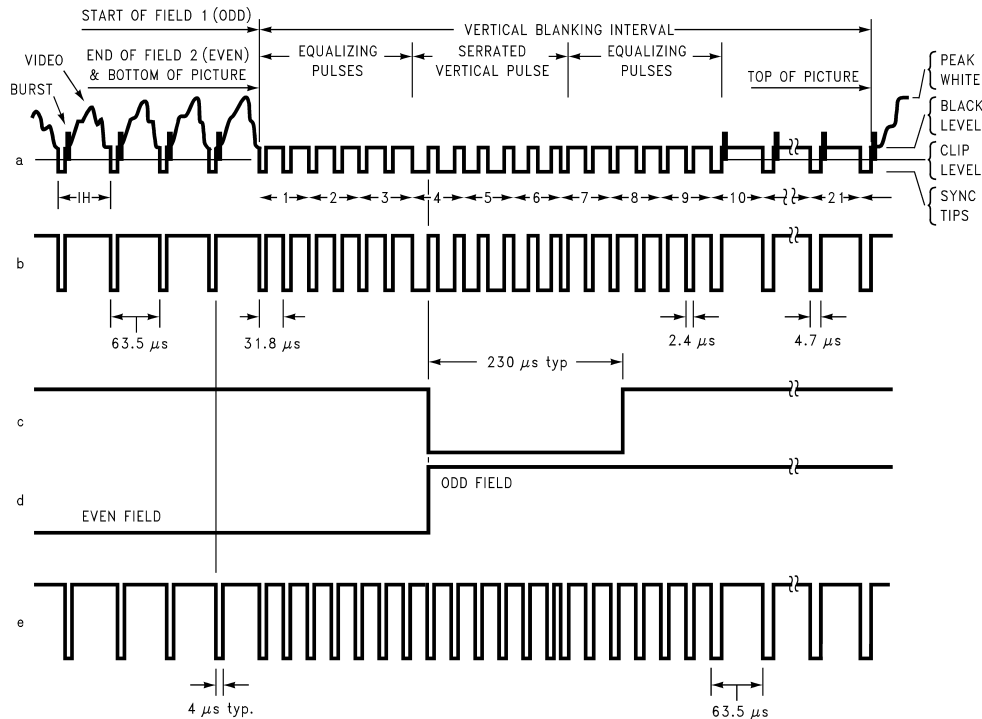

Figure 7. (a) Composite Video; (b) Composite Sync; (c) Vertical Output Pulse; (d) Odd and Even Field Index; (e) Burst Gate or Back Porch Clamp

7.3.3 Odd and Even Field Pulse

An unusual feature of LM1881 is an output level from Pin 7 that identifies the video field present at the input to the LM1881. This can be useful in frame memory storage applications or in extracting test signals that occur in alternate fields. For a composite video signal that is interlaced, one of the two fields that make up each video frame or picture must have a half horizontal scan line period at the end of the vertical scan—that is, at the bottom of the picture. This is called the “odd field” or “even field”. The “even field” or “field 2” has a complete horizontal scan line at the end of the field. An odd field starts on the leading edge of the first equalizing pulse, whereas the even field starts on the leading edge of the second equalizing pulse of the vertical retrace interval. Figure 7(a) shows the end of the even field and the start of the odd field.

To detect the odd and even fields the LM1881 again integrates the composite sync waveform (*Functional Block Diagram*). A capacitor is charged during the period between sync pulses and discharged when the sync pulse is present. The period between normal horizontal sync pulses is enough to allow the capacitor voltage to reach a threshold level of a comparator that clears a flip-flop which is also being clocked by the sync waveform. When the vertical interval is reached, the shorter integration time between equalizing pulses prevents this threshold from being reached and the Q output of the flip-flop is toggled with each equalizing pulse. Because the half-line period at the end of the odd field will have the same effect as an equalizing pulse period, the Q output will have a different polarity on successive fields. Thus by comparing the Q polarity with the vertical output pulse, an odd and even field index is generated. Pin 7 remains low during the even field and high during the odd field.

## Feature Description (continued)

### 7.3.4 Burst or Back Porch Output Pulse

In a composite video signal, the chroma burst is located on the back porch of the horizontal blanking period. This period, approximately 4.8  $\mu\text{s}$  long, is also the black level reference for the subsequent video scan line. The LM1881 generates a pulse at Pin 5 that can be used either to retrieve the chroma burst from the composite video signal (thus providing a subcarrier synchronizing signal) or as a clamp for the DC restoration of the video waveform. This output is obtained simply by charging an internal capacitor starting on the trailing edge of the horizontal sync pulses. Simultaneously the output of Pin 5 is pulled low and held until the capacitor charge circuit times out—4  $\mu\text{s}$  later. A shorter output burst gate pulse can be derived by differentiating the burst output using a series C-R network. This may be necessary in applications which require high horizontal scan rates in combination with normal (60 Hz–120 Hz) vertical scan rates.

## 7.4 Device Functional Modes

### 7.4.1 Operation Mode

In the normal operation mode, the LM1881 will extract video timing information and split the data up into the respective signals.

The LM1881 will output four sync signals including the composite sync, a vertical sync pulse, a burst gate or back porch clamp pulse, and an odd and even output.

The outputs from the LM1881 can be used to gen-lock video camera/VTR signals with graphics sources, provide identification of video fields for memory storage, recover suppressed or contaminated sync signals, and provide timing references for the extraction of coded or uncoded data on specific video scan lines.

## 8 Application and Implementation

### NOTE

Information in the following applications sections is not part of the TI component specification, and TI does not warrant its accuracy or completeness. TI's customers are responsible for determining suitability of components for their purposes. Customers should validate and test their design implementation to confirm system functionality.

### 8.1 Application Information

Apart from extracting a composite sync signal free of video information, the LM1881 outputs allow a number of interesting applications to be developed. As mentioned above, the burst gate or back porch clamp pulse allows DC restoration of the original video waveform for display or remodulation on an R.F. carrier, and retrieval of the color burst for color synchronization and decoding into R.G.B. components. For frame memory storage applications, the odd and even field lever allows identification of the appropriate field ensuring the correct read or write sequence. The vertical pulse output is particularly useful since it begins at a precise time—the rising edge of the first vertical serration in the sync waveform. This means that individual lines within the vertical blanking period (or anywhere in the active scan line period) can easily be extracted by counting the required number of transitions in the composite sync waveform following the start of the vertical output pulse.

The vertical blanking interval is proving popular as a means to transmit data which will not appear on a normal T.V. receiver screen. Data can be inserted beginning with line 10 (the first horizontal scan line on which the color burst appears) through to line 21. Usually lines 10 through 13 are not used which leaves lines 14 through 21 for inserting signals, which may be different from field to field. In the U.S., line 19 is normally reserved for a vertical interval reference signal (VIRS) and line 21 is reserved for closed caption data for the hearing impaired. The remaining lines are used in a number of ways. Lines 17 and 18 are frequently used during studio processing to add and delete vertical interval test signals (VITS) while lines 14 through 18 and line 20 can be used for Videotex/Teletext data. Several institutions are proposing to transmit financial data on line 17 and cable systems use the available lines in the vertical interval to send decoding data for descrambler terminals.

Because the vertical output pulse from the LM1881 coincides with the leading edge of the first vertical serration, sixteen positive or negative transitions later will be the start of line 14 in either field. At this point simple counters can be used to select the desired line(s) for insertion or deletion of data.

### 8.2 Typical Applications

#### 8.2.1 Video Line Selector

The circuit in [Figure 8](#) puts out a single video line according to the binary coded information applied to line select bits b0–b7. A line is selected by adding two to the desired line number, converting to a binary equivalent and applying the result to the line select inputs. The falling edge of the LM1881's vertical pulse is used to load the appropriate number into the counters (MM74C193N) and to set a start count latch using two NAND gates. Composite sync transitions are counted using the borrow out of the desired number of counters. The final borrow out pulse is used to turn on the analog switch (CD4066BC) during the desired line. The falling edge of this signal also resets the start count latch, thereby terminating the counting.

The circuit, as shown, will provide a single line output for each field in an interlaced video system (television) or a single line output in each frame for a non-interlaced video system (computer monitor). When a particular line in only one field of an interlaced video signal is desired, the odd and even field index output must be used instead of the vertical output pulse (invert the field index output to select the odd field). A single counter is needed for selecting lines 3 to 14; two counters are needed for selecting lines 15 to 253; and three counters will work for up to 2046 lines. An output buffer is required to drive low impedance loads.

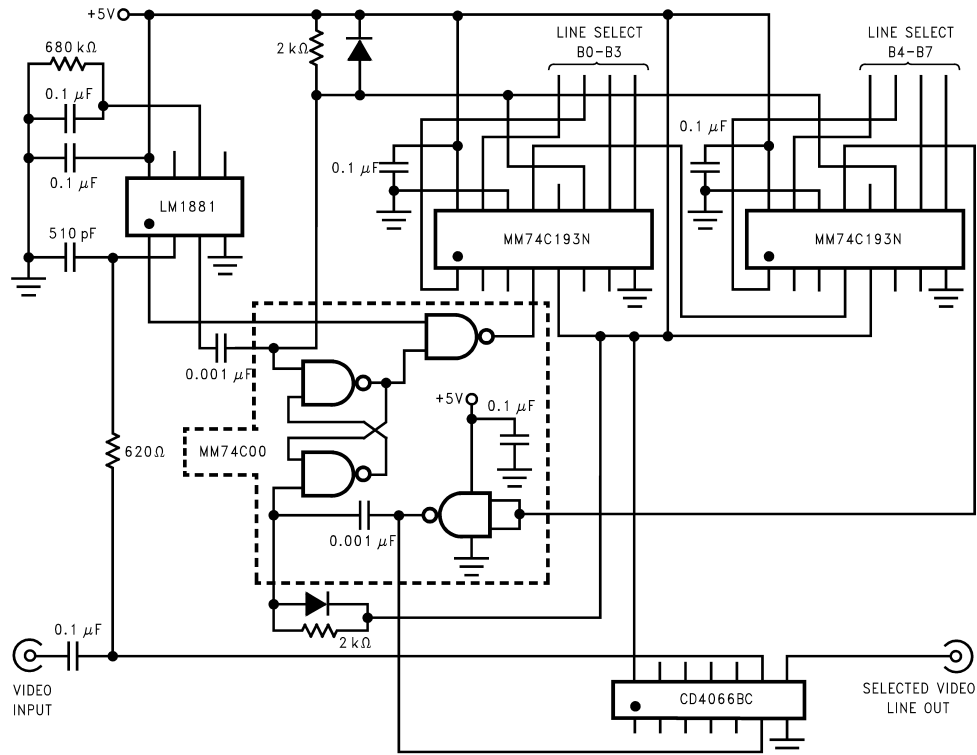
**Typical Applications (continued)**

**Figure 8. Video Line Selector**
**8.2.1.1 Design Requirements**

The design must have a single line output in an interlaced video system.

The use case can be used for televisions or computer monitors.

**8.2.1.2 Detailed Design Procedure**

For the composite input pin, a 510-pF capacitor and 620- $\Omega$  resistor are selected to create a lowpass filter for 500 kHz.

For Rset, a 680-k $\Omega$  was selected to allow for the Vertical Default Sync Delay Time to be set for 64  $\mu$ s. Please refer to [Figure 2](#) for Rset value selection.

## Typical Applications (continued)

### 8.2.2 Multiple Contiguous Video Line Selector With Black Level Restoration

The circuit in Figure 9 will select a number of adjoining lines starting with the line selected as in the previous example. Additional counters can be added as described previously for either higher starting line numbers or an increased number of contiguous output lines. The back porch pulse output of the LM1881 is used to gate the video input's black level through a lowpass filter (10-k $\Omega$ , 10- $\mu$ F) providing black level restoration at the video output when the output selected line(s) is not being gated through.

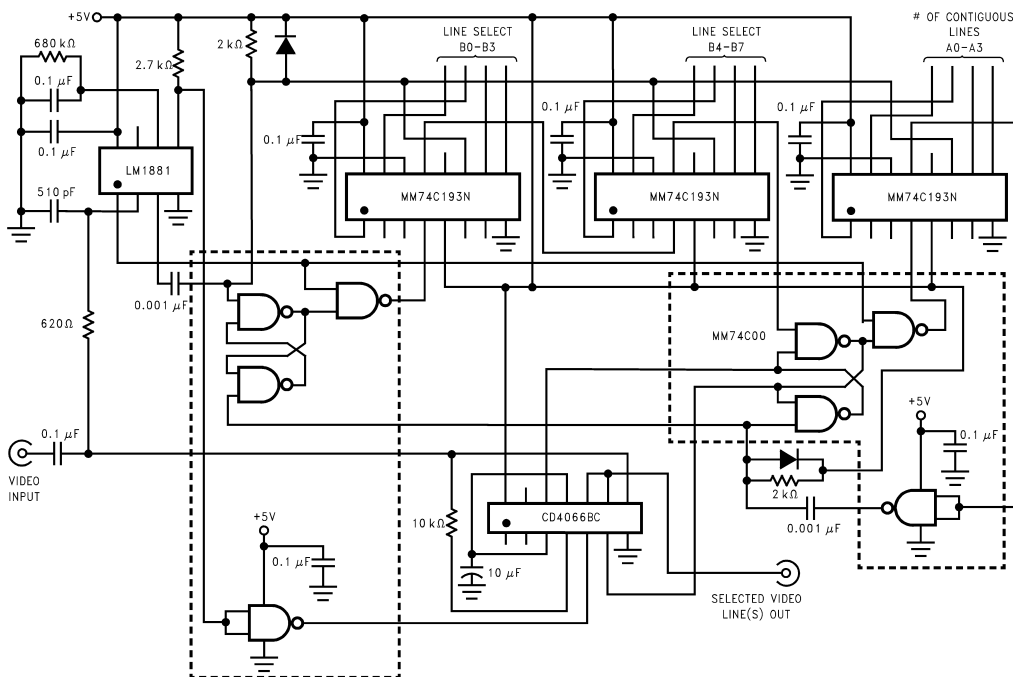

Figure 9. Multiple Contiguous Video Line Selector With Black Level Restoration

#### 8.2.2.1 Design Requirements

The design will select a number of adjoining lines starting with the line selected in the previous application example.

#### 8.2.2.2 Detailed Design Procedure

Another MM74C193N counter is added to the design to support the additional line outputs.

A 10-k $\Omega$  resistor and 10- $\mu$ F capacitor is added to the output of the BURST/BLACK Porch pin to create a low pass filter which adds in black level restoration to the video.

For the composite input pin, a 510-pF capacitor and 620- $\Omega$  resistor are selected to create a lowpass filter for 500 kHz.

For Rset, a 680-k $\Omega$  was selected to allow for the Vertical Default Sync Delay Time to be set for 64  $\mu$ S. Please refer to Figure 2 for Rset value selection.

## 9 Power Supply Recommendations

The LM1881 is designed to operate from an input voltage supply range between 5 VDC and 12 VDC.

The LM1881 requires external a decoupling capacitor at Pin 8 and another at Pin 6.

## 10 Device and Documentation Support

### 10.1 Community Resources

The following links connect to TI community resources. Linked contents are provided "AS IS" by the respective contributors. They do not constitute TI specifications and do not necessarily reflect TI's views; see TI's [Terms of Use](#).

**TI E2E™ Online Community** *TI's Engineer-to-Engineer (E2E) Community*. Created to foster collaboration among engineers. At [e2e.ti.com](http://e2e.ti.com), you can ask questions, share knowledge, explore ideas and help solve problems with fellow engineers.

**Design Support** *TI's Design Support* Quickly find helpful E2E forums along with design support tools and contact information for technical support.

### 10.2 Trademarks

E2E is a trademark of Texas Instruments.  
All other trademarks are the property of their respective owners.

### 10.3 Electrostatic Discharge Caution



These devices have limited built-in ESD protection. The leads should be shorted together or the device placed in conductive foam during storage or handling to prevent electrostatic damage to the MOS gates.

### 10.4 Glossary



[SLYZ022](#) — *TI Glossary*.

This glossary lists and explains terms, acronyms, and definitions.

## 11 Mechanical, Packaging, and Orderable Information

The following pages include mechanical, packaging, and orderable information. This information is the most current data available for the designated devices. This data is subject to change without notice and revision of this document. For browser-based versions of this data sheet, refer to the left-hand navigation.

**PACKAGING INFORMATION**

Orderable Device	Status (1)	Package Type	Package Drawing	Pins	Package Qty	Eco Plan (2)	Lead finish/ Ball material (6)	MSL Peak Temp (3)	Op Temp (°C)	Device Marking (4/5)	Samples
LM1881M/NOPB	ACTIVE	SOIC	D	8	95	RoHS & Green	SN	Level-1-260C-UNLIM	0 to 70	LM 1881M	
LM1881MX/NOPB	ACTIVE	SOIC	D	8	2500	RoHS & Green	SN	Level-1-260C-UNLIM	0 to 70	LM 1881M	
LM1881N/NOPB	OBSOLETE	PDIP	P	8		TBD	Call TI	Call TI		LM1881N	

(1) The marketing status values are defined as follows:

**ACTIVE:** Product device recommended for new designs.

**LIFEBUY:** TI has announced that the device will be discontinued, and a lifetime-buy period is in effect.

**NRND:** Not recommended for new designs. Device is in production to support existing customers, but TI does not recommend using this part in a new design.

**PREVIEW:** Device has been announced but is not in production. Samples may or may not be available.

**OBSOLETE:** TI has discontinued the production of the device.

(2) **RoHS:** TI defines "RoHS" to mean semiconductor products that are compliant with the current EU RoHS requirements for all 10 RoHS substances, including the requirement that RoHS substance do not exceed 0.1% by weight in homogeneous materials. Where designed to be soldered at high temperatures, "RoHS" products are suitable for use in specified lead-free processes. TI may reference these types of products as "Pb-Free".

**RoHS Exempt:** TI defines "RoHS Exempt" to mean products that contain lead but are compliant with EU RoHS pursuant to a specific EU RoHS exemption.

**Green:** TI defines "Green" to mean the content of Chlorine (Cl) and Bromine (Br) based flame retardants meet JS709B low halogen requirements of <=1000ppm threshold. Antimony trioxide based flame retardants must also meet the <=1000ppm threshold requirement.

(3) MSL, Peak Temp. - The Moisture Sensitivity Level rating according to the JEDEC industry standard classifications, and peak solder temperature.

(4) There may be additional marking, which relates to the logo, the lot trace code information, or the environmental category on the device.

(5) Multiple Device Markings will be inside parentheses. Only one Device Marking contained in parentheses and separated by a "-" will appear on a device. If a line is indented then it is a continuation of the previous line and the two combined represent the entire Device Marking for that device.

(6) Lead finish/Ball material - Orderable Devices may have multiple material finish options. Finish options are separated by a vertical ruled line. Lead finish/Ball material values may wrap to two lines if the finish value exceeds the maximum column width.

**Important Information and Disclaimer:**The information provided on this page represents TI's knowledge and belief as of the date that it is provided. TI bases its knowledge and belief on information provided by third parties, and makes no representation or warranty as to the accuracy of such information. Efforts are underway to better integrate information from third parties. TI has taken and continues to take reasonable steps to provide representative and accurate information but may not have conducted destructive testing or chemical analysis on incoming materials and chemicals. TI and TI suppliers consider certain information to be proprietary, and thus CAS numbers and other limited information may not be available for release.

In no event shall TI's liability arising out of such information exceed the total purchase price of the TI part(s) at issue in this document sold by TI to Customer on an annual basis.

**TAPE AND REEL INFORMATION**

**QUADRANT ASSIGNMENTS FOR PIN 1 ORIENTATION IN TAPE**



\*All dimensions are nominal

Device	Package Type	Package Drawing	Pins	SPQ	Reel Diameter (mm)	Reel Width W1 (mm)	A0 (mm)	B0 (mm)	K0 (mm)	P1 (mm)	W (mm)	Pin1 Quadrant
LM1881MX/NOPB	SOIC	D	8	2500	330.0	12.4	6.5	5.4	2.0	8.0	12.0	Q1

**TAPE AND REEL BOX DIMENSIONS**

\*All dimensions are nominal

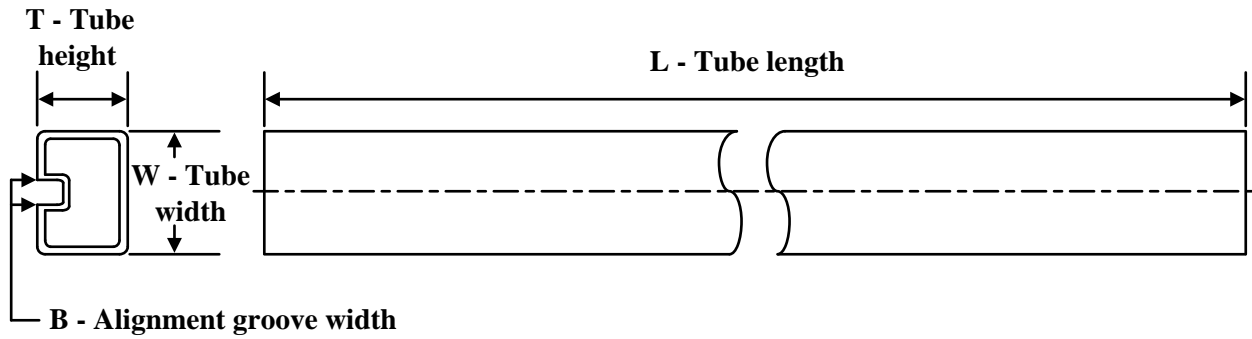
Device	Package Type	Package Drawing	Pins	SPQ	Length (mm)	Width (mm)	Height (mm)
LM1881MX/NOPB	SOIC	D	8	2500	367.0	367.0	35.0

**TUBE**

\*All dimensions are nominal

Device	Package Name	Package Type	Pins	SPQ	L (mm)	W (mm)	T (μm)	B (mm)
LM1881M/NOPB	D	SOIC	8	95	495	8	4064	3.05



D0008A

# PACKAGE OUTLINE

SOIC - 1.75 mm max height

SMALL OUTLINE INTEGRATED CIRCUIT



4214825/C 02/2019

## NOTES:

- Linear dimensions are in inches [millimeters]. Dimensions in parenthesis are for reference only. Controlling dimensions are in inches. Dimensioning and tolerancing per ASME Y14.5M.
- This drawing is subject to change without notice.
- This dimension does not include mold flash, protrusions, or gate burrs. Mold flash, protrusions, or gate burrs shall not exceed  $.006$  [0.15] per side.
- This dimension does not include interlead flash.
- Reference JEDEC registration MS-012, variation AA.

# EXAMPLE BOARD LAYOUT

D0008A

SOIC - 1.75 mm max height

SMALL OUTLINE INTEGRATED CIRCUIT



LAND PATTERN EXAMPLE  
 EXPOSED METAL SHOWN  
 SCALE:8X



SOLDER MASK DETAILS

4214825/C 02/2019

NOTES: (continued)

- 6. Publication IPC-7351 may have alternate designs.
- 7. Solder mask tolerances between and around signal pads can vary based on board fabrication site.

# EXAMPLE STENCIL DESIGN

D0008A

SOIC - 1.75 mm max height

SMALL OUTLINE INTEGRATED CIRCUIT



SOLDER PASTE EXAMPLE  
BASED ON .005 INCH [0.125 MM] THICK STENCIL  
SCALE:8X

4214825/C 02/2019

NOTES: (continued)

8. Laser cutting apertures with trapezoidal walls and rounded corners may offer better paste release. IPC-7525 may have alternate design recommendations.
9. Board assembly site may have different recommendations for stencil design.

P (R-PDIP-T8)

PLASTIC DUAL-IN-LINE PACKAGE



- NOTES:
- A. All linear dimensions are in inches (millimeters).
  - B. This drawing is subject to change without notice.
  - C. Falls within JEDEC MS-001 variation BA.

## IMPORTANT NOTICE AND DISCLAIMER

TI PROVIDES TECHNICAL AND RELIABILITY DATA (INCLUDING DATA SHEETS), DESIGN RESOURCES (INCLUDING REFERENCE DESIGNS), APPLICATION OR OTHER DESIGN ADVICE, WEB TOOLS, SAFETY INFORMATION, AND OTHER RESOURCES "AS IS" AND WITH ALL FAULTS, AND DISCLAIMS ALL WARRANTIES, EXPRESS AND IMPLIED, INCLUDING WITHOUT LIMITATION ANY IMPLIED WARRANTIES OF MERCHANTABILITY, FITNESS FOR A PARTICULAR PURPOSE OR NON-INFRINGEMENT OF THIRD PARTY INTELLECTUAL PROPERTY RIGHTS.

These resources are intended for skilled developers designing with TI products. You are solely responsible for (1) selecting the appropriate TI products for your application, (2) designing, validating and testing your application, and (3) ensuring your application meets applicable standards, and any other safety, security, regulatory or other requirements.

These resources are subject to change without notice. TI grants you permission to use these resources only for development of an application that uses the TI products described in the resource. Other reproduction and display of these resources is prohibited. No license is granted to any other TI intellectual property right or to any third party intellectual property right. TI disclaims responsibility for, and you will fully indemnify TI and its representatives against, any claims, damages, costs, losses, and liabilities arising out of your use of these resources.

TI's products are provided subject to [TI's Terms of Sale](#) or other applicable terms available either on [ti.com](https://www.ti.com) or provided in conjunction with such TI products. TI's provision of these resources does not expand or otherwise alter TI's applicable warranties or warranty disclaimers for TI products.

TI objects to and rejects any additional or different terms you may have proposed.

Mailing Address: Texas Instruments, Post Office Box 655303, Dallas, Texas 75265  
Copyright © 2023, Texas Instruments Incorporated

## Looking for pricing, stock, or lifecycle information?

Click below to explore more details on WIN SOURCE:

 [View LM1881M on WIN SOURCE](#)

 [Texas Instruments](#) Information

## Optimize Your Supply Chain with WIN SOURCE Solutions

-  Global Sourcing Solution
-  Obsolete Management
-  Cost Control Management
-  Shortage Management
-  Alternative Solution
-  Excess Inventory Management