

Dual Photovoltaic MOSFET Driver Solid-State Relay

DIP

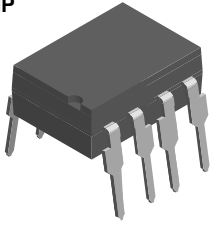

SMD

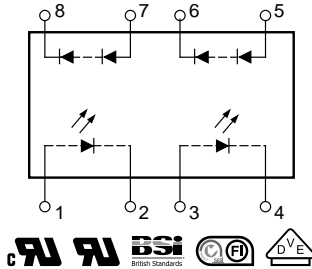
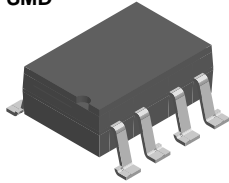

FEATURES

- High open circuit voltage
- High short circuit current
- Isolation test voltage 5300 V_{RMS}
- Logic compatible input
- High reliability
- Material categorization: for definitions of compliance please see www.vishay.com/doc?99912

RoHS
COMPLIANT

APPLICATIONS

- High-side driver
- Solid-state relays
- Floating power supply
- Power control
- Data acquisition
- ATE
- Isolated switching

AGENCY APPROVALS

- [UL1577](#)
- [DIN EN](#)
- [BSI](#)
- [CQC](#)
- [FIMKO](#)

DESIGN SUPPORT TOOLS

[click logo to get started](#)
3D
Models
Available

 Related
Documents

DESCRIPTION

The LH1262CB, LH1262CAC photovoltaic MOSFET driver consists of two LEDs optically coupled to two photodiode arrays. The photodiode array provides a floating source with adequate voltage and current to drive high-power MOSFET transistors. Optical coupling provides a high I/O isolation voltage. In order to turn the MOSFET off, an external resistance (gate-to-source) is required for gate discharge.

ORDERING INFORMATION

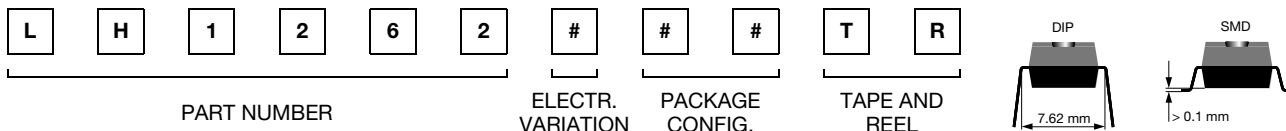

| PACKAGE | UL, VDE, BSI, CQC, FIMKO |
|----------------------|--------------------------|
| SMD-8 | LH1262CAC |
| SMD-8, tape and reel | LH1262CACTR |
| DIP-8 | LH1262CB |

ABSOLUTE MAXIMUM RATINGS (T_{amb} = 25 °C, unless otherwise specified)

| PARAMETER | TEST CONDITION | SYMBOL | VALUE | UNIT |
|--|------------------------|------------------|-------------|------|
| SSR | | | | |
| LED input ratings continuous forward current | | I _F | 50 | mA |
| LED input ratings reverse voltage | I _R ≤ 10 μA | V _R | 5.0 | V |
| Ambient operating temperature range | | T _{amb} | -40 to +85 | °C |
| Storage temperature range | | T _{stg} | -40 to +150 | °C |
| Pin soldering time | t = 7.0 s max. | T _s | 270 | °C |

Note

- Stresses in excess of the absolute maximum ratings can cause permanent damage to the device. Functional operation of the device is not implied at these or any other conditions in excess of those given in the operational sections of this document. Exposure to absolute maximum ratings for extended periods of the time can adversely affect reliability



| ELECTRICAL CHARACTERISTICS ($T_{amb} = 25\text{ }^{\circ}\text{C}$, unless otherwise specified) | | | | | | |
|--|--------------------------------|--------------|------|-------|------|---------------|
| PARAMETER | TEST CONDITION | SYMBOL | MIN. | TYP. | MAX. | UNIT |
| LED forward voltage | $I_F = 10\text{ mA}$ | V_F | 1.15 | 1.26 | 1.45 | V |
| Detector forward voltage | $I_F = 10\text{ }\mu\text{A}$ | $V_{F(PDA)}$ | - | 14 | - | V |
| Detector reverse voltage | $I_R = 2.0\text{ }\mu\text{A}$ | $V_{R(PDA)}$ | - | 200 | - | V |
| Open circuit voltage (pins 5, 6 or 7, 8) | $I_F = 5.0\text{ mA}$ | V_{OC} | 10 | 12.95 | 15 | V |
| | $I_F = 10\text{ mA}$ | V_{OC} | - | 13.45 | - | V |
| | $I_F = 20\text{ mA}$ | V_{OC} | - | 13.92 | - | V |
| Short circuit current (pins 5, 6 or 7, 8) | $I_F = 5.0\text{ mA}$ | I_{SC} | 1.0 | 1.6 | 6.5 | μA |
| | $I_F = 10\text{ mA}$ | I_{SC} | 2.6 | 3.4 | 14 | μA |
| | $I_F = 20\text{ mA}$ | I_{SC} | - | 6.9 | - | μA |

Note

- Minimum and maximum values are testing requirements. Typical values are characteristics of the device and are the result of engineering evaluations. Typical values are for information only and are not part of the testing requirements

| SWITCHING CHARACTERISTICS ($T_{amb} = 25\text{ }^{\circ}\text{C}$, unless otherwise specified) | | | | | | |
|---|-------------------------------------|-----------|------|------|------|---------------|
| PARAMETER | TEST CONDITION | SYMBOL | MIN. | TYP. | MAX. | UNIT |
| Turn-on time | $I_F = 20\text{ mA}$ ⁽¹⁾ | t_{on} | - | 35 | - | μs |
| Turn-off time | $I_F = 20\text{ mA}$ ⁽¹⁾ | t_{off} | - | 90 | - | μs |

Note

- ⁽¹⁾ $f = 1.0\text{ kHz}$, pulse width = $100\text{ }\mu\text{s}$, load (R_L) = $1.0\text{ M}\Omega$, 15 pF ; measured at 90 % rated voltage (t_{on}), 10 % rated voltage (t_{off}). Actuation speed depends upon the external t_{on} and t_{off} circuitry and the capacitance of the MOSFET

| SAFETY AND INSULATION RATINGS | | | | |
|--|---|------------|----------------|--------------------|
| PARAMETER | TEST CONDITION | SYMBOL | VALUE | UNIT |
| Climatic classification | According to IEC 68 part 1 | | 40 / 85 / 21 | |
| Pollution degree | According to DIN VDE 0109 | | 2 | |
| Comparative tracking index | Insulation group IIIa | CTI | 175 | |
| Maximum rated withstanding isolation voltage | According to UL1577, $t = 1\text{ min}$ | V_{ISO} | 5300 | V_{RMS} |
| Tested withstanding isolation voltage | According to UL1577, $t = 1\text{ s}$ | V_{ISO} | 4420 | V_{RMS} |
| Maximum transient isolation voltage | According to DIN EN 60747-5-5 | V_{IOTM} | 8000 | V_{peak} |
| Maximum repetitive peak isolation voltage | According to DIN EN 60747-5-5 | V_{IORM} | 890 | V_{peak} |
| Isolation resistance | $V_{IO} = 500\text{ V}$, $T_{amb} = 25\text{ }^{\circ}\text{C}$ | R_{IO} | $\geq 10^{12}$ | Ω |
| | $V_{IO} = 500\text{ V}$, $T_{amb} = 100\text{ }^{\circ}\text{C}$ | R_{IO} | $\geq 10^{11}$ | Ω |
| | $V_{IO} = 500\text{ V}$, $T_{amb} = T_S$ | R_{IO} | $\geq 10^9$ | Ω |
| Output safety power | | P_{SO} | 700 | mW |
| Input safety current | | I_{SI} | 300 | mA |
| Safety temperature | | T_S | 175 | $^{\circ}\text{C}$ |
| Creepage distance (DIP) | DIP-8 | | ≥ 7 | mm |
| Clearance distance (DIP) | | | ≥ 7 | mm |
| Creepage distance (SMD) | SMD-8 | | ≥ 8 | mm |
| Clearance distance (SMD) | | | ≥ 8 | mm |
| Insulation thickness | | DTI | ≥ 0.4 | mm |

Note

- As per IEC 60747-5-5, § 7.4.3.8.2, this optocoupler is suitable for "safe electrical insulation" only within the safety ratings. Compliance with the safety ratings shall be ensured by means of protective circuits



FUNCTIONAL DESCRIPTION

Figure 1 outlines the IV characteristics of the illuminated photodiode array (PDA). For operation at voltages below V_{OC} , the PDA acts as a nearly constant current source. The actual region of operation depends upon the load.

The amount of current applied to the LED (pins 1 and 2 or 3 and 4) determines the amount of light produced for the PDA. For high temperature operation, more LED current may be required.

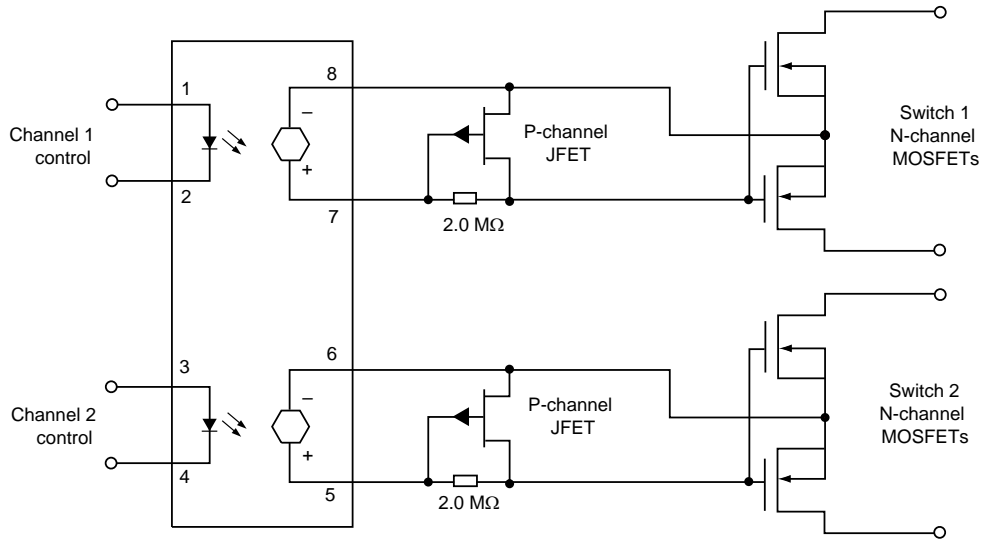

ih1262cb_08

Fig. 1 - Typical Dual Form A Solid-State Relay Application

PACKAGE DIMENSIONS (in millimeters)

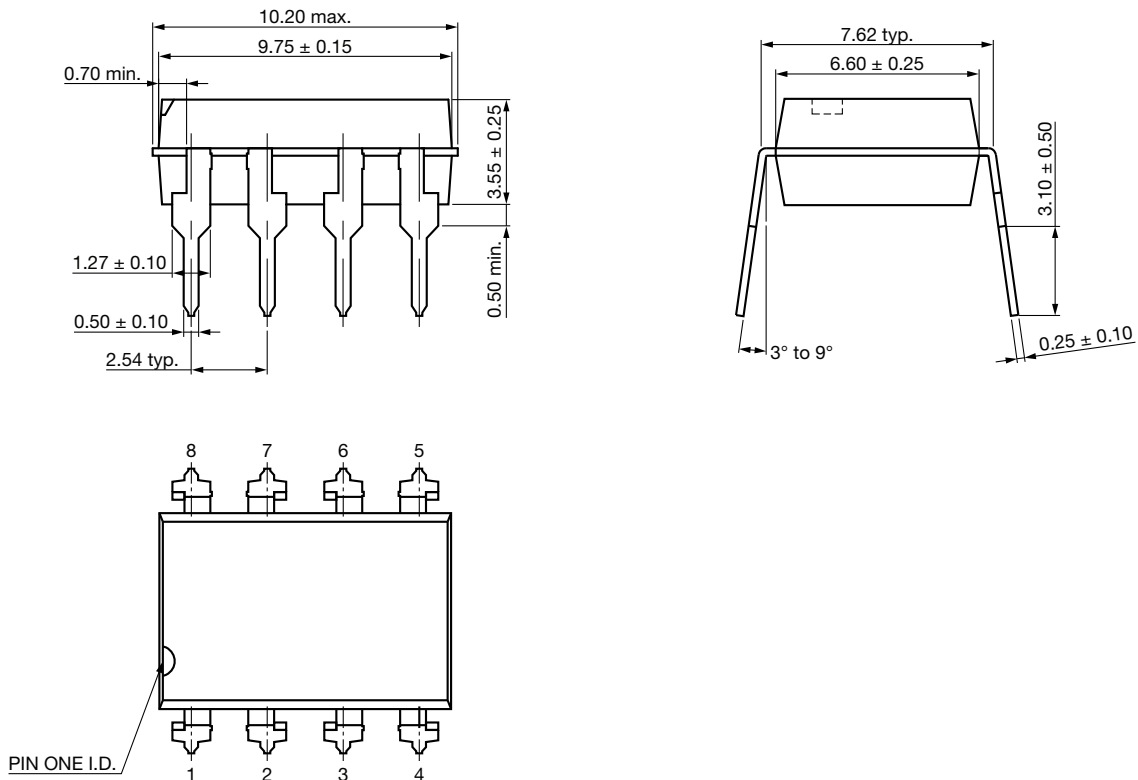

Fig. 2 - DIP-8 Package Drawing

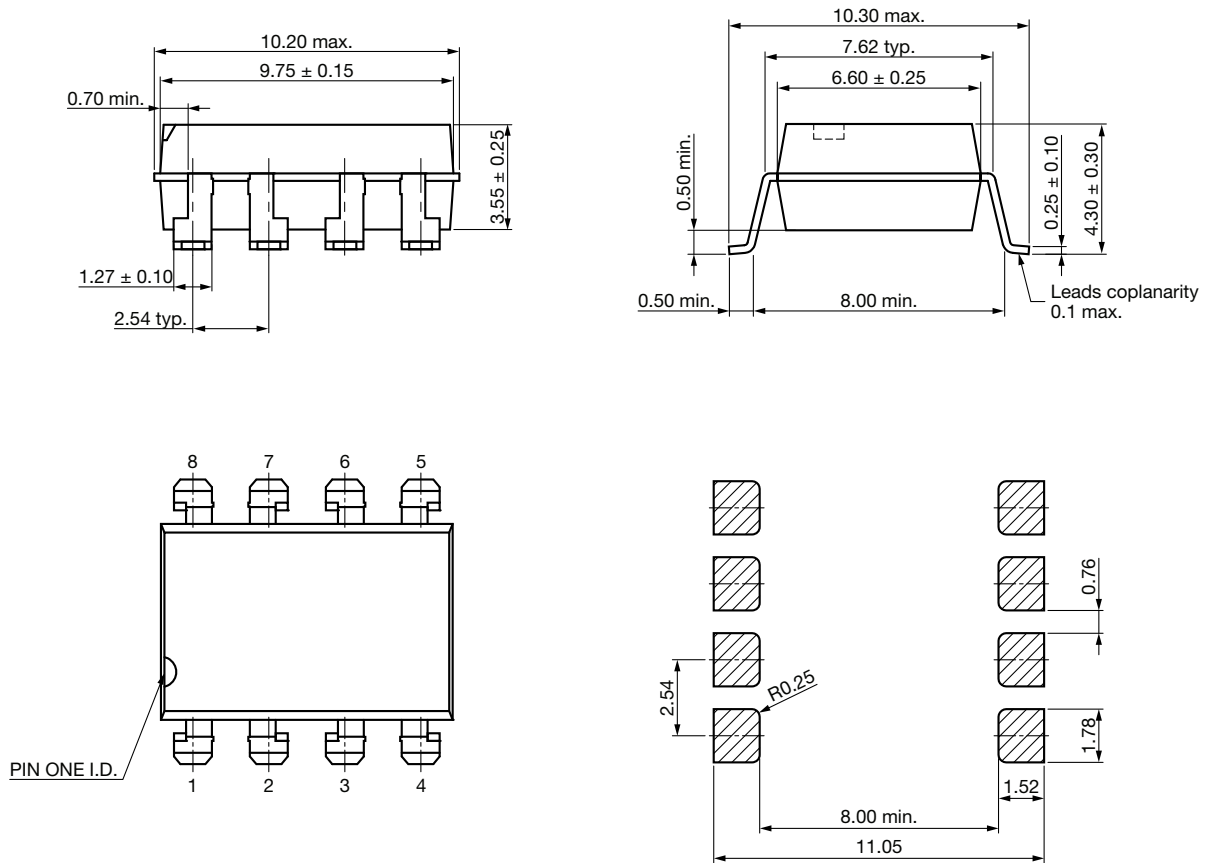

Fig. 3 - SMD-8 Package Drawing

PACKAGE MARKING (example)

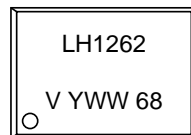

Fig. 4 - LH1262

Notes

- VDE logo is only marked on option 1 parts
- Tape and reel suffix (T) is not part of the package marking



SOLDER PROFILES

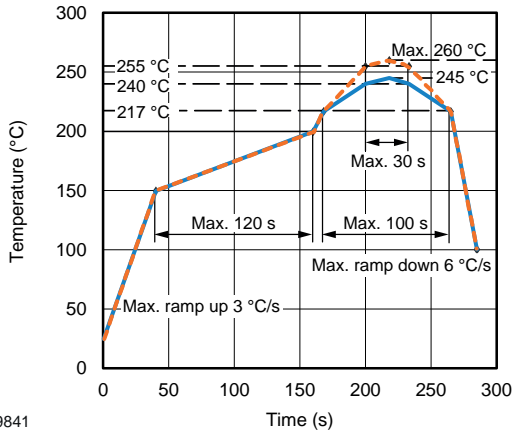

19841

Fig. 5 - Lead (Pb)-free Reflow Solder Profile According to J-STD-020 for SMD Devices

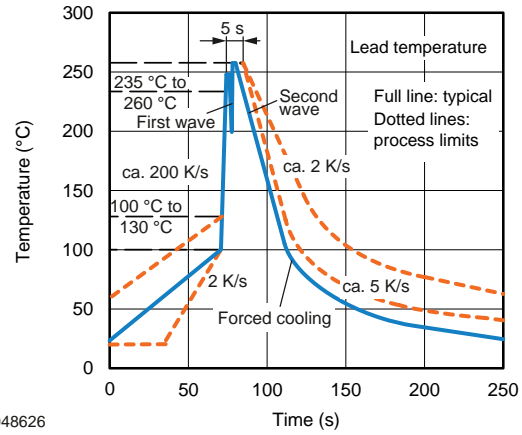

948626

Fig. 6 - Wave Soldering Double Wave Profile According to J-STD-020 for DIP Devices



Disclaimer

ALL PRODUCT, PRODUCT SPECIFICATIONS AND DATA ARE SUBJECT TO CHANGE WITHOUT NOTICE TO IMPROVE RELIABILITY, FUNCTION OR DESIGN OR OTHERWISE.

Vishay Intertechnology, Inc., its affiliates, agents, and employees, and all persons acting on its or their behalf (collectively, "Vishay"), disclaim any and all liability for any errors, inaccuracies or incompleteness contained in any datasheet or in any other disclosure relating to any product.

Vishay makes no warranty, representation or guarantee regarding the suitability of the products for any particular purpose or the continuing production of any product. To the maximum extent permitted by applicable law, Vishay disclaims (i) any and all liability arising out of the application or use of any product, (ii) any and all liability, including without limitation special, consequential or incidental damages, and (iii) any and all implied warranties, including warranties of fitness for particular purpose, non-infringement and merchantability.

Statements regarding the suitability of products for certain types of applications are based on Vishay's knowledge of typical requirements that are often placed on Vishay products in generic applications. Such statements are not binding statements about the suitability of products for a particular application. It is the customer's responsibility to validate that a particular product with the properties described in the product specification is suitable for use in a particular application. Parameters provided in datasheets and / or specifications may vary in different applications and performance may vary over time. All operating parameters, including typical parameters, must be validated for each customer application by the customer's technical experts. Product specifications do not expand or otherwise modify Vishay's terms and conditions of purchase, including but not limited to the warranty expressed therein.

Except as expressly indicated in writing, Vishay products are not designed for use in medical, life-saving, or life-sustaining applications or for any other application in which the failure of the Vishay product could result in personal injury or death. Customers using or selling Vishay products not expressly indicated for use in such applications do so at their own risk. Please contact authorized Vishay personnel to obtain written terms and conditions regarding products designed for such applications.

No license, express or implied, by estoppel or otherwise, to any intellectual property rights is granted by this document or by any conduct of Vishay. Product names and markings noted herein may be trademarks of their respective owners.

Looking for pricing, stock, or lifecycle information?

Click below to explore more details on WIN SOURCE:

 [View LH1262CAC on WIN SOURCE](#)

 [Vishay Information](#)

Optimize Your Supply Chain with WIN SOURCE Solutions

-  Global Sourcing Solution
-  Obsolete Management
-  Cost Control Management
-  Shortage Management
-  Alternative Solution
-  Excess Inventory Management