



# THE DATASHEET OF LF353N/NOPB



## LF353-N Wide Bandwidth Dual JFET Input Operational Amplifier

 Check for Samples: [LF353-N](#)

### FEATURES

- **Internally Trimmed Offset Voltage: 10 mV**
- **Low Input Bias Current: 50pA**
- **Low Input Noise Voltage: 25 nV/√Hz**
- **Low Input Noise Current: 0.01 pA/√Hz**
- **Wide Gain Bandwidth: 4 MHz**
- **High Slew Rate: 13 V/μs**
- **Low Supply Current: 3.6 mA**
- **High Input Impedance: 10<sup>12</sup>Ω**
- **Low Total Harmonic Distortion : ≤0.02%**
- **Low 1/f Noise Corner: 50 Hz**
- **Fast Settling Time to 0.01%: 2 μs**

### DESCRIPTION

These devices are low cost, high speed, dual JFET input operational amplifiers with an internally trimmed input offset voltage (BI-FET II technology). They require low supply current yet maintain a large gain bandwidth product and fast slew rate. In addition, well matched high voltage JFET input devices provide very low input bias and offset currents. The LF353-N is pin compatible with the standard LM1558 allowing designers to immediately upgrade the overall performance of existing LM1558 and LM358 designs.

These amplifiers may be used in applications such as high speed integrators, fast D/A converters, sample and hold circuits and many other circuits requiring low input offset voltage, low input bias current, high input impedance, high slew rate and wide bandwidth. The devices also exhibit low noise and offset voltage drift.

### Typical Connection

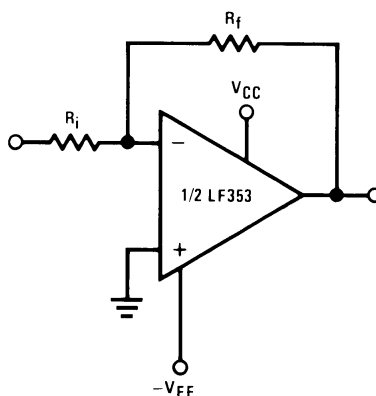

Please be aware that an important notice concerning availability, standard warranty, and use in critical applications of Texas Instruments semiconductor products and disclaimers thereto appears at the end of this data sheet.

All trademarks are the property of their respective owners.

**Simplified Schematic**

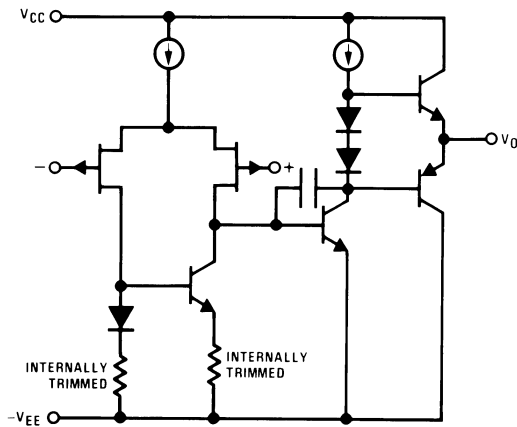

**Figure 1. 1/2 Dual**

**Dual-In-Line Package  
Top View**

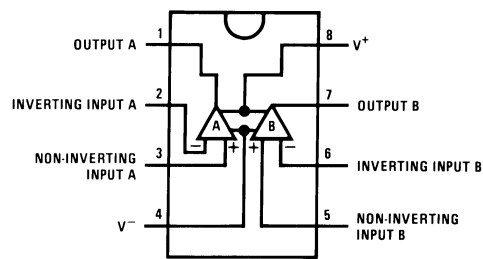

**Figure 2. 8-Pin SOIC (See D Package)  
8-Pin PDIP (See P Package)**



These devices have limited built-in ESD protection. The leads should be shorted together or the device placed in conductive foam during storage or handling to prevent electrostatic damage to the MOS gates.

### Absolute Maximum Ratings<sup>(1)(2)</sup>

Supply Voltage		±18V
Power Dissipation		See <sup>(3)</sup>
Operating Temperature Range		0°C to +70°C
T <sub>J</sub> (MAX)		150°C
Differential Input Voltage		±30V
Input Voltage Range <sup>(4)</sup>		±15V
Output Short Circuit Duration		Continuous
Storage Temperature Range		-65°C to +150°C
Lead Temp. (Soldering, 10 sec.)		260°C
Soldering Information: Dual-In-Line Package Soldering (10 sec.)		260°C
Small Outline Package	Vapor Phase (60 sec.)	215°C
	Infrared (15 sec.)	220°C
ESD Tolerance <sup>(5)</sup>		1000V
θ <sub>JA</sub> D Package		TBD

- (1) Absolute Maximum Ratings indicate limits beyond which damage to the device may occur. Operating ratings indicate conditions for which the device is functional, but do not ensure specific performance limits. Electrical Characteristics state DC and AC electrical specifications under particular test conditions which ensure specific performance limits. This assumes that the device is within the Operating Ratings. Specifications are not ensured for parameters where no limit is given, however, the typical value is a good indication of device performance.
- (2) If Military/Aerospace specified devices are required, please contact the Texas Instruments Sales Office/ Distributors for availability and specifications.
- (3) For operating at elevated temperatures, the device must be derated based on a thermal resistance of 115°C/W typ junction to ambient for the P package, and 160°C/W typ junction to ambient for the D package.
- (4) Unless otherwise specified the absolute maximum negative input voltage is equal to the negative power supply voltage.
- (5) Human body model, 1.5 kΩ in series with 100 pF.

## DC Electrical Characteristics

Symbol	Parameter	Conditions	LF353-N			Units
			Min	Typ	Max	
$V_{OS}$	Input Offset Voltage	$R_S=10k\Omega$ , $T_A=25^\circ\text{C}$ Over Temperature		5	10	mV
					13	mV
$\Delta V_{OS}/\Delta T$	Average TC of Input Offset Voltage	$R_S=10k\Omega$		10		$\mu\text{V}/^\circ\text{C}$
$I_{OS}$	Input Offset Current	$T_j=25^\circ\text{C}^{(1)(2)}$		25	100	pA
		$T_j\leq 70^\circ\text{C}$			4	nA
$I_B$	Input Bias Current	$T_j=25^\circ\text{C}^{(1)(2)}$		50	200	pA
		$T_j\leq 70^\circ\text{C}$			8	nA
$R_{IN}$	Input Resistance	$T_j=25^\circ\text{C}$		$10^{12}$		$\Omega$
$A_{VOL}$	Large Signal Voltage Gain	$V_S=\pm 15\text{V}$ , $T_A=25^\circ\text{C}$	25	100		V/mV
		$V_O=\pm 10\text{V}$ , $R_L=2k\Omega$				
		Over Temperature	15			V/mV
$V_O$	Output Voltage Swing	$V_S=\pm 15\text{V}$ , $R_L=10k\Omega$	$\pm 12$	$\pm 13.5$		V
$V_{CM}$	Input Common-Mode Voltage	$V_S=\pm 15\text{V}$	$\pm 11$	+15		V
	Range			-12		V
CMRR	Common-Mode Rejection Ratio	$R_S\leq 10k\Omega$	70	100		dB
PSRR	Supply Voltage Rejection Ratio	See <sup>(3)</sup>	70	100		dB
$I_S$	Supply Current			3.6	6.5	mA

- (1) These specifications apply for  $V_S=\pm 15\text{V}$  and  $0^\circ\text{C}\leq T_A\leq 70^\circ\text{C}$ .  $V_{OS}$ ,  $I_B$  and  $I_{OS}$  are measured at  $V_{CM}=0$ .
- (2) The input bias currents are junction leakage currents which approximately double for every  $10^\circ\text{C}$  increase in the junction temperature,  $T_j$ . Due to the limited production test time, the input bias currents measured are correlated to junction temperature. In normal operation the junction temperature rises above the ambient temperature as a result of internal power dissipation,  $P_D$ .  $T_j=T_A+\theta_{JA} P_D$  where  $\theta_{JA}$  is the thermal resistance from junction to ambient. Use of a heat sink is recommended if input bias current is to be kept to a minimum.
- (3) Supply voltage rejection ratio is measured for both supply magnitudes increasing or decreasing simultaneously in accordance with common practice.  $V_S = \pm 6\text{V}$  to  $\pm 15\text{V}$ .

## AC Electrical Characteristics<sup>(1)</sup>

Symbol	Parameter	Conditions	LF353-N			Units
			Min	Typ	Max	
	Amplifier to Amplifier Coupling	$T_A=25^\circ\text{C}$ , $f=1\text{ Hz}-20\text{ kHz}$ (Input Referred)		-120		dB
SR	Slew Rate	$V_S=\pm 15\text{V}$ , $T_A=25^\circ\text{C}$	8.0	13		V/ $\mu\text{s}$
GBW	Gain Bandwidth Product	$V_S=\pm 15\text{V}$ , $T_A=25^\circ\text{C}$	2.7	4		MHz
$e_n$	Equivalent Input Noise Voltage	$T_A=25^\circ\text{C}$ , $R_S=100\Omega$ , $f=1000\text{ Hz}$		16		nV/ $\sqrt{\text{Hz}}$
$i_n$	Equivalent Input Noise Current	$T_j=25^\circ\text{C}$ , $f=1000\text{ Hz}$		0.01		pA/ $\sqrt{\text{Hz}}$
THD	Total Harmonic Distortion	$A_V=+10$ , $R_L=10k$ , $V_O=20\text{Vp-p}$ , $BW=20\text{ Hz}-20\text{ kHz}$		<0.02		%

- (1) These specifications apply for  $V_S=\pm 15\text{V}$  and  $0^\circ\text{C}\leq T_A\leq 70^\circ\text{C}$ .  $V_{OS}$ ,  $I_B$  and  $I_{OS}$  are measured at  $V_{CM}=0$ .

Typical Performance Characteristics

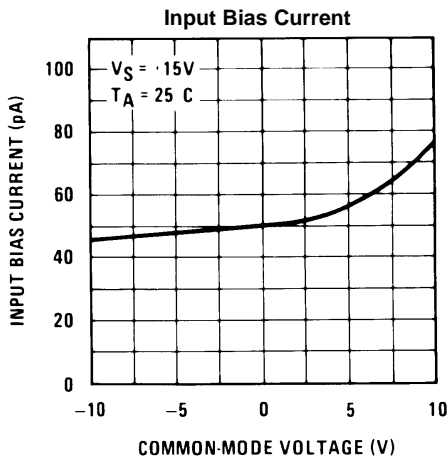

Figure 3.

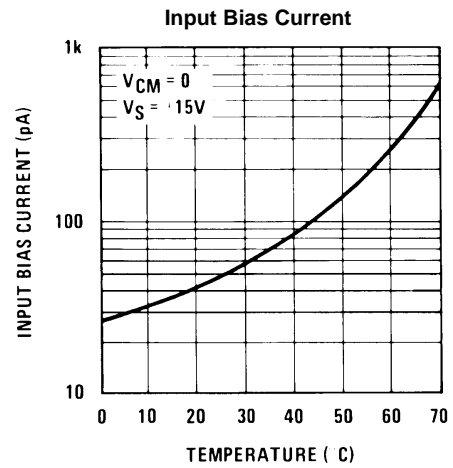

Figure 4.

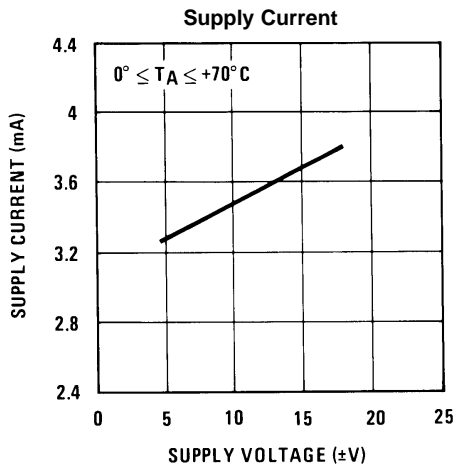

Figure 5.

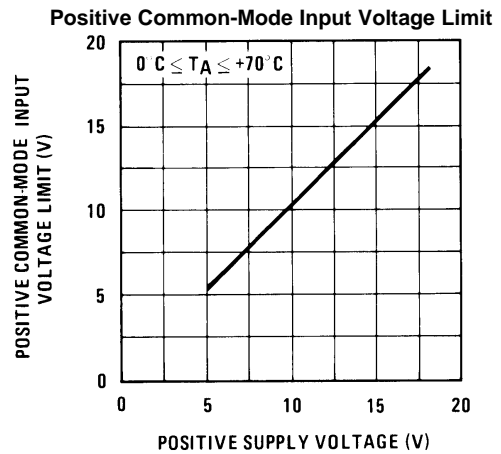

Figure 6.

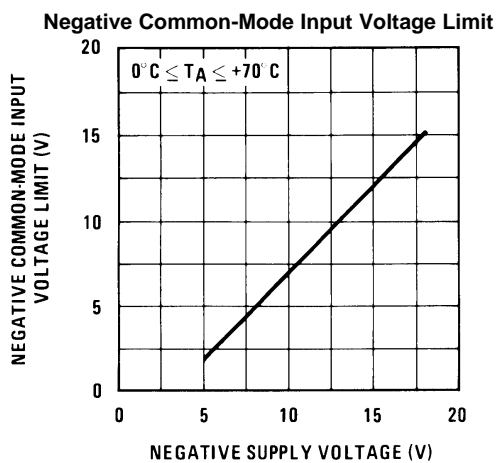

Figure 7.

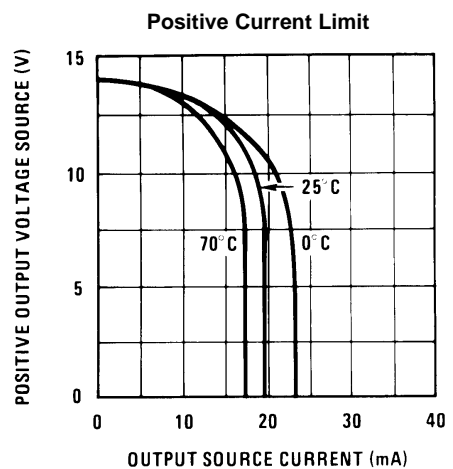

Figure 8.

**Typical Performance Characteristics (continued)**

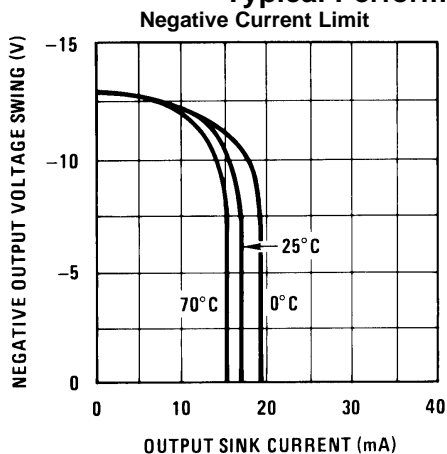

Figure 9.

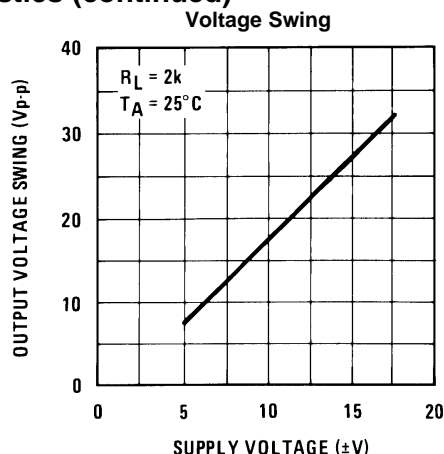

Figure 10.

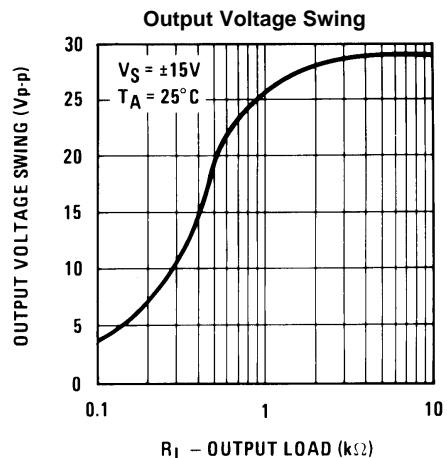

Figure 11.

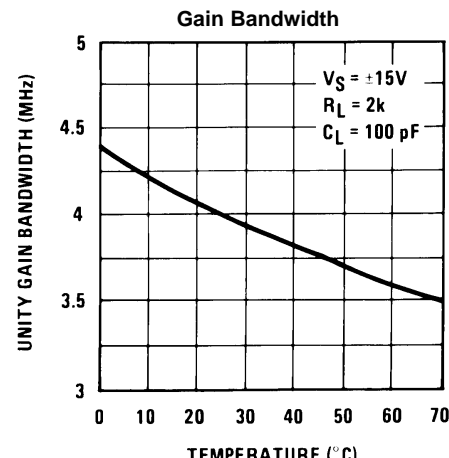

Figure 12.

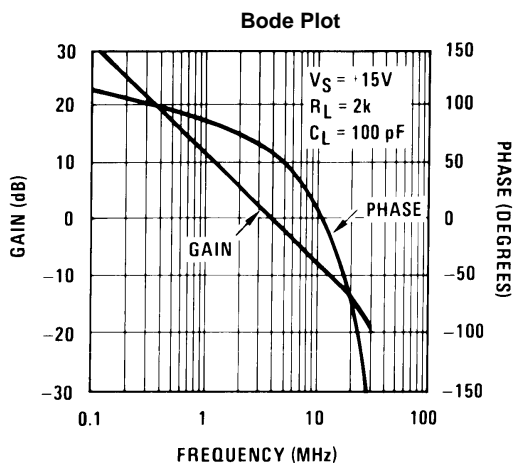

Figure 13.

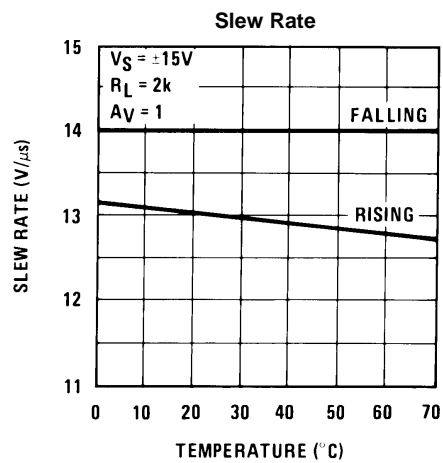

Figure 14.

Typical Performance Characteristics (continued)

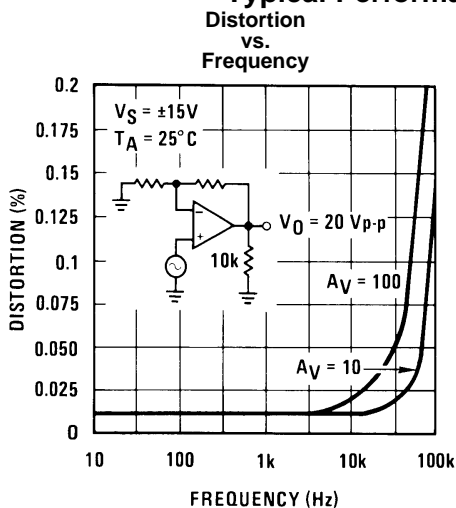

Figure 15.

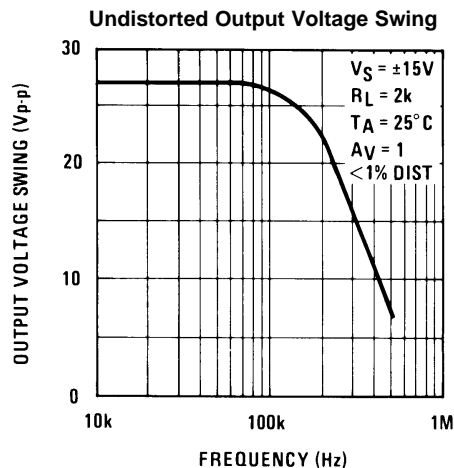

Figure 16.

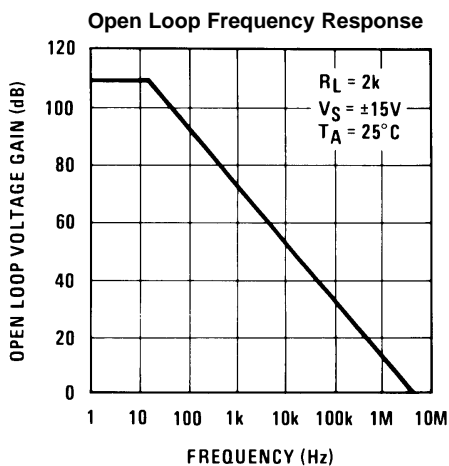

Figure 17.

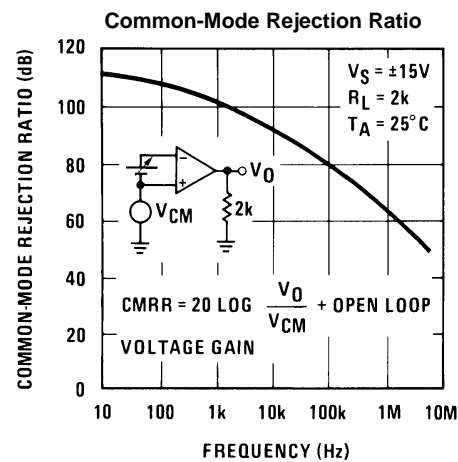

Figure 18.

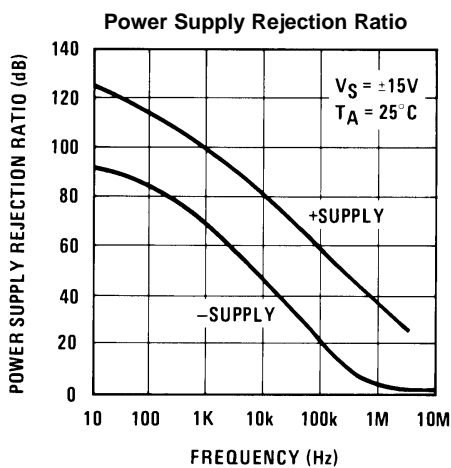

Figure 19.

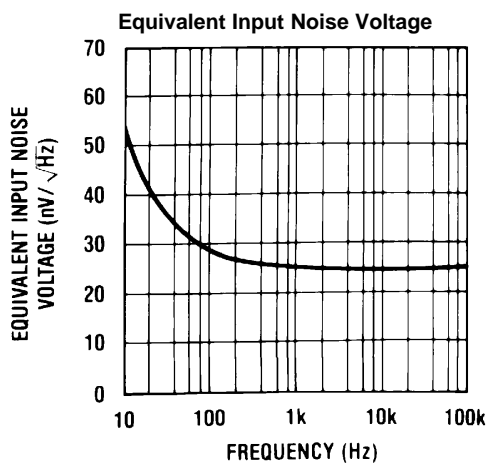

Figure 20.

**Typical Performance Characteristics (continued)**

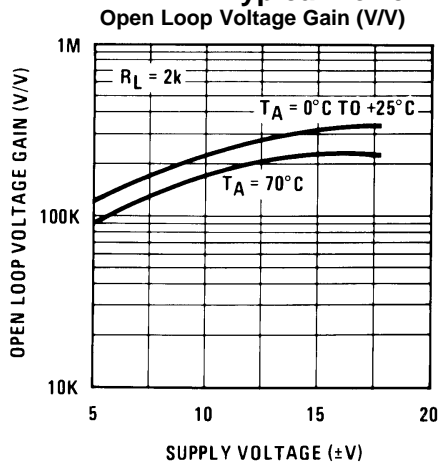

Figure 21.

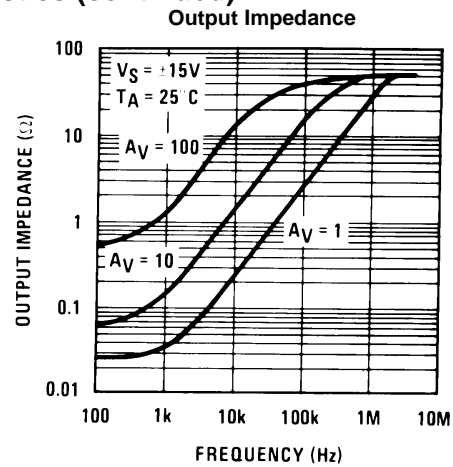

Figure 22.

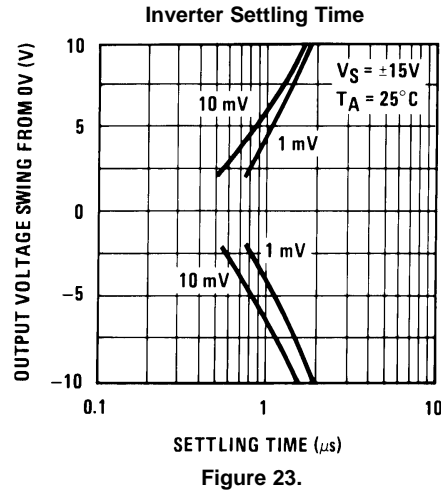

Figure 23.

Pulse Response

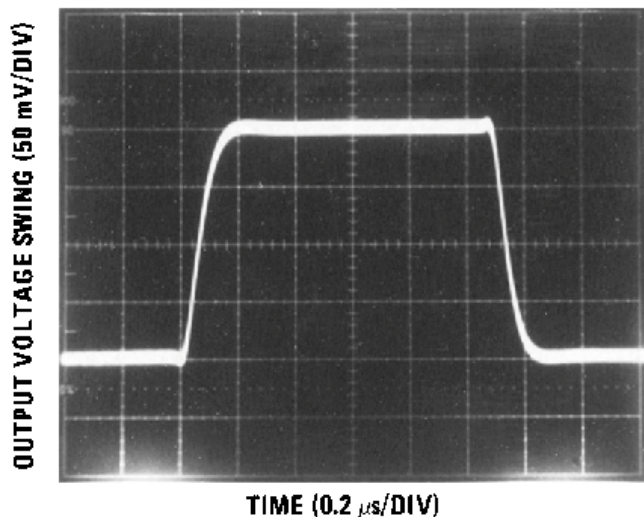

Figure 24. Small Signaling Inverting

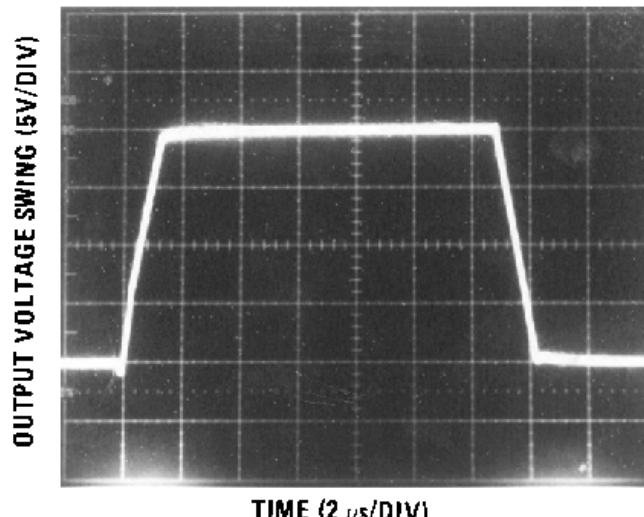

Figure 25. Large Signal Inverting

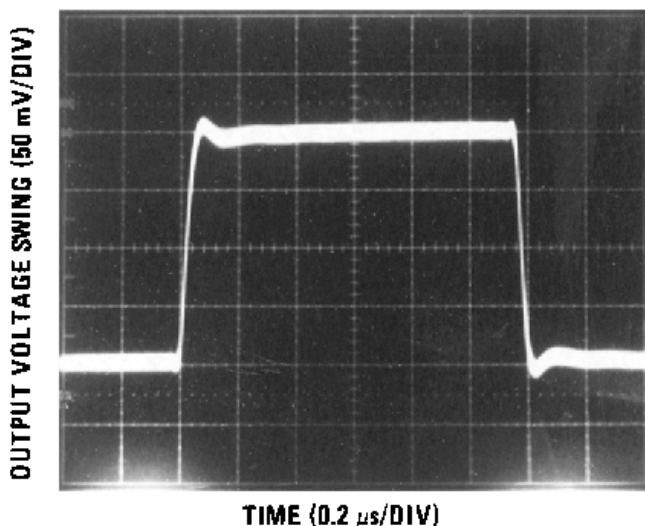

Figure 26. Small Signal Non-Inverting

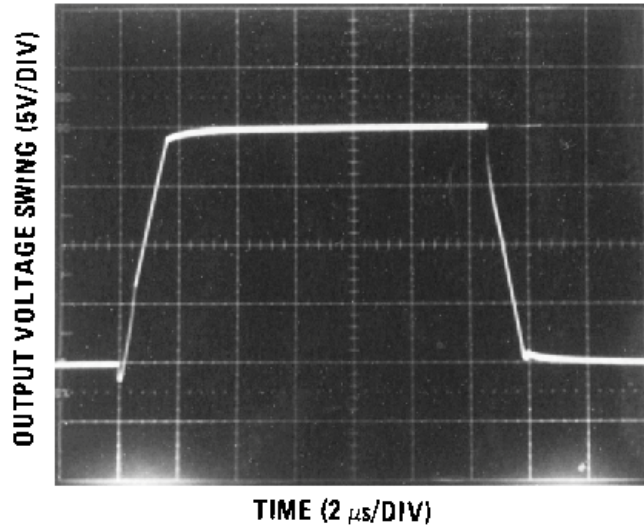
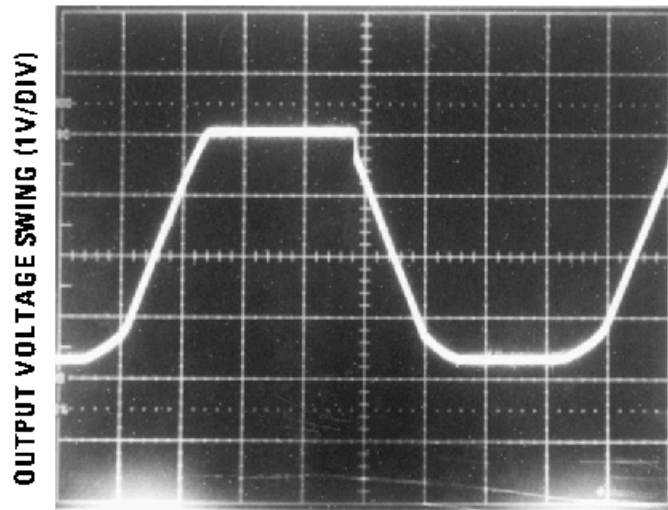

Figure 27. Large Signal Non-Inverting



TIME (5  $\mu$ s/DIV)

Figure 28. Current Limit ( $R_L = 100\Omega$ )

## APPLICATION HINTS

These devices are op amps with an internally trimmed input offset voltage and JFET input devices (BI-FET II). These JFETs have large reverse breakdown voltages from gate to source and drain eliminating the need for clamps across the inputs. Therefore, large differential input voltages can easily be accommodated without a large increase in input current. The maximum differential input voltage is independent of the supply voltages. However, neither of the input voltages should be allowed to exceed the negative supply as this will cause large currents to flow which can result in a destroyed unit.

Exceeding the negative common-mode limit on either input will force the output to a high state, potentially causing a reversal of phase to the output. Exceeding the negative common-mode limit on both inputs will force the amplifier output to a high state. In neither case does a latch occur since raising the input back within the common-mode range again puts the input stage and thus the amplifier in a normal operating mode.

Exceeding the positive common-mode limit on a single input will not change the phase of the output; however, if both inputs exceed the limit, the output of the amplifier will be forced to a high state.

The amplifiers will operate with a common-mode input voltage equal to the positive supply; however, the gain bandwidth and slew rate may be decreased in this condition. When the negative common-mode voltage swings to within 3V of the negative supply, an increase in input offset voltage may occur.

Each amplifier is individually biased by a zener reference which allows normal circuit operation on  $\pm 6V$  power supplies. Supply voltages less than these may result in lower gain bandwidth and slew rate.

The amplifiers will drive a 2 k $\Omega$  load resistance to  $\pm 10V$  over the full temperature range of 0°C to +70°C. If the amplifier is forced to drive heavier load currents, however, an increase in input offset voltage may occur on the negative voltage swing and finally reach an active current limit on both positive and negative swings.

Precautions should be taken to ensure that the power supply for the integrated circuit never becomes reversed in polarity or that the unit is not inadvertently installed backwards in a socket as an unlimited current surge through the resulting forward diode within the IC could cause fusing of the internal conductors and result in a destroyed unit.

As with most amplifiers, care should be taken with lead dress, component placement and supply decoupling in order to ensure stability. For example, resistors from the output to an input should be placed with the body close to the input to minimize “pick-up” and maximize the frequency of the feedback pole by minimizing the capacitance from the input to ground.

A feedback pole is created when the feedback around any amplifier is resistive. The parallel resistance and capacitance from the input of the device (usually the inverting input) to AC ground set the frequency of the pole. In many instances the frequency of this pole is much greater than the expected 3 dB frequency of the closed loop gain and consequently there is negligible effect on stability margin. However, if the feedback pole is less than approximately 6 times the expected 3 dB frequency a lead capacitor should be placed from the output to the input of the op amp. The value of the added capacitor should be such that the RC time constant of this capacitor and the resistance it parallels is greater than or equal to the original feedback pole time constant.

Detailed Schematic

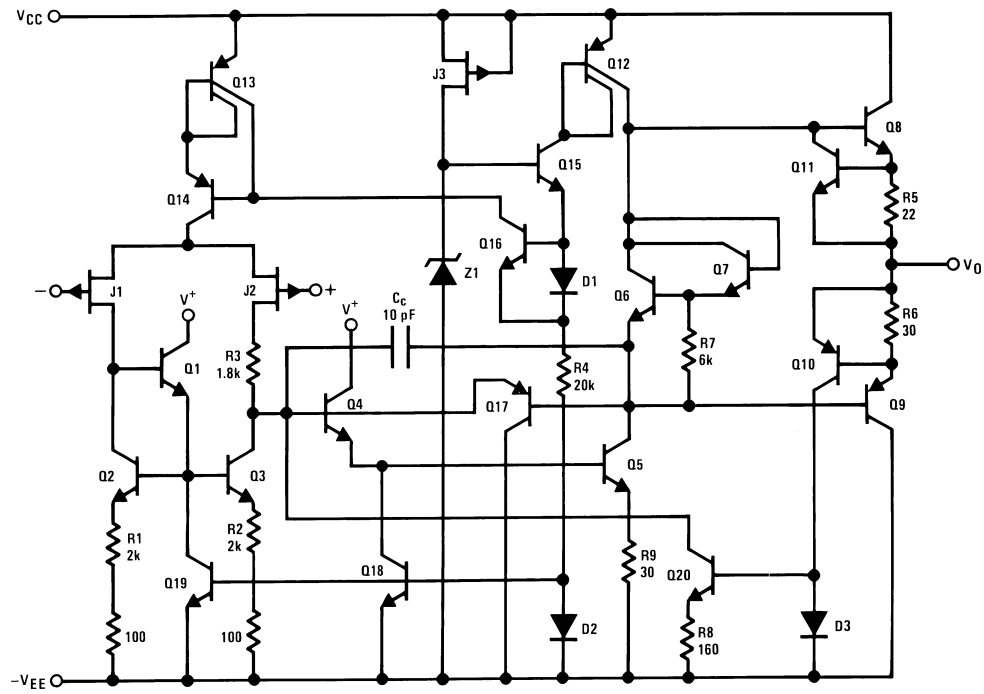

## Typical Applications

### Three-Band Active Tone Control

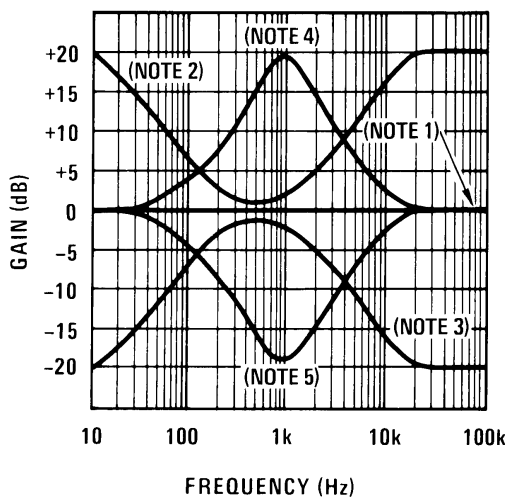
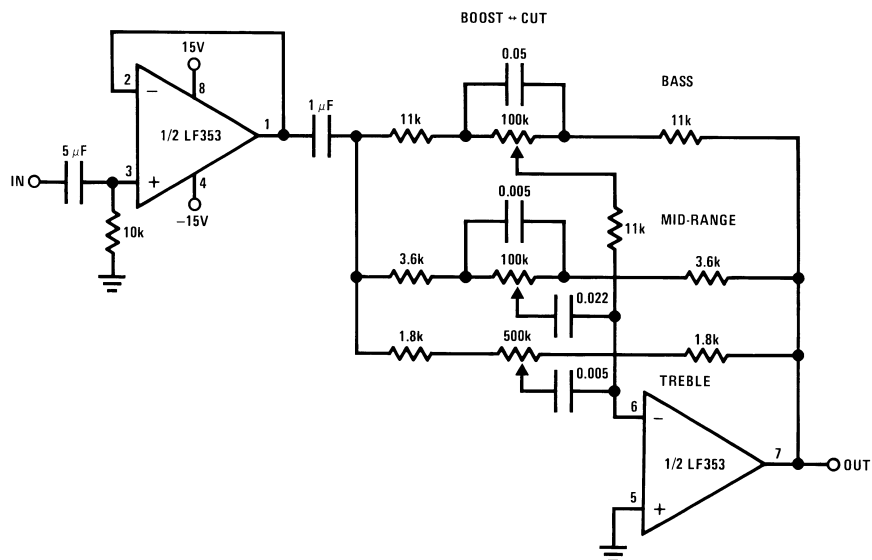

- (1) All controls flat.
- (2) Bass and treble boost, mid flat.
- (3) Bass and treble cut, mid flat.
- (4) Mid boost, bass and treble flat.
- (5) Mid cut, bass and treble flat.
  - All potentiometers are linear taper
  - Use the LF347 Quad for stereo applications

### Improved CMRR Instrumentation Amplifier

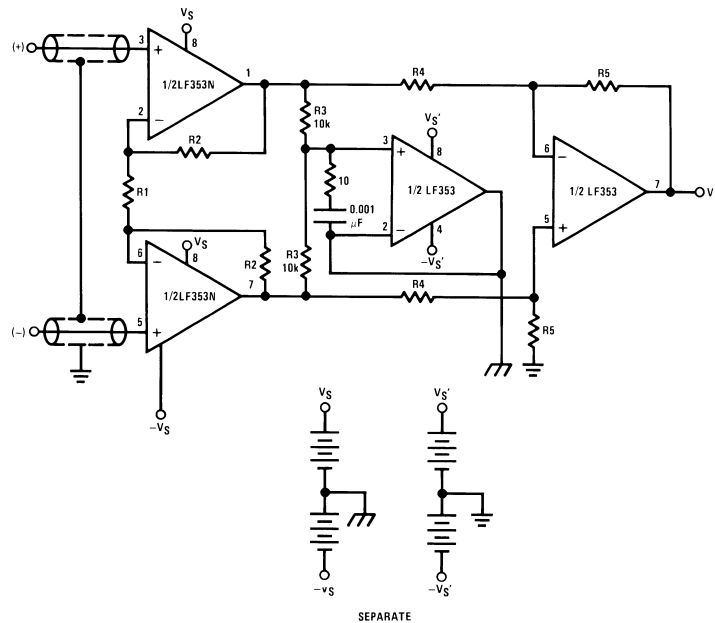

$$A_V = \left( \frac{2R_2}{R_1} + 1 \right) \frac{R_5}{R_4}$$

⏏ and ⏏ are separate isolated grounds  
 Matching of R2's, R4's and R5's control CMRR  
 With  $A_{V_T} = 1400$ , resistor matching = 0.01%: CMRR = 136 dB

- Very high input impedance
- Super high CMRR

(1)

### Fourth Order Low Pass Butterworth Filter

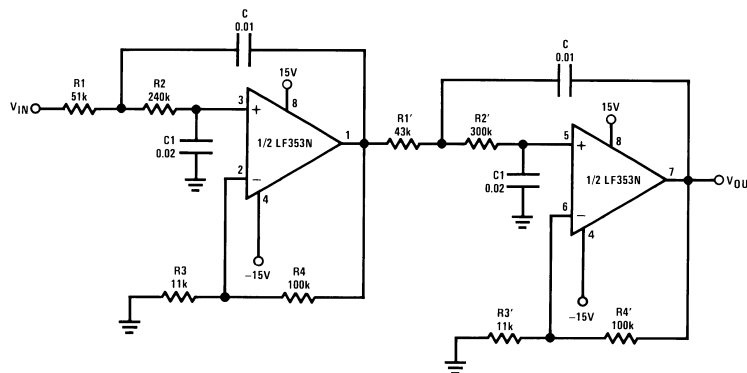

- Corner frequency ( $f_c$ ) =  $\sqrt{\frac{1}{R_1 R_2 C C_1}} \cdot \frac{1}{2\pi} = \sqrt{\frac{1}{R_1' R_2' C C_1}} \cdot \frac{1}{2\pi}$
- Passband gain ( $H_O$ ) =  $(1 + R_4/R_3) (1 + R_4'/R_3')$
- First stage Q = 1.31
- Second stage Q = 0.541
- Circuit shown uses nearest 5% tolerance resistor values for a filter with a corner frequency of 100 Hz and a passband gain of 100
- Offset nulling necessary for accurate DC performance

(2)

### Fourth Order High Pass Butterworth Filter

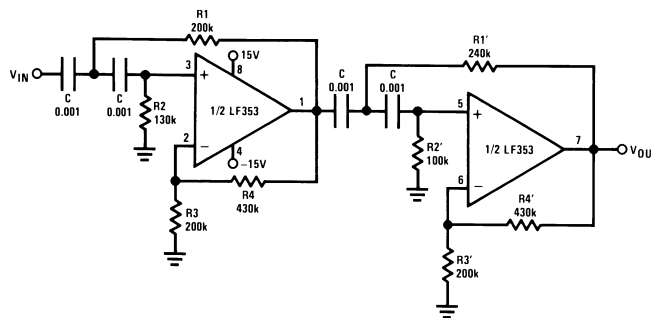

- Corner frequency ( $f_c$ ) =  $\sqrt{\frac{1}{R_1 R_2 C^2}} \cdot \frac{1}{2\pi} = \sqrt{\frac{1}{R_1' R_2' C^2}} \cdot \frac{1}{2\pi}$
- Passband gain ( $H_0$ ) =  $(1 + R_4/R_3) (1 + R_4'/R_3')$
- First stage Q = 1.31
- Second stage Q = 0.541
- Circuit shown uses closest 5% tolerance resistor values for a filter with a corner frequency of 1 kHz and a passband gain of 10.

(3)

### Ohms-to-Volts Converter

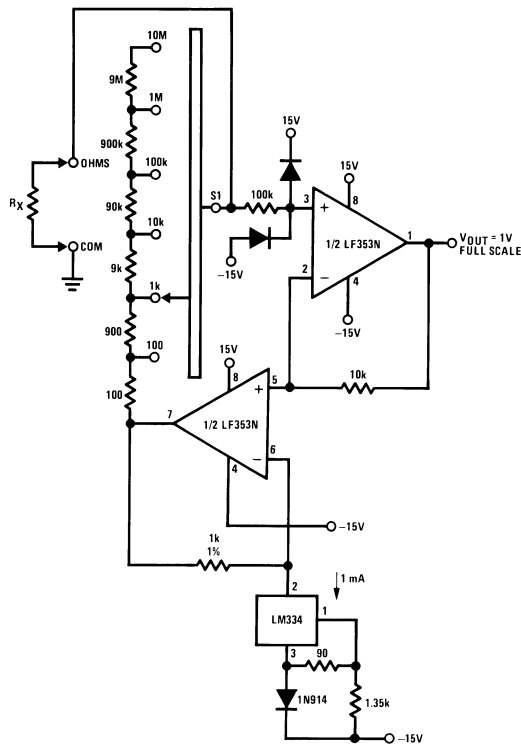

$$V_O = \frac{1V}{R_{LADDER}} \times R_X$$

Where  $R_{LADDER}$  is the resistance from switch S1 pole to pin 7 of the LF353.

(4)

### REVISION HISTORY

Changes from Revision E (March 2013) to Revision F	Page
• Changed layout of National Data Sheet to TI format .....	<a href="#">15</a>

**PACKAGING INFORMATION**

Orderable Device	Status (1)	Package Type	Package Drawing	Pins	Package Qty	Eco Plan (2)	Lead/Ball Finish (6)	MSL Peak Temp (3)	Op Temp (°C)	Device Marking (4/5)	Samples
LF353M	NRND	SOIC	D	8	95	TBD	Call TI	Call TI	0 to 70	LF353 M	
LF353M/NOPB	ACTIVE	SOIC	D	8	95	Green (RoHS & no Sb/Br)	CU SN	Level-1-260C-UNLIM	0 to 70	LF353 M	<a href="#">Samples</a>
LF353MX/NOPB	ACTIVE	SOIC	D	8	2500	Green (RoHS & no Sb/Br)	CU SN	Level-1-260C-UNLIM	0 to 70	LF353 M	<a href="#">Samples</a>
LF353N/NOPB	ACTIVE	PDIP	P	8	40	Green (RoHS & no Sb/Br)	CU SN	Level-1-NA-UNLIM	0 to 70	LF 353N	<a href="#">Samples</a>

(1) The marketing status values are defined as follows:

**ACTIVE:** Product device recommended for new designs.

**LIFEBUY:** TI has announced that the device will be discontinued, and a lifetime-buy period is in effect.

**NRND:** Not recommended for new designs. Device is in production to support existing customers, but TI does not recommend using this part in a new design.

**PREVIEW:** Device has been announced but is not in production. Samples may or may not be available.

**OBsolete:** TI has discontinued the production of the device.

(2) **RoHS:** TI defines "RoHS" to mean semiconductor products that are compliant with the current EU RoHS requirements for all 10 RoHS substances, including the requirement that RoHS substance do not exceed 0.1% by weight in homogeneous materials. Where designed to be soldered at high temperatures, "RoHS" products are suitable for use in specified lead-free processes. TI may reference these types of products as "Pb-Free".

**RoHS Exempt:** TI defines "RoHS Exempt" to mean products that contain lead but are compliant with EU RoHS pursuant to a specific EU RoHS exemption.

**Green:** TI defines "Green" to mean the content of Chlorine (Cl) and Bromine (Br) based flame retardants meet JS709B low halogen requirements of <=1000ppm threshold. Antimony trioxide based flame retardants must also meet the <=1000ppm threshold requirement.

(3) MSL, Peak Temp. - The Moisture Sensitivity Level rating according to the JEDEC industry standard classifications, and peak solder temperature.

(4) There may be additional marking, which relates to the logo, the lot trace code information, or the environmental category on the device.

(5) Multiple Device Markings will be inside parentheses. Only one Device Marking contained in parentheses and separated by a "-" will appear on a device. If a line is indented then it is a continuation of the previous line and the two combined represent the entire Device Marking for that device.

(6) Lead/Ball Finish - Orderable Devices may have multiple material finish options. Finish options are separated by a vertical ruled line. Lead/Ball Finish values may wrap to two lines if the finish value exceeds the maximum column width.

**Important Information and Disclaimer:** The information provided on this page represents TI's knowledge and belief as of the date that it is provided. TI bases its knowledge and belief on information provided by third parties, and makes no representation or warranty as to the accuracy of such information. Efforts are underway to better integrate information from third parties. TI has taken and

---

continues to take reasonable steps to provide representative and accurate information but may not have conducted destructive testing or chemical analysis on incoming materials and chemicals. TI and TI suppliers consider certain information to be proprietary, and thus CAS numbers and other limited information may not be available for release.

In no event shall TI's liability arising out of such information exceed the total purchase price of the TI part(s) at issue in this document sold by TI to Customer on an annual basis.

## IMPORTANT NOTICE AND DISCLAIMER

TI PROVIDES TECHNICAL AND RELIABILITY DATA (INCLUDING DATASHEETS), DESIGN RESOURCES (INCLUDING REFERENCE DESIGNS), APPLICATION OR OTHER DESIGN ADVICE, WEB TOOLS, SAFETY INFORMATION, AND OTHER RESOURCES "AS IS" AND WITH ALL FAULTS, AND DISCLAIMS ALL WARRANTIES, EXPRESS AND IMPLIED, INCLUDING WITHOUT LIMITATION ANY IMPLIED WARRANTIES OF MERCHANTABILITY, FITNESS FOR A PARTICULAR PURPOSE OR NON-INFRINGEMENT OF THIRD PARTY INTELLECTUAL PROPERTY RIGHTS.



These resources are intended for skilled developers designing with TI products. You are solely responsible for (1) selecting the appropriate TI products for your application, (2) designing, validating and testing your application, and (3) ensuring your application meets applicable standards, and any other safety, security, or other requirements. These resources are subject to change without notice. TI grants you permission to use these resources only for development of an application that uses the TI products described in the resource. Other reproduction and display of these resources is prohibited. No license is granted to any other TI intellectual property right or to any third party intellectual property right. TI disclaims responsibility for, and you will fully indemnify TI and its representatives against, any claims, damages, costs, losses, and liabilities arising out of your use of these resources.

TI's products are provided subject to TI's Terms of Sale ([www.ti.com/legal/termsofsale.html](http://www.ti.com/legal/termsofsale.html)) or other applicable terms available either on [ti.com](http://ti.com) or provided in conjunction with such TI products. TI's provision of these resources does not expand or otherwise alter TI's applicable warranties or warranty disclaimers for TI products.

Mailing Address: Texas Instruments, Post Office Box 655303, Dallas, Texas 75265  
Copyright © 2019, Texas Instruments Incorporated

## Looking for pricing, stock, or lifecycle information?

Click below to explore more details on WIN SOURCE:

-  [View LF353N/NOPB on WIN SOURCE](#)
-  [Texas Instruments](#) Information

## Optimize Your Supply Chain with WIN SOURCE Solutions

-  Global Sourcing Solution
-  Obsolete Management
-  Cost Control Management
-  Shortage Management
-  Alternative Solution
-  Excess Inventory Management