



THE DATASHEET OF LCP3121RL



Programmable transient voltage suppressor for SLIC protection

Datasheet - production data

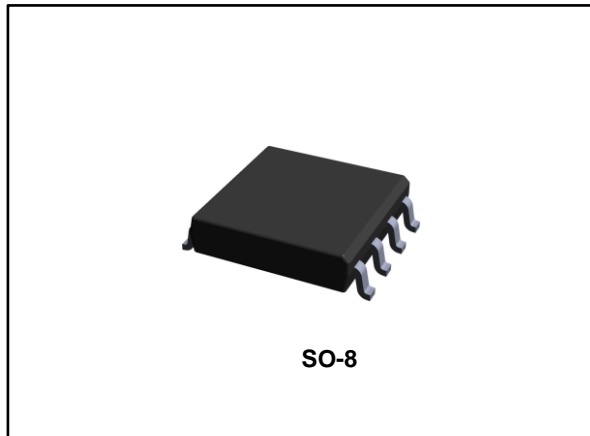

Description

This device has been especially designed to protect single and dual voltages SLICs against transient overvoltages.

Connecting gate to the right supply voltage leads to overvoltage protection.

Used with diode bridges, LCP3121RL protects several twisted pairs.

LCP3121RL can be used to help equipment to meet various standards such as UL1950, IEC 60950 / CSAC22.2, UL1459 and TIA-968-A (formerly FCC part68).

Features

- Programmable transient voltage suppressor compatible with:
 - single voltage SLICs
 - dual voltage SLICs
 - multi line SLICs
- Firing voltage range: -100 V to +100 V
- Peak pulse current:
 - $I_{PP} = 100 \text{ A}$ (10/1000 μs)
 - $I_{PP} = 150 \text{ A}$ (5/310 μs)
 - $I_{PP} = 250 \text{ A}$ (2/10 μs)
- Holding current: $I_H = 100 \text{ mA min.}$

Benefits

- A Trisil™ is not subject to ageing and provides a fail-safe mode in short circuit for a better protection.
- Trisils are used to help equipment to meet various standards such as UL1950, IEC 60950 / CSA C22.2, UL1459 and TIA-968-A (formerly FCC part 68).
- Trisils have UL94 V0 resin approved (Trisils are UL497B approved - file: E136224).

Figure 1: Functional diagram

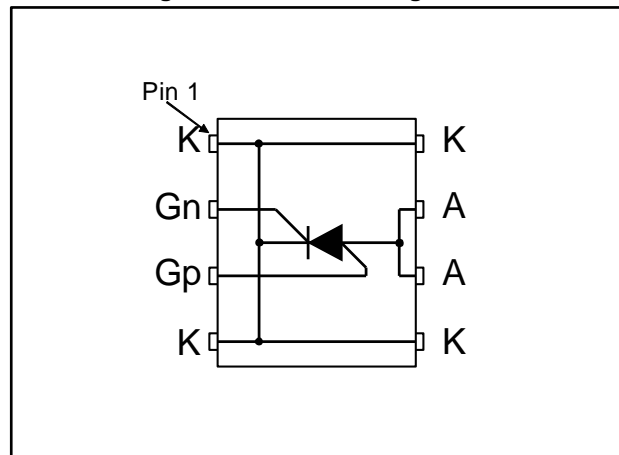

TM: Trisil is a trademark of STMicroelectronics.

1 Characteristics

Table 1: Standards compliance

Standard	Peak surge voltage (V)	Voltage waveform	Required peak current (A)	Current waveform	Minimum serial resistor to meet standard (Ω)
GR-1089 core first level	2500	2/10 μ s	500	2/10 μ s	5
	1000	10/1000 μ s	100	10/1000 μ s	0
GR-1089 core second level	5000	2/10 μ s	500	2/10 μ s	10
GR-1089 core intra-building	1500	2/10 μ s	100	2/10 μ s	0
ITU-T-K20/K21	6000	10/700 μ s	150	5/310 μ s	0
	4000		100		0
	1500		37.5		0
ITU-T-K20 (IEC 61000-4-2)	8000	1/60 ns	ESD contact discharge		0
	15000		ESD air discharge		0
IEC 61000-4-5	4000	10/700 μ s	100	5/310 μ s	0
	4000	1.2/50 μ s	100	8/20 μ s	0

Table 2: Thermal resistance

Symbol	Parameter	Value	Unit
$R_{th(j-a)}$	Junction to ambient	120	$^{\circ}\text{C/W}$

Table 3: Absolute ratings ($T_{amb} = 25^{\circ}\text{C}$)

Symbol	Parameter	Value	Unit	
I_{pp}	Peak pulse current	10/1000 μ s	100	A
		5/310 μ s	150	
		2/10 μ s	250	
I_{TSM}	Non repetitive surge peak on-state current (sinusoidal)	t = 0.1 s	25	A
		t = 1 s	8	
		t = 15 mn	3	
V_{Gn}	Negative battery voltage range	-100 to 0	V	
V_{Gp}	Positive battery voltage range	0 to 100		
T_{stg}	Storage junction temperature range	-55 to + 150	$^{\circ}\text{C}$	
T_j	Maximum operating junction temperature range			
T_L	Maximum temperature for soldering during 10 s	260	$^{\circ}\text{C}$	

Figure 2: Electrical characteristics (definitions)

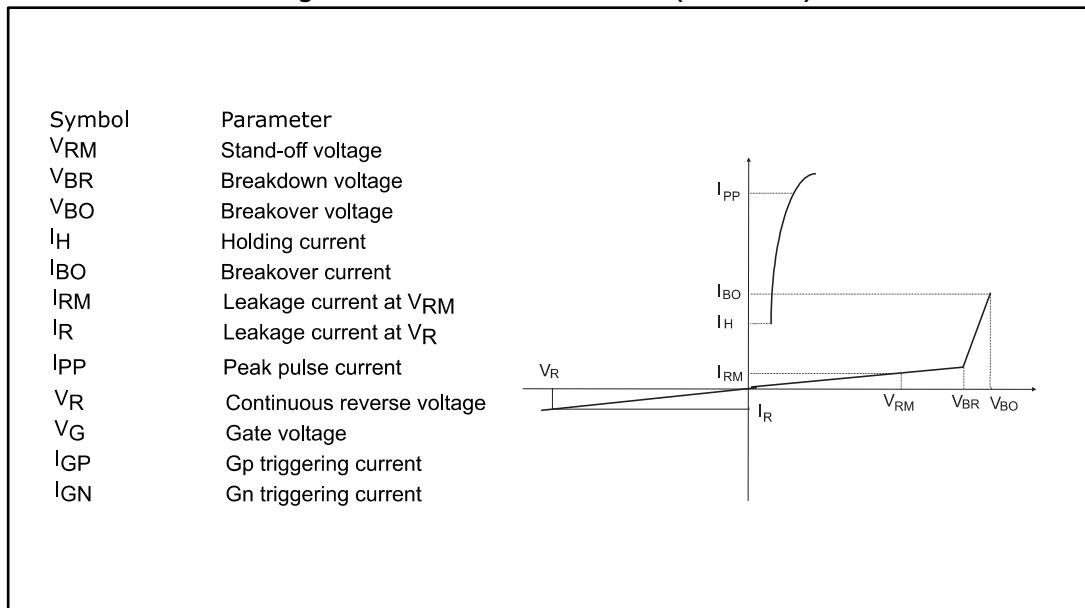
Table 4: Parameters ($T_j = 25\text{ °C}$ unless otherwise specified)

Symbol	Test conditions	Min.	Max.	Unit
I_R	$V_R = 60\text{ V}$ (between A and K) $V_R = 90\text{ V}$ (between A and K) $V_R = 180\text{ V}$ (between K and A)		5 8 50	μA
I_H	$V_{Gn} = -60\text{ V}$ or $V_{Gp} = 60\text{ V}$	100		mA
V_{BR}	$I_{BR} = 1\text{ mA}$ (between A and K, Gp and Gn not connected)	100		V
V_{GnK}	$I_G = 200\text{ mA}$ (between Gn and K)	0.6	1.8	V
V_{GpA}	$I_G = 200\text{ mA}$ (between Gp and A)	0.6	1.8	V
I_{Gn}	$V_{AK} = 60\text{ V}$		180	mA
I_{Gp}	$V_{AK} = 60\text{ V}$	80	200	mA

1.1 Characteristics (curves)

Figure 3: Surge peak current versus overload duration

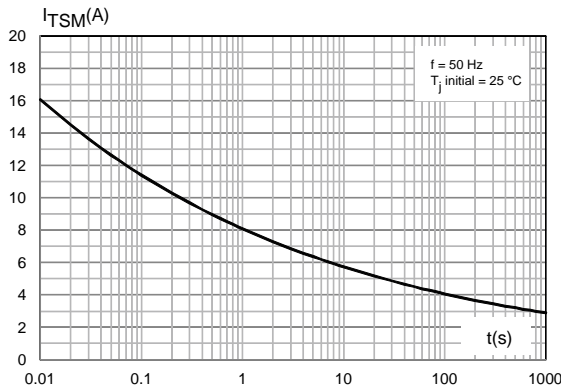

Figure 4: Relative variation of holding current versus junction temperature

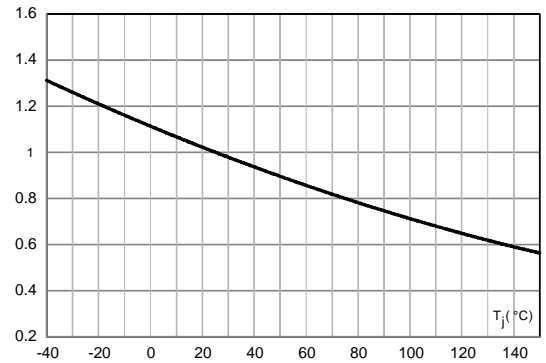

Figure 5: Schematic for single voltage SLIC

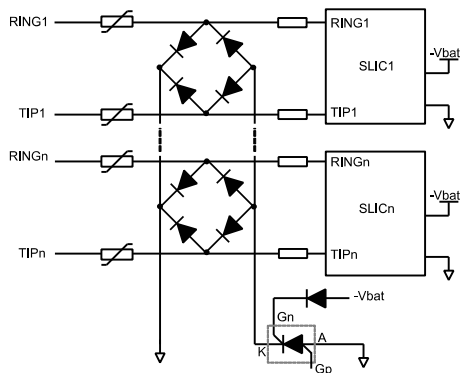
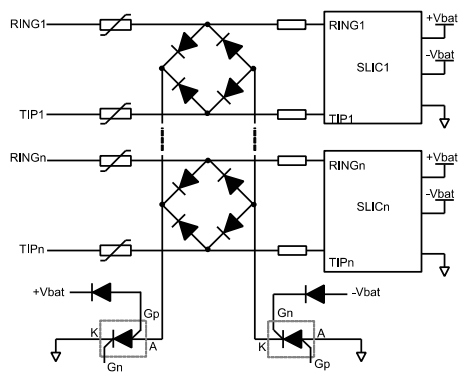
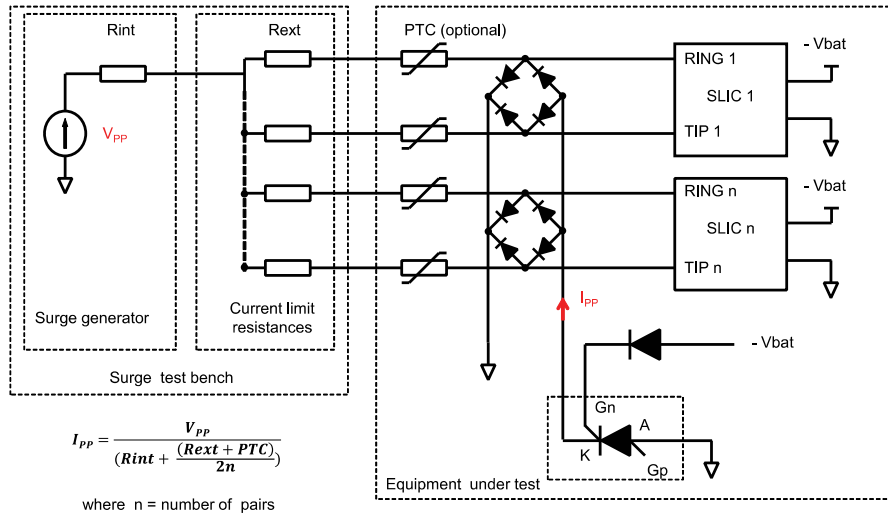

Figure 6: Schematic for dual voltage SLIC



This device is designed to protect several lines in parallel. Its surge capability must be higher than the current delivered by the surge generator depending on number of tested pairs.

Figure 7: Equivalent schematic to calculate surge current through protection



2 Package information

In order to meet environmental requirements, ST offers these devices in different grades of ECOPACK® packages, depending on their level of environmental compliance. ECOPACK® specifications, grade definitions and product status are available at: www.st.com. ECOPACK® is an ST trademark.

- Flammability: Epoxy is rated UL94V-0

2.1 SO-8 package information

Figure 8: SO-8 package outline

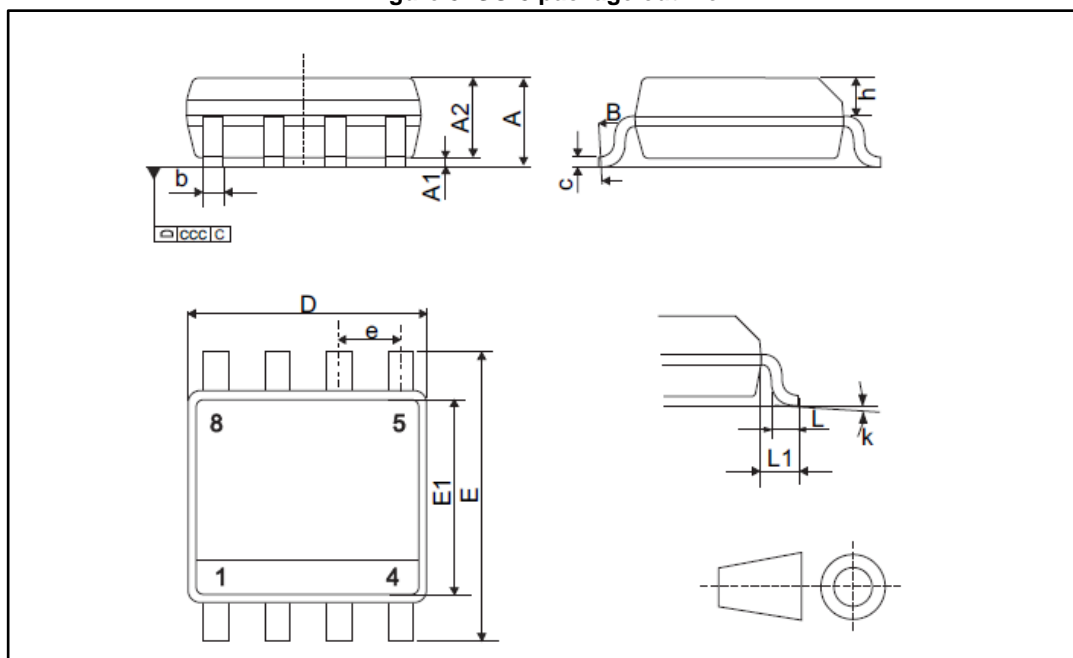

Table 5: SO-8 package mechanical data

Ref.	Dimensions					
	Millimeters			Inches		
	Min.	Typ.	Max.	Min.	Typ.	Max.
A			1.75			0.069
A1	0.1		0.25	0.004		0.010
A2	1.25			0.049		
b	0.31		0.51	0.012		0.020
c	0.10		0.25	0.004		0.010
D	4.80	4.90	5.00	0.189	0.193	0.197
E	5.80	6.00	6.20	0.228	0.236	0.244
E1	3.80	3.90	4.00	0.150	0.154	0.157
e		1.27			0.050	
h	0.25		0.50	0.010		0.020
L	0.40		1.27	0.016		0.05
L1		1.04			0.041	
k°	0		8	0		8
ccc			0.10			0.004

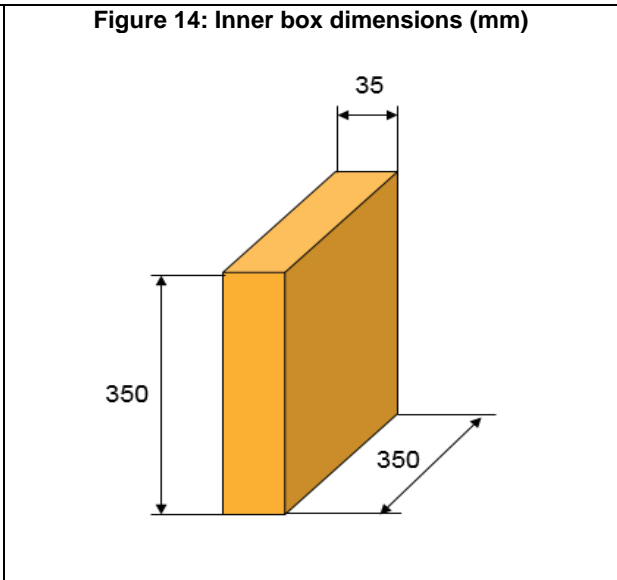
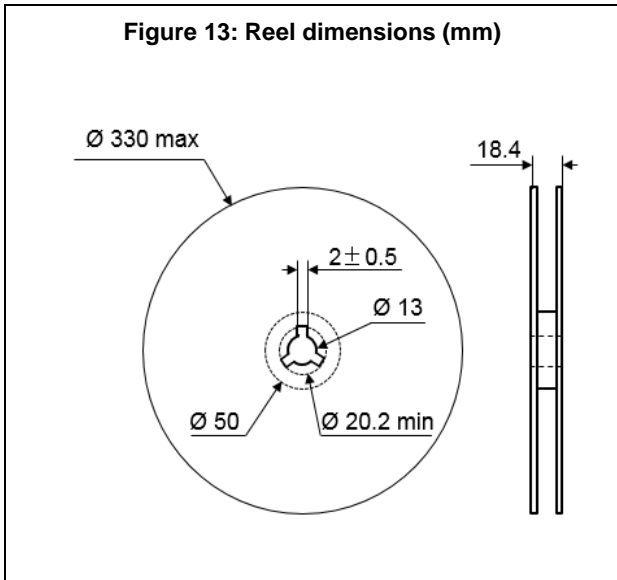
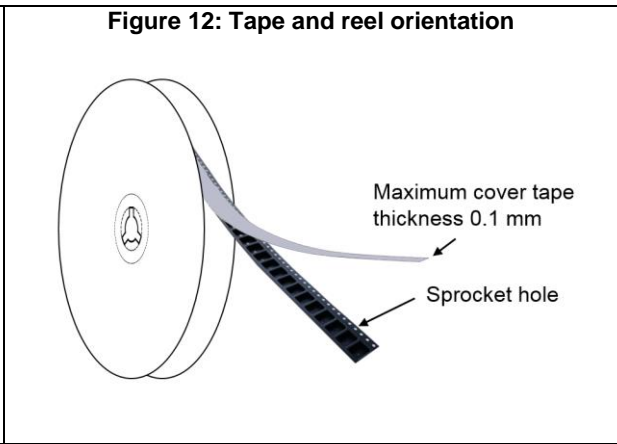
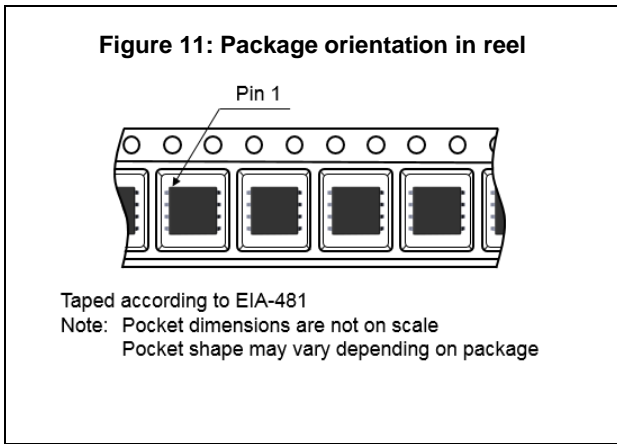
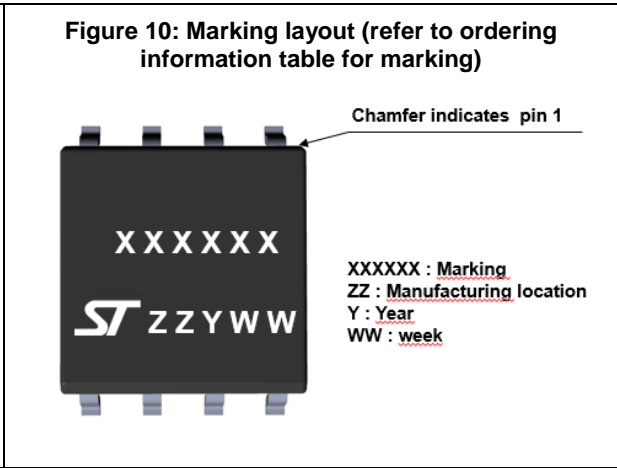
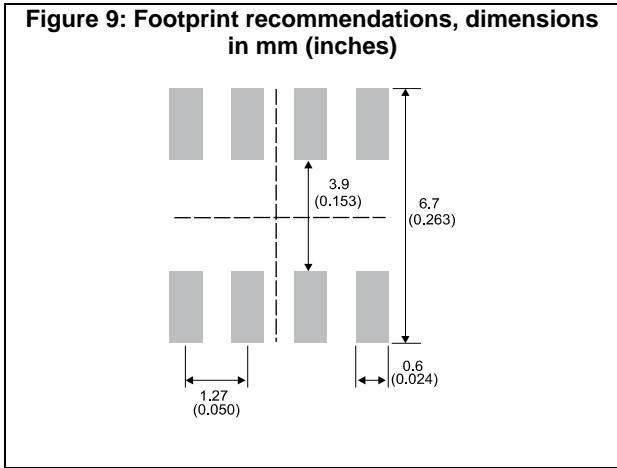

Figure 15: Tape and reel outline

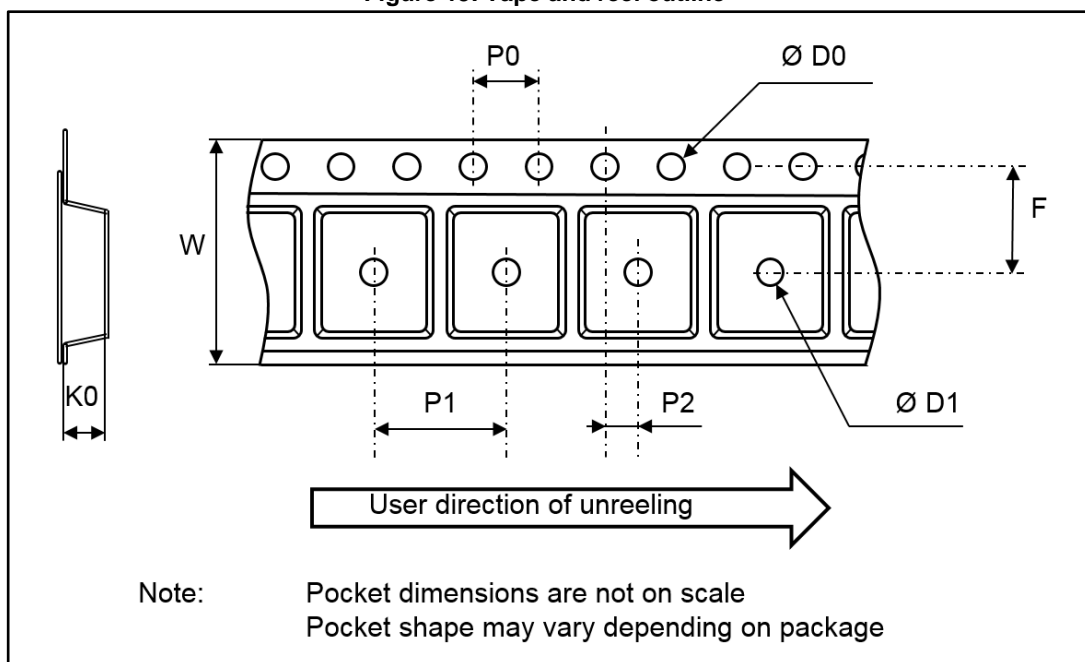
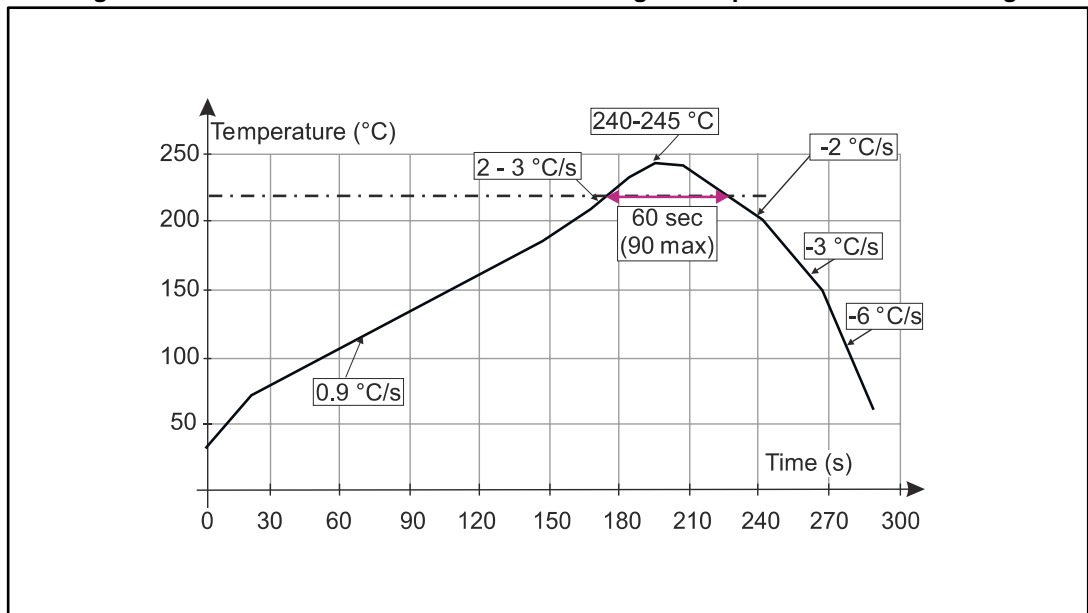

Table 6: Tape and reel mechanical data

Ref.	Dimensions		
	Millimeters		
	Min.	Typ.	Max.
P0	3.9	4	4.1
P1	7.9	8	8.1
P2	1.95	2	2.05
ØD0	1.45	1.5	1.6
ØD1	1.6		
F	5.45	5.5	5.55
K0	2.5	2.6	2.7
W	11.7	12	12.3

Figure 16: ST ECOPACK® recommended soldering reflow profile for PCB mounting



Minimize air convection currents in the reflow oven to avoid component movement. Maximum soldering profile corresponds to the latest IPC/JEDEC J-STD-020.

3 Ordering information

Table 7: Ordering information

Order code	Marking	Package	Weight	Base qty.	Delivery mode
LCP3121RL	CP3121	SO-8	0.08 g	2500	Tape and reel

4 Revision history

Table 8: Document revision history

Date	Revision	Changes
20-Dec-2016	1	Initial release.

IMPORTANT NOTICE – PLEASE READ CAREFULLY

STMicroelectronics NV and its subsidiaries ("ST") reserve the right to make changes, corrections, enhancements, modifications, and improvements to ST products and/or to this document at any time without notice. Purchasers should obtain the latest relevant information on ST products before placing orders. ST products are sold pursuant to ST's terms and conditions of sale in place at the time of order acknowledgement.

Purchasers are solely responsible for the choice, selection, and use of ST products and ST assumes no liability for application assistance or the design of Purchasers' products.

No license, express or implied, to any intellectual property right is granted by ST herein.

Resale of ST products with provisions different from the information set forth herein shall void any warranty granted by ST for such product.



ST and the ST logo are trademarks of ST. All other product or service names are the property of their respective owners.

Information in this document supersedes and replaces information previously supplied in any prior versions of this document.







© 2016 STMicroelectronics – All rights reserved

Looking for pricing, stock, or lifecycle information?

Click below to explore more details on WIN SOURCE:

-  [View LCP3121RL on WIN SOURCE](#)
-  [STMicroelectronics Information](#)

Optimize Your Supply Chain with WIN SOURCE Solutions

-  Global Sourcing Solution
-  Obsolete Management
-  Cost Control Management
-  Shortage Management
-  Alternative Solution
-  Excess Inventory Management