



ON Semiconductor®

<http://onsemi.com>

LC87F5N62B

CMOS IC

FROM 66K byte, RAM 2048 byte on-chip

8-bit 1-chip Microcontroller

Overview

The LC87F5N62B is an 8-bit microcomputer that, centered around a CPU running at a minimum bus cycle time of 83.3ns, integrate on a single chip a number of hardware features such as 66K-byte flash ROM (onboard rewritable), 2048byte RAM, Onchip debugging function, sophisticated 16-bit timers/counters (may be divided into 8-bit timers), a 16-bit timer/counter (may be divided into 8-bit timers/counters or 8-bit PWMs), four 8-bit timers with a prescaler, a base timer serving as a time-of-day clock, a high-speed clock counter, two synchronous SIO ports (with automatic block transmission/reception capabilities), an asynchronous/synchronous SIO port, two UART ports (full duplex), four 12-bit PWM channels, an 8-bit 15-channel AD converter, a system clock frequency divider, and a 29-source 10-vector interrupt feature.

Features

■Flash ROM

- Capable of on-board-programing with wide range, 2.7 to 5.5V, of voltage source
- Block-erase in 128-byte units
- 67584 × 8 bits (Address: 00000H to 0FFFFH, 1F800H to 1FFFFH)

■RAM

- 2048 × 9 bits

■Minimum Bus Cycle Time

- 83.3ns (12MHz) $V_{DD}=2.8$ to 5.5V
- 125ns (8MHz) $V_{DD}=2.5$ to 5.5V
- 500ns (2MHz) $V_{DD}=2.2$ to 5.5V

Note: Bus cycle time indicates the speed to read ROM.

* This product is licensed from Silicon Storage Technology, Inc. (USA).

LC87F5N62B

■ Minimum Instruction Cycle Time (tCYC)

- 250ns (12MHz) $V_{DD}=2.8$ to $5.5V$
- 375ns (8MHz) $V_{DD}=2.5$ to $5.5V$
- 1.5 μ s (2MHz) $V_{DD}=2.2$ to $5.5V$

■ Ports

- Normal withstand voltage I/O ports
 - Ports whose I/O direction can be designated in 1-bit units 64 (P1n, P2n, P3n, P70 to P73, P8n, PAn, PBn, PCn, S2Pn, PWM0, PWM1, XT2)
 - Ports whose I/O direction can be designated in 2-bit units 16 (PEn, PFn)
 - Ports whose I/O direction can be designated in 4-bit units 8 (P0n)
- Normal withstand voltage input port 1 (XT1)
- Dedicated oscillator ports 2 (CF1, CF2)
- Reset pins 1 (RES)
- Power pins 8 (V_{SS1} to V_{SS4} , V_{DD1} to V_{DD4})

■ Timers

- Timer 0: 16-bit timer/counter with a capture register
 - Mode 0: 8-bit timer with an 8-bit programmable prescaler (with an 8-bit capture registers) $\times 2$ channels
 - Mode 1: 8-bit timer with an 8-bit programmable prescaler (with an 8-bit capture registers) + 8-bit counter (with an 8-bit capture registers)
 - Mode 2: 16-bit timer with an 8-bit programmable prescaler (with 16-bit capture registers)
 - Mode 3: 16-bit counter (with 16-bit capture registers)
- Timer 1: 16-bit timer/counter that support PWM/toggle output
 - Mode 0: 8-bit timer with an 8-bit prescaler (with toggle outputs) + 8-bit timer/counter(with toggle outputs)
 - Mode 1: 8-bit PWM with an 8-bit prescaler $\times 2$ channels
 - Mode 2: 16-bit timer/counter with an 8-bit prescaler (with toggle outputs) (toggle outputs also from the lower-order 8-bits)
 - Mode 3: 16-bit timer with an 8-bit prescaler (with toggle outputs) (The lower-order 8 bits can be used as PWM.)
- Timer 4: 8-bit timer with a 6-bit prescaler
- Timer 5: 8-bit timer with a 6-bit prescaler
- Timer 6: 8-bit timer with a 6-bit prescaler (with toggle outputs)
- Timer 7: 8-bit timer with a 6-bit prescaler (with toggle outputs)
- Base timer
 - 1) The clock is selectable from the subclock (32.768kHz crystal oscillation), system clock, and timer 0 prescaler output.
 - 2) Interrupts programmable in 5 different time schemes.

■ High-speed Clock Counter

- 1) Can count clocks with a maximum clock rate of 24MHz (at a main clock of 12MHz).
- 2) Can generate output real-time.

■ SIO

- SIO0: 8-bit synchronous serial interface
 - 1) LSB first/MSB first mode selectable
 - 2) Built-in 8-bit baudrate generator (maximum transfer clock cycle = $4/3$ tCYC)
 - 3) Automatic continuous data transmission (1 to 256 bits, specifiable in 1-bit units, suspension and resumption of data transmission possible in 1-byte units)
- SIO1: 8-bit asynchronous/synchronous serial interface
 - Mode 0: Synchronous 8-bit serial I/O (2- or 3-wire configuration, 2 to 512 tCYC transfer clocks)
 - Mode 1: Asynchronous serial I/O (half-duplex, 8 data bits, 1 stop bit, 8 to 2048 tCYC baudrates)
 - Mode 2: Bus mode 1 (start bit, 8 data bits, 2 to 512 tCYC transfer clocks)
 - Mode 3: Bus mode 2 (start detect, 8 data bits, stop detect)
- SIO2: 8 bit synchronous serial interface
 - 1) LSB first mode
 - 2) Built-in 8-bit baudrate generator (maximum transfer clock cycle = $4/3$ tCYC)
 - 3) Automatic continuous data transmission (1 to 32 bytes)

LC87F5N62B

■UART: 2 channels

- Full duplex
- 7/8/9 bit data bits selectable
- 1 stop bit (2 bit in continuous transmission mode)
- Built-in baudrate generator (with baudrates of 16/3 to 8192/3 tCYC)

■AD Converter: 8 bits × 15 channels

■PWM: Multifrequency 12-bit PWM × 4 channels

■Remote Control Receiver Circuit (sharing pins with P73, INT3, and T0IN)

- 1) Noise filtering function (noise filter time constant selectable from 1 tCYC, 32 tCYC, and 128 tCYC)
- 2) The noise filtering function is available for the INT3, T0IN, or T0HCP signal at P73. When P73 is read with an instruction, the signal level at that pin is read regardless of the availability of the noise filtering function.

■Watchdog Timer

- External RC watchdog timer
- Interrupt and reset signals selectable

■Clock Output Function

- 1) Able to output selected oscillation clock 1/1, 1/2, 1/4, 1/8, 1/16, 1/32, 1/64 as system clock.
- 2) Able to output oscillation clock of sub clock.

■Interrupts

- 29 sources, 10 vector addresses
 - 1) Provides three levels (low (L), high (H), and highest (X)) of multiplex interrupt control. Any interrupt requests of the level equal to or lower than the current interrupt are not accepted.
 - 2) When interrupt requests to two or more vector addresses occur at the same time, the interrupt of the highest level takes precedence over the other interrupts. For interrupts of the same level, the interrupt into the smallest vector address takes precedence.

No.	Vector Address	Level	Interrupt Source
1	00003H	X or L	INT0
2	0000BH	X or L	INT1
3	00013H	H or L	INT2/T0L/INT4
4	0001BH	H or L	INT3/INT5/base timer0/base timer1
5	00023H	H or L	T0H/INT6
6	0002BH	H or L	T1L/T1H/INT7
7	00033H	H or L	SIO0/UART1 receive/UART2 receive
8	0003BH	H or L	SIO/SIO2/UART1 transmit/UART2 transmit
9	00043H	H or L	ADC/T6/T7/PWM4, PWM5
10	0004BH	H or L	Port 0/T4/T5/PWM0, PWM1

- Priority levels $X > H > L$
- Of interrupts of the same level, the one with the smallest vector address takes precedence.

■Subroutine Stack Levels: 1024 levels maximum (the stack is allocated in RAM)

■High-speed Multiplication/Division Instructions

- 16-bits × 8-bits (5 tCYC execution time)
- 24-bits × 16-bits (12 tCYC execution time)
- 16-bits ÷ 8-bits (8 tCYC execution time)
- 24-bits ÷ 16-bits (12 tCYC execution time)

■Oscillation Circuits

- RC oscillation circuit (internal) : For system clock
- CF oscillation circuit : For system clock, with internal Rf
- Crystal oscillation circuit : For low-speed system clock
- Multifrequency RC oscillation circuit (internal) : For system clock

LC87F5N62B

■System Clock Divider Function

- Can run on low current.
- The minimum instruction cycle selectable from 250ns, 500ns, 1.0μs, 2.0μs, 4.0μs, 8.0μs, 16.0μs, 32.0μs, and 64.0μs (at a main clock rate of 12MHz).

■Standby Function

- HALT mode: Halts instruction execution while allowing the peripheral circuits to continue operation.
 - 1) Oscillation is not halted automatically.
 - 2) Canceled by a system reset or occurrence of interrupt.
- HOLD mode: Suspends instruction execution and the operation of the peripheral circuits.
 - 1) The CF, RC, and crystal oscillators automatically stop operation.
 - 2) There are three ways of resetting the HOLD mode.
 - (1) Setting the reset pin to the low level.
 - (2) Setting at least one of the INT0, INT1, INT2, INT4, and INT5 pins to the specified level
 - (3) Having an interrupt source established at port 0
- X'tal HOLD mode: Suspends instruction execution and the operation of the peripheral circuits except the base timer.
 - 1) The CF and RC oscillators automatically stop operation.
 - 2) The state of crystal oscillation established when the HOLD mode is entered is retained.
 - 3) There are four ways of resetting the X'tal HOLD mode.
 - (1) Setting the reset pin to the low level
 - (2) Setting at least one of the INT0, INT1, INT2, INT4, and INT5 pins to the specified level
 - (3) Having an interrupt source established at port 0
 - (4) Having an interrupt source established in the base timer circuit

■On-chip Debugger Function

- Permits software debugging with the test device installed on the target board.

■Package Form

- QIP100E (14 × 20) : “Lead-free type”

■Development Tools

- Evaluation (EVA) chip : LC87EV690
- Emulator : EVA62S + ECB876600D + SUB875C00 + POD100QFP
ICE-B877300 + SUB875C00 + POD100QFP
- On-chip-debugger : TCB87-TypeB + LC87F5NC8A or LC87F5N62B

■Programming Boards

Package	Programming boards
QIP100E (14 × 20)	W87F52256Q

■Flash ROM Programmer

Maker	Model	Support version(Note)	Device
Flash Support Group, Inc. (Single)	AF9708/09/09B (including product of Ando Electric Co.,Ltd)	Revision : After Rev.02.73	LC87F76C8A
Flash Support Group, Inc.(Gang)	AF9723(Main body) (including product of Ando Electric Co.,Ltd)	Revision : After Rev.02.29	LC87F5NC8A
	AF9833(Unit) (including product of Ando Electric Co.,Ltd)	Revision : After Rev.01.88	
Our company	SKK/SKK Type-B/SKK DBG Type-B (SANYO FWS)	Application Version: After 1.04 Chip Data Version: After2.14	LC87F5NC8A

Package Dimensions

unit : mm (typ)

3151A

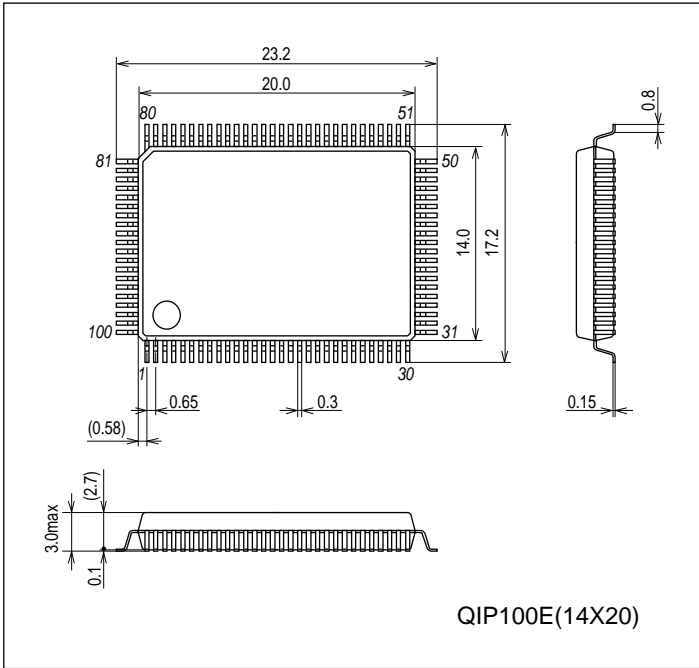

LC87F5N62B

Pin Assignment

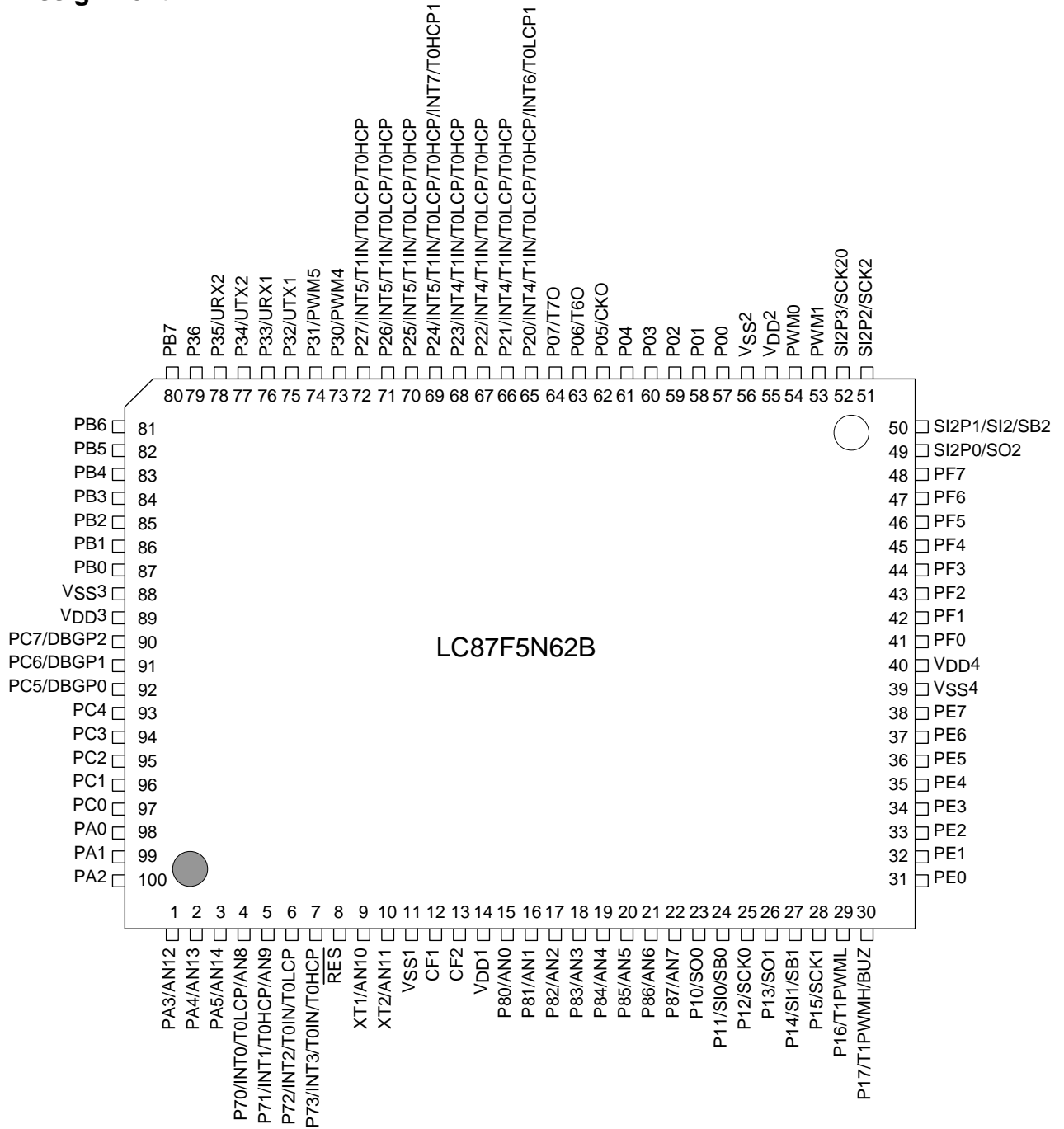

Top view

QIP100E(14×20) “Lead-free Type”

System Block Diagram

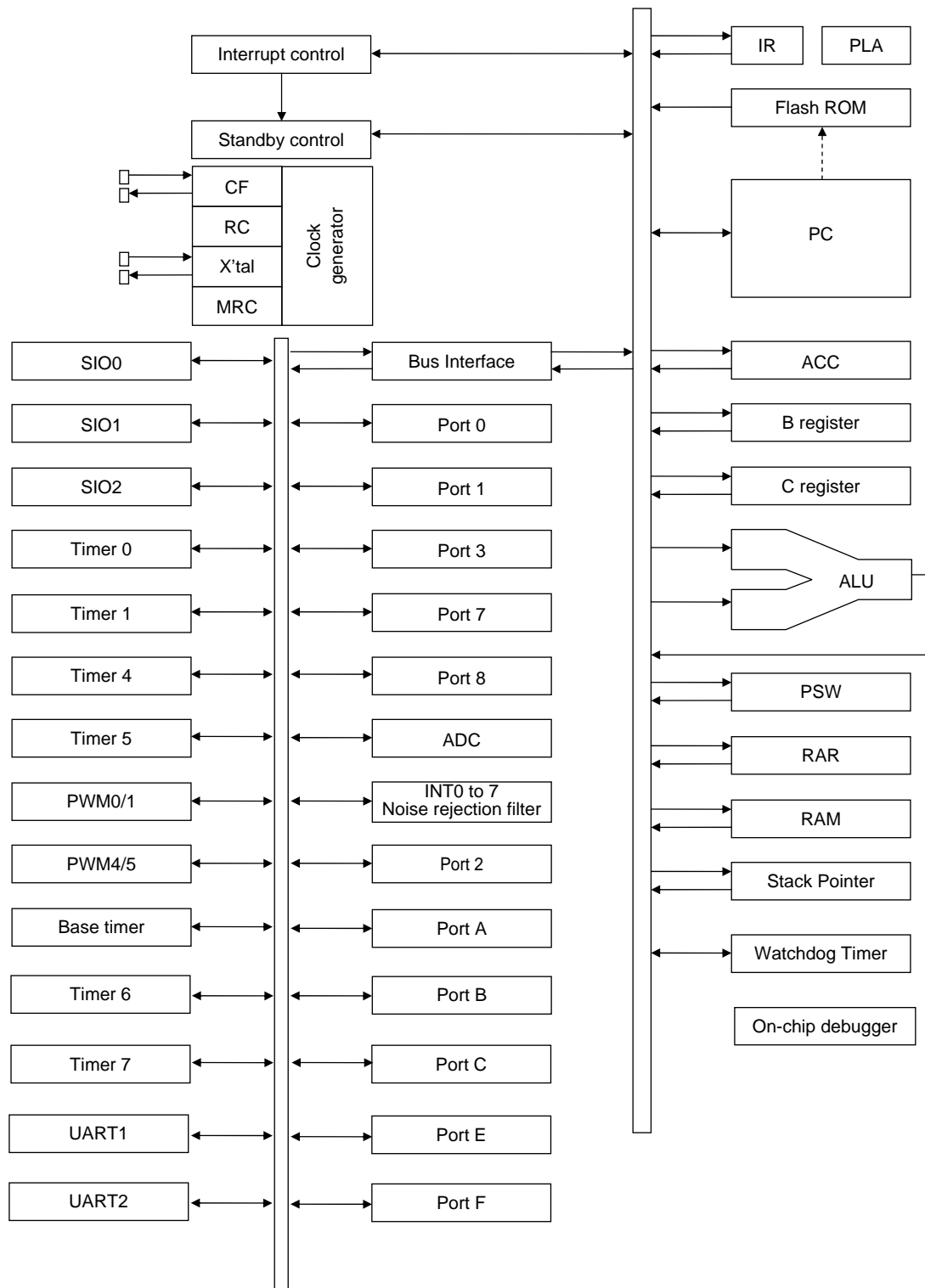

LC87F5N62B

Pin Description

Pin Name	I/O	Description	Option																														
V _{SS1} , V _{SS2} V _{SS3} , V _{SS4}	-	- Power supply pin	No																														
V _{DD1} , V _{DD2} V _{DD3} , V _{DD4}	-	+ Power supply pin	No																														
Port 0 P00 to P07	I/O	<ul style="list-style-type: none"> • 8-bit I/O port • I/O specifiable in 4-bit units • Pull-up resistor can be turned on and off in 4-bit units • HOLD release input • Port 0 interrupt input • Pin functions <ul style="list-style-type: none"> P05: System clock output P06: Timer 6 toggle output P07: Timer 7 toggle output 	Yes																														
Port 1 P10 to P17	I/O	<ul style="list-style-type: none"> • 8-bit I/O port • I/O specifiable in 1-bit units • Pull-up resistor can be turned on and off in 1-bit units • Pin functions <ul style="list-style-type: none"> P10: SIO0 data output P11: SIO0 data input, bus I/O P12: SIO0 clock I/O P13: SIO1 data output P14: SIO1 data input, bus I/O P15: SIO1 clock I/O P16: Timer 1 PWML output P17: Timer 1 PWMH output, Beeper output 	Yes																														
Port 2 P20 to P27	I/O	<ul style="list-style-type: none"> • 8-bit I/O port • I/O specifiable in 1-bit units • Pull-up resistor can be turned on and off in 1-bit units • Other functions <ul style="list-style-type: none"> P20: INT4 input/HOLD reset input/timer 1 event input/timer 0L capture input/ timer 0H capture input/INT6 input/timer 0L capture 1 input P21 to P23: INT4 input/HOLD reset input/timer 1 event input/timer 0L capture input/ timer 0H capture input P24: INT5 input/HOLD reset input/timer 1 event input/timer 0L capture input/ timer 0H capture input/INT7 input/timer 0H capture 1 input P25 to P27: INT5 input/HOLD reset input/timer 1 event input/timer 0L capture input/ timer 0H capture input • Interrupt acknowledge type <table border="1" style="margin-left: 20px; width: 100%; border-collapse: collapse; text-align: center;"> <thead> <tr> <th></th> <th>Rising</th> <th>Falling</th> <th>Rising/ Falling</th> <th>H level</th> <th>L level</th> </tr> </thead> <tbody> <tr> <td>INT4</td> <td>enable</td> <td>enable</td> <td>enable</td> <td>disable</td> <td>disable</td> </tr> <tr> <td>INT5</td> <td>enable</td> <td>enable</td> <td>enable</td> <td>disable</td> <td>disable</td> </tr> <tr> <td>INT6</td> <td>enable</td> <td>enable</td> <td>enable</td> <td>disable</td> <td>disable</td> </tr> <tr> <td>INT7</td> <td>enable</td> <td>enable</td> <td>enable</td> <td>disable</td> <td>disable</td> </tr> </tbody> </table> 		Rising	Falling	Rising/ Falling	H level	L level	INT4	enable	enable	enable	disable	disable	INT5	enable	enable	enable	disable	disable	INT6	enable	enable	enable	disable	disable	INT7	enable	enable	enable	disable	disable	Yes
	Rising	Falling	Rising/ Falling	H level	L level																												
INT4	enable	enable	enable	disable	disable																												
INT5	enable	enable	enable	disable	disable																												
INT6	enable	enable	enable	disable	disable																												
INT7	enable	enable	enable	disable	disable																												
Port 3 P30 to P36	I/O	<ul style="list-style-type: none"> • 7-bit I/O port • I/O specifiable in 1-bit units • Pull-up resistor can be turned on and off in 1-bit units • Pin functions <ul style="list-style-type: none"> P30: PWM4 output P31: PWM5 output P32: UART1 transmit P33: UART1 receive P34: UART2 transmit P35: UART2 receive 	Yes																														

Continued on next page.

LC87F5N62B

Continued from preceding page.

Pin Name	I/O	Description	Option																														
Port 7	I/O	<ul style="list-style-type: none"> • 4-bit I/O port • I/O specifiable in 1-bit units • Pull-up resistor can be turned on and off in 1-bit units • Other functions P70: INT0 input/HOLD release input/Timer 0L capture input/Output for watchdog timer P71: INT1 input/HOLD release input/Timer 0H capture input P72: INT2 input/HOLD release input/Timer 0 event input/Timer 0L capture input P73: INT3 input with noise filter/Timer 0 event input/Timer 0H capture input <ul style="list-style-type: none"> • Interrupt acknowledge type <table border="1" style="width: 100%; border-collapse: collapse; text-align: center;"> <thead> <tr> <th></th> <th>Rising</th> <th>Falling</th> <th>Rising/ Falling</th> <th>H level</th> <th>L level</th> </tr> </thead> <tbody> <tr> <td>INT0</td> <td>enable</td> <td>enable</td> <td>disable</td> <td>enable</td> <td>enable</td> </tr> <tr> <td>INT1</td> <td>enable</td> <td>enable</td> <td>disable</td> <td>enable</td> <td>enable</td> </tr> <tr> <td>INT2</td> <td>enable</td> <td>enable</td> <td>enable</td> <td>disable</td> <td>disable</td> </tr> <tr> <td>INT3</td> <td>enable</td> <td>enable</td> <td>enable</td> <td>disable</td> <td>disable</td> </tr> </tbody> </table> <ul style="list-style-type: none"> • AD converter input port: AN8 (P70), AN9 (P71) 		Rising	Falling	Rising/ Falling	H level	L level	INT0	enable	enable	disable	enable	enable	INT1	enable	enable	disable	enable	enable	INT2	enable	enable	enable	disable	disable	INT3	enable	enable	enable	disable	disable	No
			Rising	Falling	Rising/ Falling	H level	L level																										
INT0	enable	enable	disable	enable	enable																												
INT1	enable	enable	disable	enable	enable																												
INT2	enable	enable	enable	disable	disable																												
INT3	enable	enable	enable	disable	disable																												
P70 to P73																																	
Port 8	I/O	<ul style="list-style-type: none"> • 8-bit I/O port • I/O specifiable in 1-bit units • Other functions P80 to P87: AD converter input port	No																														
P80 to P87																																	
Port A	I/O	<ul style="list-style-type: none"> • 6-bit I/O port • I/O specifiable in 1-bit units • Pull-up resistor can be turned on and off in 1-bit units 	Yes																														
PA0 to PA5																																	
Port B	I/O	<ul style="list-style-type: none"> • 8-bit I/O port • I/O specifiable in 1-bit units • Pull-up resistor can be turned on and off in 1-bit units 	Yes																														
PB0 to PB7																																	
Port C	I/O	<ul style="list-style-type: none"> • 8-bit I/O port • I/O specifiable in 1-bit units • Pull-up resistor can be turned on and off in 1-bit units • Pin functions DBG0 to DBG2 (PC5 to PC7): On-chip Debugger	Yes																														
PC0 to PC7																																	
Port E	I/O	<ul style="list-style-type: none"> • 8-bit I/O port • I/O specifiable in 2-bit units • Pull-up resistor can be turned on and off in 1-bit units 	No																														
PE0 to PE7																																	
Port F	I/O	<ul style="list-style-type: none"> • 8-bit I/O port • I/O specifiable in 2-bit units • Pull-up resistor can be turned on and off in 1-bit units 	No																														
PF0 to PF7																																	
SIO2 Port	I/O	<ul style="list-style-type: none"> • 4-bit I/O port • I/O specifiable in 1-bit units • Shared functions: SI2P0: SIO2 data output SI2P1: SIO2 data input, bus input/output SI2P2: SIO2 clock input/output SI2P3: SIO2 clock output	No																														
SI2P0 to SI2P3																																	
PWM0, PWM1	O	<ul style="list-style-type: none"> • PWM0, PWM1 output port • General-purpose I/O available 	No																														
$\overline{\text{RES}}$	I	Reset pin	No																														
XT1	I	<ul style="list-style-type: none"> • Input terminal for 32.768kHz X'tal oscillation • Shared functions: AN10: AD converter input port General-purpose input port Must be connected to V_{DD1} if not to be used.	No																														
XT2	I/O	<ul style="list-style-type: none"> • Output terminal for 32.768kHz X'tal oscillation • Shared functions: AN11: AD converter input port General-purpose I/O port Must be set for oscillation and kept open if not to be used.	No																														
CF1	I	Ceramic resonator input pin	No																														
CF2	O	Ceramic resonator output pin	No																														

LC87F5N62B

Port Output Types

The table below lists the types of port outputs and the presence/absence of a pull-up resistor. Data can be read into any input port even if it is in the output mode.

Port	Options Selected in Units of	Option Type	Output Type	Pull-up Resistor
P00 to P07	1 bit	1	CMOS	Programmable (Note 1)
		2	N-channel open drain	No
P10 to P17	1 bit	1	CMOS	Programmable
		2	N-channel open drain	Programmable
P20 to P27	1 bit	1	CMOS	Programmable
		2	N-channel open drain	Programmable
P30 to P36	1 bit	1	CMOS	Programmable
		2	N-channel open drain	Programmable
P70	-	No	N-channel open drain	Programmable
P71 to P73	-	No	CMOS	Programmable
P80 to P87	-	No	N-channel open drain	No
PA0 to PA5	1 bit	1	CMOS	Programmable
		2	N-channel open drain	Programmable
PB0 to PB7	1 bit	1	CMOS	Programmable
		2	N-channel open drain	Programmable
PC0 to PC7	1 bit	1	CMOS	Programmable
		2	N-channel open drain	Programmable
PE0 to PE7	-	No	CMOS	Programmable
PF0 to PF7	-	No	CMOS	Programmable
SI2P0, SI2P2 SI2P3	-	No	CMOS	No
SI2P1	-	No	CMOS (when selected as ordinary port) N-channel open drain (When SIO2 data is selected)	No
PWM0, PWM1	-	No	CMOS	No
XT1	-	No	Input only	No
XT2	-	No	Output for 32.768kHz quartz oscillator N-channel open drain (when in general-purpose No output mode)	No

Note 1: Programmable pull-up resistors for port 0 are controlled in 4-bit units (P00 to 03, P04 to 07).

*1: Make the following connection to minimize the noise input to the V_{DD1} pin and prolong the backup time. Be sure to electrically short the V_{SS1}, V_{SS2}, V_{SS3} and V_{SS4} pins.

(Example 1) When backup is active in the HOLD mode, the high level of the port outputs is supplied by the backup capacitors.

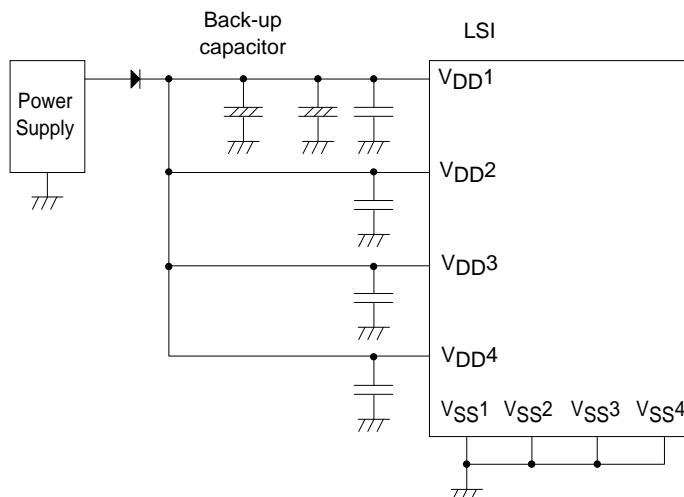

LC87F5N62B

(Example 2) The high-level output at the ports is unstable when the HOLD mode backup is in effect.

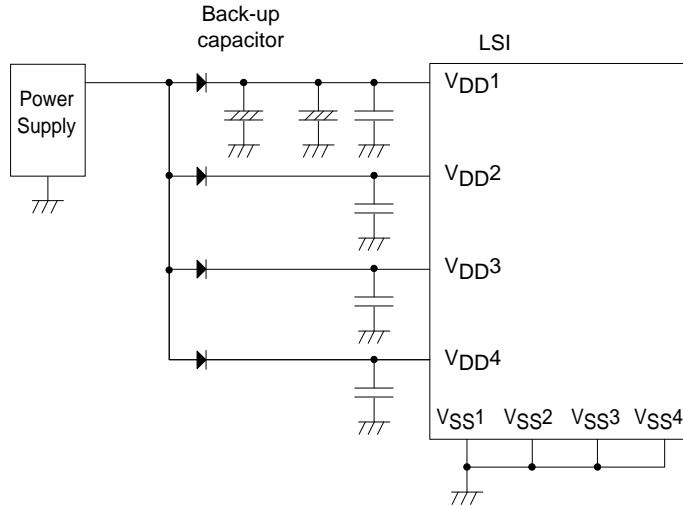

Absolute Maximum Ratings at $T_a = 25^\circ\text{C}$, $V_{SS1} = V_{SS2} = V_{SS3} = V_{SS4} = 0\text{V}$

Parameter	Symbol	Pins/Remarks	Conditions	Specification				
				$V_{DD}[\text{V}]$	min	typ	max	unit
Maximum Supply voltage	$V_{DD \text{ max}}$	$V_{DD1}, V_{DD2}, V_{DD3}, V_{DD4}$	$V_{DD1}=V_{DD2}=V_{DD3}=V_{DD4}$		-0.3		+6.5	V
Input voltage	$V_I(1)$	XT1, CF1			-0.3		$V_{DD}+0.3$	
Input/Output Voltage	$V_{IO}(1)$	Ports 0, 1, 2 Ports 3, 7, 8 Ports A, B, C, E, F SI2P0 to SI2P3 PWM0, PWM1, XT2			-0.3		$V_{DD}+0.3$	
High level output current	Peak output current	IOPH(1)	Ports 0, 1, 2, 3 Ports A, B, C, E, F SI2P0 to SI2P3	CMOS output select per 1 application pin		-10		mA
		IOPH(2)	PWM0, PWM1	Per 1 application pin.		-20		
		IOPH(3)	P71 to P73	Per 1 application pin.		-5		
	Average output current (Note1-1)	IOMH(1)	Ports 0, 1, 2, 3 Ports A, B, C, E, F SI2P0 to SI2P3	CMOS output select per 1 application pin		-7.5		
		IOMH(2)	PWM0, PWM1	Per 1 application pin.		-10		
		IOMH(3)	P71 to P73	Per 1 application pin.		-3		
	Total output current	$\Sigma\text{IOAH}(1)$	P71 to P73	Total of all applicable pins		-10		
			PWM0, PWM1 SI2P0 to SI2P3	Total of all applicable pins		-25		
		$\Sigma\text{IOAH}(3)$	Port 0	Total of all applicable pins		-25		
			Port 0 PWM0, PWM1 SI2P0 to SI2P3	Total of all applicable pins		-45		
$\Sigma\text{IOAH}(5)$		Ports 2, 3, B	Total of all applicable pins		-25			
$\Sigma\text{IOAH}(6)$		Ports A, C	Total of all applicable pins		-25			
$\Sigma\text{IOAH}(7)$		Ports 2, 3, A, B, C	Total of all applicable pins		-45			
$\Sigma\text{IOAH}(8)$	Port F	Total of all applicable pins		-25				
$\Sigma\text{IOAH}(9)$	Ports 1, E	Total of all applicable pins		-25				
$\Sigma\text{IOAH}(10)$	Ports 1, E, F	Total of all applicable pins		-45				

Note 1-1: Average output current is average of current in 100ms interval.

Continued on next page.

LC87F5N62B

Continued from preceding page.

Parameter	Symbol	Pins/Remarks	Conditions	V _{DD} [V]	Specification			unit
					min	typ	max	
Low level output current	Peak output current	IOPL(1)	P02 to P07 Ports 1, 2, 3 Ports A, B, C, E, F SI2P0 to SI2P3 PWM0, PWM1	Per 1 application pin.			20	mA
		IOPL(2)	P00, P01	Per 1 application pin.			30	
		IOPL(3)	Ports 7, 8, XT2	Per 1 application pin.			10	
	Average output current (Note1-1)	IOML(1)	P02 to P07 Ports 1, 2, 3 Ports A, B, C, E, F SI2P0 to SI2P3 PWM0, PWM1	Per 1 application pin.			15	
		IOML(2)	P00, P01	Per 1 application pin.			20	
		IOML(3)	Ports 7, 8, XT2	Per 1 application pin.			7.5	
	Total output current	ΣIOAL(1)	Port 7, XT2	Total of all applicable pins			15	
		ΣIOAL(2)	Port 8	Total of all applicable pins			15	
		ΣIOAL(3)	Ports 7, 8, XT2	Total of all applicable pins			20	
		ΣIOAL(4)	PWM0, PWM1 SI2P0 to SI2P3	Total of all applicable pins			45	
		ΣIOAL(5)	Port 0	Total of all applicable pins			45	
		ΣIOAL(6)	Port 0 PWM0, PWM1 SI2P0 to SI2P3	Total of all applicable pins			80	
ΣIOAL(7)		Ports 2, 3, B	Total of all applicable pins			45		
ΣIOAL(8)		Ports A, C	Total of all applicable pins			45		
ΣIOAL(9)		Ports 2, 3, A, B, C	Total of all applicable pins			80		
ΣIOAL(10)		Port F	Total of all applicable pins			45		
ΣIOAL(11)		Ports 1, E	Total of all applicable pins			45		
ΣIOAL(12)		Ports 1, E, F	Total of all applicable pins			80		
Maximum power dissipation	Pd max	QIP100E(14×20)	Ta=-40 to +85°C			320	mW	
Operating ambient temperature	Topr				-40	+85	°C	
Storage ambient temperature	Tstg				-55	+125		

Note 1-1: Average output current is average of current in 100ms interval.

Stresses exceeding Maximum Ratings may damage the device. Maximum Ratings are stress ratings only. Functional operation above the Recommended Operating Conditions is not implied. Extended exposure to stresses above the Recommended Operating Conditions may affect device reliability.

LC87F5N62B

Recommended Operating Conditions at $T_a = -40^{\circ}\text{C}$ to $+85^{\circ}\text{C}$, $V_{SS1} = V_{SS2} = V_{SS3} = V_{SS4} = 0\text{V}$

Parameter	Symbol	Pins/Remarks	Conditions	Specification				unit
				$V_{DD}[\text{V}]$	min	typ	max	
Operating supply voltage (Note2-1)	$V_{DD}(1)$	$V_{DD1}=V_{DD2}$ $=V_{DD3}=V_{DD4}$	$0.245\mu\text{s} \leq t_{CYC} \leq 200\mu\text{s}$	2.2 to 5.5	2.8		5.5	V
			$0.367\mu\text{s} \leq t_{CYC} \leq 200\mu\text{s}$	2.2 to 5.5	2.5		5.5	
			$1.470\mu\text{s} \leq t_{CYC} \leq 200\mu\text{s}$	2.2 to 5.5	2.2		5.5	
Memory sustaining supply voltage	VHD	$V_{DD1}=V_{DD2}$ $=V_{DD3}=V_{DD4}$	RAM and register contents in HOLD mode.	2.2 to 5.5	2.0		5.5	V
High level input voltage	$V_{IH}(1)$	Ports 1, 2, 3 SI2P0 to SI2P3 P71 to P73 P70 port input/ interrupt side		2.2 to 5.5	$0.3V_{DD}$ $+0.7$		V_{DD}	V
	$V_{IH}(2)$	Ports 0, 8 Ports A, B, C, E, F PWM0, PWM1		2.2 to 5.5	$0.3V_{DD}$ $+0.7$		V_{DD}	
	$V_{IH}(3)$	P70 Watchdog timer side		2.2 to 5.5	$0.9V_{DD}$		V_{DD}	
	$V_{IH}(4)$	XT1, XT2, CF1, RES		2.2 to 5.5	$0.75V_{DD}$		V_{DD}	
Low level input voltage	$V_{IL}(1)$	Ports 1, 2, 3 SI2P0 to SI2P3 P71 to P73 P70 port input/ interrupt		4.0 to 5.5	V_{SS}		$0.1V_{DD}$ $+0.4$	V
				2.2 to 4.0	V_{SS}		$0.2V_{DD}$	
	$V_{IL}(2)$	Ports 0, 8 Ports A, B, C, E, F PWM0, PWM1		2.5 to 5.5	V_{SS}		$0.15V_{DD}$ $+0.4$	
				2.2 to 5.5	V_{SS}		$0.2V_{DD}$	
	$V_{IL}(5)$	Port 70 Watchdog Timer		2.5 to 5.5	V_{SS}		$0.8V_{DD}$ -1.0	
	$V_{IL}(6)$	XT1, XT2, CF1, RES		2.5 to 5.5	V_{SS}		$0.25V_{DD}$	
Instruction cycle time	tCYC (Note2-2)			2.8 to 5.5	0.245		200	μs
				2.5 to 5.5	0.367		200	
				2.2 to 5.5	1.470		200	
External system clock frequency	FEXCF(1)	CF1	<ul style="list-style-type: none"> • CF2 pin open • System clock frequency division rate=1/1 • External system clock duty=50±5% 	2.8 to 5.5	0.1		12	MHz
				2.5 to 5.5	0.1		8	
				2.2 to 5.5	0.1		2	
				2.8 to 5.5	0.2		24.4	
				2.5 to 5.5	0.2		16	
				2.2 to 5.5	0.2		4	
Oscillation frequency Range (Note2-3)	FmCF(1)	CF1, CF2	12MHz ceramic oscillation See Fig. 1.	2.8 to 5.5		12		MHz
	FmCF(2)	CF1, CF2	8MHz ceramic oscillation See Fig. 1.	2.5 to 5.5		8		
	FmCF(3)	CF1, CF2	4MHz ceramic oscillation See Fig. 1.	2.2 to 5.5		4		
	FmRC		Internal RC oscillation	2.2 to 5.5	0.3	1.0	2.0	
	FmMRC		Frequency variable RC oscillation source oscillation	2.2 to 5.5		16		
	FsX'tal	XT1, XT2	32.768kHz crystal oscillation. See Fig. 2.	2.2 to 5.5		32.768		

Note 2-1: V_{DD} must be held greater than or equal to 2.7V in the flash ROM onboard programming mode.

Note 2-2: Relationship between tCYC and oscillation frequency is $3/FmCF$ at a division ratio of 1/1 and $6/FmCF$ at a division ratio of 1/2.

Note 2-3: See Tables 1 and 2 for the oscillation constants.

LC87F5N62B

Electrical Characteristics at Ta = -40°C to +85°C, VSS1 = VSS2 = VSS3 = VSS4 = 0V

Parameter	Symbol	Pins/Remarks	Conditions	Specification				unit
				VDD[V]	min	typ	max	
High level input current	I _{IH} (1)	Ports 0, 1, 2 Ports 3, 7, 8 Ports A, B, C SI2P0 to SI2P3 RES PWM0, PWM1	Output disable Pull-up resistor OFF V _{IN} =V _{DD} (including the off-leak current of the output Tr.)	2.2 to 5.5			1	μA
	I _{IH} (2)	XT1, XT2	Using as an input port V _{IN} =V _{DD}	2.2 to 5.5			1	
	I _{IH} (3)	CF1	V _{IN} =V _{DD}	2.2 to 5.5			15	
Low level input current	I _{IL} (1)	Ports 0, 1, 2 Ports 3, 7, 8 Ports A, B, C, E, F SI2P0 to SI2P3 RES PWM0, PWM1	Output disable Pull-up resistor OFF V _{IN} =V _{SS} (including the off-leak current of the output Tr.)	2.2 to 5.5	-1			μA
	I _{IL} (2)	XT1, XT2	Using as an input port V _{IN} =V _{SS}	2.2 to 5.5	-1			
	I _{IL} (3)	CF1	V _{IN} =V _{SS}	2.2 to 5.5	-15			
High level output voltage	V _{OH} (1)	Ports 0, 1, 2, 3	I _{OH} =-1.0mA	4.5 to 5.5	V _{DD} -1			V
	V _{OH} (2)	Ports A, B, C, E, F SI2P0 to SI2P3	I _{OH} =-0.4mA	3.0 to 5.5	V _{DD} -0.4			
	V _{OH} (3)		I _{OH} =-0.2mA	2.2 to 5.5	V _{DD} -0.4			
	V _{OH} (4)	Ports 71, 72, 73	I _{OH} =-0.4mA	3.0 to 5.5	V _{DD} -0.4			
	V _{OH} (5)		I _{OH} =-0.2mA	2.2 to 5.5	V _{DD} -0.4			
	V _{OH} (6)	PWM0, PWM1	I _{OH} =-10mA	4.5 to 5.5	V _{DD} -1.5			
	V _{OH} (7)	P30, P31(PWM4, 5 output mode)	I _{OH} =-1.6mA	3.0 to 5.5	V _{DD} -0.4			
	V _{OH} (8)		I _{OH} =-1.0mA	2.2 to 5.5	V _{DD} -0.4			
Low level output voltage	V _{OL} (1)	Ports 0, 1, 2, 3	I _{OL} =10mA	4.5 to 5.5			1.5	V
	V _{OL} (2)	Ports A, B, C, E, F SI2P0 to SI2P3	I _{OL} =1.6mA	3.0 to 5.5			0.4	
	V _{OL} (3)	PWM0, PWM1,	I _{OL} =1.0mA	2.2 to 5.5			0.4	
	V _{OL} (4)	P00, P01	I _{OL} =30mA	4.5 to 5.5			1.5	
	V _{OL} (5)		I _{OL} =5.0mA	3.0 to 5.5			0.4	
	V _{OL} (6)		I _{OL} =2.5mA	2.2 to 5.5			0.4	
	V _{OL} (7)	Ports 7, 8, XT2	I _{OL} =1.6mA	3.0 to 5.5			0.4	
	V _{OL} (8)		I _{OL} =1.0mA	2.2 to 5.5			0.4	
Pull-up resitation	Rpu(1)	Ports 0, 1, 2, 3 Port 7	V _{OH} =0.9V _{DD}	4.5 to 5.5	15	35	80	kΩ
	Rpu(2)	Ports A, B, C, E, F		2.2 to 5.5	15	35	120	
Hysteresis voltage	VHYS	RES Ports 1, 2, 7 SI2P0 to SI2P3		2.2to 5.5		0.1V _{DD}		V
Pin capacitance	CP	All pins	<ul style="list-style-type: none"> • For pins other than that under test: V_{IN}=V_{SS} • f=1MHz • Ta=25°C 	2.2 to 5.5		10		pF

LC87F5N62B

Serial I/O Characteristics at Ta = -40°C to +85°C, VSS1 = VSS2 = VSS3 = VSS4 = 0V

1. SIO0 Serial I/O Characteristics (Note 4-1-1)

Parameter	Symbol	Pins /Remarks	Conditions	VDD[V]	Specification					
					min	typ	max	unit		
Serial clock	Input clock	Frequency	tSCK(1)	SCK0(P12)	• See Fig. 6.	2.2 to 5.5	2			tCYC
		Low level pulse width	tSCKL(1)				1			
		High level pulse width	tSCKH(1)				1			
		tSCKHA(1a)	• Continuous data transmission/reception mode • SIO2 is not in use simultaneous. • See Fig. 6. • (Note 4-1-2)	4						
		tSCKHA(1b)		• Continuous data transmission/reception mode • SIO2 is in use simultaneous. • See Fig. 6. • (Note 4-1-2)	6					
	Output clock	Frequency	tSCK(2)		SCK0(P12)	• CMOS output selected. • See Fig. 6.	2.2 to 5.5	4/3		
Low level pulse width		tSCKL(2)	1/2							
High level pulse width		tSCKH(2)	1/2							
		tSCKHA(2a)	• Continuous data transmission/reception mode • SIO2 is not in use simultaneous. • CMOS output selected. • See Fig. 6.	tSCKH(2) +2tCYC					tSCKH(2) +(10/3) tCYC	tCYC
	tSCKHA(2b)	• Continuous data transmission/reception mode • SIO2 is in use simultaneous. • CMOS output selected. • See Fig. 6.		tSCKH(2) +2tCYC		tSCKH(2) +(16/3) tCYC				
Serial input	Data setup time		tsDI(1)	SIO(P11), SB0(P11)	• Must be specified with respect to rising edge of SIOCLK • See fig. 6.	2.2 to 5.5	0.03			
	Data hold time	thDI(1)	0.03							
Serial output	Input clock	Output delay time	tdD0(1)	SO0(P10), SB0(P11),	2.2 to 5.5			(1/3)tCYC +0.05	μs	
			tdD0(2)			• Continuous data transmission/reception mode • (Note 4-1-3)				1tCYC +0.05
	Output clock	tdD0(3)	• Synchronous 8-bit mode. • (Note 4-1-3)					(1/3)tCYC +0.05		
				• (Note 4-1-3)						

Note 4-1-1: These specifications are theoretical values. Add margin depending on its use.

Note 4-1-2: To use serial-clock-input in continuous trans/rec mode, a time from SIORUN being set when serial clock is "H" to the first negative edge of the serial clock must be longer than tSCKHA.

Note 4-1-3: Must be specified with respect to falling edge of SIOCLK. Must be specified as the time to the beginning of output state change in open drain output mode. See Fig. 6.

LC87F5N62B

2. SIO1 Serial I/O Characteristics (Note 4-2-1)

Parameter		Symbol	Pins/ Remarks	Conditions	V _{DD} [V]	Specification				
						min	typ	max	unit	
Serial clock	Input clock	Frequency	tSCK(3)	SCK1(P15)	• See Fig. 6.	2.2 to 5.5	2			tCYC
		Low level pulse width	tSCKL(3)				1			
		High level pulse width	tSCKH(3)				1			
	Output clock	Frequency	tSCK(4)	SCK1(P15)	• CMOS output selected. • See Fig. 6.	2.2 to 5.5	2			tSCK
		Low level pulse width	tSCKL(4)				1/2			
		High level pulse width	tSCKH(4)				1/2			
Serial input	Data setup time	tsDI(2)	SI1(P14), SB1(P14)	• Must be specified with respect to rising edge of SIOCLK • See fig. 6.	2.2 to 5.5	0.03			μs	
	Data hold time	thDI(2)				0.03				
Serial output	Output delay time	tdD0(4)	SO1(P13), SB1(P14)	• Must be specified with respect to falling edge of SIOCLK • Must be specified as the time to the beginning of output state change in open drain output mode. • See Fig. 6.	2.2 to 5.5			(1/3)tCYC +0.05	μs	

Note 4-2-1: These specifications are theoretical values. Add margin depending on its use.

LC87F5N62B

3. SIO2 Serial I/O Characteristics (Note 4-3-1)

Parameter	Symbol	Pins/ Remarks	Conditions	V _{DD} [V]	Specification									
					min.	typ	max.	unit						
Serial clock	Input clock	Frequency	tSCK(5)	SCK2 (SI2P2)	2.2 to 5.5				tCYC					
		Low level pulse width	tSCKL(5)							• See Fig. 6.	2			
		High level pulse width	tSCKH(5)							• Continuous data transmission/reception mode of SIO0 is not in use simultaneous. • See Fig. 6. • (Note 4-3-2)	1			
			tSCKHA(5a)								1			
	Output clock	Frequency	tSCK(6)	SCK2 (SI2P2), SCK2O (SI2P3)		2.2 to 5.5					tSCK			
			Low level pulse width									tSCKL(6)	• CMOS output selected. • See Fig. 6.	4/3
		High level pulse width	tSCKH(6)									• Continuous data transmission/reception mode of SIO0 is not in use simultaneous. • CMOS output selected. • See Fig. 6.	1/2	
			tSCKHA(6a)										1/2	
Serial input	Data setup time	tsDI(3)	SI2(SI2P1), SB2(SI2P1)	2.2 to 5.5				μs						
	Data hold Time	thDI(3)							• Must be specified with respect to rising edge of SIOCLK • See fig. 6.	0.03				
Serial output	Output delay time	tdD0(5)	SO2 (SI2P0), SB2(SI2P1)	2.2 to 5.5				μs						
									• Must be specified with respect to falling edge of SIOCLK • Must be specified as the time to the beginning of output state change in open drain output mode. • See Fig. 6.	(1/3)tCYC +0.05				

Note 4-3-1: These specifications are theoretical values. Add margin depending on its use.

Note 4-3-2: To use serial-clock-input, a time from SI2RUN being set when serial clock is "H" to the first negative edge of the serial clock must be longer than tSCKHA.

LC87F5N62B

Pulse Input Conditions at Ta = -40°C to +85°C, VSS1 = VSS2 = VSS3 = VSS4 = 0V

Parameter	Symbol	Pins/Remarks	Conditions	Specification				
				VDD[V]	min	typ	max	unit
High/low level pulse width	tPIH(1) tPIL(1)	INT0(P70), INT1(P71), INT2(P72) INT4(P20 to P23), INT5(P24 to P27), INT6(P20) INT7(P24)	<ul style="list-style-type: none"> Interrupt source flag can be set. Event inputs for timer 0 or 1 are enabled. 	2.2 to 5.5	1			tCYC
	tPIH(2) tPIL(2)	INT3(P73) when noise filter time constant is 1/1.	<ul style="list-style-type: none"> Interrupt source flag can be set. Event inputs for timer 0 are enabled. 	2.2 to 5.5	2			
	tPIH(3) tPIL(3)	INT3(P73)(The noise rejection clock is selected to 1/32.)	<ul style="list-style-type: none"> Interrupt source flag can be set. Event inputs for timer 0 are enabled. 	2.2 to 5.5	64			
	tPIH(4) tPIL(4)	INT3(P73)(The noise rejection clock is selected to 1/128.)	<ul style="list-style-type: none"> Interrupt source flag can be set. Event inputs for timer 0 are enabled. 	2.2 to 5.5	256			
	tPIL(5)	$\overline{\text{RES}}$	Reset acceptable.	2.2 to 5.5	200			

AD Converter Characteristics at Ta = -40°C to +85°C, VSS1 = VSS2 = VSS3 = VSS4 = 0V

Parameter	Symbol	Pins/Remarks	Conditions	Specification				
				VDD[V]	min	typ	max	unit
Resolution	N	AN0(P80) to		3.0 to 5.5		8		bit
Absolute accuracy	ET	AN7(P87), AN8(P70),	(Note 6-1)	3.0 to 5.5			±1.5	LSB
Conversion time	TCAD	AN9(P71), AN10(XT1), AN11(XT2), AN12(PA3), AN13(PA4), AN14(PA5)	AD conversion time=32×tCYC (when ADCR2=0) (Note 6-2)	4.5 to 5.5	11.74 (tCYC= 0.367μs)		97.92 (tCYC= 3.06μs)	μs
				3.0 to 5.5	23.53 (tCYC= 0.735μs)		97.92 (tCYC= 3.06μs)	
			AD conversion time=64×tCYC (when ADCR2=1) (Note 6-2)	4.5 to 5.5	15.68 (tCYC= 0.245μs)		97.92 (tCYC= 1.53μs)	
				3.0 to 5.5	23.49 (tCYC= 0.367μs)		97.92 (tCYC= 1.53μs)	
Analog input voltage range	VAIN			3.0 to 5.5	VSS		VDD	V
Analog port input current	IAINH		VAIN=VDD	3.0 to 5.5			1	μA
	IAINL		VAIN=VSS	3.0 to 5.5	-1			

Note 6-1: The quantization error (±1/2 LSB) is excluded from the absolute accuracy value.

Note 6-2: The conversion time refers to the interval from the time the instruction for starting the converter is issued till the complete digital value corresponding to the analog input value is loaded in the required register.

LC87F5N62B

Consumption Current Characteristics at Ta = -40°C to +85°C, VSS1 = VSS2 = VSS3 = VSS4 = 0V

Parameter	Symbol	Pins/Remarks	Conditions	Specification				
				V _{DD} [V]	min	typ	max	unit
Normal mode consumption current (Note 7-1)	IDDOP(1)	V _{DD1} =V _{DD2} =V _{DD3} =V _{DD4}	<ul style="list-style-type: none"> FmCF=12MHz ceramic oscillation mode FmX'tal=32.768kHz by crystal oscillation mode System clock set to 12MHz side Internal RC oscillation stopped frequency variable RC oscillation stopped 1/1 frequency division ratio. 	4.5 to 5.5		9.3	20.5	mA
			<ul style="list-style-type: none"> System clock set to 12MHz side Internal RC oscillation stopped frequency variable RC oscillation stopped 1/1 frequency division ratio. 	2.8 to 4.5		5.4	14.8	
	<ul style="list-style-type: none"> FmCF=8MHz ceramic oscillation mode FmX'tal=32.768kHz by crystal oscillation mode System clock set to 8MHz side Internal RC oscillation stopped frequency variable RC oscillation stopped 1/1 frequency division ratio. 		4.5 to 5.5		6.9	15.5		
	<ul style="list-style-type: none"> System clock set to 8MHz side Internal RC oscillation stopped frequency variable RC oscillation stopped 1/1 frequency division ratio. 		2.5 to 4.5		3.9	11		
	<ul style="list-style-type: none"> FmCF=4MHz ceramic oscillation mode FmX'tal=32.768kHz by crystal oscillation mode System clock set to 4MHz side Internal RC oscillation stopped frequency variable RC oscillation stopped 1/1 frequency division ratio. 		4.5 to 5.5		2.75	6.6		
	<ul style="list-style-type: none"> System clock set to 4MHz side Internal RC oscillation stopped frequency variable RC oscillation stopped 1/1 frequency division ratio. 		2.2 to 4.5		1.45	4.2		
	<ul style="list-style-type: none"> FmCF=0Hz (oscillation stopped) FmX'tal=32.768kHz by crystal oscillation mode System clock set to internal RC oscillation frequency variable RC oscillation stopped 1/2 frequency division ratio. 		4.5 to 5.5		1	4.8		
	<ul style="list-style-type: none"> System clock set to internal RC oscillation frequency variable RC oscillation stopped 1/2 frequency division ratio. 		2.2 to 4.5		0.55	3.3		
	<ul style="list-style-type: none"> FmCF=0Hz (oscillation stopped) FmX'tal=32.768kHz by crystal oscillation mode. System clock set to 1MHz with frequency variable RC oscillation Internal RC oscillation stopped 1/2 frequency division ratio. 		4.5 to 5.5		1.3	5.7		
	<ul style="list-style-type: none"> System clock set to 1MHz with frequency variable RC oscillation Internal RC oscillation stopped 1/2 frequency division ratio. 		2.2 to 4.5		0.7	4.6		
	IDDOP(10)		<ul style="list-style-type: none"> FmCF=0Hz (oscillation stopped) FmX'tal=32.768kHz by crystal oscillation mode. System clock set to 32.768kHz side. Internal RC oscillation stopped frequency variable RC oscillation stopped 1/2 frequency division ratio. 	4.5 to 5.5		40	120	μA
IDDOP(11)	<ul style="list-style-type: none"> System clock set to 32.768kHz side. Internal RC oscillation stopped frequency variable RC oscillation stopped 1/2 frequency division ratio. 	2.2 to 4.5		20	77			
HALT mode consumption current (Note 7-1)	IDDHALT(1)	V _{DD1} =V _{DD2} =V _{DD3} =V _{DD4}	<ul style="list-style-type: none"> HALT mode FmCF=12MHz ceramic oscillation mode FmX'tal=32.768kHz by crystal oscillation mode System clock set to 12MHz side Internal RC oscillation stopped frequency variable RC oscillation stopped 1/1 frequency division ratio. 	4.5 to 5.5		3.6	8.3	mA
			<ul style="list-style-type: none"> System clock set to 12MHz side Internal RC oscillation stopped frequency variable RC oscillation stopped 1/1 frequency division ratio. 	2.8 to 5.5		2.1	4.4	
	<ul style="list-style-type: none"> HALT mode FmCF=8MHz ceramic oscillation mode FmX'tal=32.768kHz by crystal oscillation mode System clock set to 8MHz side Internal RC oscillation stopped frequency variable RC oscillation stopped 1/1 frequency division ratio. 		4.5 to 5.5		2.7	5.8		
IDDHALT(3)	<ul style="list-style-type: none"> System clock set to 8MHz side Internal RC oscillation stopped frequency variable RC oscillation stopped 1/1 frequency division ratio. 	2.5 to 4.5		1.4	3.1			

Note 7-1: The consumption current value includes none of the currents that flow into the output Tr and internal pull-up resistors

Continued on next page.

LC87F5N62B

Continued from preceding page.

Parameter	Symbol	Pins/Remarks	Conditions	Specification				
				V _{DD} [V]	min	typ	max	unit
HALT mode consumption current (Note 7-1)	IDDHALT(4)	V _{DD1} =V _{DD2} =V _{DD3} =V _{DD4}	<ul style="list-style-type: none"> • HALT mode • FmCF=4MHz ceramic oscillation mode • FmX'tal=32.768kHz by crystal oscillation mode 	4.5 to 5.5		1.1	2.6	mA
	IDDHALT(5)		<ul style="list-style-type: none"> • System clock set to 4MHz side • Internal RC oscillation stopped • frequency variable RC oscillation stopped • 1/1 frequency division ratio. 	2.2 to 4.5		0.57	1.5	
	IDDHALT(6)		<ul style="list-style-type: none"> • HALT mode • FmCF=0Hz (oscillation stopped) • FmX'tal=32.768kHz by crystal oscillation mode 	4.5 to 5.5		0.38	1.0	
	IDDHALT(7)		<ul style="list-style-type: none"> • System clock set to internal RC oscillation • frequency variable RC oscillation stopped • 1/2 frequency division ratio. 	2.2 to 4.5		0.19	0.8	
	IDDHALT(8)		<ul style="list-style-type: none"> • HALT mode • FmCF=0Hz (oscillation stopped) • FmX'tal=32.768kHz by crystal oscillation mode. 	4.5 to 5.5		1.15	4.2	
	IDDHALT(9)		<ul style="list-style-type: none"> • System clock set to 1MHz with frequency variable RC oscillation • Internal RC oscillation stopped • 1/2 frequency division ratio. 	2.2 to 4.5		0.57	3.0	
	IDDHALT(10)		<ul style="list-style-type: none"> • HALT mode • FmCF=0Hz (oscillation stopped) • FmX'tal=32.768kHz by crystal oscillation mode. 	4.5 to 5.5		20	77	
	IDDHALT(11)	<ul style="list-style-type: none"> • System clock set to 32.768kHz side. • Internal RC oscillation stopped • frequency variable RC oscillation stopped • 1/2 frequency division ratio. 	2.2 to 4.5		6	70	μA	
HOLD mode consumption current	IDDHOLD(1)	V _{DD1}	<ul style="list-style-type: none"> • HOLD mode • CF1=V_{DD} or open (External clock mode) 	4.5 to 5.5		0.04	19	μA
	IDDHOLD(2)		<ul style="list-style-type: none"> • CF1=V_{DD} or open (External clock mode) 	2.2 to 4.5		0.02	14	
Timer HOLD mode consumption current	IDDHOLD(3)		<ul style="list-style-type: none"> • Timer HOLD mode • CF1=V_{DD} or open (External clock mode) 	4.5 to 5.5		17	70	
	IDDHOLD(4)		<ul style="list-style-type: none"> • FmX'tal=32.768kHz by crystal oscillation mode 	2.2 to 4.5		4	55	

Note 7-1: The consumption current value includes none of the currents that flow into the output Tr and internal pull-up resistors

F-ROM Programming Characteristics at Ta = +10°C to +55°C, V_{SS1} = V_{SS2} = V_{SS3} = V_{SS4} = 0V

Parameter	Symbol	Pins/Remarks	Conditions	Specification				
				V _{DD} [V]	min	typ	max	unit
Onboard programming current	IDDFW(1)	V _{DD1}	<ul style="list-style-type: none"> • Without CPU current 	2.7 to 5.5		5	10	mA
Programming time	tFW(1)		<ul style="list-style-type: none"> • Erasing 	2.7 to 5.5		20	30	ms
	tFW(2)		<ul style="list-style-type: none"> • programming 	2.7 to 5.5		40	60	μs

LC87F5N62B

UART (Full Duplex) Operating Conditions at $T_a = -40^{\circ}\text{C}$ to $+85^{\circ}\text{C}$, $V_{SS1} = V_{SS2} = V_{SS3} = V_{SS4} = 0\text{V}$

Parameter	Symbol	Pins/Remarks	Conditions	Specification				
				$V_{DD}[\text{V}]$	min	typ	max	unit
Transfer rate	UBR, UBR2	UTX1(P32), RTX1(P33), UTX2(P33), RTX2(P34)		2.5 to 5.5	16/3		8192/3	tCYC

Data length : 7/8/9 bits (LSB first)

Stop bits : 1-bit (2-bit in continuous data transmission)

Parity bits : None

Example of Continuous 8-bit Data Transmission Mode Processing (First Transmit Data = 55H)

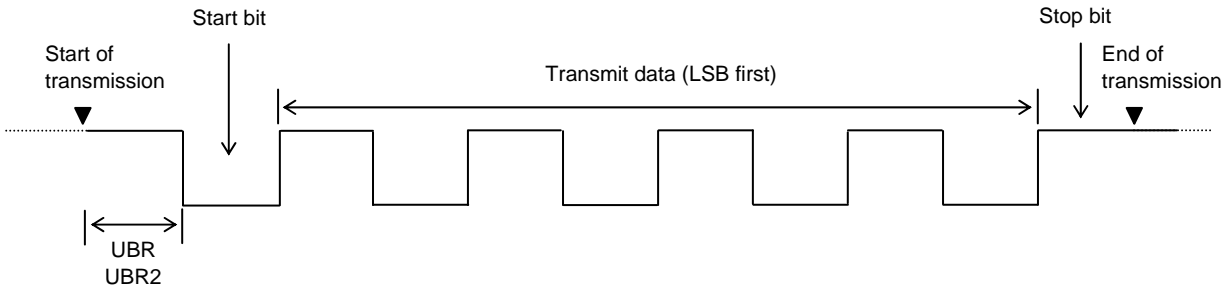

Example of Continuous 8-bit Data Reception Mode Processing (First Receive Data = 55H)

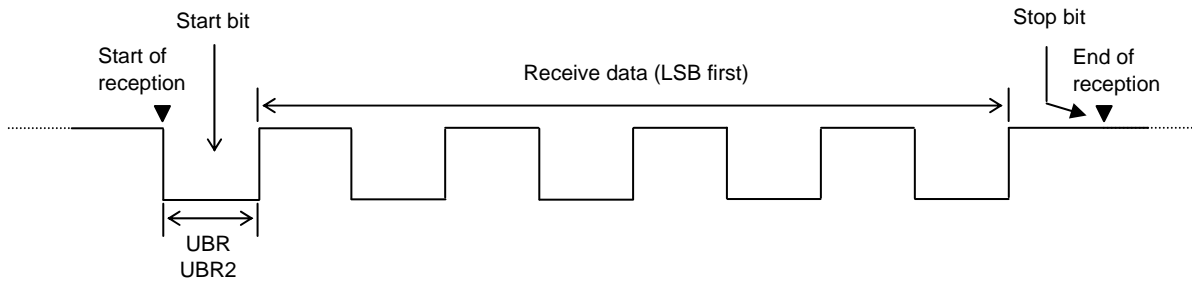

VDD1, VSS1 Terminal Condition

It is necessary to place capacitors between V_{DD1} and V_{SS1} as describe below.

- Place capacitors as close to V_{DD1} and V_{SS1} as possible.
- Place capacitors so that the length of each terminal to the each leg of the capacitor be equal ($L_1 = L_1'$, $L_2 = L_2'$).
- Place high capacitance capacitor C_1 and low capacitance capacitor C_2 in parallel.
- Capacitance of C_2 must be more than $0.1\mu\text{F}$.
- Use thicker pattern for V_{DD1} and V_{SS1} .

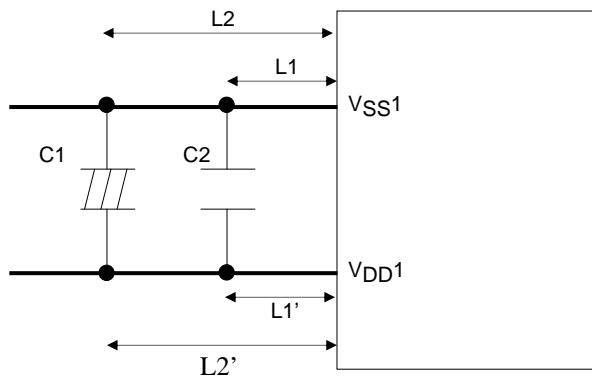

Characteristics of a Sample Main System Clock Oscillation Circuit

Given below are the characteristics of a sample main system clock oscillation circuit that are measured using a Our designated oscillation characteristics evaluation board and external components with circuit constant values with which the oscillator vendor confirmed normal and stable oscillation.

Table 1 Characteristics of a Sample Main System Clock Oscillator Circuit with a Ceramic Oscillator

Nominal Frequency	Vendor Name	Oscillator Name	Circuit Constant				Operating Voltage Range [V]	Oscillation Stabilization Time		Remarks
			C1 [pF]	C2 [pF]	Rf1 [Ω]	Rd1 [Ω]		typ [ms]	max [ms]	
12MHz	MURATA	CSTCE12M0G52-R0	(10)	(10)	Open	470	2.5 to 5.5	0.03	0.5	Internal C1,C2
10MHz		CSTCE10M0G52-R0	(10)	(10)	Open	680	2.4 to 5.5	0.03	0.5	Internal C1,C2
		CSTLS10M0G53-B0	(15)	(15)	Open	680	2.5 to 5.5	0.03	0.5	Internal C1,C2
8MHz		CSTSE8M00G52-R0	(10)	(10)	Open	1k	2.3 to 5.5	0.03	0.5	Internal C1,C2
		CSTLS8M00G53-B0	(15)	(15)	Open	1k	2.5 to 5.5	0.03	0.5	Internal C1,C2
4MHz		CSTCR4M00G53-R0	(15)	(15)	Open	1.5k	2.2 to 5.5	0.03	0.5	Internal C1,C2
		CSTLS4M00G53-B0	(15)	(15)	Open	1.5k	2.2 to 5.5	0.03	0.5	Internal C1,C2

The oscillation stabilization time refers to the time interval that is required for the oscillation to get stabilized after V_{DD} goes above the operating voltage lower limit (see Fig. 4).

Characteristics of a Sample Subsystem Clock Oscillator Circuit

Given below are the characteristics of a sample subsystem clock oscillation circuit that are measured using a Our designated oscillation characteristics evaluation board and external components with circuit constant values with which the oscillator vendor confirmed normal and stable oscillation.

Table 2 Characteristics of a Sample Subsystem Clock Oscillator Circuit with a Crystal Oscillator

Nominal Frequency	Vendor Name	Oscillator Name	Circuit Constant				Operating Voltage Range [V]	Oscillation Stabilization Time		Remarks
			C3 [pF]	C4 [pF]	Rf2 [Ω]	Rd2 [Ω]		typ [s]	max [s]	
32.768kHz	EPSON TOYOCOM	MC-306	18	18	Open	560k	2.2 to 5.5	1.5	3.0	Applicable CL value=12.5pF

The oscillation stabilization time refers to the time interval that is required for the oscillation to get stabilized after the instruction for starting the subclock oscillation circuit is executed and to the time interval that is required for the oscillation to get stabilized after the HOLD mode is reset (see Figure. 4).

Note: The components that are involved in oscillation should be placed as close to the IC and to one another as possible because they are vulnerable to the influences of the circuit pattern.

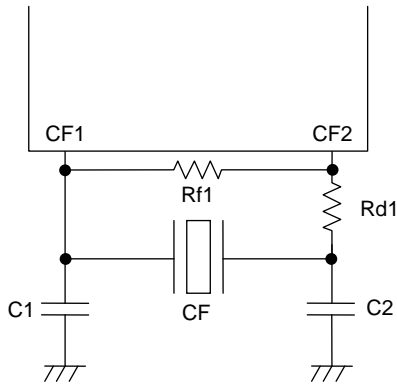

Figure 1 Ceramic Oscillator Circuit

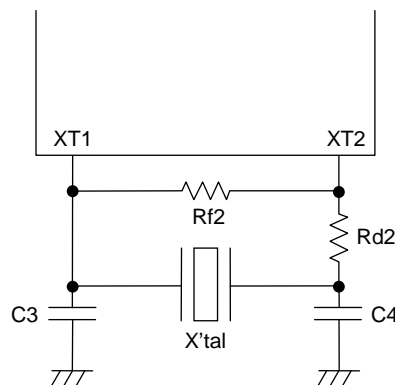

Figure 2 Crystal Oscillator Circuit

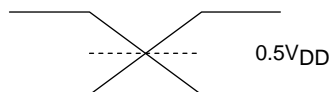
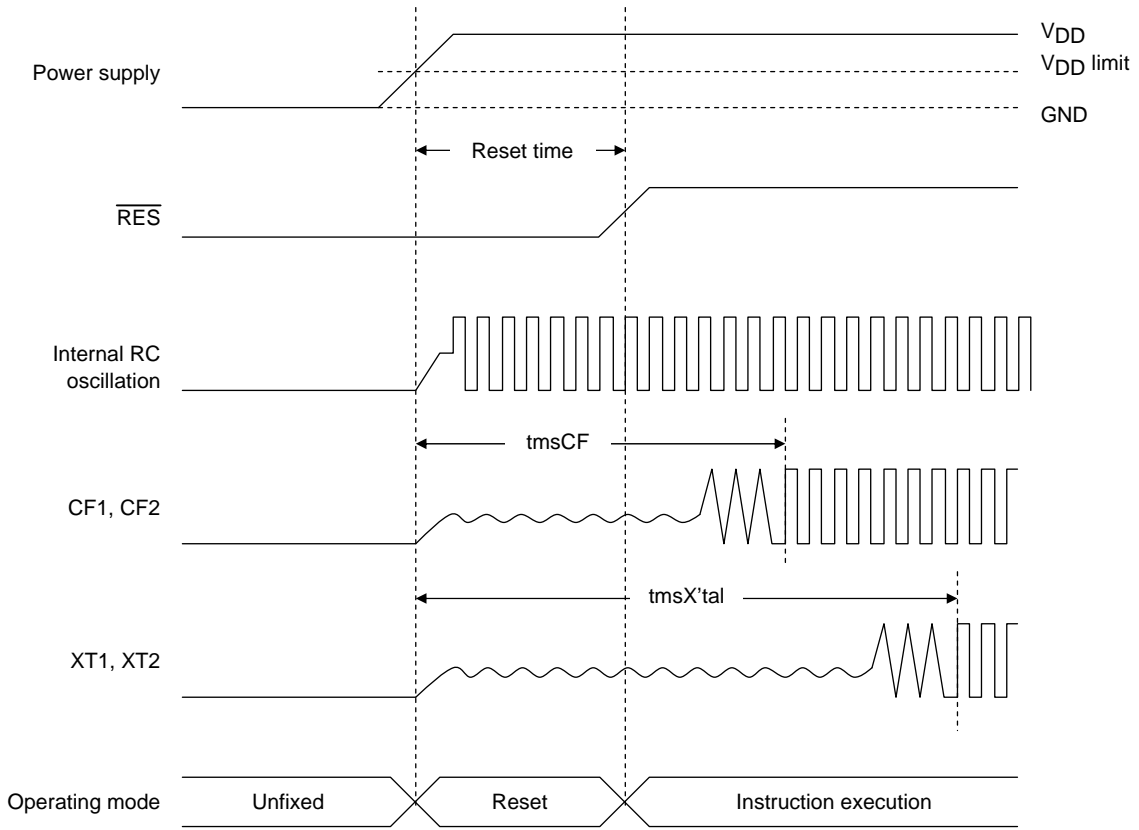
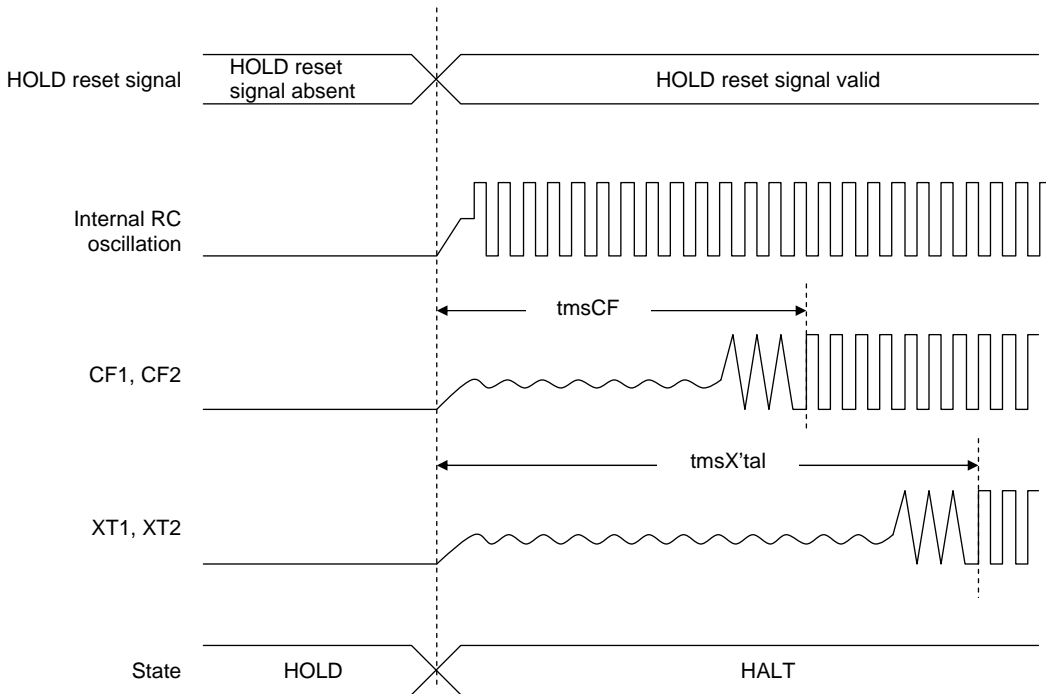

Figure 3 AC Timing Measurement Point

LC87F5N62B



Reset Time and Oscillation Stabilization Time



HOLD Release Signal and Oscillation Stabilization Time

Figure 4 Oscillation Stabilization Times

LC87F5N62B

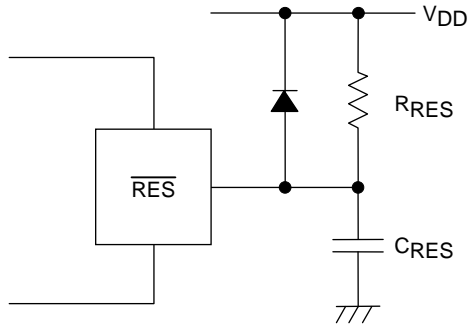

Note:
 Select C_{RES} and R_{RES} value to assure that at least $200\mu s$ reset time is generated after the V_{DD} becomes higher than the minimum operating voltage.

Figure 5 Reset Circuit

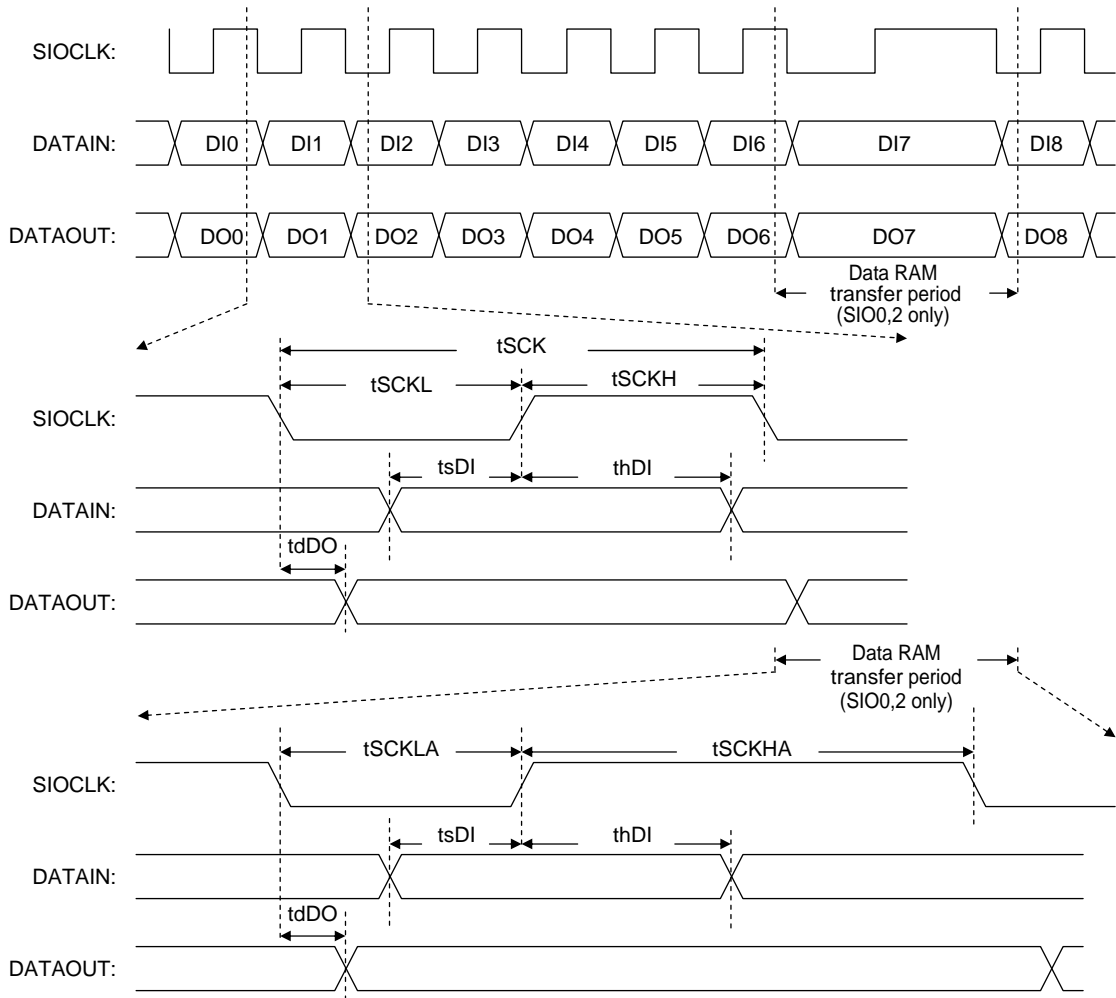

Figure 6 Serial I/O Waveforms

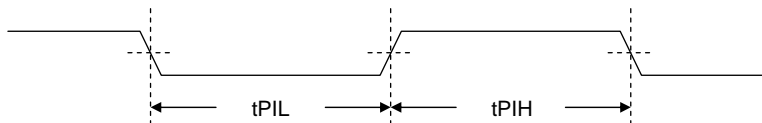

Figure 7 Pulse Input Timing Signal Waveform

ON Semiconductor and the ON logo are registered trademarks of Semiconductor Components Industries, LLC (SCILLC). SCILLC owns the rights to a number of patents, trademarks, copyrights, trade secrets, and other intellectual property. A listing of SCILLC's product/patent coverage may be accessed at www.onsemi.com/site/pdf/Patent-Marking.pdf. SCILLC reserves the right to make changes without further notice to any products herein. SCILLC makes no warranty, representation or guarantee regarding the suitability of its products for any particular purpose, nor does SCILLC assume any liability arising out of the application or use of any product or circuit, and specifically disclaims any and all liability, including without limitation special, consequential or incidental damages. "Typical" parameters which may be provided in SCILLC data sheets and/or specifications can and do vary in different applications and actual performance may vary over time. All operating parameters, including "Typicals" must be validated for each customer application by customer's technical experts. SCILLC does not convey any license under its patent rights nor the rights of others. SCILLC products are not designed, intended, or authorized for use as components in systems intended for surgical implant into the body, or other applications intended to support or sustain life, or for any other application in which the failure of the SCILLC product could create a situation where personal injury or death may occur. Should Buyer purchase or use SCILLC products for any such unintended or unauthorized application, Buyer shall indemnify and hold SCILLC and its officers, employees, subsidiaries, affiliates, and distributors harmless against all claims, costs, damages, and expenses, and reasonable attorney fees arising out of, directly or indirectly, any claim of personal injury or death associated with such unintended or unauthorized use, even if such claim alleges that SCILLC was negligent regarding the design or manufacture of the part. SCILLC is an Equal Opportunity/Affirmative Action Employer. This literature is subject to all applicable copyright laws and is not for resale in any manner.

Looking for pricing, stock, or lifecycle information?

Click below to explore more details on WIN SOURCE:

- ⊖ [View LC87F5N62B](#) on WIN SOURCE
- ⊖ [ON Semiconductor](#) Information

Optimize Your Supply Chain with WIN SOURCE Solutions

- ✓ Global Sourcing Solution
- ✓ Obsolete Management
- ✓ Cost Control Management
- ✓ Shortage Management
- ✓ Alternative Solution
- ✓ Excess Inventory Management