



**THE DATASHEET OF
LC75836WS-E**



LC75836W

1/4-Duty General-Purpose LCD Driver



ON Semiconductor®

www.onsemi.com

Overview

The LC75836W is 1/4-duty general-purpose microprocessor-controlled LCD driver that can be used in applications such as frequency display in products with electronic tuning. In addition to being able to drive up to 140 segments directly, the LC75836W can also control up to 4 general-purpose output ports.

Features

- 1/4 duty, 1/3 bias drive (Up to 140 segment can be displayed.)
- Serial data input supports CCB* format communication with the system controller (support 3 V operation).
- Serial data control of the power-saving mode based backup function and the all segments forced off function.
- Serial data control of switching between the segment output port and general-purpose output port functions.
- Serial data control of the frame frequency of the common and segment output waveforms.
- Either RC oscillator operating or external clock operating mode can be selected with the serial control data.
- High generality, since display data is displayed directly without the intervention of a decoder circuit.
- The $\overline{\text{INH}}$ pin allows the display to be forced to the off state.
- RC oscillation circuit (with external resistor and capacitor)

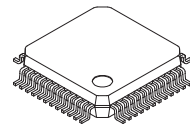

SPQFP48 7x7 / SQFP48

* Computer Control Bus (CCB) is an ON Semiconductor's original bus format and the bus addresses are controlled by ON Semiconductor.

ORDERING INFORMATION

See detailed ordering and shipping information on page 17 of this data sheet.

LC75836W

Specifications

Absolute Maximum Ratings at Ta = 25°C, VSS = 0 V

Parameter	Symbol	Conditions	Ratings	Unit
Maximum supply voltage	VDD max	VDD	-0.3 to +7.0	V
Input voltage	VIN1	CE, CL, DI, $\overline{\text{INH}}$	-0.3 to +7.0	V
	VIN2	OSC, VDD1, VDD2	-0.3 to VDD+0.3	
Output voltage	VOUT	S1 to S35, COM1 to COM4, P1 to P4, OSC	-0.3 to VDD+0.3	V
Output current	IOUT1	S1 to S35	300	μA
	IOUT2	COM1 to COM4	3	mA
	IOUT3	P1 to P4	5	
Allowable power dissipation	Pdmax	Ta = 85°C	100	mW
Operating temperature	Topr		-40 to +85	°C
Storage temperature	Tstg		-55 to +125	°C

Stresses exceeding those listed in the Maximum Ratings table may damage the device. If any of these limits are exceeded, device functionality should not be assumed, damage may occur and reliability may be affected.

Allowable Operating Ranges at Ta = -40 to +85°C, VSS = 0 V

Parameter	Symbol	Conditions	Ratings			Unit
			min	typ	max	
Supply voltage	VDD	VDD	4.5		6.0	V
Input voltage	VDD1	VDD1		2/3VDD	VDD	V
	VDD2	VDD2		1/3VDD	VDD	
Input high-level voltage	VIH1	CE, CL, DI, $\overline{\text{INH}}$	0.4VDD		6.0	V
	VIH2	OSC external clock operating mode	0.4VDD		VDD	
Input low-level voltage	VIL1	CE, CL, DI, $\overline{\text{INH}}$	0		0.2VDD	V
	VIL2	OSC external clock operating mode	0		0.2VDD	
Recommended external resistor for RC oscillation	Rosc	OSC RC oscillator operating mode		39		kΩ
Recommended external capacitor for RC oscillation	Cosc	OSC RC oscillator operating mode		1000		pF
Guaranteed range of RC oscillation	fosc	OSC RC oscillator operating mode	19	38	76	kHz
External clock operating frequency	fCK	OSC external clock operating mode [Figure 4]	19	38	76	kHz
External clock duty cycle	DCK	OSC external clock operating mode [Figure 4]	30	50	70	%
Data setup time	tds	CL, DI [Figure 2] [Figure 3]	160			ns
Data hold time	tdh	CL, DI [Figure 2] [Figure 3]	160			ns
CE wait time	tcp	CE, CL [Figure 2] [Figure 3]	160			ns
CE setup time	tcs	CE, CL [Figure 2] [Figure 3]	160			ns
CE hold time	tch	CE, CL [Figure 2] [Figure 3]	160			ns
High-level clock pulse width	tφH	CL [Figure 2] [Figure 3]	160			ns
Low-level clock pulse width	tφL	CL [Figure 2] [Figure 3]	160			ns
Rise time	tr	CE, CL, DI [Figure 2] [Figure 3]		160		ns
Fall time	tf	CE, CL, DI [Figure 2] [Figure 3]		160		ns
$\overline{\text{INH}}$ switching time	tc	$\overline{\text{INH}}$, CE [Figure 5]	10			μs

Functional operation above the stresses listed in the Recommended Operating Ranges is not implied. Extended exposure to stresses beyond the Recommended Operating Ranges limits may affect device reliability.

LC75836W

Electrical Characteristics for the Allowable Operating Ranges

Parameter	Symbol	Pin	Conditions	Ratings			Unit
				min	typ	max	
Hysteresis	V_H	CE, CL, DI, \overline{INH}			0.03 V_{DD}		V
Input high-level current	I_{IH1}	CE, CL, DI, \overline{INH}	$V_I = 6.0$ V			5.0	μ A
	I_{IH2}	OSC	$V_I = V_{DD}$ external clock operating mode			5.0	
Input low-level current	I_{IL1}	CE, CL, DI, \overline{INH}	$V_I = 0$ V	-5.0			μ A
	I_{IL2}	OSC	$V_I = 0$ V external clock operating mode	-5.0			
Output high-level voltage	V_{OH1}	S1 to S35	$I_O = -20$ μ A	$V_{DD}-0.9$			V
	V_{OH2}	COM1 to COM4	$I_O = -100$ μ A	$V_{DD}-0.9$			
	V_{OH3}	P1 to P4	$I_O = -1$ mA	$V_{DD}-0.9$			
Output low-level voltage	V_{OL1}	S1 to S35	$I_O = 20$ μ A			0.9	V
	V_{OL2}	COM1 to COM4	$I_O = 100$ μ A			0.9	
	V_{OL3}	P1 to P4	$I_O = 1$ mA			0.9	
Output middle-level voltage *1	V_{MID1}	S1 to S35	1/3 bias $I_O = \pm 20$ μ A	$2/3V_{DD}-0.9$		$2/3V_{DD}+0.9$	V
	V_{MID2}	S1 to S35	1/3 bias $I_O = \pm 20$ μ A	$1/3V_{DD}-0.9$		$1/3V_{DD}+0.9$	
	V_{MID3}	COM1 to COM4	1/3 bias $I_O = \pm 100$ μ A	$2/3V_{DD}-0.9$		$2/3V_{DD}+0.9$	
	V_{MID4}	COM1 to COM4	1/3 bias $I_O = \pm 100$ μ A	$1/3V_{DD}-0.9$		$1/3V_{DD}+0.9$	
Oscillator frequency	fosc	OSC	RC oscillator operating mode $R_{osc} = 39$ k Ω , $C_{osc} = 1000$ pF	30.4	38	45.6	kHz
Current drain	I_{DD1}	V_{DD}	Power-saving mode			5	μ A
	I_{DD2}	V_{DD}	$V_{DD} = 6.0$ V output open RC oscillator operating mode fosc = 38 kHz		350	700	
	I_{DD3}	V_{DD}	$V_{DD} = 6.0$ V output open External clock operating mode f _{CK} = 38 kHz $V_{IH2} = 0.5V_{DD}$ $V_{IL2} = 0.1V_{DD}$		450	900	

Note: *1 Excluding the bias voltage generation divider resistors built in the V_{DD1} and V_{DD2} . (See Figure 1.)

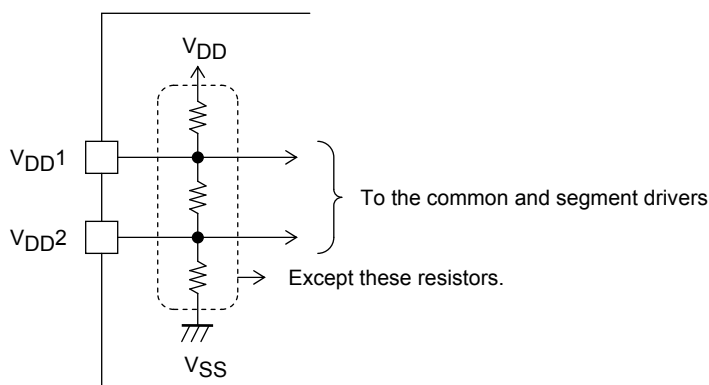

Figure 1

Product parametric performance is indicated in the Electrical Characteristics for the listed test conditions, unless otherwise noted. Product performance may not be indicated by the Electrical Characteristics if operated under different conditions.

LC75836W

1. When CL is stopped at the low level

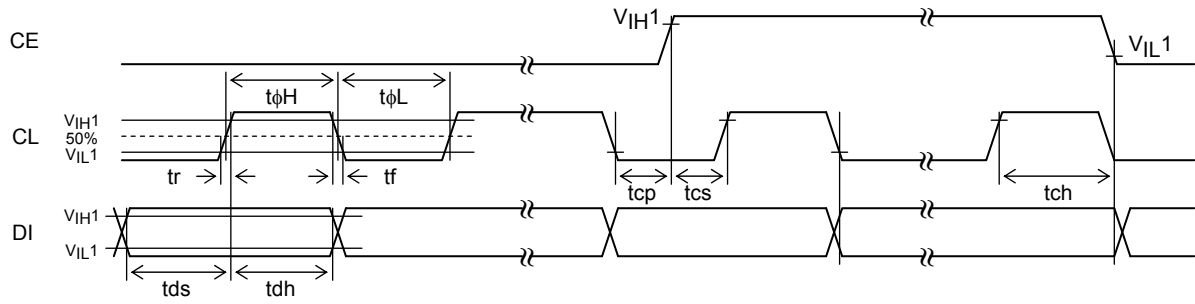

Figure 2

2. When CL is stopped at the high level

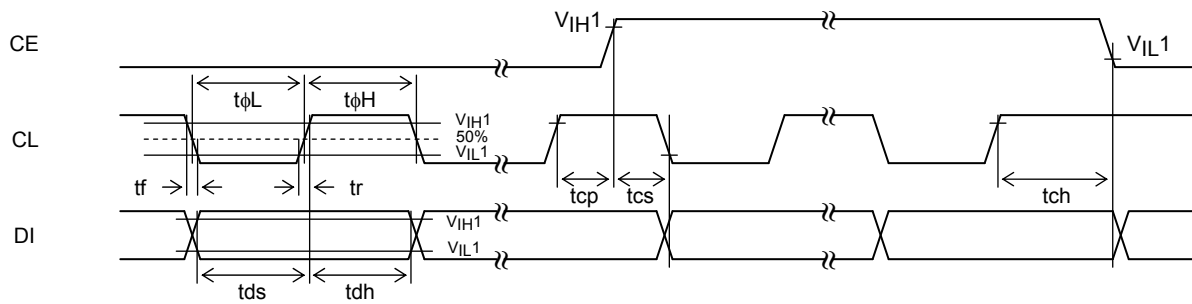

Figure 3

3. OSC pin clock timing in external clock operating mode

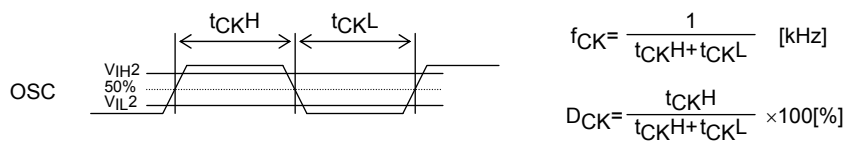

Figure 4

LC75836W

Package Dimensions

unit : mm

SPQFP48 7x7 / SQFP48
CASE 131AJ
ISSUE A

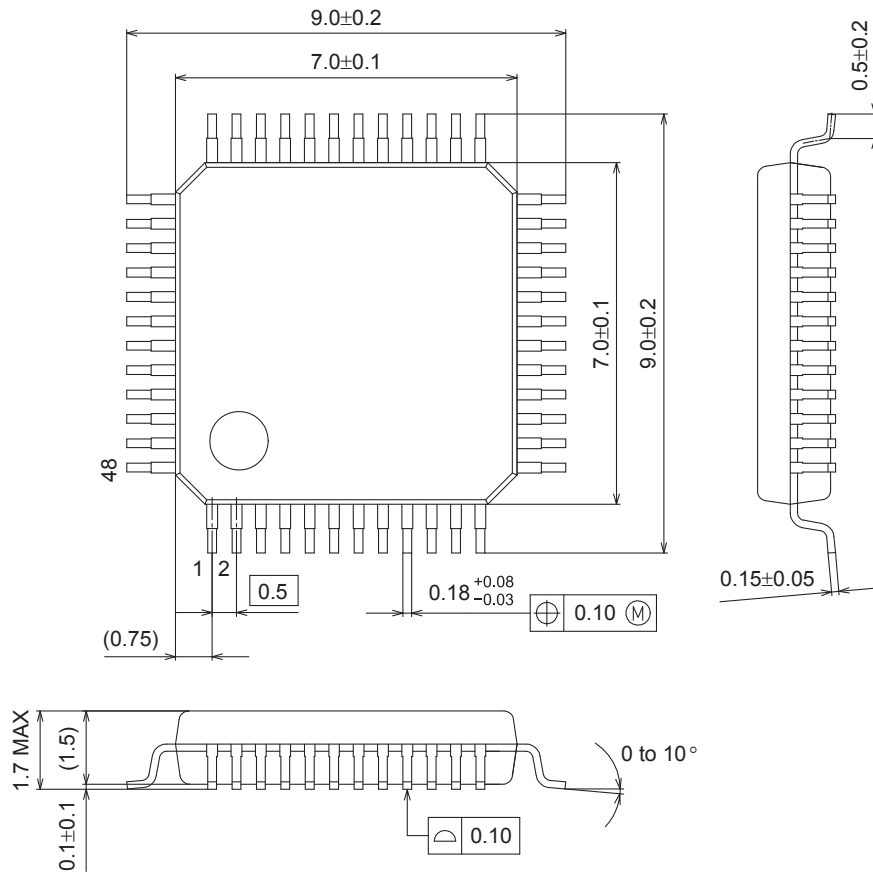

SOLDERING FOOTPRINT*

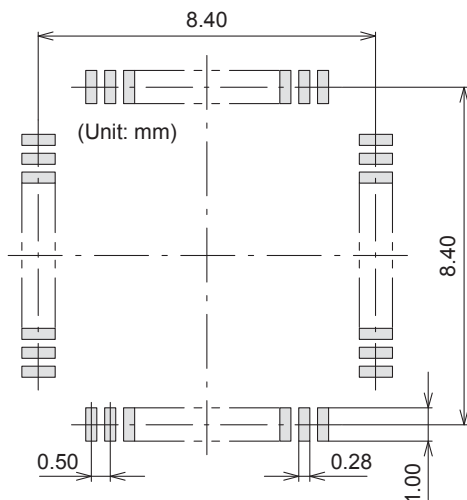

GENERIC MARKING DIAGRAM*

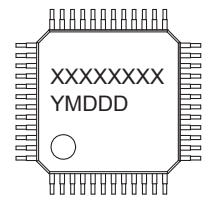
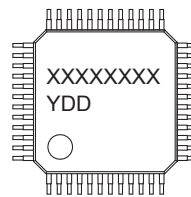

XXXXXX = Specific Device Code
Y = Year
DD = Additional Traceability Data

XXXXXX = Specific Device Code
Y = Year
M = Month
DDD = Additional Traceability Data

*This information is generic.
Pb-Free indicator, "G" or microdot "▪",
may or may not be present.

NOTE: The measurements are not to guarantee but for reference only.

*For additional information on our Pb-Free strategy and soldering details, please download the ON Semiconductor Soldering and Mounting Techniques Reference Manual, SOLDERM/D.

LC75836W

Pin Functions

Symbol	Pin No.	Function	Active	I/O	Handling when unused
S1/P1 to S4/P4 S5 to S34 S35	1 to 4 5 to 34 39	Segment outputs for displaying the display data transferred by serial data input. The S1/P1 to S4/P4 pins can be used as general-purpose output ports when so set up by the control data.	-	O	OPEN
COM1 to COM4	35 to 38	Common driver outputs. The frame frequency is fo [Hz].	-	O	OPEN
OSC	44	Oscillator connection. An oscillator circuit is formed by connecting an external resistor and capacitor to this pin. This pin can be used as the external clock input pin if external clock operating mode is selected with the control data.	-	I/O	V _{DD}
CE CL DI	46 47 48	Serial data transfer inputs. Must be connected to the controller. CE: Chip enable CL: Synchronization clock DI: Transfer data	H  -	I I I	GND
$\overline{\text{INH}}$	45	Display off control input • $\overline{\text{INH}}$ = low (V _{SS}) ...Display forced off S1/P1 to S4/P4 = low (V _{SS}) (These pins are forcibly set to the segment output port function and held at the V _{SS} level.) S5 to S35 = low (V _{SS}) COM1 to COM4 = low (V _{SS}) OSC = Z (high impedance) RC oscillation stopped Inhibits external clock input. • $\overline{\text{INH}}$ = high (V _{DD})...Display on RC oscillation enabled (RC oscillator operating mode) Enables external clock input (external clock operating mode). However, serial data transfer is possible when the display is forced off.	L	I	GND
V _{DD1}	41	Used to apply the LCD drive 2/3 bias voltage externally.	-	I	OPEN
V _{DD2}	42	Used to apply the LCD drive 1/3 bias voltage externally.	-	I	OPEN
V _{DD}	40	Power supply pin. A power voltage of 4.5 to 6.0 V must be applied to this pin.	-	-	-
V _{SS}	43	Ground pin. Must be connected to ground.	-	-	-

LC75836W

2. When CL is stopped at the high level

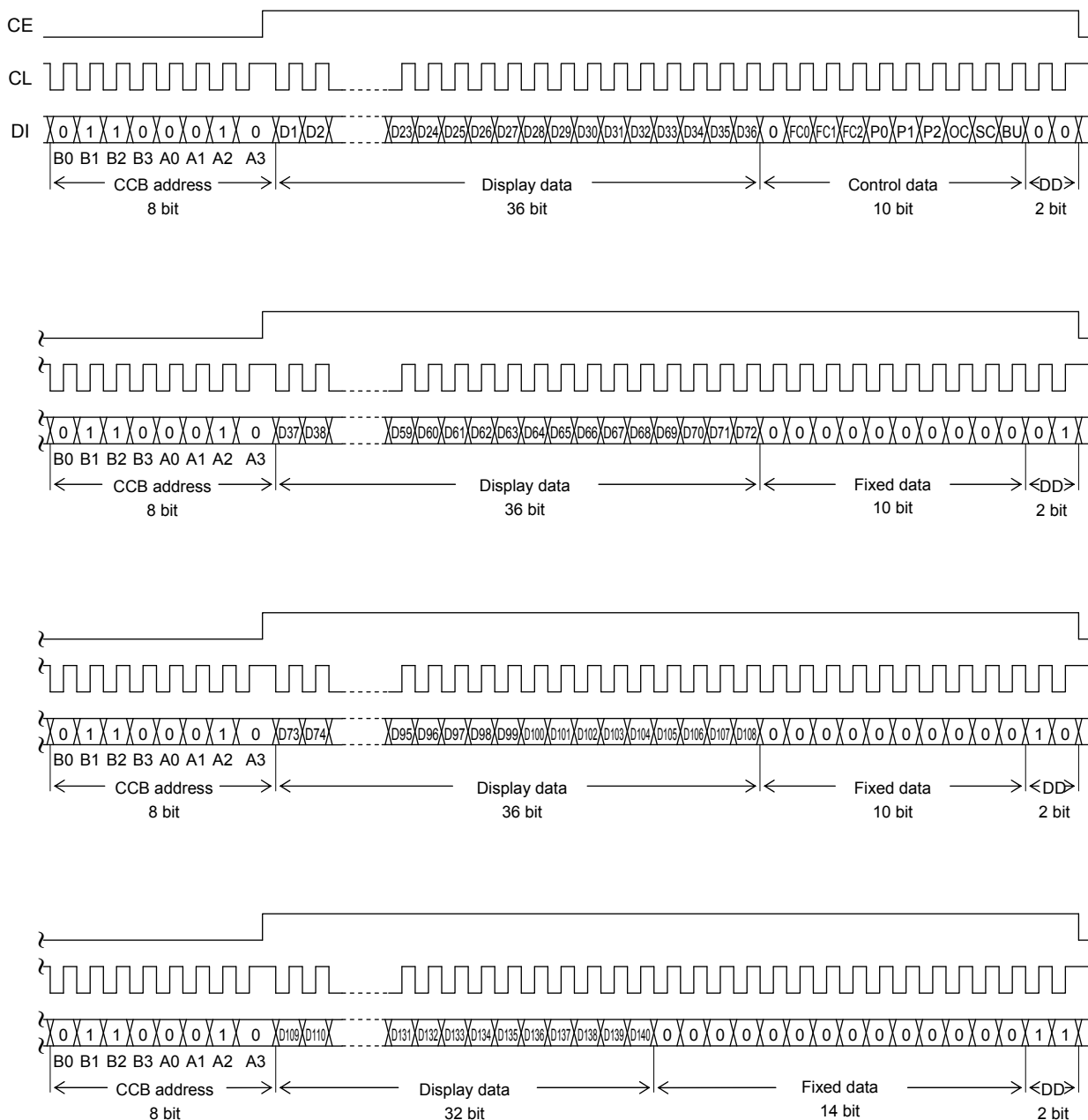

Note: DD is the direction data.

- CCB address "46H"
- D1 to D140 Display data
- FC0 to FC2 Common/segment output waveform frame frequency control data
- P0 to P2 Segment output port/general-purpose output port switching control data
- OC RC oscillator operating mode/external clock operating mode switching control data
- SC Segments on/off control data
- BU Normal mode/power-saving mode control data

Control Data Functions

1. FC0 to FC2: Common/segment output waveform frame frequency control data

These control data bits set the frame frequency of the common and segment output waveforms.

Control data			Frame frequency fo [Hz]
FC0	FC1	FC2	
1	1	0	$f_{osc}/768, f_{CK}/768$
1	1	1	$f_{osc}/576, f_{CK}/576$
0	0	0	$f_{osc}/384, f_{CK}/384$
0	0	1	$f_{osc}/288, f_{CK}/288$
0	1	0	$f_{osc}/192, f_{CK}/192$

2. P0 to P2: Segment output port/general-purpose output port switching control data

These control data bits switch the segment output port/general-purpose output port functions of the S1/P1 to S4/P4 output pins.

Control data			Output pin state			
P0	P1	P2	S1/P1	S2/P2	S3/P3	S4/P4
0	0	0	S1	S2	S3	S4
0	0	1	P1	S2	S3	S4
0	1	0	P1	P2	S3	S4
0	1	1	P1	P2	P3	S4
1	0	0	P1	P2	P3	P4

Note: Sn (n = 1 to 4): Segment output ports

Pn (n = 1 to 4): General-purpose output ports

Note that when the general-purpose output port function is selected, the correspondence between the output pins and the display data will be that shown in the table.

Output pin	Corresponding display data
S1/P1	D1
S2/P2	D5
S3/P3	D9
S4/P4	D13

For example, if the general-purpose output port function is selected for the S4/P4 output pin, that output pin will output a high level (VDD) when the display data D13 is 1, and a low level (VSS) when the D13 is 0.

3. OC: RC oscillator operating mode/external clock operating mode switching control data.

This control data bit switches the OSC pin function (either RC oscillator operating mode or external clock operating mode).

OC	OSC pin function
0	RC oscillator operating mode
1	External clock operating mode

Note: An external resistor, Rosc, and an external capacitor, Cosc, must be connected to the OSC pin if RC oscillator operating mode is selected.

4. SC: Segment on/off control data

This control data bit controls the on/off state of the segments.

SC	Display state
0	On
1	Off

Note that when the segments are turned off by setting SC to 1, the segments are turned off by outputting segment off waveforms from the segment output pins.

5. BU: Normal mode/power-saving mode control data

This control data bit selects either normal mode or power saving mode.

BU	Mode
0	Normal mode
1	Power saving mode. (In RC oscillator operating mode (OC = 0), the OSC pin oscillator is stopped, and in external clock operating mode (OC = 1), acceptance of the external clock is stopped. In this mode the common and segment output pins go to the VSS levels. However, S1/P1 to S4/P4 output pins that are set to be general-purpose output ports by the control data P0 to P2 can be used as general-purpose output ports.)

LC75836W

Display Data and Output Pin Correspondence

Output pin	COM1	COM2	COM3	COM4	Output pin	COM1	COM2	COM3	COM4
S1/P1	D1	D2	D3	D4	S19	D73	D74	D75	D76
S2/P2	D5	D6	D7	D8	S20	D77	D78	D79	D80
S3/P3	D9	D10	D11	D12	S21	D81	D82	D83	D84
S4/P4	D13	D14	D15	D16	S22	D85	D86	D87	D88
S5	D17	D18	D19	D20	S23	D89	D90	D91	D92
S6	D21	D22	D23	D24	S24	D93	D94	D95	D96
S7	D25	D26	D27	D28	S25	D97	D98	D99	D100
S8	D29	D30	D31	D32	S26	D101	D102	D103	D104
S9	D33	D34	D35	D36	S27	D105	D106	D107	D108
S10	D37	D38	D39	D40	S28	D109	D110	D111	D112
S11	D41	D42	D43	D44	S29	D113	D114	D115	D116
S12	D45	D46	D47	D48	S30	D117	D118	D119	D120
S13	D49	D50	D51	D52	S31	D121	D122	D123	D124
S14	D53	D54	D55	D56	S32	D125	D126	D127	D128
S15	D57	D58	D59	D60	S33	D129	D130	D131	D132
S16	D61	D62	D63	D64	S34	D133	D134	D135	D136
S17	D65	D66	D67	D68	S35	D137	D138	D139	D140
S18	D69	D70	D71	D72					

Note: Applies when the S1/P1 to S4/P4 output pins are set to their segment output function.

For example, the table below lists the output states for the S21 output pin.

Display data				Output pin (S21) state
D81	D82	D83	D84	
0	0	0	0	The LCD segments corresponding to COM1, COM2, COM3, and COM4 are off.
0	0	0	1	The LCD segment corresponding to COM4 is on.
0	0	1	0	The LCD segment corresponding to COM3 is on.
0	0	1	1	The LCD segments corresponding to COM3 and COM4 are on.
0	1	0	0	The LCD segment corresponding to COM2 is on.
0	1	0	1	The LCD segments corresponding to COM2 and COM4 are on.
0	1	1	0	The LCD segments corresponding to COM2 and COM3 are on.
0	1	1	1	The LCD segments corresponding to COM2, COM3, and COM4 are on.
1	0	0	0	The LCD segment corresponding to COM1 is on.
1	0	0	1	The LCD segments corresponding to COM1 and COM4 are on.
1	0	1	0	The LCD segments corresponding to COM1 and COM3 are on.
1	0	1	1	The LCD segments corresponding to COM1, COM3, and COM4 are on.
1	1	0	0	The LCD segments corresponding to COM1 and COM2 are on.
1	1	0	1	The LCD segments corresponding to COM1, COM2, and COM4 are on.
1	1	1	0	The LCD segments corresponding to COM1, COM2, and COM3 are on.
1	1	1	1	The LCD segments corresponding to COM1, COM2, COM3, and COM4 are on.

LC75836W

Output Waveforms (1/4-Duty 1/3-Bias Drive Scheme)

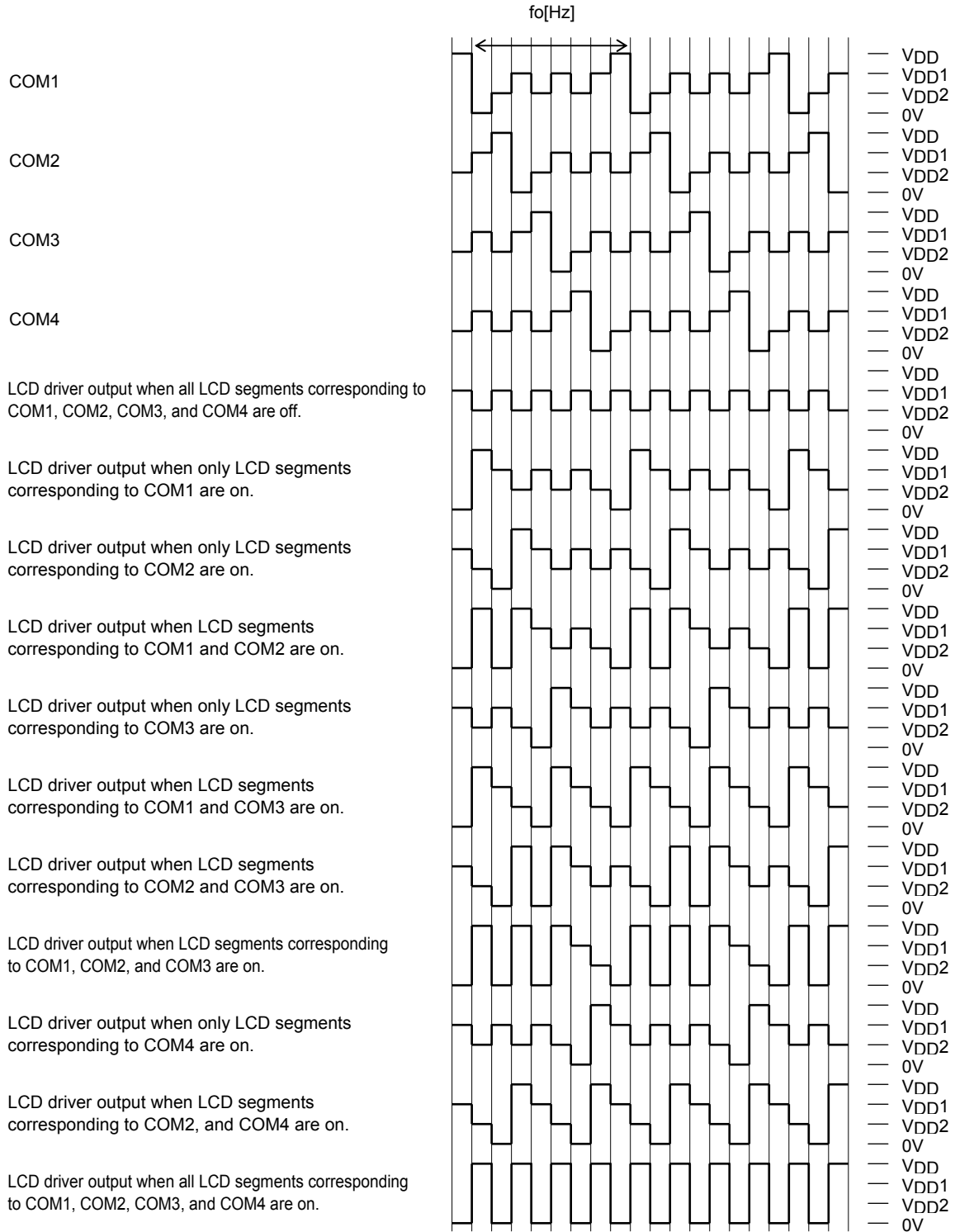

Control data			Frame frequency f_o [Hz]
FC0	FC1	FC2	
1	1	0	$f_{osc}/768, f_{CK}/768$
1	1	1	$f_{osc}/576, f_{CK}/576$
0	0	0	$f_{osc}/384, f_{CK}/384$
0	0	1	$f_{osc}/288, f_{CK}/288$
0	1	0	$f_{osc}/192, f_{CK}/192$

Display Control and the $\overline{\text{INH}}$ Pin

Since the LSI internal data (the display data D1 to D140 and the control data) is undefined when power is first applied, applications should set the $\overline{\text{INH}}$ pin low at the same time as power is applied to turn off the display. (This sets the S1/P1 to S4/P4, S5 to S35, and COM1 to COM4 pins to the V_{SS} level.) and during this period send serial data from the controller. The controller should then set the $\overline{\text{INH}}$ pin high after the data transfer has completed. This procedure prevents meaningless displays at power on. (See Figure 5.)

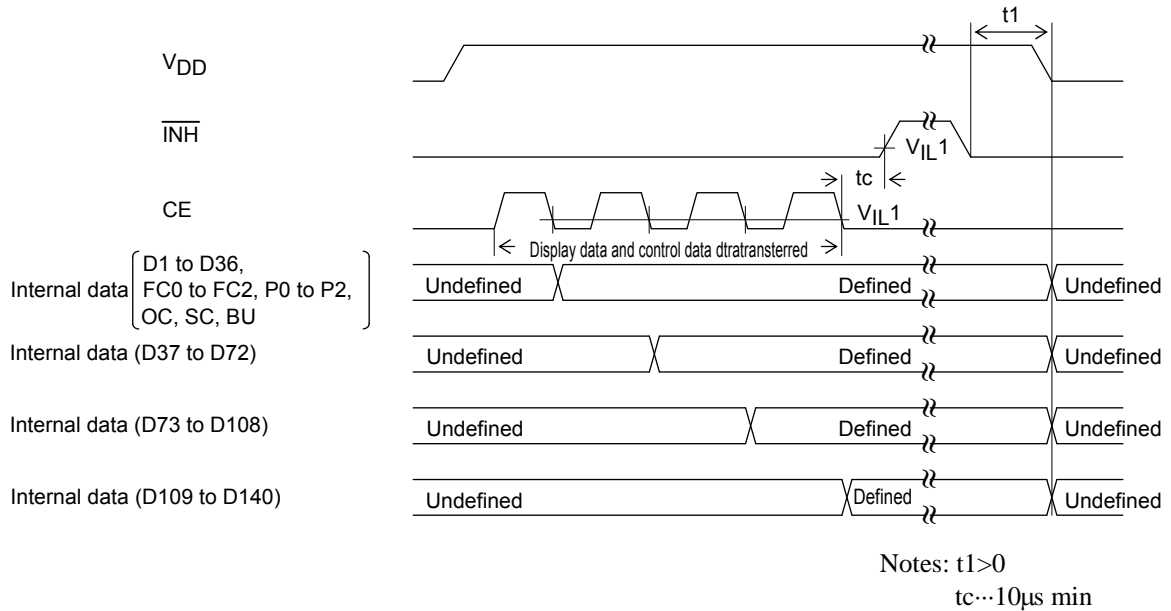

Figure 5

Notes on Controller Transfer of Display Data

Since the LC75836W transfer the display data (D1 to D140) in four separate transfer operations, we recommend that applications make a point of completing all four data transfers within a period of less than 30ms to prevent observable degradation of display quality.

OSC Pin Peripheral Circuit

(1) RC oscillator operating mode (control data OC = 0)

An external resistor, R_{osc} , and an external capacitor, C_{osc} , must be connected between the OSC pin and GND if RC oscillator operating mode is selected.

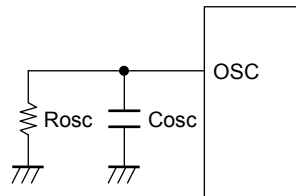

(2) External clock operating mode (control data OC = 1)

When the external clock operating mode is selected, insert a current protection resistor R_g (4.7 to 47 k Ω) between the OSC pin and external clock output pin (external oscillator). Determine the value of the resistance according to the allowable current value at the external clock output pin. Also make sure that the waveform of the external clock is not heavily distorted.

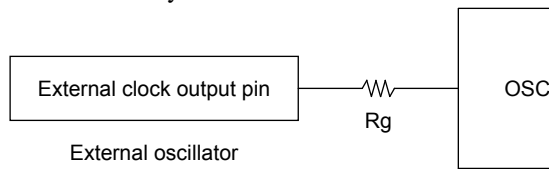

Note: Allowable current value at external clock output pin $> \frac{V_{DD}}{R_g}$

LC75836W

Sample Application Circuit 1

1/4 Duty, 1/3 Bias (for use with normal panels)

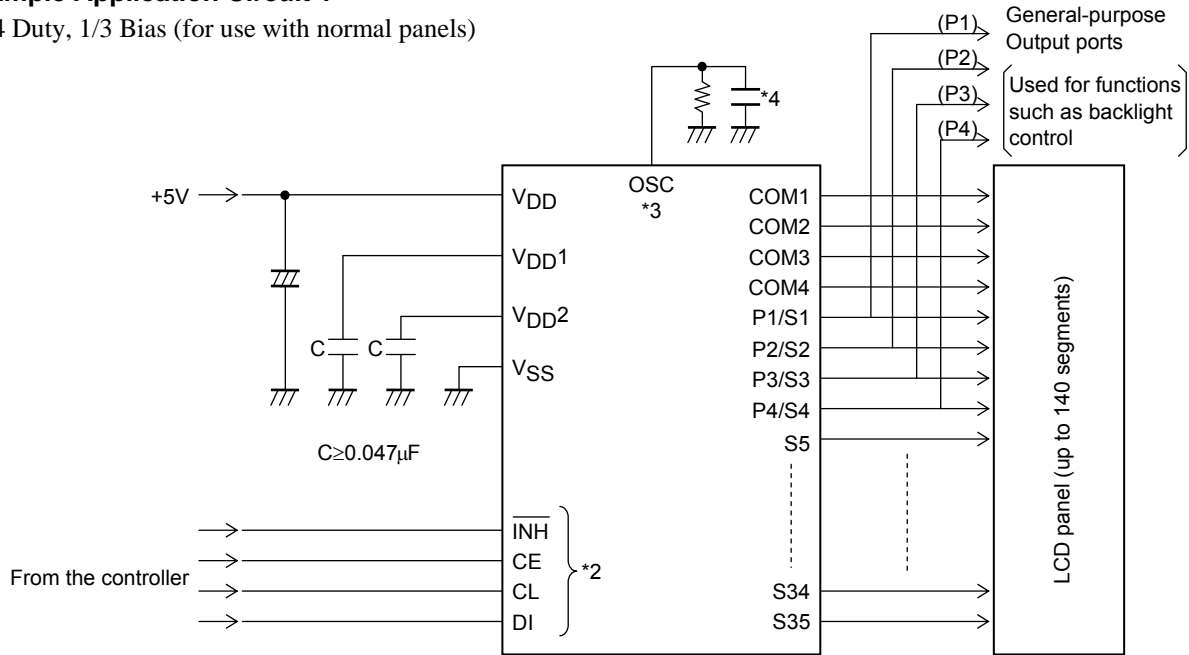

*2: The pins to be connected to the controller (CE, CL, DI, $\overline{\text{INH}}$) can handle 3 V.

*3: In RC oscillator operating mode, an external resistor, R_{osc} , and an external capacitor, C_{osc} , must be connected between the OSC pin and ground. If external clock operating mode is selected, a current protection resistor, R_g (4.7 to 47 k Ω), must be inserted between the external clock output pin (on the external oscillator) and the OSC pin. (See the "OSC Pin Peripheral Circuit" section.)

*4: When a capacitor except the recommended external capacitance ($C_{\text{osc}} = 1000 \text{ pF}$) is connected to the OSC pin, it should be in the range 220 to 2200 pF.

Sample Application Circuit 2

1/4 Duty, 1/3 Bias (for use with large panels)

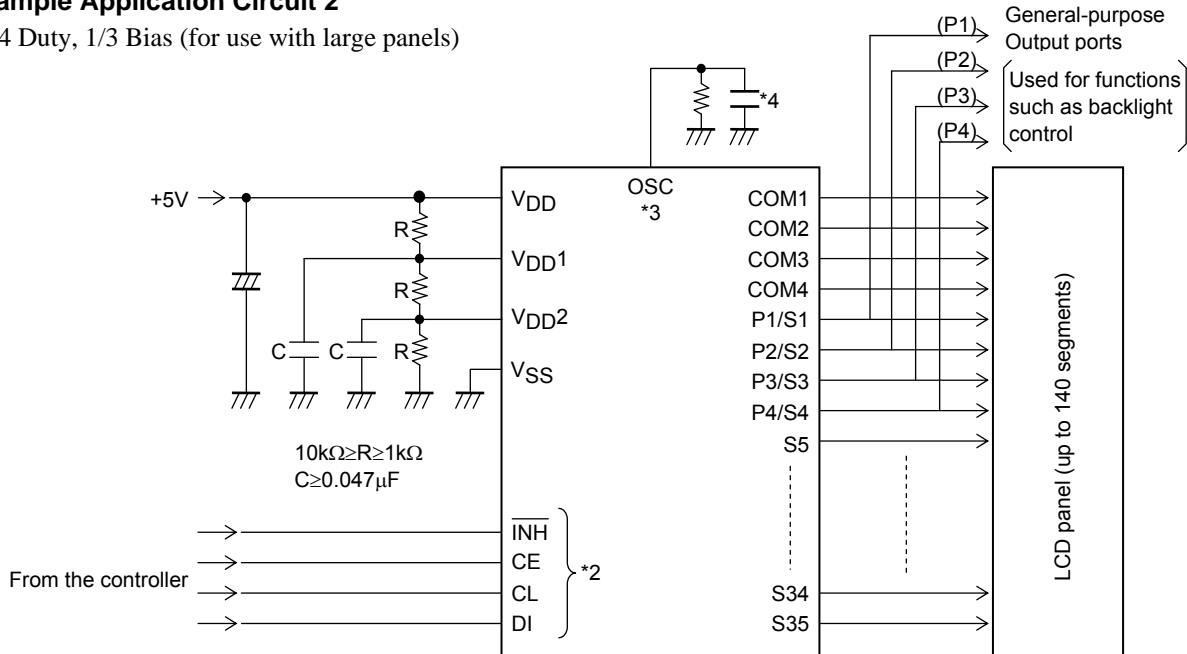

*2: The pins to be connected to the controller (CE, CL, DI, $\overline{\text{INH}}$) can handle 3 V.

*3: In RC oscillator operating mode, an external resistor, R_{osc} , and an external capacitor, C_{osc} , must be connected between the OSC pin and ground. If external clock operating mode is selected, a current protection resistor, R_g (4.7 to 47 k Ω), must be inserted between the external clock output pin (on the external oscillator) and the OSC pin. (See the "OSC Pin Peripheral Circuit" section.)

*4: When a capacitor except the recommended external capacitance ($C_{\text{osc}} = 1000 \text{ pF}$) is connected to the OSC pin, it should be in the range 220 to 2200 pF.

LC75836W

ORDERING INFORMATION



Device	Package	Shipping (Qty / Packing)
LC75836W-E	SQFP48 7x7 / SQFP48 (Pb-Free)	1250 / Tray JEDEC
LC75836W-TBM-E	SQFP48 7x7 / SQFP48 (Pb-Free)	1000 / Tape & Reel
LC75836WH-E	SQFP48 7x7 / SQFP48 (Pb-Free)	1250 / Tray JEDEC
LC75836WS-E	SQFP48 7x7 / SQFP48 (Pb-Free)	1250 / Tray JEDEC

† For information on tape and reel specifications, including part orientation and tape sizes, please refer to our Tape and Reel Packaging Specifications Brochure, BRD8011/D. http://www.onsemi.com/pub_link/Collateral/BRD8011-D.PDF

ON Semiconductor and the ON Semiconductor logo are trademarks of Semiconductor Components Industries, LLC dba ON Semiconductor or its subsidiaries in the United States and/or other countries. ON Semiconductor owns the rights to a number of patents, trademarks, copyrights, trade secrets, and other intellectual property. A listing of ON Semiconductor's product/patent coverage may be accessed at www.onsemi.com/site/pdf/Patent-Marking.pdf. ON Semiconductor reserves the right to make changes without further notice to any products herein. ON Semiconductor makes no warranty, representation or guarantee regarding the suitability of its products for any particular purpose, nor does ON Semiconductor assume any liability arising out of the application or use of any product or circuit, and specifically disclaims any and all liability, including without limitation special, consequential or incidental damages. Buyer is responsible for its products and applications using ON Semiconductor products, including compliance with all laws, regulations and safety requirements or standards, regardless of any support or applications information provided by ON Semiconductor. "Typical" parameters which may be provided in ON Semiconductor data sheets and/or specifications can and do vary in different applications and actual performance may vary over time. All operating parameters, including "Typicals" must be validated for each customer application by customer's technical experts. ON Semiconductor does not convey any license under its patent rights nor the rights of others. ON Semiconductor products are not designed, intended, or authorized for use as a critical component in life support systems or any FDA Class 3 medical devices or medical devices with a same or similar classification in a foreign jurisdiction or any devices intended for implantation in the human body. Should Buyer purchase or use ON Semiconductor products for any such unintended or unauthorized application, Buyer shall indemnify and hold ON Semiconductor and its officers, employees, subsidiaries, affiliates, and distributors harmless against all claims, costs, damages, and expenses, and reasonable attorney fees arising out of, directly or indirectly, any claim of personal injury or death associated with such unintended or unauthorized use, even if such claim alleges that ON Semiconductor was negligent regarding the design or manufacture of the part. ON Semiconductor is an Equal Opportunity/Affirmative Action Employer. This literature is subject to all applicable copyright laws and is not for resale in any manner.

Looking for pricing, stock, or lifecycle information?

Click below to explore more details on WIN SOURCE:

-  [View LC75836WS-E on WIN SOURCE](#)
-  [ON Semiconductor](#) Information

Optimize Your Supply Chain with WIN SOURCE Solutions

-  Global Sourcing Solution
-  Obsolete Management
-  Cost Control Management
-  Shortage Management
-  Alternative Solution
-  Excess Inventory Management