



**THE DATASHEET OF
LC75829PEH-TLA-H**



LC75829PE, LC75829PW

1/4, 1/3-Duty General-Purpose LCD Driver



ON Semiconductor®

www.onsemi.com

Overview

The LC75829PE and LC75829PW are 1/4 duty and 1/3 duty general-purpose microprocessor-controlled LCD drivers that can be used in applications such as frequency display in products with electronic tuning. In addition to being able to drive up to 208 segments directly, the LC75829PE and LC75829PW can also control up to 4 general-purpose output ports. Incorporation of an oscillation circuit helps to reduce the number of external resistors and capacitors required.

Features

- Support for 1/4-duty 1/3-bias or 1/3-duty 1/3-bias drive techniques under serial data control.
 - When 1/4-duty: Capable of driving up to 208 segments
 - When 1/3-duty: Capable of driving up to 159 segments
- Serial data input supports CCB* format communication with the system controller. (Support 3.3 V and 5 V operation)
- Serial data control of the power-saving mode based backup function and the all segments forced off function.
- Serial data control of switching between the segment output port and general-purpose output port function.
(Support for up to 4 general-purpose output ports)
- Support for clock output function of 1ch.
- Serial data control of the frame frequency of the common and segment output waveforms.
- Serial data control of switching between the internal oscillator operating mode and external clock operating mode.
- High generality, since display data is displayed directly without the intervention of a decoder circuit.
- The INH pin allows the display to be forced to the off state.
- Incorporation of an oscillator circuit.
(Incorporation of resistor and capacitor for an oscillation)

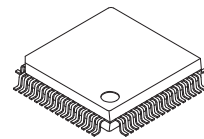

PQFP64 14x14 / QIP64E
[LC75829PE]

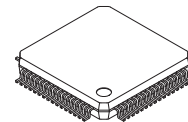

SPQFP64 10x10 / SQFP64
[LC75829PW]

* Computer Control Bus (CCB) is an ON Semiconductor's original bus format and the bus addresses are controlled by ON Semiconductor.

ORDERING INFORMATION

See detailed ordering and shipping information on page 23 of this data sheet.

LC75829PE, LC75829PW

Specifications

Absolute Maximum Ratings at Ta = 25°C, VSS = 0 V

Parameter	Symbol	Conditions	Ratings	Unit
Maximum supply voltage	VDD max	VDD	-0.3 to +6.5	V
Input voltage	VIN1	CE, CL, DI, $\overline{\text{INH}}$	-0.3 to +6.5	V
	VIN2	OSCI, VDD1, VDD2	-0.3 to VDD+0.3	
Output voltage	VOUT	S1 to S53, COM1 to COM4, P1 to P4	-0.3 to VDD+0.3	V
Output current	IOUT1	S1 to S52	300	μA
	IOUT2	COM1 to COM4, S53	3	
	IOUT3	P1 to P4	5	
Allowable power dissipation	Pd max	Ta = 85°C	200	mW
Operating temperature	Topr		-40 to +85	°C
Storage temperature	Tstg		-55 to +125	°C

Stresses exceeding those listed in the Maximum Ratings table may damage the device. If any of these limits are exceeded, device functionality should not be assumed, damage may occur and reliability may be affected.

Allowable Operating Ranges at Ta = -40 to +85°C, VSS = 0 V

Parameter	Symbol	Conditions	Ratings			Unit
			min	typ	max	
Supply voltage	VDD	VDD	4.5		6.0	V
Input voltage	VDD1	VDD1		2/3VDD	VDD	V
	VDD2	VDD2		1/3VDD	VDD	
Input high-level voltage	VIH1	CE, CL, DI, $\overline{\text{INH}}$	0.4VDD		6.0	V
	VIH2	OSCI: External clock operating mode	0.4VDD		VDD	
Input low-level voltage	VIL1	CE, CL, DI, $\overline{\text{INH}}$	0		0.2VDD	V
	VIL2	OSCI: External clock operating mode	0		0.2VDD	
External clock operating frequency	fCK	OSCI: External clock operating mode [Figure 4]	10	300	600	kHz
External clock duty cycle	DCK	OSCI: External clock operating mode [Figure 4]	30	50	70	%
Data setup time	tds	CL, DI [Figure 2] [Figure 3]	160			ns
Data hold time	tdh	CL, DI [Figure 2] [Figure 3]	160			ns
CE wait time	tcp	CE, CL [Figure 2] [Figure 3]	160			ns
CE setup time	tcs	CE, CL [Figure 2] [Figure 3]	160			ns
CE hold time	tch	CE, CL [Figure 2] [Figure 3]	160			ns
High-level clock pulse width	tφH	CL [Figure 2] [Figure 3]	160			ns
Low-level clock pulse width	tφL	CL [Figure 2] [Figure 3]	160			ns
Rise time	tr	CE, CL, DI [Figure 2] [Figure 3]		160		ns
Fall time	tf	CE, CL, DI [Figure 2] [Figure 3]		160		ns
$\overline{\text{INH}}$ switching time	tc	$\overline{\text{INH}}$, CE [Figure 5] [Figure 6]	10			μs

Functional operation above the stresses listed in the Recommended Operating Ranges is not implied. Extended exposure to stresses beyond the Recommended Operating Ranges limits may affect device reliability.

LC75829PE, LC75829PW

Electrical Characteristics for the Allowable Operating Ranges

Parameter	Symbol	Pin	Conditions	Ratings			Unit
				min	typ	max	
Hysteresis	V_H	CE, CL, DI, \overline{INH}			$0.03V_{DD}$		V
Input high-level current	I_{IH1}	CE, CL, DI, \overline{INH}	$V_I = 6.0\text{ V}$			5.0	μA
	I_{IH2}	OSCI	$V_I = V_{DD}$: External clock operating mode			5.0	
Input low-level current	I_{IL1}	CE, CL, DI, \overline{INH}	$V_I = 0\text{ V}$	-5.0			μA
	I_{IL2}	OSCI	$V_I = 0\text{ V}$: External clock operating mode	-5.0			
Output high-level voltage	V_{OH1}	S1 to S53	$I_O = -20\ \mu\text{A}$	V_{DD} -0.9			V
	V_{OH2}	COM1 to COM4	$I_O = -100\ \mu\text{A}$	V_{DD} -0.9			
	V_{OH3}	P1 to P4	$I_O = -1\ \text{mA}$	V_{DD} -0.9			
Output low-level voltage	V_{OL1}	S1 to S53	$I_O = 20\ \mu\text{A}$			0.9	V
	V_{OL2}	COM1 to COM4	$I_O = 100\ \mu\text{A}$			0.9	
	V_{OL3}	P1 to P4	$I_O = 1\ \text{mA}$			0.9	
Output middle-level voltage *1	V_{MID1}	S1 to S53	1/3 bias $I_O = \pm 20\ \mu\text{A}$	$2/3V_{DD}$ -0.9		$2/3V_{DD}$ +0.9	V
	V_{MID2}	S1 to S53	1/3 bias $I_O = \pm 20\ \mu\text{A}$	$1/3V_{DD}$ -0.9		$1/3V_{DD}$ +0.9	
	V_{MID3}	COM1 to COM4	1/3 bias $I_O = \pm 100\ \mu\text{A}$	$2/3V_{DD}$ -0.9		$2/3V_{DD}$ +0.9	
	V_{MID4}	COM1 to COM4	1/3 bias $I_O = \pm 100\ \mu\text{A}$	$1/3V_{DD}$ -0.9		$1/3V_{DD}$ +0.9	
Oscillator frequency	fosc	Internal oscillator circuit	Internal oscillator operating mode	240	300	360	kHz
Current drain	I_{DD1}	V_{DD}	Power-saving mode			100	μA
	I_{DD2}	V_{DD}	$V_{DD} = 6.0\text{ V}$ Output open Internal oscillator operating mode		800	1600	
	I_{DD3}	V_{DD}	$V_{DD} = 6.0\text{ V}$ Output open External clock operating mode $f_{CK} = 300\text{ kHz}$ $V_{IH2} = 0.5V_{DD}$ $V_{IL2} = 0.1V_{DD}$		800	1600	

Note: *1 Excluding the bias voltage generation divider resistors built in the V_{DD1} and V_{DD2} . (See Figure 1.)

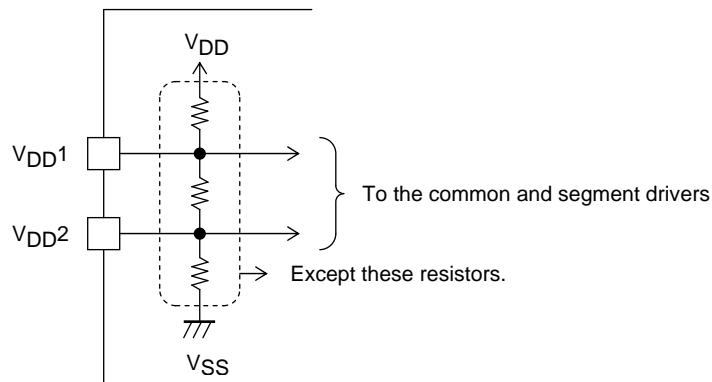

[Figure 1]

Product parametric performance is indicated in the Electrical Characteristics for the listed test conditions, unless otherwise noted. Product performance may not be indicated by the Electrical Characteristics if operated under different conditions.

LC75829PE, LC75829PW

1. When CL is stopped at the low level

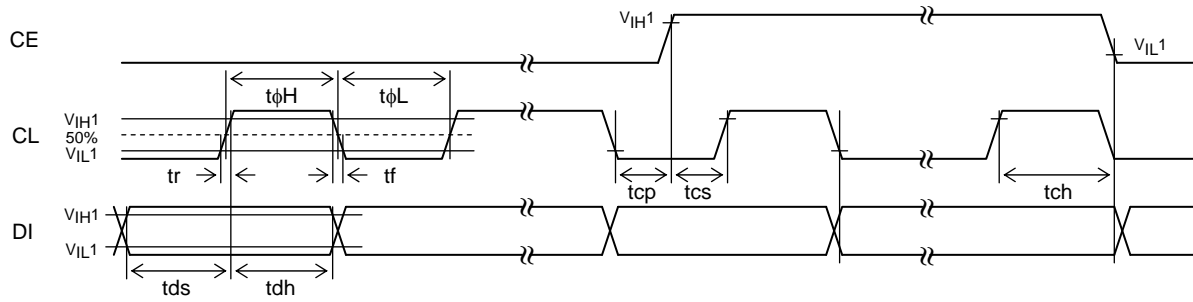

[Figure 2]

2. When CL is stopped at the high level

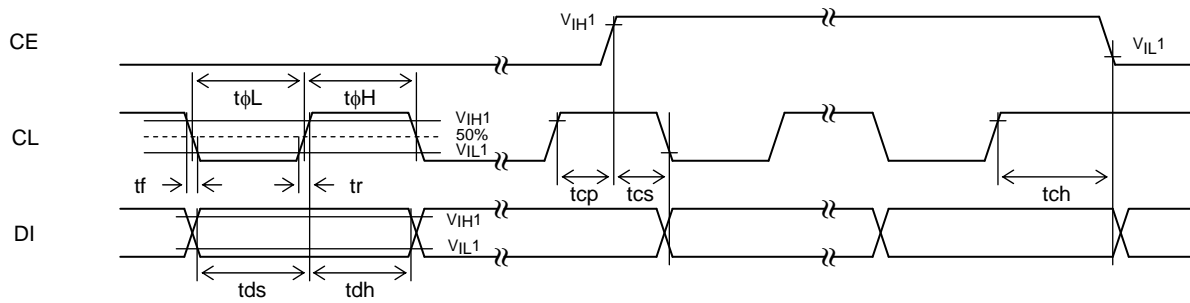

[Figure 3]

3. OSCI pin clock timing in external clock operating mode

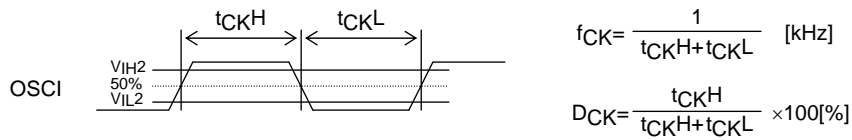

[Figure 4]

LC75829PE, LC75829PW

Package Dimensions

unit : mm

[LC75829PE]

PQFP64 14x14 / QIP64E

CASE 122BP

ISSUE A

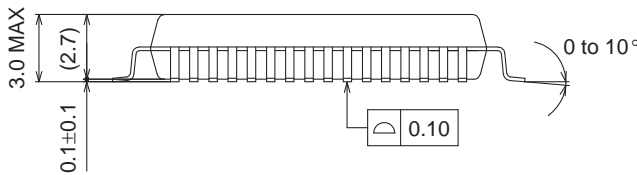
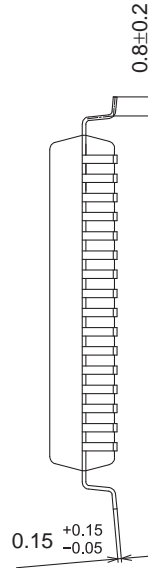
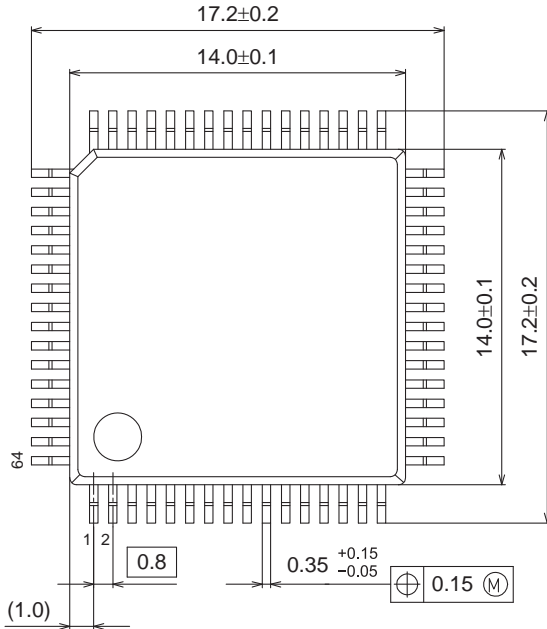

SOLDERING FOOTPRINT*

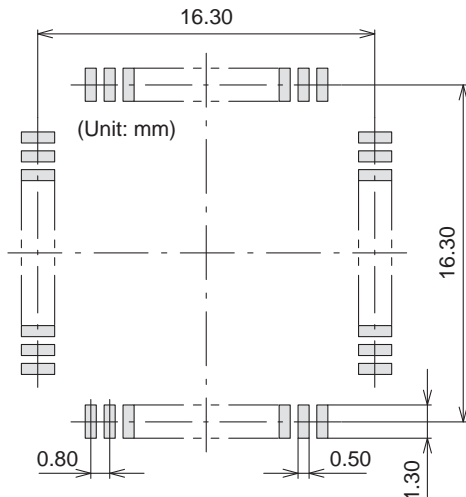

GENERIC MARKING DIAGRAM*

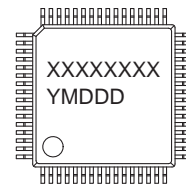

XXXXX = Specific Device Code
 Y = Year
 M = Month
 DDD = Additional Traceability Data

*This information is generic. Please refer to device data sheet for actual part marking. Pb-Free indicator, "G" or microdot "•", may or may not be present.

NOTE: The measurements are not to guarantee but for reference only.

*For additional information on our Pb-Free strategy and soldering details, please download the ON Semiconductor Soldering and Mounting Techniques Reference Manual, SOLDERRM/D.

LC75829PE, LC75829PW

Package Dimensions

unit : mm

[LC75829PW]

SPQFP64 10x10 / SQFP64

CASE 131AK

ISSUE A

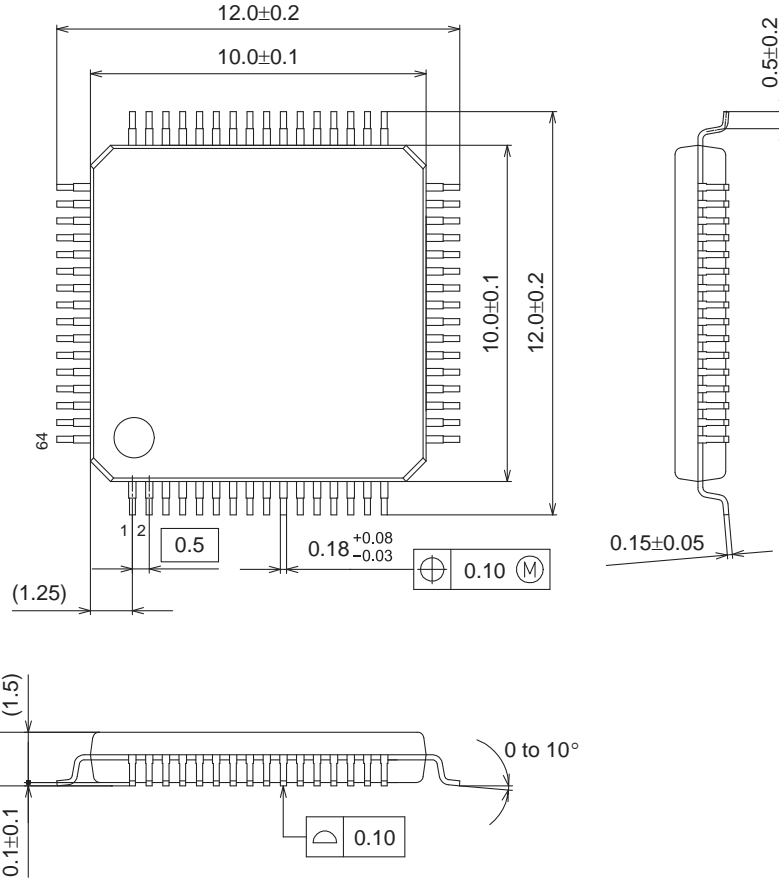

SOLDERING FOOTPRINT*

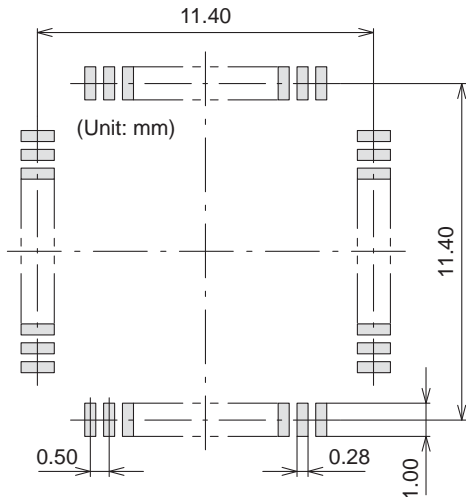

GENERIC MARKING DIAGRAM*

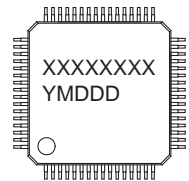
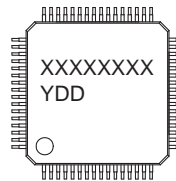

XXXXXX = Specific Device Code
Y = Year
DD = Additional Traceability Data

XXXXXX = Specific Device Code
Y = Year
M = Month
DDD = Additional Traceability Data

*This information is generic. Please refer to device data sheet for actual part marking. Pb-Free indicator, "G" or microdot "▪", may or may not be present.

NOTE: The measurements are not to guarantee but for reference only.

*For additional information on our Pb-Free strategy and soldering details, please download the ON Semiconductor Soldering and Mounting Techniques Reference Manual, SOLDERRM/D.

LC75829PE, LC75829PW

Pin Assignment

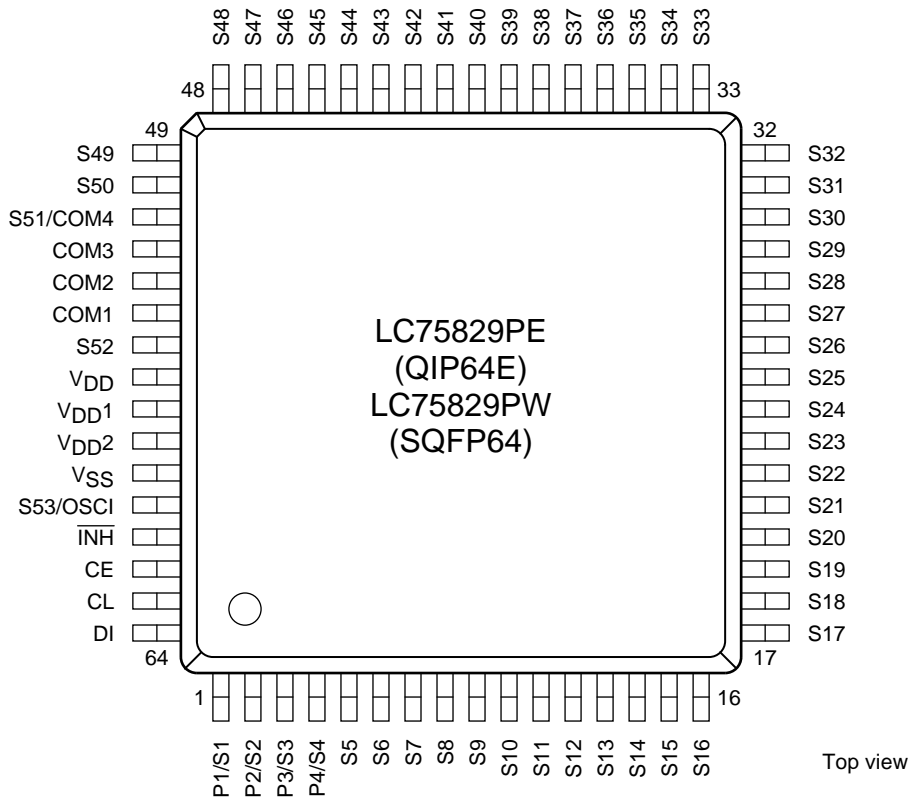

Block Diagram

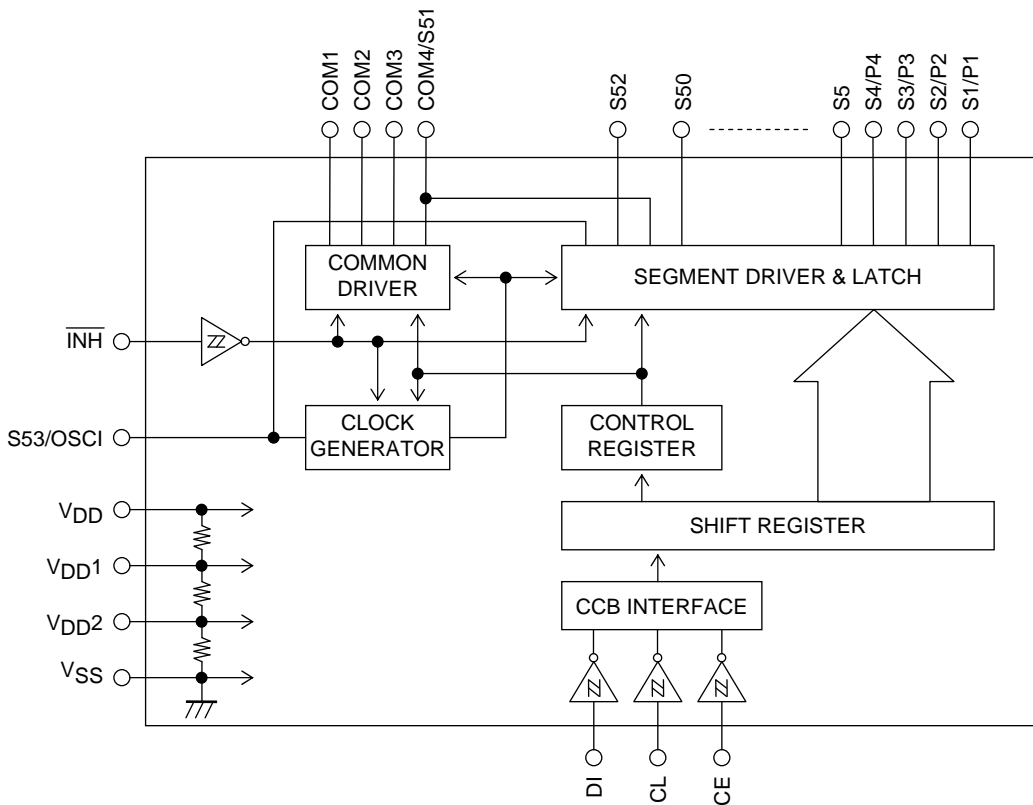

LC75829PE, LC75829PW

Pin Functions

Symbol	Pin No.	Function	Active	I/O	Handling when unused
S1/P1 to S4/P4 S5 to S50 S52	1 to 4 5 to 50 55	Segment outputs for displaying the display data transferred by serial data input. The S1/P1 to S4/P4 pins can be used as general-purpose output ports under serial data control.	-	O	OPEN
COM1 to COM3 COM4/S51	54 to 52 51	Common driver outputs The frame frequency is f_0 [Hz]. The COM4/S51 pin can be used as a segment output in 1/3 duty.	-	O	OPEN
S53/OSCI	60	Segment output. This pin can also be used as the external clock input pin when the external clock operating mode is selected by control data.	-	I/O	OPEN
CE CL DI	62 63 64	Serial data transfer inputs. Must be connected to the controller. CE: Chip enable CL: Synchronization clock DI: Transfer data	H  -	I I I	GND GND GND
$\overline{\text{INH}}$	61	Display off control input <ul style="list-style-type: none"> • $\overline{\text{INH}} = \text{low } (V_{SS})$...Display forced off <ul style="list-style-type: none"> S1/P1 to S4/P4 = low (V_{SS}) (These pins are forcibly set to the general-purpose output port function and held at the V_{SS} level.) S9 to S50, S52=low (V_{SS}) COM1 to COM3=low (V_{SS}) COM4/S51=low (V_{SS}) S53/OSCI=low (V_{SS}) (This pin is forcibly set to the segment output port function and held at the V_{SS} level.) Stops the internal oscillator. Inhibits external clock input. <ul style="list-style-type: none"> • $\overline{\text{INH}} = \text{high } (V_{DD})$...Display on <ul style="list-style-type: none"> Enables the internal oscillator circuit. (Internal oscillator operating mode) Enables external clock input. (External clock operating mode) <p>However, serial data transfer is possible when the display is forced off.</p>	L	I	GND
V_{DD1}	57	Used to apply the LCD drive 2/3 bias voltage externally.	-	I	OPEN
V_{DD2}	58	Used to apply the LCD drive 1/3 bias voltage externally.	-	I	OPEN
V_{DD}	56	Power supply pin. A power voltage of 4.5 to 6.0V must be applied to this pin.	-	-	-
V_{SS}	59	Ground pin. Must be connected to ground.	-	-	-

Serial Data Input

1. 1/4 duty

(1) When CL is stopped at the low level

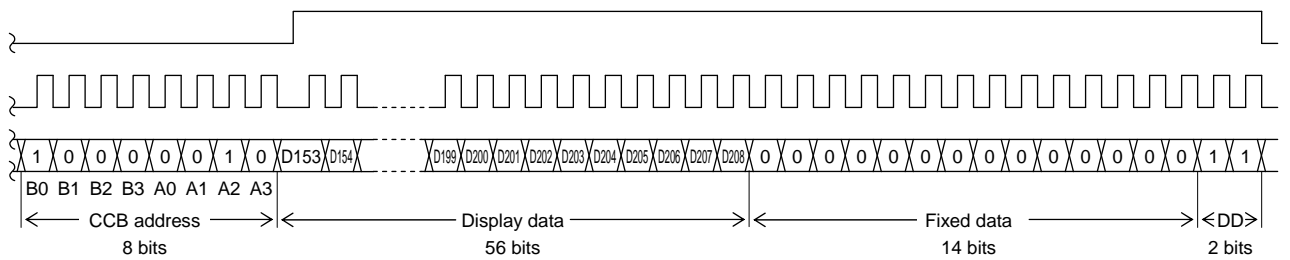
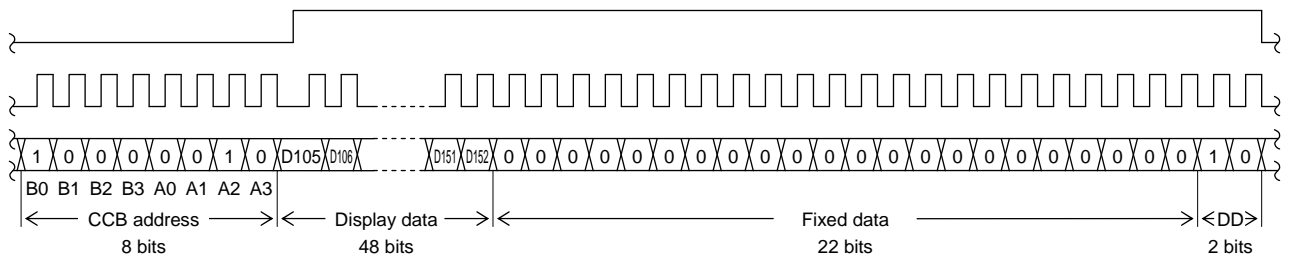
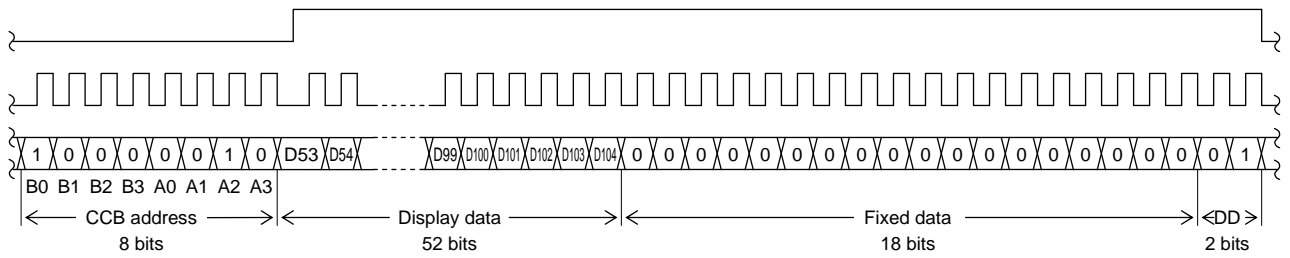
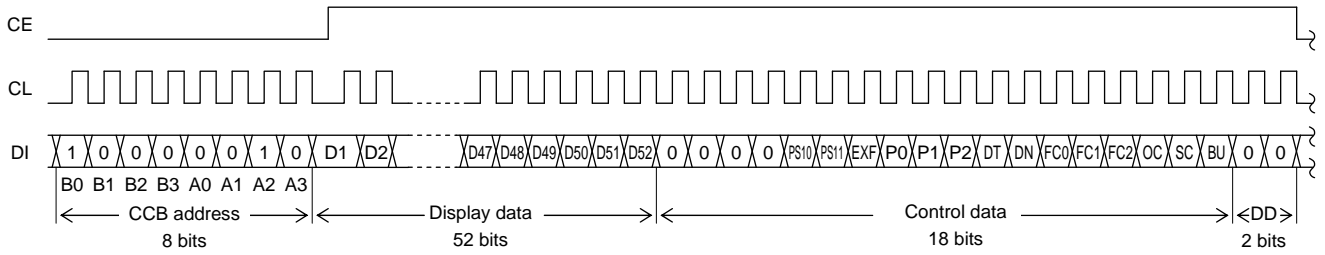

Note: DD is the direction data.

LC75829PE, LC75829PW

2. 1/3 duty

(1) When CL is stopped at the low level

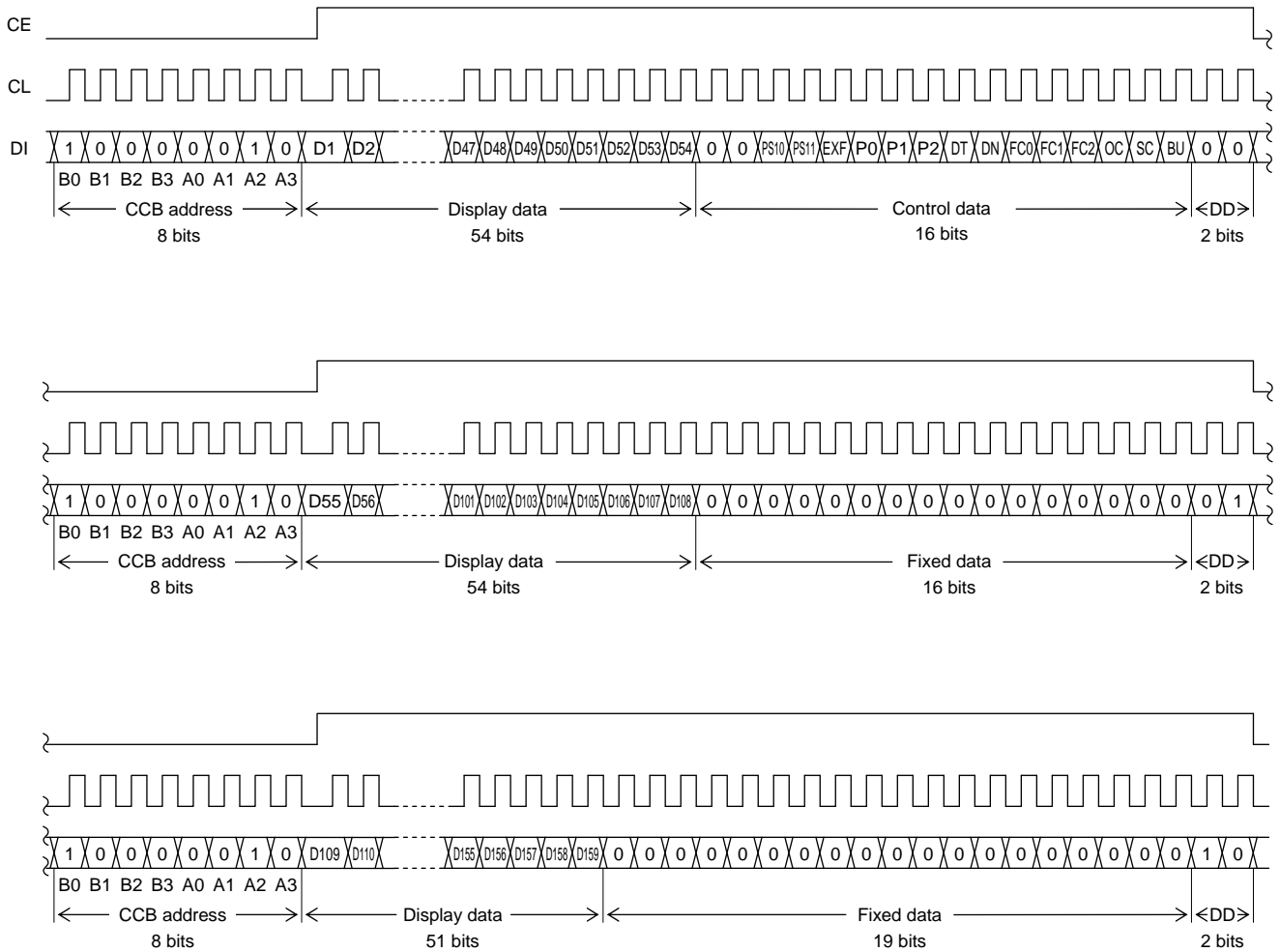

Note: DD is the direction data.

LC75829PE, LC75829PW

(2) When CL is stopped at the high level

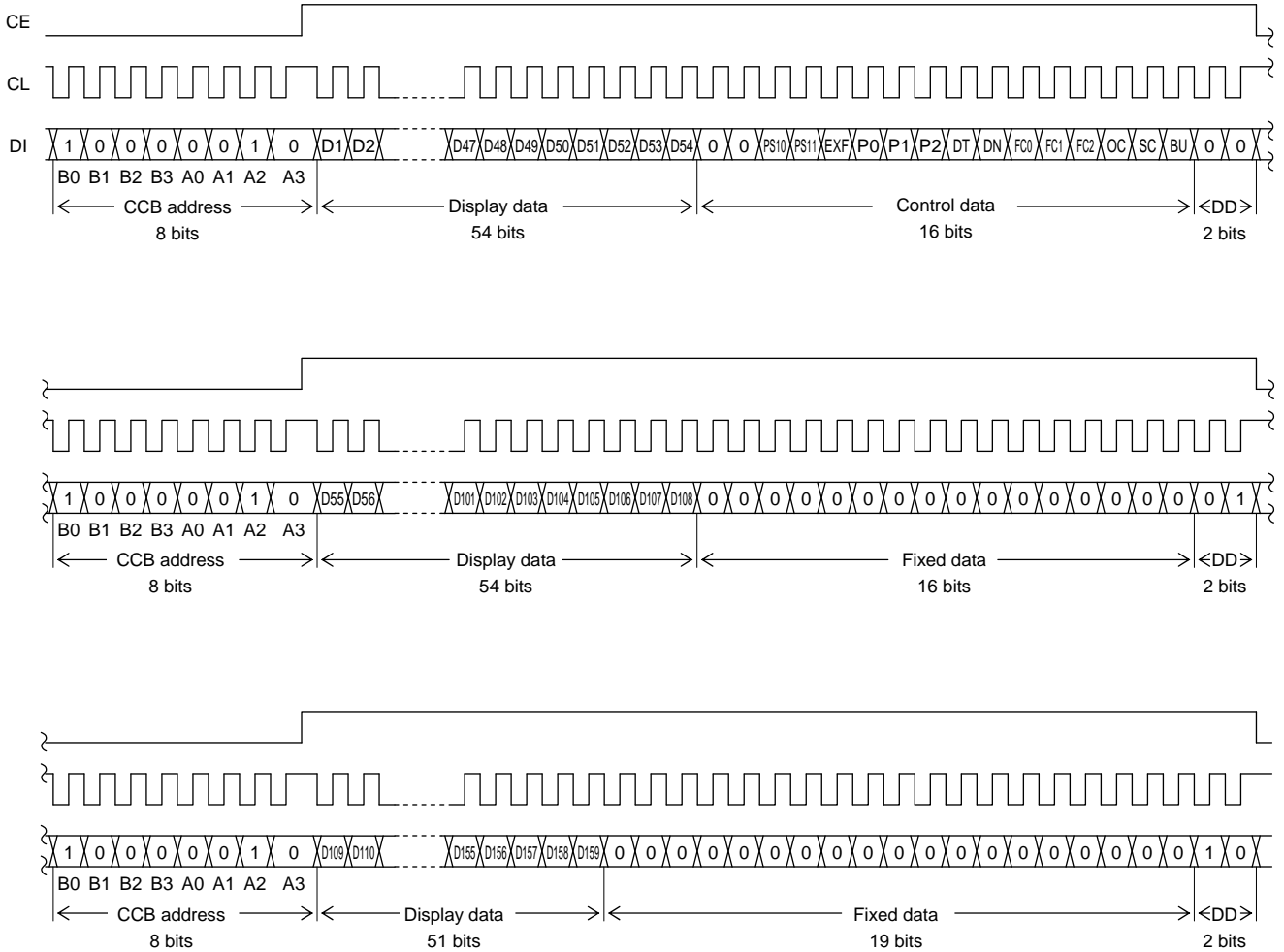

Note: DD is the direction data.

- CCB address “41H”
- D1 to D159 Display data
- PS10, PS11 General-purpose output port (P1) function setting control data
- EXF External clock operating frequency setting control data
- P0 to P2 Segment output port/general-purpose output port switching control data
- DT 1/4-duty 1/3-bias drive or 1/3-duty 1/3-bias drive switching control data
- DN S52 pin and S53/OSCI pin state setting control data
- FC0 to FC2 Common/segment output waveform frame frequency control data
- OC Internal oscillator operating mode/external clock operating mode switching control data
- SC Segment on/off control data
- BU Normal mode/power-saving mode control data

Serial Data Transfer Example

1. 1/4 duty

- When 153 or more segments are used
All 288 bits of serial data must be sent.



- When fewer than 153 segments are used
Either 72, 144, or 216 bits of serial data must be sent, depending on the number of segments to be used.
However, the serial data shown below (the D1 to D52 display data and the control data) must always be sent.

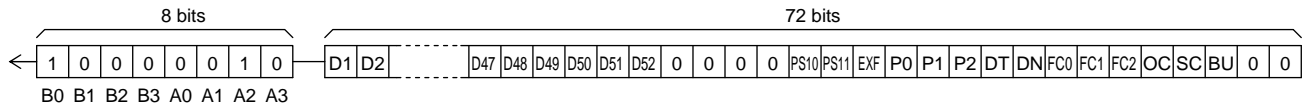

2. 1/3 duty

- When 109 or more segments are used
All 216 bits of serial data must be sent.

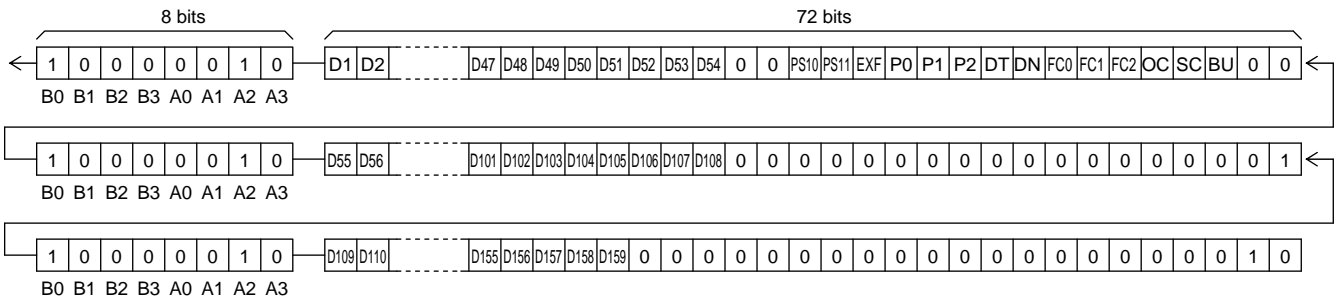

- When fewer than 109 segments are used
Either 72, or 144 bits of serial data must be sent, depending on the number of segments to be used.
However, the serial data shown below (the D1 to D54 display data and the control data) must always be sent.

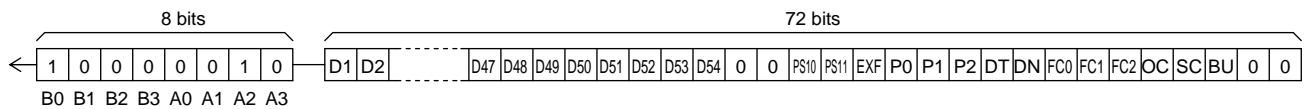

Control Data Functions

(1) PS10 and PS11 ... General-purpose output port (P1) function setting control data

These control data bits set the clock output or general-purpose output function (High or low level output) of the P1 output pin.

PS10	PS11	General-purpose output port (P1) function
0	0	General-purpose output function (High or low level output)
1	0	Clock output function (Clock frequency : fosc/2, f _{CK} /2)
0	1	Clock output function (Clock frequency : fosc/8, f _{CK} /8)

Note: When is setting (PS10, PS11)=(1,1), the P1 output pin selects the general-purpose output function (High or low level output).

(2) EXF ... External clock operating frequency setting control data

This control data sets the operating frequency of the external clock which input into the OSCI pin, when the external clock operating mode (OC="1") is set. However, this data is effective only when external clock operating mode (OC="1") is set.

EXF	External clock operating frequency f _{CK} [kHz]
0	f _{CK1} =300[kHz]typ
1	f _{CK2} =38[kHz]typ

(3) P0 to P2 ... Segment output port/general-purpose output port switching control data

These control data bits switch the segment output port/general-purpose output port functions of the S1/P1 to S4/P4 output pins.

Control data			Output pin state			
P0	P1	P2	S1/P1	S2/P2	S3/P3	S4/P4
0	0	0	S1	S2	S3	S4
0	0	1	P1	S2	S3	S4
0	1	0	P1	P2	S3	S4
0	1	1	P1	P2	P3	S4
1	0	0	P1	P2	P3	P4

Note: Sn (n=1 to 4): Segment output ports
Pn (n=1 to 4): General-purpose output ports

Note: When are setting (P0,P1,P2)=(1,0,1), (1,1,0), and (1,1,1), the all P1/S1 to P4/S4 output pins selects the segment output port.

The table below lists the correspondence between the display data and the output pins when these pins are selected to be general-purpose output ports.

Output pin	Correspondence display data	
	1/4 duty	1/3 duty
S1/P1	D1	D1
S2/P2	D5	D4
S3/P3	D9	D7
S4/P4	D13	D10

For example, if the circuit is operated in 1/4 duty and the S4/P4 output pin is selected to be a general-purpose output port, the S4/P4 output pin will output a high level (V_{DD}) when the display data D13 is 1, and will output a low level (V_{SS}) when D13 is 0.

(4) DT ... 1/4-duty 1/3-bias drive or 1/3-duty 1/3-bias drive switching control data

This control data bit selects either 1/4-duty 1/3-bias drive or 1/3-duty 1/3-bias drive.

DT	Drive scheme	The COM4/S51 pin state
0	1/4-duty 1/3-bias drive	COM4
1	1/3-duty 1/3-bias drive	S51

Note: COM4: Common output
S51 : Segment output

LC75829PE, LC75829PW

(5) DN ... S52 pin and S53/OSCI pin state setting control data

This control data bit sets state of the S52 pin and the S53/OSCI pin.

DN	Number of display segments		Pin state	
	1/4 duty	1/3 duty	S52	S53/OSCI
0	Up to 200 segments	Up to 153 segments	"L" (V _{SS})	"L" (V _{SS})/OSCI
1	Up to 208 segments	Up to 159 segments	S52	S53/OSCI

Note: "L" (V_{SS}) : Low (V_{SS}) level output
 S52 : Segment output
 "L" (V_{SS})/OSCI : Low (V_{SS}) level output in internal oscillator operating mode (OC=0)
 : External clock input in external clock operating mode (OC=1)
 S53/OSCI : Segment output in internal oscillator operating mode (OC=0)
 : External clock input in external clock operating mode (OC=1)

(6) FC0 to FC2 ... Common/segment output waveform from frequency control data

These control data bits set the frame frequency of the common and segment output waveforms.

Control data			Frame frequency fo[Hz]		
FC0	FC1	FC2	Internal oscillator operating mode (The control data OC is 0, fosc=300[kHz]typ)	External clock operating mode (The control data OC is 1 and EXF is 0, f _{CK1} =300[kHz]typ)	External clock operating mode (The control data OC is 1 and EXF is 1, f _{CK2} =38[kHz]typ)
0	0	0	fosc/6144	f _{CK1} /6144	f _{CK2} /768
0	0	1	fosc/4608	f _{CK1} /4608	f _{CK2} /576
0	1	0	fosc/3072	f _{CK1} /3072	f _{CK2} /384
0	1	1	fosc/2304	f _{CK1} /2304	f _{CK2} /288
1	0	0	fosc/1536	f _{CK1} /1536	f _{CK2} /192
1	0	1	fosc/1152	f _{CK1} /1152	f _{CK2} /144
1	1	0	fosc/768	f _{CK1} /768	f _{CK2} /96

Note: When is setting (FC0,FC1,FC2)=(1,1,1), the frame frequency is same as frame frequency at the time of the (FC0,FC1,FC2)=(0,1,0) setting (fosc/3072, f_{CK1}/3072, f_{CK2}/384).

(7) OC ... Internal oscillator operating mode/external clock operating mode switching control data

This control data bit selects either the internal oscillator operating mode or external clock operating mode.

OC	Fundamental clock operating mode	I/O pin (S53/OSCI) state
0	Internal oscillator operating mode	S53
1	External clock operating mode	OSCI

Note: S53: Segment output
 OSCI: External clock input

(8) SC ... Segment on/off control data

This control data bit controls the on/off state of the segments.

SC	Display state
0	On
1	Off

Note that when the segments are turned off by setting SC to 1, the segments are turned off by outputting segment off waveforms from the segment output pins.

(9) BU ... Normal mode/power-saving mode control data

This control data bit selects either normal mode or power-saving mode.

BU	Mode
0	Normal mode
1	Power saving mode In this mode, the internal oscillator circuit stops oscillation (the S53/OSCI pin is configured for segment output) if the IC is in the internal oscillator operating mode (OC=0) and the IC stops receiving external clock signals (the S53/OSCI pin is configured for external clock input) if the IC is in the external clock operating mode (OC=1). The common and segment output pins go to the V _{SS} level. However, the S1/P1 to S4/P4 output pins can be used as general-purpose output ports under the control of the data bits P0 to P2. (The general-purpose output port P1 can not be used as clock output).

LC75829PE, LC75829PW

Display Data and Output Pin Correspondence (1/4 Duty)

Output pin	COM1	COM2	COM3	COM4	Output pin	COM1	COM2	COM3	COM4
S1/P1	D1	D2	D3	D4	S27	D105	D106	D107	D108
S2/P2	D5	D6	D7	D8	S28	D109	D110	D111	D112
S3/P3	D9	D10	D11	D12	S29	D113	D114	D115	D116
S4/P4	D13	D14	D15	D16	S30	D117	D118	D119	D120
S5	D17	D18	D19	D20	S31	D121	D122	D123	D124
S6	D21	D22	D23	D24	S32	D125	D126	D127	D128
S7	D25	D26	D27	D28	S33	D129	D130	D131	D132
S8	D29	D30	D31	D32	S34	D133	D134	D135	D136
S9	D33	D34	D35	D36	S35	D137	D138	D139	D140
S10	D37	D38	D39	D40	S36	D141	D142	D143	D144
S11	D41	D42	D43	D44	S37	D145	D146	D147	D148
S12	D45	D46	D47	D48	S38	D149	D150	D151	D152
S13	D49	D50	D51	D52	S39	D153	D154	D155	D156
S14	D53	D54	D55	D56	S40	D157	D158	D159	D160
S15	D57	D58	D59	D60	S41	D161	D162	D163	D164
S16	D61	D62	D63	D64	S42	D165	D166	D167	D168
S17	D65	D66	D67	D68	S43	D169	D170	D171	D172
S18	D69	D70	D71	D72	S44	D173	D174	D175	D176
S19	D73	D74	D75	D76	S45	D177	D178	D179	D180
S20	D77	D78	D79	D80	S46	D181	D182	D183	D184
S21	D81	D82	D83	D84	S47	D185	D186	D187	D188
S22	D85	D86	D87	D88	S48	D189	D190	D191	D192
S23	D89	D90	D91	D92	S49	D193	D194	D195	D196
S24	D93	D94	D95	D96	S50	D197	D198	D199	D200
S25	D97	D98	D99	D100	S52	D201	D202	D203	D204
S26	D101	D102	D103	D104	S53/OSCI	D205	D206	D207	D208

Note: This table assumes that pins S1/P1 to S4/P4 and S53/OSCI are configured for segment output.

For example, the table below lists the output states for the S21 output pin.

Display data				Output pin (S21) state
D81	D82	D83	D84	
0	0	0	0	The LCD segments corresponding to COM1, COM2, COM3, and COM4 are off.
0	0	0	1	The LCD segment corresponding to COM4 is on.
0	0	1	0	The LCD segment corresponding to COM3 is on.
0	0	1	1	The LCD segments corresponding to COM3 and COM4 are on.
0	1	0	0	The LCD segment corresponding to COM2 is on.
0	1	0	1	The LCD segments corresponding to COM2 and COM4 are on.
0	1	1	0	The LCD segments corresponding to COM2 and COM3 are on.
0	1	1	1	The LCD segments corresponding to COM2, COM3, and COM4 are on.
1	0	0	0	The LCD segment corresponding to COM1 is on.
1	0	0	1	The LCD segments corresponding to COM1 and COM4 are on.
1	0	1	0	The LCD segments corresponding to COM1 and COM3 are on.
1	0	1	1	The LCD segments corresponding to COM1, COM3, and COM4 are on.
1	1	0	0	The LCD segments corresponding to COM1 and COM2 are on.
1	1	0	1	The LCD segments corresponding to COM1, COM2, and COM4 are on.
1	1	1	0	The LCD segments corresponding to COM1, COM2, and COM3 are on.
1	1	1	1	The LCD segments corresponding to COM1, COM2, COM3, and COM4 are on.

LC75829PE, LC75829PW

Display Data and Output Pin Correspondence (1/3 Duty)

Output pin	COM1	COM2	COM3	Output pin	COM1	COM2	COM3
S1/P1	D1	D2	D3	S28	D82	D83	D84
S2/P2	D4	D5	D6	S29	D85	D86	D87
S3/P3	D7	D8	D9	S30	D88	D89	D90
S4/P4	D10	D11	D12	S31	D91	D92	D93
S5	D13	D14	D15	S32	D94	D95	D96
S6	D16	D17	D18	S33	D97	D98	D99
S7	D19	D20	D21	S34	D100	D101	D102
S8	D22	D23	D24	S35	D103	D104	D105
S9	D25	D26	D27	S36	D106	D107	D108
S10	D28	D29	D30	S37	D109	D110	D111
S11	D31	D32	D33	S38	D112	D113	D114
S12	D34	D35	D36	S39	D115	D116	D117
S13	D37	D38	D39	S40	D118	D119	D120
S14	D40	D41	D42	S41	D121	D122	D123
S15	D43	D44	D45	S42	D124	D125	D126
S16	D46	D47	D48	S43	D127	D128	D129
S17	D49	D50	D51	S44	D130	D131	D132
S18	D52	D53	D54	S45	D133	D134	D135
S19	D55	D56	D57	S46	D136	D137	D138
S20	D58	D59	D60	S47	D139	D140	D141
S21	D61	D62	D63	S48	D142	D143	D144
S22	D64	D65	D66	S49	D145	D146	D147
S23	D67	D68	D69	S50	D148	D149	D150
S24	D70	D71	D72	S51/COM4	D151	D152	D153
S25	D73	D74	D75	S52	D154	D155	D156
S26	D76	D77	D78	S53/OSCI	D157	D158	D159
S27	D79	D80	D81				

Note: This table assumes that pins S1/P1 to S4/P4, S51/COM4, and S53/OSCI are configured for segment output.

For example, the table below lists the output states for the S21 output pin.

Display data			Output pin (S21) state
D61	D62	D63	
0	0	0	The LCD segments corresponding to COM1, COM2, and COM3 are off.
0	0	1	The LCD segment corresponding to COM3 is on.
0	1	0	The LCD segment corresponding to COM2 is on.
0	1	1	The LCD segments corresponding to COM2 and COM3 are on.
1	0	0	The LCD segment corresponding to COM1 is on.
1	0	1	The LCD segments corresponding to COM1 and COM3 are on.
1	1	0	The LCD segments corresponding to COM1 and COM2 are on.
1	1	1	The LCD segments corresponding to COM1, COM2, and COM3 are on.

Output Waveforms (1/4-Duty 1/3-Bias Drive Scheme)

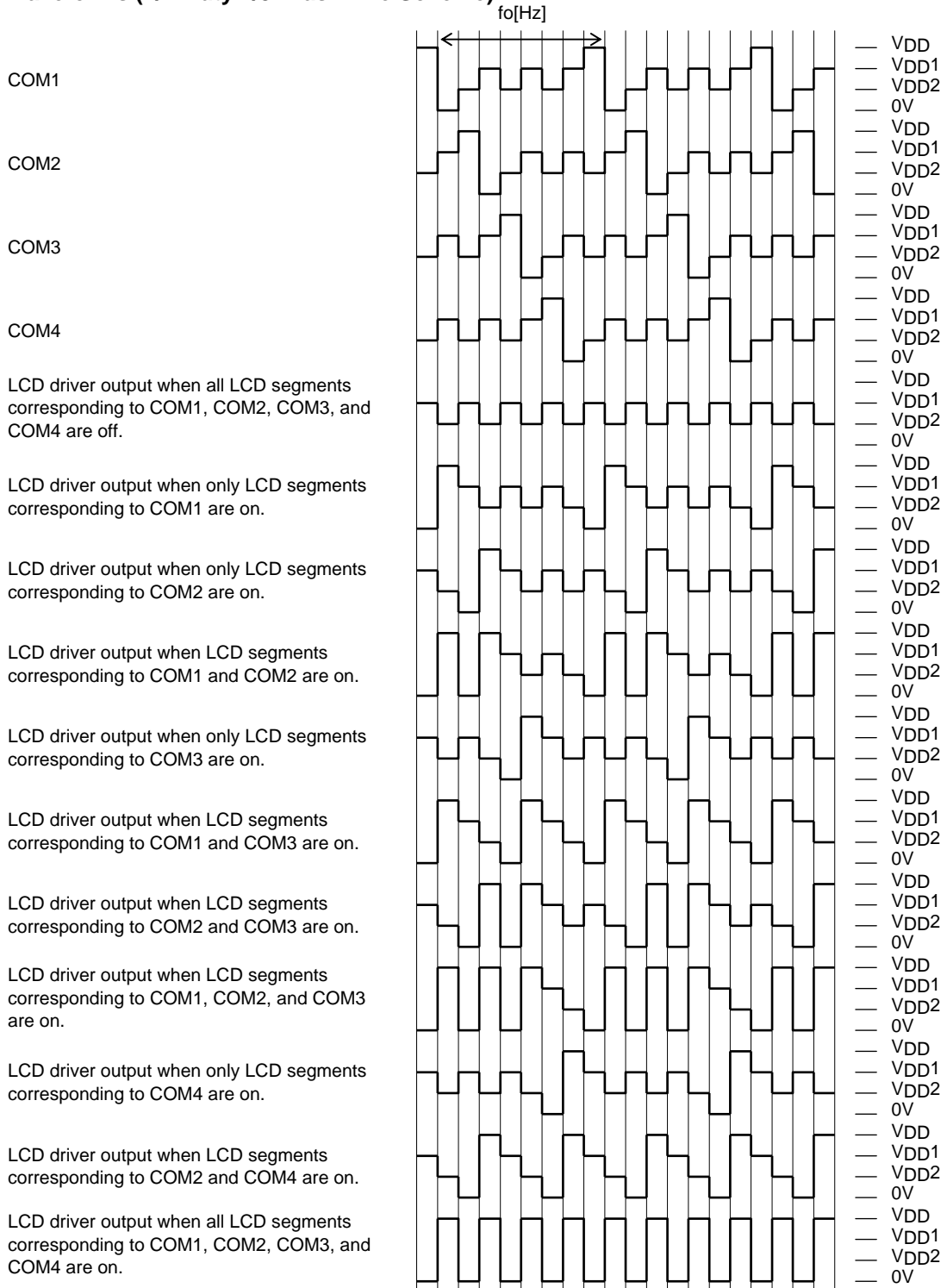

Control data			Frame frequency fo[Hz]		
FC0	FC1	FC2	Internal oscillator operating mode (The control data OC is 0, fosc=300[kHz]typ)	External clock operating mode (The control data OC is 1 and EXF is 0, fCK1=300[kHz]typ)	External clock operating mode (The control data OC is 1 and EXF is 1, fCK2=38[kHz]typ)
0	0	0	fosc/6144	fCK1/6144	fCK2/768
0	0	1	fosc/4608	fCK1/4608	fCK2/576
0	1	0	fosc/3072	fCK1/3072	fCK2/384
0	1	1	fosc/2304	fCK1/2304	fCK2/288
1	0	0	fosc/1536	fCK1/1536	fCK2/192
1	0	1	fosc/1152	fCK1/1152	fCK2/144
1	1	0	fosc/768	fCK1/768	fCK2/96

Note: When is setting (FC0,FC1,FC2)=(1,1,1), the frame frequency is same as frame frequency at the time of the (FC0,FC1,FC2)=(0,1,0) setting (fosc/3072, fCK1/3072, fCK2/384).

LC75829PE, LC75829PW

Output waveforms (1/3-Duty 1/3-Bias Drive Scheme)

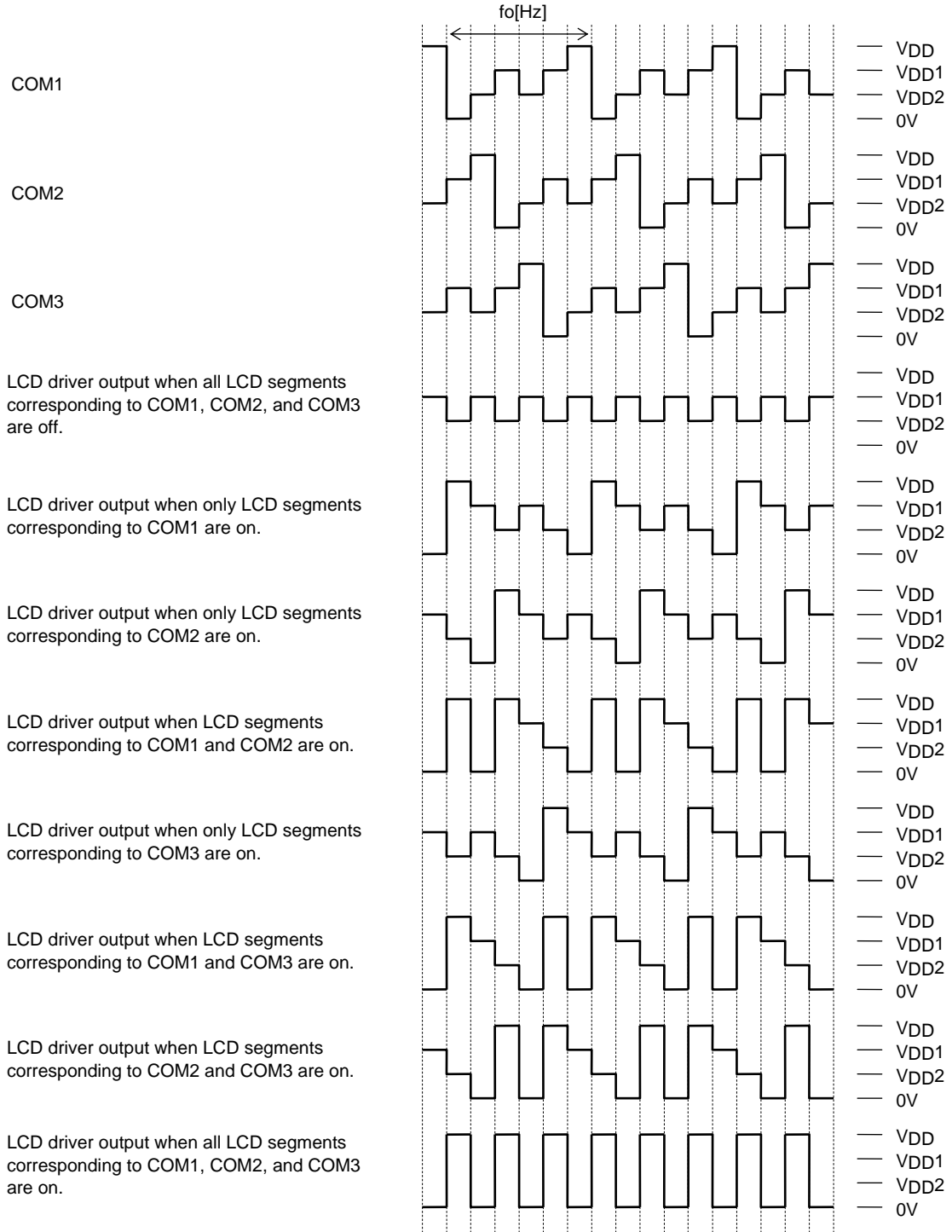

Control data			Frame frequency f_o [Hz]		
FC0	FC1	FC2	Internal oscillator operating mode (The control data OC is 0, $f_{osc}=300$ [kHz]typ)	External clock operating mode (The control data OC is 1 and EXF is 0, $f_{CK1}=300$ [kHz]typ)	External clock operating mode (The control data OC is 1 and EXF is 1, $f_{CK2}=38$ [kHz]typ)
0	0	0	$f_{osc}/6144$	$f_{CK1}/6144$	$f_{CK2}/768$
0	0	1	$f_{osc}/4608$	$f_{CK1}/4608$	$f_{CK2}/576$
0	1	0	$f_{osc}/3072$	$f_{CK1}/3072$	$f_{CK2}/384$
0	1	1	$f_{osc}/2304$	$f_{CK1}/2304$	$f_{CK2}/288$
1	0	0	$f_{osc}/1536$	$f_{CK1}/1536$	$f_{CK2}/192$
1	0	1	$f_{osc}/1152$	$f_{CK1}/1152$	$f_{CK2}/144$
1	1	0	$f_{osc}/768$	$f_{CK1}/768$	$f_{CK2}/96$

Note: When is setting (FC0,FC1,FC2)=(1,1,1), the frame frequency is same as frame frequency at the time of the (FC0,FC1,FC2)=(0,1,0) setting ($f_{osc}/3072$, $f_{CK1}/3072$, $f_{CK2}/384$).

Display Control and the $\overline{\text{INH}}$ Pin

Since the LSI internal data (1/4 duty : the display data D1 to D208 and the control data, 1/3 duty : the display data D1 to D159 and the control data) is undefined when power is first applied, applications should set the $\overline{\text{INH}}$ pin low at the same time as power is applied to turn off the display (This sets the S1/P1 to S4/P4, S5 to S50, COM1 to COM3, COM4/S51, S52, and S53/OSCI pins to the VSS level.) and during this period send serial data from the controller. The controller should then set the $\overline{\text{INH}}$ pin high after the data transfer has completed. This procedure prevents meaningless display at power on.

(See Figure 5 and Figure 6.)

• 1/4 duty

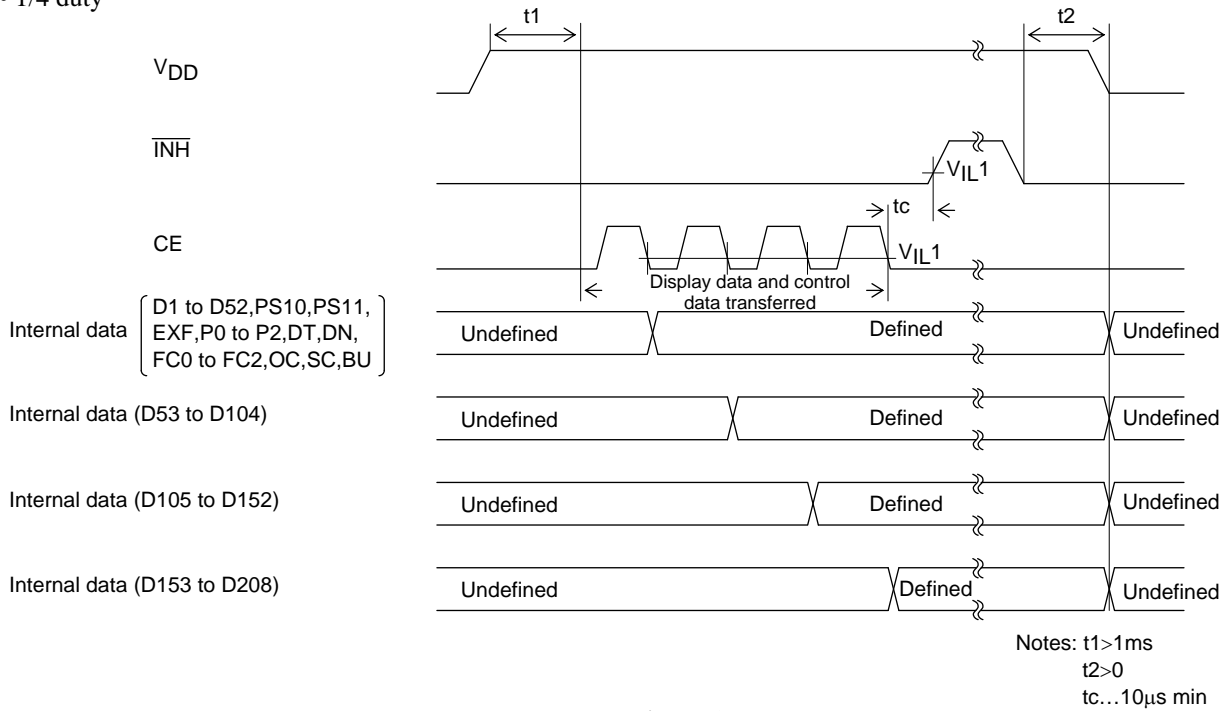

[Figure 5]

• 1/3 duty

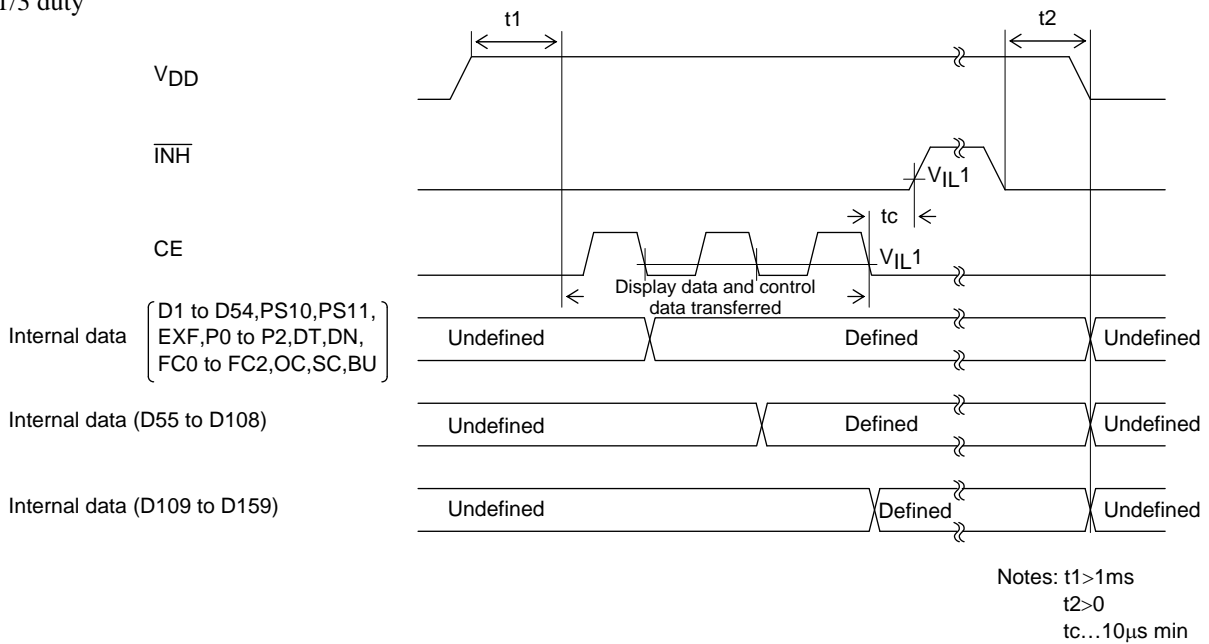

[Figure 6]

Notes on Controller Transfer of Display Data

When using the LC75829 in 1/4 duty, applications transfer the display data (D1 to D208) in four operations, and in 1/3 duty, they transfer the display data (D1 to D159) in three operations. In either case, applications should transfer all of the display data within 30 ms to maintain the quality of displayed image.

S53/OSCI Pin Peripheral Circuit

(1) Internal oscillator operating mode (control data OC = 0)

Connect the S53/OSCI pin to the LCD panel when the internal oscillator operating mode is selected.

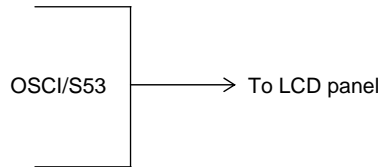

(2) External clock operating mode (control data OC = 1)

When the external clock operating mode is selected, insert a current protection resistor R_g (2.2 to 22 k Ω) between the S53/OSCI pin and external clock output pin (external oscillator). Determine the value of the resistance according to the allowable current value at the external clock output pin. Also make sure that the waveform of the external clock is not heavily distorted.

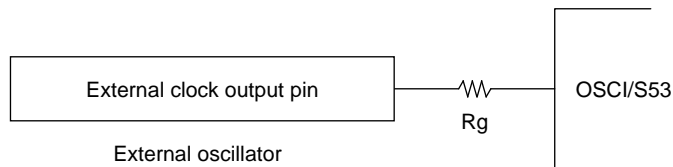

Note: Allowable current value at external clock output pin $> \frac{V_{DD}}{R_g}$

(3) Unused pin treatment

When the S53/OSCI pin is not to be used, select the internal oscillator operating mode (setting control data OC to 0) to keep the pin open.

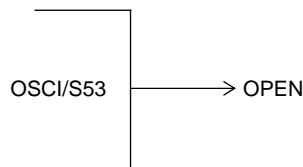

LC75829PE, LC75829PW

Sample Applications Circuit 1

1/4 Duty, 1/3 Bias

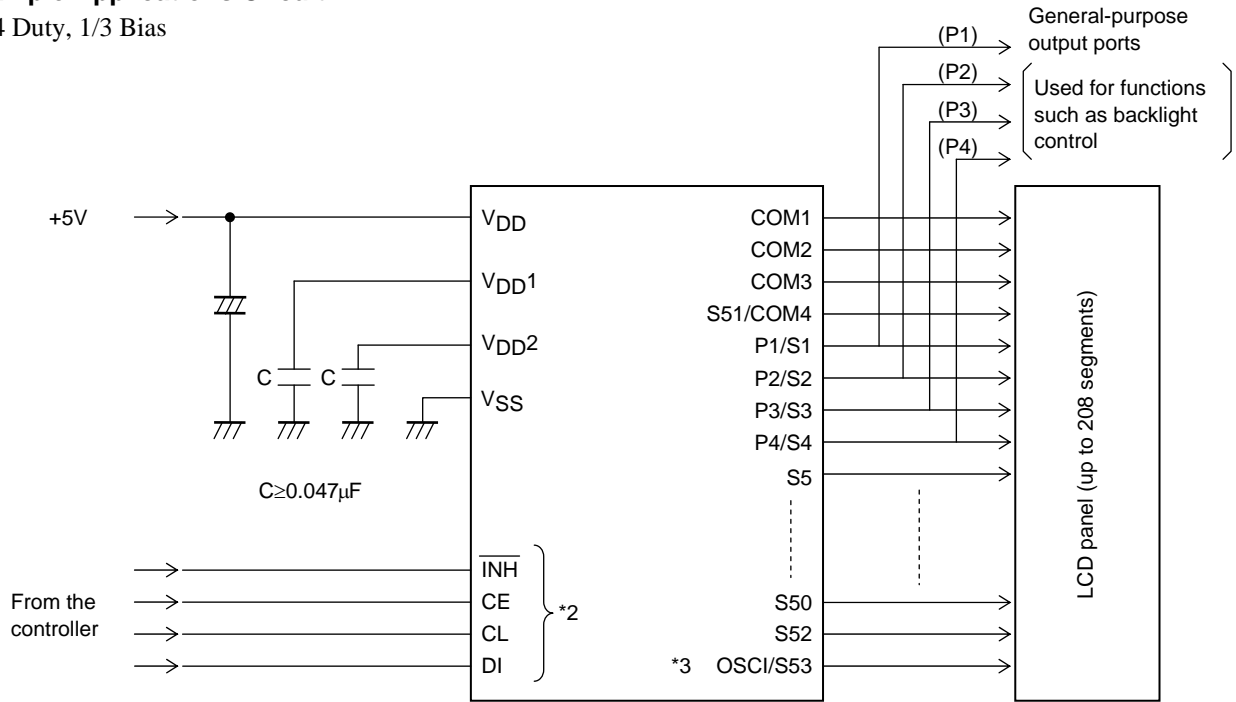

*2 The pins to be connected to the controller (CE, CL, DI, $\overline{\text{INH}}$) can handle 3.3 V or 5 V.

*3 Connect the S53/OSCI pin to the LCD panel in the internal oscillator operating mode and insert a current protection resistor R_g (2.2 to 22 kΩ) between the S53/OSCI pin and external clock output pin (external oscillator) in the external clock operating mode (see "S53/OSCI Pin Peripheral Circuit").

Sample Application Circuit 2

1/3 Duty, 1/3 Bias

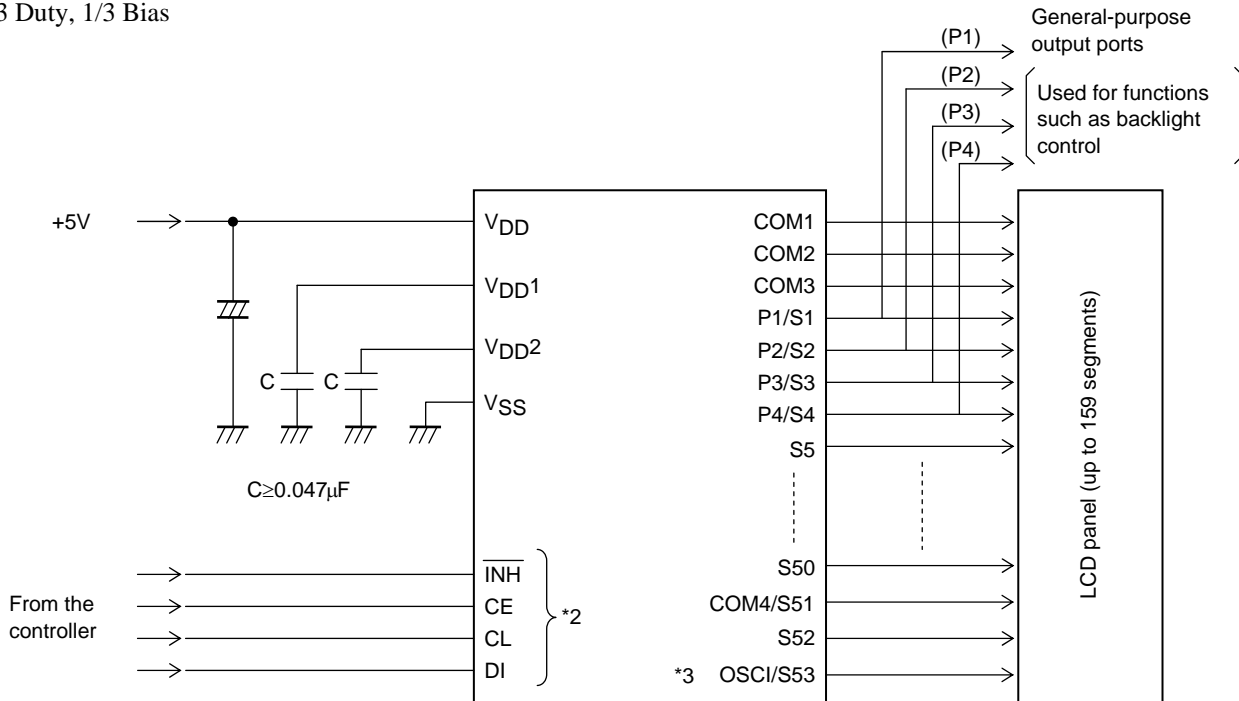

*2 The pins to be connected to the controller (CE, CL, DI, $\overline{\text{INH}}$) can handle 3.3 V or 5 V.

*3 Connect the S53/OSCI pin to the LCD panel in the internal oscillator operating mode and insert a current protection resistor R_g (2.2 to 22 kΩ) between the S53/OSCI pin and external clock output pin (external oscillator) in the external clock operating mode (see "S53/OSCI Pin Peripheral Circuit").

LC75829PE, LC75829PW

ORDERING INFORMATION



Device	Package	Shipping (Qty / Packing)
LC75829PE-H	PQFP64 14x14 / QIP64E (Pb-Free / Halogen Free)	300 / Tray Foam
LC75829PEH-H	PQFP64 14x14 / QIP64E (Pb-Free / Halogen Free)	60 / Tray Foam
LC75829PEH-TLA-H	PQFP64 14x14 / QIP64E (Pb-Free / Halogen Free)	500 / Tape & Reel
LC75829PW-H	SPQFP64 10x10 / SQFP64 (Pb-Free / Halogen Free)	800 / Tray JEDEC
LC75829PWH-H	SPQFP64 10x10 / SQFP64 (Pb-Free / Halogen Free)	50 / Tray Foam

† For information on tape and reel specifications, including part orientation and tape sizes, please refer to our Tape and Reel Packaging Specifications Brochure, BRD8011/D. http://www.onsemi.com/pub_link/Collateral/BRD8011-D.PDF

ON Semiconductor and the ON Semiconductor logo are trademarks of Semiconductor Components Industries, LLC dba ON Semiconductor or its subsidiaries in the United States and/or other countries. ON Semiconductor owns the rights to a number of patents, trademarks, copyrights, trade secrets, and other intellectual property. A listing of ON Semiconductor's product/patent coverage may be accessed at www.onsemi.com/site/pdf/Patent-Marking.pdf. ON Semiconductor reserves the right to make changes without further notice to any products herein. ON Semiconductor makes no warranty, representation or guarantee regarding the suitability of its products for any particular purpose, nor does ON Semiconductor assume any liability arising out of the application or use of any product or circuit, and specifically disclaims any and all liability, including without limitation special, consequential or incidental damages. Buyer is responsible for its products and applications using ON Semiconductor products, including compliance with all laws, regulations and safety requirements or standards, regardless of any support or applications information provided by ON Semiconductor. "Typical" parameters which may be provided in ON Semiconductor data sheets and/or specifications can and do vary in different applications and actual performance may vary over time. All operating parameters, including "Typicals" must be validated for each customer application by customer's technical experts. ON Semiconductor does not convey any license under its patent rights nor the rights of others. ON Semiconductor products are not designed, intended, or authorized for use as a critical component in life support systems or any FDA Class 3 medical devices or medical devices with a same or similar classification in a foreign jurisdiction or any devices intended for implantation in the human body. Should Buyer purchase or use ON Semiconductor products for any such unintended or unauthorized application, Buyer shall indemnify and hold ON Semiconductor and its officers, employees, subsidiaries, affiliates, and distributors harmless against all claims, costs, damages, and expenses, and reasonable attorney fees arising out of, directly or indirectly, any claim of personal injury or death associated with such unintended or unauthorized use, even if such claim alleges that ON Semiconductor was negligent regarding the design or manufacture of the part. ON Semiconductor is an Equal Opportunity/Affirmative Action Employer. This literature is subject to all applicable copyright laws and is not for resale in any manner.

Looking for pricing, stock, or lifecycle information?

Click below to explore more details on WIN SOURCE:

-  [View LC75829PEH-TLA-H on WIN SOURCE](#)
-  [ON Semiconductor](#) Information

Optimize Your Supply Chain with WIN SOURCE Solutions

-  Global Sourcing Solution
-  Obsolete Management
-  Cost Control Management
-  Shortage Management
-  Alternative Solution
-  Excess Inventory Management