

Features

- **High Density**
 - 768 to 1,024 macrocells
 - 196 to 384 I/Os
- **sysCLOCK™ PLL – Timing Control**
 - Multiply and divide factors between 1 and 32
 - Clock shifting capability ± 3.5 ns in 500ps steps
 - Multiple output frequencies
 - External feedback capability for board-level clock deskew
 - LVDS/LVPECL clock input capability
- **High Speed Logic Implementation**
 - SuperWIDE 68-input logic block
 - Up to 160 product terms per output
 - Hierarchical routing structure provides fast interconnect
- **sysIO™ Capability**
 - LVCMOS 1.8, 2.5 and 3.3
 - LVTTTL
 - SSTL 2 (I & II)
 - SSTL 3 (I & II)
 - CTT 3.3, CTT 2.5
 - HSTL (I & III)
 - PCI-X, PCI 3.3
 - GTL+
 - AGP-1X
 - 5V tolerance
 - Programmable drive strength

- **Ease of Design**

- Product term sharing
- Extensive clocking and OE capability

- **Easy System Integration**

- 3.3V power supply
- Hot socketing
- Input pull-up, pull-down or bus-keeper
- Open drain capability
- Slew rate control
- Macrocell-based power management
- IEEE 1149.1 boundary scan testable
- In-system programmable via IEEE 1532 ISC compliant interface

ispMACH 5000VG Introduction

The ispMACH 5000VG represents the third generation of Lattice's SuperWIDE CPLD architecture. Through their wide 68-input blocks, these devices give significantly improved speed performance for typical designs over architectures with fewer inputs.

The ispMACH 5000VG takes the unique benefits of the SuperWIDE architecture and extends it to higher densities referred to as SuperBIG, by using the combination of an innovative product term architecture and a two-tiered hierarchical routing architecture. Additionally, sysCLOCK and sysIO capabilities have been added to maximize system-level performance and integration.

Table 1. ispMACH 5000VG Family Selection Guide

	ispMACH 5768VG	ispMACH 51024VG
Macrocells	768	1,024
User I/O Options	196/304	304/384
t _{PD} (ns)	5.0	5.0
t _S – Set-up with 0 Hold (ns)	3.0	3.0
t _{CO} (ns)	4.4	4.4
f _{MAX} (MHz)	178	178
Supply Voltage (V)	3.3V	3.3V
Package	256-ball fpBGA 484-ball fpBGA	484-ball fpBGA 676-ball fpBGA

Figure 1. Functional Block Diagram

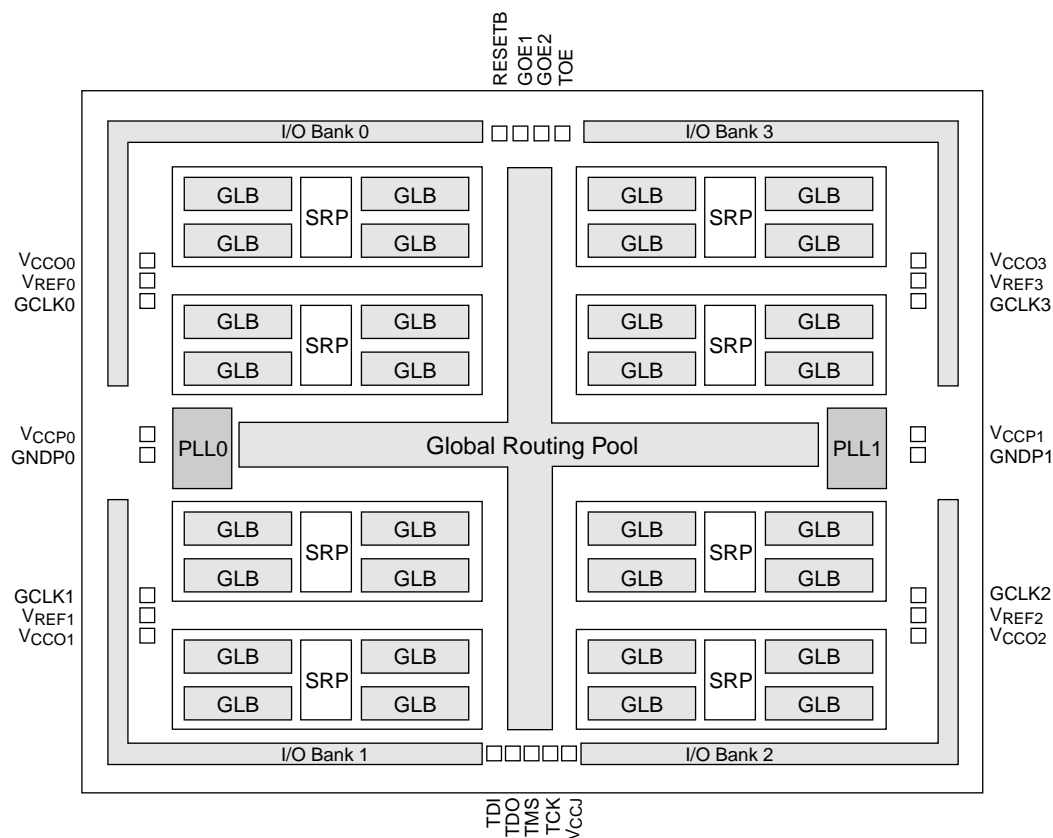

Overview

The ispMACH 5000VG devices consist of multiple SuperWIDE 68-input, 32-macrocell Generic Logic Blocks (GLBs) interconnected by a tiered routing system. Figure 1 shows the functional block diagram of the ispMACH 5000VG. Groups of four GLBs, referred to as segments, are interconnected via a Segment Routing Pool (SRP). Segments are interconnected via the Global Routing Pool (GRP.) Together the GLBs and the routing pools allow designers to create large designs in a single device without compromising performance.

Each GLB has 68 inputs coming from the SRP and contains 163 product terms. These product terms form groups of five product term clusters, which feed the PT sharing array or the macrocell directly. The ispMACH 5000VG allows up to 160 product terms to be connected to a single macrocell via the product term expanders and PT Sharing Array.

The macrocell is designed to provide flexible clocking and control functionality with the capability to select between global, product term and block-level resources. The outputs of the macrocells are fed back into the switch matrices and, if required, the sysIO cell.

All I/Os in the ispMACH 5000VG family are sysIOs, which are split into four banks. Each bank has a separate I/O power supply and reference voltage. The sysIO cells allow operation with a wide range of today's emerging interface standards. Within a bank, inputs can be set to a variety of standards, providing the reference voltage requirements of the chosen standards are compatible. Within a bank, the outputs can be set to differing standards, providing the I/O power supply voltage and the reference voltage requirements of the chosen standard are compatible. Support for this wide range of standards allows designers to achieve significantly higher board-level performance compared to the more traditional LVCMOS standards.

The ispMACH5000VG devices also contain sysCLOCK Phase Locked Loops (PLLs) that provide designers with increased clocking flexibility. The PLLs can be used to synthesize new clocks for use on-chip or elsewhere within the system. They can also be used to deskew clocks, again both at the chip and system levels. A variable delay line capability further improves this and allows designers to retard or advance the clock in order to tune set-up and clock-to-out times for optimal results. The ispMACH 5000VG Family Selection Guide (Table 1) details the key attributes and packages for the ispMACH 5000VG devices.

ispMACH 5000VG Architecture

The ispMACH 5000VG Family of In-System Programmable High Density Logic Devices is based on segments containing four Generic Logic Blocks (GLBs) and a hierarchical routing pool (GRP) structure interconnecting the segments. A segment routing pool (SRP) connects each GLB in a segment allowing the maximum flexibility and speed.

Outputs from the GLBs drive the Segment Routing Pool (SRP) and the Global Routing Pool (GRP). Enhanced switching resources are provided to allow signals in the Segment Routing Pool to drive any or all the GLBs in the segment. Optimal switching is provided to allow all signals in the Global Routing Pool to be routed to any or all SRPs. This mechanism allows fast, efficient connections across the entire device.

Segment

Each segment contains four GLBs and a segment routing pool (SRP). Each GLB has 32 internal feedback outputs and 16 external feedback outputs, for a total of 48 outputs from each GLB feeding the SRP. The SRP contains up to 384 signals, 48 from each GLB and 192 from the GRP, with full routing capability. This routing scheme maximizes the flexibility and speed of the device without sacrificing the routing.

Figure 2. Segment

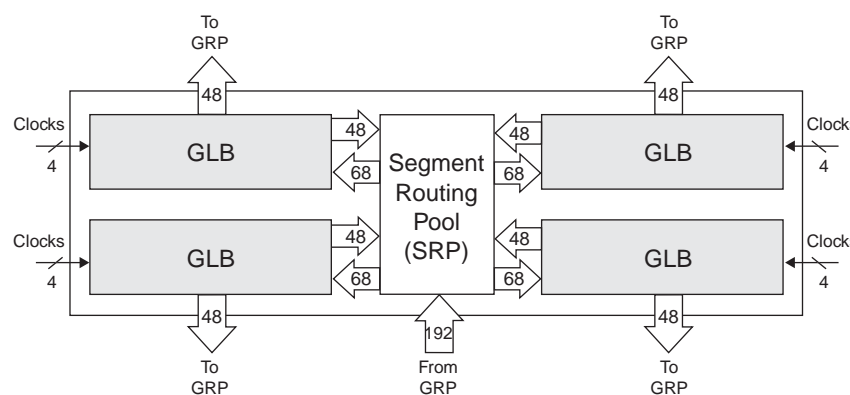

Generic Logic Block

Each GLB contains 32 macrocells and a fully populated, programmable AND-array with 160 logic product terms and three control product terms. The GLB has 68 inputs from the Segment Routing Pool, which are available in both true and complement form for every product term. The three control product terms are used for shared reset, clock and output enable functions. Figure 3 shows the structure of the GLB from the macrocell perspective. This is referred to as a macrocell slice. There are 32 macrocell slices per GLB.

AND-Array

The programmable AND-Array consists of 68 inputs and 163 output product terms. The 68 inputs from the SRP are used to form 136 lines in the AND-Array (true and complement of the inputs). Each line in the array can be connected to any of the 163 output product terms via a wired AND. Each of the 160 logic product terms feed the Dual-OR Array with the remaining three control product terms feeding the Shared PT Clock, Shared PT Reset and Shared PT OE. Every set of five product terms from the 160 logic product terms forms a product term cluster start-

Figure 3. Macrocell Slice

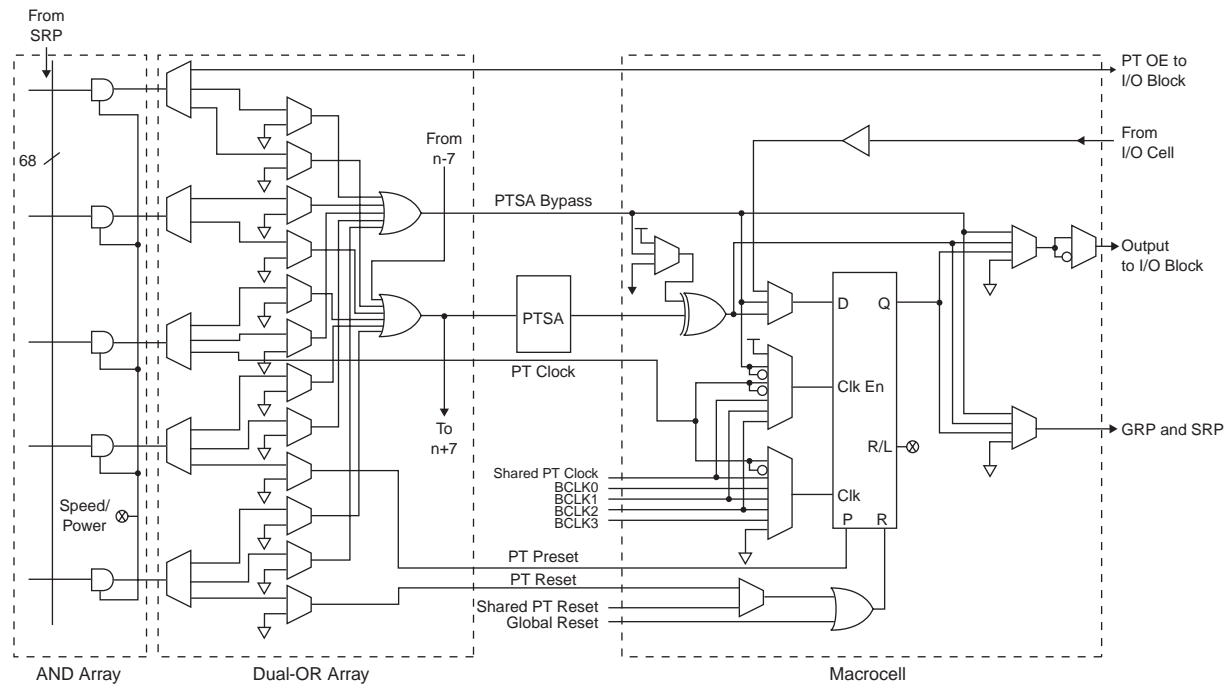
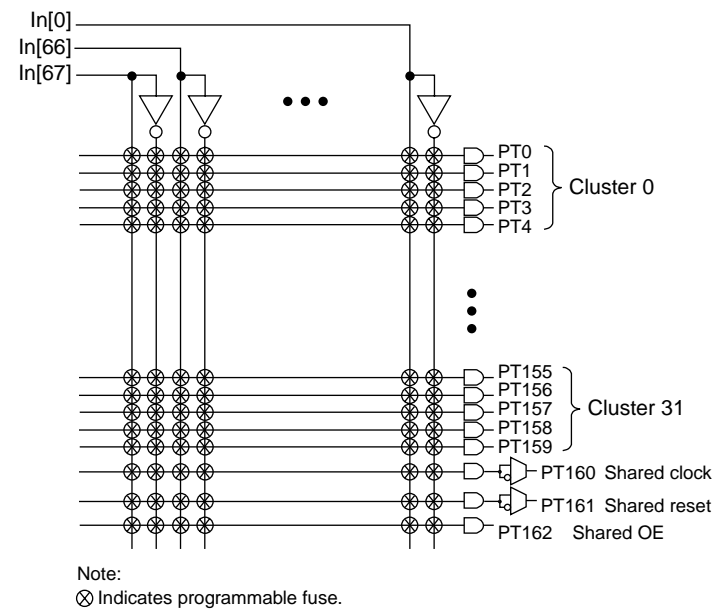

Figure 4. AND-Array



ing with PT0. There is one product term cluster for every macrocell in the GLB. In addition to the three control product terms, the first, third, fourth and fifth product terms of each cluster can be used as a PTOE (output macrocells only), PT Clock, PT Preset and PT Reset, respectively. Figure 4 is a graphical representation of the AND-Array.

Enhanced Dual-OR Array

To facilitate logic functions requiring a very large number of product terms, the ispMACH 5000VG architecture has been enhanced with an innovative product term expander capability. This capability is embedded in the Dual-OR Array. The Dual-OR Array consists of 64 OR gates. There are two OR gates per macrocell in the GLB. These OR gates are referred to as the Expandable PTSA OR gate and the PTSA-Bypass OR gate.

The PTSA-Bypass OR gate receives its five inputs from the combination of product terms associated with the product term cluster. The PTSA-Bypass OR gate feeds the macrocell directly for fast narrow logic. The Expandable PTSA OR gate receives five inputs from the combination of product terms associated with the product term cluster. It also receives an additional input from the Expanded PTSA OR gate of the N-7 macrocell, where N is the number of the macrocell associated with the current OR gate. The Expandable PTSA OR gate feeds the PTSA for sharing with other product terms and the N+7 Expandable PTSA OR gate. This allows cascading of multiple OR gates for wide functions. There is a small timing adder for each level of expansion. Figure 5 is a graphical representation of the Enhanced Dual-OR Array.

Figure 5. Enhanced Dual-OR Array

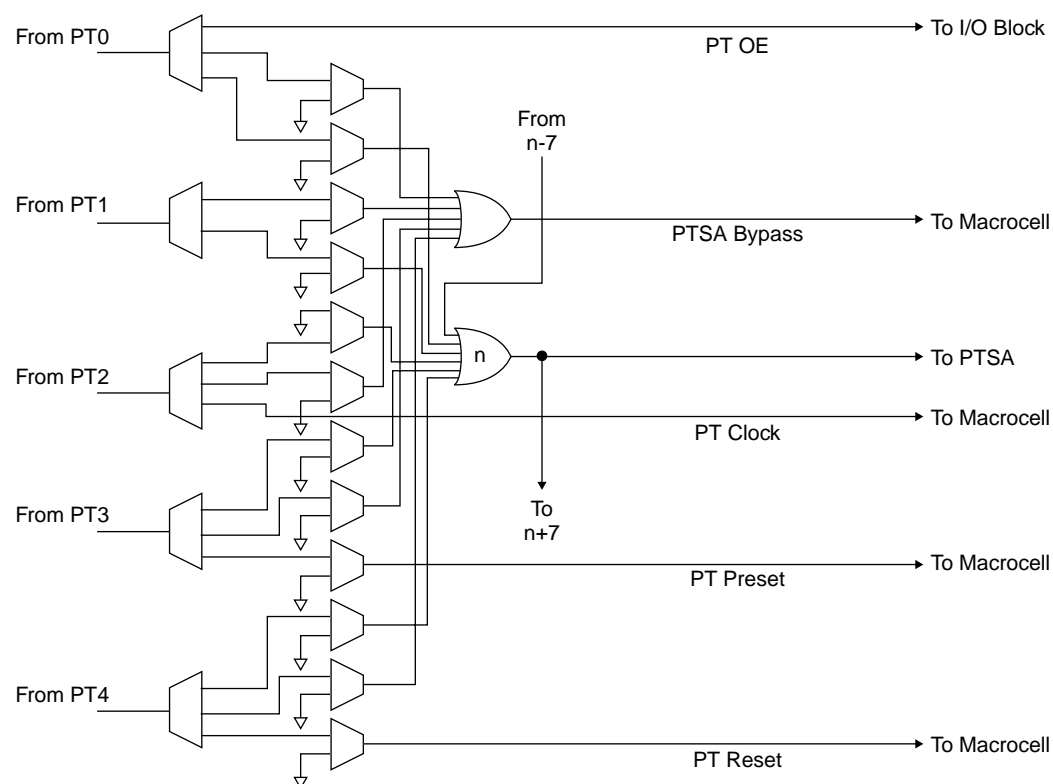

Product Term Sharing Array

The Product Term Sharing Array (PTSA) consists of 32 inputs from the Dual-OR Array (Expandable PTSA OR) and 32 outputs directly to the macrocells. Each output is the OR term of any combination of the seven Expandable PTSA OR terms connected to that output. Every Nth macrocell is connected to N-3, N-2, N-1, N, N+1, N+2 and N+3 PTSA OR terms via a programmable connection. This wraps around the logic, Macrocell 0 gets its logic from 29, 30, 31, 0, 1, 2, 3. The Expandable PTSA OR used in conjunction with the PTSA allows wide functions to be implemented easily and efficiently. Without using the Expandable PTSA OR capability, the greatest number of product terms that can be included in a single function with one pass of delay is 35. Figure 6 shows the graphical representation of the PTSA.

Figure 6. Product Term Sharing Array

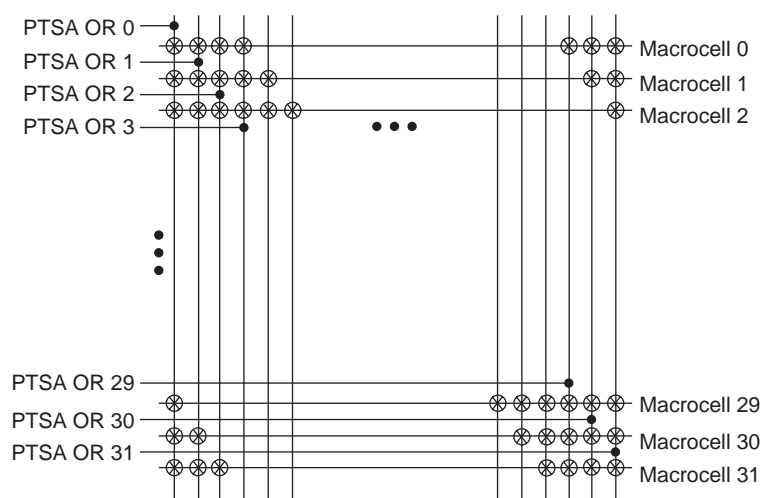

Macrocell

The 32 registered macrocells in the GLB are driven by the 32 outputs from the PTSA or the PTSA bypass. Each macrocell contains a programmable XOR gate, a programmable register/latch flip-flop and the necessary clocks and control logic to allow combinatorial or registered operation.

The macrocells each have two outputs, which can be fed to the SRP, GRP and I/O cell. This dual or concurrent output capability from the macrocell gives efficient use of the hardware resources. One output can be a registered function for example, while the other output can be an unrelated combinatorial function. A direct register input from the I/O cell facilitates efficient use of the macrocell to construct high-speed input registers.

Macrocell registers can be clocked from one of several global or product term clocks available on the device. A global and product term clock enable is also provided, eliminating the need to gate the clock to the macrocell registers directly. Reset and preset for the macrocell register is provided from both global and product term signals. The macrocell register can be programmed to operate as a D-type register or a D-type latch. Figure 7 is a graphical representation of the ispMACH 5000VG macrocell.

Figure 7. Macrocell

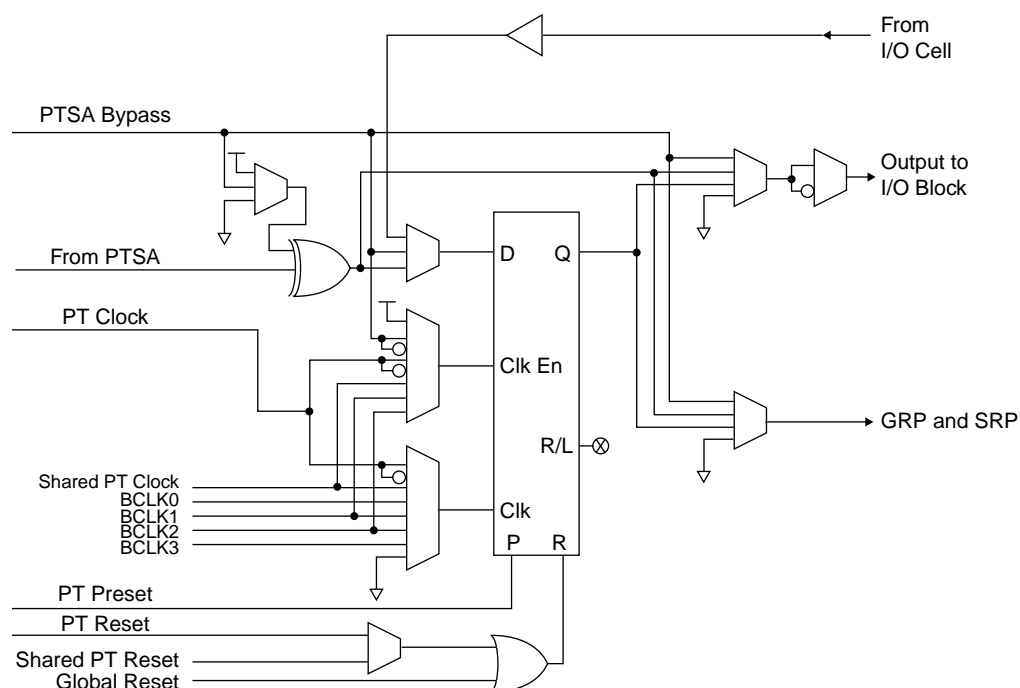

I/O Cell

The I/O cell of the ispMACH 5000VG device provides a high degree of flexibility. It includes the sysIO feature and an enhanced output enable MUX for optimal performance both on- and off-chip. The sysIO feature allows I/O cells to be configured to different I/O standards, drive strengths and slew rates. The enhanced output enable MUX provides up to 14 different output enable choices per I/O cell.

The I/O cell contains an output enable (OE) MUX, a programmable tri-state output buffer, a programmable input buffer, a programmable pull-up resistor, a programmable pull-down resistor and a programmable bus-keeper latch. The I/O cell receives its input from its associated macrocell. The I/O cell has a feedback line to its associated macrocell and a direct path to the GRP and SRP.

The output enable (OE) MUX selects the OE signal per I/O cell. The inputs to the OE MUX are the four Shared PTOE signals, PTOE and the two GOE signals. The OE MUX also has the ability to choose either the true or inverse of each of these signals. The output of the OE MUX goes through a logical AND with the TOE signal to allow easy tri-stating of the outputs for testing purposes.

The four shared PTOE signals are derived from PT163 of each GLB in the segment. The PTOE signal is derived from the first product term in each macrocell cluster, which is directly routed to the OE MUX. Therefore, every I/O cell can have a different OE signal. Figure 8 is a graphical representation of the I/O cell.

Figure 8. I/O Cell

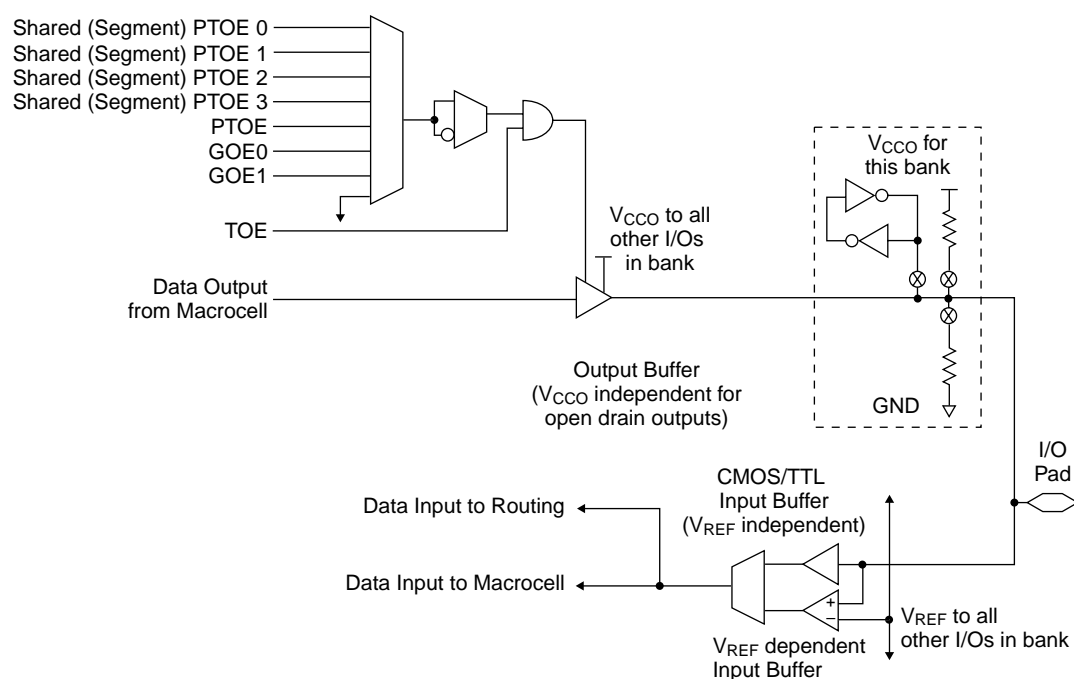

sysIO Capability

The ispMACH 5000VG devices are divided into four sysIO banks, where each bank is capable of supporting 14 different I/O standards. Each sysIO bank has its own I/O supply voltage (V_{CCO}) and reference voltage (V_{REF}) resources allowing each bank complete independence from the others. Each I/O within a bank is individually configurable based on the V_{CCO} and V_{REF} settings. Table 2 lists the sysIO standards with the typical values for V_{CCO} , V_{REF} and V_{TT} .

Table 2. ispMACH 5000VG Supported I/O Standards

sysIO Standard	V_{CCO}	V_{REF}	V_{TT}
LVTTTL	3.3V	N/A	N/A
LVC MOS-3.3	3.3V	N/A	N/A
LVC MOS-2.5	2.5V	N/A	N/A
LVC MOS-1.8	1.8V	N/A	N/A
PCI 3.3	3.3V	N/A	N/A
PCI-X	3.3V	N/A	N/A
AGP-1X	3.3V	N/A	N/A
SSTL3, Class I & II	3.3V	1.5V	1.5V
SSTL2, Class I & II	2.5V	1.25V	1.25V
CTT 3.3	3.3V	1.5V	1.5V
CTT 2.5	2.5V	1.25V	1.25V
HSTL, Class I	1.5V	0.75V	0.75V
HSTL, Class III	1.5V	0.9V	1.5V
GTL+	N/A	1.0V	1.5V
LVPECL, Differential ¹	N/A	N/A	N/A
LVDS ¹	N/A	N/A	N/A

1. LVDS and LVPECL are only supported on the dedicated clock pins.

Global clock pins have additional capabilities that allow for higher performance applications. Two global clock pins can be paired together to create a single global clock pin that can interface with certain differential signals.

The TOE and JTAG pins of the ispMACH 5000VG device are the only pins that do not have sysIO capabilities. These pins only support the LVTTTL and LVCMOS standards.

There are three classes of I/O interface standards that are implemented in the ispMACH 5000VG devices. The first is the unterminated, single-ended interface. It includes the 3.3V LVTTTL standard along with the 1.8V, 2.5V and 3.3V LVCMOS interface standards. Additionally, PCI 3.3, PCI-X and AGP-1X are all subsets of this type of interface.

The second type of interface implemented is the terminated, single-ended interface standard. This group of interfaces includes different versions of SSTL and HSTL interfaces along with CTT and GTL+. Usage of these particular I/O interfaces requires the use of an additional VREF signal. At the system level, a termination voltage, VTT, is also required. Typically, an output will be terminated to VTT at the receiving end of the transmission line it is driving.

The final types of interfaces implemented are the differential standards LVDS and LVPECL. These interfaces are implemented on clock pins only. When using one of the differential standards, a pair of global clock pins (GCLK0 and GCLK1 or GCLK3 and GCLK2) is combined to create a single clock signal.

For more information on the sysIO capability, please refer to Technical Note TN1000: *ispMACH 5000VG sysIO Design and Usage Guidelines*.

GLB Clock Distribution

The ispMACH 5000VG family has four dedicated clock input pins: GCLK0-GCLK3. GCLK0 and GCLK3 can be routed through a PLL circuit or routed directly to the internal clock nets. The internal clock nets (CLK0-CLK3) are directly related to the dedicated clock pins (see Secondary Clock Divider exception when using the sysCLOCK circuit). These feed the GLB clock multiplexes which generate the GLB clock signals (BCLK0-BCLK3). The GLB clock multiplexer allows a variety of true and complementary versions of the clocks to be used within the GLB. Each block clock can be the true or inverse of its associated global clock or the inverse of the adjacent global clock. Figure 9 shows the clock distribution network.

Figure 9. Clock Distribution Network

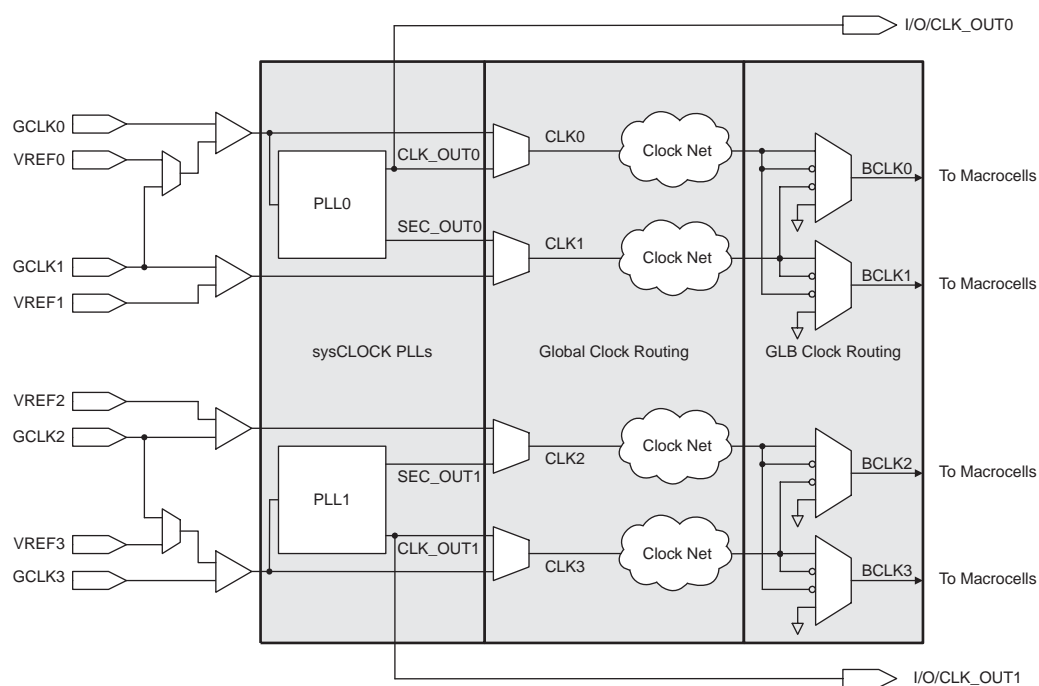

sysCLOCK PLL

The sysCLOCK PLL circuitry consists of Phase-Lock Loops (PLLs) and the various dividers, reset and feedback signals associated with the PLLs. This feature gives the user the ability to synthesize clock frequencies and generate multiple clock signals for routing within the device. Furthermore, it can generate clock signals that are deskewed either at the board level or the device level.

The ispMACH 5000VG devices provide two PLL circuits. PLL0 receives its clock inputs from GCLK 0 and provides outputs to CLK 0 (CLK 1 when using the secondary clock). PLL1 operates with signals from GCLK 3 and CLK 3 (CLK 2 when using the secondary clock). The PLL outputs (CLK_OUT) are routed via a dedicated net to a dedicated pad. Further the buffers at these dedicated pads are regular I/O buffers that can select either the I/O macrocell or the CLK_OUT (CLK_OUT0/CLK_OUT1) signal. The CLK_OUT nets are not routed through the GRP. Additionally, there are two sets of signals used for external control. Each PLL has a set of PLL_RST, PLL_FBK and PLL_LOCK signals. Figure 10 shows the ispMACH 5000VG PLL block diagram.

Figure 10. PLL Block Diagram

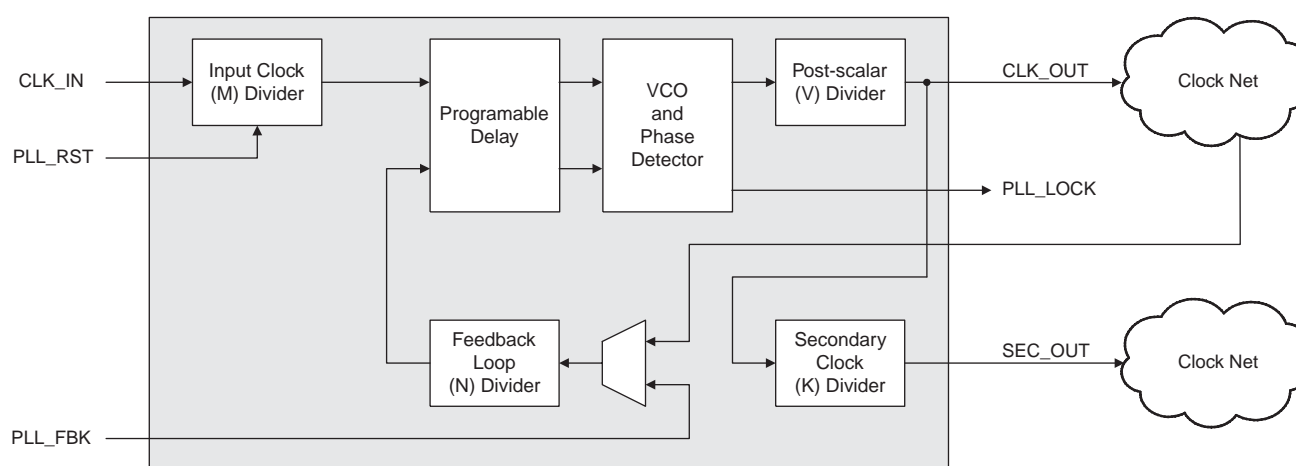

In order to facilitate the multiply and divide capabilities of the PLL, each PLL has dividers associated with it: M, N and K. The M divider is used to divide the clock signal, while the N divider is used to multiply the clock signal. The K divider is only used when a secondary clock output is needed. This divider divides the primary clock output and feeds to a separate global clock net. The V divider is used to provide lower frequency output clocks, while maintaining a stable, high frequency output from the PLL's VCO circuit.

The PLL also has a delay feature that allows the output clock to be advanced or delayed to improve set-up and clock-to-out times for better performance. This operates by inserting delay on the input or feedback lines in 0.5ns increments from 0 to 3.5ns. For more information on the PLL, please refer to Technical Note TN1003: *ispMACH 5000VG PLL Usage Guidelines*.

Power Management

The ispMACH 5000VG devices provide unique power management controls. The devices have two power settings, high power and low power, on a per node basis. Low power consumption is approximately 50% of high power consumption with a timing delay adder (tLP) to the routing delay of the low power node. Each node can be configured as either high power or low power. However, care should be taken when sharing product terms between nodes with different power settings.

The ispMACH 5000VG devices also have a power-off feature for unused product terms. By default, any product term that is not used is configured as such. This allows the device to operate at minimal power consumption without affecting the timing of the design. For more information on power management, please refer to Technical Note TN1002: *Power Estimation in ispMACH 5000VG Devices*.

IEEE 1149.1-Compliant Boundary Scan Testability

All ispMACH 5000VG devices have boundary scan cells and are compliant to the IEEE 1149.1 standard. This allows functional testing of the circuit board on which the device is mounted through a serial scan path that can access all critical logic nodes. Internal registers are linked internally, allowing test data to be shifted in and loaded directly onto test nodes, or test node data to be captured and shifted out for verification. In addition, these devices can be linked into a board-level serial scan path for more board-level testing. The test access port has its own supply voltage and can operate with LVCMOS3.3, 2.5 and 1.8V standards.

sysIO Quick Configuration

To facilitate the most efficient board test, the physical nature of the I/O cells must be set before running any continuity tests. As these tests are fast, by nature, the overhead and time that is required for configuration of the I/Os' physical nature should be minimal so that board test time is minimized. The ispMACH 5000VG family of devices allows this by offering the user the ability to quickly configure the physical nature of the sysIO cells. This quick configuration takes milliseconds to complete, whereas it takes seconds for the entire device to be programmed. Lattice's ispVM™ System programming software can either perform the quick configuration through the PC parallel port, or can generate the ATE or test vectors necessary for a third-party test system.

IEEE 1532-Compliant In-System Programming

In-system programming of devices provides a number of significant benefits including rapid prototyping, lower inventory levels, higher quality and the ability to make in-field modifications. All ispMACH 5000VG devices provide In-System Programming (ISP™) capability through their Boundary Scan Test Access Port. This capability has been implemented in a manner that ensures that the port remains compliant to the IEEE 1532 standard. By using IEEE 1532 as the communication interface through which ISP is achieved, customers get the benefit of a standard, well-defined interface.

The ispMACH 5000VG devices can be programmed across the commercial temperature and voltage range. The PC-based Lattice software facilitates in-system programming of ispMACH 5000VG devices. The software takes the JEDEC file output produced by the design implementation software, along with information about the scan chain, and creates a set of vectors used to drive the scan chain. The software can use these vectors to drive a scan chain via the parallel port of a PC. Alternatively, the software can output files in formats understood by common automated test equipment. This equipment can then be used to program ispMACH 5000VG devices during the testing of a circuit board.

Security Bit

A programmable security bit is provided on the ispMACH 5000VG devices as a deterrent to unauthorized copying of the array configuration patterns. Once programmed, this bit prevents readback of the programmed pattern by a device programmer, securing proprietary design from competitors. The security bit also prevents programming and verification. The entire device must be erased in order to erase the security bit.

Hot Socketing

The ispMACH 5000VG devices are well suited for those applications that require hot socketing capability. Hot socketing a device requires that the device, when powered down, can tolerate active signals on the I/Os and inputs without being damaged. Additionally, it requires that the effects of the powered-down device be minimal on active signals.

Density Migration

The ispMACH 5000 family has been designed to ensure that different density devices in the same package have the same pin-out. Furthermore, the architecture ensures a high success rate when performing design migration from lower density parts to higher density parts. In many cases, it is possible to shift a lower utilization design targeted for a high density device to a lower density device. However, the exact details of the final resource utilization will impact the likely success in each case.

Absolute Maximum Ratings^{1, 2, 3}

Supply Voltage (V_{CC})	-0.5 to 5.4V
PLL Supply Voltage (V_{CCP})	-0.5 to 5.4V
Output Supply Voltage (V_{CCO})	-0.5 to 5.4V
Input Voltage Applied ⁴	-0.5 to 5.6V
Tri-state Output Voltage Applied	-0.5 to 5.6V
Storage Temperature	-65 to 150°C
Junction Temperature (T_j) with Power Applied	-55 to 130°C

1. Stress above those listed under the "Absolute Maximum Ratings" may cause permanent damage to the device. Functional operation of the device at these or any other conditions above those indicated in the operational sections of this specification is not implied.
2. Compliance with Lattice *Thermal Management* document is required.
3. All voltages referenced to GND.
4. Overshoot and Undershoot of -2V to ($V_{IH} (MAX)+2$) volts is permitted for a duration of < 20ns.

Recommended Operating Conditions

Symbol	Parameter	Min	Max	Units
V_{CC}	Supply Voltage	3.0	3.6	V
V_{CCP}	Supply Voltage for PLL block	3.0	3.6	V
V_{CCJ}	Supply Voltage for IEEE1149.1 Test Access Port	1.65	3.6	V
T_j (Commercial)	Junction Commercial Operation	0	90	C
T_j (Industrial)	Junction Industrial Operation	-40	105	C

Note: V_{CCJ} must be set in appropriate range to be compatible with desired LVCMOS standard.

Erase Reprogram Specifications

Parameter	Min	Max	Units
Erase/Reprogram Cycle	1000	—	Cycles

Hot Socketing Characteristics^{1,2,3}

Symbol	Parameter	Condition	Min	Typ	Max	Units
I_{DK}	Input or I/O Leakage Current	$0 \leq V_{IN} \leq V_{IH} (MAX)$	—	—	+/-100	μA
		$V_{IH} (MAX) \leq V_{IN} \leq 5.5V$	—	—	+/-100	μA

1. Insensitive to sequence of V_{CC} and V_{CCO} . However, assumes monotonic rise / fall rates for V_{CC} and V_{CCO} .
2. LVTTTL, LVCMOS only
3. $0 < V_{CC} \leq V_{CC} (MAX)$, $0 < V_{CCO} \leq V_{CCO} (MAX)$

DC Electrical Characteristics

Over Recommended Operating Conditions

Symbol	Parameter	Condition	Min	Typ	Max	Units	
I_{IL}, I_{IH}^1	Input or I/O Leakage Current	$0V \leq V_{IN} \leq V_{IH} (MAX)$	—	—	+/-10	μA	
I_{PU}^2	I/O Weak Pull-up Resistor Current	$0 \leq V_{IN} \leq 0.7 V_{CCO}$	$V_{CCO} = 3.3$	-30	—	-150	μA
			$V_{CCO} = 2.5$	-20	—	-150	μA
			$V_{CCO} = 1.8$	-10	—	-150	μA
I_{PD}^2	I/O Weak Pull-down Resistor Current	$V_{IL} (MAX) \leq V_{IN} \leq V_{IH} (MAX)$	30	—	150	μA	
I_{BHLS}^2	Bus Hold Low Sustaining Current	$V_{IN} = V_{IL} (MAX)$	30	—	—	μA	
I_{BHHS}^2	Bus Hold High Sustaining Current	$V_{IN} = 0.7 V_{CCO}$	$V_{CCO} = 3.3$	-30	—	—	μA
			$V_{CCO} = 2.5$	-20	—	—	μA
			$V_{CCO} = 1.8$	-10	—	—	μA
I_{BHLO}^2	Bus Hold Low Overdrive Current	$0V \leq V_{IN} \leq V_{IH} (MAX)$	—	—	150	μA	
I_{BHHO}^2	Bus Hold High Overdrive Current	$0V \leq V_{IN} \leq V_{IH} (MAX)$	—	—	-150	μA	
$I_{CC}^{3,4,5}$	Operating Power Supply Current	$V_{CC} = 3.3V$	—	380	—	mA	
V_{BHT}	Bus Hold Trip Points		$V_{IL} (MAX)$	—	$V_{IH} (MIN)$	V	
C_1	I/O Capacitance ³	$V_{CC} = 3.3V, V_{IO} = 0 \text{ to } V_{IH} (MAX)$	—	10	—	pf	
		$V_{CCO} = 3.3V, 2.5, 1.8, 1.5$					
C_2	Clock Capacitance ³	$V_{CC} = 3.3V, V_{IO} = 0 \text{ to } V_{IH} (MAX)$	—	10	—	pf	
		$V_{CCO} = 3.3V, 2.5, 1.8, 1.5$					
C_3	Global Input Capacitance ³	$V_{CC} = 3.3V, V_{IO} = 0 \text{ to } V_{IH} (MAX)$	—	10	—	pf	
		$V_{CCO} = 3.3V, 2.5, 1.8, 1.5$					

1. Input or I/O leakage current is measured with the pin configured as an input or as an I/O with the output driver tri-stated. It is not measured with the output driver active. Bus maintenance circuits are disabled.

2. Only available for LVCMOS and LVTTL standards.

3. $T_A = 25^\circ C$, $f = 1.0MHz$.

4. Device configured with 16-bit counters.

5. I_{CC} varies with specific device configuration and operating frequency.

sysIO Recommended Operating Conditions²

Standard	V _{CCO} (V)		V _{REF} (V)	
	Min	Max	Min	Max
LVC MOS 3.3 ¹	3.0	3.6	—	—
LVC MOS 2.5	2.3	2.7	—	—
LVC MOS 1.8	1.65	1.95	—	—
LV TTL	3.0	3.6	—	—
PCI 3.3	3.0	3.6	—	—
PCI-X	3.0	3.6	—	—
AGP-1X	3.15	3.45	—	—
SSTL 2	2.3	2.7	1.15	1.35
SSTL 3	3.0	3.6	1.3	1.7
CTT 3.3	3.0	3.6	1.35	1.65
CTT 2.5	2.3	2.7	1.35	1.65
HSTL	1.4	1.6	0.68	0.9
GTL+	1.4	3.6	0.882	1.122

1. Software default setting.

2. Typical values for V_{CCO} and V_{REF} are the average of the Min and Max values.

sysIO DC Electrical Characteristics

Over Recommended Operating Conditions

Standard	V_{IL}		V_{IH}		V_{OL} Max (V)	V_{OH} Min (V)	I_{OL}^2 (mA)	I_{OH}^2 (mA)
	Min (V)	Max (V)	Min (V)	Max (V)				
LVC MOS 3.3 ¹	-0.3	0.8	2.0	5.5	0.4	2.4	20	-20
LVC MOS 3.3	-0.3	0.8	2.0	5.5	0.4	2.4	16, 12, 8, 5.33, 4	-16, -12, -8, -5.33, -4
					0.2	$V_{CCO} - 0.2$	0.1	-0.1
LV TTL	-0.3	0.8	2.0	5.5	0.4	2.4	20	-20
					0.2	$V_{CCO} - 0.2$	0.1	-0.1
LVC MOS 2.5	-0.3	0.7	1.7	3.6	0.4	$V_{CCO} - 0.4$	16, 12, 8, 5.33, 4	-16, -12, -8, -5.33, -4
					0.2	$V_{CCO} - 0.2$	0.1	-0.1
LVC MOS 1.8	-0.3	$0.35V_{CCO}$	$0.65V_{CCO}$	3.6	0.4	$V_{CCO} - 0.4$	12, 8, 5.33, 4	-12, -8, -5.33, -4
					0.2	$V_{CCO} - 0.2$	0.1	-0.1
PCI 3.3	-0.3	$0.3V_{CCO}$	$0.5V_{CCO}$	3.6	$0.1V_{CCO}$	$0.9V_{CCO}$	1.5	-0.5
PCI-X	-0.3	$0.35V_{CCO}$	$0.5V_{CCO}$	3.6	$0.1V_{CCO}$	$0.9V_{CCO}$	1.5	-0.5
AGP-1X	-0.3	$0.3V_{CCO}$	$0.5V_{CCO}$	3.6	$0.1V_{CCO}$	$0.9V_{CCO}$	1.5	-0.5
SSTL3 class I	-0.3	$V_{REF} - 0.2$	$V_{REF} + 0.2$	3.6	0.7	$V_{CCO} - 1.1$	8	-8
SSTL3 class II	-0.3	$V_{REF} - 0.2$	$V_{REF} + 0.2$	3.6	0.5	$V_{CCO} - 0.9$	16	-16
SSTL2 class I	-0.3	$V_{REF} - 0.18$	$V_{REF} + 0.18$	3.6	0.54	$V_{CCO} - 0.62$	7.6	-7.6
SSTL2 class II	-0.3	$V_{REF} - 0.18$	$V_{REF} + 0.18$	3.6	0.35	$V_{CCO} - 0.43$	15.2	-15.2
CTT 3.3	-0.3	$V_{REF} - 0.2$	$V_{REF} + 0.2$	3.6	$V_{REF} - 0.4$	$V_{REF} + 0.4$	8	-8
CTT 2.5	-0.3	$V_{REF} - 0.2$	$V_{REF} + 0.2$	3.6	$V_{REF} - 0.4$	$V_{REF} + 0.4$	8	-8
HSTL class I	-0.3	$V_{REF} - 0.1$	$V_{REF} + 0.1$	3.6	0.4	$V_{CCO} - 0.4$	8	-8
HSTL class III	-0.3	$V_{REF} - 0.1$	$V_{REF} + 0.1$	3.6	0.4	$V_{CCO} - 0.4$	24	-8
GTL+	-0.3	$V_{REF} - 0.2$	$V_{REF} + 0.2$	3.6	0.6	n/a	36	n/a

1. Software default setting

2. The average DC current drawn by I/Os between adjacent bank GND connections, or between the last GND in an I/O bank and the end of the I/O bank, as shown in the logic signals connection table, shall not exceed 96mA.

sysIO Differential Input DC Electrical Characteristics and Operating Conditions

Symbol	Parameter	Test Conditions	Min	Max
$V_{INP} \cdot V_{INM}$	LVDS Input voltage	—	0	2.4
V_{THD}	LVDS Differential input threshold	—	$\pm 100\text{mV}$	—
V_{IL}	LVPECL Input Voltage Low	$V_{CC} = 3.0$ to 3.6V	$V_{CC} - 1.81$	$V_{CC} - 1.48$
		$V_{CC} = 3.3\text{V}$	1.49V	1.83V
V_{IH}	LVPECL Input Voltage High	$V_{CC} = 3.0$ to 3.6V	$V_{CC} - 1.17$	$V_{CC} - 0.88$
		$V_{CC} = 3.3\text{V}$	2.14V	2.42V

ispMACH 5768VG External Switching Characteristics

Over Recommended Operating Conditions

Parameter	Description ^{1,2,3}	-5		-75		-10		-12		Units
		Min	Max	Min	Max	Min	Max	Min	Max	
t _{PD}	Data propagation delay, 5-PT bypass	—	5.0	—	7.5	—	10.0	—	12.0	ns
t _{PD_PTSA}	Data propagation delay, intrasegment path	—	6.0	—	9.0	—	11.5	—	13.5	ns
t _{PD_GLOBAL}	Data propagation delay, intersegment path	—	6.5	—	9.75	—	13.0	—	16.0	ns
t _S	GLB register setup time before clock, 5-PT bypass	3.0	—	5.0	—	7.5	—	9.3	—	ns
t _{S_PTSA}	GLB register setup time before clock	3.0	—	6.0	—	8.5	—	10.0	—	ns
t _{SIR}	GLB register setup time before clock, input register path	2.8	—	3.0	—	4.0	—	5.0	—	ns
t _H	GLB register hold time before clock, 5-PT bypass	0.0	—	0.0	—	0.0	—	0.0	—	ns
t _{H_PTSA}	GLB register hold time before clock	0.0	—	0.0	—	0.0	—	0.0	—	ns
t _{HIR}	GLB register hold time before clock, input reg. path	0.0	—	0.0	—	0.0	—	0.0	—	ns
t _{CO}	GLB register clock-to-output delay	—	4.4	—	5.0	—	6.0	—	7.0	ns
t _R	External reset pin to output delay	—	6.5	—	9.0	—	10.0	—	10.9	ns
t _{RW}	External reset pulse duration	4.0	—	6.0	—	8.0	—	9.5	—	ns
t _{LPTOE/DIS}	Input to output local product term output enable/disable	—	7.0	—	9.75	—	11.5	—	13.4	ns
t _{SPTOE/DIS}	Input to output segment product term output enable/disable	—	8.0	—	11.25	—	17.5	—	20.4	ns
t _{GOE/DIS}	Global OE input to output enable/disable	—	6.2	—	7.5	—	8.85	—	10.0	ns
t _{CW}	Global clock width, high or low	1.6	—	2.75	—	3.6	—	4.3	—	ns
t _{GW}	Global gate width low (for low transparent) or high (for high transparent)	1.8	—	2.75	—	3.6	—	4.3	—	ns
t _{WIR}	Input register clock width, high or low	1.8	—	2.75	—	3.6	—	4.3	—	ns
t _{SKEW}	Clock-to-out skew, block level	—	0.25	—	0.35	—	0.45	—	0.55	ns
	Clock-to-out skew, segment level	—	0.4	—	0.5	—	0.6	—	0.7	ns
f _{MAX} ⁴	Clock frequency with internal feedback	178.6	—	117.0	—	87.0	—	73.0	—	MHz
f _{MAX} (Ext.)	Clock frequency with external feedback, 1/ (t _{S_PTSA} + t _{CO})	135.1	—	90.9	—	69.0	—	58.8	—	MHz
f _{MAX} (Tog.)	Clock frequency max Toggle	312.5	—	181.0	—	138.0	—	116.0	—	MHz

Timing v.1.20

1. Timing numbers are based on default LVCMOS 3.3 I/O Buffers. Use timing adjusters provided to calculate timing for other standards.
2. Measured using standard switching circuit, assuming segment and global routing loading of 1, worst case PTSA loading and 1 output switching.
3. Pulse widths and clock widths less than minimum will cause unknown behavior.
4. Standard 16-bit counter using SRP feedback.

ispMACH 51024VG External Switching Characteristics

Over Recommended Operating Conditions

Parameter	Description ^{1,2,3}	-5		-75		-10		-12		Units
		Min	Max	Min	Max	Min	Max	Min	Max	
t _{PD}	Data propagation delay, 5-PT bypass	—	5.0	—	7.5	—	10.0	—	12.0	ns
t _{PD_PTSA}	Data propagation delay, intrasegment path	—	6.0	—	9.0	—	11.5	—	13.5	ns
t _{PD_GLOBAL}	Data propagation delay, intersegment path	—	6.5	—	9.75	—	13.0	—	16.0	ns
t _S	GLB register setup time before clock, 5-PT bypass	3.0	—	5.0	—	7.5	—	9.3	—	ns
t _{S_PTSA}	GLB register setup time before clock	3.0	—	6.0	—	8.5	—	10.0	—	ns
t _{SIR}	GLB register setup time before clock, input register path	2.8	—	3.0	—	4.0	—	5.0	—	ns
t _H	GLB register hold time before clock, 5-PT bypass	0.0	—	0.0	—	0.0	—	0.0	—	ns
t _{H_PTSA}	GLB register hold time before clock	0.0	—	0.0	—	0.0	—	0.0	—	ns
t _{HIR}	GLB register hold time before clock, input reg. path	0.0	—	0.0	—	0.0	—	0.0	—	ns
t _{CO}	GLB register clock-to-output delay	—	4.4	—	5.0	—	6.0	—	7.0	ns
t _R	External reset pin to output delay	—	6.5	—	9.0	—	10.0	—	10.9	ns
t _{RW}	External reset pulse duration	4.0	—	6.0	—	8.0	—	9.5	—	ns
t _{LPTOE/DIS}	Input to output local product term output enable/disable	—	7.0	—	9.75	—	11.5	—	13.4	ns
t _{SPTOE/DIS}	Input to output segment product term output enable/disable	—	8.0	—	11.25	—	17.5	—	20.4	ns
t _{GOE/DIS}	Global OE input to output enable/disable	—	6.2	—	7.5	—	8.85	—	10.0	ns
t _{CW}	Global clock width, high or low	1.6	—	2.75	—	3.6	—	4.3	—	ns
t _{GW}	Global gate width low (for low transparent) or high (for high transparent)	1.8	—	2.75	—	3.6	—	4.3	—	ns
t _{WIR}	Input register clock width, high or low	1.8	—	2.75	—	3.6	—	4.3	—	ns
t _{SKEW}	Clock-to-out skew, block level	—	0.25	—	0.35	—	0.45	—	0.55	ns
	Clock-to-out skew, segment level	—	0.4	—	0.5	—	0.6	—	0.7	ns
f _{MAX} ⁴	Clock frequency with internal feedback	178.6	—	117.0	—	87.0	—	73.0	—	MHz
f _{MAX} (Ext.)	Clock frequency with external feedback, 1/ (t _{S_PTSA} + t _{CO})	135.1	—	90.9	—	69.0	—	58.8	—	MHz
f _{MAX} (Tog.)	Clock frequency max Toggle	312.5	—	181.0	—	138.0	—	116.0	—	MHz

Timing v.1.10

1. Timing numbers are based on default LVCMOS 3.3 I/O Buffers. Use timing adjusters provided to calculate timing for other standards.
2. Measured using standard switching circuit, assuming segment and global routing loading of 1, worst case PTSA loading and 1 output switching.
3. Pulse widths and clock widths less than minimum will cause unknown behavior.
4. Standard 16-bit counter using SRP feedback.

Timing Model

The task of determining the timing through the ispMACH 5000VG family, like any CPLD, is relatively simple. The timing model provided in Figure 11 shows the specific delay paths. Once the implementation of a given function is determined either conceptually or from the software report file, the delay path of the function can easily be determined from the timing model. The Lattice design tools report the timing delays based on the same timing model for a particular design. Note that the internal timing parameters are given for reference only, and are not tested. The external timing parameters are tested and guaranteed for every device. For more information on the timing model and usage, please refer to Technical Note TN1001: *ispMACH 5000VG Timing Model Design and Usage Guidelines*.

Figure 11. ispMACH 5000VG Timing Model

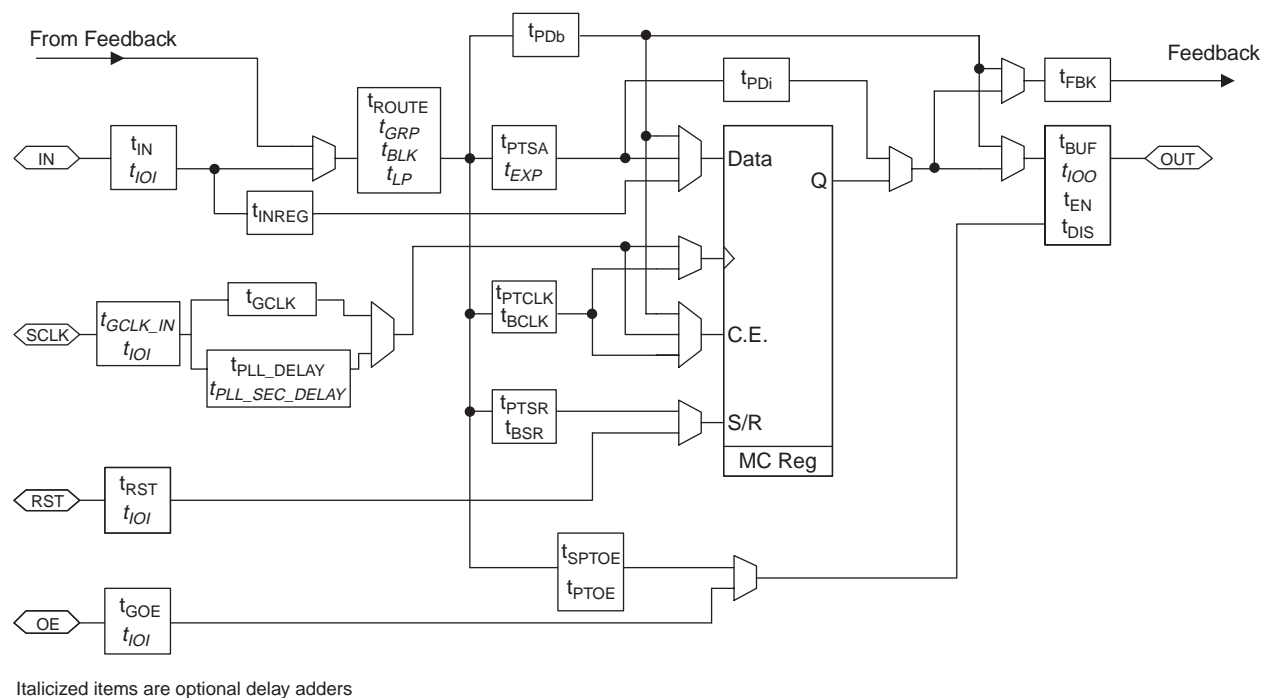

ispMACH 5768VG Internal Timing Parameters

Over Recommended Operating Conditions

Parameter	Description	-5		-75		-10		-12		Units
		Min	Max	Min	Max	Min	Max	Min	Max	
In/Out Delays										
t _{IN}	Input Buffer Delay	—	0.65	—	0.95	—	1.25	—	1.40	ns
t _{GCLK_IN}	Global Clock Input Buffer Delay	—	0.65	—	0.95	—	1.25	—	1.40	ns
t _{GOE}	Global OE Pin Delay	—	4.05	—	5.00	—	6.00	—	7.00	ns
t _{BUF}	Delay through Output Buffer	—	1.15	—	1.50	—	1.75	—	1.90	ns
t _{EN}	Output Enable Time	—	2.15	—	2.50	—	2.85	—	3.00	ns
t _{DIS}	Output Disable Time	—	2.15	—	2.50	—	2.85	—	3.00	ns
t _{RSTb}	Global RESETbar Pin Delay	—	4.60	—	6.50	—	7.00	—	7.50	ns
Routing Delays										
t _{ROUTE}	Delay through SRP	—	2.80	—	4.20	—	5.65	—	6.90	ns
t _{PTSA}	Product Term Sharing Array Delay	—	0.40	—	1.85	—	2.35	—	2.50	ns
t _{PDB}	5-PT Bypass Propagation Delay	—	0.40	—	0.85	—	1.35	—	1.80	ns
t _{PDi}	Macrocell Propagation Delay	—	1.00	—	0.50	—	0.50	—	0.80	ns
t _{INREG}	Input Buffer to Macrocell Register Delay	—	3.00	—	3.05	—	3.50	—	4.40	ns
t _{FBK}	Internal Feedback Delay	—	0.00	—	0.00	—	0.00	—	0.00	ns
t _{GCLK}	Global Clock Tree Delay	—	0.85	—	0.70	—	0.55	—	0.65	ns
t _{PLL_DELAY}	Programmable PLL Delay Increment	—	0.50	—	0.50	—	0.50	—	0.50	ns
t _{PLL_SEC_DELAY}	Additional Delay When Using Secondary PLL Output	—	0.60	—	0.60	—	0.60	—	0.60	ns
t _{GRP}	Global Routing Pool Delay	—	1.50	—	2.25	—	3.00	—	4.00	ns
Register/Latch Delays										
t _S	D-Register Setup Time	0.65	—	0.65	—	1.05	—	1.25	—	ns
t _{S_PT}	D-Register Setup Time with PT Clock	0.65	—	0.65	—	1.05	—	1.25	—	ns
t _H	D-Register Hold Time	0.00	—	0.00	—	0.00	—	0.00	—	ns
t _{ST}	T-Register Setup Time	1.15	—	1.15	—	1.55	—	1.75	—	ns
t _{ST_PT}	T-Register Setup Time with PT Clock	1.15	—	1.15	—	1.55	—	1.75	—	ns
t _{HT}	T-Register Hold Time	0.00	—	0.00	—	0.00	—	0.00	—	ns
t _{COi}	Register Clock to Output/Feedback MUX Time	—	1.75	—	1.85	—	2.45	—	3.05	ns
t _{CES}	Clock Enable Setup Time	2.60	—	3.90	—	5.05	—	5.95	—	ns
t _{CEH}	Clock Enable Hold Time	0.60	—	0.90	—	1.20	—	1.45	—	ns
t _{SL}	Latch Setup Time	2.80	—	4.20	—	5.50	—	6.60	—	ns
t _{SL_PT}	Latch Setup Time with PT Clock	2.80	—	4.20	—	5.50	—	6.60	—	ns
t _{HL}	Latch Hold Time	0.00	—	0.00	—	0.00	—	0.00	—	ns
t _{GOi}	Latch Gate to Output/Feedback MUX Time	—	1.75	—	2.50	—	3.50	—	4.50	ns
t _{PDLi}	Propagation Delay through Transparent Latch to Output/Feedback MUX	—	2.40	—	3.50	—	4.00	—	4.50	ns
t _{SRI}	Asynchronous Reset or Set to Output/Feedback MUX Delay	—	0.75	—	1.00	—	1.25	—	1.50	ns
t _{SRR}	Asynchronous Reset or Set Recovery Delay	—	1.00	—	1.50	—	2.00	—	2.50	ns
Control Delays										
t _{BCLK}	GLB PT Clock Delay	—	3.10	—	4.65	—	6.00	—	7.00	ns
t _{PTCLK}	Macrocell PT Clock Delay	—	3.00	—	4.50	—	6.00	—	7.00	ns

ispMACH 5768VG Internal Timing Parameters (Continued)

Over Recommended Operating Conditions

Parameter	Description	-5		-75		-10		-12		Units
		Min	Max	Min	Max	Min	Max	Min	Max	
t _{BSR}	Block PT Set/Reset Delay	—	2.00	—	3.00	—	4.00	—	4.80	ns
t _{PTSR}	Macrocell PT Set/Reset Delay	—	2.00	—	3.00	—	4.00	—	4.80	ns
t _{SPTOE}	Segment PT OE Delay	—	2.40	—	3.60	—	7.75	—	9.10	ns
t _{PTOE}	Macrocell PT OE Delay	—	1.40	—	2.10	—	1.75	—	2.10	ns

Notes:

Timing v.1.20

1. Internal Timing Parameters are not tested and are for reference only. Refer to Timing Model in this data sheet for further details.
2. t_{PLL_DELAY} is the unit increment by which the clock signal can be incremented. The PLL can adjust the clock signal by up to 3.5ns in either direction in units of 0.5ns for each step.

ispMACH 51024VG Internal Timing Parameters

Over Recommended Operating Conditions

Parameter	Description	-5		-75		-10		-12		Units
		Min	Max	Min	Max	Min	Max	Min	Max	
In/Out Delays										
t _{IN}	Input Buffer Delay	—	0.65	—	0.95	—	1.25	—	1.40	ns
t _{GCLK_IN}	Global Clock Input Buffer Delay	—	0.65	—	0.95	—	1.25	—	1.40	ns
t _{GOE}	Global OE Pin Delay	—	4.05	—	5.00	—	6.00	—	7.00	ns
t _{BUF}	Delay through Output Buffer	—	1.15	—	1.50	—	1.75	—	1.90	ns
t _{EN}	Output Enable Time	—	2.15	—	2.50	—	2.85	—	3.00	ns
t _{DIS}	Output Disable Time	—	2.15	—	2.50	—	2.85	—	3.00	ns
t _{RSTb}	Global RESETbar Pin Delay	—	4.60	—	6.50	—	7.00	—	7.50	ns
Routing Delays										
t _{ROUTE}	Delay through SRP	—	2.80	—	4.20	—	5.65	—	6.90	ns
t _{PTSA}	Product Term Sharing Array Delay	—	0.40	—	1.85	—	2.35	—	2.50	ns
t _{PDB}	5-PT Bypass Propagation Delay	—	0.40	—	0.85	—	1.35	—	1.80	ns
t _{PDi}	Macrocell Propagation Delay	—	1.00	—	0.50	—	0.50	—	0.80	ns
t _{INREG}	Input Buffer to Macrocell Register Delay	—	3.00	—	3.05	—	3.50	—	4.40	ns
t _{FBK}	Internal Feedback Delay	—	0.00	—	0.00	—	0.00	—	0.00	ns
t _{GCLK}	Global Clock Tree Delay	—	0.85	—	0.70	—	0.55	—	0.65	ns
t _{PLL_DELAY}	Programmable PLL Delay Increment	—	0.50	—	0.50	—	0.50	—	0.50	ns
t _{PLL_SEC_DELAY}	Additional Delay When Using Secondary PLL Output	—	0.60	—	0.60	—	0.60	—	0.60	ns
t _{GRP}	Global Routing Pool Delay	—	1.50	—	2.25	—	3.00	—	4.00	ns
Register/Latch Delays										
t _S	D-Register Setup Time	0.65	—	0.65	—	1.05	—	1.25	—	ns
t _{S_PT}	D-Register Setup Time with PT Clock	0.65	—	0.65	—	1.05	—	1.25	—	ns
t _H	D-Register Hold Time	0.00	—	0.00	—	0.00	—	0.00	—	ns
t _{ST}	T-Register Setup Time	1.15	—	1.15	—	1.55	—	1.75	—	ns
t _{ST_PT}	T-Register Setup Time with PT Clock	1.15	—	1.15	—	1.55	—	1.75	—	ns
t _{HT}	T-Register Hold Time	0.00	—	0.00	—	0.00	—	0.00	—	ns
t _{COi}	Register Clock to Output/Feedback MUX Time	—	1.75	—	1.85	—	2.45	—	3.05	ns

ispMACH 51024VG Internal Timing Parameters (Continued)

Over Recommended Operating Conditions

Parameter	Description	-5		-75		-10		-12		Units
		Min	Max	Min	Max	Min	Max	Min	Max	
t _{CES}	Clock Enable Setup Time	2.60	—	3.90	—	5.05	—	5.95	—	ns
t _{CEH}	Clock Enable Hold Time	0.60	—	0.90	—	1.20	—	1.45	—	ns
t _{SL}	Latch Setup Time	2.80	—	4.20	—	5.50	—	6.60	—	ns
t _{SL_PT}	Latch Setup Time with PT Clock	2.80	—	4.20	—	5.50	—	6.60	—	ns
t _{HL}	Latch Hold Time	0.00	—	0.00	—	0.00	—	0.00	—	ns
t _{GOi}	Latch Gate to Output/Feedback MUX Time	—	1.75	—	2.50	—	3.50	—	4.50	ns
t _{PDLi}	Propagation Delay through Transparent Latch to Output/Feedback MUX	—	2.40	—	3.50	—	4.00	—	4.50	ns
t _{SRI}	Asynchronous Reset or Set to Output/Feedback MUX Delay	—	0.75	—	1.00	—	1.25	—	1.50	ns
t _{SRR}	Asynchronous Reset or Set Recovery Delay	—	1.00	—	1.50	—	2.00	—	2.50	ns
Control Delays										
t _{BCLK}	GLB PT Clock Delay	—	3.10	—	4.65	—	6.00	—	7.00	ns
t _{PTCLK}	Macrocell PT Clock Delay	—	3.00	—	4.50	—	6.00	—	7.00	ns
t _{BSR}	Block PT Set/Reset Delay	—	2.00	—	3.00	—	4.00	—	4.80	ns
t _{PTSR}	Macrocell PT Set/Reset Delay	—	2.00	—	3.00	—	4.00	—	4.80	ns
t _{SPTOE}	Segment PT OE Delay	—	2.40	—	3.60	—	7.75	—	9.10	ns
t _{PTOE}	Macrocell PT OE Delay	—	1.40	—	2.10	—	1.75	—	2.10	ns

Notes:

Timing v.1.10

1. Internal Timing Parameters are not tested and are for reference only. Refer to Timing Model in this data sheet for further details.
2. t_{PLL_DELAY} is the unit increment by which the clock signal can be incremented. The PLL can adjust the clock signal by up to 3.5ns in either direction in units of 0.5ns for each step.

ispMACH 5768VG Timing Adders

Adder Type	Base Parameter	Description	-5		-75		-10		-12		Units
			Min	Max	Min	Max	Min	Max	Min	Max	
t _{BLA}	t _{ROUTE}	GLB Loading Adder	—	0.0	—	0.0	—	0.0	—	0.0	ns
t _{EXP}	t _{PTSA}	PT Expander Adder	—	1.5	—	2.0	—	2.5	—	2.5	ns
t _{LP}	t _{ROUTE}	Low Power Adder	—	1.5	—	1.5	—	1.5	—	1.5	ns
t_{IOI} Input Adders											
LVC MOS18_in	t _{IN} , t _{GCLK_IN} , t _{RSTb} , t _{GOE}	Using LVC MOS1.8 standard	—	0.90	—	0.90	—	0.90	—	0.90	ns
LVC MOS25_in	t _{IN} , t _{GCLK_IN} , t _{RSTb} , t _{GOE}	Using LVC MOS2.5 standard	—	0.15	—	0.15	—	0.15	—	0.15	ns
LVC MOS33_in	t _{IN} , t _{GCLK_IN} , t _{RSTb} , t _{GOE}	Using LVC MOS3.3 standard	—	0.0	—	0.0	—	0.0	—	0.0	ns
LV TTL	t _{IN} , t _{GCLK_IN} , t _{RSTb} , t _{GOE}	Using LV TTL standard	—	0.0	—	0.0	—	0.0	—	0.0	ns
PCI_in	t _{IN} , t _{GCLK_IN} , t _{RSTb} , t _{GOE}	Using PCI standard	—	0.0	—	0.0	—	0.0	—	0.0	ns
PCI_X_in	t _{IN} , t _{GCLK_IN} , t _{RSTb} , t _{GOE}	Using PCI_X standard	—	0.0	—	0.0	—	0.0	—	0.0	ns
AGP_1X_in	t _{IN} , t _{GCLK_IN} , t _{RSTb} , t _{GOE}	Using AGP-1X standard	—	0.0	—	0.0	—	0.0	—	0.0	ns
SSTL3_I_in	t _{IN} , t _{GCLK_IN} , t _{RSTb} , t _{GOE}	Using SSTL3_I standard	—	1.00	—	1.00	—	1.00	—	1.00	ns
SSTL3_II_in	t _{IN} , t _{GCLK_IN} , t _{RSTb} , t _{GOE}	Using SSTL3_II standard	—	1.00	—	1.00	—	1.00	—	1.00	ns
SSTL2_I_in	t _{IN} , t _{GCLK_IN} , t _{RSTb} , t _{GOE}	Using SSTL2_I standard	—	1.00	—	1.00	—	1.00	—	1.00	ns
SSTL2_II_in	t _{IN} , t _{GCLK_IN} , t _{RSTb} , t _{GOE}	Using SSTL2_II standard	—	1.00	—	1.00	—	1.00	—	1.00	ns
CTT33_in	t _{IN} , t _{GCLK_IN} , t _{RSTb} , t _{GOE}	Using CTT3.3 standard	—	0.0	—	0.0	—	0.0	—	0.0	ns
CTT25_in	t _{IN} , t _{GCLK_IN} , t _{RSTb} , t _{GOE}	Using CTT2.5 standard	—	0.15	—	0.15	—	0.15	—	0.15	ns
HSTL_I_in	t _{IN} , t _{GCLK_IN} , t _{RSTb} , t _{GOE}	Using HSTL_I standard	—	1.25	—	1.25	—	1.25	—	1.25	ns
HSTL_III_in	t _{IN} , t _{GCLK_IN} , t _{RSTb} , t _{GOE}	Using HSTL_III standard	—	1.25	—	1.25	—	1.25	—	1.25	ns
GTL+_in	t _{IN} , t _{GCLK_IN} , t _{RSTb} , t _{GOE}	Using GTL+ standard	—	1.50	—	1.50	—	1.50	—	1.50	ns
LVDS_in	t _{GCLK_IN}	Using LVDS standard	—	1.70	—	1.70	—	1.70	—	1.70	ns
LVPECL_in	t _{GCLK_IN}	Using LVPECL standard	—	2.10	—	2.10	—	2.10	—	2.10	ns
t_{IOO} Output Adders											
LVC MOS18_4mA_out	t _{BUF} , t _{EN} , t _{DIS}	Output configured as 1.8V & 4mA Buffer	—	3.00	—	3.00	—	3.00	—	3.00	ns
LVC MOS18_5mA_out	t _{BUF} , t _{EN} , t _{DIS}	Output configured as 1.8V & 5.33mA Buffer	—	2.50	—	2.50	—	2.50	—	2.50	ns
LVC MOS18_8mA_out	t _{BUF} , t _{EN} , t _{DIS}	Output configured as 1.8V & 8mA Buffer	—	1.85	—	1.85	—	1.85	—	1.85	ns

Note: Open drain timing is the same as corresponding LVC MOS timing.

Timing v.1.20

ispMACH 5768VG Timing Adders (Continued)

Adder Type	Base Parameter	Description	-5		-75		-10		-12		Units
			Min	Max	Min	Max	Min	Max	Min	Max	
LVC MOS18_12mA_out	t _{BUF} t _{EN} t _{DIS}	Output configured as 1.8V & 12mA Buffer	—	1.35	—	1.35	—	1.35	—	1.35	ns
LVC MOS25_4mA_out	t _{BUF} t _{EN} t _{DIS}	Output configured as 2.5V & 4mA Buffer	—	1.50	—	1.50	—	1.50	—	1.50	ns
LVC MOS25_5mA_out	t _{BUF} t _{EN} t _{DIS}	Output configured as 2.5V & 5.33mA Buffer	—	1.25	—	1.25	—	1.25	—	1.25	ns
LVC MOS25_8mA_out	t _{BUF} t _{EN} t _{DIS}	Output configured as 2.5V & 8mA Buffer	—	0.70	—	0.70	—	0.70	—	0.70	ns
LVC MOS25_12mA_out	t _{BUF} t _{EN} t _{DIS}	Output configured as 2.5V & 12mA Buffer	—	0.50	—	0.50	—	0.50	—	0.50	ns
LVC MOS25_16mA_out	t _{BUF} t _{EN} t _{DIS}	Output configured as 2.5V & 16mA Buffer	—	0.25	—	0.25	—	0.25	—	0.25	ns
LVC MOS33_4mA_out	t _{BUF} t _{EN} t _{DIS}	Output configured as 3.3V & 4mA Buffer	—	1.50	—	1.50	—	1.50	—	1.50	ns
LVC MOS33_5mA_out	t _{BUF} t _{EN} t _{DIS}	Output configured as 3.3V & 5.33mA Buffer	—	1.25	—	1.25	—	1.25	—	1.25	ns
LVC MOS33_8mA_out	t _{BUF} t _{EN} t _{DIS}	Output configured as 3.3V & 8mA Buffer	—	0.40	—	0.40	—	0.40	—	0.40	ns
LVC MOS33_12mA_out	t _{BUF} t _{EN} t _{DIS}	Output configured as 3.3V & 12mA Buffer	—	0.10	—	0.10	—	0.10	—	0.10	ns
LVC MOS33_16mA_out	t _{BUF} t _{EN} t _{DIS}	Output configured as 3.3V & 16mA Buffer	—	0.0	—	0.0	—	0.0	—	0.0	ns
LVC MOS33_20mA_out	t _{BUF} t _{EN} t _{DIS}	Output configured as 3.3V & 20mA Buffer	—	0.0	—	0.0	—	0.0	—	0.0	ns
LV TTL	t _{BUF} t _{EN} t _{DIS}	Output configured as LV TTL Buffer	—	0.0	—	0.0	—	0.0	—	0.0	ns
Slow Slew	t _{BUF} t _{EN}	Output configured for slow slew rate	—	1.50	—	1.50	—	1.50	—	1.50	ns
PCI_out	t _{BUF} t _{EN} t _{DIS}	Using PCI standard	—	0.0	—	0.0	—	0.0	—	0.0	ns
PCI_X_out	t _{BUF} t _{EN} t _{DIS}	Using PCI-X standard	—	0.0	—	0.0	—	0.0	—	0.0	ns
AGP_1X_out	t _{BUF} t _{EN} t _{DIS}	Using AGP-1X standard	—	0.0	—	0.0	—	0.0	—	0.0	ns
SSTL3_I_out	t _{BUF} t _{EN} t _{DIS}	Using SSTL3_I standard	—	-0.25	—	-0.25	—	-0.25	—	-0.25	ns
SSTL3_II_out	t _{BUF} t _{EN} t _{DIS}	Using SSTL3_II standard	—	-0.35	—	-0.35	—	-0.35	—	-0.35	ns
SSTL2_I_out	t _{BUF} t _{EN} t _{DIS}	Using SSTL2_I standard	—	0.0	—	0.0	—	0.0	—	0.0	ns
SSTL2_II_out	t _{BUF} t _{EN} t _{DIS}	Using SSTL2_II standard	—	-0.25	—	-0.25	—	-0.25	—	-0.25	ns
CTT33_out	t _{BUF} t _{EN} t _{DIS}	Using CCT3.3 standard	—	0.0	—	0.0	—	0.0	—	0.0	ns
CTT25_out	t _{BUF} t _{EN} t _{DIS}	Using CCT2.5 standard	—	0.25	—	0.25	—	0.25	—	0.25	ns
HSTL_I_out	t _{BUF} t _{EN} t _{DIS}	Using HSTL_I standard	—	-0.30	—	-0.30	—	-0.30	—	-0.30	ns

Note: Open drain timing is the same as corresponding LVC MOS timing.

Timing v.1.20

ispMACH 5768VG Timing Adders (Continued)

Adder Type	Base Parameter	Description	-5		-75		-10		-12		Units
			Min	Max	Min	Max	Min	Max	Min	Max	
HSTL_III_out	t_{BUF} , t_{EN} , t_{DIS}	Using HSTL_III standard	—	0.00	—	0.00	—	0.00	—	0.00	ns
GTL+_out	t_{BUF} , t_{EN} , t_{DIS}	Using GTL+ standard	—	0.30	—	0.30	—	0.30	—	0.30	ns

Note: Open drain timing is the same as corresponding LVCMOS timing.

Timing v.1.20

ispMACH 51024VG Timing Adders

Adder Type	Base Parameter	Description	-5		-75		-10		-12		Units
			Min	Max	Min	Max	Min	Max	Min	Max	
t_{BLA}	t_{ROUTE}	GLB Loading Adder	—	0.0	—	0.0	—	0.0	—	0.0	ns
t_{EXP}	t_{PTSA}	PT Expander Adder	—	1.5	—	2.0	—	2.5	—	2.5	ns
t_{LP}	t_{ROUTE}	Low Power Adder	—	1.5	—	1.5	—	1.5	—	1.5	ns
t_{IOI} Input Adders											
LVCMOS18_in	t_{IN} , t_{GCLK_IN} , t_{RSTb} , t_{GOE}	Using LVCMOS1.8 standard	—	0.90	—	0.90	—	0.90	—	0.90	ns
LVCMOS25_in	t_{IN} , t_{GCLK_IN} , t_{RSTb} , t_{GOE}	Using LVCMOS2.5 standard	—	0.15	—	0.15	—	0.15	—	0.15	ns
LVCMOS33_in	t_{IN} , t_{GCLK_IN} , t_{RSTb} , t_{GOE}	Using LVCMOS3.3 standard	—	0.0	—	0.0	—	0.0	—	0.0	ns
LVTTTL	t_{IN} , t_{GCLK_IN} , t_{RSTb} , t_{GOE}	Using LVTTTL standard	—	0.0	—	0.0	—	0.0	—	0.0	ns
PCI_in	t_{IN} , t_{GCLK_IN} , t_{RSTb} , t_{GOE}	Using PCI standard	—	0.0	—	0.0	—	0.0	—	0.0	ns
PCI_X_in	t_{IN} , t_{GCLK_IN} , t_{RSTb} , t_{GOE}	Using PCI_X standard	—	0.0	—	0.0	—	0.0	—	0.0	ns
AGP_1X_in	t_{IN} , t_{GCLK_IN} , t_{RSTb} , t_{GOE}	Using AGP-1X standard	—	0.0	—	0.0	—	0.0	—	0.0	ns
SSTL3_I_in	t_{IN} , t_{GCLK_IN} , t_{RSTb} , t_{GOE}	Using SSTL3_I standard	—	1.00	—	1.00	—	1.00	—	1.00	ns
SSTL3_II_in	t_{IN} , t_{GCLK_IN} , t_{RSTb} , t_{GOE}	Using SSTL3_II standard	—	1.00	—	1.00	—	1.00	—	1.00	ns
SSTL2_I_in	t_{IN} , t_{GCLK_IN} , t_{RSTb} , t_{GOE}	Using SSTL2_I standard	—	1.00	—	1.00	—	1.00	—	1.00	ns
SSTL2_II_in	t_{IN} , t_{GCLK_IN} , t_{RSTb} , t_{GOE}	Using SSTL2_II standard	—	1.00	—	1.00	—	1.00	—	1.00	ns
CTT33_in	t_{IN} , t_{GCLK_IN} , t_{RSTb} , t_{GOE}	Using CTT3.3 standard	—	0.0	—	0.0	—	0.0	—	0.0	ns
CTT25_in	t_{IN} , t_{GCLK_IN} , t_{RSTb} , t_{GOE}	Using CTT2.5 standard	—	0.15	—	0.15	—	0.15	—	0.15	ns
HSTL_I_in	t_{IN} , t_{GCLK_IN} , t_{RSTb} , t_{GOE}	Using HSTL_I standard	—	1.25	—	1.25	—	1.25	—	1.25	ns
HSTL_III_in	t_{IN} , t_{GCLK_IN} , t_{RSTb} , t_{GOE}	Using HSTL_III standard	—	1.25	—	1.25	—	1.25	—	1.25	ns
GTL+_in	t_{IN} , t_{GCLK_IN} , t_{RSTb} , t_{GOE}	Using GTL+ standard	—	1.50	—	1.50	—	1.50	—	1.50	ns

Note: Open drain timing is the same as corresponding LVCMOS timing.

Timing v.1.10

ispMACH 51024VG Timing Adders (Continued)

Adder Type	Base Parameter	Description	-5		-75		-10		-12		Units
			Min	Max	Min	Max	Min	Max	Min	Max	
LVDS_in	t _{GCLK_IN}	Using LVDS standard	—	1.70	—	1.70	—	1.70	—	1.70	ns
LVPECL_in	t _{GCLK_IN}	Using LVPECL standard	—	2.10	—	2.10	—	2.10	—	2.10	ns
t₁₀₀ Output Adders											
LVC MOS18_4mA_out	t _{BUF} t _{EN} t _{DIS}	Output configured as 1.8V & 4mA Buffer	—	3.00	—	3.00	—	3.00	—	3.00	ns
LVC MOS18_5mA_out	t _{BUF} t _{EN} t _{DIS}	Output configured as 1.8V & 5.33mA Buffer	—	2.50	—	2.50	—	2.50	—	2.50	ns
LVC MOS18_8mA_out	t _{BUF} t _{EN} t _{DIS}	Output configured as 1.8V & 8mA Buffer	—	1.85	—	1.85	—	1.85	—	1.85	ns
LVC MOS18_12mA_out	t _{BUF} t _{EN} t _{DIS}	Output configured as 1.8V & 12mA Buffer	—	1.35	—	1.35	—	1.35	—	1.35	ns
LVC MOS25_4mA_out	t _{BUF} t _{EN} t _{DIS}	Output configured as 2.5V & 4mA Buffer	—	1.50	—	1.50	—	1.50	—	1.50	ns
LVC MOS25_5mA_out	t _{BUF} t _{EN} t _{DIS}	Output configured as 2.5V & 5.33mA Buffer	—	1.25	—	1.25	—	1.25	—	1.25	ns
LVC MOS25_8mA_out	t _{BUF} t _{EN} t _{DIS}	Output configured as 2.5V & 8mA Buffer	—	0.70	—	0.70	—	0.70	—	0.70	ns
LVC MOS25_12mA_out	t _{BUF} t _{EN} t _{DIS}	Output configured as 2.5V & 12mA Buffer	—	0.50	—	0.50	—	0.50	—	0.50	ns
LVC MOS25_16mA_out	t _{BUF} t _{EN} t _{DIS}	Output configured as 2.5V & 16mA Buffer	—	0.25	—	0.25	—	0.25	—	0.25	ns
LVC MOS33_4mA_out	t _{BUF} t _{EN} t _{DIS}	Output configured as 3.3V & 4mA Buffer	—	1.50	—	1.50	—	1.50	—	1.50	ns
LVC MOS33_5mA_out	t _{BUF} t _{EN} t _{DIS}	Output configured as 3.3V & 5.33mA Buffer	—	1.25	—	1.25	—	1.25	—	1.25	ns
LVC MOS33_8mA_out	t _{BUF} t _{EN} t _{DIS}	Output configured as 3.3V & 8mA Buffer	—	0.40	—	0.40	—	0.40	—	0.40	ns
LVC MOS33_12mA_out	t _{BUF} t _{EN} t _{DIS}	Output configured as 3.3V & 12mA Buffer	—	0.10	—	0.10	—	0.10	—	0.10	ns
LVC MOS33_16mA_out	t _{BUF} t _{EN} t _{DIS}	Output configured as 3.3V & 16mA Buffer	—	0.0	—	0.0	—	0.0	—	0.0	ns
LVC MOS33_20mA_out	t _{BUF} t _{EN} t _{DIS}	Output configured as 3.3V & 20mA Buffer	—	0.0	—	0.0	—	0.0	—	0.0	ns
LVTTTL	t _{BUF} t _{EN} t _{DIS}	Output configured as LVTTTL Buffer	—	0.0	—	0.0	—	0.0	—	0.0	ns
Slow Slew	t _{BUF} t _{EN}	Output configured for slow slew rate	—	1.50	—	1.50	—	1.50	—	1.50	ns
PCI_out	t _{BUF} t _{EN} t _{DIS}	Using PCI standard	—	0.0	—	0.0	—	0.0	—	0.0	ns
PCI_X_out	t _{BUF} t _{EN} t _{DIS}	Using PCI-X standard	—	0.0	—	0.0	—	0.0	—	0.0	ns
AGP_1X_out	t _{BUF} t _{EN} t _{DIS}	Using AGP-1X standard	—	0.0	—	0.0	—	0.0	—	0.0	ns
SSTL3_I_out	t _{BUF} t _{EN} t _{DIS}	Using SSTL3_I standard	—	-0.25	—	-0.25	—	-0.25	—	-0.25	ns
SSTL3_II_out	t _{BUF} t _{EN} t _{DIS}	Using SSTL3_II standard	—	-0.35	—	-0.35	—	-0.35	—	-0.35	ns

Note: Open drain timing is the same as corresponding LVC MOS timing.

Timing v.1.10

ispMACH 51024VG Timing Adders (Continued)

Adder Type	Base Parameter	Description	-5		-75		-10		-12		Units
			Min	Max	Min	Max	Min	Max	Min	Max	
SSTL2_I_out	t_{BUF} , t_{EN} , t_{DIS}	Using SSTL2_I standard	—	0.0	—	0.0	—	0.0	—	0.0	ns
SSTL2_II_out	t_{BUF} , t_{EN} , t_{DIS}	Using SSTL2_II standard	—	-0.25	—	-0.25	—	-0.25	—	-0.25	ns
CTT33_out	t_{BUF} , t_{EN} , t_{DIS}	Using CCT3.3 standard	—	0.0	—	0.0	—	0.0	—	0.0	ns
CTT25_out	t_{BUF} , t_{EN} , t_{DIS}	Using CCT2.5 standard	—	0.25	—	0.25	—	0.25	—	0.25	ns
HSTL_I_out	t_{BUF} , t_{EN} , t_{DIS}	Using HSTL_I standard	—	-0.30	—	-0.30	—	-0.30	—	-0.30	ns
HSTL_III_out	t_{BUF} , t_{EN} , t_{DIS}	Using HSTL_III standard	—	0.00	—	0.00	—	0.00	—	0.00	ns
GTL+_out	t_{BUF} , t_{EN} , t_{DIS}	Using GTL+ standard	—	0.30	—	0.30	—	0.30	—	0.30	ns

Note: Open drain timing is the same as corresponding LVCMOS timing.

Timing v.1.10

sysCLOCK PLL Timing

Over Recommended Operating Conditions¹

Symbol	Parameter	Conditions	Min	Max	Units
$t_{R,tF}$	Input clock, rise and fall time	20% to 80%	—	3.0	ns
t_{INSTB}	Input clock stability, period jitter (peak) ¹	—	—	+/- 200	ps
t_{PWH}	Input clock, high time	—	1.6	—	ns
t_{PWL}	Input clock, low time	—	1.6	—	ns
f_{MDIVIN}	M Divider input, frequency range	—	5	180	MHz
$f_{MDIVOUT}$	M Divider output, frequency range	—	5	180	MHz
f_{VDIVIN}	V Divider input, frequency range	—	60	200	MHz
$f_{VDIVOUT}$	V Divider output, frequency range	—	5	180	MHz
$t_{OUTDUTY}$	Output clock, duty cycle	—	40	60	%
$t_{JIT(CC)}$	Output clock, cycle to cycle jitter (peak)	Clean Reference, $5\text{MHz} \leq f_{MDIVOUT} < 80\text{MHz}$	—	+/- 200	ps
		Clean Reference, $80\text{MHz} \leq f_{MDIVOUT} \leq 180\text{MHz}$	—	+/- 100	ps
$t_{JIT(\phi)}$	Output clock, accumulated phase jitter (peak) ²	Clean Reference, $5\text{MHz} \leq f_{MDIVOUT} < 80\text{MHz}$	—	+/- 200	ps
		Clean Reference, $80\text{MHz} \leq f_{MDIVOUT} \leq 180\text{MHz}$	—	+/- 100	ps
$t_{CLK_OUT_DLY}$	Input clock to CLK_OUT delay	Internal feedback	—	1	ns
t_{ϕ}	Input clock to external feedback delta	External feedback	—	500	ps
t_{LOCK}	Time to acquire phase lock after input stable	—	—	30	μs
t_{PLL_DELAY}	Delay increment	—	+/- 0.35	+/- 0.65	ns
t_{RANGE}	Total output delay range	—	+/- 2.45	+/- 4.55	ns
t_{PLL_RSTR}	Reset recovery time of the M-divider	—	11.0	—	ns
t_{PLL_RSTW}	Minimum reset pulse width	—	6.0	—	ns

1. This condition assures that the output phase jitter ($t_{JIT(\phi)}$) will remain within specification.

2. Accumulated jitter measured over 10,000 waveform samples.

Boundary Scan Timing Specifications

Symbol	Parameter	Min.	Max.	Units
t_{BTCP}	TCK [BSCAN test] clock cycle	40	—	ns
t_{BTCH}	TCK [BSCAN test] pulse width high	20	—	ns
t_{BTCL}	TCK [BSCAN test] pulse width low	20	—	ns
t_{BTSU}	TCK [BSCAN test] setup time	8	—	ns
t_{BTH}	TCK [BSCAN test] hold time	10	—	ns
t_{BRF}	TCK [BSCAN test] rise and fall time	50	—	mV/ns
t_{BTOZ}	TAP controller falling edge of clock to data output disable	—	10	ns
t_{BTVO}	TAP controller falling edge of clock to data output enable	—	10	ns
$t_{BVTCPUSU}$	BSCAN test Capture register setup time	8	—	ns
t_{BTCPH}	BSCAN test Capture register hold time	10	—	ns
t_{BTUCO}	BSCAN test Update reg, falling edge of clock to valid output	—	25	ns
t_{BTUOZ}	BSCAN test Update reg, falling edge of clock to output disable	—	25	ns
t_{BTUOV}	BSCAN test Update reg, falling edge of clock to output enable	—	25	ns

Power Consumption

ispMACH 5000VG Typical Power vs. Frequency

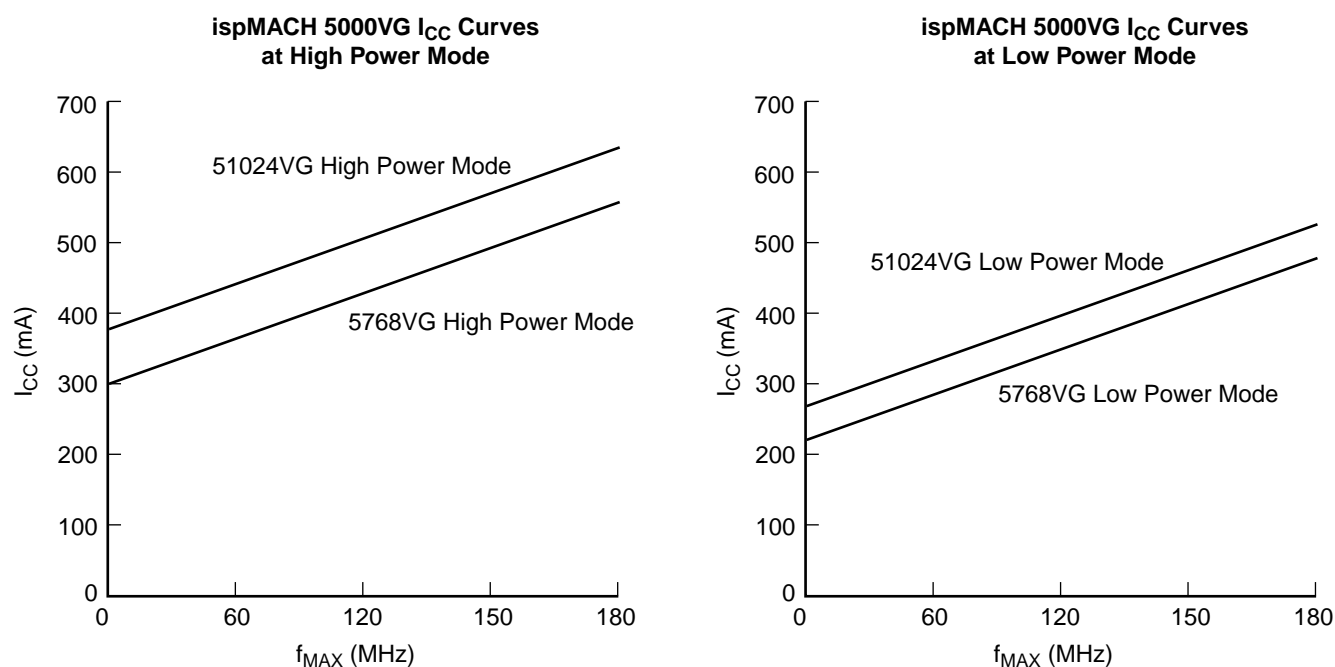

Note: The devices are configured with maximum number of 16-bit counters, no PLL, typical current at 3.3V, 25° C.

Power Estimation Coefficients

Device	K0	K1	K2	K3	K4	K5	K6	I_{DC} (mA)	I_{DCO} (mA)
ispMACH 5768VG	0.0014	0.0014	0.054	1.5	0.152	0.105	5.0	65	20
ispMACH 51024VG	0.0014	0.0014	0.054	1.5	0.152	0.105	5.0	80	20

Note: For further information about the use of these coefficients, refer to Technical Note TN1002, *Power Estimation in ispMACH 5000VG Devices*.

K0 = average current per product term in high power/MHz

K1 = average current per product term in low power/MHz

K2 = average current per GRP line/MHz

K3 = average current per PLL/MHz

K4 = DC current per product terms in high power

K5 = DC current per product terms in low power

K6 = Static DC current per PLL

I_{DC} = Static device current with all product terms powered off

I_{DCO} = Static I/O bank current

I_{CC} estimates are based on typical conditions ($V_{CC} = 3.3V$, room temperature) and an assumption of one GLB load on average exists. These values are for estimates only. Since the value of I_{CC} is sensitive to operating conditions and the program in the device, the actual I_{CC} should be verified.

Switching Test Conditions

Figure 12 shows the output test load that is used for AC testing. The specific values for resistance, capacitance, voltage, and other test conditions are shown in Table 3.

Figure 12. Output Test Load, LVTTTL and LVCMOS Standards

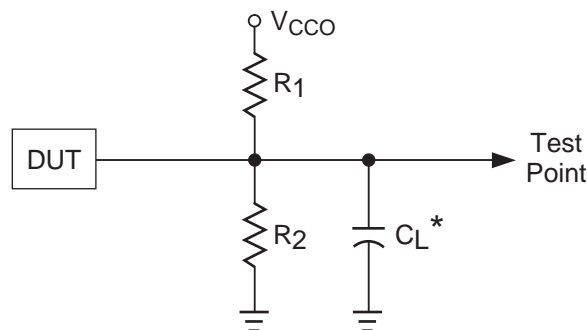

* C_L includes Test Fixture and Probe Capacitance.

0213A/ispm5kvg

Table 3. Test Fixture Required Components

Test Condition	R_1	R_2	C_L	Timing Ref.	V_{CCO}
Default LVCMOS 3.3 I/O (L -> H, H -> L)	110	110	35pF	1.5	3.0V
Other LVCMOS Settings, (L -> H, H -> L)	∞	∞	35pF	LVCMOS 3.3 = 1.5V	LVCMOS 3.3 = 3.0V
				LVCMOS 2.5 = $V_{CCO}/2$	LVCMOS 2.5 = 2.3V
				LVCMOS 1.8 = $V_{CCO}/2$	LVCMOS 1.8 = 1.65V
Default LVCMOS 3.3 I/O (Z -> H)	∞	110	35pF	1.5V	3.0V
Default LVCMOS 3.3 I/O (Z -> L)	110	∞	35pF	1.5V	3.0V
Default LVCMOS 3.3 I/O (H -> Z)	∞	110	5pF	$V_{OH} - 0.3$	3.0V
Default LVCMOS 3.3 I/O (L -> Z)	110	∞	5pF	$V_{OL} + 0.3$	3.0V

Output test conditions for all other interfaces are determined by the respective standards. For further details, please refer to the following technical note:

- *ispMACH 5000VG sysIO Design and Usage Guidelines (TN1000)*

Signal Descriptions

Signal Names	Description
TMS	Input - This pin is the Test Mode Select input, which is used to control the 1149.1 state machine.
TCK	Input - This pin is the Test Clock input pin, used to clock the 1149.1 state machine.
TDI	Input - This pin is the 1149.1 Test Data In pin, used to load data.
TDO	Output - This pin is the 1149.1 Test Data Out pin used to shift data out.
TOE	Input - Test Output Enable pin. TOE tristates all I/O pins when a logic low is driven.
GOE0, GOE1	Input - These two pins are the Global Output Enable input pins.
RESETB	Dedicated Reset Input - This pin resets all registers in the devices. The global polarity (active high or low input) for this pin is selectable.
xyzz (e.g. 0A16)	Input/Output - These are the general purpose I/O used by the logic array. x is segment reference (numeric), y is GLB reference (alpha) and z is macrocell reference (numeric). x: 0-7 (1024) x: 0-5 (768) y: A-D z: 0-31
GND	Ground
NC	No connect
V _{CC}	V _{CC} - These are the power supply pins for the logic core.
GCLK0, GCLK3	Input - These pins are configured to be either dedicated CLK input or PLL input.
GCLK1, GCLK2	Input - These pins are dedicated CLK input.
CLK_OUT0, CLK_OUT1	Output - These pins are the PLL output pins.
PLL_RST0, PLL_RST1	Input - These pins are for resetting the PLL, input clock (M) divider.
VREF0, VREF1, VREF2, VREF3	Input - These are the reference supplies for the I/O banks.
PLL_FBK0, PLL_FBK1	Input - These PLL feedback inputs allow optional external PLL feedback.
V _{CCP0} , V _{CCP1}	V _{CC} - These are the V _{CC} supplies for the PLLs.
V _{CCO0} , V _{CCO1} , V _{CCO2} , V _{CCO3}	V _{CC} - These are the V _{CC} supplies for each I/O bank.
GNDP0, GNDP1	GND - These are the separate ground connections for the PLLs.
V _{CCJ}	V _{CC} - This pin is for the 1149.1 test access port.

Note: For above, signal CLK_OUT0 connects to PLL0, and signal CLK_OUT1 connects to PLL1.

ispMACH 5768VG Power Supply and NC Connections¹

Signal	256-Ball fpBGA ²	484-Ball fpBGA ²
V _{CC}	F8, F9, H6, H11, J6, J11, L8, L9	B17, B2, B21, B6, C14, C9, E18, E5, F2, F21, J20, J3, P20, P3, U2, U21, Y14, Y9, AA17, AA2, AA21, AA6
V _{CCO0}	C3, C7, G3	B5, D7, E2, E6, E9, F5, G4, J5
V _{CCO1}	K3, P3, P7	P5, U5, V6, V9, Y3
V _{CCO2}	K14, P10, P14	P18, U18, V14, V17, Y20
V _{CCO3}	C10, C14, G14	B18, D16, E14, E17, E21, F18, G19, J18
V _{CCP0}	H1	L7
V _{CCP1}	H16	N18
V _{CCJ}	J1	P4
V _{REF0}	E7	A9
V _{REF1}	M7	AA10
V _{REF2}	R13	AA13
V _{REF3}	A8	A15
GND PLL 0	H7	L6
GND PLL 1	J10	L16
GND	A1, C5, C12, E3, E14, G7, G8, G9, G10, H8, H9, H10, J7, J8, J9, K7, K8, K9, K10, M3, M14, P5, P12	A1, A22, C3, C20, D4, D19, E7, E16, G5, G7, G8, G9, G10, G11, G12, G13, G14, G15, G16, G18, H7, H8, H9, H10, H11, H12, H13, H14, H15, H16, J7, J8, J9, J10, J11, J12, J13, J14, J15, J16, K7, K8, K9, K10, K11, K12, K13, K14, K15, K16, L8, L9, L10, L11, L12, L13, L14, L15, M7, M8, M9, M10, M11, M12, M13, M14, M15, M16, N7, N8, N9, N10, N11, N12, N13, N14, N15, N16, P7, P8, P9, P10, P11, P12, P13, P14, P15, P16, R7, R8, R9, R10, R11, R12, R13, R14, R15, R16, T4, T7, T8, T9, T10, T11, T12, T13, T14, T15, T16, T19, W7, W16, AB1, AB22
NC ³	—	AA1

1. All grounds must be electrically connected at the board level.
2. Not all grounds internally connected within the device.
3. NC pins are not to be connected to any active signals, VCC or GND.

ispMACH 51024 Power Supply and NC Connections¹

Signal	484-Ball fpBGA ²	676-Ball fpBGA ²
V _{CC}	B17, B2, B21, B6, C14, C9, E18, E5, F2, F21, J20, J3, P20, P3, U2, U21, Y14, Y9, AA17, AA2, AA21, AA6	B29, D6, D10, D12, D19, D21, D25, F4, F27, K4, K27, M4, M27, W4, W27, AA4, AA27, AE4, AE27, AG6, AG10, AG12, AG19, AG21, AG25, AJ2
V _{CCO0}	B5, D7, E2, E6, E9, F5, G4, J5	E5, E7, E9, E11, F10, G5, J5, K6, L5
V _{CCO1}	P5, U5, V6, V9, Y3	Y5, AA6, AB5, AD5, AE10, AF5, AF7, AF9, AF11
V _{CCO2}	P18, U18, V14, V17, Y20	Y26, AA25, AB26, AD26, AE21, AF20, AF22, AF24, AF26
V _{CCO3}	B18, D16, E14, E17, E21, F18, G19, J18	E20, E22, E24, E26, F21, G26, J26, K25, L26
V _{CCP0}	L7	P5
V _{CCP1}	N18	N26
V _{CCJ}	P4	U6
V _{REF0}	A9	C11
V _{REF1}	AA10	AK10
V _{REF2}	AA13	AJ21
V _{REF3}	A15	E19
GND PLL 0	L6	R6
GND PLL 1	L16	P25
GND	A1, A22, C3, C20, D4, D19, E7, E16, G5, G7, G8, G9, G10, G11, G12, G13, G14, G15, G16, G18, H7, H8, H9, H10, H11, H12, H13, H14, H15, H16, J7, J8, J9, J10, J11, J12, J13, J14, J15, J16, K7, K8, K9, K10, K11, K12, K13, K14, K15, K16, L8, L9, L10, L11, L12, L13, L14, L15, M7, M8, M9, M10, M11, M12, M13, M14, M15, M16, N7, N8, N9, N10, N11, N12, N13, N14, N15, N16, P7, P8, P9, P10, P11, P12, P13, P14, P15, P16, R7, R8, R9, R10, R11, R12, R13, R14, R15, R16, T4, T7, T8, T9, T10, T11, T12, T13, T14, T15, T16, T19, W7, W16, AB1, AB22	A1, A30, B2, C3, C28, D8, D23, F7, F9, F11, F12, F19, F20, F22, F24, G6, G25, H4, H27, J6, J25, L6, L11, L12, L13, L14, L15, L16, L17, L18, L19, L20, L25, M6, M11, M12, M13, M14, M15, M16, M17, M18, M19, M20, M25, N11, N12, N13, N14, N15, N16, N17, N18, N19, N20, P11, P12, P13, P14, P15, P16, P17, P18, P19, P20, R11, R12, R13, R14, R15, R16, R17, R18, R19, R20, T11, T12, T13, T14, T15, T16, T17, T18, T19, T20, U11, U12, U13, U14, U15, U16, U17, U18, U19, U20, V11, V12, V13, V14, V15, V16, V17, V18, V19, V20, W6, W11, W12, W13, W14, W15, W16, W17, W18, W19, W20, W25, Y6, Y11, Y12, Y13, Y14, Y15, Y16, Y17, Y18, Y19, Y20, Y25, AB6, AB25, AC4, AC27, AD6, AD25, AE7, AE9, AE11, AE12, AE19, AE20, AE22, AE24, AG8, AG23, AH3, AH28, AK1, AK30
NC ³	AA1	A14, A15, A16, A17, B14, B15, B16, B17, C13, C14, C15, C16, C17, C18, D13, D14, D15, D16, D17, D18, E13, E14, E15, E16, E17, E18, F13, F14, F15, F16, F17, F18, AE13, AE14, AE15, AE16, AE17, AE18, AF13, AF14, AF15, AF16, AF17, AF18, AG13, AG14, AG15, AG16, AG17, AG18, AH14, AH15, AH16, AH17, AH18, AJ14, AJ15, AJ16, AJ17, AJ18, AK14, AK15, AK16, AK17

1. All grounds must be electrically connected at the board level.
2. Not all grounds internally connected within the device.
3. NC pins are not to be connected to any active signals, VCC or GND.

ispMACH 5768VG Logic Signal Connections

Bank No.	Signal	256 fpBGA	484 fpBGA
0	0C-30	C8	D11
0	0C-28	B6	B11
0	0C-26	A5	E12
0	0C-24	D8	C11
0	0C-22	E8	F12
0	0C-20	B5	B10
0	GNDIO0	GND	GND
0	0C-18	A4	A10
0	0C-16	D7	D10
0	0C-14/VREF0	E7	A9
0	0C-12	C6	E11
0	0C-10	B4	B9
0	0C-8	A3	F11
0	0C-6	NC	A8
0	0C-4	NC	C10
0	0C-2	NC	A7
0	0C-0	NC	E10
0	0D-30	NC	B8
0	0D-28	NC	C8
0	GNDIO0	GND	GND
0	0D-26	NC	F10
0	0D-24	NC	A6
0	0D-22	NC	F9
0	0D-20	NC	C7
0	0D-18	NC	D9
0	0D-16	NC	B7
0	0D-14	D6	E8
0	0D-12	E6	A5
0	0D-10	A2	F8
0	0D-8	B3	C6
0	0D-6	C4	D8
0	0D-4	D5	A3
0	GNDIO0	GND	GND
0	0D-2	NC	A2
0	0D-0	NC	A4
0	0A-0	NC	F7
0	0A-2	NC	C5
0	0A-4	NC	F6
0	0A-6	NC	B3
0	0A-8	NC	NC
0	0A-10	NC	NC
0	GNDIO0	GND	GND
0	0A-12	NC	NC

Bank No.	Signal	256 fpBGA	484 fpBGA
0	0A-14	NC	NC
0	0A-16	NC	B4
0	0A-18	NC	D5
0	0A-20	NC	B1
0	0A-22	NC	D6
0	0A-24	NC	C4
0	0A-26	NC	E4
0	GNDIO0	GND	GND
0	0A-28	B2	C2
0	0A-30	B1	C1
0	0B-30	C2	D1
0	0B-28	C1	D2
0	0B-26	NC	D3
0	0B-24	NC	E1
0	0B-22	NC	E3
0	0B-20	NC	F4
0	0B-18	NC	F1
0	0B-16	NC	F3
0	0B-14	NC	G6
0	0B-12	NC	G1
0	GNDIO0	GND	GND
0	0B-10	NC	G2
0	0B-8	NC	H1
0	0B-6	NC	G3
0	0B-4	NC	H2
0	0B-2	NC	H5
0	0B-0	NC	H6
0	1A-0	F7	J1
0	1A-2	F6	K1
0	1A-4	E5	H3
0	1A-6	D4	J2
0	1A-8	D3	H4
0	1A-10	D2	K2
0	GNDIO0	GND	GND
0	1A-12	D1	J6
0	1A-14	E4	L1
0	1A-16	NC	K3
0	1A-18	NC	J4
0	1A-20	NC	L2
0	1A-22	NC	M1
0	1A-24	NC	K6
0	1A-26	NC	K4
0	1A-28	NC	L3

ispMACH 5768VG Logic Signal Connections (Continued)

Bank No.	Signal	256 fpBGA	484 fpBGA	Bank No.	Signal	256 fpBGA	484 fpBGA
0	1A-30	NC	K5	1	2A-18	NC	U6
0	GNDIO0	GND	GND	1	2A-16	R1	AA4
0	1B-30/CLK_OUT0	G6	N1	1	2A-14	NC	NC
0	1B-28	NC	M2	1	2A-12	NC	NC
0	1B-26	NC	P1	1	GNDIO1	GND	GND
0	1B-24	NC	L4	1	2A-10	NC	NC
0	1B-22	F5	N2	1	2A-8	NC	NC
0	1B-20	E2	M3	1	2A-6	T1	W6
0	1B-18	E1	L5	1	2A-4	T2	V4
0	1B-16	F4	R1	1	2A-2	R2	U7
0	1B-14	F3	P2	1	2A-0	T3	AB2
0	1B-12	F2	N3	1	2D-0	R3	V7
0	GNDIO0	GND	GND	1	2D-2	P4	AA5
0	1B-10	G5	M6	1	GNDIO1	GND	GND
0	1B-8	G4	M5	1	2D-4	T4	AB3
0	1B-6/PLL_RST0	F1	M4	1	2D-6	N4	Y6
0	1B-4/PLL_FBK0	G2	N4	1	2D-8	M4	AB4
0	1B-2	G1	N6	1	2D-10	N5	Y7
0	1B-0	H5	N5	1	2D-12	R5	AB5
1	2B-0	K1	R5	1	2D-14	T5	V8
1	2B-2	K2	T2	1	2D-16	NC	AA7
1	2B-4	L1	T5	1	2D-18	NC	Y8
1	2B-6	J5	T3	1	2D-20	NC	AB6
1	2B-8	L2	U1	1	2D-22	T6	W8
1	2B-10	K4	U4	1	2D-24	R6	AA8
1	GNDIO1	GND	GND	1	2D-26	P6	Y10
1	2B-12	M1	V1	1	GNDIO1	GND	GND
1	2B-14	L3	U3	1	2D-28	M5	U8
1	2B-16	L4	V5	1	2D-30	T7	AB7
1	2B-18	K5	V2	1	2C-0	T8	U9
1	2B-20	M2	W1	1	2C-2	R8	AA9
1	2B-22	N1	V3	1	2C-4	M6	W9
1	2B-24	NC	W2	1	2C-6	N6	AB8
1	2B-26	K6	Y1	1	2C-8	R7	U10
1	2B-28	L5	Y2	1	2C-10	T9	AB9
1	2B-30	N2	W3	1	2C-12	T10	V11
1	2A-30	L6	AA3	1	2C-14/VREF1	M7	AA10
1	2A-28	L7	W4	1	2C-16	N7	V10
1	GNDIO1	GND	GND	1	2C-18	P8	AB10
1	2A-26	P1	W5	1	GNDIO1	GND	GND
1	2A-24	P2	Y4	1	2C-20	R9	W10
1	2A-22	N3	T6	1	2C-22	N8	W11
1	2A-20	R4	Y5	1	2C-24	M8	U11

ispMACH 5768VG Logic Signal Connections (Continued)

Bank No.	Signal	256 fpBGA	484 fpBGA
1	2C-26	T11	AA11
1	2C-28	T12	V12
1	2C-30	R10	AB11
2	3C-30	P9	W12
2	3C-28	R11	Y11
2	3C-26	T13	Y12
2	3C-24	N9	AB12
2	3C-22	M9	U12
2	3C-20	R12	AA12
2	GNDIO2	GND	GND
2	3C-18	P11	Y13
2	3C-16	N10	AB13
2	3C-14	M10	W13
2	3C-12/VREF2	R13	AA13
2	3C-10	T14	U13
2	3C-8	R14	AB14
2	3C-6	M11	V13
2	3C-4	N11	AA14
2	3C-2	P13	U14
2	3C-0	T15	AB15
2	3D-30	T16	Y15
2	3D-28	N12	AB16
2	GNDIO2	GND	GND
2	3D-26	NC	AA15
2	3D-24	NC	W14
2	3D-22	NC	AB17
2	3D-20	NC	Y16
2	3D-18	NC	AA16
2	3D-16	NC	Y17
2	3D-14	NC	AB18
2	3D-12	NC	V15
2	3D-10	NC	AB19
2	3D-8	NC	W15
2	3D-6	NC	AB20
2	3D-4	NC	AA18
2	GNDIO2	GND	GND
2	3D-2	L10	U15
2	3D-0	L11	W17
2	3A-0	K11	U16
2	3A-2	R15	AA19
2	3A-4	NC	V16
2	3A-6	NC	AB21
2	3A-8	NC	NC

Bank No.	Signal	256 fpBGA	484 fpBGA
2	3A-10	NC	NC
2	GNDIO2	GND	GND
2	3A-12	NC	NC
2	3A-14	NC	NC
2	3A-16	NC	Y18
2	3A-18	P15	W18
2	3A-20	R16	AA20
2	3A-22	P16	W19
2	3A-24	N14	Y19
2	3A-26	N13	V19
2	GNDIO2	GND	GND
2	3A-28	N15	Y21
2	3A-30	N16	W20
2	3B-30	M16	AA22
2	3B-28	M12	W21
2	3B-26	NC	Y22
2	3B-24	NC	V20
2	3B-22	M13	V21
2	3B-20	M15	W22
2	3B-18	L16	V18
2	3B-16	L15	U20
2	3B-14	L13	V22
2	3B-12	L14	U19
2	GNDIO2	GND	GND
2	3B-10	L12	U17
2	3B-8	K13	U22
2	3B-6	K15	T20
2	3B-4	K16	T21
2	3B-2	J16	T17
2	3B-0	K12	R20
3	4B-0	J12	R21
3	4B-2	G16	T22
3	4B-4/PLL_FBK1	G15	P21
3	4B-6/PLL_RST1	H12	N20
3	4B-8	G12	R22
3	4B-10	G13	N21
3	GNDIO3	GND	GND
3	4B-12	F16	M18
3	4B-14	F15	N19
3	4B-16	F13	P22
3	4B-18	F14	M20
3	4B-20	F12	N22
3	4B-22	E16	N17

ispMACH 5768VG Logic Signal Connections (Continued)

Bank No.	Signal	256 fpBGA	484 fpBGA	Bank No.	Signal	256 fpBGA	484 fpBGA
3	4B-24	G11	M19	3	5A-24	C15	C22
3	4B-26	F11	M21	3	5A-22	D14	C18
3	4B-28	F10	L19	3	5A-20	A14	C19
3	4B-30/CLK_OUT1	B11	L20	3	5A-18	C13	D17
3	GNDIO3	GND	GND	3	5A-16	B13	C21
3	4A-30	NC	M17	3	5A-14	NC	NC
3	4A-28	NC	M22	3	5A-12	NC	NC
3	4A-26	NC	K20	3	GNDIO3	GND	GND
3	4A-24	NC	L18	3	5A-10	NC	NC
3	4A-22	NC	L21	3	5A-8	NC	NC
3	4A-20	NC	K19	3	5A-6	NC	B22
3	4A-18	NC	L22	3	5A-4	NC	D18
3	4A-16	NC	K17	3	5A-2	NC	B20
3	4A-14	E13	K22	3	5A-0	NC	F17
3	4A-12	B12	L17	3	5D-0	NC	B19
3	GNDIO3	GND	GND	3	5D-2	NC	C17
3	4A-10	E15	K21	3	GNDIO3	GND	GND
3	4A-8	D15	K18	3	5D-4	NC	A21
3	4A-6	NC	J17	3	5D-6	NC	D15
3	4A-4	NC	J19	3	5D-8	NC	A20
3	4A-2	D16	J22	3	5D-10	NC	C16
3	4A-0	E12	J21	3	5D-12	NC	A19
3	5B-0	NC	H19	3	5D-14	NC	F16
3	5B-2	NC	H20	3	5D-16	NC	B16
3	5B-4	NC	H17	3	5D-18	NC	D14
3	5B-6	NC	H18	3	5D-20	NC	A18
3	5B-8	NC	H22	3	5D-22	A13	F15
3	5B-10	NC	H21	3	5D-24	A12	A17
3	GNDIO3	GND	GND	3	5D-26	A11	B15
3	5B-12	NC	G20	3	GNDIO3	GND	GND
3	5B-14	NC	G22	3	5D-28	A10	A16
3	5B-16	NC	G17	3	5D-30	C11	F14
3	5B-18	NC	G21	3	5C-0	A9	C15
3	5B-20	NC	F19	3	5C-2	D12	D13
3	5B-22	NC	F20	3	5C-4	D11	E15
3	5B-24	A16	F22	3	5C-6	B10	F13
3	5B-26	B15	E22	3	5C-8	B9	B14
3	5B-28	A15	E19	3	5C-10	E11	E13
3	5B-30	D13	E20	3	5C-12/VREF3	A8	A15
3	5A-30	B14	D22	3	5C-14	D10	D12
3	5A-28	B16	D21	3	5C-16	E10	A14
3	GNDIO3	GND	GND	3	5C-18	A7	B13
3	5A-26	C16	D20	3	GNDIO3	GND	GND

ispMACH 5768VG Logic Signal Connections (Continued)

Bank No.	Signal	256 fpBGA	484 fpBGA
3	5C-20	C9	A13
3	5C-22	E9	B12
3	5C-24	D9	C13
3	5C-26	B8	A12
3	5C-28	A6	C12
3	5C-30	B7	A11
—	GCLK0	H4	P6
—	GCLK1	J4	R6
—	GCLK2	H14	P17
—	GCLK3	H13	P19
—	GOE0	J15	R18
—	GOE1	H15	R17
—	RESETB	J14	R19
—	TCK	J3	R3
—	TDI	H3	R2
—	TDO	J2	R4
—	TMS	H2	T1
—	TOE	J13	T18

ispMACH 51024VG Logic Signal Connections

Bank No.	Signal	484 fpBGA	676 fpBGA
0	0C-30	D11	A13
0	0C-28	B11	B13
0	0C-26	E12	A12
0	0C-24	C11	B12
0	0C-22	F12	C12
0	0C-20	B10	A11
0	GNDIO0	GND	GND
0	0C-18	A10	B11
0	0C-16	D10	A10
0	0C-14/VREF0	A9	C11
0	0C-12	E11	E12
0	0C-10	B9	B10
0	0C-8	F11	D11
0	0C-6	A8	A9
0	0C-4	C10	C10
0	0C-2	A7	B9
0	0C-0	E10	A8
0	0D-30	B8	C9
0	0D-28	C8	B8
0	GNDIO0	GND	GND
0	0D-26	F10	E10
0	0D-24	A6	A7
0	0D-22	F9	D9
0	0D-20	C7	C8
0	0D-18	D9	B7
0	0D-16	B7	A6
0	0D-14	E8	C7
0	0D-12	A5	B6
0	0D-10	F8	A5
0	0D-8	C6	C6
0	0D-6	D8	D7
0	0D-4	A3	E8
0	GNDIO0	GND	GND
0	0D-2	A2	B5
0	0D-0	A4	A4
0	0A-0	F7	A3
0	0A-2	C5	B4
0	0A-4	F6	C5
0	0A-6	B3	F8
0	0A-8	NC	A2
0	0A-10	NC	B3
0	GNDIO0	GND	GND
0	0A-12	NC	C4

Bank No.	Signal	484 fpBGA	676 fpBGA
0	0A-14	NC	D5
0	0A-16	B4	E6
0	0A-18	D5	D4
0	0A-20	B1	B1
0	0A-22	D6	C2
0	0A-24	C4	F6
0	0A-26	E4	D3
0	GNDIO0	GND	GND
0	0A-28	C2	E4
0	0A-30	C1	F5
0	0B-30	D1	C1
0	0B-28	D2	D2
0	0B-26	D3	E3
0	0B-24	E1	D1
0	0B-22	E3	E2
0	0B-20	F4	H6
0	0B-18	F1	F3
0	0B-16	F3	E1
0	0B-14	G6	G4
0	0B-12	G1	F2
0	GNDIO0	GND	GND
0	0B-10	G2	H5
0	0B-8	H1	G3
0	0B-6	G3	F1
0	0B-4	H2	G2
0	0B-2	H5	H3
0	0B-0	H6	G1
0	1A-0	J1	H2
0	1A-2	K1	J4
0	1A-4	H3	H1
0	1A-6	J2	J3
0	1A-8	H4	K5
0	1A-10	K2	J2
0	GNDIO0	GND	GND
0	1A-12	J6	J1
0	1A-14	L1	K3
0	1A-16	K3	K2
0	1A-18	J4	K1
0	1A-20	L2	L4
0	1A-22	M1	L3
0	1A-24	K6	L2
0	1A-26	K4	M5
0	1A-28	L3	L1

ispMACH 51024VG Logic Signal Connections (Continued)

Bank No.	Signal	484 fpBGA	676 fpBGA
0	1A-30	K5	M3
0	GNDIO0	GND	GND
0	1B-30/CLK_OUT0	N1	M2
0	1B-28	M2	M1
0	1B-26	P1	N6
0	1B-24	L4	N5
0	1B-22	N2	N4
0	1B-20	M3	N3
0	1B-18	L5	N2
0	1B-16	R1	N1
0	1B-14	P2	P6
0	1B-12	N3	P4
0	GNDIO0	GND	GND
0	1B-10	M6	P3
0	1B-8	M5	P2
0	1B-6/PLL_RST0	M4	P1
0	1B-4/PLL_FBK0	N4	R4
0	1B-2	N6	R3
0	1B-0	N5	R2
1	2B-0	NC	R1
1	2B-2	NC	T1
1	2B-4	NC	T3
1	2B-6	NC	T2
1	2B-8	NC	U1
1	2B-10	NC	U2
1	GNDIO1	GND	GND
1	2B-12	NC	U3
1	2B-14	NC	U4
1	2B-16	NC	V1
1	2B-18	NC	V2
1	2B-20	NC	V3
1	2B-22	NC	V4
1	2B-24	NC	W1
1	2B-26	NC	V6
1	2B-28	NC	W2
1	2B-30	NC	W3
1	GNDIO1	GND	GND
1	2A-30	NC	Y1
1	2A-28	NC	W5
1	2A-26	NC	Y2
1	2A-24	NC	Y3
1	2A-22	NC	AA1
1	2A-20	NC	Y4

Bank No.	Signal	484 fpBGA	676 fpBGA
1	2A-18	NC	AA2
1	2A-16	NC	AA3
1	2A-14	NC	AB1
1	2A-12	NC	AB2
1	GNDIO1	GND	GND
1	2A-10	NC	AA5
1	2A-8	NC	AB3
1	2A-6	NC	AC1
1	2A-4	NC	AB4
1	2A-2	NC	AC2
1	2A-0	NC	AD1
1	3B-0	R5	AC3
1	3B-2	T2	AD2
1	3B-4	T5	AE1
1	3B-6	T3	AD3
1	3B-8	U1	AE2
1	3B-10	U4	AC5
1	GNDIO1	GND	GND
1	3B-12	V1	AF1
1	3B-14	U3	AD4
1	3B-16	V5	AE3
1	3B-18	V2	AC6
1	3B-20	W1	AF2
1	3B-22	V3	AG1
1	3B-24	W2	AF3
1	3B-26	Y1	AG2
1	3B-28	Y2	AH1
1	3B-30	W3	AE5
1	3A-30	AA3	AF4
1	3A-28	W4	AG3
1	GNDIO1	GND	GND
1	3A-26	W5	AE6
1	3A-24	Y4	AH2
1	3A-22	T6	AJ1
1	3A-20	Y5	AG4
1	3A-18	U6	AF6
1	3A-16	AA4	AG5
1	3A-14	NC	AH4
1	3A-12	NC	AJ3
1	GNDIO1	GND	GND
1	3A-10	NC	AK2
1	3A-8	NC	AE8
1	3A-6	W6	AH5

ispMACH 51024VG Logic Signal Connections (Continued)

Bank No.	Signal	484 fpBGA	676 fpBGA
1	3A-4	V4	AJ4
1	3A-2	U7	AK3
1	3A-0	AB2	AK4
1	3D-0	V7	AJ5
1	3D-2	AA5	AH6
1	GNDIO1	GND	GND
1	3D-4	AB3	AF8
1	3D-6	Y6	AG7
1	3D-8	AB4	AK5
1	3D-10	Y7	AJ6
1	3D-12	AB5	AH7
1	3D-14	V8	AK6
1	3D-16	AA7	AJ7
1	3D-18	Y8	AH8
1	3D-20	AB6	AG9
1	3D-22	W8	AK7
1	3D-24	AA8	AF10
1	3D-26	Y10	AJ8
1	GNDIO1	GND	GND
1	3D-28	U8	AH9
1	3D-30	AB7	AK8
1	3C-0	U9	AJ9
1	3C-2	AA9	AH10
1	3C-4	W9	AK9
1	3C-6	AB8	AG11
1	3C-8	U10	AJ10
1	3C-10	AB9	AF12
1	3C-12	V11	AH11
1	3C-14/VREF1	AA10	AK10
1	3C-16	V10	AJ11
1	3C-18	AB10	AK11
1	GNDIO1	GND	GND
1	3C-20	W10	AH12
1	3C-22	W11	AJ12
1	3C-24	U11	AK12
1	3C-26	AA11	AH13
1	3C-28	V12	AJ13
1	3C-30	AB11	AK13
2	4C-30	W12	AK18
2	4C-28	Y11	AK19
2	4C-26	Y12	AJ19
2	4C-24	AB12	AH19
2	4C-22	U12	AK20

Bank No.	Signal	484 fpBGA	676 fpBGA
2	4C-20	AA12	AJ20
2	GNDIO2	GND	GND
2	4C-18	Y13	AK21
2	4C-16	AB13	AH20
2	4C-14	W13	AF19
2	4C-12/VREF2	AA13	AJ21
2	4C-10	U13	AG20
2	4C-8	AB14	AK22
2	4C-6	V13	AH21
2	4C-4	AA14	AJ22
2	4C-2	U14	AK23
2	4C-0	AB15	AH22
2	4D-30	Y15	AJ23
2	4D-28	AB16	AK24
2	GNDIO2	GND	GND
2	4D-26	AA15	AF21
2	4D-24	W14	AG22
2	4D-22	AB17	AH23
2	4D-20	Y16	AJ24
2	4D-18	AA16	AK25
2	4D-16	Y17	AH24
2	4D-14	AB18	AJ25
2	4D-12	V15	AK26
2	4D-10	AB19	AJ26
2	4D-8	W15	AH25
2	4D-6	AB20	AG24
2	4D-4	AA18	AF23
2	GNDIO2	GND	GND
2	4D-2	U15	AK27
2	4D-0	W17	AK28
2	4A-0	U16	AJ27
2	4A-2	AA19	AH26
2	4A-4	V16	AE23
2	4A-6	AB21	AK29
2	4A-8	NC	AJ28
2	4A-10	NC	AH27
2	GNDIO2	GND	GND
2	4A-12	NC	AG26
2	4A-14	NC	AF25
2	4A-16	Y18	AJ29
2	4A-18	W18	AG27
2	4A-20	AA20	AJ30
2	4A-22	W19	AH29

ispMACH 51024VG Logic Signal Connections (Continued)

Bank No.	Signal	484 fpBGA	676 fpBGA
2	4A-24	Y19	AE25
2	4A-26	V19	AG28
2	GNDIO2	GND	GND
2	4A-28	Y21	AF27
2	4A-30	W20	AE26
2	4B-30	AA22	AH30
2	4B-28	W21	AG29
2	4B-26	Y22	AF28
2	4B-24	V20	AG30
2	4B-22	V21	AF29
2	4B-20	W22	AC25
2	4B-18	V18	AE28
2	4B-16	U20	AF30
2	4B-14	V22	AD27
2	4B-12	U19	AE29
2	GNDIO2	GND	GND
2	4B-10	U17	AC26
2	4B-8	U22	AD28
2	4B-6	T20	AE30
2	4B-4	T21	AD29
2	4B-2	T17	AC28
2	4B-0	R20	AD30
2	5A-0	NC	AC29
2	5A-2	NC	AB27
2	5A-4	NC	AC30
2	5A-6	NC	AB28
2	5A-8	NC	AA26
2	5A-10	NC	AB29
2	GNDIO2	GND	GND
2	5A-12	NC	AB30
2	5A-14	NC	AA28
2	5A-16	NC	AA29
2	5A-18	NC	AA30
2	5A-20	NC	Y27
2	5A-22	NC	Y28
2	5A-24	NC	Y29
2	5A-26	NC	W26
2	5A-28	NC	Y30
2	5A-30	NC	W28
2	GNDIO2	GND	GND
2	5B-30	NC	W29
2	5B-28	NC	W30
2	5B-26	NC	V25

Bank No.	Signal	484 fpBGA	676 fpBGA
2	5B-24	NC	V26
2	5B-22	NC	V27
2	5B-20	NC	V28
2	5B-18	NC	V29
2	5B-16	NC	V30
2	5B-14	NC	U25
2	5B-12	NC	U27
2	GNDIO2	GND	GND
2	5B-10	NC	U28
2	5B-8	NC	U29
2	5B-6	NC	U30
2	5B-4	NC	T27
2	5B-2	NC	T28
2	5B-0	NC	T29
3	6B-0	R21	T30
3	6B-2	T22	R29
3	6B4/PLL_FBK1	P21	R27
3	6B6/PLL_RST1	N20	R28
3	6B-8	R22	R30
3	6B-10	N21	P30
3	GNDIO3	GND	GND
3	6B-12	M18	P29
3	6B-14	N19	P28
3	6B-16	P22	P27
3	6B-18	M20	N30
3	6B-20	N22	N29
3	6B-22	N17	N28
3	6B-24	M19	N27
3	6B-26	M21	N25
3	6B-28	L19	M30
3	6B-30/CLK_OUT1	L20	M29
3	GNDIO3	GND	GND
3	6A-30	M17	M28
3	6A-28	M22	L30
3	6A-26	K20	M26
3	6A-24	L18	L29
3	6A-22	L21	L28
3	6A-20	K19	L27
3	6A-18	L22	K30
3	6A-16	K17	K29
3	6A-14	K22	K28
3	6A-12	L17	J30
3	GNDIO3	GND	GND

ispMACH 51024VG Logic Signal Connections (Continued)

Bank No.	Signal	484 fpBGA	676 fpBGA
3	6A-10	K21	J29
3	6A-8	K18	K26
3	6A-6	J17	J28
3	6A-4	J19	H30
3	6A-2	J22	J27
3	6A-0	J21	H29
3	7B-0	H19	G30
3	7B-2	H20	H28
3	7B-4	H17	G29
3	7B-6	H18	F30
3	7B-8	H22	G28
3	7B-10	H21	H26
3	GNDIO3	GND	GND
3	7B-12	G20	F29
3	7B-14	G22	G27
3	7B-16	G17	E30
3	7B-18	G21	F28
3	7B-20	F19	H25
3	7B-22	F20	E29
3	7B-24	F22	D30
3	7B-26	E22	E28
3	7B-28	E19	D29
3	7B-30	E20	C30
3	7A-30	D22	F26
3	7A-28	D21	E27
3	GNDIO3	GND	GND
3	7A-26	D20	D28
3	7A-24	C22	F25
3	7A-22	C18	C29
3	7A-20	C19	B30
3	7A-18	D17	D27
3	7A-16	C21	E25
3	7A-14	NC	D26
3	7A-12	NC	C27
3	GNDIO3	GND	GND
3	7A-10	NC	B28
3	7A-8	NC	A29
3	7A-6	B22	F23
3	7A-4	D18	C26
3	7A-2	B20	B27
3	7A-0	F17	A28
3	7D-0	B19	A27
3	7D-2	C17	B26

Bank No.	Signal	484 fpBGA	676 fpBGA
3	GNDIO3	GND	GND
3	7D-4	A21	E23
3	7D-6	D15	D24
3	7D-8	A20	C25
3	7D-10	C16	A26
3	7D-12	A19	B25
3	7D-14	F16	C24
3	7D-16	B16	A25
3	7D-18	D14	B24
3	7D-20	A18	C23
3	7D-22	F15	D22
3	7D-24	A17	A24
3	7D-26	B15	E21
3	GNDIO3	GND	GND
3	7D-28	A16	B23
3	7D-30	F14	C22
3	7C-0	C15	A23
3	7C-2	D13	B22
3	7C-4	E15	C21
3	7C-6	F13	A22
3	7C-8	B14	D20
3	7C-10	E13	B21
3	7C-12/VREF3	A15	E19
3	7C-14	D12	C20
3	7C-16	A14	A21
3	7C-18	B13	B20
3	GNDIO3	GND	GND
3	7C-20	A13	A20
3	7C-22	B12	C19
3	7C-24	C13	B19
3	7C-26	A12	A19
3	7C-28	C12	B18
3	7C-30	A11	A18
—	GCLK0	P6	R5
—	GCLK1	R6	T6
—	GCLK2	P17	R25
—	GCLK3	P19	P26
—	GOE0	R18	T26
—	GOE1	R17	R26
—	RESETB	R19	T25
—	TCK	R3	U5
—	TDI	R2	T5
—	TDO	R4	V5

ispMACH 51024VG Logic Signal Connections (Continued)

Bank No.	Signal	484 fpBGA	676 fpBGA
—	TMS	T1	T4
—	TOE	T18	U26

Signal Configuration

ispMACH 5768VG 256-ball fpBGA

	16	15	14	13	12	11	10	9	8	7	6	5	4	3	2	1	
A	I/O	I/O	I/O	I/O	I/O	I/O	I/O	I/O	I/O/ VREF3	I/O	I/O	I/O	I/O	I/O	I/O	GND	A
B	I/O	I/O	I/O	I/O	I/O	I/O/ CLK_OUT1	I/O	I/O	I/O	I/O	I/O	I/O	I/O	I/O	I/O	I/O	B
C	I/O	I/O	VCCO3	I/O	GND	I/O	VCCO3	I/O	I/O	VCCO0	I/O	GND	I/O	VCCO0	I/O	I/O	C
D	I/O	I/O	I/O	I/O	I/O	I/O	I/O	I/O	I/O	I/O	I/O	I/O	I/O	I/O	I/O	I/O	D
E	I/O	I/O	GND	I/O	I/O	I/O	I/O	I/O	I/O	I/O/ VREF0	I/O	I/O	I/O	GND	I/O	I/O	E
F	I/O	I/O	I/O	I/O	I/O	I/O	I/O	VCC	VCC	I/O	I/O	I/O	I/O	I/O	I/O	I/O/ PLL_RST0	F
G	I/O	I/O/ PLL_FBK1	VCCO3	I/O	I/O	I/O	GND	GND	GND	GND	I/O/ CLK_OUT0	I/O	I/O	VCCO0	I/O/ PLL_FBK0	I/O	G
H	VCCP1	GOE1	GCLK2	GCLK3	I/O/ PLL_RST1	VCC	GND	GND	GND	GNDP0	VCC	I/O	GCLK0	TDI	TMS	VCCP0	H
J	I/O	GOE0	RESETB	TOE	I/O	VCC	GNDP1	GND	GND	GND	VCC	I/O	GCLK1	TCK	TDO	VCCJ	J
K	I/O	I/O	VCCO2	I/O	I/O	I/O	GND	GND	GND	GND	I/O	I/O	I/O	VCCO1	I/O	I/O	K
L	I/O	I/O	I/O	I/O	I/O	I/O	I/O	VCC	VCC	I/O	I/O	I/O	I/O	I/O	I/O	I/O	L
M	I/O	I/O	GND	I/O	I/O	I/O	I/O	I/O	I/O	I/O/ VREF1	I/O	I/O	I/O	GND	I/O	I/O	M
N	I/O	I/O	I/O	I/O	I/O	I/O	I/O	I/O	I/O	I/O	I/O	I/O	I/O	I/O	I/O	I/O	N
P	I/O	I/O	VCCO2	I/O	GND	I/O	VCCO2	I/O	I/O	VCCO1	I/O	GND	I/O	VCCO1	I/O	I/O	P
R	I/O	I/O	I/O	I/O/ VREF2	I/O	I/O	I/O	I/O	I/O	I/O	I/O	I/O	I/O	I/O	I/O	I/O	R
T	I/O	I/O	I/O	I/O	I/O	I/O	I/O	I/O	I/O	I/O	I/O	I/O	I/O	I/O	I/O	I/O	T

ispMACH 5768VG

Bottom View

256fpBGA/5768VG

Note: Ball A1 indicator dot on top side of package.

Signal Configuration

ispMACH 5768VG and 51024VG 484-ball fpBGA

	22	21	20	19	18	17	16	15	14	13	12	11	10	9	8	7	6	5	4	3	2	1		
A	GND	I/O	I/O	I/O	I/O	I/O	I/O	I/O/ VREF3	I/O	I/O	I/O	I/O	I/O	I/O/ VREF0	I/O	I/O	I/O	I/O	I/O	I/O	I/O	I/O	GND	A
B	I/O	VCC	I/O	I/O	VCC03	VCC	I/O	I/O	I/O	I/O	I/O	I/O	I/O	I/O	I/O	VCC	VCC00	I/O	I/O	VCC	I/O	I/O	B	
C	I/O	I/O	GND	I/O	I/O	I/O	I/O	I/O	VCC	I/O	I/O	I/O	I/O	VCC	I/O	I/O	I/O	I/O	I/O	GND	I/O	I/O	C	
D	I/O	I/O	I/O	GND	I/O	I/O	VCC03	I/O	I/O	I/O	I/O	I/O	I/O	I/O	I/O	VCC00	I/O	I/O	GND	I/O	I/O	I/O	D	
E	I/O	VCC03	I/O	I/O	VCC	VCC03	GND	I/O	VCC03	I/O	I/O	I/O	I/O	VCC00	I/O	GND	VCC00	VCC	I/O	I/O	VCC00	I/O	E	
F	I/O	VCC	I/O	I/O	VCC03	I/O	I/O	I/O	I/O	I/O	I/O	I/O	I/O	I/O	I/O	I/O	I/O	VCC00	I/O	I/O	VCC	I/O	F	
G	I/O	I/O	I/O	VCC03	GND	I/O	GND	GND	GND	GND	GND	GND	GND	GND	GND	GND	I/O	GND	VCC00	I/O	I/O	I/O	G	
H	I/O	I/O	I/O	I/O	I/O	I/O	GND	GND	GND	GND	GND	GND	GND	GND	GND	GND	I/O	I/O	I/O	I/O	I/O	I/O	H	
J	I/O	I/O	VCC	I/O	VCC03	I/O	GND	GND	GND	GND	GND	GND	GND	GND	GND	GND	I/O	VCC00	I/O	VCC	I/O	I/O	J	
K	I/O	I/O	I/O	I/O	I/O	I/O	GND	GND	GND	GND	GND	GND	GND	GND	GND	GND	I/O	I/O	I/O	I/O	I/O	I/O	K	
L	I/O	I/O	I/O/ CLK_OUT1	I/O	I/O	I/O	GNDP1	GND	GND	GND	GND	GND	GND	GND	GND	GND	VCCP0	GNDP0	I/O	I/O	I/O	I/O	L	
M	I/O	I/O	I/O	I/O	I/O	I/O	GND	GND	GND	GND	GND	GND	GND	GND	GND	GND	I/O	I/O	I/O/ PLL_RST0	I/O	I/O	I/O	M	
N	I/O	I/O	I/O/ PLL_RST1	I/O	VCCP1	I/O	GND	GND	GND	GND	GND	GND	GND	GND	GND	GND	I/O	I/O	I/O/ PLL_FBK0	I/O	I/O	I/O/ CLK_OUT0	N	
P	I/O	I/O/ PLL_FBK1	VCC	GCLK3	VCC02	GCLK2	GND	GND	GND	GND	GND	GND	GND	GND	GND	GND	GCLK0	VCC01	VCCJ	VCC	I/O	I/O	P	
R	I/O	I/O	I/O	RESETB	GOE0	GOE1	GND	GND	GND	GND	GND	GND	GND	GND	GND	GND	GCLK1	I/O	TDO	TCK	TDI	I/O	R	
T	I/O	I/O	I/O	GND	TOE	I/O	GND	GND	GND	GND	GND	GND	GND	GND	GND	GND	I/O	I/O	GND	I/O	I/O	TMS	T	
U	I/O	VCC	I/O	I/O	VCC02	I/O	I/O	I/O	I/O	I/O	I/O	I/O	I/O	I/O	I/O	I/O	I/O	VCC01	I/O	I/O	VCC	I/O	U	
V	I/O	I/O	I/O	I/O	I/O	VCC02	I/O	I/O	VCC02	I/O	I/O	I/O	I/O	VCC01	I/O	I/O	VCC01	I/O	I/O	I/O	I/O	I/O	V	
W	I/O	I/O	I/O	I/O	I/O	I/O	GND	I/O	I/O	I/O	I/O	I/O	I/O	I/O	I/O	GND	I/O	I/O	I/O	I/O	I/O	I/O	W	
Y	I/O	I/O	VCC02	I/O	I/O	I/O	I/O	I/O	VCC	I/O	I/O	I/O	I/O	VCC	I/O	I/O	I/O	I/O	I/O	VCC01	I/O	I/O	Y	
AA	I/O	VCC	I/O	I/O	I/O	VCC	I/O	I/O	I/O	I/O/ VREF2	I/O	I/O	I/O/ VREF1	I/O	I/O	I/O	VCC	I/O	I/O	I/O	VCC	NC ¹	AA	
AB	GND	I/O	I/O	I/O	I/O	I/O	I/O	I/O	I/O	I/O	I/O	I/O	I/O	I/O	I/O	I/O	I/O	I/O	I/O	I/O	I/O	I/O	AB	

ispMACH 5768VG and 51024VG

484BGA/51024VG

Bottom View

1. NCs are not to be connected to any active signals, VCC or GND.

Note: Ball A1 indicator dot on top side of package.

Part Number Description

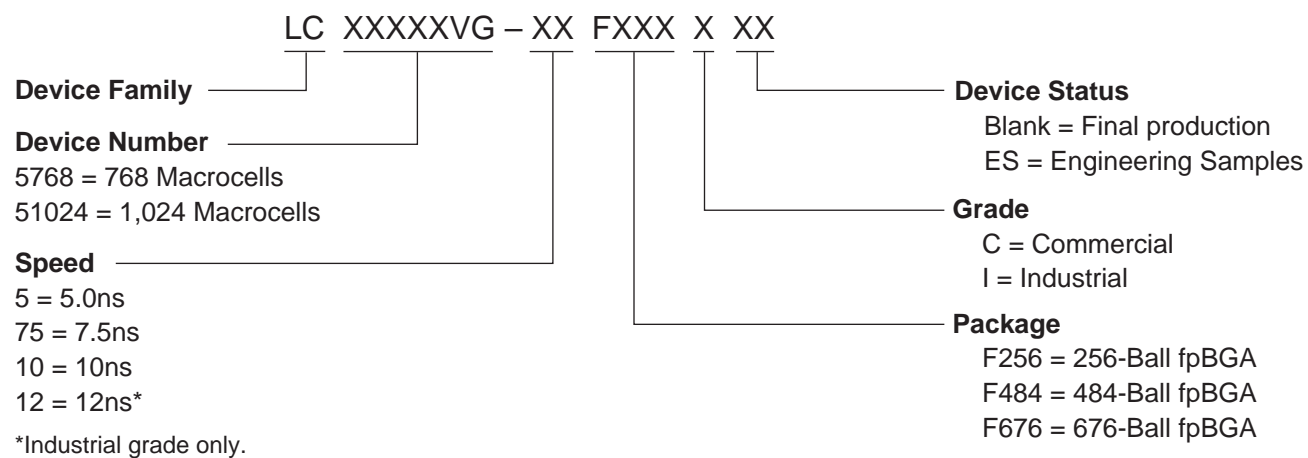

0212/isp5vg

Ordering Information

Commercial

Part Number	Package	Pin Count	Macrocells	Tpd	Voltage
LC51024VG-5F484C	fpBGA	484	1024	5	3.3
LC51024VG-75F484C	fpBGA	484	1024	7.5	3.3
LC51024VG-10F484C	fpBGA	484	1024	10	3.3
LC51024VG-5F676C	fpBGA	676	1024	5	3.3
LC51024VG-75F676C	fpBGA	676	1024	7.5	3.3
LC51024VG-10F676C	fpBGA	676	1024	10	3.3
LC5768VG-5F256C	fpBGA	256	768	5	3.3
LC5768VG-75F256C	fpBGA	256	768	7.5	3.3
LC5768VG-10F256C	fpBGA	256	768	10	3.3
LC5768VG-5F484C	fpBGA	484	768	5	3.3
LC5768VG-75F484C	fpBGA	484	768	7.5	3.3
LC5768VG-10F484C	fpBGA	484	768	10	3.3

Note: the ispMACH 5000VG family is dual-marked with both Commercial and Industrial grades. The Commercial speed grade is one speed grade faster (i.e. LC51024VG-75F484C) than the Industrial speed grade (i.e. LC51024VG-10F484I).

Industrial

Part Number	Package	Pin Count	Macrocells	Tpd	Voltage
LC51024VG-75F484I	fpBGA	484	1024	7.5	3.3
LC51024VG-10F484I	fpBGA	484	1024	10	3.3
LC51024VG-12F484I	fpBGA	484	1024	12	3.3
LC51024VG-75F676I	fpBGA	676	1024	7.5	3.3
LC51024VG-10F676I	fpBGA	676	1024	10	3.3
LC51024VG-12F676I	fpBGA	676	1024	12	3.3
LC5768VG-75F256I	fpBGA	256	768	7.5	3.3
LC5768VG-10F256I	fpBGA	256	768	10	3.3
LC5768VG-12F256I	fpBGA	256	768	12	3.3
LC5768VG-75F484I	fpBGA	484	768	7.5	3.3
LC5768VG-10F484I	fpBGA	484	768	10	3.3
LC5768VG-12F484I	fpBGA	484	768	12	3.3

Note: the ispMACH 5000VG family is dual-marked with both Commercial and Industrial grades. The Commercial speed grade is one speed grade faster (i.e. LC51024VG-75F484C) than the Industrial speed grade (i.e. LC51024VG-10F484I).

For Further Information

In addition to this data sheet, the following technical notes may be helpful when designing with the ispMACH 5000VG family:

- *ispMACH 5000VG sysIO Design and Usage Guidelines* (TN1000)
- *ispMACH 5000VG Timing Model Design and Usage Guidelines* (TN1001)
- *Power Estimation in ispMACH 5000VG Devices* (TN1002)
- *ispMACH 5000VG PLL Usage Guidelines* (TN1003)

Looking for pricing, stock, or lifecycle information?

Click below to explore more details on WIN SOURCE:

- [View LC51024VG-75F484C on WIN SOURCE](#)
- [Lattice Semiconductor Corporation Information](#)

Optimize Your Supply Chain with WIN SOURCE Solutions

- ✓ Global Sourcing Solution
- ✓ Obsolete Management
- ✓ Cost Control Management
- ✓ Shortage Management
- ✓ Alternative Solution
- ✓ Excess Inventory Management