



ON Semiconductor®

<http://onsemi.com>

LB1940T

Monolithic Digital IC 2-ch H-Bridge Constant Current Driver

Overview

The LB1940T is 2-phase exciter type bipolar stepper motor driver ICs that feature low-voltage, (supporting 3V battery) and low current operation with low saturation voltage. This IC enable constant-current control of actuators, and are optimal for driving the actuators of PC peripherals such as USB compatible scanners, FDDs, and printers, as well as for controlling the shutter, iris, and AF of a digital still camera.

Features

- Low-voltage driving
2-power source type: $V_S = 1.6$ to $7.5V$, $V_{DD} = 1.9$ to $6.5V$
Single power source type: $V_S = V_{DD} = 1.9$ to $7.5V$
- Low saturation output: $V_{O(sat)} = 0.3V$ at I_O of 200mA
- Constant-current control
- Built-in reference voltage ($V_{ref} = 0.9V$)
- Small-sized, low-profile package (TSSOP20; 225mil; thickness (t) = 1.2mm max.)

Specifications

Absolute Maximum Ratings at $T_a = 25^\circ C$

Parameter	Symbol	Conditions	Ratings	Unit
Maximum supply voltage	V_B max	V_{S1} , V_{S2} , V_{DD}	-0.3 to +10.5	V
Output applied voltage	V_{OUT} max	OUT1, OUT2, OUT3, OUT4	-0.3 to +10.5	V
Output Current	I_O max		400	mA
Input applied voltage	V_{IN} max	ENA1, ENA2, IN1, IN2, VC	-0.3 to +10.5	V
Allowable power dissipation	P_d max	Mounted on a specified board *	800	mW
Operating temperature	T_{opr}		-20 to +85	$^\circ C$
Storage temperature	T_{stg}		-55 to +150	$^\circ C$

* Mounted on a Specified board: 114.3mm×76.1mm×1.6mm, glass epoxy

Stresses exceeding Maximum Ratings may damage the device. Maximum Ratings are stress ratings only. Functional operation above the Recommended Operating Conditions is not implied. Extended exposure to stresses above the Recommended Operating Conditions may affect device reliability.

ORDERING INFORMATION

See detailed ordering and shipping information on page 8 of this data sheet.

LB1940T

Allowable Operating Range at $T_a = 25^\circ\text{C}$

Parameter	Symbol	Conditions	Ratings			unit
			min	typ	max	
Function-guaranteed voltage range	VOPR1	V_{DD} system, $V_S = 2.0\text{V}$	1.9		6.5	V
	VOPR2	V_S system, $V_{DD} = 5.0\text{V}$	1.6		7.5	
Low level input threshold voltage	V_{IL}	ENA1, ENA2, IN1, IN2	-0.3		1.0	V
High level input threshold voltage	V_{IH}	ENA1, ENA2, IN1, IN2	2.0		6.0	V
VC input voltage	VC		0.19		1.0	V

Electrical Characteristics at $T_a = 25^\circ\text{C}$, $V_S = 3\text{V}$, $V_{DD} = 5\text{V}$

Parameter	Symbol	Conditions	Ratings			unit
			min	typ	max	
Standby current dissipation	ISTB	$V_S = V_{DD} = 6.5\text{V}$		0.1	1.0	μA
Regulator output circuit						
VREF output voltage	VREF	$I_{OL} = 0$ to 1mA	0.85	0.9	0.95	V
SVDD output voltage	VSDD	$I_{OL} = 10\text{mA}$	4.70	4.85		V
H bridge output circuit						
OUT output saturation voltage (at saturation control)	$V_{O(\text{sat})1}$	$V_{DD} = 5.0\text{V}$, $V_S = 2.0\text{V}$ $I_O = 200\text{mA}$ (PNP side)		0.20	0.30	V
	$V_{O(\text{sat})2}$	$V_{DD} = 5.0\text{V}$, $V_S = 2.0\text{V}$ $I_O = 200\text{mA}$ (NPN side)		0.10	0.15	V
OUT output current (at constant current control)	I_{OUT1}	$V_{DD} = 6.0\text{V}$, $V_C = 0.2\text{V}$, $V_S = 3.5\text{V}$ $R_L = 5\Omega$ (between OUT-OUT), $R_{FB} = 2\Omega$	94	100	106	mA
	I_{OUT2}	$V_C = \frac{R_b}{R_a + R_b} V_{REF}$ ($R_a = 70\text{k}\Omega$, $R_b = 20\text{k}\Omega$) * $V_{DD} = 6.0\text{V}$, $V_S = 2.0\text{V}$ $R_L = 5\Omega$ (between OUT-OUT), $R_{FB} = 1\Omega$	180	200	220	mA
VS system operating current consumption	IS1	$V_C = \frac{R_b}{R_a + R_b} V_{REF}$ ($R_a = 70\text{k}\Omega$, $R_b = 20\text{k}\Omega$) *		1.5	3	mA
V_{DD} system operating current dissipation	I_{DD1}	$V_C = \frac{R_b}{R_a + R_b} V_{REF}$ ($R_a = 70\text{k}\Omega$, $R_b = 20\text{k}\Omega$) * ENA1 = 2V		4	7	mA
VC input current	IVC	$V_{DD} = 6.0\text{V}$, $V_S = 2.0\text{V}$, $V_C = 1.9\text{V}$	0		-1	μA
Control input circuit						
Control pin maximum input current	I_{IH}	$V_{IH} = 5.5\text{V}$		80	100	μA
	I_{IL}	$V_{IL} = \text{GND}$	-1		0	

* For R_a and R_b , refer to Application Circuit Diagram.

LB1940T

Package Dimensions

unit : mm (typ)

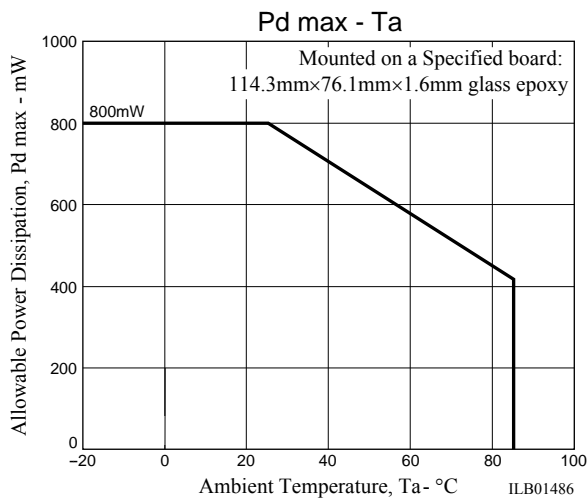
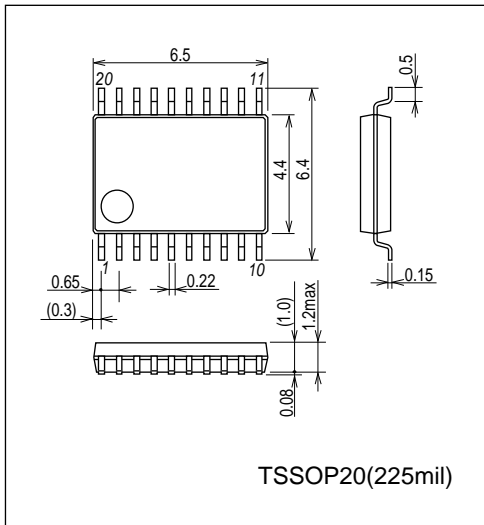

True Table

Input				Output				SVDD	Mode
ENA		IN		OUT					
1	2	1	2	1	2	3	4		
L	L								Standby (current dissipation zero)
H		H		L	H			on	Reverse rotation
		L		H	L			on	Forward rotation
	H		H			L	H	on	Reverse rotation
			L			H	L	on	Forward rotation
A blank means "don't care".				A blank means "off".					

LB1940T

Pin Assignment

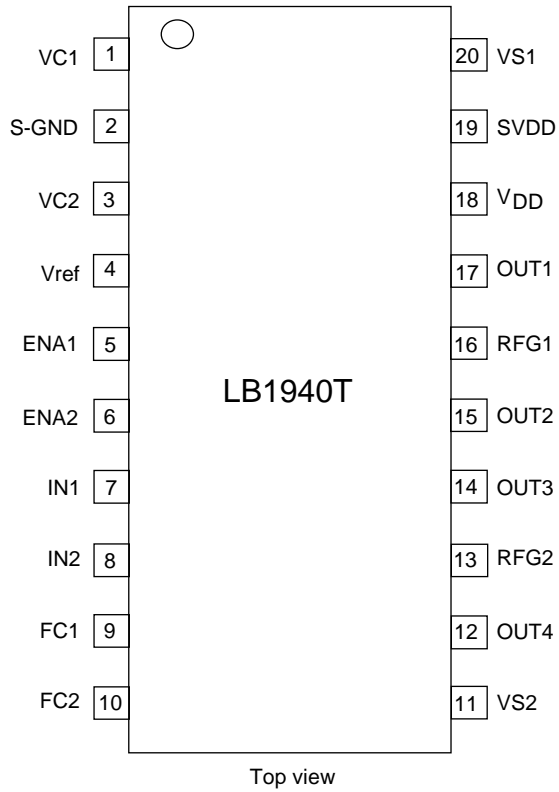

Pin Description

Pin No. LB1940T	Pin Name	Description	Pin No. LB1940T	Pin Name	Description
1	VC1	Reference voltage input for 1ch control	11	VS2	Motor power supply (+)
2	S-GND	GND for control system	12	OUT4	Motor drive output 4
3	VC2	Reference voltage input for 2ch control	13	RFG2	Constant-current detection pin
4	Vref	Reference voltage output	14	OUT3	Motor drive output 3
5	ENA1	Signal input for 1ch control	15	OUT2	Motor drive output 2
6	ENA2	Signal input for 2ch control	16	RFG1	Constant-current detection pin 1
7	IN1	Signal input for 1ch control	17	OUT1	Motor drive output 1
8	IN2	Signal input for 2ch control	18	V _{DD}	Control system power supply (+)
9	FC1	C connection pin for 1ch phase compensation	19	SVDD	Control system power output
10	FC2	C connection pin for 2ch phase compensation	20	VS1	Motor power supply (+)

LB1940T

Block Diagram

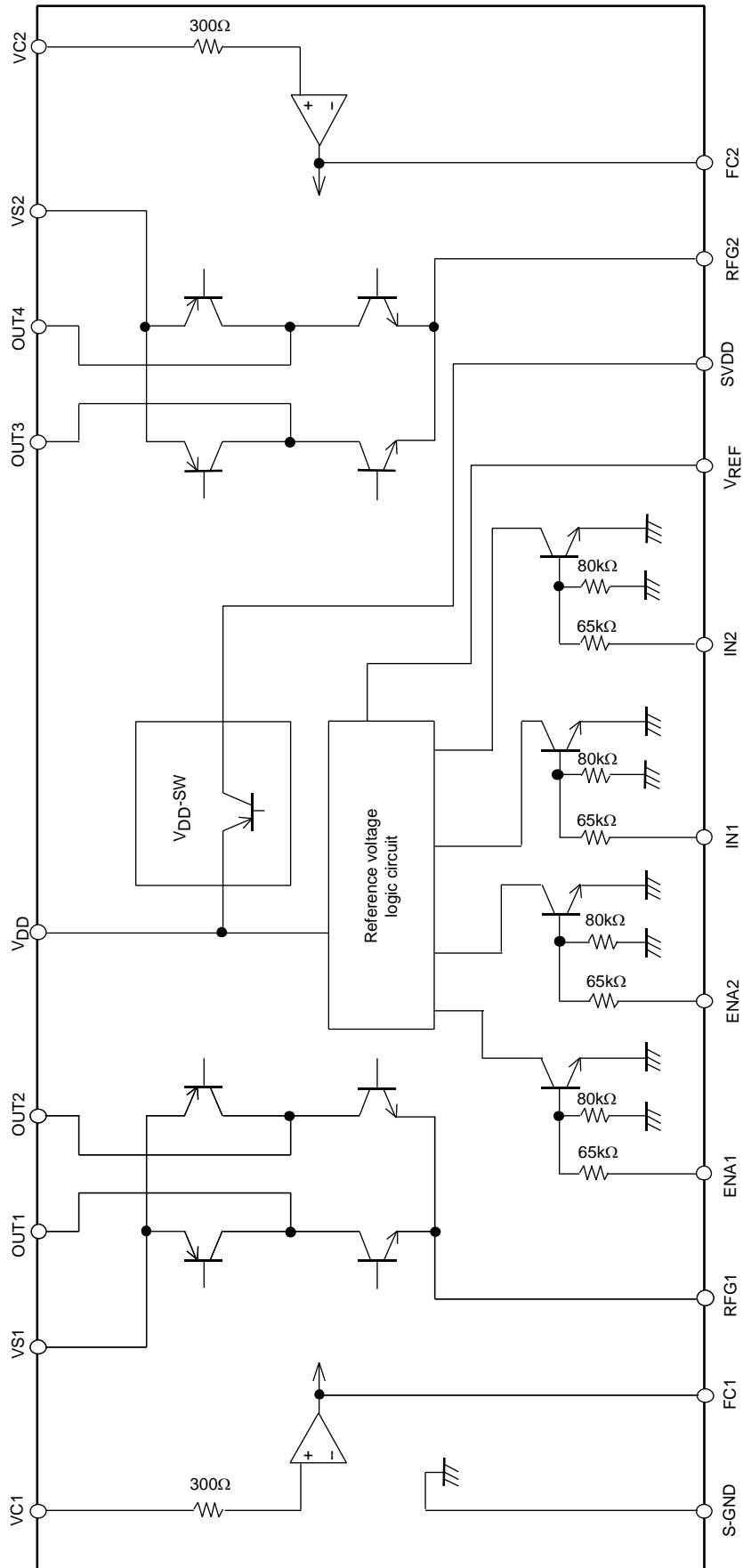

Application Circuit Diagram

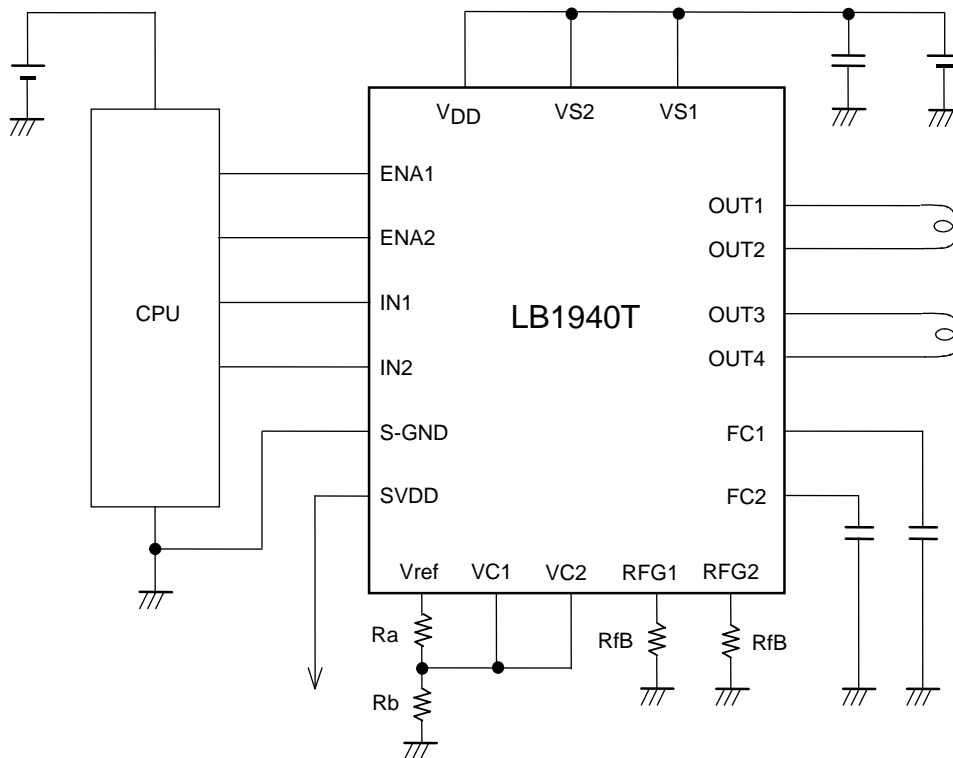

At constant-current control: The OUT current is controlled so that the RFG pin voltage is equal to the VC input pin voltage.

For example, $I_{OUT} = 200\text{mA} (= 0.2\text{V}/1\Omega)$ when $VC = 0.2\text{V}$ and $R_{FB} = 1\Omega$.

*: There is no priority relationship between respective input voltages (ENA, IN) and respective supply voltages (V_{DD} , VS). For example, operation with $V_{IN} = 5\text{V}$, $V_{DD} = 3\text{V}$, $VS = 2\text{V}$ is possible.

Note: The input voltage range to the reference voltage input pin VC for constant-current setting is from 0.19V to 1.0V.

Constant current setting

The composition of the constant-control circuit of this IC is as shown in the figure below.

The voltage entered in the VC pin is entered as a reference to the “+” side input of the constant-current control amplifier.

The “-” side of this constant-current control amplifier is connected to the RFG pin via the wire bonded resistor $R_b (= 0.1\Omega)$.

The constant-current control circuit consists of comparison of the voltage generated at the external current detection resistor with the above reference voltage.

In addition, since the bias current $I_b (= 1.5\mu\text{A})$ flows out of the positive (+) input of the constant current control amplifier during the constant current control, if the voltage is input to the VC pin by dividing the VREF voltage by 4.5 according to the dividing resistance (70kΩ and 20kΩ) as shown in the figure, the formula for calculating the VC voltage is as follows :

$$VC = V_{REF}/4.5 + I_b \times 20\text{k}\Omega = V_{REF}/4.5 + 0.03$$

Therefore, the theoretical equation to set the constant current I_{OUT} is as follows:

$$I_{OUT} = VC / (R_{FB} + R_b) = (V_{REF}/4.5 + 0.03) / (R_{FB} + R_b)$$

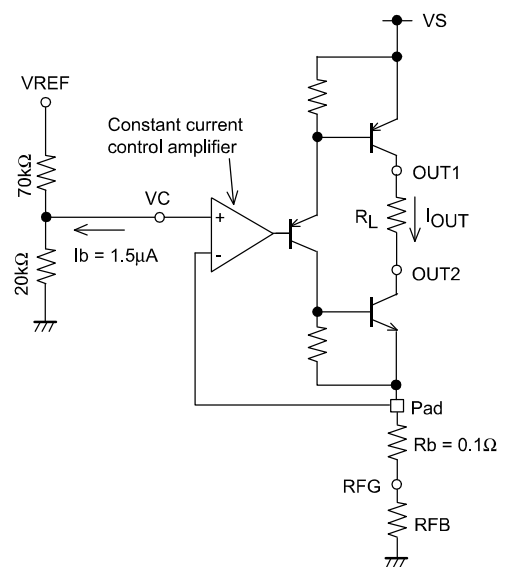

LB1940T

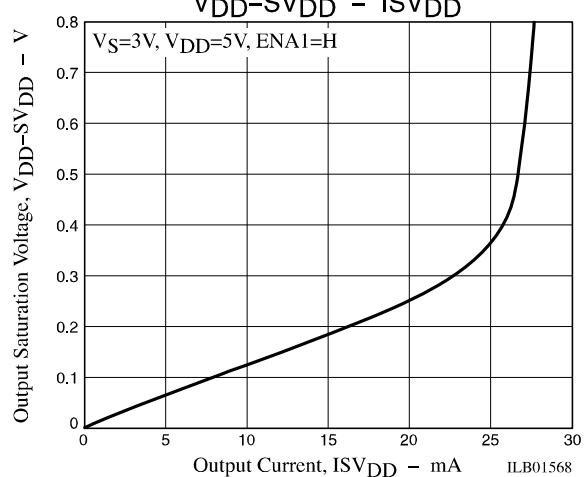
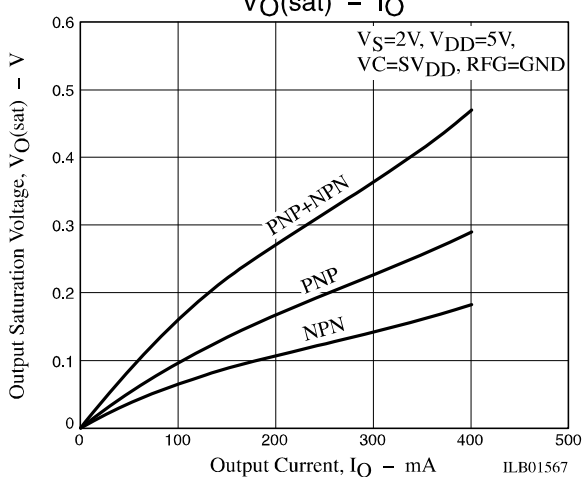
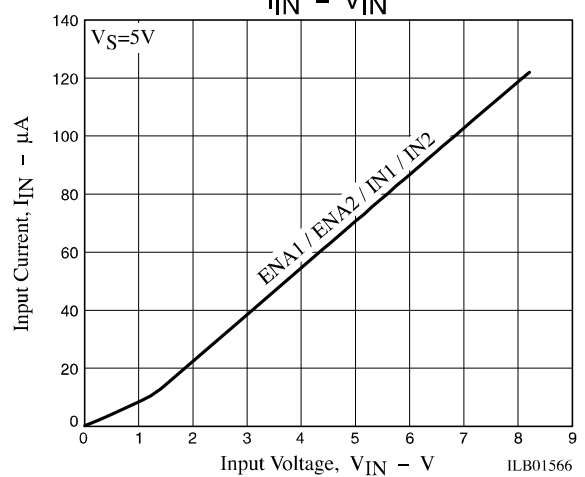
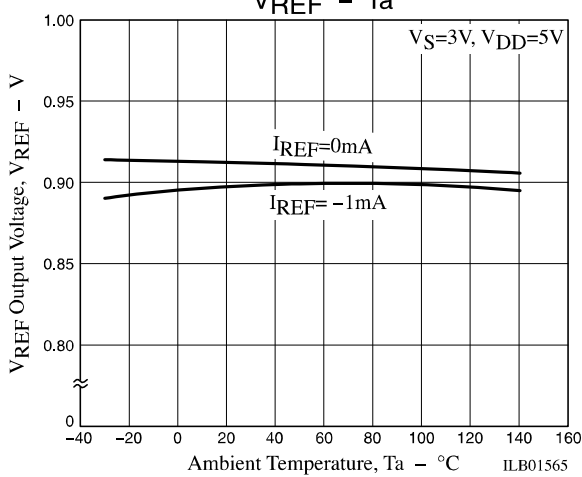
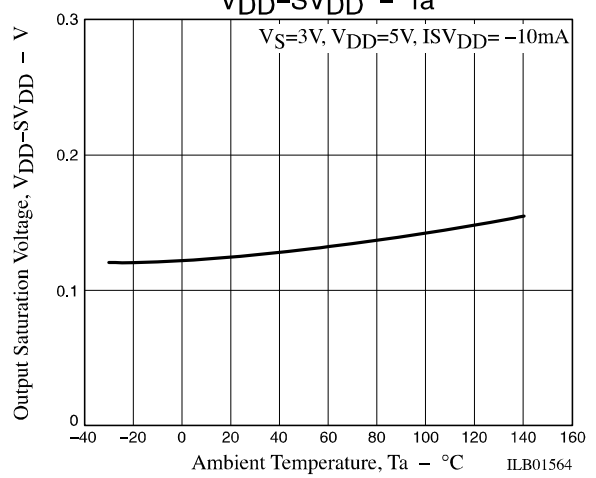
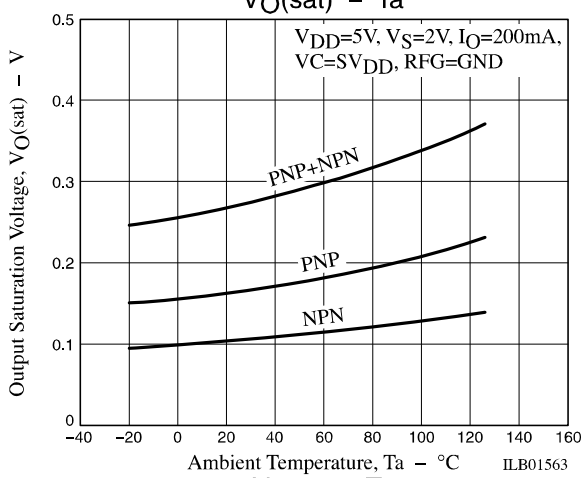
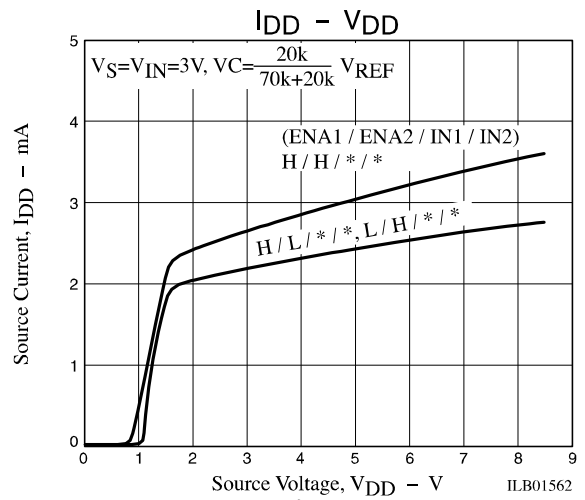
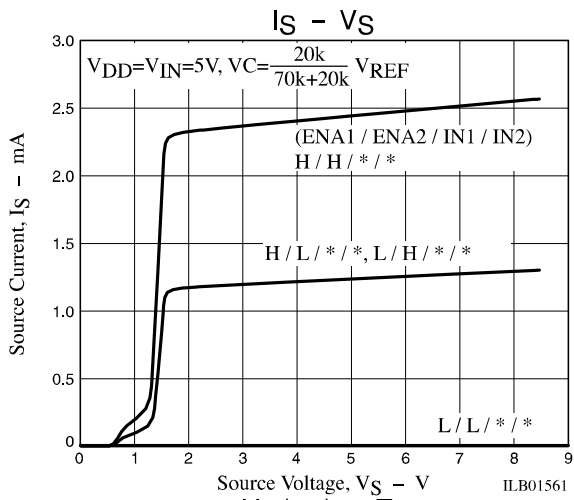

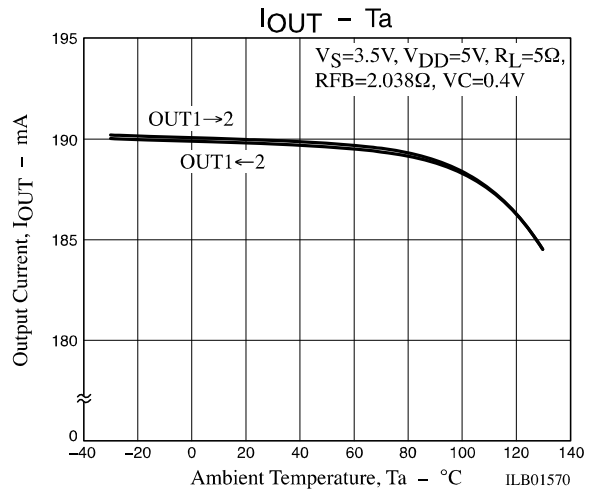
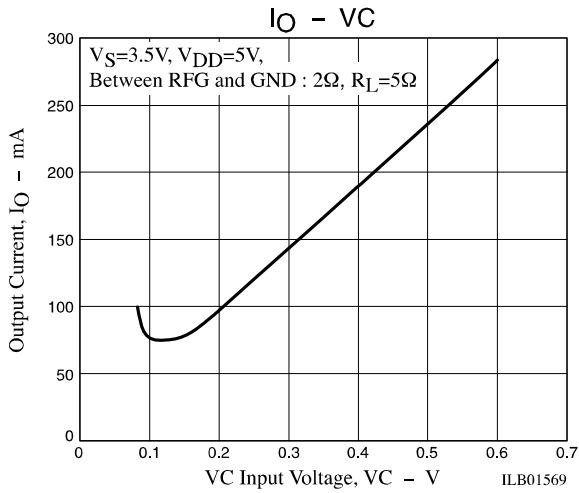



ORDERING INFORMATION

Device	Package	Shipping (Qty / Packing)
LB1940T-MPB-E	TSSOP20(225mil) (Pb-Free)	70 / Fan-Fold
LB1940T-MPB-H	TSSOP20(225mil) (Pb-Free / Halogen Free)	70 / Fan-Fold
LB1940T-TLM-H	TSSOP20(225mil) (Pb-Free / Halogen Free)	2000 / Tape and Reel

ON Semiconductor and the ON logo are registered trademarks of Semiconductor Components Industries, LLC (SCILLC). SCILLC owns the rights to a number of patents, trademarks, copyrights, trade secrets, and other intellectual property. A listing of SCILLC's product/patent coverage may be accessed at www.onsemi.com/site/pdf/Patent-Marking.pdf. SCILLC reserves the right to make changes without further notice to any products herein. SCILLC makes no warranty, representation or guarantee regarding the suitability of its products for any particular purpose, nor does SCILLC assume any liability arising out of the application or use of any product or circuit, and specifically disclaims any and all liability, including without limitation special, consequential or incidental damages. "Typical" parameters which may be provided in SCILLC data sheets and/or specifications can and do vary in different applications and actual performance may vary over time. All operating parameters, including "Typicals" must be validated for each customer application by customer's technical experts. SCILLC does not convey any license under its patent rights nor the rights of others. SCILLC products are not designed, intended, or authorized for use as components in systems intended for surgical implant into the body, or other applications intended to support or sustain life, or for any other application in which the failure of the SCILLC product could create a situation where personal injury or death may occur. Should Buyer purchase or use SCILLC products for any such unintended or unauthorized application, Buyer shall indemnify and hold SCILLC and its officers, employees, subsidiaries, affiliates, and distributors harmless against all claims, costs, damages, and expenses, and reasonable attorney fees arising out of, directly or indirectly, any claim of personal injury or death associated with such unintended or unauthorized use, even if such claim alleges that SCILLC was negligent regarding the design or manufacture of the part. SCILLC is an Equal Opportunity/Affirmative Action Employer. This literature is subject to all applicable copyright laws and is not for resale in any manner.

Looking for pricing, stock, or lifecycle information?

Click below to explore more details on WIN SOURCE:

-  [View LB1940T-TLM-H on WIN SOURCE](#)
-  [ON Semiconductor](#) Information

Optimize Your Supply Chain with WIN SOURCE Solutions

-  Global Sourcing Solution
-  Obsolete Management
-  Cost Control Management
-  Shortage Management
-  Alternative Solution
-  Excess Inventory Management