



**THE DATASHEET OF
LB1836M-TLM-E**





LB1836M

Monolithic Digital IC

Low-Saturation Bi-directional Motor Driver for Low-Voltage Drive Application Note

ON Semiconductor®

<http://onsemi.com>

Overview

The LB1836M is a low-saturation two-channel bidirectional motor driver IC for use in low-voltage applications.

The LB1836M is a bipolar stepper-motor driver IC that is ideal for use in printers, FDDs, cameras and other portable devices.

Functions

- Low voltage operation (2.5V min)
- Low saturation voltage (upper transistor + lower transistor residual voltage ; 0.40V typ at 400mA).
- Parallel connection (Upper transistor + lower transistor residual voltage ; 0.5V typ at 800mA).
- Separate logic power supply and motor power supply
- Brake function
- Spark killer diodes built in
- Thermal shutdown circuit built in
- Compact package (14-pin MFP)

Typical Applications

- Automotive audio
- Security camera
- Camera
- TOY
- POS, Card Terminal (POS Printer, Thermal printer)

Pin Assignment

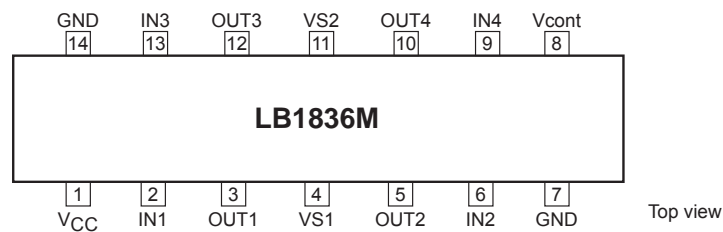

Note) Ground both GND pins.

LB1836M Application Note

Package Dimensions

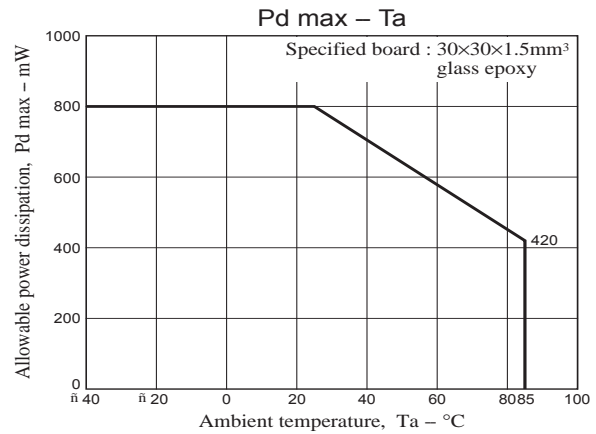
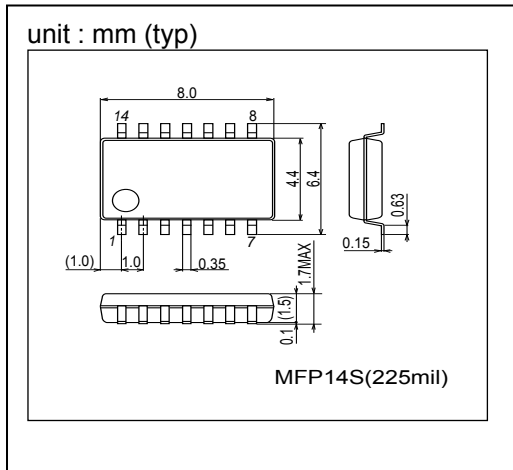

Recommended Soldering Footprint

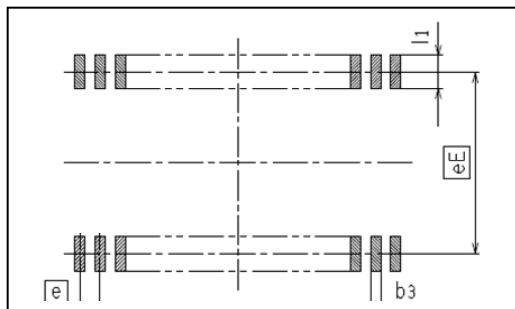

(Unit:mm)

Reference Symbol	MFP10S (225mil)
eE	5.70
e	1.00
b3	0.47
l1	1.10

Block Diagram

1. Two-DC motor drive

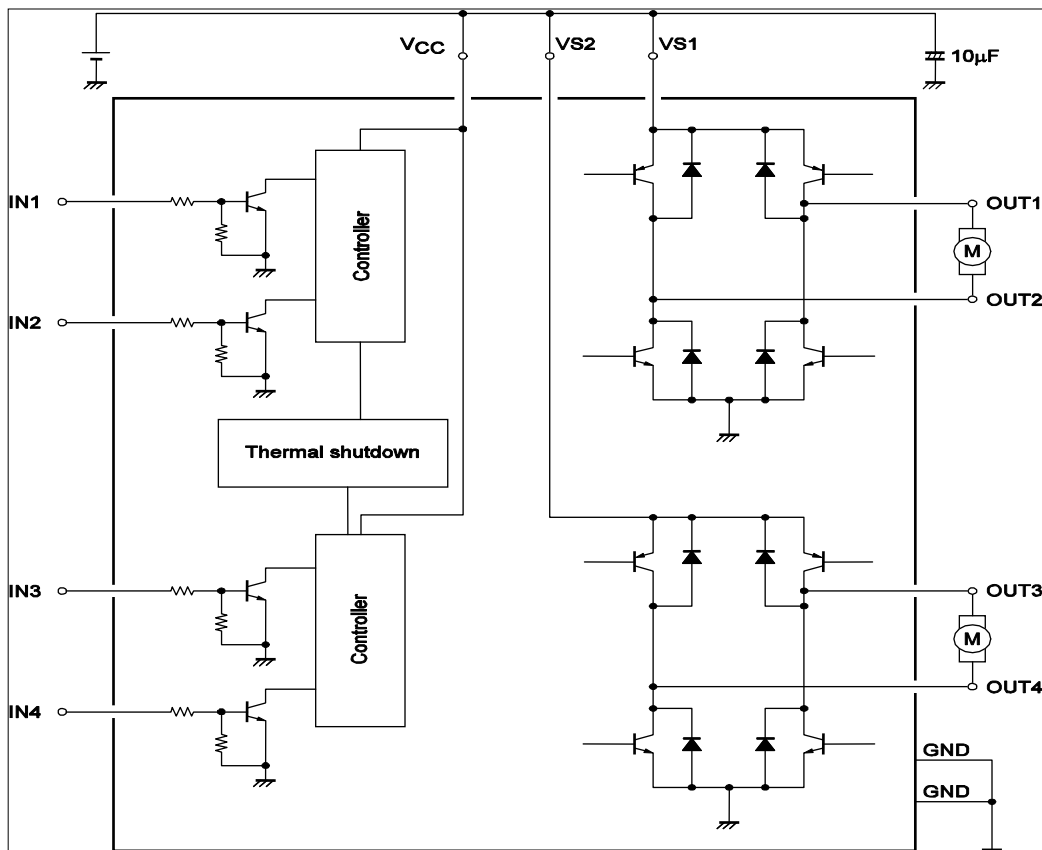

LB1836M Application Note

2. Single stepping motor drive

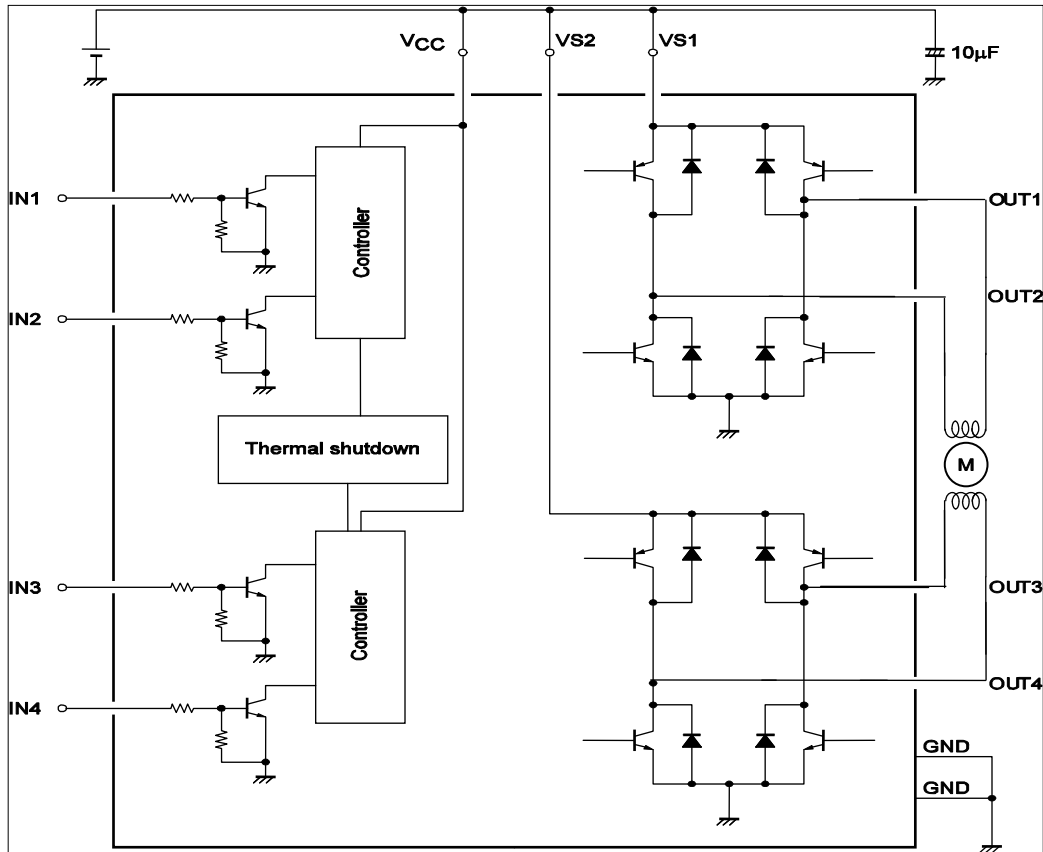

Specifications

Absolute Maximum Ratings at $T_a = 25^\circ\text{C}$

Parameter	Symbol	Conditions	Ratings	Unit
Maximum supply voltage	$V_{CC \text{ max}}$		-0.3 to +10.5	V
	$V_S \text{ max}$		-0.3 to +10.5	V
Output supply voltage	V_{OUT}		$V_S + V_{SF}$	V
Input supply voltage	V_{IN}		-0.3 to +10	V
GND pin flow-out current	IGND	Per channel	1.0	A
Allowable power dissipation	$P_d \text{ max}$	* Mounted on a board.	800	mW
Operating temperature	T_{opr}		-40 to +85	$^\circ\text{C}$
Storage temperature	T_{stg}		-55 to +150	$^\circ\text{C}$

* Mounted on a substrate: $30 \times 30 \times 1.5 \text{ mm}^3$ glass epoxy board.

Caution 1) Absolute maximum ratings represent the value which cannot be exceeded for any length of time.

Caution 2) Even when the device is used within the range of absolute maximum ratings, as a result of continuous usage under high temperature, high current, high voltage, or drastic temperature change, the reliability of the IC may be degraded. Please contact us for the further details.

Stresses exceeding Maximum Ratings may damage the device. Maximum Ratings are stress ratings only. Functional operation above the Recommended Operating Conditions is not implied. Extended exposure to stresses above the Recommended Operating Conditions may affect device reliability.

Recommended Operating Conditions at $T_a = 25^\circ\text{C}$

Parameter	Symbol	Conditions	Ratings			Unit
			min	typ	max	
Supply voltage	V_{CC}		2.5		9.0	V
	V_S		1.8		9.0	V
Input "H"-level voltage	V_{IH}		1.8		9.0	V
Input "L"-level voltage	V_{IL}		-0.3		+0.7	V

LB1836M Application Note

Electrical Characteristics at $T_a = 25^\circ\text{C}$, $V_{CC} = V_S = 3\text{V}$

Parameter	Symbol	Conditions	Ratings			Unit
			min	typ	max	
Supply current	I_{CC0}	$V_{IN1, 2, 3, 4} = 0\text{V}$, $I_{CC} + I_S$		0.1	10	μA
	I_{CC1}	$V_{IN1} = 3\text{V}$, $V_{IN2, 3, 4} = 0\text{V}$, $I_{CC} + I_S$		14	20	mA
	I_{CC2}	$V_{IN1, 2} = 3\text{V}$, $V_{IN3, 4} = 0\text{V}$, $I_{CC} + I_S$		22	35	mA
Output saturation voltage (upper + lower)	V_{OUT1}	$I_{OUT} = 200\text{mA}$		0.20	0.28	V
	V_{OUT2}	$I_{OUT} = 400\text{mA}$		0.40	0.60	V
	V_{OUT3}	$I_{OUT} = 400\text{mA}$, Parallel connection		0.25	0.35	V
	V_{OUT4}	$I_{OUT} = 800\text{mA}$, Parallel connection		0.50	0.70	V
Output sustain voltage	V_O (SUS)	$I_{OUT} = 400\text{mA}$	9			V
Input current	I_{IN}	$V_{IN} = 2\text{V}$, $V_{CC} = 6\text{V}$			80	μA
Spark killer diode						
Reverse current	I_S (leak)	$V_{CC1, 2} = 9\text{V}$			30	μA
Forward voltage	V_{SF}	$I_{OUT} = 400\text{mA}$			1.7	V

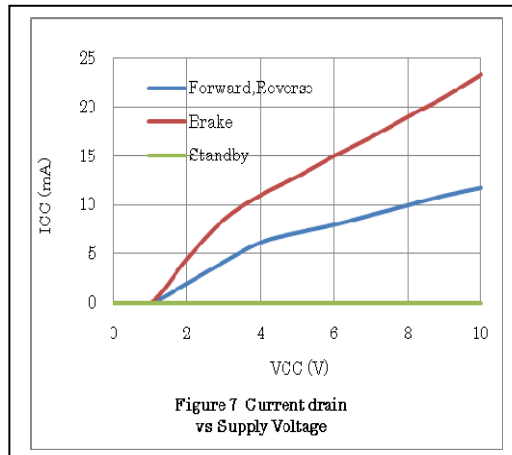
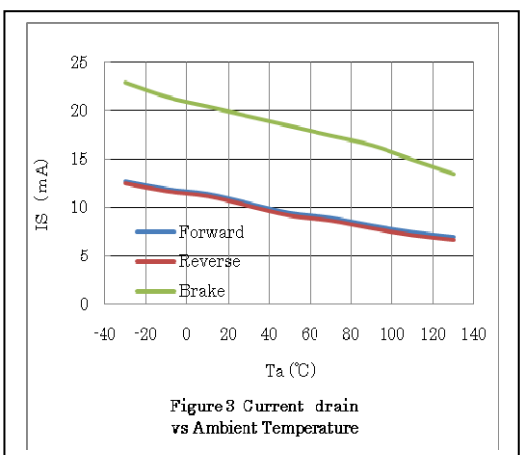
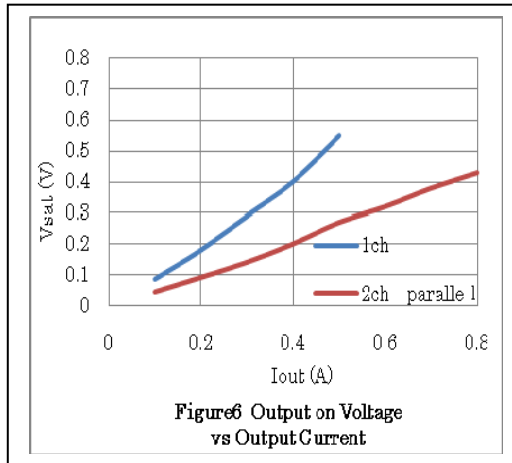
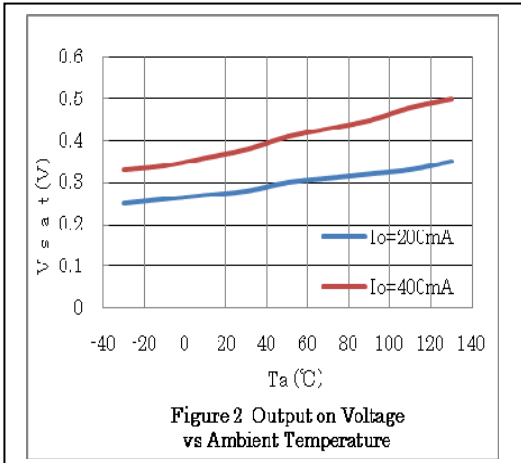
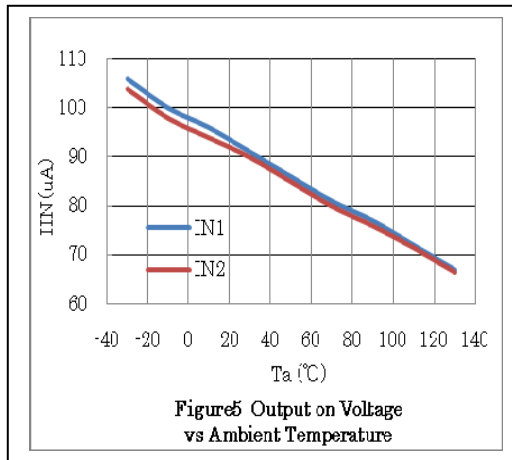
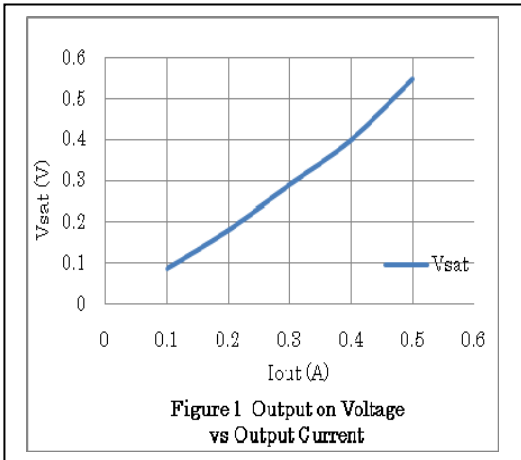

LB1836M Application Note

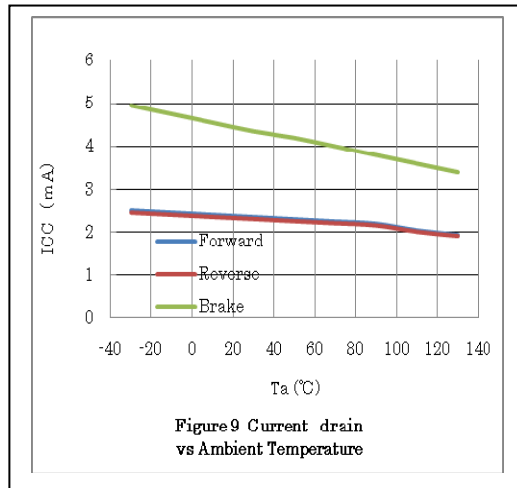
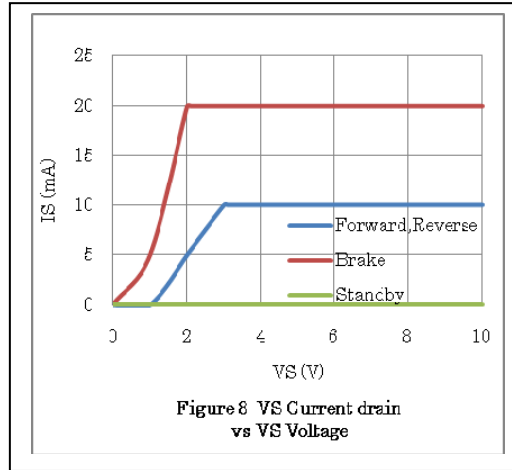
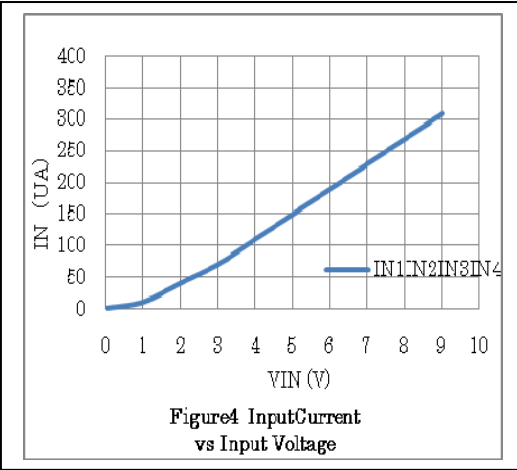

LB1836M Application Note

Pin function

Pin No.	Pin name	Pin function	Equivalent Circuit
1	VCC	Power-supply voltage pin. V _{CC} voltage is impressed. The permissible operation voltage is from 2.5 to 9.0(V). The capacitor is connected for stabilization for GND pin (7pin, 14pin).	
4 11	VS1 VS2	Power-supply voltage pin. (motor supply voltage) The permissible operation voltage is from 2.5 to 9.0(V). The capacitor is connected for stabilization for GND pin (7pin, 14pin).	
2	IN1	Motor drive control input pin. Driving control input pin of OUT1 (3pin) and OUT2 (5pin). It combines with IN2 pin (6pin) and it fights desperately. The digital input it, range of the "L" level input is 0 to 0.7(V), range of the "H" level input is from 1.8 to 9.0(V). PWM can be input. Pull-down resistance 30(kΩ) is built into in the pin. It becomes a standby mode because all IN1, IN2, IN3, and IN4 pins are made "L", and the circuit current can be adjusted to 0.	
6	IN2	Motor drive control input pin. Driving control input pin of OUT1 (3pin) and OUT2 (5pin). It combines with IN1 pin (2pin) and it uses it. PWM can be input. With built-in pull-down resistance.	
13	IN3	Motor drive control input pin. Driving control input pin of OUT3 (12pin) and OUT4 (10pin). It combines with IN4 pin (9pin) and it uses it. PWM can be input. With built-in pull-down resistance.	
9	IN4	Motor drive control input pin. Driving control input pin of OUT3 (12pin) and OUT4 (10pin). It combines with IN3 pin (13pin) and it uses it. PWM can be input. With built-in pull-down resistance.	
4,14	GND	Ground pin.	
8	Vcont	Pre-drive monitor terminal. Please refer to Vcontpin explanation.	
10	OUT4	Driving output pin. The motor coil is connected between terminal OUT3 (12pin).	
12	OUT3	Driving output pin. The motor coil is connected between terminal OUT4 (10pin).	
5	OUT2	Driving output pin. The motor coil is connected between terminal OUT1 (3pin).	
3	OUT1	Driving output pin. The motor coil is connected between terminal OUT2 (5pin).	

LB1836M Application Note

Operation explanation

1. LB1836M Input-Output-Logic

Truth Table

IN1/3	IN2/4	OUT1/3	OUT2/4	Mode
H	L	H	L	Forward
L	H	L	H	Reverse
H	H	L	L	Brake
L	L	OFF	OFF	Standby

2. DC motor operation sequence

- The following table shows the example of DC-motor sequence from Standby, Forward, Reverse, Brake, and Forward mode.

When IN1, IN2, IN3, IN4 are "L", the operation of this IC is stopped.

Please put standby mode for 10usec between Forward and Reverse mode.

Likewise, please put standby mode for 10usec between Forward and Brake mode, as well as Reverse and Brake mode.

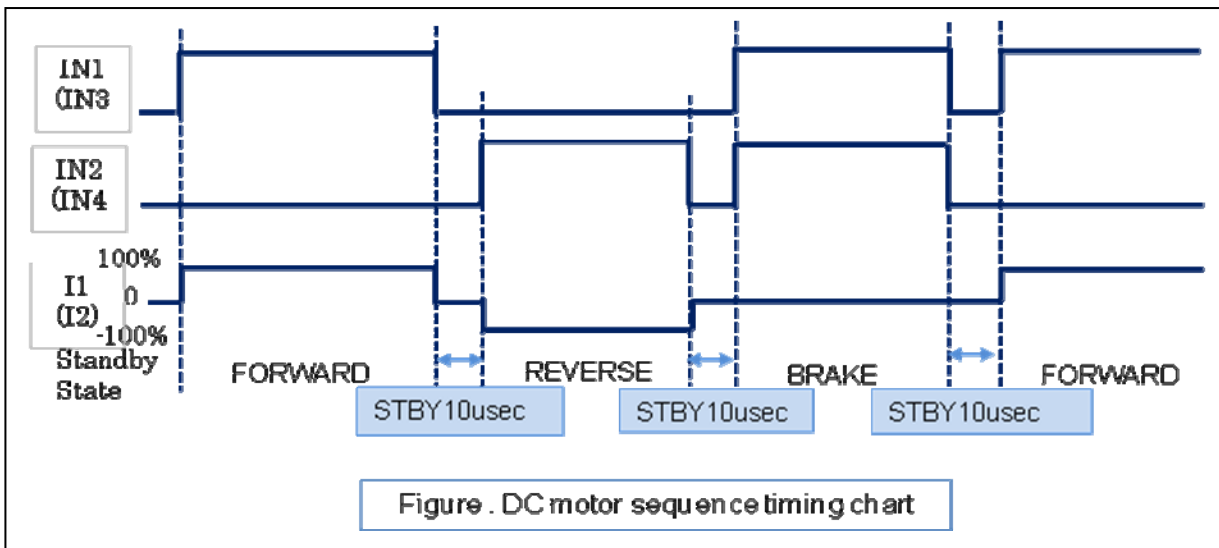

3. Stepping motor operation sequence

Example of current wave type in each excitation mode when stepping motor parallel input is controlled.

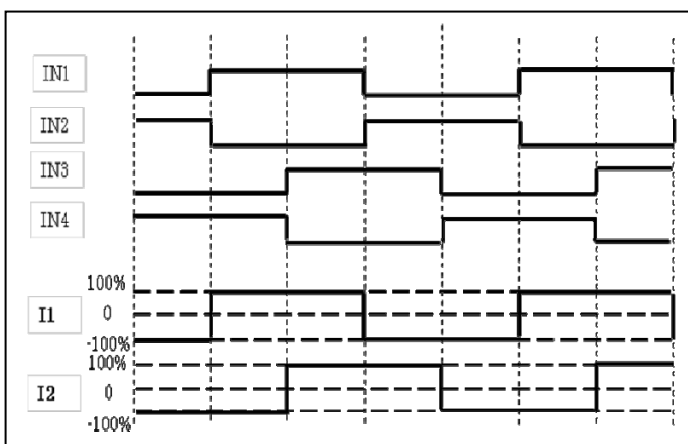

2 phase excitation

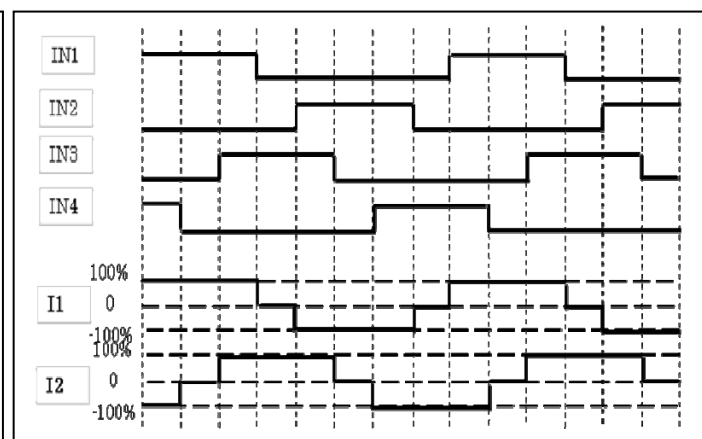

1-2 phase excitation

LB1836M Application Note

4. Theory

- Full-Step MODE

The motor moves 90 degrees in an electric corner when I input 1Step.

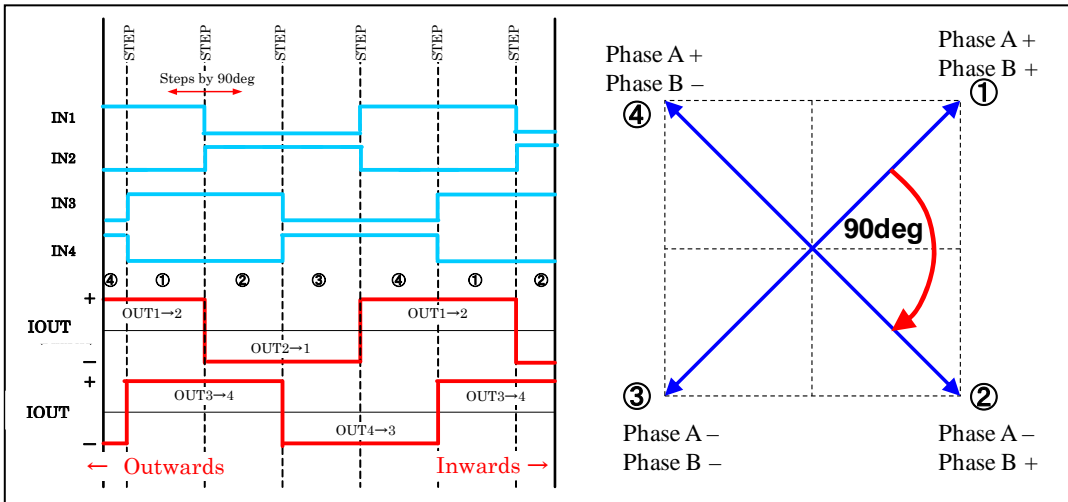

- Half-Step MODE

The motor moves 45 degrees in an electric corner when I input 1Step

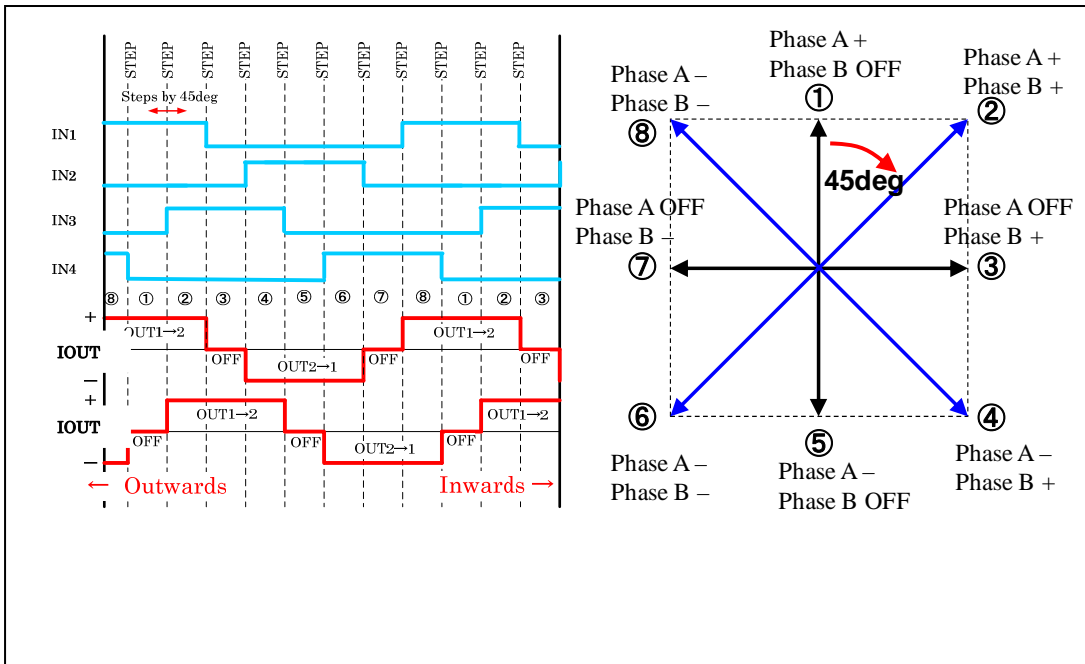

LB1836M Application Note

Design Notes

If large current flows on the power supply (V_S) line and the GND line, then in some applications and layouts, misoperation due to line oscillation may result.

The modes during which large current flows are as follows:

- Motor surge current when the DC motor starts up or when it shifts rotation directions (forward \leftrightarrow reverse).
- Passthrough current generated within the IC when shifting rotation directions (forward \leftrightarrow reverse) or when shifting from forward/reverse rotation to braking, or vice versa.

The following points should be kept in mind regarding the pattern layout :

- Keep the wiring lines thick and short in order to reduce wiring inductance between the power supply (V_S) and GND.
- Insert a passthrough capacitor near the IC. (Maximum effect is obtained by inserting the passthrough capacitor between V_S and the pin 7 GND at the closest distance possible.
- If the CPU and the LB1836M are mounted on separate boards and the difference between the ground potential of each board is large, install resistors of about 10k Ω in series between the CPU and the LB1836M inputs.

5. V_{cont} pin

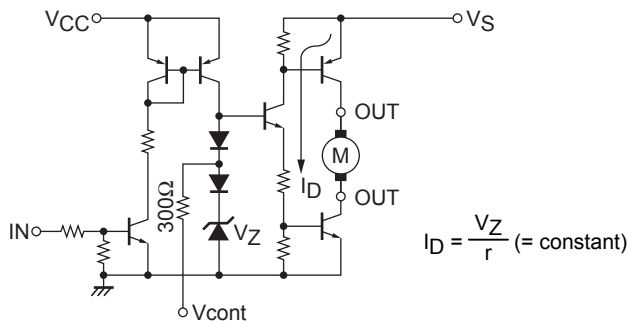

As shown in the above diagram, the V_{cont} pin outputs the voltage of the band gap Zener $V_Z + V_F$ ($=1.93V$). In normal use, this pin is left open.

The drive current I_D is varied by the V_{cont} voltage. However, because the band gap Zener is shared, it functions as a bridge.

The motor can stop by making v_{cont} terminal GND in emergency.

6. Thermal Shutdown circuit

The thermal shutdown circuit is incorporated and the output is turned off when junction temperature T_j exceeds 180°C and the abnormal state warning output is turned on. As the temperature falls by hysteresis, the output turned on again (automatic restoration).

The thermal shutdown circuit does not guarantee the protection of the final product because it operates when the temperature exceed the junction temperature of $T_{jmax}=150^\circ C$.

$$TSD = 180^\circ C \text{ (typ)}$$

$$\Delta TSD = 40^\circ C \text{ (typ)}$$

Application Circuit Example

1. Example of applied circuit with two DC motor driving

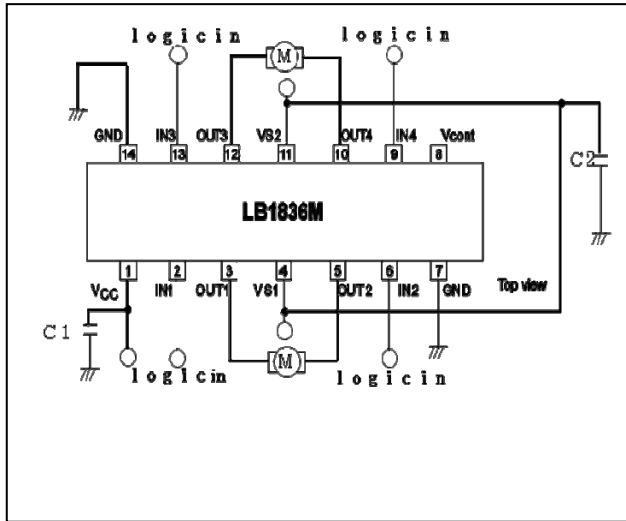

2. Example of applied circuit with one stepping motor driving

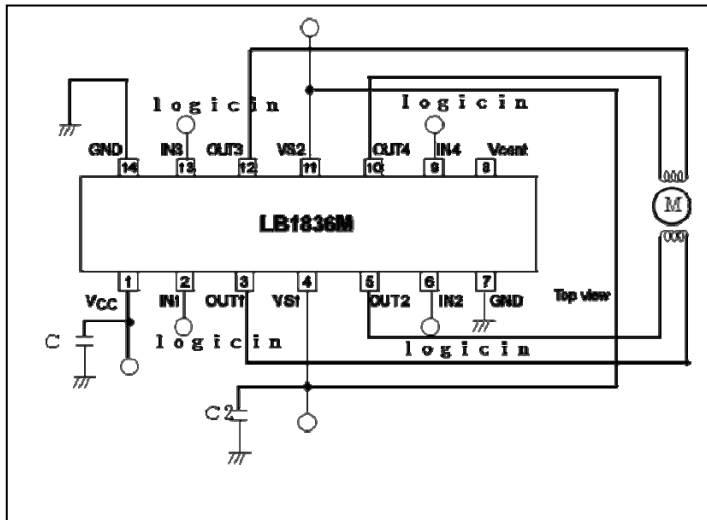

3. Example of applied circuit when connecting it in parallel

The use likened to H bridge 1ch is shown possible in the figure below by connecting IN1 with IN3, IN2 with IN4, OUT1 with OUT3, OUT2, and OUT4. ($I_O \text{ max}=2.0\text{A}$, Upper and lower total $R_{ON}=0.5\Omega$)

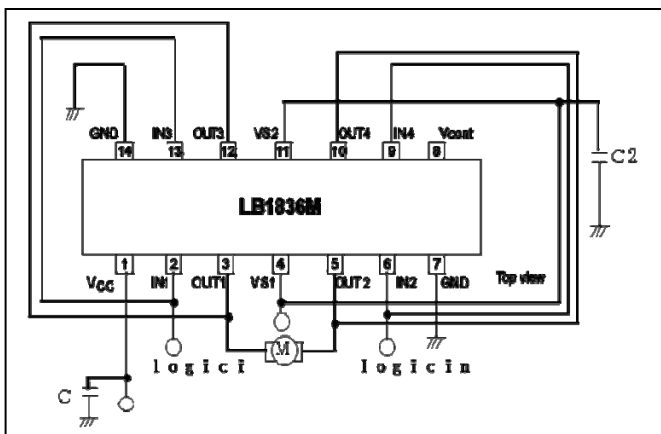

LB1836M Application Note

Eva-Board Manual

1. Eva-Board circuit diagram

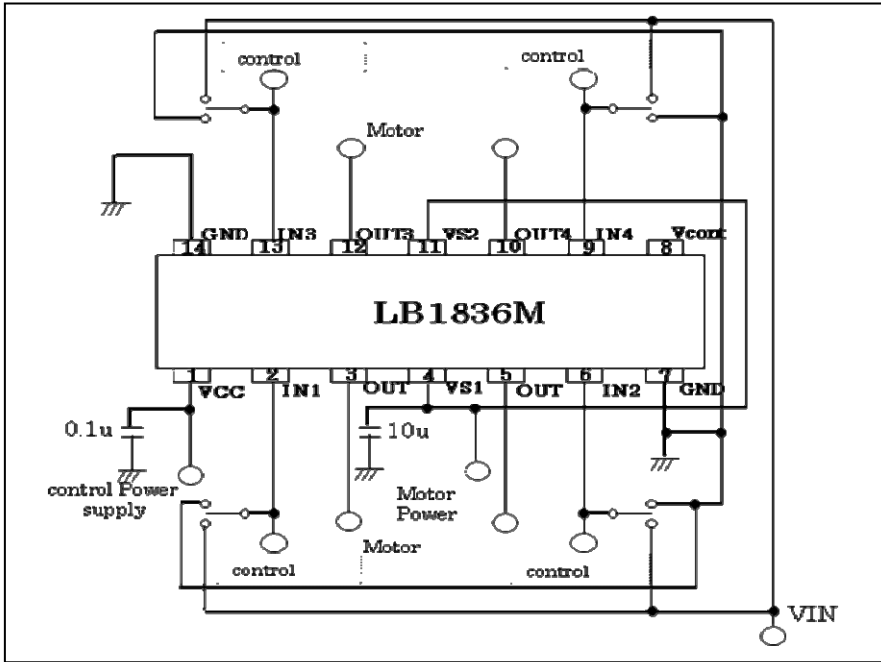

Bill of Materials for LB1836M Evaluation Board

Designator	Qty	Description	Value	Tol	Footprint	Manufacturer	Manufacturer Part Number	Substitution Allowed	Lead Free
IC1	1	Motor Driver			MFP14S (225mil)	ON semiconductor	LB1836M	No	Yes
C1	1	VCC Bypass capacitor	1 μ F 50V			KOA	GRM188B11A 105K	Yes	Yes
C2	1	Vs Bypass capacitor	0.1u 100v			Murata	GRM188R72A 104KA35D	Yes	Yes
SW1-SW4	4	Switch				MIYAMA	MS-621-A01	Yes	Yes
TP1-TP11	14	Test points				MAC8	ST-1-3	Yes	Yes

LB1836M Application Note

2. (1) Two DC motor drive

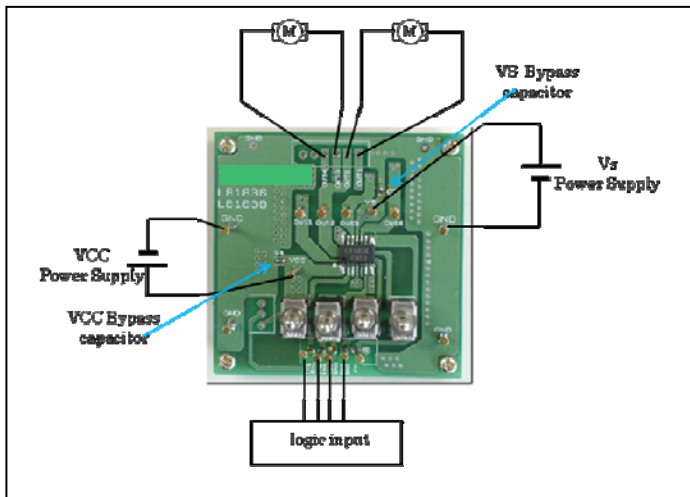

- Connect OUT1 and OUT2, OUT3 and OUT4 to a DC motor each.
- Connect the motor power supply with the terminal VCC, the control power supply with the terminal VIN. Connect the GND line with the terminal GND.
- DC motor becomes the predetermined output state corresponding to the input state by inputting an input signal such as the following truth value table into IN1~IN4.

(2) One stepping motor drive

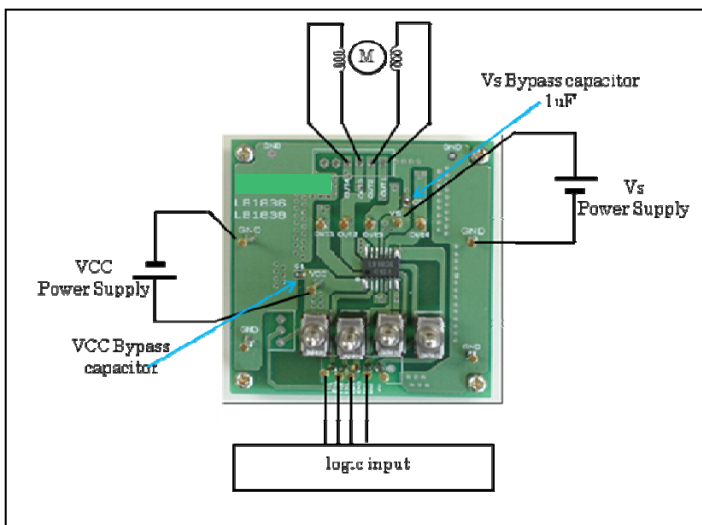

- Connect a stepping motor with OUT1, OUT2, OUT3 and OUT4.
- Connect the motor power supply with the terminal VCC, the control power supply with the terminal VIN. Connect the GND line with the terminal GND.
- STP motor drives it in an 2 phase excitation, 1-2 phase excitation by inputting an input signal such as follows into IN1~IN4.

LB1836M Application Note

Waveform of LB1836M evaluation board when driving stepping motor

- Full-Step Drive VCC=5V, VS=5V 1000pps

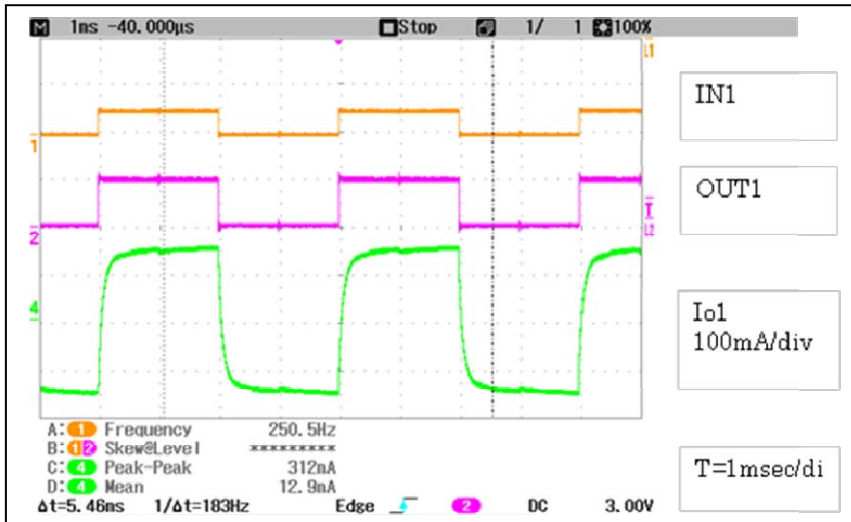

- Half-Step Drive VCC=5V, VS=5V 1600pps

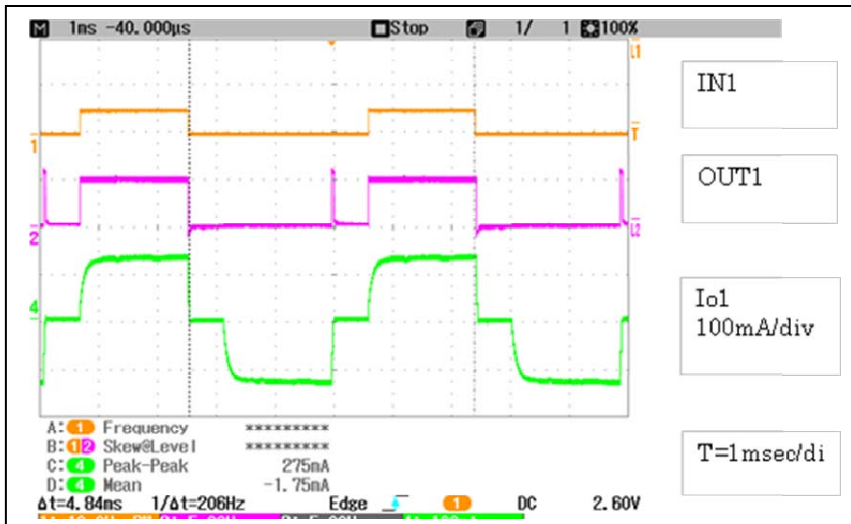



LB1836M Application Note

ON Semiconductor and the ON logo are registered trademarks of Semiconductor Components Industries, LLC (SCILLC). SCILLC owns the rights to a number of patents, trademarks, copyrights, trade secrets, and other intellectual property. A listing of SCILLC's product/patent coverage may be accessed at www.onsemi.com/site/pdf/Patent-Marking.pdf. SCILLC reserves the right to make changes without further notice to any products herein. SCILLC makes no warranty, representation or guarantee regarding the suitability of its products for any particular purpose, nor does SCILLC assume any liability arising out of the application or use of any product or circuit, and specifically disclaims any and all liability, including without limitation special, consequential or incidental damages. "Typical" parameters which may be provided in SCILLC data sheets and/or specifications can and do vary in different applications and actual performance may vary over time. All operating parameters, including "Typicals" must be validated for each customer application by customer's technical experts. SCILLC does not convey any license under its patent rights nor the rights of others. SCILLC products are not designed, intended, or authorized for use as components in systems intended for surgical implant into the body, or other applications intended to support or sustain life, or for any other application in which the failure of the SCILLC product could create a situation where personal injury or death may occur. Should Buyer purchase or use SCILLC products for any such unintended or unauthorized application, Buyer shall indemnify and hold SCILLC and its officers, employees, subsidiaries, affiliates, and distributors harmless against all claims, costs, damages, and expenses, and reasonable attorney fees arising out of, directly or indirectly, any claim of personal injury or death associated with such unintended or unauthorized use, even if such claim alleges that SCILLC was negligent regarding the design or manufacture of the part. SCILLC is an Equal Opportunity/Affirmative Action Employer. This literature is subject to all applicable copyright laws and is not for resale in any manner.

Looking for pricing, stock, or lifecycle information?

Click below to explore more details on WIN SOURCE:

-  [View LB1836M-TLM-E on WIN SOURCE](#)
-  [ON Semiconductor](#) Information

Optimize Your Supply Chain with WIN SOURCE Solutions

-  Global Sourcing Solution
-  Obsolete Management
-  Cost Control Management
-  Shortage Management
-  Alternative Solution
-  Excess Inventory Management