



**THE DATASHEET OF
LB11961-MPB-H**



LB11961

Single-Phase Full-Wave Fan Motor Driver

Overview

The LB11961 is a single-phase bipolar drive motor driver that easily implements direct PWM motor drive systems with excellent efficiency. The LB11961 is optimal for fan motor drive in personal computer power supply systems and CPU cooling fan systems.

Features

- Single-phase full-wave drive (16V, 1.0A transistors are built in)
- Built-in variable speed function controlled by a thermistor input
The LB11961 can implement quiet, low-vibration variable speed control using externally clocked high side transistor direct PWM drive.
- Built-in regenerative diode (Di); only requires a minimal number of external components.
- Built-in HB
- Minimum speed setting pin (allows full-speed mode operation at startup)
- Operates in full-speed mode when the thermistor is removed.
- Built-in lock protection and automatic recovery circuits
- FG (speed detection) and RD (lock detection) outputs
- Built-in thermal shutdown circuit

Applications

- Personal computer power supply systems
- CPU cooling fan systems

Specifications

Absolute Maximum Ratings at $T_a = 25^\circ\text{C}$ (Note1)

Parameter	Symbol	Conditions	Ratings	Unit
V_{CC} maximum output voltage	$V_{CC\ max}$		18	V
OUT pin maximum output current	$I_{OUT\ max}$		1.0	A
OUT pin output voltage	$V_{OUT\ max}$		18	V
HB maximum output current	$I_{HB\ max}$		10	mA
VTH input pin voltage	$V_{TH\ max}$		6	V
RD/FG output pin output voltage	$V_{RD/FG\ max}$		18	V
RD/FG output current	$I_{RD/FG}$		10	mA
Allowable power dissipation	$P_d\ max$	When mounted on a circuit board (Note2)	1.1	W
Operating temperature	T_{opr}		-30 to +90	$^\circ\text{C}$
Storage temperature	T_{stg}		-55 to +150	$^\circ\text{C}$

1. Stresses exceeding those listed in the Maximum Rating table may damage the device. If any of these limits are exceeded, device functionality should not be assumed, damage may occur and reliability may be affected.
2. Specified circuit board : $114.3 \times 76.1 \times 1.6\text{mm}^3$, glass epoxy.



ON Semiconductor[®]

www.onsemi.com

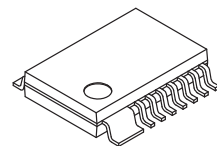

HSSOP14 (225mil)

GENERIC MARKING DIAGRAM*

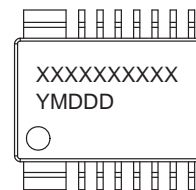

XXXXX = Specific Device Code
Y = Year
M = Month
DDD = Additional Traceability Data

ORDERING INFORMATION

See detailed ordering and shipping information on page 8 of this data sheet.

LB11961

Recommended Operating Conditions at Ta = 25°C (Note3)

Parameter	Symbol	Conditions	Ratings	Unit
V _{CC} supply voltage	V _{CC}		4.5 to 16	V
V _{TH} input level voltage range	V _{TH}		0 to 9	V
Hall sensor input common-mode input voltage range	V _{ICM}		0.2 to 3	V

3. Functional operation above the stresses listed in the Recommended Operating Ranges is not implied. Extended exposure to stresses beyond the Recommended Operating Ranges limits may affect device reliability.

Electrical Characteristics Unless otherwise specified Ta = 25°C, V_{CC} = 12V (Note4)

Parameter	Symbol	Conditions	Ratings			Unit
			min	typ	max	
Circuit current	I _{CC1}	Drive mode	12	18	24	mA
	I _{CC2}	Lock protection mode	8	11	16	mA
6VREG voltage	V _{6VREG}	I _{6VREG} = 5mA	5.8	6	6.2	V
HB voltage	V _{HB}	I _{HB} = 5mA	1.10	1.25	1.40	V
CPWM high-level voltage	V _{CRH}		3.45	3.6	3.75	V
CPWM low-level voltage	V _{CRL}		1.95	2.05	2.15	V
CPWM oscillator frequency	FPWM	C = 100pF	18	25	32	kHz
CT pin high-level voltage	V _{CTH}		3.45	3.6	3.75	V
CT pin low-level voltage	V _{CTL}		1.55	1.7	1.85	V
ICT charge current	I _{CT1}		1.5	2	2.5	μA
ICT discharge current	I _{CT2}		0.15	0.2	0.25	μA
ICT charge/discharge current ratio	R _{CT}		8.5	10	11.5	
OUT output low saturation voltage	V _{OL}	I _O = 200mA		0.2	0.3	V
OUT output high saturation voltage	V _{OH}	I _O = 200mA		0.9	1.1	V
Hall sensor input sensitivity	V _{HN}	Zero peak value (including offset and hysteresis)		10	20	mV
RD/FG output pin low-level voltage	VR _{DL} /F _{GL}	I _{RD/FG} = 5mA		0.2	0.3	V
RD/FG output pin leakage current	IR _{DL} /F _{GL}	VR _{DL} /F _{GL} = 7V			30	μA

4. Product parametric performance is indicated in the Electrical Characteristics for the listed test conditions, unless otherwise noted. Product performance may not be indicated by the Electrical Characteristics if operated under different conditions.

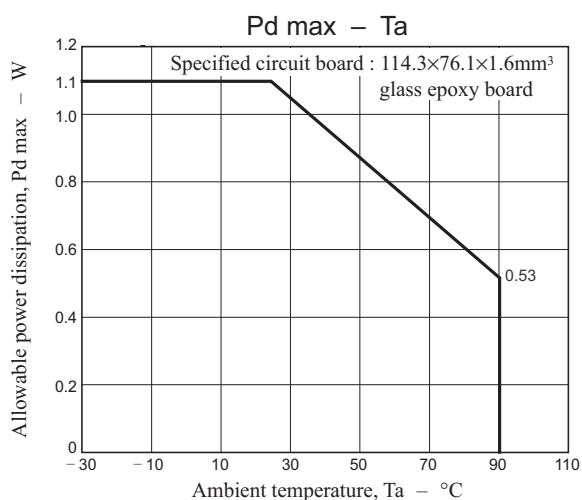

LB11961

Truth Table

VTH	IN-	IN+	CPWM	CT	OUT1	OUT2	FG	RD	Mode	
Low (open)	High	Low	High	Low	High	Low	Low	On	During rotation – drive (PWM off)	
	Low	High			Low	High	Off			
High	High	Low	Low		Off	Low	Low		Off	During rotation – regeneration (PWM on)
	Low	High			Low	Off	Off			
-	High	Low	-	High	High	Off	Low	Off	Lock protection	
-	Low	High			Off	High	Off			

CPWM – High is the state where CPWM > VTH, and CPWM– Low is the state where CPWM < VTH.

Open : The LB11961 operates in full-speed mode when the thermistor is removed.

Pin Assignment

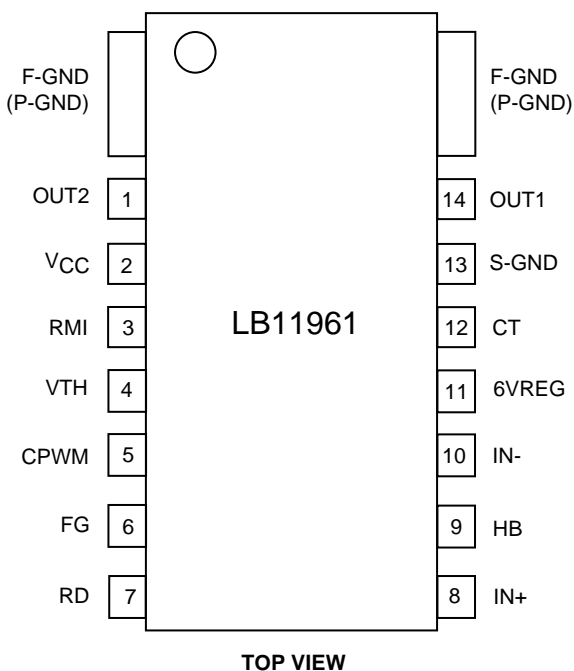

F-GND (P-GND) : The motor system ground and the heat sink. Since the heat generated by the chip is dissipated through F-GND, the thermal resistance is lowered by increasing the area of the copper foil and solder surface in the printed circuit pattern.

S-GND : Control system ground

LB11961

Block Diagram

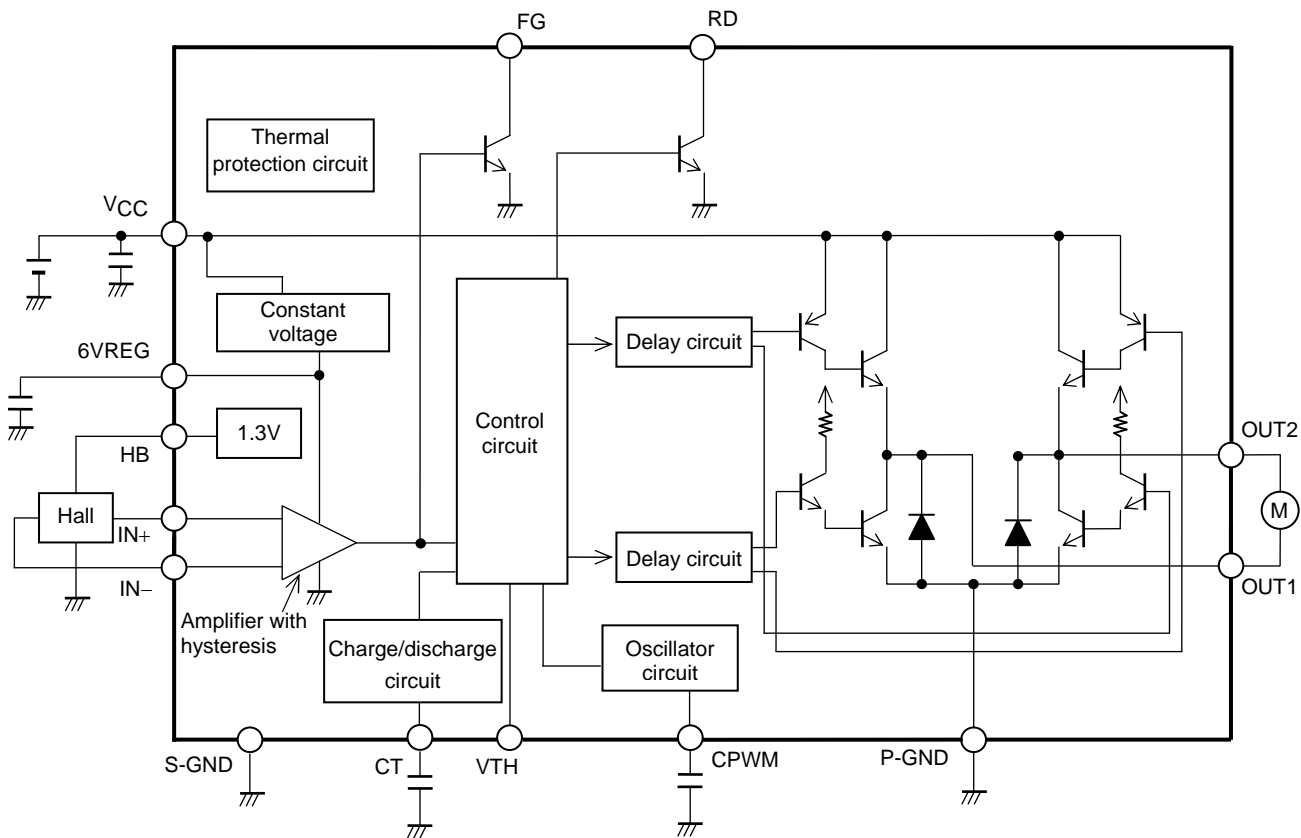

LB11961

*6. FG output

This is an open collector output, and a rotation count detection function can be implemented using this FG output, which corresponds to the phase switching. This pin must be left open if unused.

*7. HB pin

This pin provides a Hall effect sensor bias constant-voltage output of 1.25V.

*8. RMI pin

Connect this pin to VTH if unused. Even if unused, the IC is set internally to operate at a 10% drive duty at the voltage corresponding to the lowest speed. (The capacitor is used to set up full-speed mode at startup.)

Control Timing Chart

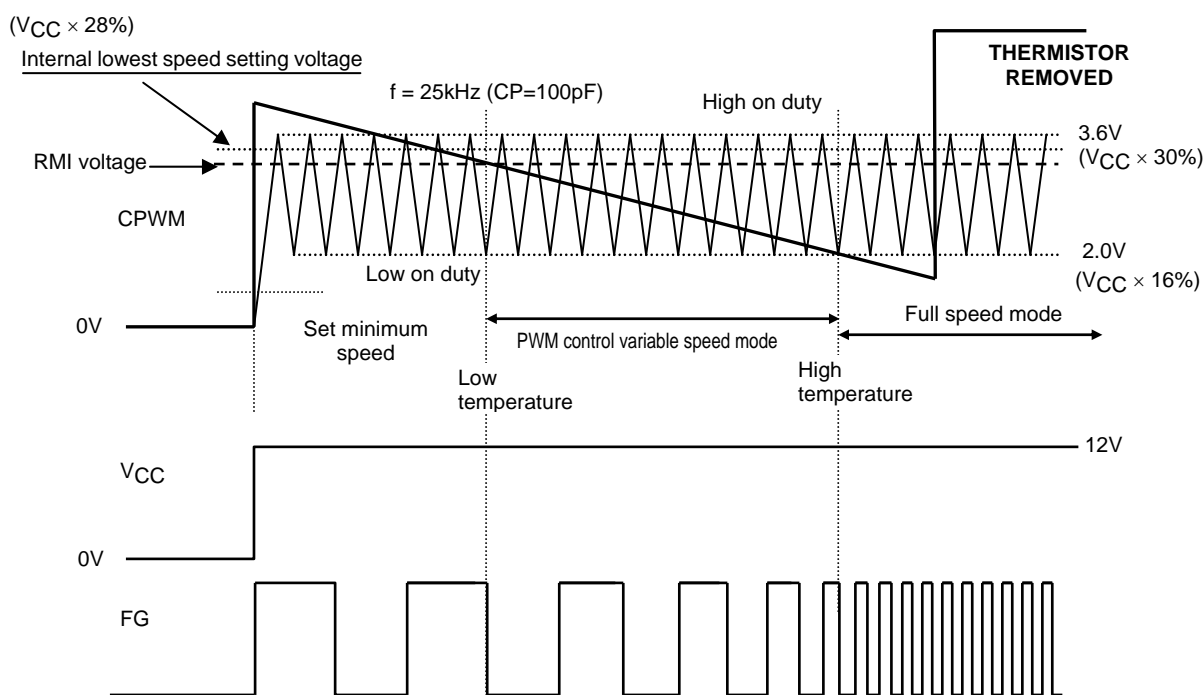

1. Set minimum speed mode

A VTH voltage level is generated when the thermistor detects the set temperature. At low temperatures, the fan motor turns at the lowest speed, which is set with the RMI pin. The LB11961 compares the CPWM oscillator voltage with the RMI pin voltage and sets the duty for the lowest drive state.

2. High speed ↔ low speed mode

The PWM signal is controlled by comparing the CPWM oscillation voltage that cycles between 1.2V and 3.8V and the VTH voltage.

When the VTH voltage is lower, the high and low side transistors are turned on, and when the VTH voltage is higher, the high side transistor is turned off and the coil current is regenerated through the low side transistor. Thus the output on duty increases as the VTH voltage becomes lower, the coil current increases, and the motor speed increases.

Rotation speed feedback is provided by the FG output.

3. Full-speed mode

The LB11961 switches to full-speed mode above a certain temperature.

4. Thermistor removed mode

If the thermistor is removed, the VTH input voltage will rise. However, the output will go to full drive at 100% and the motor will run at full speed.

LB11961

ORDERING INFORMATION



Device	Package	Wire Bond	Shipping(Qty/Packing)
LB11961-MPB-H	HSSOP14(225mil) (Pb-Free / Halogen Free)	Au-wire	70 / Fan-fold
LB11961-TLM-H	HSSOP14(225mil) (Pb-Free / Halogen Free)	Au-wire	2000 / Tape & Reel
LB11961-W-AH	HSSOP14(225mil) (Pb-Free / Halogen Free)	Cu-wire	2000 / Tape & Reel

† For information on tape and reel specifications, including part orientation and tape sizes, please refer to our Tape and Reel Packaging Specifications Brochure, BRD8011/D. http://www.onsemi.com/pub_link/Collateral/BRD8011-D.PDF

ON Semiconductor and the ON Semiconductor logo are trademarks of Semiconductor Components Industries, LLC dba ON Semiconductor or its subsidiaries in the United States and/or other countries. ON Semiconductor owns the rights to a number of patents, trademarks, copyrights, trade secrets, and other intellectual property. A listing of ON Semiconductor's product/patent coverage may be accessed at www.onsemi.com/site/pdf/Patent-Marking.pdf. ON Semiconductor reserves the right to make changes without further notice to any products herein. ON Semiconductor makes no warranty, representation or guarantee regarding the suitability of its products for any particular purpose, nor does ON Semiconductor assume any liability arising out of the application or use of any product or circuit, and specifically disclaims any and all liability, including without limitation special, consequential or incidental damages. Buyer is responsible for its products and applications using ON Semiconductor products, including compliance with all laws, regulations and safety requirements or standards, regardless of any support or applications information provided by ON Semiconductor. "Typical" parameters which may be provided in ON Semiconductor data sheets and/or specifications can and do vary in different applications and actual performance may vary over time. All operating parameters, including "Typicals" must be validated for each customer application by customer's technical experts. ON Semiconductor does not convey any license under its patent rights nor the rights of others. ON Semiconductor products are not designed, intended, or authorized for use as a critical component in life support systems or any FDA Class 3 medical devices or medical devices with a same or similar classification in a foreign jurisdiction or any devices intended for implantation in the human body. Should Buyer purchase or use ON Semiconductor products for any such unintended or unauthorized application, Buyer shall indemnify and hold ON Semiconductor and its officers, employees, subsidiaries, affiliates, and distributors harmless against all claims, costs, damages, and expenses, and reasonable attorney fees arising out of, directly or indirectly, any claim of personal injury or death associated with such unintended or unauthorized use, even if such claim alleges that ON Semiconductor was negligent regarding the design or manufacture of the part. ON Semiconductor is an Equal Opportunity/Affirmative Action Employer. This literature is subject to all applicable copyright laws and is not for resale in any manner.

Looking for pricing, stock, or lifecycle information?

Click below to explore more details on WIN SOURCE:

-  [View LB11961-MPB-H on WIN SOURCE](#)
-  [ON Semiconductor](#) Information

Optimize Your Supply Chain with WIN SOURCE Solutions

-  Global Sourcing Solution
-  Obsolete Management
-  Cost Control Management
-  Shortage Management
-  Alternative Solution
-  Excess Inventory Management