

# LB11660FV

Monolithic Digital IC

## Half-pre Motor Driver Single-Phase Full-Wave, for Fan Motor



**ON Semiconductor**<sup>®</sup>

[www.onsemi.com](http://www.onsemi.com)

### Overview

The LB11660FV is a single-phase bipolar drive half-predriver motor driver that can easily implement a direct PWM driver motor driver circuit with excellent efficiency. The LB11660FV is particularly well suited for the miniature fans used in servers.

### Features

- Single-phase full-wave drive (15V, 1.5A transistors are built in)  
Half predriver with integrated high side transistor
- Built-in variable speed function controlled by an external input  
The LB11660FV can implement quiet, low-vibration variable speed control using externally clocked high side transistor direct PWM drive.
- Minimum speed setting pin
- Current limiter circuit  
(The limit value is determined by  $R_f$ ;  $I_O = 1A$  when  $R_F = 0.5\Omega$ )
- Built-in kickback absorption circuit
- Soft switching circuit makes low current consumption, low loss, and low noise drive possible at phase switching
- Built-in HB
- Built-in lock protection and automatic recovery circuits  
(built-in on/off ratio switching circuit controlled by the supply voltage)
- FG (speed detection) output
- Built-in thermal protection circuit (design guarantee)

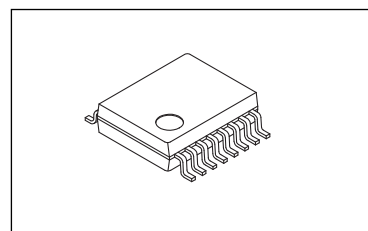

SSOP16 (225mil)

### ORDERING INFORMATION

See detailed ordering and shipping information on page 10 of this data sheet.

# LB11660FV

## Specifications

### Absolute Maximum Ratings at Ta = 25°C

Parameter	Symbol	Conditions	Ratings	Unit
V <sub>CC</sub> maximum supply voltage	V <sub>CC</sub> max		20	V
VM maximum supply voltage	VM max		20	V
OUT pin maximum output current	I <sub>OUT</sub> max	R <sub>f</sub> ≥ 0.39Ω	1.5	A
OUT pin output voltage 1	V <sub>OUT</sub> max 1		20	V
OUT pin output voltage 2	V <sub>OUT</sub> max 2	T ≤ 0.4μs	26.5	V
PRE pin maximum source current	IPSO max		30	mA
PRE pin maximum sink current	IPSI max		-7	mA
PRE pin output voltage	VP max		20	V
HB maximum output current	HB max		10	mA
VTH input pin voltage	VTH max		7	V
FG output pin voltage	VFG max		18	V
FG output current	IFG max		10	mA
Allowable power dissipation	Pd max	When mounted on a circuit board *1	0.8	W
Operating temperature	Topr	*2	-30 to +90	°C
Storage temperature	Tstg		-55 to +150	°C

\*1 Specified circuit board : 114.3 × 76.1 × 1.6mm<sup>3</sup>, glass epoxy.

\*2: T<sub>j</sub> max is 150°C. This device must be used under conditions such that the chip temperature does not exceed T<sub>j</sub> = 150°C during operation.

Stresses exceeding those listed in the Maximum Ratings table may damage the device. If any of these limits are exceeded, device functionality should not be assumed, damage may occur and reliability may be affected.

### Recommended Operating Conditions at Ta = 25°C

Parameter	Symbol	Conditions	Ratings	Unit
V <sub>CC</sub> supply voltage	V <sub>CC</sub>		4 to 15	V
V <sub>M</sub> supply voltage	VM		3 to 15	V
Current limiter operation range	ILIM		0.6 to 1.2	V
VTH input level voltage range	VTH		0 to 6	V
Hall sensor input common-mode input voltage range	VICM		0.2 to 3	V

Functional operation above the stresses listed in the Recommended Operating Ranges is not implied. Extended exposure to stresses beyond the Recommended Operating Ranges limits may affect device reliability.

# LB11660FV

## Electrical Characteristics Unless otherwise specified Ta = 25°C, V<sub>CC</sub> = 12V

Parameter	Symbol	Conditions	Ratings			Unit
			min	typ	max	
Circuit current	I <sub>CC1</sub>	Drive mode		9	12	mA
HB voltage	V <sub>HB</sub>	I <sub>HB</sub> = 5mA	1.05	1.25	1.40	V
6VREG voltage	V <sub>6VREG</sub>	6VREG = 5mA	5.80	6	6.20	V
CT pin high-level voltage	V <sub>CTH</sub>		3.4	3.6	3.8	V
CT pin low-level voltage	V <sub>CTL</sub>		1.4	1.6	1.8	V
ICT pin charge current 1	I <sub>CTC1</sub>	V <sub>CC</sub> = 12V	1.7	2.2	2.7	μA
ICT pin charge current 2	I <sub>CTC2</sub>	V <sub>CC</sub> = 6V	1.3	1.8	2.3	μA
ICT pin discharge current 1	I <sub>CTD1</sub>	V <sub>CC</sub> = 12V	0.11	0.15	0.19	μA
ICT pin discharge current 2	I <sub>CTD2</sub>	V <sub>CC</sub> = 6V	0.34	0.44	0.54	μA
ICT charge/discharge current ratio 1	R <sub>CT1</sub>	V <sub>CC</sub> = 12V	12	15	18	Times
ICT charge/discharge current ratio 2	R <sub>CT2</sub>	V <sub>CC</sub> = 6V	3	4	5	Times
ICT charge/discharge ratio threshold voltage	V <sub>RCT</sub>		6	6.6	7.3	V
VTH bias current	I <sub>BVTH</sub>		-2	-1	0	μA
OUT output high saturation voltage	V <sub>OH</sub>	I <sub>O</sub> = 200mA, R <sub>L</sub> = 1Ω		0.6	0.8	V
PRE output low saturation voltage	V <sub>PL</sub>	I <sub>O</sub> = 5mA		0.2	0.4	V
PRE output high saturation voltage	V <sub>PH</sub>	I <sub>O</sub> = -20mA		0.9	1.2	V
Current limiter	V <sub>Rf</sub>	V <sub>CC</sub> - V <sub>M</sub>	450	500	550	mV
PWM output pin high-level voltage	V <sub>PWMH</sub>		2.2	2.5	2.8	V
PWM output pin low-level voltage	V <sub>PWML</sub>		0.4	0.5	0.7	V
PWM external C charge current	I <sub>PWM1</sub>		-23	-18	-14	μA
PWM external C discharge current	I <sub>PWM2</sub>		18	24	30	μA
PWM oscillator frequency	F <sub>PWM</sub>	C = 200pF	19	23	27	kHz
Hall sensor input sensitivity	V <sub>HN</sub>	Zero peak value (including offset and hysteresis)		15	25	mV
FG output pin low-level voltage	V <sub>FG/RD</sub>	I <sub>FG/RD</sub> = 5mA		0.2	0.3	V
FG output pin leakage current	I <sub>FGL/IRDL</sub>	V <sub>FG/RD</sub> = 7V			30	μA
Thermal protection circuit	THD	Design target value*3	150	180	210	°C

\*3: This is a design guarantee and is not tested in individual units. The thermal protection circuit is included to prevent any thermal damage to the IC. Since this would imply operation outside the IC's guaranteed temperature range, the application thermal design must be such that the thermal protection circuit will not operate if the fan is operating constantly.

Product parametric performance is indicated in the Electrical Characteristics for the listed test conditions, unless otherwise noted. Product performance may not be indicated by the Electrical Characteristics if operated under different conditions.

# LB11660FV

## Package Dimensions

unit : mm

### SSOP16 (225mil)

CASE 565AM

ISSUE A

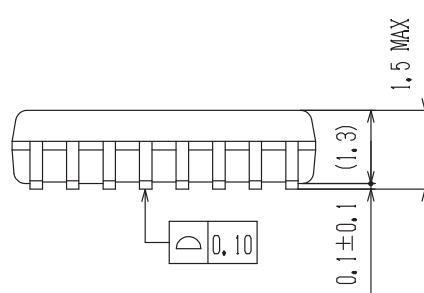
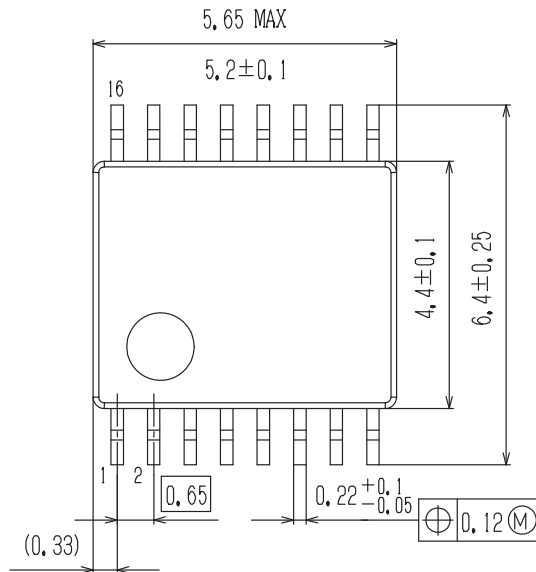

### SOLDERING FOOTPRINT\*

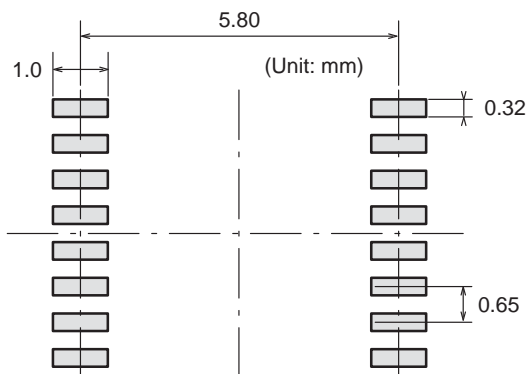

NOTE: The measurements are not to guarantee but for reference only.

\*For additional information on our Pb-Free strategy and soldering details, please download the ON Semiconductor Soldering and Mounting Techniques Reference Manual, SOLDERRM/D.

### GENERIC MARKING DIAGRAM\*

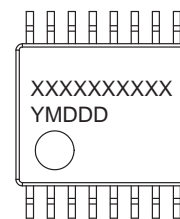

XXXXXX = Specific Device Code  
 Y = Year  
 M = Month  
 DDD = Additional Traceability Data

\*This information is generic. Please refer to device data sheet for actual part marking. Pb-Free indicator, "G" or microdot "•", may or may not be present.

# LB11660FV

## Pin Assignment

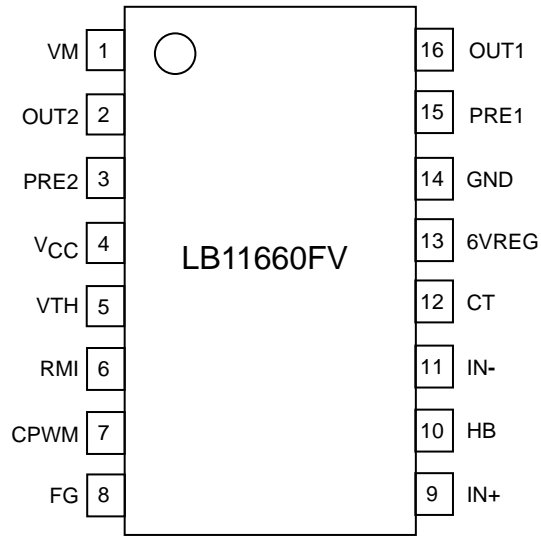

Top view

## Truth Table

IN-	IN+	VTH	CPWM	CT	OUT1	OUT2	PRE1	PRE2	FG	Mode
High	Low	Low	High	Low	High	Off	Low	High	Low	During rotation – drive
Low	High				Off	High	High	Low	Off	
High	Low	High	Low		Off	Off	Low	High	Low	During rotation – regeneration
Low	High				Off	Off	High	Low	Off	
High	Low	-	-	High	Off	Off	Low	High	Low	Lock protection
Low	High				Off	Off	High	Low	Off	

CPWM – High is the state where CPWM > VTH, and CPWM– Low is the state where CPWM < VTH.

# LB11660FV

## Application Circuit Example 1

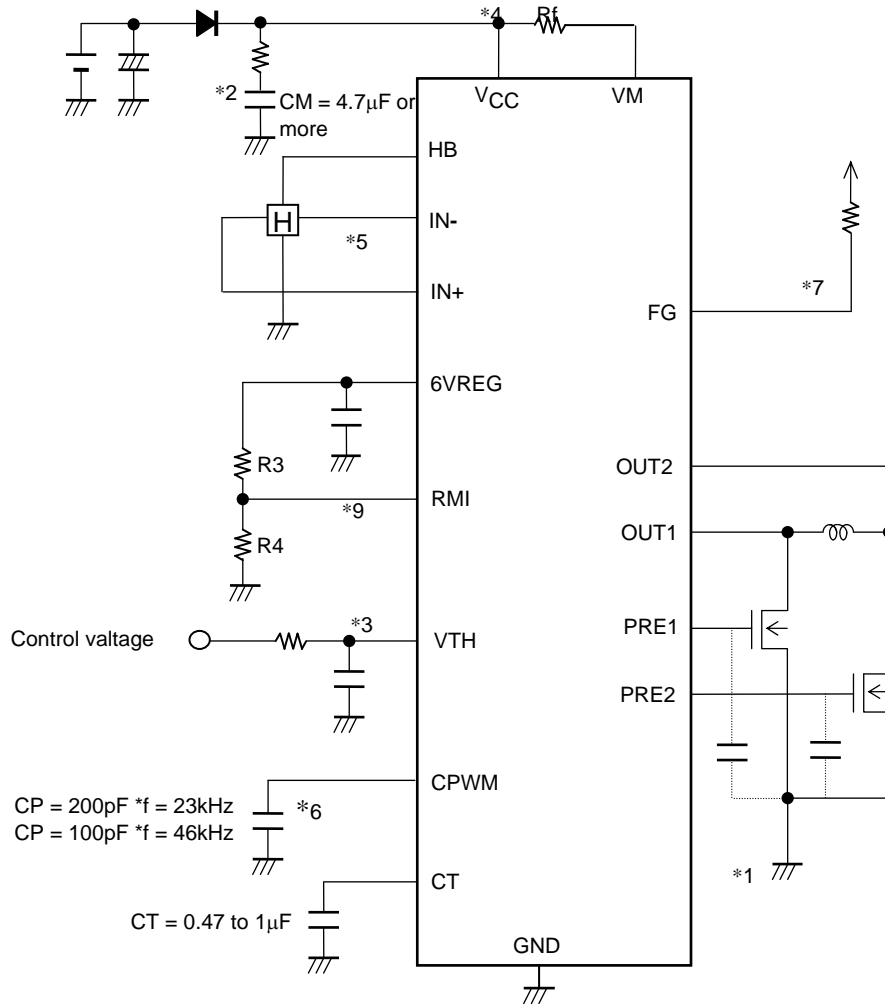

### \*1. Power supply and ground lines

The IC ground is the control current power supply system ground, and the external n-channel transistor ground is the motor power supply system ground.

These two systems should be formed from separate lines and the control system external components should be connected to the IC ground.

### \*2. Regeneration power supply stabilization capacitor

Use a 4.7 $\mu$ F/25V capacitor at least for CM, which is the power supply stabilization capacitor for both PWM drive and kickback absorption.

The capacitor CM must be connected to prevent destruction of the IC when power is applied or removed.

### \*3. Speed Control

#### (1) Control voltage

The PWM duty is determined by comparing the VTH pin voltage with the PWM oscillator waveform.

When the VTH voltage falls, the on duty increases and when the VTH voltage falls below the PWM output low level, the duty will go to 100%.

#### (2) Thermistor

For thermistor applications, normally the 6VREG level will be resistor divided and the divided level input to the VTH pin.

The PWM duty is changed by changes in the VTH pin voltage due to changes in temperature.

### \*4. Current limiter setting

The current limiter circuit operates if the voltage across the resistor between VCC and the VM pin exceeds 0.5V.

Since the current limiter circuit applies limitation at a current determined by  $I_O = VR_f/R_f$  (where  $VR_f = 0.5V$  (typical),  $R_f$ : resistance of the current detection resistor), the current limiter will operate at  $I_O = 1A$  when  $R_f = 0.5\Omega$ .

The resistor  $R_f$  must be connected in the circuit and it must have a value such that the circuit operates within the recommended current limiter operating range.

# LB11660FV

## \*5. Hall sensor input

Lines that are as short as possible must be used to prevent noise from entering the system. The Hall sensor input circuit consists of a comparator with hysteresis (20mV). We recommend that the Hall sensor input level be at least three times this hysteresis, i.e. at least 60mVp-p.

## \*6. PWM oscillator frequency setting capacitor

The PWM oscillator oscillates at  $f = 23\text{kHz}$  when CP is 200pF and at  $f = 46\text{kHz}$  when CP is 100pF, and this frequency becomes the PWM reference frequency.

Note that the PWM frequency is given approximately by the following equation.

$$f \text{ [kHz]} \approx (4.6 \times 10^6) \div C \text{ [pF]}$$

## \*7. FG output

This is an open collector output, and a rotation count detection function can be implemented using this FG output, which corresponds to the phase switching. This pin must be left open if unused.

## \*8. HB pin

This pin provides a Hall effect sensor bias constant-voltage output of 1.25V.

## \*9. RMI pin

This pin is the speed control minimum speed setting.

The minimum output duty is set by R3 and R4. Leave R4 open to have the motor stop when the duty is 0%.

## Rotation Control Timing Chart

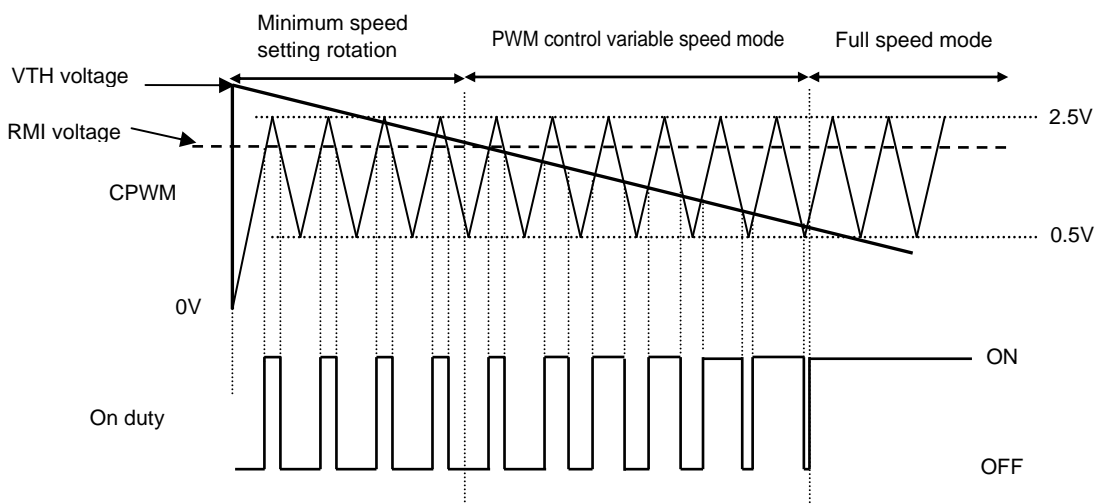
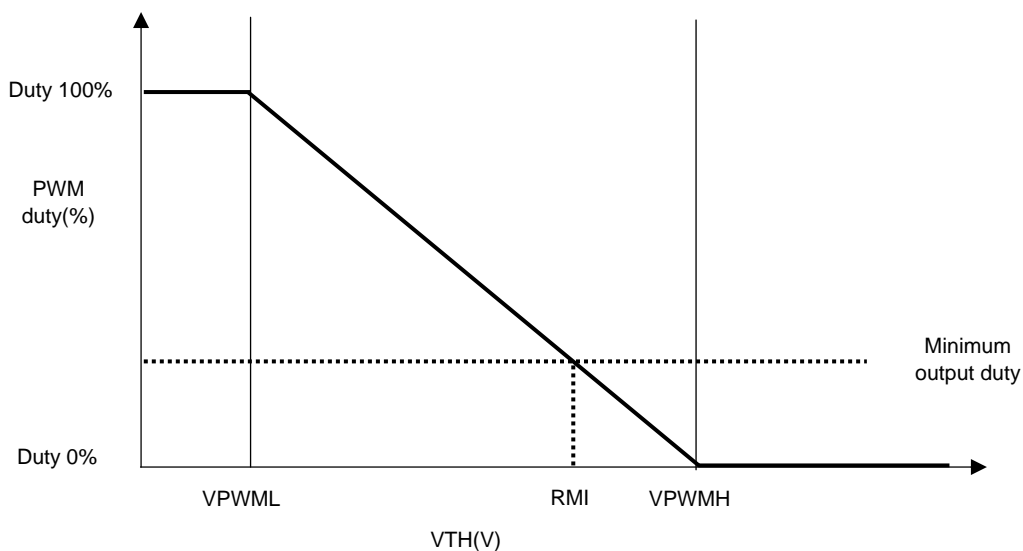

# LB11660FV

## Application Circuit Example 2

Mounting circuit board (Component values are provided for reference purposes)

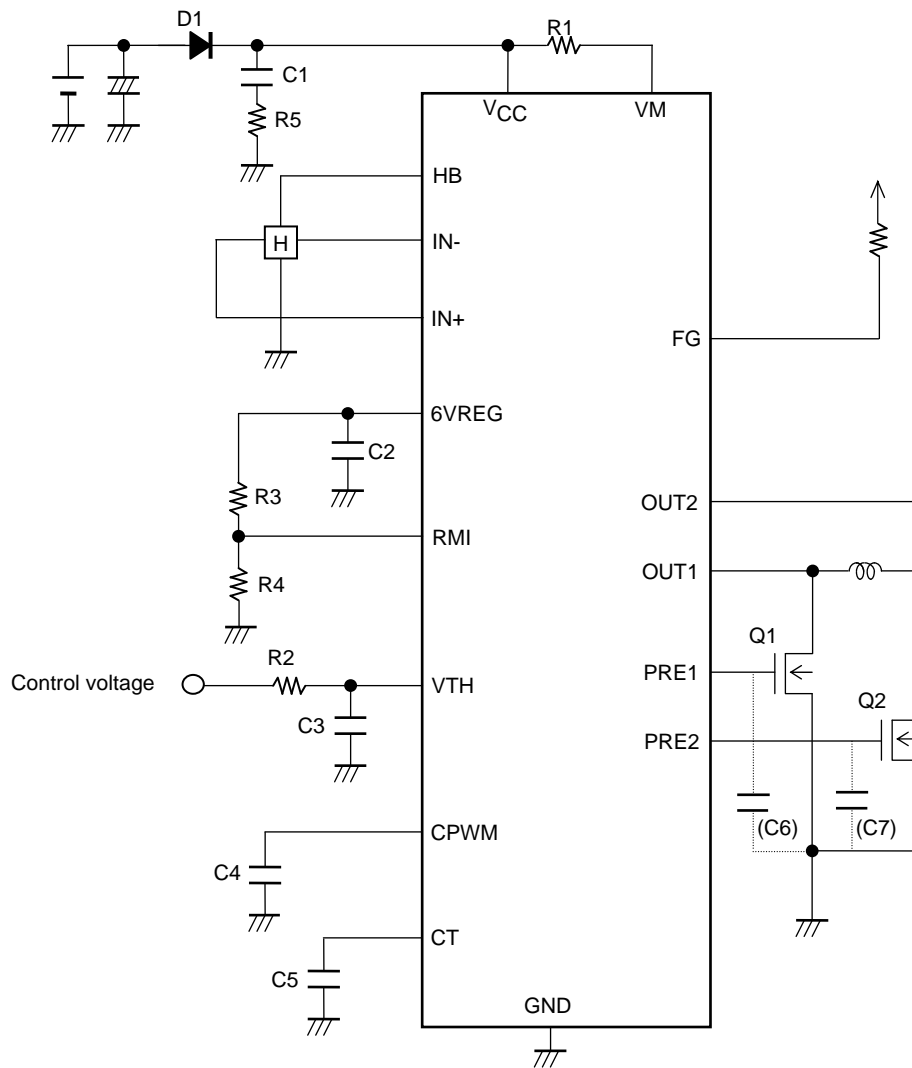

### Parts List

- D1 : SBM30-03-Tr (Our product)
- Q1, 2 : CPH3418 (Our product)
- R1 : 0.51 $\Omega$  size 3225
- R2 : 15k $\Omega$  size 1608
- R3 : 39k $\Omega$  size 1608
- R4 : 20k $\Omega$  size 1608
- R5 : 2.2 $\Omega$  size 1608
- C1 : 4.7 $\mu$ F/25V size 3216
- C2 : 2.2 $\mu$ F size 1608
- C3 : 2.2 $\mu$ F size 1608
- C4 : 220pF size 1005
- C5 : 0.47 $\mu$ F size 1608
- C6, 7 : No connection

# LB11660FV

## Application Circuit Example 3

No minimum speed setting, thermistor input used

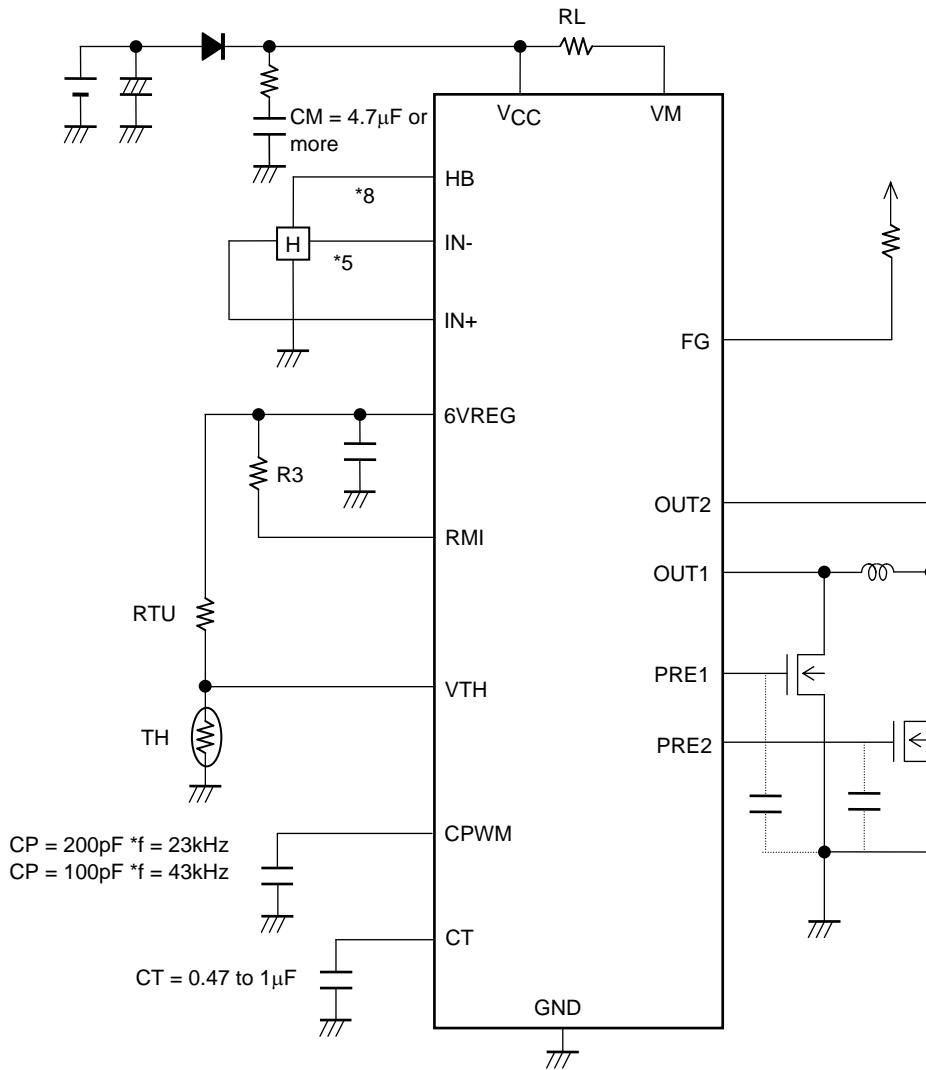

# LB11660FV

## Internal Equivalent Circuit Diagram

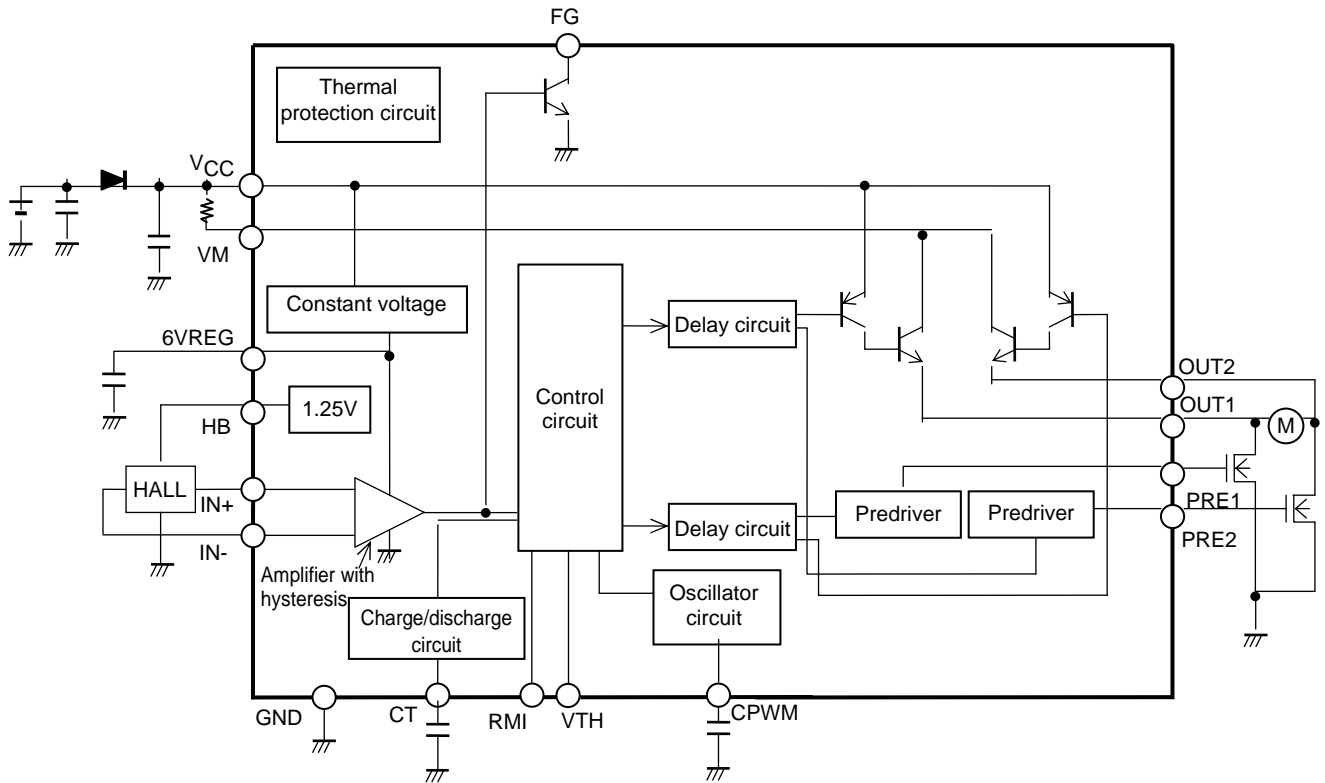

### ORDERING INFORMATION

Device	Package	Wire Bond	Shipping (Qty / Packing)
LB11660FV-MPB-H	SSOP16 (225mil) (Pb-Free / Halogen Free)	Au-Wire	90 / Fan-Fold
LB11660FV-TLM-H	SSOP16 (225mil) (Pb-Free / Halogen Free)	Au-Wire	2000 / Tape & Reel
LB11660FV-W-AH	SSOP16 (225mil) (Pb-Free / Halogen Free)	Cu-Wire	2000 / Tape & Reel

† For information on tape and reel specifications, including part orientation and tape sizes, please refer to our Tape and Reel Packaging Specifications Brochure, BRD8011/D. [http://www.onsemi.com/pub\\_link/Collateral/BRD8011-D.PDF](http://www.onsemi.com/pub_link/Collateral/BRD8011-D.PDF)

ON Semiconductor and the ON logo are registered trademarks of Semiconductor Components Industries, LLC (SCILLC) or its subsidiaries in the United States and/or other countries. SCILLC owns the rights to a number of patents, trademarks, copyrights, trade secrets, and other intellectual property. A listing of SCILLC's product/patent coverage may be accessed at [www.onsemi.com/site/pdf/Patent-Marking.pdf](http://www.onsemi.com/site/pdf/Patent-Marking.pdf). SCILLC reserves the right to make changes without further notice to any products herein. SCILLC makes no warranty, representation or guarantee regarding the suitability of its products for any particular purpose, nor does SCILLC assume any liability arising out of the application or use of any product or circuit, and specifically disclaims any and all liability, including without limitation special, consequential or incidental damages. "Typical" parameters which may be provided in SCILLC data sheets and/or specifications can and do vary in different applications and actual performance may vary over time. All operating parameters, including "Typicals" must be validated for each customer application by customer's technical experts. SCILLC does not convey any license under its patent rights nor the rights of others. SCILLC products are not designed, intended, or authorized for use as components in systems intended for surgical implant into the body, or other applications intended to support or sustain life, or for any other application in which the failure of the SCILLC product could create a situation where personal injury or death may occur. Should Buyer purchase or use SCILLC products for any such unintended or unauthorized application, Buyer shall indemnify and hold SCILLC and its officers, employees, subsidiaries, affiliates, and distributors harmless against all claims, costs, damages, and expenses, and reasonable attorney fees arising out of, directly or indirectly, any claim of personal injury or death associated with such unintended or unauthorized use, even if such claim alleges that SCILLC was negligent regarding the design or manufacture of the part. SCILLC is an Equal Opportunity/Affirmative Action Employer. This literature is subject to all applicable copyright laws and is not for resale in any manner.

## Looking for pricing, stock, or lifecycle information?

Click below to explore more details on WIN SOURCE:

- ⊖ [View LB11660FV-TLM-H on WIN SOURCE](#)
- ⊖ [ON Semiconductor](#) Information

## Optimize Your Supply Chain with WIN SOURCE Solutions

- ✓ Global Sourcing Solution
- ✓ Obsolete Management
- ✓ Cost Control Management
- ✓ Shortage Management
- ✓ Alternative Solution
- ✓ Excess Inventory Management