

# USB 2.0 Hub and 10/100 Ethernet Controller

## PRODUCT FEATURES

Data Brief

### Highlights

- Three downstream ports, one upstream port
  - Three integrated downstream USB 2.0 PHYs
  - One integrated upstream USB 2.0 PHY
- Integrated 10/100 Ethernet MAC with full-duplex support
- Integrated 10/100 Ethernet PHY with HP Auto-MDIX
- Implements Reduced Power Operating Modes
- Minimized BOM Cost
  - Single 25 MHz crystal (Eliminates cost of separate crystals for USB and Ethernet)
  - Built-in Power-On-Reset (POR) circuit (Eliminates requirement for external passive or active reset)

### Target Applications

- Desktop PCs
- Notebook PCs
- Printers
- Game Consoles
- Embedded Systems
- Docking Stations

### Key Features

- USB Hub
  - Fully compliant with Universal Serial Bus Specification Revision 2.0
  - HS (480 Mbps), FS (12 Mbps), and LS (1.5 Mbps) compatible
  - Three downstream ports, one upstream port
  - Port mapping and disable support
  - Port Swap: Programmable USB diff-pair pin location
  - PHY Boost: Programmable USB signal drive strength
  - Select presence of a permanently hardwired USB peripheral device on a port by port basis
  - Advanced power saving features
  - Downstream PHY goes into low power mode when port power to the port is disabled
  - Full Power Management with individual or ganged power control of each downstream port.
  - Integrated USB termination Pull-up/Pull-down resistors
  - Internal short circuit protection of USB differential signal pins

- High-Performance 10/100 Ethernet Controller
  - Fully compliant with IEEE802.3/802.3u
  - Integrated Ethernet MAC and PHY
  - 10BASE-T and 100BASE-TX support
  - Full- and half-duplex support with flow control
  - Preamble generation and removal
  - Automatic 32-bit CRC generation and checking
  - Automatic payload padding and pad removal
  - Loop-back modes
  - TCP/UDP checksum offload support
  - Flexible address filtering modes
    - One 48-bit perfect address
    - 64 hash-filtered multicast addresses
    - Pass all multicast
    - Promiscuous mode
    - Inverse filtering
    - Pass all incoming with status report
  - Wakeup packet support
  - Integrated Ethernet PHY
    - Auto-negotiation, HP Auto-MDIX
    - Automatic polarity detection and correction
    - Energy Detect
- Power and I/Os
  - Three PHY LEDs
  - Eight GPIOs
  - Supports bus-powered and self-powered operation
  - Internal 1.8v core supply regulator
  - External 3.3v I/O supply
- Miscellaneous features
  - Optional EEPROM
  - Optional 24MHz reference clock output for partner hub
  - IEEE 1149.1 (JTAG) Boundary Scan
- Software
  - Windows 2000/XP/Vista Driver
  - Linux Driver
  - Win CE Driver
  - MAC OS Driver
  - EEPROM Utility
- Packaging
  - 64-pin QFN, lead-free RoHS compliant
- Environmental
  - Commercial Temperature Range (0°C to +70°C)
  - Industrial Temperature Range (-40°C to +85°C)
  - ±8kV HBM without External Protection Devices
  - ±8kV contact mode (IEC61000-4-2)
  - ±15kV air-gap discharge mode (IEC61000-4-2)

**Order Numbers:****LAN9513-JZX for 64-pin, QFN lead-free RoHS compliant package (0 to +70°C temp range)****LAN9513i-JZX for 64-pin, QFN lead-free RoHS compliant package (-40 to +85°C temp range)****This product meets the halogen maximum concentration values per IEC61249-2-21****For RoHS compliance and environmental information, please visit [www.smSC.com/rohs](http://www.smSC.com/rohs)**

Copyright © 2012 SMSC or its subsidiaries. All rights reserved.

Circuit diagrams and other information relating to SMSC products are included as a means of illustrating typical applications. Consequently, complete information sufficient for construction purposes is not necessarily given. Although the information has been checked and is believed to be accurate, no responsibility is assumed for inaccuracies. SMSC reserves the right to make changes to specifications and product descriptions at any time without notice. Contact your local SMSC sales office to obtain the latest specifications before placing your product order. The provision of this information does not convey to the purchaser of the described semiconductor devices any licenses under any patent rights or other intellectual property rights of SMSC or others. All sales are expressly conditional on your agreement to the terms and conditions of the most recently dated version of SMSC's standard Terms of Sale Agreement dated before the date of your order (the "Terms of Sale Agreement"). The product may contain design defects or errors known as anomalies which may cause the product's functions to deviate from published specifications. Anomaly sheets are available upon request. SMSC products are not designed, intended, authorized or warranted for use in any life support or other application where product failure could cause or contribute to personal injury or severe property damage. Any and all such uses without prior written approval of an Officer of SMSC and further testing and/or modification will be fully at the risk of the customer. Copies of this document or other SMSC literature, as well as the Terms of Sale Agreement, may be obtained by visiting SMSC's website at <http://www.smSC.com>. SMSC is a registered trademark of Standard Microsystems Corporation ("SMSC"). Product names and company names are the trademarks of their respective holders.

**SMSC DISCLAIMS AND EXCLUDES ANY AND ALL WARRANTIES, INCLUDING WITHOUT LIMITATION ANY AND ALL IMPLIED WARRANTIES OF MERCHANTABILITY, FITNESS FOR A PARTICULAR PURPOSE, TITLE, AND AGAINST INFRINGEMENT AND THE LIKE, AND ANY AND ALL WARRANTIES ARISING FROM ANY COURSE OF DEALING OR USAGE OF TRADE. IN NO EVENT SHALL SMSC BE LIABLE FOR ANY DIRECT, INCIDENTAL, INDIRECT, SPECIAL, PUNITIVE, OR CONSEQUENTIAL DAMAGES; OR FOR LOST DATA, PROFITS, SAVINGS OR REVENUES OF ANY KIND; REGARDLESS OF THE FORM OF ACTION, WHETHER BASED ON CONTRACT; TORT; NEGLIGENCE OF SMSC OR OTHERS; STRICT LIABILITY; BREACH OF WARRANTY; OR OTHERWISE; WHETHER OR NOT ANY REMEDY OF BUYER IS HELD TO HAVE FAILED OF ITS ESSENTIAL PURPOSE, AND WHETHER OR NOT SMSC HAS BEEN ADVISED OF THE POSSIBILITY OF SUCH DAMAGES.**

# Overview

The LAN9513/LAN9513i is a high performance Hi-Speed USB 2.0 hub with a 10/100 Ethernet controller. With applications ranging from embedded systems, desktop PCs, notebook PCs, printers, game consoles, and docking stations, the LAN9513/LAN9513i is targeted as a high performance, low cost USB/Ethernet and USB/USB connectivity solution.

The LAN9513/LAN9513i contains an integrated USB 2.0 hub, three integrated downstream USB 2.0 PHYs, an integrated upstream USB 2.0 PHY, a 10/100 Ethernet PHY, a 10/100 Ethernet Controller, a TAP controller, and a EEPROM controller. A block diagram of the LAN9513/LAN9513i is provided in [Figure 1](#).

The LAN9513/LAN9513i hub provides over 30 programmable features, including:

**PortMap** (also referred to as port remap) which provides flexible port mapping and disabling sequences. The downstream ports of the LAN9513/LAN9513i hub can be reordered or disabled in any sequence to support multiple platform designs with minimum effort. For any port that is disabled, the LAN9513/LAN9513i automatically reorders the remaining ports to match the USB host controller's port numbering scheme.

**PortSwap** which adds per-port programmability to USB differential-pair pin locations. PortSwap allows direct alignment of USB signals (D+/D-) to connectors avoiding uneven trace length or crossing of the USB differential signals on the PCB.

**PHYBoost** which enables four programmable levels of USB signal drive strength in USB port transceivers. PHYBoost attempts to restore USB signal integrity that has been compromised by system level variables such as poor PCB layout, long cables, etc..

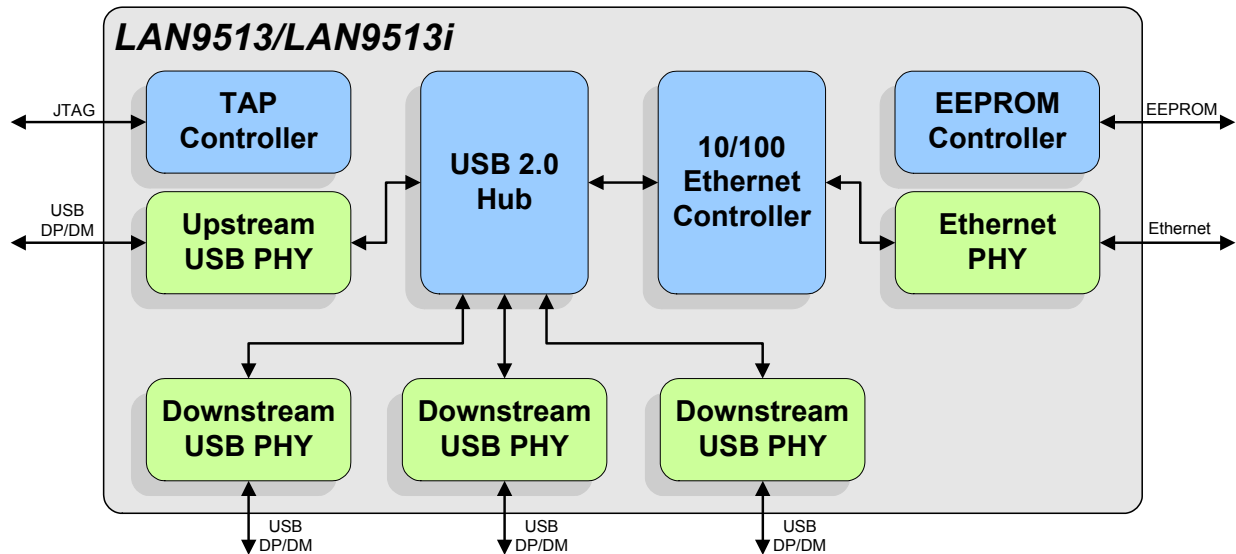

Figure 1 Internal Block Diagram

# Package Outline

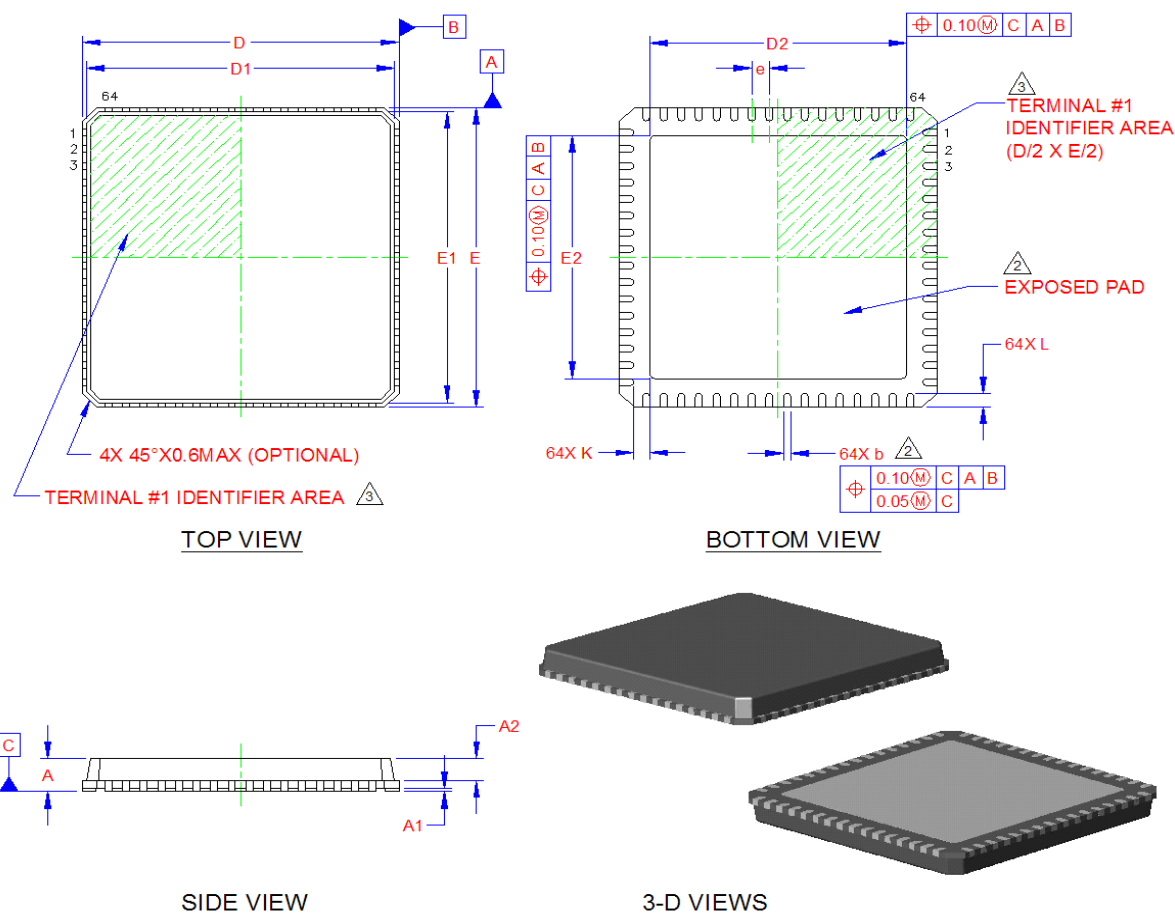

Figure 2 LAN9513/LAN9513i 64-QFN Package Definition

Table 1 LAN9513/LAN9513i 64-QFN Dimensions

	MIN	NOMINAL	MAX	REMARKS
A	0.80	0.85	1.00	Overall Package Height
A1	0.00	0.02	0.05	Standoff
A2	-	0.65	0.80	Mold Cap Thickness
D/E	8.90	9.00	9.10	X/Y Body Size
D1/E1	8.65	8.75	8.85	X/Y Mold Cap Size
D2/E2	7.20	7.30	7.40	X/Y Exposed Pad Size
L	0.30	0.40	0.50	Terminal Length
b	0.18	0.25	0.30	Terminal Width
e	0.50 BSC			Terminal Pitch
K	0.35	-	-	Pin to Center Pad Clearance

**Notes:**

1. All dimensions are in millimeters unless otherwise noted.
2. Dimension "b" applies to plated terminals and is measured between 0.15 and 0.30 mm from the terminal tip.
3. Details of terminal #1 identifier are optional, but must be located within the area indicated. The terminal #1 identifier may be either a mold or marked feature.

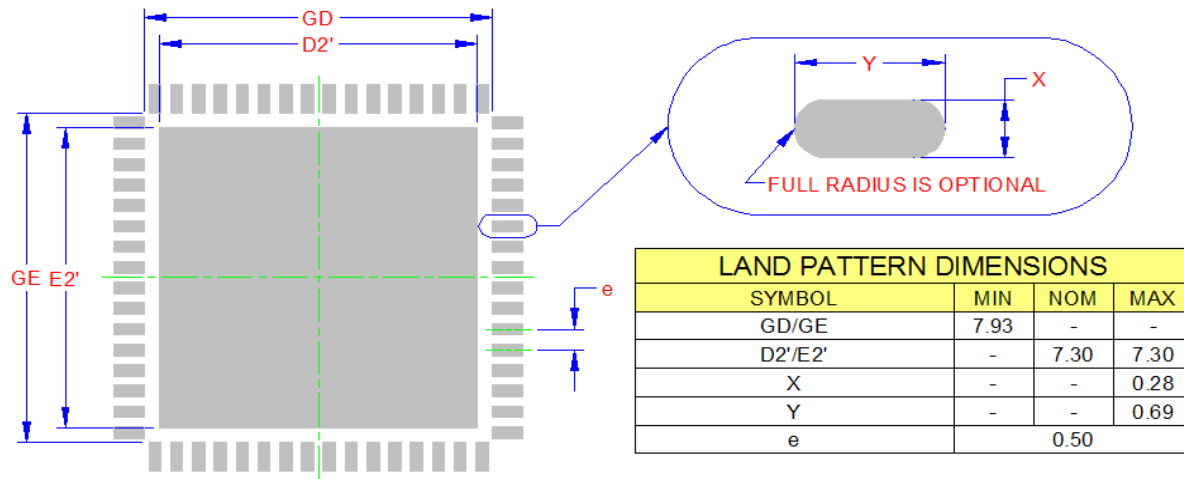

THE USER MAY MODIFY THE PCB LAND PATTERN DIMENSIONS  
BASED ON THEIR EXPERIENCE AND/OR PROCESS CAPABILITY

RECOMMENDED PCB LAND PATTERN

**Figure 3 LAN9513/LAN9513i Recommended PCB Land Pattern**

## Looking for pricing, stock, or lifecycle information?

Click below to explore more details on WIN SOURCE:

- ⊖ [View LAN9513-JZX on WIN SOURCE](#)
- ⊖ [Microchip Technology](#) Information

## Optimize Your Supply Chain with WIN SOURCE Solutions

- ✓ Global Sourcing Solution
- ✓ Obsolete Management
- ✓ Cost Control Management
- ✓ Shortage Management
- ✓ Alternative Solution
- ✓ Excess Inventory Management