



LAN83C185

High Performance Single Chip Low Power 10/100 Ethernet Physical Layer Transceiver (PHY)

Highlights

- Single Chip Ethernet Phy
- Fully compliant with IEEE 802.3/802.3u standards
- 10BASE-T and 100BASE-TX support
- Supports Auto-negotiation and Parallel Detection
- Automatic Polarity Correction
- Integrated DSP with Adaptive Equalizer
- Baseline Wander (BLW) Correction
- Media Independent Interface (MII)
- 802.3u compliant register functions
- Vendor Specific register functions
- Comprehensive power management features
- General power-down mode
- Energy Detect power-down mode
- Low profile 64-pin TQFP RoHS compliant package
- Single +3.3V supply with 5V tolerant I/O
- 0.18 micron technology
- Low power consumption
- Operating Temperature 0° C to 70° C
- Internal +1.8V Regulator

Applications

- LAN on Motherboard
- 10/100 PCMCIA/CardBus Applications
- Embedded Telecom Applications
- Video Record/Playback Systems
- Cable Modems And Set-Top Boxes
- Digital Televisions
- Wireless Access Points

TO OUR VALUED CUSTOMERS

It is our intention to provide our valued customers with the best documentation possible to ensure successful use of your Microchip products. To this end, we will continue to improve our publications to better suit your needs. Our publications will be refined and enhanced as new volumes and updates are introduced.

If you have any questions or comments regarding this publication, please contact the Marketing Communications Department via E-mail at docerrors@microchip.com. We welcome your feedback.

Most Current Data Sheet

To obtain the most up-to-date version of this data sheet, please register at our Worldwide Web site at:

<http://www.microchip.com>

You can determine the version of a data sheet by examining its literature number found on the bottom outside corner of any page. The last character of the literature number is the version number, (e.g., DS30000000A is version A of document DS30000000).

Errata

An errata sheet, describing minor operational differences from the data sheet and recommended workarounds, may exist for current devices. As device/documentation issues become known to us, we will publish an errata sheet. The errata will specify the revision of silicon and revision of document to which it applies.

To determine if an errata sheet exists for a particular device, please check with one of the following:

- Microchip's Worldwide Web site; <http://www.microchip.com>
- Your local Microchip sales office (see last page)

When contacting a sales office, please specify which device, revision of silicon and data sheet (include -literature number) you are using.

Customer Notification System

Register on our web site at www.microchip.com to receive the most current information on all of our products.

Table of Contents

- 1.0 General Description 4
- 2.0 Pin Configuration 5
- 3.0 Pin Description 7
- 4.0 Architecture Details 11
- 5.0 Registers 21
- 6.0 Electrical Characteristics 41
- 7.0 Package Outline 50
- Appendix A: Data Sheet Revision History 51
- The Microchip Web Site 52
- Customer Change Notification Service 52
- Customer Support 52
- Product Identification System 53

LAN83C185

1.0 GENERAL DESCRIPTION

The Microchip LAN83C185 is a low-power, highly integrated analog interface IC for high-performance embedded Ethernet applications. The LAN83C185 requires only a single +3.3V supply.

The LAN83C185 consists of an encoder/decoder, scrambler/descrambler, transmitter with wave-shaping and output driver, twisted-pair receiver with on-chip adaptive equalizer and baseline wander (BLW) correction, clock and data recovery, and Media Independent Interface (MII).

The LAN83C185 is fully compliant with IEEE 802.3/ 802.3u standards and supports both 802.3u-compliant and vendor-specific register functions. It contains a full-duplex 10-BASE-T/100BASE-TX transceiver and supports 10-Mbps (10BASE-T) operation on Category 3 and Category 5 unshielded twisted-pair cable, and 100-Mbps (100BASE-TX) operation on Category 5 unshielded twisted-pair cable.

1.1 Architectural Overview

FIGURE 1-1: LAN83C185 ARCHITECTURAL OVERVIEW

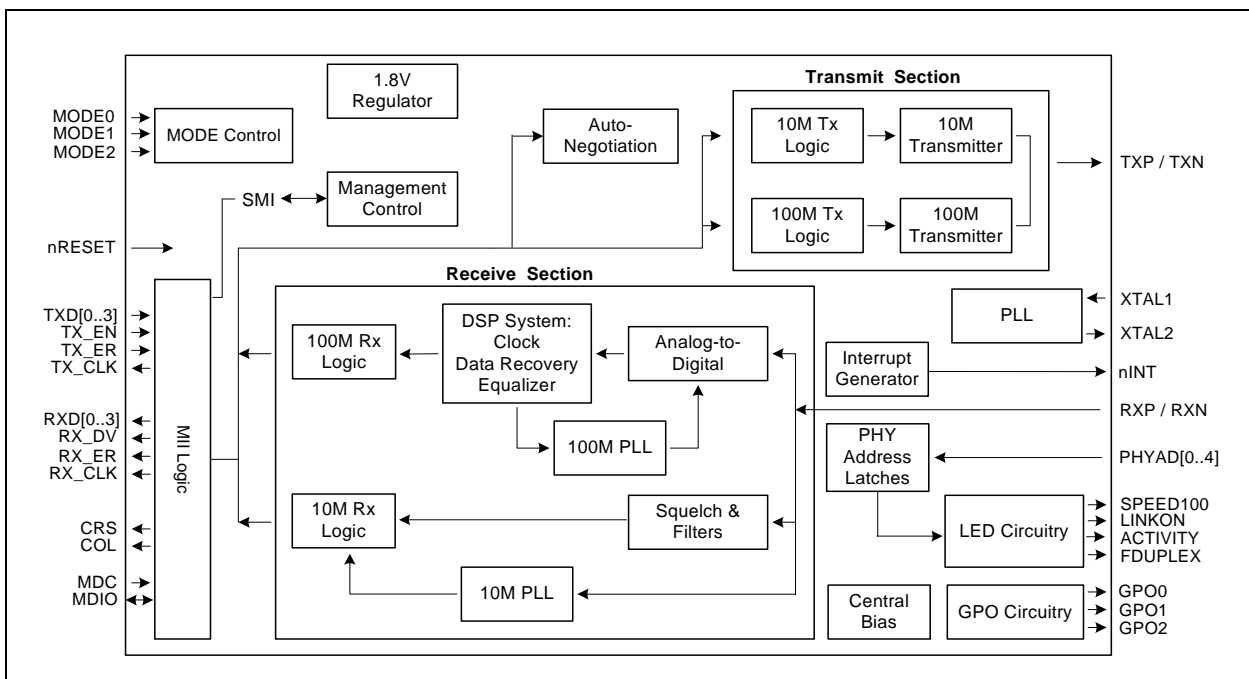

2.0 PIN CONFIGURATION

FIGURE 2-1: PACKAGE PIN LAYOUT

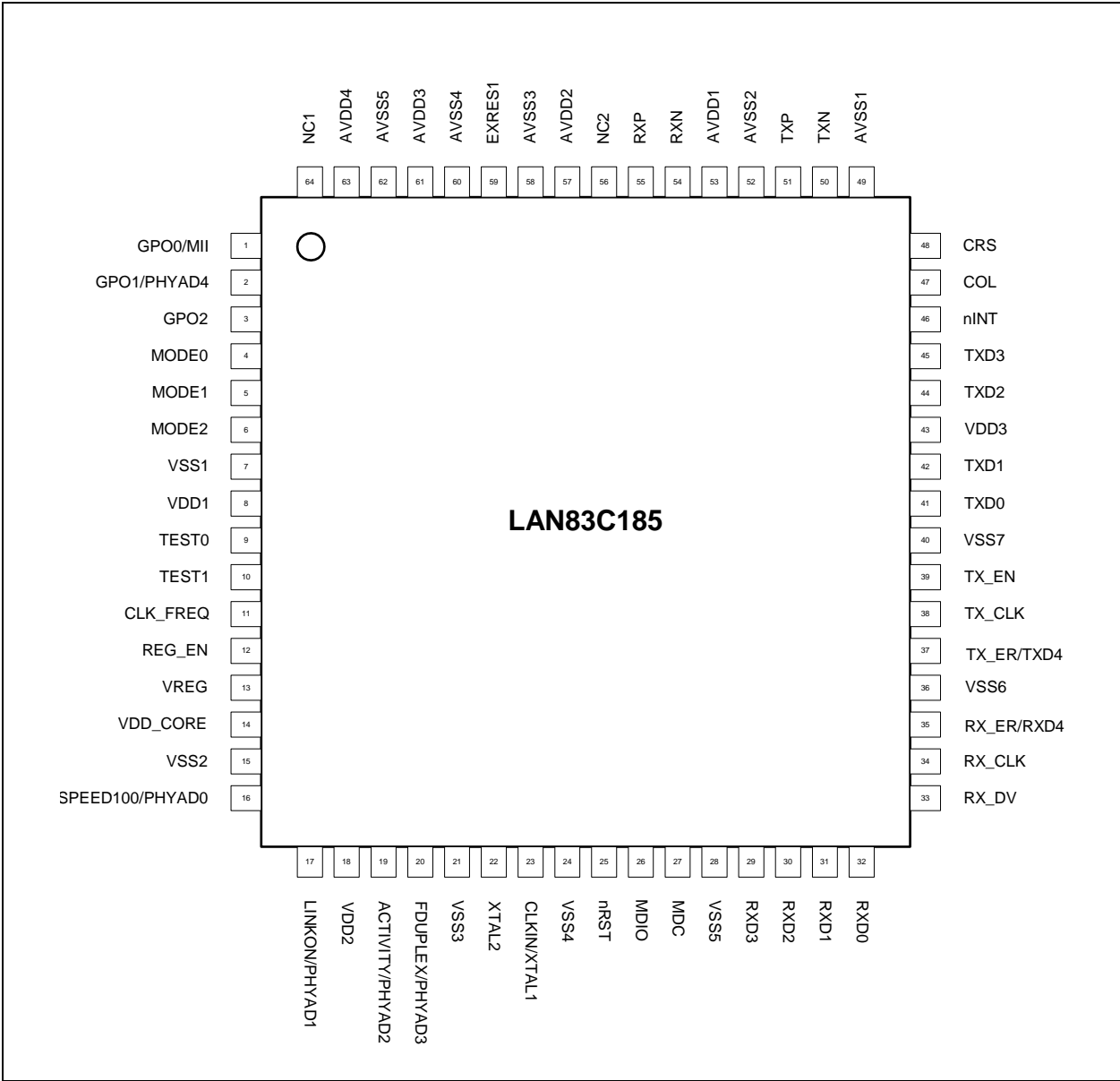

LAN83C185

TABLE 2-1: LAN83C185 64-PIN TQFP PIN LAYOUT

| Pin No. | Pin Name | Pin No. | Pin Name |
|---------|-----------------|---------|------------|
| 1 | GPO0/MII | 33 | RX_DV |
| 2 | GPO1/PHYAD4 | 34 | RX_CLK |
| 3 | GPO2 | 35 | RX_ER/RXD4 |
| 4 | MODE0 | 36 | VSS6 |
| 5 | MODE1 | 37 | TX_ER/TXD4 |
| 6 | MODE2 | 38 | TX_CLK |
| 7 | VSS1 | 39 | TX_EN |
| 8 | VDD1 | 40 | VSS7 |
| 9 | TEST0 | 41 | TXD0 |
| 10 | TEST1 | 42 | TXD1 |
| 11 | CLK_FREQ | 43 | VDD3 |
| 12 | REG_EN | 44 | TXD2 |
| 13 | VREG | 45 | TXD3 |
| 14 | VDD_CORE | 46 | nINT |
| 15 | VSS2 | 47 | COL |
| 16 | SPEED100/PHYAD0 | 48 | CRS |
| 17 | LINKON/PHYAD1 | 49 | AVSS1 |
| 18 | VDD2 | 50 | TXN |
| 19 | ACTIVITY/PHYAD2 | 51 | TXP |
| 20 | FDUPLEX/PHYAD3 | 52 | AVSS2 |
| 21 | VSS3 | 53 | AVDD1 |
| 22 | XTAL2 | 54 | RXN |
| 23 | CLKIN/XTAL1 | 55 | RXP |
| 24 | VSS4 | 56 | NC2 |
| 25 | nRST | 57 | AVDD2 |
| 26 | MDIO | 58 | AVSS3 |
| 27 | MDC | 59 | EXRES1 |
| 28 | VSS5 | 60 | AVSS4 |
| 29 | RXD3 | 61 | AVDD3 |
| 30 | RXD2 | 62 | AVSS5 |
| 31 | RXD1 | 63 | AVDD4 |
| 32 | RXD0 | 64 | NC1 |

3.0 PIN DESCRIPTION

This chapter describes in detail the functionality of each of the five main architectural blocks.

The term “block” defines a stand-alone entity on the floor plan of the chip.

3.1 I/O Signals

| | |
|------|---------------------------------|
| I | Input. Digital TTL levels. |
| O | Output. Digital TTL levels. |
| AI | Input. Analog levels. |
| AO | Output. Analog levels. |
| AI/O | Input or Output. Analog levels. |

Note: Reset as used in the signal descriptions is defined as nRST being active low.

Configuration inputs are listed in parenthesis.

TABLE 3-1: MII SIGNALS

| Pin No. | Signal Name | Type | Description |
|---------|-----------------|--------|---|
| 41 | TXD0 | I | Transmit Data 0: Bit 0 of the 4 data bits that are accepted by the PHY for transmission. |
| 42 | TXD1 | I | Transmit Data 1: Bit 1 of the 4 data bits that are accepted by the PHY for transmission. |
| 39 | TX_EN | I | Transmit Enable: Indicates that valid data is presented on the TXD[3:0] signals, for transmission. |
| 35 | RX_ER (RXD4) | O O | Receive Error: Asserted to indicate that an error was detected somewhere in the frame presently being transferred from the PHY. In Symbol Interface (5B Decoding) mode, this signal is the MII Receive Data 4: the MSB of the received 5-bit symbol code-group. |
| 47 | COL | O | MII Collision Detect: Asserted to indicate detection of collision condition. |
| 32 | RXD0 | O | Receive Data 0: Bit 0 of the 4 data bits that are sent by the PHY in the receive path. |
| 31 | RXD1 | O | Receive Data 1: Bit 1 of the 4 data bits that are sent by the PHY in the receive path. |
| 44 | TXD2 | I | Transmit Data 2: Bit 2 of the 4 data bits that are accepted by the PHY for transmission. |
| 45 | TXD3 | I | Transmit Data 3: Bit 3 of the 4 data bits that are accepted by the PHY for transmission. |
| 37 | TX_ER (TXD4) | I I | MII Transmit Error: When driven high, the 4B/5B encode process substitutes the Transmit Error code-group (/H/) for the encoded data word. This input is ignored in 10BaseT operation. In Symbol Interface (5B Decoding) mode, this signal becomes the MII Transmit Data 4: the MSB of the 5-bit symbol code-group. |
| 48 | CRS | O | Carrier Sense: Indicate detection of carrier. |
| 33 | RX_DV | O | Receive Data Valid: Indicates that recovered and decoded data nibbles are being presented on RXD[3:0]. |

LAN83C185

TABLE 3-1: MII SIGNALS (CONTINUED)

| Pin No. | Signal Name | Type | Description |
|---------|-------------|------|---|
| 30 | RXD2 | O | Receive Data 2: Bit 2 of the 4 data bits that sent by the PHY in the receive path. |
| 29 | RXD3 | O | Receive Data 3: Bit 3 of the 4 data bits that sent by the PHY in the receive path. |
| 38 | TX_CLK | O | Transmit Clock: 25MHz in 100Base-TX mode. 2.5MHz in 10Base-T mode. |
| 34 | RX_CLK | O | Receive Clock: 25MHz in 100Base-TX mode. 2.5MHz in 10Base-T mode. |

TABLE 3-2: LED SIGNALS

| Pin No. | Signal Name | Type | Description |
|---------|-------------|------|---|
| 16 | SPEED100 | O | LED1 – SPEED100 indication. Active indicates that the selected speed is 100Mbps. Inactive indicates that the selected speed is 10Mbps. |
| 17 | LINKON | O | LED2 – LINK ON indication. Active indicates that the Link (100Base-TX or 10Base-T) is on. |
| 19 | ACTIVITY | O | LED3 – ACTIVITY indication. Active indicates that there is Carrier sense (CRS) from the active PMD. |
| 20 | FDUPLEX | O | LED4 – DUPLEX indication. Active indicates that the PHY is in full-duplex mode. |

TABLE 3-3: MANAGEMENT SIGNALS

| Pin No. | Signal Name | Type | Description |
|---------|-------------|------|---|
| 26 | MDIO | IO | Management Data Input/OUTPUT: Serial management data input/output. |
| 27 | MDC | I | Management Clock: Serial management clock. |

TABLE 3-4: CONFIGURATION INPUTS

| Pin No. | Signal Name | Type | Description |
|---------|-------------|------|---|
| 2 | PHYAD4 | I | PHY Address Bit 4: set the default address of the PHY. |
| 20 | PHYAD3 | I | PHY Address Bit 3: set the default address of the PHY. |
| 19 | PHYAD2 | I | PHY Address Bit 2: set the default address of the PHY. |
| 17 | PHYAD1 | I | PHY Address Bit 1: set the default address of the PHY. |
| 16 | PHYAD0 | I | PHY Address Bit 0: set the default address of the PHY. |
| 6 | MODE2 | I | PHY Operating Mode Bit 2: set the default MODE of the PHY. See Section 5.4.9.2, "Mode Bus – MODE[2:0]," on page 38 for the MODE options. |
| 5 | MODE1 | I | PHY Operating Mode Bit 1: set the default MODE of the PHY. See Section 5.4.9.2, "Mode Bus – MODE[2:0]," on page 38 for the MODE options. |
| 4 | MODE0 | I | PHY Operating Mode Bit 0: set the default MODE of the PHY. See Section 5.4.9.2, "Mode Bus – MODE[2:0]," on page 38 for the MODE options. |
| 10 | TEST1 | I | Test Mode Select 1: Must be left floating. |

TABLE 3-4: CONFIGURATION INPUTS (CONTINUED)

| Pin No. | Signal Name | Type | Description |
|---------|-------------|------|--|
| 9 | TEST0 | I | Test Mode Select 0: Must be left floating. |
| 12 | REG_EN | I | Internal +1.8V Regulator Enable: +3.3V – Enables internal regulator. 0V – Disables internal regulator. |

TABLE 3-5: GENERAL SIGNALS

| Pin No. | Signal Name | Type | Description |
|---------|-------------|------|--|
| 46 | nINT | OD | LAN Interrupt – Active Low output. |
| 25 | nRST | I | External Reset – input of the system reset. This signal is active LOW. |
| 23 | CLKIN/XTAL1 | I | Clock Input – 25 MHz external clock or crystal input. |
| 22 | XTAL2 | O | Clock Output – 25 MHz crystal output. |
| 11 | CLK_FREQ | I | Clock Frequency – define the frequency of the input clock CLKIN 0 – Clock frequency is 25 MHz. 1 – Reserved. This input needs to be held low continuously, during and after reset. This pin should be pulled-down to VSS via a pull-down resistor. |
| 64 | NC1 | | No Connect |
| 3 | GPO2 | O | General Purpose Output 2 – General Purpose Output signal Driven by bits in registers 27 and 31. |
| 2 | GPO1 | O | General Purpose Output 1 – General Purpose Output signal Driven by bits in registers 27 and 31. (Muxed with PHYAD4 signal) |
| 1 | GPO0 | O | General Purpose Output 0 – General Purpose Output signal. Driven by bits in registers 27 and 31. (Muxed with MII Select) This pin should be pulled-down or left floating – Do Not Pull Up. |

TABLE 3-6: 10/100 LINE INTERFACE

| Pin No. | Signal Name | Type | Description |
|---------|-------------|------|--|
| 51 | TXP | AO | Transmit Data: 100Base-TX or 10Base-T differential transmit outputs to magnetics. |
| 50 | TXN | AO | Transmit Data: 100Base-TX or 10Base-T differential transmit outputs to magnetics. |
| 55 | RXP | AI | Receive Data: 100Base-TX or 10Base-T differential receive inputs from magnetics. |
| 54 | RXN | AI | Receive Data: 100Base-TX or 10Base-T differential receive inputs from magnetics. |

TABLE 3-7: ANALOG REFERENCES

| Pin No. | Signal Name | Type | Description |
|---------|-------------|------|---|
| 59 | EXRES1 | AI | Connects to reference resistor of value 12.4K-Ohm, 1% connected to digital GND. |

LAN83C185

TABLE 3-8: ANALOG TEST BUS

| Pin No. | Signal Name | Type | Description |
|---------|-------------|------|-------------|
| 56 | NC2 | AI/O | No Connect |

TABLE 3-9: POWER SIGNALS

| Pin No. | Signal Name | Type | Description |
|---------|-------------|-------|--|
| 53 | AVDD1 | Power | +3.3V Analog Power |
| 57 | AVDD2 | Power | +3.3V Analog Power |
| 61 | AVDD3 | Power | +3.3V Analog Power |
| 63 | AVDD4 | Power | +3.3V Analog Power |
| 49 | AVSS1 | Power | Analog Ground |
| 52 | AVSS2 | Power | Analog Ground |
| 58 | AVSS3 | Power | Analog Ground |
| 60 | AVSS4 | Power | Analog Ground |
| 62 | AVSS5 | Power | Analog Ground |
| 13 | VREG | Power | +3.3V Internal Regulator Input Voltage |
| 14 | VDD_CORE | Power | +1.8V Ring (Core voltage) - required for capacitance connection. |
| 8 | VDD1 | Power | +3.3V Digital Power |
| 18 | VDD2 | Power | +3.3V Digital Power |
| 43 | VDD3 | Power | +3.3V Digital Power |
| 7 | VSS1 | Power | Digital Ground (GND) |
| 15 | VSS2 | Power | Digital Ground (GND) |
| 21 | VSS3 | Power | Digital Ground (GND) |
| 24 | VSS4 | Power | Digital Ground (GND) |
| 28 | VSS5 | Power | Digital Ground (GND) |
| 36 | VSS6 | Power | Digital Ground (GND) |
| 40 | VSS7 | Power | Digital Ground (GND) |

4.0 ARCHITECTURE DETAILS

4.1 Top Level Functional Architecture

Functionally, the PHY can be divided into the following sections:

- 100Base-TX transmit and receive
- 10Base-T transmit and receive
- MII interface to the controller
- Auto-negotiation to automatically determine the best speed and duplex possible
- Management Control to read status registers and write control registers

FIGURE 4-1: 100BASE-TX DATA PATH

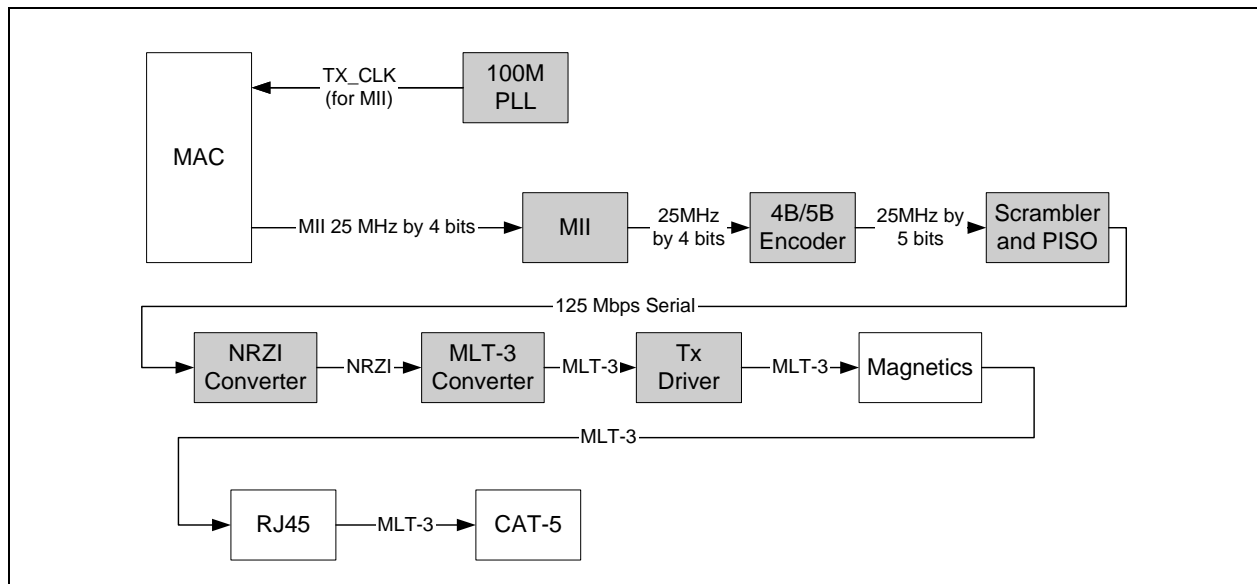

4.2 100Base-TX Transmit

The data path of the 100Base-TX is shown in [Figure 4-1](#). Each major block is explained below.

4.2.1 100M TRANSMIT DATA ACROSS THE MII

The MAC controller drives the transmit data onto the TXD bus and asserts TX_EN to indicate valid data. The data is latched by the PHY's MII block on the rising edge of TX_CLK. The data is in the form of 4-bit wide 25MHz data.

4.2.2 4B/5B ENCODING

The transmit data passes from the MII block to the 4B/5B encoder. This block encodes the data from 4-bit nibbles to 5-bit symbols (known as "code-groups") according to [Figure 4-1](#). Each 4-bit data-nibble is mapped to 16 of the 32 possible code-groups. The remaining 16 code-groups are either used for control information or are not valid.

The first 16 code-groups are referred to by the hexadecimal values of their corresponding data nibbles, 0 through F. The remaining code-groups are given letter designations with slashes on either side. For example, an IDLE code-group is /I/, a transmit error code-group is /H/, etc.

The encoding process may be bypassed by clearing bit 6 of register 31. When the encoding is bypassed the 5th transmit data bit is equivalent to TX_ER.

Note that encoding can be bypassed only when the MAC interface is configured to operate in MII mode.

LAN83C185

TABLE 4-1: 4B/5B CODE TABLE

| Code Group | SYM | Receiver Interpretation | | | Transmitter Interpretation | | |
|------------|-----|---|------|------|-----------------------------|------|------|
| | | | | | | | |
| 11110 | 0 | 0 | 0000 | DATA | 0 | 0000 | DATA |
| 01001 | 1 | 1 | 0001 | | 1 | 0001 | |
| 10100 | 2 | 2 | 0010 | | 2 | 0010 | |
| 10101 | 3 | 3 | 0011 | | 3 | 0011 | |
| 01010 | 4 | 4 | 0100 | | 4 | 0100 | |
| 01011 | 5 | 5 | 0101 | | 5 | 0101 | |
| 01110 | 6 | 6 | 0110 | | 6 | 0110 | |
| 01111 | 7 | 7 | 0111 | | 7 | 0111 | |
| 10010 | 8 | 8 | 1000 | | 8 | 1000 | |
| 10011 | 9 | 9 | 1001 | | 9 | 1001 | |
| 10110 | A | A | 1010 | | A | 1010 | |
| 10111 | B | B | 1011 | | B | 1011 | |
| 11010 | C | C | 1100 | | C | 1100 | |
| 11011 | D | D | 1101 | | D | 1101 | |
| 11100 | E | E | 1110 | | E | 1110 | |
| 11101 | F | F | 1111 | | F | 1111 | |
| 11111 | I | IDLE | | | Sent after /T/R until TX_EN | | |
| 11000 | J | First nibble of SSD, translated to "0101" following IDLE, else RX_ER | | | Sent for rising TX_EN | | |
| 10001 | K | Second nibble of SSD, translated to "0101" following J, else RX_ER | | | Sent for rising TX_EN | | |
| 01101 | T | First nibble of ESD, causes de-assertion of CRS if followed by /R/, else assertion of RX_ER | | | Sent for falling TX_EN | | |
| 00111 | R | Second nibble of ESD, causes deassertion of CRS if following /T/, else assertion of RX_ER | | | Sent for falling TX_EN | | |
| 00100 | H | Transmit Error Symbol | | | Sent for rising TX_ER | | |
| 00110 | V | INVALID, RX_ER if during RX_DV | | | INVALID | | |
| 11001 | V | INVALID, RX_ER if during RX_DV | | | INVALID | | |
| 00000 | V | INVALID, RX_ER if during RX_DV | | | INVALID | | |
| 00001 | V | INVALID, RX_ER if during RX_DV | | | INVALID | | |
| 00010 | V | INVALID, RX_ER if during RX_DV | | | INVALID | | |
| 00011 | V | INVALID, RX_ER if during RX_DV | | | INVALID | | |
| 00101 | V | INVALID, RX_ER if during RX_DV | | | INVALID | | |
| 01000 | V | INVALID, RX_ER if during RX_DV | | | INVALID | | |
| 01100 | V | INVALID, RX_ER if during RX_DV | | | INVALID | | |
| 10000 | V | INVALID, RX_ER if during RX_DV | | | INVALID | | |

4.2.3 SCRAMBLING

Repeated data patterns (especially the IDLE code-group) can have power spectral densities with large narrow-band peaks. Scrambling the data helps eliminate these peaks and spread the signal power more uniformly over the entire channel bandwidth. This uniform spectral density is required by FCC regulations to prevent excessive EMI from being radiated by the physical wiring.

The seed for the scrambler is generated from the PHY address, PHYAD[4:0], ensuring that in multiple-PHY applications, such as repeaters or switches, each PHY will have its own scrambler sequence.

The scrambler also performs the Parallel In Serial Out conversion (PISO) of the data.

4.2.4 NRZI AND MLT3 ENCODING

The scrambler block passes the 5-bit wide parallel data to the NRZI converter where it becomes a serial 125MHz NRZI data stream. The NRZI is encoded to MLT-3. MLT3 is a tri-level code where a change in the logic level represents a code bit "1" and the logic output remaining at the same level represents a code bit "0".

4.2.5 100M TRANSMIT DRIVER

The MLT3 data is then passed to the analog transmitter, which launches the differential MLT-3 signal, on outputs TXP and TXN, to the twisted pair media via a 1:1 ratio isolation transformer. The 10Base-T and 100Base-TX signals pass through the same transformer so that common "magnetics" can be used for both. The transmitter drives into the 100Ω impedance of the CAT-5 cable. Cable termination and impedance matching require external components.

4.2.6 100M PHASE LOCK LOOP (PLL)

The 100M PLL locks onto reference clock and generates the 125MHz clock used to drive the 125 MHz logic and the 100Base-Tx Transmitter.

FIGURE 4-2: RECEIVE DATA PATH

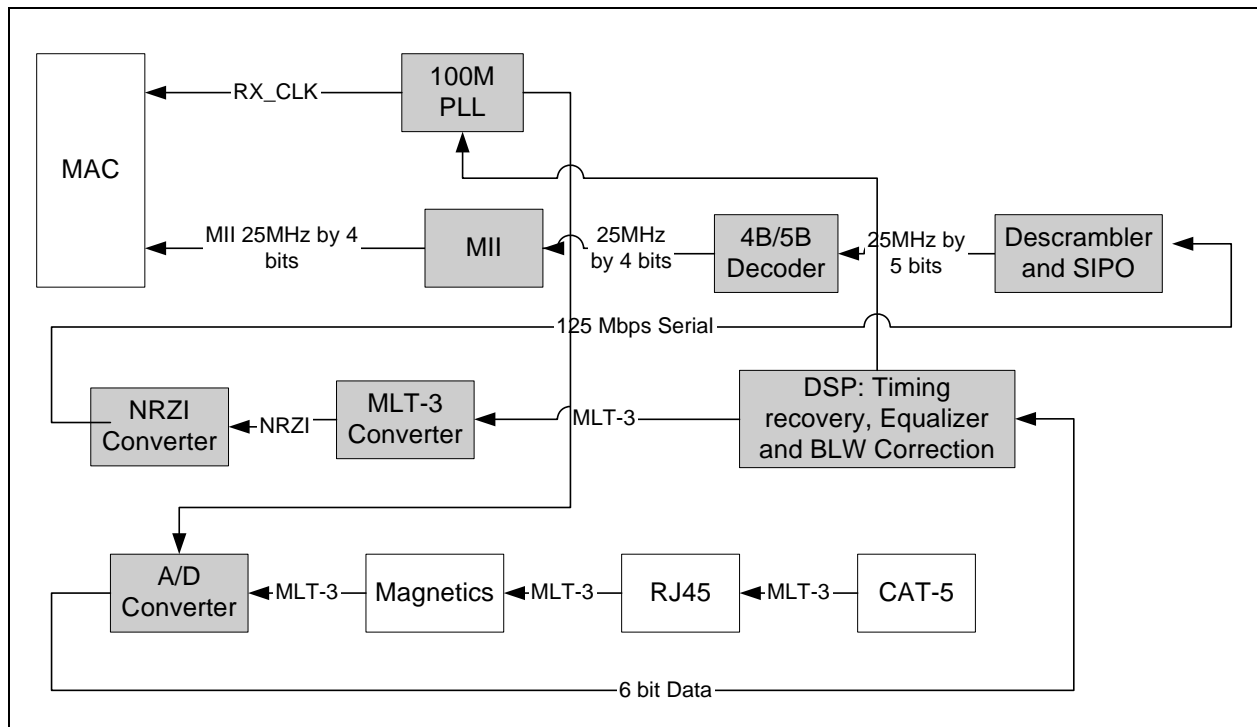

LAN83C185

4.3 100Base-TX Receive

The receive data path is shown in [Figure 4-2](#). Detailed descriptions are given below.

4.3.1 100M RECEIVE INPUT

The MLT-3 from the cable is fed into the PHY (on inputs RXP and RXN) via a 1:1 ratio transformer. The ADC samples the incoming differential signal at a rate of 125M samples per second. Using a 64-level quantizer it generates 6 digital bits to represent each sample. The DSP adjusts the gain of the ADC according to the observed signal levels such that the full dynamic range of the ADC can be used.

4.3.2 EQUALIZER, BASELINE WANDER CORRECTION AND CLOCK AND DATA RECOVERY

The 6 bits from the ADC are fed into the DSP block. The equalizer in the DSP section compensates for phase and amplitude distortion caused by the physical channel consisting of magnetics, connectors, and CAT-5 cable. The equalizer can restore the signal for any good-quality CAT-5 cable between 1m and 150m.

If the DC content of the signal is such that the low-frequency components fall below the low frequency pole of the isolation transformer, then the droop characteristics of the transformer will become significant and Baseline Wander (BLW) on the received signal will result. To prevent corruption of the received data, the PHY corrects for BLW and can receive the ANSI X3.263-1995 FDDI TP-PMD defined “killer packet” with no bit errors.

The 100M PLL generates multiple phases of the 125MHz clock. A multiplexer, controlled by the timing unit of the DSP, selects the optimum phase for sampling the data. This is used as the received recovered clock. This clock is used to extract the serial data from the received signal.

4.3.3 NRZI AND MLT-3 DECODING

The DSP generates the MLT-3 recovered levels that are fed to the MLT-3 converter. The MLT-3 is then converted to an NRZI data stream.

4.3.4 DESCRAMBLING

The descrambler performs an inverse function to the scrambler in the transmitter and also performs the Serial In Parallel Out (SIPO) conversion of the data.

During reception of IDLE (/I) symbols, the descrambler synchronizes its descrambler key to the incoming stream. Once synchronization is achieved, the descrambler locks on this key and is able to descramble incoming data.

Special logic in the descrambler ensures synchronization with the remote PHY by searching for IDLE symbols within a window of 4000 bytes (40 μ s). This window ensures that a maximum packet size of 1514 bytes, allowed by the IEEE 802.3 standard, can be received with no interference. If no IDLE-symbols are detected within this time-period, receive operation is aborted and the descrambler re-starts the synchronization process.

The descrambler can be bypassed by setting bit 0 of register 31.

4.3.5 ALIGNMENT

The de-scrambled signal is then aligned into 5-bit code-groups by recognizing the /J/K/ Start-of-Stream Delimiter (SSD) pair at the start of a packet. Once the code-word alignment is determined, it is stored and utilized until the next start of frame.

4.3.6 5B/4B DECODING

The 5-bit code-groups are translated into 4-bit data nibbles according to the 4B/5B table. The translated data is presented on the RXD[3:0] signal lines. The SSD, /J/K/, is translated to “0101 0101” as the first 2 nibbles of the MAC preamble. Reception of the SSD causes the PHY to assert the RX_DV signal, indicating that valid data is available on the RXD bus. Successive valid code-groups are translated to data nibbles. Reception of either the End of Stream Delimiter (ESD) consisting of the /T/R/ symbols, or at least two /I/ symbols causes the PHY to de-assert carrier sense and RX_DV.

These symbols are not translated into data.

The decoding process may be bypassed by clearing bit 6 of register 31. When the decoding is bypassed the 5th receive data bit is driven out on RX_ER/RXD4. Decoding may be bypassed only when the MAC interface is in MII mode.

4.3.7 RECEIVE DATA VALID SIGNAL

The Receive Data Valid signal (RX_DV) indicates that recovered and decoded nibbles are being presented on the RXD[3:0] outputs synchronous to RX_CLK. RX_DV becomes active after the /J/K/ delimiter has been recognized and RXD is aligned to nibble boundaries. It remains active until either the /T/R/ delimiter is recognized or link test indicates failure or SIGDET becomes false.

RX_DV is asserted when the first nibble of translated /J/K/ is ready for transfer over the Media Independent Interface (MII).

FIGURE 4-3: RELATIONSHIP BETWEEN RECEIVED DATA AND SOME MII SIGNALS

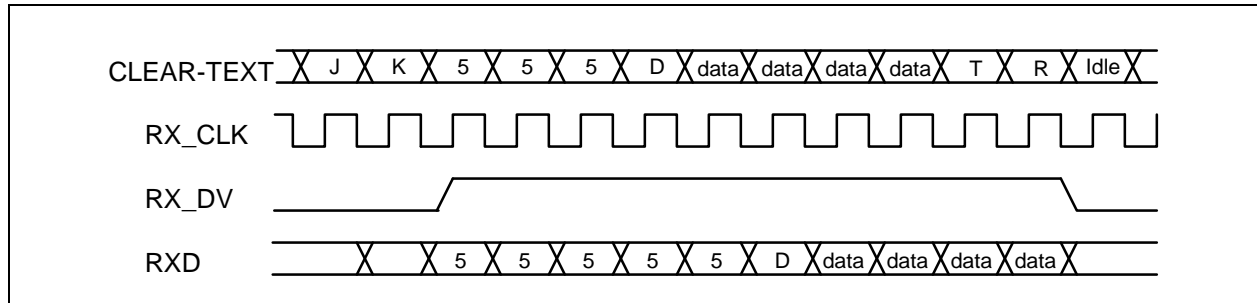

4.3.8 RECEIVER ERRORS

During a frame, unexpected code-groups are considered receive errors. Expected code groups are the DATA set (0 through F), and the /T/R/ (ESD) symbol pair. When a receive error occurs, the RX_ER signal is asserted and arbitrary data is driven onto the RXD[3:0] lines. Should an error be detected during the time that the /J/K/ delimiter is being decoded (bad SSD error), RX_ER is asserted true and the value '1110' is driven onto the RXD[3:0] lines. Note that the Valid Data signal is not yet asserted when the bad SSD error occurs.

4.3.9 100M RECEIVE DATA ACROSS THE MII

The 4-bit data nibbles are sent to the MII block. These data nibbles are clocked to the controller at a rate of 25MHz. The controller samples the data on the rising edge of RX_CLK. To ensure that the setup and hold requirements are met, the nibbles are clocked out of the PHY on the falling edge of RX_CLK. RX_CLK is the 25MHz output clock for the MII bus. It is recovered from the received data to clock the RXD bus. If there is no received signal, it is derived from the system reference clock (CLKIN).

When tracking the received data, RX_CLK has a maximum jitter of 0.8ns (provided that the jitter of the input clock, CLKIN, is below 100ps).

4.4 10Base-T Transmit

Data to be transmitted comes from the MAC layer controller. The 10Base-T transmitter receives 4-bit nibbles from the MII at a rate of 2.5MHz and converts them to a 10Mbps serial data stream. The data stream is then Manchester-encoded and sent to the analog transmitter, which drives a signal onto the twisted pair via the external magnetics.

The 10M transmitter uses the following blocks:

- MII (digital)
- TX 10M (digital)
- 10M Transmitter (analog)
- 10M PLL (analog)

4.4.1 10M TRANSMIT DATA ACROSS THE MII

The MAC controller drives the transmit data onto the TXD BUS. When the controller has driven TX_EN high to indicate valid data, the data is latched by the MII block on the rising edge of TX_CLK. The data is in the form of 4-bit wide 2.5MHz data.

LAN83C185

In order to comply with legacy 10Base-T MAC/Controllers, in Half-duplex mode the PHY loops back the transmitted data, on the receive path. This does not confuse the MAC/Controller since the COL signal is not asserted during this time. The PHY also supports the SQE (Heartbeat) signal. See [Section 5.4.2, "Collision Detect," on page 35](#) for more details.

4.4.2 MANCHESTER ENCODING

The 4-bit wide data is sent to the TX10M block. The nibbles are converted to a 10Mbps serial NRZI data stream. The 10M PLL locks onto the external clock or internal oscillator and produces a 20MHz clock. This is used to Manchester encode the NRZ data stream. When no data is being transmitted (TX_EN is low, the TX10M block outputs Normal Link Pulses (NLPs) to maintain communications with the remote link partner.

4.4.3 10M TRANSMIT DRIVERS

The Manchester encoded data is sent to the analog transmitter where it is shaped and filtered before being driven out as a differential signal across the TXP and TXN outputs.

4.5 10Base-T Receive

The 10Base-T receiver gets the Manchester- encoded analog signal from the cable via the magnetics. It recovers the receive clock from the signal and uses this clock to recover the NRZI data stream. This 10M serial data is converted to 4-bit data nibbles which are passed to the controller across the MII at a rate of 2.5MHz.

This 10M receiver uses the following blocks:

- Filter and SQUELCH (analog)
- 10M PLL (analog)
- RX 10M (digital)
- MII (digital)

4.5.1 10M RECEIVE INPUT AND SQUELCH

The Manchester signal from the cable is fed into the PHY (on inputs RXP and RXN) via 1:1 ratio magnetics. It is first filtered to reduce any out-of-band noise. It then passes through a SQUELCH circuit. The SQUELCH is a set of amplitude and timing comparators that normally reject differential voltage levels below 300mV and detect and recognize differential voltages above 585mV.

4.5.2 MANCHESTER DECODING

The output of the SQUELCH goes to the RX10M block where it is validated as Manchester encoded data. The polarity of the signal is also checked. If the polarity is reversed (local RXP is connected to RXN of the remote partner and vice versa), then this is identified and corrected. The reversed condition is indicated by the flag "XPOL", bit 4 in register 27. The 10M PLL is locked onto the received Manchester signal and from this, generates the received 20MHz clock. Using this clock, the Manchester encoded data is extracted and converted to a 10MHz NRZI data stream. It is then converted from serial to 4-bit wide parallel data.

The RX10M block also detects valid 10Base-T IDLE signals - Normal Link Pulses (NLPs) - to maintain the link.

4.5.3 10M RECEIVE DATA ACROSS THE MII

The 4 bit data nibbles are sent to the MII block. In MII mode, these data nibbles are valid on the rising edge of the 2.5 MHz RX_CLK.

4.5.4 JABBER DETECTION

Jabber is a condition in which a station transmits for a period of time longer than the maximum permissible packet length, usually due to a fault condition, that results in holding the TX_EN input for a long period. Special logic is used to detect the jabber state and abort the transmission to the line, within 45ms. Once TX_EN is deasserted, the logic resets the jabber condition.

Bit 1.1 indicates that a jabber condition was detected.

4.6 MAC Interface

The MII (Media Independent Interface) block is responsible for the communication with the controller. Special sets of hand-shake signals are used to indicate that valid received/transmitted data is present on the 4 bit receive/transmit bus.

4.6.1 MII

The MII includes 16 interface signals:

- transmit data - TXD[3:0]
- transmit strobe - TX_EN
- transmit clock - TX_CLK
- transmit error - TX_ER/TXD4
- receive data - RXD[3:0]
- receive strobe - RX_DV
- receive clock - RX_CLK
- receive error - RX_ER/RXD4
- collision indication - COL
- carrier sense - CRS

In MII mode, on the transmit path, the PHY drives the transmit clock, TX_CLK, to the controller. The controller synchronizes the transmit data to the rising edge of TX_CLK. The controller drives TX_EN high to indicate valid transmit data. The controller drives TX_ER high when a transmit error is detected.

On the receive path, the PHY drives both the receive data, RXD[3:0], and the RX_CLK signal. The controller clocks in the receive data on the rising edge of RX_CLK when the PHY drives RX_DV high. The PHY drives RX_ER high when a receive error is detected.

4.7 Auto-negotiation

The purpose of the Auto-negotiation function is to automatically configure the PHY to the optimum link parameters based on the capabilities of its link partner. Auto-negotiation is a mechanism for exchanging configuration information between two link-partners and automatically selecting the highest performance mode of operation supported by both sides. Auto-negotiation is fully defined in clause 28 of the IEEE 802.3 specification.

Once auto-negotiation has completed, information about the resolved link can be passed back to the controller via the Serial Management Interface (SMI). The results of the negotiation process are reflected in the Speed Indication bits in register 31, as well as the Link Partner Ability Register (Register 5).

The auto-negotiation protocol is a purely physical layer activity and proceeds independently of the MAC controller.

The advertised capabilities of the PHY are stored in register 4 of the SMI registers. The default advertised by the PHY is determined by user-defined on-chip signal options.

The following blocks are activated during an Auto-negotiation session:

- Auto-negotiation (digital)
- 100M ADC (analog)
- 100M PLL (analog)
- 100M equalizer/BLW/clock recovery (DSP)
- 10M SQUELCH (analog)
- 10M PLL (analog)
- 10M Transmitter (analog)

When enabled, auto-negotiation is started by the occurrence of one of the following events:

- Hardware reset
- Software reset
- Power-down reset
- Link status down
- Setting register 0, bit 9 high (auto-negotiation restart)

LAN83C185

On detection of one of these events, the PHY begins auto-negotiation by transmitting bursts of Fast Link Pulses (FLP). These are bursts of link pulses from the 10M transmitter. They are shaped as Normal Link Pulses and can pass uncorrupted down CAT-3 or CAT-5 cable. A Fast Link Pulse Burst consists of up to 33 pulses. The 17 odd-numbered pulses, which are always present, frame the FLP burst. The 16 even-numbered pulses, which may be present or absent, contain the data word being transmitted. Presence of a data pulse represents a “1”, while absence represents a “0”.

The data transmitted by an FLP burst is known as a “Link Code Word.” These are defined fully in IEEE 802.3 clause 28. In summary, the PHY advertises 802.3 compliance in its selector field (the first 5 bits of the Link Code Word). It advertises its technology ability according to the bits set in register 4 of the SMI registers.

There are 4 possible matches of the technology abilities. In the order of priority these are:

- 100M Full Duplex (Highest priority)
- 100M Half Duplex
- 10M Full Duplex
- 10M Half Duplex

If the full capabilities of the PHY are advertised (100M, Full Duplex), and if the link partner is capable of 10M and 100M, then auto-negotiation selects 100M as the highest performance mode. If the link partner is capable of Half and Full duplex modes, then auto-negotiation selects Full Duplex as the highest performance operation.

Once a capability match has been determined, the link code words are repeated with the acknowledge bit set. Any difference in the main content of the link code words at this time will cause auto-negotiation to re-start. Auto-negotiation will also re-start if not all of the required FLP bursts are received.

The capabilities advertised during auto-negotiation by the PHY are initially determined by the logic levels latched on the MODE[2:0] bus after reset completes. This bus can also be used to disable auto-negotiation on power-up.

Writing register 4 bits [8:5] allows software control of the capabilities advertised by the PHY. Writing register 4 does not automatically re-start auto-negotiation. Register 0, bit 9 must be set before the new abilities will be advertised. Auto-negotiation can also be disabled via software by clearing register 0, bit 12.

The LAN83C185 does not support “Next Page” capability.

4.7.1 PARALLEL DETECTION

If the LAN83C185 is connected to a device lacking the ability to auto-negotiate (i.e. no FLPs are detected), it is able to determine the speed of the link based on either 100M MLT-3 symbols or 10M Normal Link Pulses. In this case the link is presumed to be Half Duplex per the IEEE standard. This ability is known as “Parallel Detection. This feature ensures interoperability with legacy link partners. If a link is formed via parallel detection, then bit 0 in register 6 is cleared to indicate that the Link Partner is not capable of auto-negotiation. The controller has access to this information via the management interface. If a fault occurs during parallel detection, bit 4 of register 6 is set.

Register 5 is used to store the Link Partner Ability information, which is coded in the received FLPs. If the Link Partner is not auto-negotiation capable, then register 5 is updated after completion of parallel detection to reflect the speed capability of the Link Partner.

4.7.2 RE-STARTING AUTO-NEGOTIATION

Auto-negotiation can be re-started at any time by setting register 0, bit 9. Auto-negotiation will also re-start if the link is broken at any time. A broken link is caused by signal loss. This may occur because of a cable break, or because of an interruption in the signal transmitted by the Link Partner. Auto-negotiation resumes in an attempt to determine the new link configuration.

If the management entity re-starts Auto-negotiation by writing to bit 9 of the control register, the LAN83C185 will respond by stopping all transmission/receiving operations. Once the break_link_timer is done, in the Auto-negotiation state-machine (approximately 1200ms) the auto-negotiation will re-start. The Link Partner will have also dropped the link due to lack of a received signal, so it too will resume auto-negotiation.

4.7.3 DISABLING AUTO-NEGOTIATION

Auto-negotiation can be disabled by setting register 0, bit 12 to zero. The device will then force its speed of operation to reflect the information in register 0, bit 13 (speed) and register 0, bit 8 (duplex). The speed and duplex bits in register 0 should be ignored when auto-negotiation is enabled.

4.7.4 HALF VS. FULL DUPLEX

Half Duplex operation relies on the CSMA/CD (Carrier Sense Multiple Access / Collision Detect) protocol to handle network traffic and collisions. In this mode, the carrier sense signal, CRS, responds to both transmit and receive activity. In this mode, If data is received while the PHY is transmitting, a collision results.

In Full Duplex mode, the PHY is able to transmit and receive data simultaneously. In this mode, CRS responds only to receive activity. The CSMA/CD protocol does not apply and collision detection is disabled.

4.8 PHY Management Control

The Management Control module includes 3 blocks:

- Serial Management Interface (SMI)
- Management Registers Set
- Interrupt

4.8.1 SERIAL MANAGEMENT INTERFACE (SMI)

The Serial Management Interface is used to control the LAN83C185 and obtain its status. This interface supports registers 0 through 6 as required by Clause 22 of the 802.3 standard, as well as “vendor-specific” registers 16 to 31 allowed by the specification. Non-supported registers (7 to 15) will be read as hexadecimal “FFFF”.

At the system level there are 2 signals, MDIO and MDC where MDIO is bi-directional open-drain and MDC is the clock.

A special feature (enabled by register 17 bit 3) forces the PHY to disregard the PHY-Address in the SMI packet causing the PHY to respond to any address. This feature is useful in multi-PHY applications and in production testing, where the same register can be written in all the PHYs using a single write transaction.

The MDC signal is an aperiodic clock provided by the station management controller (SMC). The MDIO signal receives serial data (commands) from the controller SMC, and sends serial data (status) to the SMC. The minimum time between edges of the MDC is 160 ns. There is no maximum time between edges.

The minimum cycle time (time between two consecutive rising or two consecutive falling edges) is 400 ns. These modest timing requirements allow this interface to be easily driven by the I/O port of a microcontroller.

The data on the MDIO line is latched on the rising edge of the MDC. The frame structure and timing of the data is shown in [Figure 4-4](#) and [Figure 4-5](#).

LAN83C185

The timing relationships of the MDIO signals are further described in [Section 6.1, "Serial Management Interface \(SMI\) Timing,"](#) on page 41.

FIGURE 4-4: MDIO TIMING AND FRAME STRUCTURE - READ CYCLE

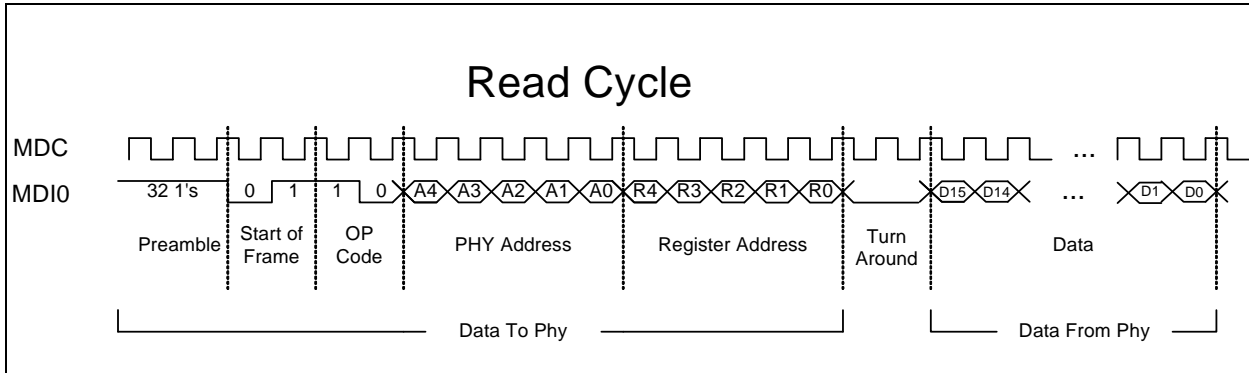
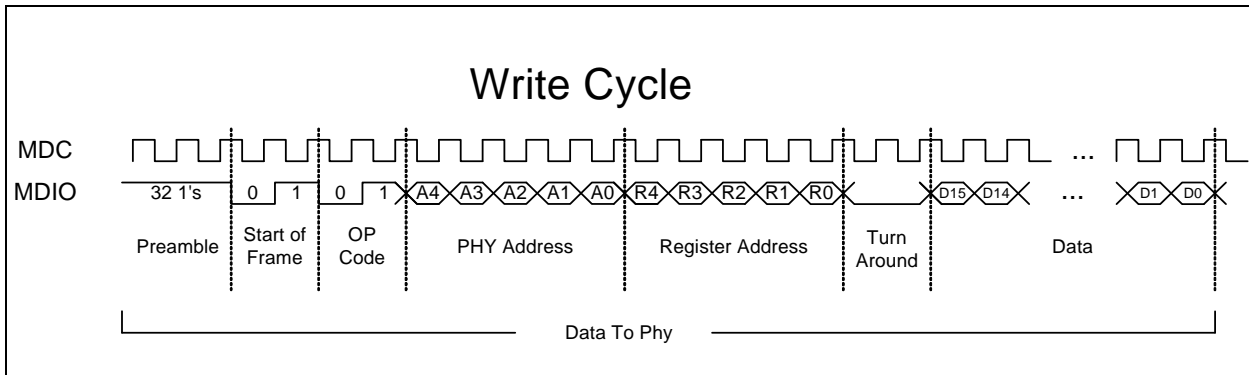

FIGURE 4-5: MDIO TIMING AND FRAME STRUCTURE - WRITE CYCLE



5.0 REGISTERS

TABLE 5-1: CONTROL REGISTER: REGISTER 0 (BASIC)

| | | | | | | | | | | | |
|-------|----------|--------------|------------|------------|---------|-------------|-------------|----------------|---|---|---|
| 15 | 14 | 13 | 12 | 11 | 10 | 9 | 8 | 7 | 6 | 5 | 4 |
| Reset | Loopback | Speed Select | A/N Enable | Power Down | Isolate | Restart A/N | Duplex Mode | Collision Test | | | |

TABLE 5-2: STATUS REGISTER: REGISTER 1 (BASIC)

| | | | | | | | | | | | | |
|------------|------------------------|------------------------|----------------------|----------------------|----------|--------------|---|--------------|-------------|---|---|---|
| 15 | 14 | 13 | 12 | 11 | 10 | 9 | 8 | 7 | 6 | 5 | 4 | 3 |
| 100Base-T4 | 100Base-TX Full Duplex | 100Base-TX Half Duplex | 10Base-T Full Duplex | 10Base-T Half Duplex | Reserved | A/N Complete | | Remote Fault | A/N Ability | | | |

TABLE 5-3: PHY ID 1 REGISTER: REGISTER 2 (EXTENDED)

| | | | | | | | | | | | | |
|---|----|----|----|----|----|---|---|---|---|---|---|---|
| 15 | 14 | 13 | 12 | 11 | 10 | 9 | 8 | 7 | 6 | 5 | 4 | 3 |
| PHY ID Number (Bits 3-18 of the Organizationally Unique Identifier - OUI) | | | | | | | | | | | | |

TABLE 5-4: PHY ID 2 REGISTER: REGISTER 3 (EXTENDED)

| | | | | | | | | | | | | |
|--|----|----|----|----|----|---------------------------|---|---|---|---|---|--------------|
| 15 | 14 | 13 | 12 | 11 | 10 | 9 | 8 | 7 | 6 | 5 | 4 | 3 |
| PHY ID Number (Bits 19-24 of the Organizationally Unique Identifier - OUI) | | | | | | Manufacturer Model Number | | | | | | Manufacturer |

TABLE 5-5: AUTO-NEGOTIATION ADVERTISEMENT: REGISTER 4 (EXTENDED)

| | | | | | | | | | | | | |
|-----------|----------|--------------|----------|---------------------------|----------------------------|------------|------------------------|------------------------|----------------------|-----------------|---|---|
| 15 | 14 | 13 | 12 | 11 | 10 | 9 | 8 | 7 | 6 | 5 | 4 | 3 |
| Next Page | Reserved | Remote Fault | Reserved | Symmetric Pause Operation | Asymmetric Pause Operation | 100Base-T4 | 100Base-TX Full Duplex | 100Base-TX Full Duplex | 10Base-T Full Duplex | 10Base-T Duplex | | |

TABLE 5-6: AUTO-NEGOTIATION LINK PARTNER BASE PAGE ABILITY REGISTER: REGISTER 5 (EXTENDED)

| | | | | | | | | | | | | |
|-----------|-------------|--------------|----------|----------|-------|------------|------------------------|------------|----------------------|----------|---|----|
| 15 | 14 | 13 | 12 | 11 | 10 | 9 | 8 | 7 | 6 | 5 | 4 | IE |
| Next Page | Acknowledge | Remote Fault | Reserved | Reserved | Pause | 100Base-T4 | 100Base-TX Full Duplex | 100Base-TX | 10Base-T Full Duplex | 10Base-T | | |

TABLE 5-7: AUTO-NEGOTIATION EXPANSION REGISTER: REGISTER 6 (EXTENDED)

| | | | | | | | | | | | | | |
|----------|----|----|----|----|----|---|---|---|---|---|---|-----------------------------|----------------|
| 15 | 14 | 13 | 12 | 11 | 10 | 9 | 8 | 7 | 6 | 5 | 4 | 3 | 2 |
| | | | | | | | | | | | | Link Partner Next Page Able | Next Page Able |
| Reserved | | | | | | | | | | | | Parallel Detect Fault | |

TABLE 5-8: AUTO-NEGOTIATION LINK PARTNER NEXT PAGE TRANSMIT REGISTER: REGISTER 7 (EXTENDED)

| | | | | | | | | | | | | |
|----------|----|----|----|----|----|---|---|---|---|---|---|---|
| 15 | 14 | 13 | 12 | 11 | 10 | 9 | 8 | 7 | 6 | 5 | 4 | 3 |
| Reserved | | | | | | | | | | | | |

Note: Next Page capability is not supported.

TABLE 5-9: REGISTER 8 (EXTENDED)

| | | | | | | | | | | | | |
|---------------|----|----|----|----|----|---|---|---|---|---|---|---|
| 15 | 14 | 13 | 12 | 11 | 10 | 9 | 8 | 7 | 6 | 5 | 4 | 3 |
| IEEE Reserved | | | | | | | | | | | | |

TABLE 5-10: REGISTER 9 (EXTENDED)

| | | | | | | | | | | | | |
|---------------|----|----|----|----|----|---|---|---|---|---|---|---|
| 15 | 14 | 13 | 12 | 11 | 10 | 9 | 8 | 7 | 6 | 5 | 4 | 3 |
| IEEE Reserved | | | | | | | | | | | | |

TABLE 5-11: REGISTER 10 (EXTENDED)

| | | | | | | | | | | | | |
|---------------|----|----|----|----|----|---|---|---|---|---|---|---|
| 15 | 14 | 13 | 12 | 11 | 10 | 9 | 8 | 7 | 6 | 5 | 4 | 3 |
| IEEE Reserved | | | | | | | | | | | | |

TABLE 5-11: REGISTER 11 (EXTENDED)

| | | | | | | | | | | | | |
|---------------|----|----|----|----|----|---|---|---|---|---|---|---|
| 15 | 14 | 13 | 12 | 11 | 10 | 9 | 8 | 7 | 6 | 5 | 4 | 3 |
| IEEE Reserved | | | | | | | | | | | | |

TABLE 5-12: REGISTER 12 (EXTENDED)

| | | | | | | | | | | | | |
|---------------|----|----|----|----|----|---|---|---|---|---|---|---|
| 15 | 14 | 13 | 12 | 11 | 10 | 9 | 8 | 7 | 6 | 5 | 4 | 3 |
| IEEE Reserved | | | | | | | | | | | | |

TABLE 5-13: REGISTER 13 (EXTENDED)

| | | | | | | | | | | | | |
|---------------|----|----|----|----|----|---|---|---|---|---|---|---|
| 15 | 14 | 13 | 12 | 11 | 10 | 9 | 8 | 7 | 6 | 5 | 4 | 3 |
| IEEE Reserved | | | | | | | | | | | | |

TABLE 5-14: REGISTER 14 (EXTENDED)

| | | | | | | | | | | | | |
|---------------|----|----|----|----|----|---|---|---|---|---|---|---|
| 15 | 14 | 13 | 12 | 11 | 10 | 9 | 8 | 7 | 6 | 5 | 4 | 3 |
| IEEE Reserved | | | | | | | | | | | | |

TABLE 5-15: REGISTER 15 (EXTENDED)

| | | | | | | | | | | | | |
|---------------|----|----|----|----|----|---|---|---|---|---|---|---|
| 15 | 14 | 13 | 12 | 11 | 10 | 9 | 8 | 7 | 6 | 5 | 4 | 3 |
| IEEE Reserved | | | | | | | | | | | | |

TABLE 5-17: SILICON REVISION REGISTER 16: VENDOR-SPECIFIC

| | | | | | | | | | | | | | |
|----------|----|----|----|----|----|------------------|---|---|---|---|---|----------|----------|
| 15 | 14 | 13 | 12 | 11 | 10 | 9 | 8 | 7 | 6 | 5 | 4 | 3 | Reserved |
| Reserved | | | | | | Silicon Revision | | | | | | Reserved | |

TABLE 5-18: MODE CONTROL/ STATUS REGISTER 17: VENDOR-SPECIFIC

| | | | | | | | | | | | | | |
|----------|---------|-----------|----------|---------|---------|-------------|---------|----------|----------|---------|------------|---|----------|
| 15 | 14 | 13 | 12 | 11 | 10 | 9 | 8 | 7 | 6 | 5 | 4 | 3 | Reserved |
| Reserved | FASTRIP | EDPWRDOWN | Reserved | LOWSQEN | MDPREBP | FARLOOPBACK | FASTEST | Reserved | REFCLKEN | PHYADBP | Go Lib Sta | | |

TABLE 5-19: SPECIAL MODES REGISTER 18: VENDOR-SPECIFIC

| | | | | | | | | | | | | |
|---------|------------|-------|------|----------|-------|-------|------|---|---|---|---|---|
| 15 | 14 | 13 | 12 | 11 | 10 | 9 | 8 | 7 | 6 | 5 | 4 | 3 |
| MIIMODE | CLKSELFREQ | DSPBP | SQBP | Reserved | PLLBP | ADCBP | MODE | | | | | |

TABLE 5-20: RESERVED REGISTER 19: VENDOR-SPECIFIC

| | | | | | | | | | | | | |
|----------|----|----|----|----|----|---|---|---|---|---|---|---|
| 15 | 14 | 13 | 12 | 11 | 10 | 9 | 8 | 7 | 6 | 5 | 4 | 3 |
| Reserved | | | | | | | | | | | | |

TABLE 5-21: TSTCNTL REGISTER 20: VENDOR-SPECIFIC

| | | | | | | | | | | | | | |
|------|-------|----------|-----------|--------------|----|---|---|---|---|---|---|---|-------|
| 15 | 14 | 13 | 12 | 11 | 10 | 9 | 8 | 7 | 6 | 5 | 4 | 3 | WRITE |
| READ | WRITE | Reserved | TEST MODE | READ ADDRESS | | | | | | | | | |

TABLE 5-22: TSTREAD2 REGISTER 21: VENDOR-SPECIFIC

| | | | | | | | | | | | | |
|-----------|----|----|----|----|----|---|---|---|---|---|---|---|
| 15 | 14 | 13 | 12 | 11 | 10 | 9 | 8 | 7 | 6 | 5 | 4 | 3 |
| READ_DATA | | | | | | | | | | | | |

TABLE 5-23: TSTREAD1 REGISTER 22: VENDOR-SPECIFIC

| | | | | | | | | | | | | |
|-----------|----|----|----|----|----|---|---|---|---|---|---|---|
| 15 | 14 | 13 | 12 | 11 | 10 | 9 | 8 | 7 | 6 | 5 | 4 | 3 |
| READ_DATA | | | | | | | | | | | | |

TABLE 5-24: TSTWRITE REGISTER 23: VENDOR-SPECIFIC

| | | | | | | | | | | | | |
|------------|----|----|----|----|----|---|---|---|---|---|---|---|
| 15 | 14 | 13 | 12 | 11 | 10 | 9 | 8 | 7 | 6 | 5 | 4 | 3 |
| WRITE_DATA | | | | | | | | | | | | |

TABLE 5-25: REGISTER 24: VENDOR-SPECIFIC

| | | | | | | | | | | | | |
|----------|----|----|----|----|----|---|---|---|---|---|---|---|
| 15 | 14 | 13 | 12 | 11 | 10 | 9 | 8 | 7 | 6 | 5 | 4 | 3 |
| Reserved | | | | | | | | | | | | |

TABLE 5-26: REGISTER 25: VENDOR-SPECIFIC

| | | | | | | | | | | | | |
|----------|----|----|----|----|----|---|---|---|---|---|---|---|
| 15 | 14 | 13 | 12 | 11 | 10 | 9 | 8 | 7 | 6 | 5 | 4 | 3 |
| Reserved | | | | | | | | | | | | |

TABLE 5-27: REGISTER 26: VENDOR-SPECIFIC

| | | | | | | | | | | | | |
|----------|----|----|----|----|----|---|---|---|---|---|---|---|
| 15 | 14 | 13 | 12 | 11 | 10 | 9 | 8 | 7 | 6 | 5 | 4 | 3 |
| Reserved | | | | | | | | | | | | |

TABLE 5-28: SPECIAL CONTROL/STATUS INDICATIONS REGISTER 27: VENDOR-SPECIFIC

| | | | | | | | | | | | | |
|----------|----|------------|--------|----------|----------|----------|----------|----------|----------|----------|----------|------|
| 15 | 14 | 13 | 12 | 11 | 10 | 9 | 8 | 7 | 6 | 5 | 4 | |
| Reserved | | SWRST_FAST | SQEOFF | VCOFF_LP | Reserved | Reserved | Reserved | Reserved | Reserved | Reserved | Reserved | XPOL |

TABLE 5-29: SPECIAL INTERNAL TESTABILITY CONTROL REGISTER 28: VENDOR-SPECIFIC

| | | | | | | | | | | | | |
|----------|----|----|----|----|----|---|---|---|---|---|---|---|
| 15 | 14 | 13 | 12 | 11 | 10 | 9 | 8 | 7 | 6 | 5 | 4 | 3 |
| Reserved | | | | | | | | | | | | |

TABLE 5-30: INTERRUPT SOURCE FLAGS REGISTER 29: VENDOR-SPECIFIC

| | | | | | | | | | | | | | |
|----------|----|----------|----|----------|----|----------|---|------|------|------|------|------|------|
| 15 | 14 | 13 | 12 | 11 | 10 | 9 | 8 | 7 | 6 | 5 | 4 | 3 | 2 |
| Reserved | | Reserved | | Reserved | | Reserved | | INT7 | INT6 | INT5 | INT4 | INT3 | INT2 |

TABLE 5-31: INTERRUPT MASK REGISTER 30: VENDOR-SPECIFIC

| | | | | | | | | | | | | |
|-----------|----|----|----|----|----|---|---|---|---|---|---|---|
| 15 | 14 | 13 | 12 | 11 | 10 | 9 | 8 | 7 | 6 | 5 | 4 | 3 |
| Reserved | | | | | | | | | | | | |
| Mask Bits | | | | | | | | | | | | |

TABLE 5-32: PHY SPECIAL CONTROL/STATUS REGISTER 31: VENDOR-SPECIFIC

| | | | | | | | | | | | | | |
|----------|----|----------|----|----------|----|----------|---|------|------|------|-------------|----------|------------------|
| 15 | 14 | 13 | 12 | 11 | 10 | 9 | 8 | 7 | 6 | 5 | 4 | 3 | 2 |
| Reserved | | Reserved | | Reserved | | Reserved | | GPO0 | GPO1 | GPO2 | Enable 4B5B | Reserved | Speed Indication |

5.1 SMI Register Mapping

The following registers are supported (register numbers are in decimal):

TABLE 5-33: SMI REGISTER MAPPING

| Register # | Description | Group |
|------------|---|-----------------|
| 0 | Basic Control Register | Basic |
| 1 | Basic Status Register | Basic |
| 2 | PHY Identifier 1 | Extended |
| 3 | PHY Identifier 2 | Extended |
| 4 | Auto-Negotiation Advertisement Register | Extended |
| 5 | Auto-Negotiation Link Partner Ability Register | Extended |
| 6 | Auto-Negotiation Expansion Register | Extended |
| 16 | Silicon Revision Register | Vendor-specific |
| 17 | Mode Control/Status Register | Vendor-specific |
| 18 | Special Modes | Vendor-specific |
| 20 | TSTCNTL – Testability/Configuration Control | Vendor-specific |
| 21 | TSTREAD1 – Testability data Read for LSB | Vendor-specific |
| 22 | TSTREAD2 – Testability data Read for MSB | Vendor-specific |
| 23 | TSTWRITE – Testability/Configuration data Write | Vendor-specific |
| 27 | Control / Status Indication Register | Vendor-specific |
| 28 | Special internal testability controls | Vendor-specific |
| 29 | Interrupt Source Register | Vendor-specific |
| 30 | Interrupt Mask Register | Vendor-specific |
| 31 | PHY Special Control/Status Register | Vendor-specific |

5.2 SMI Register Format

The mode key is as follows:

- RW = read/write,
- SC = self clearing,
- WO = write only,
- RO = read only,
- LH = latch high, clear on read of register,
- LL = latch low, clear on read of register,
- NASR = Not Affected by Software Reset

TABLE 5-34: REGISTER 0 - BASIC CONTROL

| Address | Name | Description | Mode | Default |
|---------|-------------------------|---|-----------|----------------------------|
| 0.15 | Reset | 1 = software reset. Bit is self-clearing. For best results, when setting this bit do not set other bits in this register. | RW/ SC | 0 |
| 0.14 | Loopback | 1 = loopback mode, 0 = normal operation | RW | 0 |
| 0.13 | Speed Select | 1 = 100Mbps, 0 = 10Mbps. Ignored if Auto Negotiation is enabled (0.12 = 1). | RW | Set by MODE[2:0] bus |
| 0.12 | Auto-Negotiation Enable | 1 = enable auto-negotiate process (overrides 0.13 and 0.8) 0 = disable auto-negotiate process | RW | Set by MODE[2:0] bus |

LAN83C185

TABLE 5-34: REGISTER 0 - BASIC CONTROL (CONTINUED)

| Address | Name | Description | Mode | Default |
|---------|------------------------|--|-----------|----------------------------|
| 0.11 | Power Down | 1 = General power down mode, 0 = normal operation | RW | 0 |
| 0.10 | Isolate | 1 = electrical isolation of PHY from MII 0 = normal operation | RW | Set by MODE[2:0] bus |
| 0.9 | Restart Auto-Negotiate | 1 = restart auto-negotiate process 0 = normal operation. Bit is self-clearing. | RW/ SC | 0 |
| 0.8 | Duplex Mode | 1 = Full duplex, 0 = Half duplex. Ignored if Auto Negotiation is enabled (0.12 = 1). | RW | Set by MODE[2:0] bus |
| 0.7 | Collision Test | 1 = enable COL test, 0 = disable COL test | RW | 0 |
| 0.6:0 | Reserved | | RO | 0 |

TABLE 5-35: REGISTER 1 - BASIC STATUS

| Address | Name | Description | Mode | Default |
|---------|-------------------------|--|-----------|---------|
| 1.15 | 100Base-T4 | 1 = T4 able, 0 = no T4 ability | RO | 0 |
| 1.14 | 100Base-TX Full Duplex | 1 = TX with full duplex, 0 = no TX full duplex ability | RO | 1 |
| 1.13 | 100Base-TX Half Duplex | 1 = TX with half duplex, 0 = no TX half duplex ability | RO | 1 |
| 1.12 | 10Base-T Full Duplex | 1 = 10Mbps with full duplex 0 = no 10Mbps with full duplex ability | RO | 1 |
| 1.11 | 10Base-T Half Duplex | 1 = 10Mbps with half duplex 0 = no 10Mbps with half duplex ability | RO | 1 |
| 1.10:6 | Reserved | | | |
| 1.5 | Auto-Negotiate Complete | 1 = auto-negotiate process completed 0 = auto-negotiate process not completed | RO | 0 |
| 1.4 | Remote Fault | 1 = remote fault condition detected 0 = no remote fault | RO/ LH | 0 |
| 1.3 | Auto-Negotiate Ability | 1 = able to perform auto-negotiation function 0 = unable to perform auto-negotiation function | RO | 1 |
| 1.2 | Link Status | 1 = link is up, 0 = link is down | RO/ LL | 0 |
| 1.1 | Jabber Detect | 1 = jabber condition detected 0 = no jabber condition detected | RO/ LH | 0 |
| 1.0 | Extended Capabilities | 1 = supports extended capabilities registers 0 = does not support extended capabilities registers | RO | 1 |

TABLE 5-36: REGISTER 2 - PHY IDENTIFIER 1

| Address | Name | Description | Mode | Default |
|---------|---------------|---|------|---------|
| 2.15:0 | PHY ID Number | Assigned to the 3rd through 18th bits of the Organizationally Unique Identifier (OUI), respectively. OUI=00800Fh | RW | 0007h |

TABLE 5-37: REGISTER 3 - PHY IDENTIFIER 2

| Address | Name | Description | Mode | Default |
|---------|-----------------|--|------|---------|
| 3.15:10 | PHY ID Number | Assigned to the 19 th through 24 th bits of the OUI. | RW | C0h |
| 3.9:4 | Model Number | Six-bit manufacturer's model number. | RW | 0Ah |
| 3.3:0 | Revision Number | Four-bit manufacturer's revision number. | RW | 1h |

TABLE 5-38: REGISTER 4 - AUTO NEGOTIATION ADVERTISEMENT

| Address | Name | Description | Mode | Default |
|---------|------------------------|--|------|----------------------|
| 4.15 | Next Page | 1 = next page capable, 0 = no next page ability This Phy does not support next page ability. | RO | 0 |
| 4.14 | Reserved | | RO | 0 |
| 4.13 | Remote Fault | 1 = remote fault detected, 0 = no remote fault | RW | 0 |
| 4.12 | Reserved | | | |
| 4.11:10 | Pause Operation | 00 = No PAUSE 01 = Asymmetric PAUSE toward link partner 10 = Symmetric PAUSE 11 = Both Symmetric PAUSE and Asymmetric PAUSE toward local device | R/W | 00 |
| 4.9 | 100Base-T4 | 1 = T4 able, 0 = no T4 ability This Phy does not support 100Base-T4. | RO | 0 |
| 4.8 | 100Base-TX Full Duplex | 1 = TX with full duplex, 0 = no TX full duplex ability | RW | Set by MODE[2:0] bus |
| 4.7 | 100Base-TX | 1 = TX able, 0 = no TX ability | RW | 1 |
| 4.6 | 10Base-T Full Duplex | 1 = 10Mbps with full duplex 0 = no 10Mbps with full duplex ability | RW | Set by MODE[2:0] bus |
| 4.5 | 10Base-T | 1 = 10Mbps able, 0 = no 10Mbps ability | RW | Set by MODE[2:0] bus |
| 4.4:0 | Selector Field | [00001] = IEEE 802.3 | RW | 00001 |

TABLE 5-39: REGISTER 5 - AUTO NEGOTIATION LINK PARTNER ABILITY

| Address | Name | Description | Mode | Default |
|---------|-----------------|--|------|---------|
| 5.15 | Next Page | 1 = "Next Page" capable, 0 = no "Next Page" ability This Phy does not support next page ability. | RO | 0 |
| 5.14 | Acknowledge | 1 = link code word received from partner 0 = link code word not yet received | RO | 0 |
| 5.13 | Remote Fault | 1 = remote fault detected, 0 = no remote fault | RO | 0 |
| 5.12:11 | Reserved | | RO | 0 |
| 5.10 | Pause Operation | 1 = Pause Operation is supported by remote MAC, 0 = Pause Operation is not supported by remote MAC | RO | 0 |

LAN83C185

TABLE 5-39: REGISTER 5 - AUTO NEGOTIATION LINK PARTNER ABILITY (CONTINUED)

| Address | Name | Description | Mode | Default |
|---------|------------------------|---|------|---------|
| 5.9 | 100Base-T4 | 1 = T4 able, 0 = no T4 ability. This Phy does not support T4 ability. | RO | 0 |
| 5.8 | 100Base-TX Full Duplex | 1 = TX with full duplex, 0 = no TX full duplex ability | RO | 0 |
| 5.7 | 100Base-TX | 1 = TX able, 0 = no TX ability | RO | 0 |
| 5.6 | 10Base-T Full Duplex | 1 = 10Mbps with full duplex 0 = no 10Mbps with full duplex ability | RO | 0 |
| 5.5 | 10Base-T | 1 = 10Mbps able, 0 = no 10Mbps ability | RO | 0 |
| 5.4:0 | Selector Field | [00001] = IEEE 802.3 | RO | 00001 |

TABLE 5-40: REGISTER 6 - AUTO NEGOTIATION EXPANSION

| Address | Name | Description | Mode | Default |
|---------|------------------------------------|--|-----------|---------|
| 6.15:5 | Reserved | | RO | 0 |
| 6.4 | Parallel Detection Fault | 1 = fault detected by parallel detection logic 0 = no fault detected by parallel detection logic | RO/ LH | 0 |
| 6.3 | Link Partner Next Page Able | 1 = link partner has next page ability 0 = link partner does not have next page ability | RO | 0 |
| 6.2 | Next Page Able | 1 = local device has next page ability 0 = local device does not have next page ability | RO | 0 |
| 6.1 | Page Received | 1 = new page received 0 = new page not yet received | RO/ LH | 0 |
| 6.0 | Link Partner Auto-Negotiation Able | 1 = link partner has auto-negotiation ability 0 = link partner does not have auto-negotiation ability | RO | 0 |

TABLE 5-41: REGISTER 16 - SILICON REVISION

| Address | Name | Description | Mode | Default |
|----------|------------------|---------------------------------------|------|---------|
| 16.15:10 | Reserved | | RO | 0 |
| 16.9:6 | Silicon Revision | Four-bit silicon revision identifier. | RO | 0001 |
| 16.5:0 | Reserved | | RO | 0 |

TABLE 5-42: REGISTER 17 - MODE CONTROL/STATUS

| Address | Name | Description | Mode | Default |
|---------|-----------|--|-------------|---------|
| 17.15 | Reserved | Write as 0; ignore on read. | RW | 0 |
| 17.14 | FASTRIP | 10Base-T fast mode: 0 = normal operation 1 = Reserved Must be left at 0 | RW, NASR | 0 |
| 17.13 | EDPWRDOWN | Enable the Energy Detect Power-Down mode: 0 = Energy Detect Power-Down is disabled 1 = Energy Detect Power-Down is enabled | RW | 0 |
| 17.12 | Reserved | Write as 0, ignore on read | RW | 0 |

TABLE 5-42: REGISTER 17 - MODE CONTROL/STATUS (CONTINUED)

| Address | Name | Description | Mode | Default |
|---------|------------------------|---|------|---------|
| 17.11 | LOWSQEN | The Low_Squelch signal is equal to LOWSQEN AND EDPWRDOWN. Low_Squelch = 1 implies a lower threshold (more sensitive). Low_Squelch = 0 implies a higher threshold (less sensitive). | RW | 0 |
| 17.10 | MDPREBP | Management Data Preamble Bypass: 0 – detect SMI packets with Preamble 1 – detect SMI packets without preamble | RW | 0 |
| 17.9 | Reserved | Reserved Must be left at 0 | RW | 0 |
| 17.8 | FASTEST | Auto-Negotiation Test Mode 0 = normal operation 1 = activates test mode | RW | 0 |
| 17.7:5 | Reserved | Write as 0, ignore on read. | | |
| 17.4 | Reserved | Reserved Must be left at 0 | RW | 0 |
| 17.3 | PHYADBP | 1 = PHY disregards PHY address in SMI access write. | RW | 0 |
| 17.2 | Force Good Link Status | 0 = normal operation; 1 = force 100TX- link active; This bit should be set only during lab testing | RW | 0 |
| 17.1 | ENERGYON | ENERGYON – indicates whether energy is detected on the line (see Section 5.4.5.2, "Energy Detect Power-Down," on page 35); it goes to "0" if no valid energy is detected within 256ms. Reset to "1" by hardware reset, unaffected by SW reset. | RO | 1 |
| 17.0 | Reserved | Write as "0". Ignore on read. | RW | 0 |

TABLE 5-43: REGISTER 18 - SPECIAL MODES

| Address | Name | Description | Mode | Default |
|----------|------------|--|-------------|---------|
| 18.15:14 | MIIMODE | MII Mode: set the mode of the MII: 0 – MII interface. 1 – Reserved | RW, NASR | |
| 18.13 | CLKSELFREQ | Clock In Selected Frequency. Set the requested input clock frequency. This bit drives signal that goes to external logic of the Phy and select the desired frequency of the input clock: 0 – the clock frequency is 25MHz 1 – Reserved | RO, NASR | |
| 18.12 | DSPBP | DSP Bypass mode. Used only in special lab tests. | RW, NASR | 0 |
| 18.11 | SQBP | SQUELCH Bypass mode. | RW, NASR | 0 |
| 18.10 | Reserved | | RW, NASR | |
| 18.9 | PLLBP | PLL Bypass mode. | RW, NASR | |
| 18.8 | ADCBP | ADC Bypass mode. | RW, NASR | |

LAN83C185

TABLE 5-43: REGISTER 18 - SPECIAL MODES (CONTINUED)

| Address | Name | Description | Mode | Default |
|---------|-------|--|-------------|---------|
| 18.7:5 | MODE | PHY Mode of operation. Refer to Section 5.4.9.2, "Mode Bus – MODE[2:0]" , on page 38 for more details. | RW, NASR | |
| 18.4:0 | PHYAD | PHY Address. The PHY Address is used for the SMI address and for the initialization of the Cipher (Scrambler) key. Refer to Section 5.4.9.1, "Physical Address Bus - PHYAD[4:0]" , on page 37 for more details. | RW, NASR | PHYAD |

TABLE 5-44: REGISTER 20 - TSTCNTL

| Address | Name | Description | Mode | Default |
|----------|---------------|---|------|---------|
| 20.15 | READ | When setting this bit to "1", the content of the register that is selected by the READ ADDRESS will be latched to the TSTREAD1/2 registers. This bit is self-cleared. | RW | 0 |
| 20.14 | WRITE | When setting this bit to "1", the register that is selected by the WRITE ADDRESS is going to be written with the data from the TSTWRITE register. This bit is self-cleared. | RW | 0 |
| 20.13:11 | Reserved | | | |
| 20.10 | TEST MODE | Enable the Testability/Configuration mode: 0 - Testability/Configuration mode disabled 1 - Testability/Configuration mode enabled | RW | 0 |
| 20.9:5 | READ ADDRESS | The address of the Testability/Configuration register that will be latched into the TSTREAD1 and TSTREAD2 registers | RW | 0 |
| 20.4:0 | WRITE ADDRESS | The address of the Testability/Configuration register that will be written. | RW | 0 |

TABLE 5-45: REGISTER 21 - TSTREAD1

| Address | Name | Description | Mode | Default |
|---------|-----------|--|------|---------|
| 21.15:0 | READ_DATA | When reading registers with a size of less than 16 bits, this register contains the register data, starting from bit 0. When reading registers with a size of more than 16 bits, this register contains the less significant 16 bits of the register data. | RO | 0 |

TABLE 5-46: REGISTER 22 - TSTREAD2

| Address | Name | Description | Mode | Default |
|---------|-----------|---|------|---------|
| 22.15:0 | READ_DATA | When reading registers with a size of less than 16 bits, this register clears to zeros. When reading registers with a size of more than 16 bits, this register contains the most significant bits of the register data, starting from the 16 th bit. | RO | 0 |

TABLE 5-47: REGISTER 23 - TSTWRITE

| Address | Name | Description | Mode | Default |
|---------|------------|--|------|---------|
| 23.15:0 | WRITE_DATA | This field contains the data that will be written to a specific register on the "Programming" transaction. | RW | 0 |

TABLE 5-48: REGISTER 27 - SPECIAL CONTROL/STATUS INDICATIONS

| Address | Name | Description | Mode | Default |
|----------|------------|--|-------------|---------|
| 27.15:13 | Reserved | | RW | 0 |
| 27.12 | SWRST_FAST | 1 = Accelerates SW reset counter from 256 ms to 10 us for production testing. | RW | 0 |
| 27.11 | SQEOFF | Disable the SQE test (Heartbeat): 0 - SQE test is enabled. 1 - SQE test is disabled. | RW, NASR | 0 |
| 27.10 | VCOOFF_LP | Forces the Receive PLL 10M to lock on the reference clock at all times: 0 - Receive PLL 10M can lock on reference or line as needed (normal operation) 1 - Receive PLL 10M is locked on the reference clock. In this mode 10M data packets cannot be received. | RW, NASR | 0 |
| 27.9 | Reserved | Write as 0. Ignore on read. | RW | 0 |
| 27.8 | Reserved | Write as 0. Ignore on read. | RW | 0 |
| 27.7 | Reserved | Write as 0. Ignore on read. | RW | 0 |
| 27.6 | Reserved | Write as 0. Ignore on read. | RW | 0 |
| 27.5 | Reserved | Write as 0. Ignore on read. | RW | |
| 27.4 | XPOL | Polarity state of the 10Base-T: 0 - Normal polarity 1 - Reversed polarity | RO | 0 |
| 27.3:0 | AUTONEGS | Auto-negotiation "ARB" State-machine state | RO | 1011 |

TABLE 5-49: REGISTER 28 - SPECIAL INTERNAL TESTABILITY CONTROLS

| Address | Name | Description | Mode | Default |
|---------|----------|--|------|---------|
| 28.15:0 | Reserved | Do not write to this register. Ignore on read. | RW | N/A |

TABLE 5-50: REGISTER 29 - INTERRUPT SOURCE FLAGS

| Address | Name | Description | Mode | Default |
|---------|----------|--|-----------|---------|
| 29.15:8 | Reserved | Ignore on read. | RO/ LH | 0 |
| 29.7 | INT7 | 1 = ENERGYON generated 0 = not source of interrupt | RO/ LH | 0 |
| 29.6 | INT6 | 1 = Auto-Negotiation complete 0 = not source of interrupt | RO/ LH | 0 |
| 29.5 | INT5 | 1 = Remote Fault Detected 0 = not source of interrupt | RO/ LH | 0 |
| 29.4 | INT4 | 1 = Link Down (link status negated) 0 = not source of interrupt | RO/ LH | 0 |
| 29.3 | INT3 | 1 = Auto-Negotiation LP Acknowledge 0 = not source of interrupt | RO/ LH | 0 |
| 29.2 | INT2 | 1 = Parallel Detection Fault 0 = not source of interrupt | RO/ LH | 0 |
| 29.1 | INT1 | 1 = Auto-Negotiation Page Received 0 = not source of interrupt | RO/ LH | 0 |
| 29.0 | Reserved | | RO/ LH | 0 |

LAN83C185

TABLE 5-51: REGISTER 30 - INTERRUPT MASK

| Address | Name | Description | Mode | Default |
|---------|-----------|---|------|---------|
| 30.15:8 | Reserved | Write as 0; ignore on read. | RO | 0 |
| 30.7:0 | Mask Bits | 1 = interrupt source is enabled 0 = interrupt source is masked | RW | 0 |

TABLE 5-52: REGISTER 31 - PHY SPECIAL CONTROL/STATUS

| Address | Name | Description | Mode | Default |
|----------|------------------|---|------|---------|
| 31.15 | Reserved | Do not write to this register. Ignore on read. | RW | 0 |
| 31.14 | Reserved | | | |
| 31.13 | Special | Must be set to 0 | RW | 0 |
| 31.12 | Autodone | Auto-negotiation done indication: 0 = Auto-negotiation is not done or disabled (or not active) 1 = Auto-negotiation is done | RO | 0 |
| 31.11:10 | Reserved | | RW | 0 |
| 31.9:7 | GPO[2:0] | General Purpose Output connected to signals GPO[2:0] | RW | 0 |
| 31.6 | Enable 4B5B | 0 = Bypass encoder/decoder. 1 = enable 4B5B encoding/decoding. MAC Interface must be configured in MII mode. | RW | 1 |
| 31.5 | Reserved | Write as 0, ignore on Read. | RW | 0 |
| 31.4:2 | Speed Indication | HCDSPEED value: [001]=10Mbps Half-duplex [101]=10Mbps Full-duplex [010]=100Base-TX Half-duplex [110]=100Base-TX Full-duplex | RO | 000 |
| 31.1 | Reserved | Write as 0; ignore on Read | RW | 0 |
| 31.0 | Scramble Disable | 0 = enable data scrambling 1 = disable data scrambling, | RW | 0 |

5.3 Management Interrupt

The Management interface supports an interrupt capability that is not a part of the IEEE 802.3 specification. It generates an active low interrupt signal on the nINT output whenever certain events are detected. Reading the Interrupt Source register (Register 29) shows the source of the interrupt, and clears the interrupt output signal. The Interrupt Mask register (Register 30) enables for each source to set (LOW) the nINT, by asserting the corresponding mask bit. The Mask bit does not mask the source bit in register 29. At reset, all bits are masked (negated). The nINT is an asynchronous output.

| Interrupt Source | Source/Mask Reg Bit # |
|------------------------------------|-----------------------|
| ENERGYON activated | 7 |
| Auto-Negotiate Complete | 6 |
| Remote Fault Detected | 5 |
| Link Status negated (not asserted) | 4 |
| Auto-Negotiation LP Acknowledge | 3 |
| Parallel Detection Fault | 2 |
| Auto-Negotiation Page Received | 1 |

5.4 Miscellaneous Functions

5.4.1 CARRIER SENSE

The carrier sense is output on CRS. CRS is a signal defined by the MII specification in the IEEE 802.3u standard. The PHY asserts CRS based only on receive activity whenever the PHY is either in repeater mode or full-duplex mode. Otherwise the PHY asserts CRS based on either transmit or receive activity.

The carrier sense logic uses the encoded, unscrambled data to determine carrier activity status. It activates carrier sense with the detection of 2 non-contiguous zeros within any 10 bit span. Carrier sense terminates if a span of 10 consecutive ones is detected before a /J/K/ Start-of Stream Delimiter pair. If an SSD pair is detected, carrier sense is asserted until either /T/R/ End-of-Stream Delimiter pair or a pair of IDLE symbols is detected. Carrier is negated after the /T/ symbol or the first IDLE. If /T/ is not followed by /R/, then carrier is maintained. Carrier is treated similarly for IDLE followed by some non-IDLE symbol.

5.4.2 COLLISION DETECT

A collision is the occurrence of simultaneous transmit and receive operations. The COL output is asserted to indicate that a collision has been detected. COL remains active for the duration of the collision. COL is changed asynchronously to both RX_CLK and TX_CLK. The COL output becomes inactive during full duplex mode.

COL may be tested by setting register 0, bit 7 high. This enables the collision test. COL will be asserted within 512 bit times of TX_EN rising and will be de-asserted within 4 bit times of TX_EN falling.

In 10M mode, COL pulses for approximately 10 bit times (1us), 2us after each transmitted packet (de-assertion of TX_EN). This is the Signal Quality Error (SQE) signal and indicates that the transmission was successful. The user can disable this pulse by setting bit 11 in register 27.

5.4.3 ISOLATE MODE

The PHY data paths may be electrically isolated from the MII by setting register 0, bit 10 to a logic one. In isolation mode, the PHY does not respond to the TXD, TX_EN and TX_ER inputs. The PHY still responds to management transactions.

Isolation provides a means for multiple PHYs to be connected to the same MII without contention occurring. The PHY is not isolated on power-up (bit 0:10 = 0).

5.4.4 LINK INTEGRITY TEST

The LAN83C185 performs the link integrity test as outlined in the IEEE 802.3u (Clause 24-15) Link Monitor state diagram. The link status is multiplexed with the 10Mbps link status to form the reportable link status bit in Serial Management Register 1, and is driven to the LINKON LED.

The DSP indicates a valid MLT-3 waveform present on the RXP and RXN signals as defined by the ANSI X3.263 TP-PMD standard, to the Link Monitor state-machine, using internal signal called DATA_VALID. When DATA_VALID is asserted the control logic moves into a Link-Ready state, and waits for an enable from the Auto Negotiation block. When received, the Link-Up state is entered, and the Transmit and Receive logic blocks become active. Should Auto Negotiation be disabled, the link integrity logic moves immediately to the Link-Up state, when the DATA_VALID is asserted.

Note that to allow the line to stabilize, the link integrity logic will wait a minimum of 330 μ sec from the time DATA_VALID is asserted until the Link-Ready state is entered. Should the DATA_VALID input be negated at any time, this logic will immediately negate the Link signal and enter the Link-Down state.

When the 10/100 digital block is in 10Base-T mode, the link status is from the 10Base-T receiver logic.

5.4.5 POWER-DOWN MODES

There are 2 power-down modes for the Phy:

5.4.5.1 General Power-Down

This power-down is controlled by register 0, bit 11. In this mode the entire PHY, except the management interface, is powered-down and stays in that condition as long as bit 0.11 is HIGH. When bit 0.11 is cleared, the PHY powers up and is automatically reset.

5.4.5.2 Energy Detect Power-Down

This power-down mode is activated by setting bit 17.13 to 1. In this mode when no energy is present on the line the PHY is powered down, except for the management interface, the SQUELCH circuit and the ENERGYON logic. The ENERGYON logic is used to detect the presence of valid energy from 100Base-TX, 10Base-T, or Auto-negotiation signals

LAN83C185

In this mode, when the ENERGYON signal is low, the PHY is powered-down, and nothing is transmitted. When energy is received - link pulses or packets - the ENERGYON signal goes high, and the PHY powers-up. It automatically resets itself into the state it had prior to power-down, and asserts the nINT interrupt if the ENERGYON interrupt is enabled. The first and possibly the second packet to activate ENERGYON may be lost.

When 17.13 is low, energy detect power-down is disabled.

5.4.6 RESET

The PHY has 3 reset sources:

Hardware reset (HWRST): connected to the nRST input, and to the internal POR signal.

If the nRST input is driven by an external source, it should be held LOW for at least 100 us to ensure that the Phy is properly reset.

The Phy has an internal Power-On-Reset (POR) signal which is asserted for 21ms following a VDD (+3.3V) and VDDCORE (+1.8V) power-up. This internal POR can be bypassed only in certain production test modes. This internal POR is internally "OR"-ed with the nRST input.

During a Hardware reset, either external or POR, an external clock **must** be supplied to the CLKIN signal.

Software (SW) reset: Activated by writing register 0, bit 15 high. This signal is self-clearing. After the register-write, internal logic extends the reset by 256µs to allow PLL-stabilization before releasing the logic from reset.

The IEEE 802.3u standard, clause 22 (22.2.4.1.1) states that the reset process should be completed within 0.5s from the setting of this bit.

Power-Down reset: Automatically activated when the PHY comes out of power-down mode. The internal power-down reset is extended by 256µs after exiting the power-down mode to allow the PLLs to stabilize before the logic is released from reset.

These 3 reset sources are combined together in the digital block to create the internal "general reset", SYSRST, which is an asynchronous reset and is active HIGH. This SYSRST directly drives the PCS, DSP and MII blocks. It is also input to the Central Bias block in order to generate a short reset for the PLLs.

The SMI mechanism and registers are reset only by the Hardware and Software resets. During Power-Down, the SMI registers are not reset. Note that some SMI register bits are not cleared by Software reset – these are marked "NASR" in the register tables.

For the first 16us after coming out of reset, the MII will run at 2.5 MHz. After that it will switch to 25 MHz if auto-negotiation is enabled.

5.4.7 LED DESCRIPTION

The PHY provides four LED signals. These provide a convenient means to determine the mode of operation of the Phy. All LED signals are either active high or active low.

Note: The four LED signals can be either active-high or active-low. Polarity depends upon the Phy address latched in on reset. The LAN83C185 senses each Phy address bit and changes the polarity of the LED signal accordingly. If the address bit is set as level "1", the LED polarity will be set to an active-low. If the address bit is set as level "0", the LED polarity will be set to an active-high.

FIGURE 5-1: PHY ADDRESS STRAPPING ON LEDS

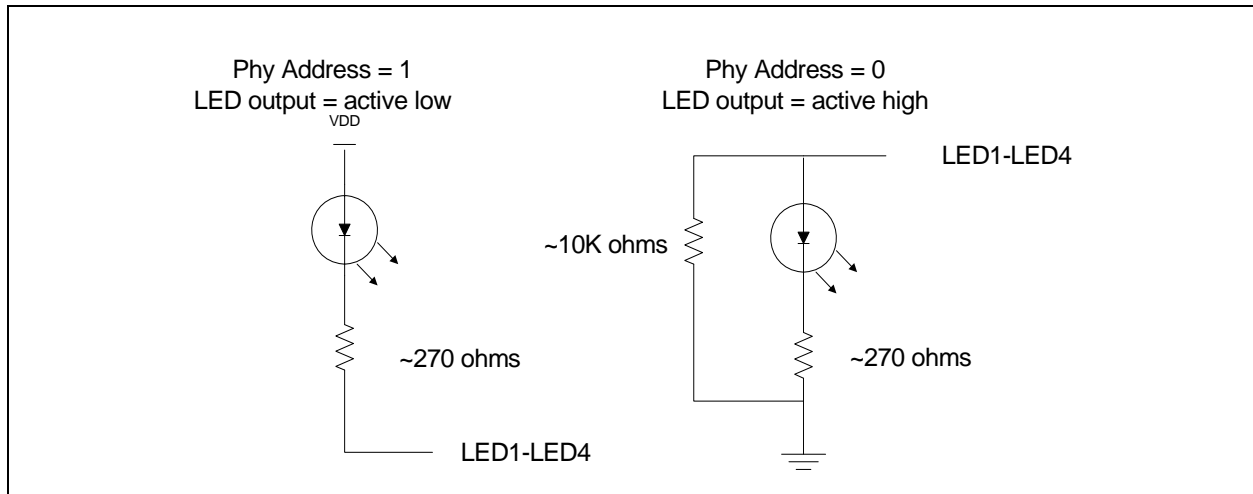

The ACTIVITY LED output is driven active when CRS is active (high). When CRS becomes inactive, the Activity LED output is extended by 128ms.

The LINKON LED output is driven active whenever the PHY detects a valid link. The use of the 10Mbps or 100Mbps link test status is determined by the condition of the internally determined speed selection.

The SPEED100 LED output is driven active when the operating speed is 100Mbit/s or during Auto-negotiation. This LED will go inactive when the operating speed is 10Mbit/s or during line isolation (register 31 bit 5).

The Full-Duplex LED output is driven active low when the link is operating in Full-Duplex mode.

5.4.8 LOOPBACK OPERATION

The 10/100 digital has two independent loop-back modes: Internal loopback and far loopback.

5.4.8.1 Internal Loopback

The internal loopback mode is enabled by setting bit register 0 bit 14 to logic one. In this mode, the scrambled transmit data (output of the scrambler) is looped into the receive logic (input of the descrambler). The COL signal will be inactive in this mode, unless collision test (bit 0.7) is active.

In this mode, during transmission (TX_EN is HIGH), nothing is transmitted to the line and the transmitters are powered down.

5.4.9 CONFIGURATION SIGNALS

The PHY has 11 configuration signals whose inputs should be driven continuously, either by external logic or external pull-up/pull-down resistors.

5.4.9.1 Physical Address Bus - PHYAD[4:0]

The PHYAD[4:0] signals are driven high or low to give each PHY a unique address. This address is latched into an internal register at end of hardware reset. In a multi-PHY application (such as a repeater), the controller is able to manage each PHY via the unique address. Each PHY checks each management data frame for a matching address in the relevant bits. When a match is recognized, the PHY responds to that particular frame. The PHY address is also used to seed the scrambler. In a multi-PHY application, this ensures that the scramblers are out of synchronization and disperses the electromagnetic radiation across the frequency spectrum.

LAN83C185

5.4.9.2 Mode Bus – MODE[2:0]

The MODE[2:0] bus controls the configuration of the 10/100 digital block.

TABLE 5-53: MODE[2:0] BUS

| Mode [2:0] | Mode Definitions | Default Register Bit Values | |
|------------|--|-----------------------------|------------|
| | | Register 0 | Register 4 |
| | | [13,12,10,8] | [8,7,6,5] |
| 000 | 10Base-T Half Duplex. Auto-negotiation disabled. | 0000 | N/A |
| 001 | 10Base-T Full Duplex. Auto-negotiation disabled. | 0001 | N/A |
| 010 | 100Base-TX Half Duplex. Auto-negotiation disabled. CRS is active during Transmit & Receive. | 1000 | N/A |
| 011 | 100Base-TX Full Duplex. Auto-negotiation disabled. CRS is active during Receive. | 1001 | N/A |
| 100 | 100Base-TX Half Duplex is advertised. Auto-negotiation enabled. CRS is active during Transmit & Receive. | 1100 | 0100 |
| 101 | Repeater mode. Auto-negotiation enabled. 100Base-TX Half Duplex is advertised. CRS is active during Receive. | 1100 | 0100 |
| 110 | Power Down mode. In this mode the PHY wake-up in Power-Down mode. | N/A | N/A |
| 111 | All capable. Auto-negotiation enabled. | X10X | 1111 |

5.5 Analog

The analog blocks of the chip are described in this section.

5.5.1 ADC

The ADC is a 6 bit 125 MHz sample rate Analog to Digital Converter designed to serve as the analog front end of a digital 100Base-Tx receiver.

5.5.1.1 Functional Description

The ADC has a full flash architecture for maximum speed and minimum latency. An internally generated 125MHz clock is used to time the sampling and processing.

The ADC has a variable gain, which is controlled by the DSP block. This allows accurate A/D conversion over the entire range of input signal amplitudes, which is particularly important for lower amplitude signals (longer cables).

5.5.1.1.1 Input Common Mode

The differential input is applied to the RXP/N signals. For proper operation of the ADC the input common mode should match the internal differential reference common mode. To achieve this, the ADC generates the appropriate voltage and drives it via the VCOM signal.

5.5.1.2 General Characteristics

| Item | Spec | Units | Remark |
|--------------------------|---------------------------------|-------|-----------------|
| Full Scale Input voltage | 3.0 Differential (peak-to-peak) | V | |
| Input Common Mode | 1.6-2.0 | V | Gain dependent. |

5.5.2 100M PLL

Three main functions are included in the 100M PLL: a clock multiplier to generate a 125MHz clock, a phase interpolator to synchronize the receive clock to the receive data, and a transmit wave-shaping delay reference.

5.5.2.1 Functional Description

The clock multiplier generates a multiple phase 125MHz from a 25MHz reference frequency.

The phase interpolator uses a multiplexer to select the phase used as the receive clock, RX_CLK. The multiplexer is controlled by signals generated in the DSP Timing unit. The Timing unit estimates the frequency drift of the received data clock and, by incrementing, decrementing or maintaining the selected phase, it generates a clock that is synchronized to the received data stream.

The 100M PLL also generates a fixed phase 125MHz clock, slaved to the VCO, that is used by the digital filter for accurate wave-shaping of the transmit output. It is also used as the transmitter clock of the PHY, TX_CLK. (This clock must be jitter-free thus cannot be the receive clock).

5.5.3 MT_100

This block generates the differential outputs driven onto TXP/TXN in 100Base-TX mode.

5.5.3.1 Functional Description

This block is a wave-shaped 100BASE-TX transmitter, with high impedance current outputs. The three level differential output (MLT-3) is shaped by differential current switches whose outputs are connected together. The low pass filtering (wave-shaping) of the current output is done by progressive switching of small current sources. The timing reference for the wave-shaping is the 125MHz fixed clock from the 100M PLL. The transmitter is designed to operate with a 1:1 transformer.

5.5.4 10M SQUELCH

The squelch circuit consists of squelch comparators and data comparators, which operate according to the 802.3 standard in Section 14.3.1.3.2.

5.5.5 10BT FILTER

The 10BASE-T Low Pass Filter is the front end of 10BASE-T signal path. It is designed to reject the high frequency noise from entering the squelch and data recovery blocks.

5.5.6 10M PLL - DATA RECOVERY CLOCK

The data recovery Phase Locked Loop (PLL) is used for data recovery for the 10BASE-T mode of operation. The data recovery PLL is used to synchronize the phase of the 10BASE-T data and the 20MHz VCO.

5.5.6.1 Functional Description

The Data recovery PLL has two modes of operation: Frequency Mode and Data Mode.

In frequency mode, the VCO locks to the external reference clock.

In Data mode, the VCO locks to the incoming data. When the PLL switches to Data mode, the VCO is held. It is released on an incoming data edge. This provides a minimum amount of phase error when the PLL switches from Frequency Mode to Data Mode.

5.5.7 PLL 10M - TRANSMIT CLOCK

The transmit Phase Locked Loop (PLL) is used to generate a precise delay for the 10BASE-T transmitter. It also provides a 20MHz clock for the transmit digital block.

5.5.7.1 Functional Description

This PLL is used to provide a Transmit clock to the digital and create a delay for the 10BASE-T transmitter.

The Transmit PLL operates continuously in a frequency mode of operation where it is locked to the input clock.

LAN83C185

5.5.8 XMT_10

This block generates the differential outputs driven onto TXP/TXN in 10Base-T mode.

5.5.8.1 Functional Description

This block is a wave-shaped 10BASE-T transmitter, with high impedance current outputs. The low pass filtering (wave-shaping) of the current output is done by progressive switching of small current sources. The timing reference for the wave-shaping is the 10BASE-T transmit PLL. The transmitter is designed to operate with a 1:1 turn-ratio transformer.

5.5.9 CENTRAL BIAS

The Central Bias block generates a power-up reset signal, a PLL reset signal and the bias currents/voltages needed by other on-chip blocks.

5.5.9.1 Functional Description

This block has three main functions: Reference bias current and voltage generator, power-up reset, and PLL reset.

The bias generator generates accurate currents and voltages using an on-chip bandgap circuit and an external 12.4K 1% resistor.

The power-up reset circuit generates a signal that stays high for 10 ms. This duration is controlled through the use of counters and a 25MHz internal clock. An analog power-up circuit is used to set the initial conditions and ensure proper startup of the circuit.

The PLL reset signal is generated after the occurrence of an active nRST. The internal reset signal is asserted for the duration of four 25MHz clocks (160ns). It is then released. Releasing the PLL reset early ensures that the PLL locks to the reference clock before the system reset (nRST) is released.

5.6 DSP Block

5.6.1 GENERAL DESCRIPTION

The “DSP Block” includes the following modules:

DSP Core (Equalizer, Timing and BLW correction), Testability / Configuration module (Testability / Configuration control), Testability / Configuration Registers (not including any SMI registers) and the Multiplexers (for the testability / configuration signals).

The details of the DSP core are described in the DSP architecture specification. The Testability / Configuration features give access to the status and control of most of the internal registers in the DSP. The status and control mechanisms are described in the architecture specification.

5.6.2 ADC GRAY CODE CONVERTING

The LAN83C185 ADC generates a 6 bit “modified” Gray code. Normal Gray code outputs number in the range of 0 to $2^n - 1$. The 6-bit code generates numbers from 0 to 63 (decimal).

The MLT3 analog input has a voltage range of $-1V$ to $+1V$. It is necessary to translate this to -32 to $+31$ on the output of the ADC. Thus the Gray Code is modified by offsetting it by -32 . This is translated to 2's complement before being presented to the DSP.

6.0 ELECTRICAL CHARACTERISTICS

The timing diagrams and limits in this section define the requirements placed on the external signals of the Phy.

6.1 Serial Management Interface (SMI) Timing

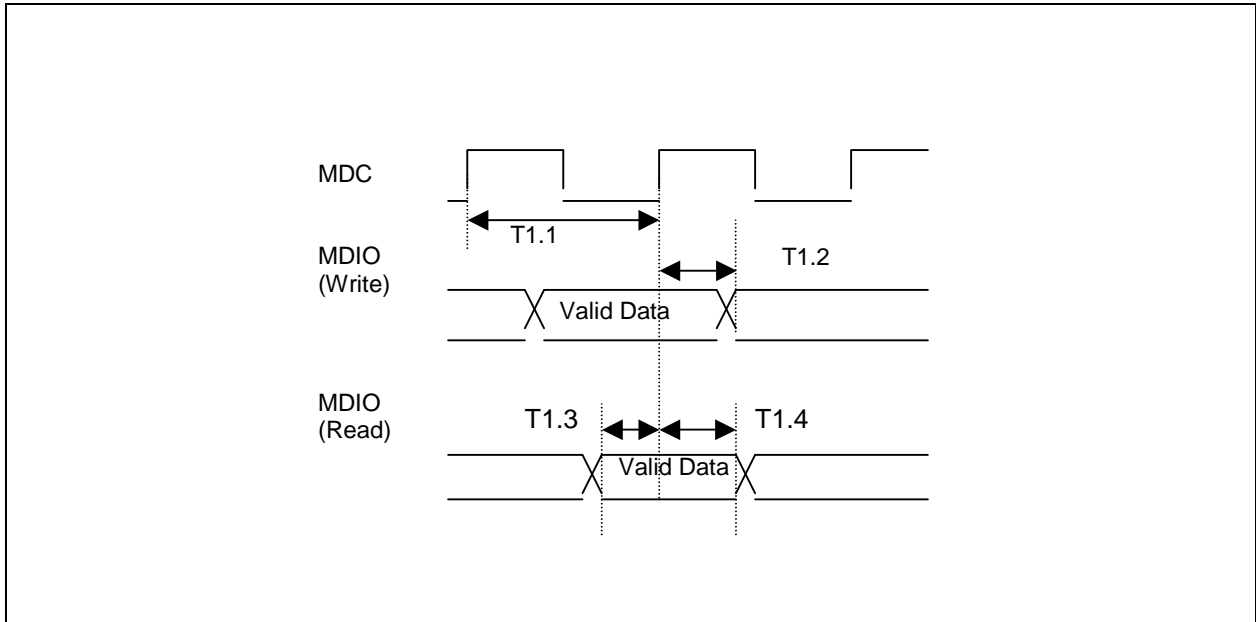

| Parameter | Description | Min | Typ | Max | Units | Notes |
|-----------|---------------------------|-----|-----|-----|-------|-------|
| T1.1 | MDC frequency | | | 2.5 | MHz | |
| T1.2 | MDC to MDIO (Write) delay | 0 | | 300 | ns | |
| T1.3 | MDIO (Read) to MDC setup | 10 | | | ns | |
| T1.4 | MDIO (Read) to MDC hold | 10 | | | ns | |

LAN83C185

6.2 100Base-TX Timings

6.2.1 100M MII RECEIVE TIMING

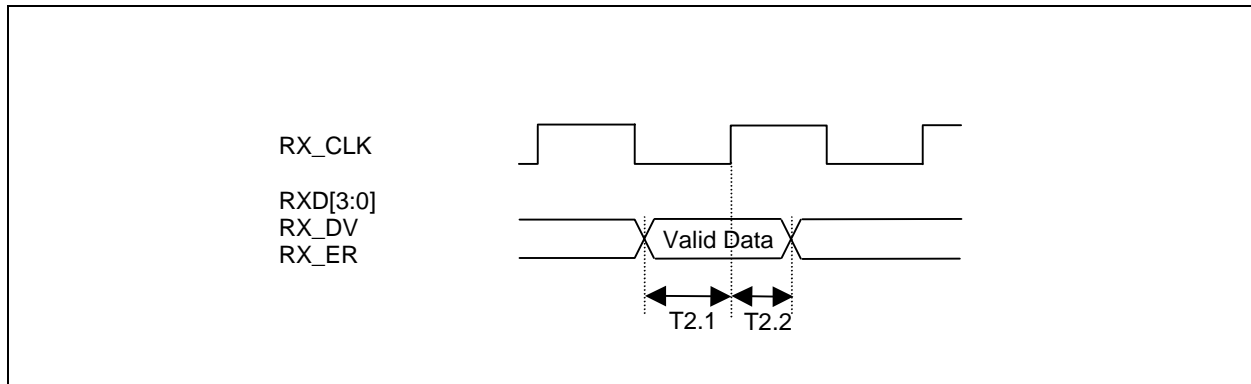

| Parameter | Description | Min | Typ | Max | Units | Notes |
|-----------|---|-----|-----|-----|-------|-------|
| T2.1 | Receive signals setup to RX_CLK rising | 10 | | | ns | |
| T2.2 | Receive signals hold from RX_CLK rising | 10 | | | ns | |
| | RX_CLK frequency | | 25 | | MHz | |
| | RX_CLK Duty-Cycle | | 40 | | % | |

6.2.2 100M MII TRANSMIT TIMING

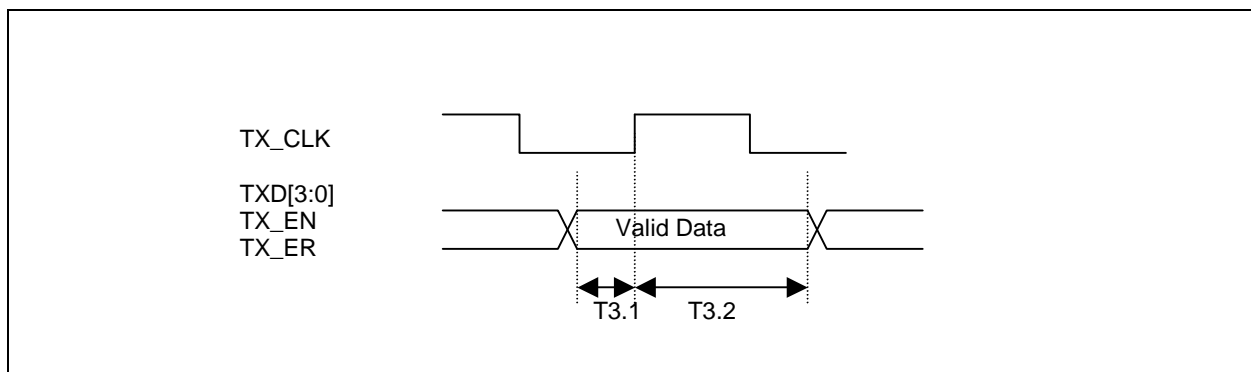

| Parameter | Description | Min | Typ | Max | Units | Notes |
|-----------|---|-----|-----|-----|-------|-------|
| T3.1 | Transmit signals setup to TX_CLK rising | 12 | | | ns | |
| T3.2 | Transmit signals hold after TX_CLK rising | 0 | | | ns | |
| | TX_CLK frequency | | 25 | | MHz | |
| | TX_CLK Duty-Cycle | | 40 | | % | |

6.3 10Base-T Timings

6.3.1 10M MII RECEIVE TIMING

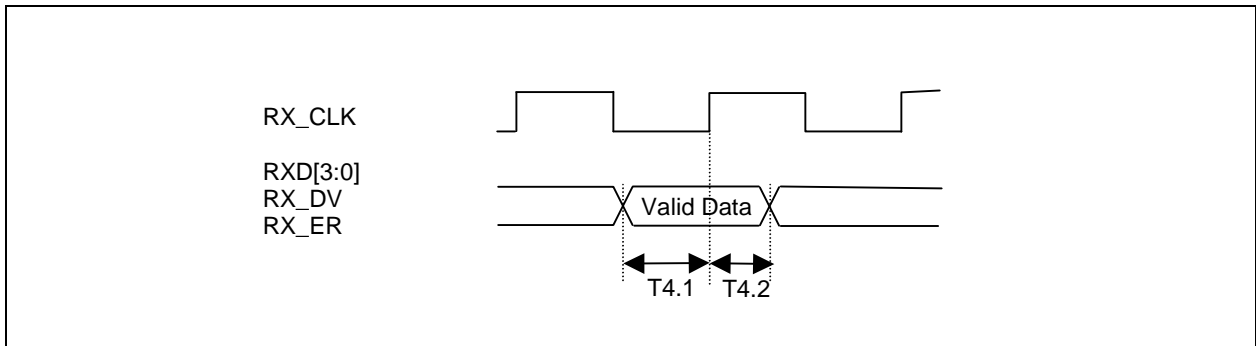

| Parameter | Description | Min | Typ | Max | Units | Notes |
|-----------|---|-----|-----|-----|-------|-------|
| T4.1 | Receive signals setup to RX_CLK rising | 10 | | | ns | |
| T4.2 | Receive signals hold from RX_CLK rising | 10 | | | ns | |
| | RX_CLK frequency | | 25 | | MHz | |
| | RX_CLK Duty-Cycle | | 40 | | % | |
| | Receive signals setup to RX_CLK rising | 10 | | | ns | |

6.3.2 10M MII TRANSMIT TIMING

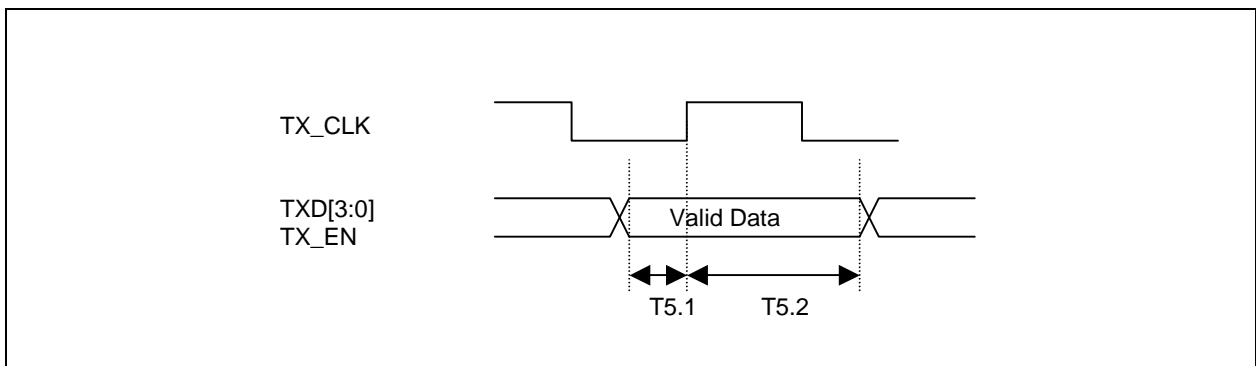

| Parameter | Description | Min | Typ | Max | Units | Notes |
|-----------|---|-----|-----|-----|-------|-------|
| T5.1 | Transmit signals setup to TX_CLK rising | 12 | | | ns | |
| T5.2 | Transmit signals hold after TX_CLK rising | | | 0 | ns | |
| | TX_CLK frequency | | 2.5 | | MHz | |
| | TX_CLK Duty-Cycle | | 50 | | % | |

LAN83C185

6.4 Reset Timing

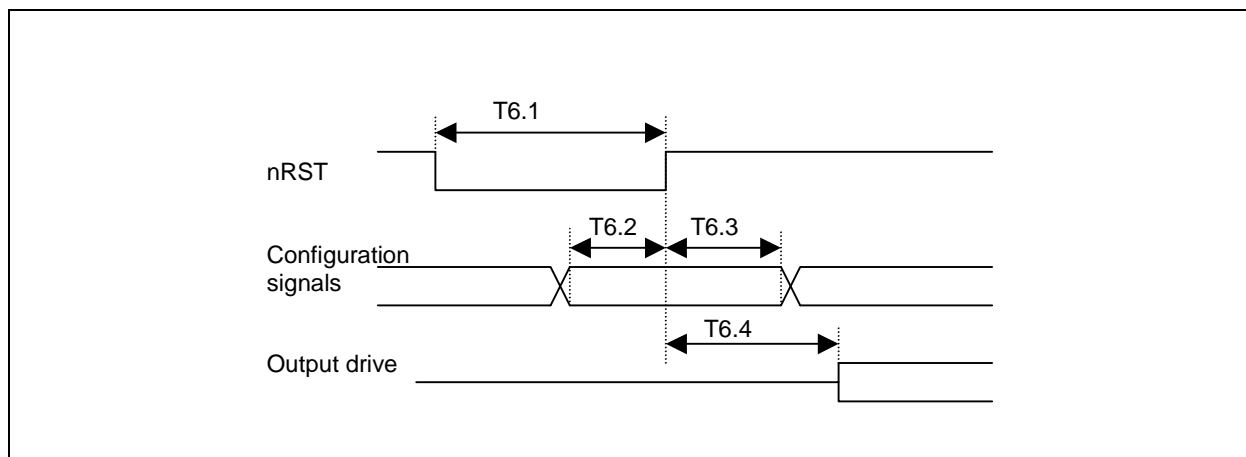

| Parameter | Description | Min | Typ | Max | Units | Notes |
|-----------|--|-----|-----|-----|-------|----------------------------------|
| T6.1 | Reset Pulse Width | 100 | | | us | |
| T6.2 | Configuration input setup to nRST rising | 200 | | | ns | |
| T6.3 | Configuration input hold after nRST rising | 400 | | | ns | |
| T6.4 | Output Drive after nRST rising | 20 | | 800 | ns | 20 clock cycles for 25 MHz clock |

6.5 DC Characteristics

6.5.1 OPERATING CONDITIONS

Supply Voltage +3.3V +/- 10%
 Operating Temperature 0°C to 70°C

6.5.2 POWER CONSUMPTION

6.5.2.1 Power Consumption Device Only

Power measurements taken under the following conditions:

Temperature: +25° C
 Device VDD: +3.30 V

TABLE 6-1: POWER CONSUMPTION DEVICE ONLY

| Mode | Total Power (mW) | Digital Power | | Analog Power | | Regulator Supply Current | |
|-----------------------------|------------------|---------------|--------------|--------------|--------------|--------------------------|--------------|
| | | Power (mW) | Current (mA) | Power (mW) | Current (mA) | Power (mW) | Current (mA) |
| 10BASE-T Operation | | | | | | | |
| 10BASE-T /w traffic | 96 | 33 | 10 | 59 | 18 | 4 | 1 |
| Idle | 83 | 20 | 6 | 59 | 18 | 4 | 1 |
| Energy Detect Power Down | 45 | 17 | 5 | 24 | 7 | 4 | 1 |
| AN General Power Down | 45 | 17 | 5 | 24 | 7 | 4 | 1 |
| Non-AN Gen Power Down | 22 | 17 | 5 | 0.66 | 0.200 | 4 | 1 |
| 100BASE-TX Operation | | | | | | | |
| 100BASE-TX /w traffic | 261 | 66 | 20 | 132 | 40 | 63 | 19 |
| Idle | 245 | 50 | 15 | 132 | 40 | 63 | 19 |
| Energy Detect Power Down | 45 | 17 | 5 | 24 | 7 | 4 | 1 |
| AN General Power Down | 45 | 17 | 5 | 24 | 7 | 4 | 1 |
| Non-AN Gen Power Down | 22 | 17 | 5 | 0.66 | 0.200 | 4 | 1 |

Note 1: Each LED indicator in use adds approximately 4 mA to the Digital power supply.

- 2:** Digital Power pins on LAN83C185 are: VDD pins 8, 18, 43.
- 3:** Analog Power pins on LAN83C185 are: AVDD pins 53, 57, 61, 63.
- 4:** Regulator Supply pins on LAN83C185 are: VREG pin 13.
- 5:** Traffic Utilization = 100%
- 6:** Mode of Operation in both cases is full duplex.

LAN83C185

6.5.2.2 Power Consumption Device and System Components

Power measurements taken under the following conditions:

Temperature: +25° C

Device VDD: +3.30 V

TABLE 6-2: POWER CONSUMPTION DEVICE AND SYSTEM COMPONENTS

| Mode | Total Power (mW) | Digital Power | | Analog Power | | Regulator Supply Current | |
|-----------------------------|------------------|---------------|--------------|--------------|--------------|--------------------------|--------------|
| | | Power (mW) | Current (mA) | Power (mW) | Current (mA) | Power (mW) | Current (mA) |
| 10BASE-T Operation | | | | | | | |
| 10BASE-T /w traffic | 476 | 33 | 10 | 439 | 133 | 4 | 1 |
| Idle | 463 | 20 | 6 | 439 | 133 | 4 | 1 |
| Energy Detect Power Down | 45 | 17 | 5 | 24 | 7 | 4 | 1 |
| AN General Power Down | 45 | 17 | 5 | 24 | 7 | 4 | 1 |
| Non-AN Gen Power Down | 22 | 17 | 5 | .66 | .200 | 4 | 1 |
| 100BASE-TX Operation | | | | | | | |
| 100BASE-TX /w traffic | 400 | 66 | 20 | 271 | 82 | 63 | 19 |
| Idle | 384 | 50 | 15 | 271 | 82 | 63 | 19 |
| Energy Detect Power Down | 45 | 17 | 5 | 24 | 7 | 4 | 1 |
| AN General Power Down | 45 | 17 | 5 | 24 | 7 | 4 | 1 |
| Non-AN Gen Power Down | 22 | 17 | 5 | .66 | .200 | 4 | 1 |

- Note 1:** Each LED indicator in use adds approximately 4 mA to the Digital power supply.
- 2:** Digital Power pins on LAN83C185 are: VDD pins 8, 18, 43.
- 3:** Analog Power pins on LAN83C185 are: AVDD pins 53, 57, 61, 63.
- 4:** Regulator Supply pins on LAN83C185 are: VREG pin 13.
- 5:** Traffic Utilization = 100%
- 6:** Mode of Operation in both cases is full duplex.

6.5.3 DC CHARACTERISTICS - INPUT AND OUTPUT BUFFERS

TABLE 6-3: MII BUS INTERFACE SIGNALS

| Pin No. | Name | V _{IH} | V _{IL} | I _{OH} | I _{OL} | V _{OL} | V _{OH} |
|---------|------------|-----------------|-----------------|-----------------|-----------------|-----------------|-----------------|
| 41 | TXD0 | +2.0 V | +0.8 V | | | | |
| 42 | TXD1 | +2.0 V | +0.8 V | | | | |
| 44 | TXD2 | +2.0 V | +0.8 V | | | | |
| 45 | TXD3 | +2.0 V | +0.8 V | | | | |
| 37 | TX_ER/TXD4 | +2.0 V | +0.8 V | | | | |
| 39 | TX_EN | +2.0 V | +0.8 V | | | | |
| 38 | TX_CLK | | | -8 mA | +8 mA | +0.4 V | VDD – +0.4 V |
| 32 | RXD0 | | | -8 mA | +8 mA | +0.4 V | VDD – +0.4 V |
| 31 | RXD1 | | | -8 mA | +8 mA | +0.4 V | VDD – +0.4 V |
| 30 | RXD2 | | | -8 mA | +8 mA | +0.4 V | VDD – +0.4 V |
| 29 | RXD3 | | | -8 mA | +8 mA | +0.4 V | VDD – +0.4 V |
| 35 | RX_ER/RXD4 | | | -8 mA | +8 mA | +0.4 V | VDD – +0.4 V |
| 33 | RX_DV | | | -8 mA | +8 mA | +0.4 V | VDD – +0.4 V |
| 34 | RX_CLK | | | -8 mA | +8 mA | +0.4 V | VDD – +0.4 V |
| 48 | CRS | | | -8 mA | +8 mA | +0.4 V | VDD – +0.4 V |
| 47 | COL | | | -8 mA | +8 mA | +0.4 V | VDD – +0.4 V |
| 27 | MDC | +2.0 V | +0.8 V | | | | |
| 26 | MDIO | | | -8 mA | +8 mA | +0.4 V | VDD – +0.4 V |

TABLE 6-4: LAN INTERFACE SIGNALS

| Pin No. | Name | V _{IH} | V _{IL} | I _{OH} | I _{OL} | V _{OL} | V _{OH} |
|---------|------|--|-----------------|-----------------|-----------------|-----------------|-----------------|
| 51 | TXP | See Table 6-10, "100Base-TX Transceiver Characteristics," on page 49 and Table 6-11, "10BASE-T Transceiver Characteristics," on page 49. | | | | | |
| 50 | TXN | | | | | | |
| 55 | RXP | | | | | | |
| 54 | RXN | | | | | | |

TABLE 6-5: LED SIGNALS

| Pin No. | Name | V _{IH} | V _{IL} | I _{OH} | I _{OL} | V _{OL} | V _{OH} |
|---------|----------|-----------------|-----------------|-----------------|-----------------|-----------------|-----------------|
| 16 | SPEED100 | +2.0 V | +0.8 V | -12 mA | +24 mA | +0.4 V | VDD – +0.4 V |
| 17 | LINKON | +2.0 V | +0.8 V | -12 mA | +24 mA | +0.4 V | VDD – +0.4 V |
| 19 | ACTIVITY | +2.0 V | +0.8 V | -12 mA | +24 mA | +0.4 V | VDD – +0.4 V |
| 20 | FDUPLEX | +2.0 V | +0.8 V | -12 mA | +24 mA | +0.4 V | VDD – +0.4 V |

TABLE 6-6: CONFIGURATION INPUTS

| Pin No. | Name | V _{IH} | V _{IL} | I _{OH} | I _{OL} | V _{OL} | V _{OH} |
|---------|--------|-----------------|-----------------|-----------------|-----------------|-----------------|-----------------|
| 16 | PHYAD0 | +2.0 V | +0.8 V | -12 mA | +24 mA | +0.4 V | VDD – +0.4 V |
| 17 | PHYAD1 | +2.0 V | +0.8 V | -12 mA | +24 mA | +0.4 V | VDD – +0.4 V |
| 19 | PHYAD2 | +2.0 V | +0.8 V | -12 mA | +24 mA | +0.4 V | VDD – +0.4 V |
| 20 | PHYAD3 | +2.0 V | +0.8 V | -12 mA | +24 mA | +0.4 V | VDD – +0.4 V |
| 2 | PHYAD4 | | | -4 mA | +8 mA | +0.4 V | VDD – +0.4 V |
| 4 | MODE0 | +2.0 V | +0.8 V | | | | |

LAN83C185

TABLE 6-6: CONFIGURATION INPUTS (CONTINUED)

| Pin No. | Name | V _{IH} | V _{IL} | I _{OH} | I _{OL} | V _{OL} | V _{OH} |
|---------|----------|-----------------|-----------------|-----------------|-----------------|-----------------|-----------------|
| 5 | MODE1 | +2.0 V | +0.8 V | | | | |
| 6 | MODE2 | +2.0 V | +0.8 V | | | | |
| 9 | TEST0 | +2.0 V | +0.8 V | | | | |
| 10 | TEST1 | +2.0 V | +0.8 V | | | | |
| 11 | CLK_FREQ | +2.0 V | +0.8 V | | | | |
| 12 | REG_EN | | | | | | |
| 1 | MII | | | -4 mA | +8 mA | +0.4 V | VDD – +0.4 V |

TABLE 6-7: GENERAL SIGNALS

| Pin No. | Name | V _{IH} | V _{IL} | I _{OH} | I _{OL} | V _{OL} | V _{OH} |
|---------|-------------|-----------------|-----------------|-----------------|-----------------|-----------------|-----------------|
| 1 | GPO0 | | | -4 mA | +8 mA | +0.4 V | VDD – +0.4 V |
| 2 | GPO1 | | | -4 mA | +8 mA | +0.4 V | VDD – +0.4 V |
| 3 | GPO2 | | | -4 mA | +8 mA | +0.4 V | VDD – +0.4 V |
| 46 | nINT | | | -4 mA | +8 mA | +0.4 V | VDD – +0.4 V |
| 25 | nRST | | | | | | |
| 23 | CLKIN/XTAL1 | | | | | | |
| 22 | XTAL2 | | | | | | |
| 64 | NC1 | | | | | | |

TABLE 6-8: ANALOG REFERENCES

| Pin No. | Name | V _{IH} | V _{IL} | I _{OH} | I _{OL} | V _{OL} | V _{OH} |
|---------|--------|-----------------|-----------------|-----------------|-----------------|-----------------|-----------------|
| 59 | EXRES1 | | | | | | |
| 56 | NC2 | | | | | | |

TABLE 6-9: INTERNAL PULL-UP / PULL-DOWN CONFIGURATIONS

| Pin No. | Name | Pull-Up or Pull-Down | Type |
|---------|-------------|----------------------|------------|
| 1 | GPO0/MII | Pull-down | 30 μ A |
| 2 | GPO1/PHYAD4 | Pull-up | 30 μ A |
| 4 | MODE0 | Pull-up | 30 μ A |
| 5 | MODE1 | Pull-up | 30 μ A |
| 6 | MODE2 | Pull-up | 30 μ A |
| 9 | TEST0 | Pull-down | 30 μ A |
| 10 | TEST1 | Pull-down | 30 μ A |
| 16 | SPEED100 | Pull-up | 30 μ A |
| 17 | LINKON | Pull-up | 30 μ A |
| 19 | ACTIVITY | Pull-up | 30 μ A |
| 20 | FDUPLEX | Pull-up | 30 μ A |
| 46 | nINT | Pull-up | 30 μ A |

TABLE 6-10: 100BASE-TX TRANSCEIVER CHARACTERISTICS

| Parameter | Symbol | MIN | TYP | MAX | Units | Notes |
|---------------------------------------|-----------|------|-----|-------|-------|--------------------------|
| Peak Differential Output Voltage High | V_{PPH} | 950 | - | 1050 | mVpk | Note 6-1 |
| Peak Differential Output Voltage Low | V_{PPL} | -950 | - | -1050 | mVpk | Note 6-1 |
| Signal Amplitude Symmetry | V_{SS} | 98 | - | 102 | % | Note 6-1 |
| Signal Rise & Fall Time | T_{RF} | 3.0 | - | 5.0 | nS | Note 6-1 |
| Rise & Fall Time Symmetry | T_{RFS} | - | - | 0.5 | nS | Note 6-1 |
| Duty Cycle Distortion | D_{CD} | 35 | 50 | 65 | % | Note 6-2 |
| Overshoot & Undershoot | V_{OS} | - | - | 5 | % | |
| Jitter | | | | 1.4 | nS | Note 6-3 |

Note 6-1 Measured at the line side of the transformer, line replaced by 100Ω (+/- 1%) resistor.

Note 6-2 Offset from 16 nS pulse width at 50% of pulse peak

Note 6-3 Measured differentially.

TABLE 6-11: 10BASE-T TRANSCEIVER CHARACTERISTICS

| Parameter | Symbol | MIN | TYP | MAX | Units | Notes |
|--|-----------|-----|-----|-----|-------|--------------------------|
| Transmitter Peak Differential Output Voltage | V_{OUT} | 2.2 | 2.5 | 2.8 | V | Note 6-4 |
| Receiver Differential Squelch Threshold | V_{DS} | 300 | 420 | 585 | mV | |

Note 6-4 Min/max voltages ensured as measured with 100Ω resistive load.

LAN83C185

7.0 PACKAGE OUTLINE

FIGURE 7-1: 64-PIN TQFP PACKAGE OUTLINE, 10X10X1.4 BODY, 2MM FOOTPRINT

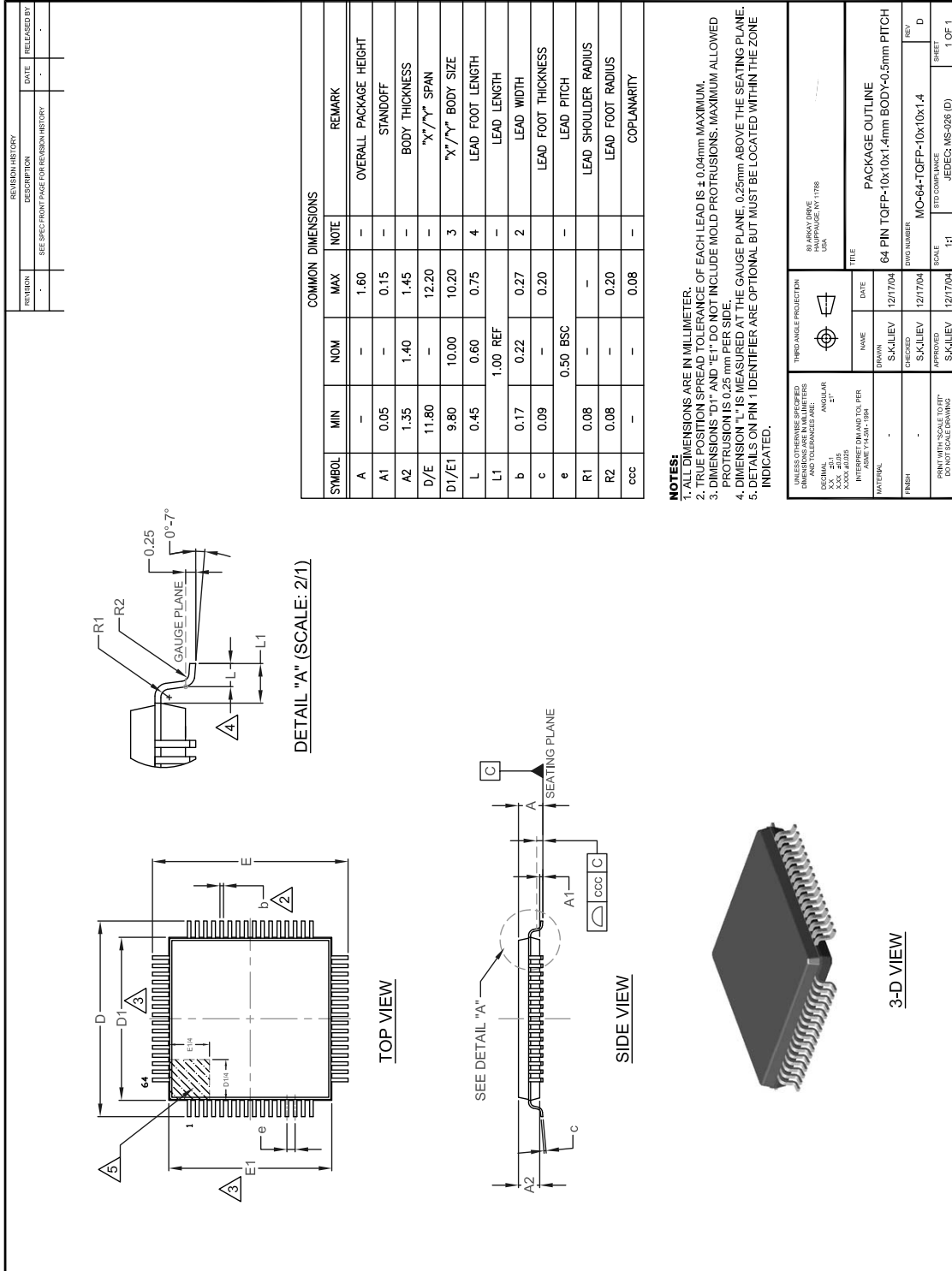

APPENDIX A: DATA SHEET REVISION HISTORY

TABLE A-1: REVISION HISTORY

| Revision | Section/Figure/Entry | Correction |
|------------------------|--|------------|
| DS00002808A (10-29-18) | Replaces previous SMSC version Rev. 0.8 (06-12-08) | |

LAN83C185

THE MICROCHIP WEB SITE

Microchip provides online support via our WWW site at www.microchip.com. This web site is used as a means to make files and information easily available to customers. Accessible by using your favorite Internet browser, the web site contains the following information:

- **Product Support** – Data sheets and errata, application notes and sample programs, design resources, user's guides and hardware support documents, latest software releases and archived software
- **General Technical Support** – Frequently Asked Questions (FAQ), technical support requests, online discussion groups, Microchip consultant program member listing
- **Business of Microchip** – Product selector and ordering guides, latest Microchip press releases, listing of seminars and events, listings of Microchip sales offices, distributors and factory representatives

CUSTOMER CHANGE NOTIFICATION SERVICE

Microchip's customer notification service helps keep customers current on Microchip products. Subscribers will receive e-mail notification whenever there are changes, updates, revisions or errata related to a specified product family or development tool of interest.

To register, access the Microchip web site at www.microchip.com. Under "Support", click on "Customer Change Notification" and follow the registration instructions.

CUSTOMER SUPPORT

Users of Microchip products can receive assistance through several channels:

- Distributor or Representative
- Local Sales Office
- Field Application Engineer (FAE)
- Technical Support

Customers should contact their distributor, representative or field application engineer (FAE) for support. Local sales offices are also available to help customers. A listing of sales offices and locations is included in the back of this document.

Technical support is available through the web site at: <http://www.microchip.com/support>

PRODUCT IDENTIFICATION SYSTEM

To order or obtain information, e.g., on pricing or delivery, refer to the factory or the listed sales office.

| <u>PART NO.</u> | - | <u>XX</u> | - | <u>[X]</u> |
|-----------------------|-------|-----------|------------------------------|----------------------|
| Device | | Package | | Tape and Reel Option |
| Device: | | LAN83C185 | | |
| Package: | JT | = | 64-Pin TQFP | |
| Tape and Reel Option: | Blank | = | Tray packaging | |
| | TR | = | Tape and Reel ⁽¹⁾ | |

Example:

- LAN83C185-JT = 64-Pin TQFP RoHS Compliant Package, Tray

Note 1: Tape and Reel identifier only appears in the catalog part number description. This identifier is used for ordering purposes and is not printed on the device package. Check with your Microchip Sales Office for package availability with the Tape and Reel option.

LAN83C185

Note the following details of the code protection feature on Microchip devices:

- Microchip products meet the specification contained in their particular Microchip Data Sheet.
- Microchip believes that its family of products is one of the most secure families of its kind on the market today, when used in the intended manner and under normal conditions.
- There are dishonest and possibly illegal methods used to breach the code protection feature. All of these methods, to our knowledge, require using the Microchip products in a manner outside the operating specifications contained in Microchip's Data Sheets. Most likely, the person doing so is engaged in theft of intellectual property.
- Microchip is willing to work with the customer who is concerned about the integrity of their code.
- Neither Microchip nor any other semiconductor manufacturer can guarantee the security of their code. Code protection does not mean that we are guaranteeing the product as “unbreakable.”

Code protection is constantly evolving. We at Microchip are committed to continuously improving the code protection features of our products. Attempts to break Microchip's code protection feature may be a violation of the Digital Millennium Copyright Act. If such acts allow unauthorized access to your software or other copyrighted work, you may have a right to sue for relief under that Act.

Information contained in this publication regarding device applications and the like is provided only for your convenience and may be superseded by updates. It is your responsibility to ensure that your application meets with your specifications. MICROCHIP MAKES NO REPRESENTATIONS OR WARRANTIES OF ANY KIND WHETHER EXPRESS OR IMPLIED, WRITTEN OR ORAL, STATUTORY OR OTHERWISE, RELATED TO THE INFORMATION, INCLUDING BUT NOT LIMITED TO ITS CONDITION, QUALITY, PERFORMANCE, MERCHANTABILITY OR FITNESS FOR PURPOSE. Microchip disclaims all liability arising from this information and its use. Use of Microchip devices in life support and/or safety applications is entirely at the buyer's risk, and the buyer agrees to defend, indemnify and hold harmless Microchip from any and all damages, claims, suits, or expenses resulting from such use. No licenses are conveyed, implicitly or otherwise, under any Microchip intellectual property rights unless otherwise stated.

Trademarks

The Microchip name and logo, the Microchip logo, AnyRate, AVR, AVR logo, AVR Freaks, BitCloud, chipKIT, chipKIT logo, CryptoMemory, CryptoRF, dsPIC, FlashFlex, flexPWR, Heldo, JukeBlox, KeeLoq, Klear, LANCheck, LINK MD, maXStylus, maXTouch, MediaLB, megaAVR, MOST, MOST logo, MPLAB, OptoLyzer, PIC, picoPower, PICSTART, PIC32 logo, Prochip Designer, QTouch, SAM-BA, SpyNIC, SST, SST Logo, SuperFlash, tinyAVR, UNI/O, and XMEGA are registered trademarks of Microchip Technology Incorporated in the U.S.A. and other countries.

ClockWorks, The Embedded Control Solutions Company, EtherSynch, Hyper Speed Control, HyperLight Load, IntellIMOS, mTouch, Precision Edge, and Quiet-Wire are registered trademarks of Microchip Technology Incorporated in the U.S.A.

Adjacent Key Suppression, AKS, Analog-for-the-Digital Age, Any Capacitor, AnyIn, AnyOut, BodyCom, CodeGuard, CryptoAuthentication, CryptoAutomotive, CryptoCompanion, CryptoController, dsPICDEM, dsPICDEM.net, Dynamic Average Matching, DAM, ECAN, EtherGREEN, In-Circuit Serial Programming, ICSP, INICnet, Inter-Chip Connectivity, JitterBlocker, KlearNet, KlearNet logo, memBrain, Mindi, MiWi, motorBench, MPASM, MPF, MPLAB Certified logo, MPLIB, MPLINK, MultiTRAK, NetDetach, Omniscient Code Generation, PICDEM, PICDEM.net, PICkit, PICtail, PowerSmart, PureSilicon, QMatrix, REAL ICE, Ripple Blocker, SAM-ICE, Serial Quad I/O, SMART-I.S., SQI, SuperSwitcher, SuperSwitcher II, Total Endurance, TSHARC, USBCheck, VariSense, ViewSpan, WiperLock, Wireless DNA, and ZENA are trademarks of Microchip Technology Incorporated in the U.S.A. and other countries.

SQTP is a service mark of Microchip Technology Incorporated in the U.S.A.

Silicon Storage Technology is a registered trademark of Microchip Technology Inc. in other countries.

GestIC is a registered trademark of Microchip Technology Germany II GmbH & Co. KG, a subsidiary of Microchip Technology Inc., in other countries.

All other trademarks mentioned herein are property of their respective companies.

© 2018, Microchip Technology Incorporated, All Rights Reserved.

ISBN: 9781522436034

QUALITY MANAGEMENT SYSTEM
CERTIFIED BY DNV
== ISO/TS 16949 ==

Microchip received ISO/TS-16949:2009 certification for its worldwide headquarters, design and wafer fabrication facilities in Chandler and Tempe, Arizona; Gresham, Oregon and design centers in California and India. The Company's quality system processes and procedures are for its PIC® MCUs and dsPIC® DSCs, KEELOQ® code hopping devices, Serial EEPROMs, microperipherals, nonvolatile memory and analog products. In addition, Microchip's quality system for the design and manufacture of development systems is ISO 9001:2000 certified.



Worldwide Sales and Service

AMERICAS

Corporate Office
2355 West Chandler Blvd.
Chandler, AZ 85224-6199
Tel: 480-792-7200
Fax: 480-792-7277
Technical Support:
[http://www.microchip.com/
support](http://www.microchip.com/support)
Web Address:
www.microchip.com

Atlanta
Duluth, GA
Tel: 678-957-9614
Fax: 678-957-1455

Austin, TX
Tel: 512-257-3370

Boston
Westborough, MA
Tel: 774-760-0087
Fax: 774-760-0088

Chicago
Itasca, IL
Tel: 630-285-0071
Fax: 630-285-0075

Dallas
Addison, TX
Tel: 972-818-7423
Fax: 972-818-2924

Detroit
Novi, MI
Tel: 248-848-4000

Houston, TX
Tel: 281-894-5983

Indianapolis
Noblesville, IN
Tel: 317-773-8323
Fax: 317-773-5453
Tel: 317-536-2380

Los Angeles
Mission Viejo, CA
Tel: 949-462-9523
Fax: 949-462-9608
Tel: 951-273-7800

Raleigh, NC
Tel: 919-844-7510

New York, NY
Tel: 631-435-6000

San Jose, CA
Tel: 408-735-9110
Tel: 408-436-4270

Canada - Toronto
Tel: 905-695-1980
Fax: 905-695-2078

ASIA/PACIFIC

Australia - Sydney
Tel: 61-2-9868-6733

China - Beijing
Tel: 86-10-8569-7000

China - Chengdu
Tel: 86-28-8665-5511

China - Chongqing
Tel: 86-23-8980-9588

China - Dongguan
Tel: 86-769-8702-9880

China - Guangzhou
Tel: 86-20-8755-8029

China - Hangzhou
Tel: 86-571-8792-8115

China - Hong Kong SAR
Tel: 852-2943-5100

China - Nanjing
Tel: 86-25-8473-2460

China - Qingdao
Tel: 86-532-8502-7355

China - Shanghai
Tel: 86-21-3326-8000

China - Shenyang
Tel: 86-24-2334-2829

China - Shenzhen
Tel: 86-755-8864-2200

China - Suzhou
Tel: 86-186-6233-1526

China - Wuhan
Tel: 86-27-5980-5300

China - Xian
Tel: 86-29-8833-7252

China - Xiamen
Tel: 86-592-2388138

China - Zhuhai
Tel: 86-756-3210040

ASIA/PACIFIC

India - Bangalore
Tel: 91-80-3090-4444

India - New Delhi
Tel: 91-11-4160-8631

India - Pune
Tel: 91-20-4121-0141

Japan - Osaka
Tel: 81-6-6152-7160

Japan - Tokyo
Tel: 81-3-6880-3770

Korea - Daegu
Tel: 82-53-744-4301

Korea - Seoul
Tel: 82-2-554-7200

Malaysia - Kuala Lumpur
Tel: 60-3-7651-7906

Malaysia - Penang
Tel: 60-4-227-8870

Philippines - Manila
Tel: 63-2-634-9065

Singapore
Tel: 65-6334-8870

Taiwan - Hsin Chu
Tel: 886-3-577-8366

Taiwan - Kaohsiung
Tel: 886-7-213-7830

Taiwan - Taipei
Tel: 886-2-2508-8600

Thailand - Bangkok
Tel: 66-2-694-1351

Vietnam - Ho Chi Minh
Tel: 84-28-5448-2100

EUROPE

Austria - Wels
Tel: 43-7242-2244-39
Fax: 43-7242-2244-393

Denmark - Copenhagen
Tel: 45-4450-2828
Fax: 45-4485-2829

Finland - Espoo
Tel: 358-9-4520-820

France - Paris
Tel: 33-1-69-53-63-20
Fax: 33-1-69-30-90-79

Germany - Garching
Tel: 49-8931-9700

Germany - Haan
Tel: 49-2129-3766400

Germany - Heilbronn
Tel: 49-7131-67-3636

Germany - Karlsruhe
Tel: 49-721-625370

Germany - Munich
Tel: 49-89-627-144-0
Fax: 49-89-627-144-44

Germany - Rosenheim
Tel: 49-8031-354-560

Israel - Ra'anana
Tel: 972-9-744-7705

Italy - Milan
Tel: 39-0331-742611
Fax: 39-0331-466781

Italy - Padova
Tel: 39-049-7625286

Netherlands - Drunen
Tel: 31-416-690399
Fax: 31-416-690340

Norway - Trondheim
Tel: 47-7288-4388

Poland - Warsaw
Tel: 48-22-3325737

Romania - Bucharest
Tel: 40-21-407-87-50

Spain - Madrid
Tel: 34-91-708-08-90
Fax: 34-91-708-08-91

Sweden - Gothenberg
Tel: 46-31-704-60-40

Sweden - Stockholm
Tel: 46-8-5090-4654

UK - Wokingham
Tel: 44-118-921-5800
Fax: 44-118-921-5820

Looking for pricing, stock, or lifecycle information?

Click below to explore more details on WIN SOURCE:

- ⊖ [View LAN83C185-JT on WIN SOURCE](#)
- ⊖ [Microchip Technology](#) Information

Optimize Your Supply Chain with WIN SOURCE Solutions

- ✓ Global Sourcing Solution
- ✓ Obsolete Management
- ✓ Cost Control Management
- ✓ Shortage Management
- ✓ Alternative Solution
- ✓ Excess Inventory Management