



THE DATASHEET OF L9953XPTR



Door actuator driver

Features

- One full bridge for 6A load ($R_{on}=150m\Omega$)
- Three half bridges for 1.5A load ($R_{on}=800m\Omega$)
- One highside driver for 6A load ($R_{on}=100m\Omega$)
- Two highside drivers for 1.5A load ($R_{on}=800m\Omega$)
- Programmable softstart function to drive loads with higher inrush currents (i.e. current $>6A$, $>1.5A$)
- Very low current consumption in stand-by mode ($I_S < 6\mu A$ typ; $T_j \leq 85^\circ C$)
- All outputs short circuit protected
- Current monitor output for highside OUT1, OUT4, OUT5 and OUT8
- All outputs over temperature protected
- Open load diagnostic for all outputs
- Overload diagnostic for all outputs
- Separated half bridges for door lock motor
- PWM control of all outputs
- Charge pump output for reverse polarity protection

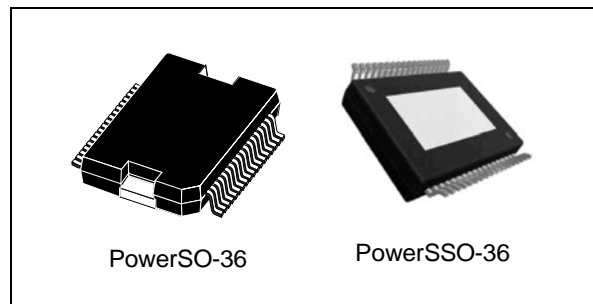

Applications

- Door actuator driver with bridges for door lock , mirror axis control, mirror fold and highside driver for mirror defroster and two 10W-light bulbs.

Description

The L9953 and L9953XP are microcontroller driven multifunctional door actuator driver for automotive applications. Up to three DC motors and three grounded resistive loads can be driven with five half bridges and three highside drivers. The integrated standard serial peripheral interface (SPI) controls all operation modes (forward, reverse, brake and high impedance). All diagnostic informations are available via SPI.

Table 1. Device summary

| Package | Order codes | |
|-------------|-------------|---------------|
| | Tube | Tape and reel |
| PowerSO-36 | L9953 | L9953TR |
| PowerSSO-36 | L9953XP | L9953XPTR |

Contents

| | | |
|----------|---|-----------|
| 1 | Block diagram and pin description | 6 |
| 2 | Electrical specifications | 9 |
| 2.1 | Absolute maximum ratings | 9 |
| 2.2 | ESD protection | 9 |
| 2.3 | Thermal data | 9 |
| 2.4 | Electrical characteristics | 10 |
| 2.5 | SPI - electrical characteristics | 14 |
| 3 | Application information | 19 |
| 3.1 | Dual power supply: VS and VCC | 19 |
| 3.2 | Standby mode | 19 |
| 3.3 | Inductive loads | 19 |
| 3.4 | Diagnostic functions | 19 |
| 3.5 | Overvoltage and under voltage detection | 20 |
| 3.6 | Charge pump | 20 |
| 3.7 | Temperature warning and thermal shutdown | 20 |
| 3.8 | Open load detection | 20 |
| 3.9 | Over load detection | 20 |
| 3.10 | Current monitor | 21 |
| 3.11 | PWM inputs | 21 |
| 3.12 | Cross-current protection | 21 |
| 3.13 | Programmable softstart function to drive loads with higher inrush current | 21 |
| 4 | Functional description of the SPI | 23 |
| 4.1 | Serial Peripheral Interface (SPI) | 23 |
| 4.2 | Chip Select Not (CSN) | 23 |
| 4.3 | Serial Data In (DI) | 23 |
| 4.4 | Serial Data Out (DO) | 24 |
| 4.5 | Serial clock (CLK) | 24 |
| 4.6 | Input data register | 24 |
| 4.7 | Status register | 24 |

| | | |
|----------|--|-----------|
| 4.8 | Scan mode | 24 |
| 4.9 | Test mode | 25 |
| 4.10 | SPI - input data and Status registers | 26 |
| 5 | Packages thermal data | 30 |
| 6 | Package and packing information | 31 |
| 6.1 | ECOPACK [®] packages | 31 |
| 6.2 | PowerSO-36 [™] package information | 31 |
| 6.3 | PowerSSO-36 [™] package information | 33 |
| 6.4 | PowerSO-36 [™] packing information | 34 |
| 6.5 | PowerSSO-36 [™] packing information | 36 |
| 7 | Revision history | 37 |

List of tables

| | | |
|-----------|--|----|
| Table 1. | Device summary | 1 |
| Table 2. | Pin definitions and functions | 6 |
| Table 3. | Absolute maximum ratings | 9 |
| Table 4. | ESD protection | 9 |
| Table 5. | Operating junction temperature | 9 |
| Table 6. | Temperature warning and thermal shutdown | 10 |
| Table 7. | Supply | 10 |
| Table 8. | Overvoltage and under voltage detection | 11 |
| Table 9. | Current monitor output | 11 |
| Table 10. | Charge pump output | 11 |
| Table 11. | OUT1 - OUT8 | 12 |
| Table 12. | Delay time from standby to active mode | 14 |
| Table 13. | Inputs: CSN, CLK, PWM1/2 and DI | 14 |
| Table 14. | DI timing | 14 |
| Table 15. | DO | 15 |
| Table 16. | DO timing | 15 |
| Table 17. | CSN timing | 15 |
| Table 18. | Test mode | 25 |
| Table 19. | SPI - input data and Status registers 0 | 26 |
| Table 20. | SPI - input data and status registers 1 | 28 |
| Table 21. | PowerSO-36™ mechanical data | 32 |
| Table 22. | PowerSSO-36™ mechanical data | 33 |
| Table 23. | Document revision history | 37 |

List of figures

| | | |
|------------|--|----|
| Figure 1. | Block diagram | 6 |
| Figure 2. | Configuration diagram (top view) | 8 |
| Figure 3. | SPI - transfer timing diagram | 16 |
| Figure 4. | SPI - input timing | 16 |
| Figure 5. | SPI - DO valid data delay time and valid time | 17 |
| Figure 6. | SPI - DO enable and disable time | 17 |
| Figure 7. | SPI - driver turn-on/off timing, minimum CSN hi time | 18 |
| Figure 8. | SPI - timing of status bit 0 (fault condition) | 18 |
| Figure 9. | Example of programmable softstart function for inductive loads | 22 |
| Figure 10. | Packages thermal data | 30 |
| Figure 11. | PowerSO-36™ package dimensions | 31 |
| Figure 12. | PowerSSO-36™ package dimensions | 33 |
| Figure 13. | PowerSO-36™ tube shipment (no suffix) | 34 |
| Figure 14. | PowerSO-36™ tape and reel shipment (suffix "TR") | 35 |
| Figure 15. | PowerSSO-36™ tube shipment (no suffix) | 36 |
| Figure 16. | PowerSSO-36™ tape and reel shipment (suffix "TR") | 36 |

1 Block diagram and pin description

Figure 1. Block diagram

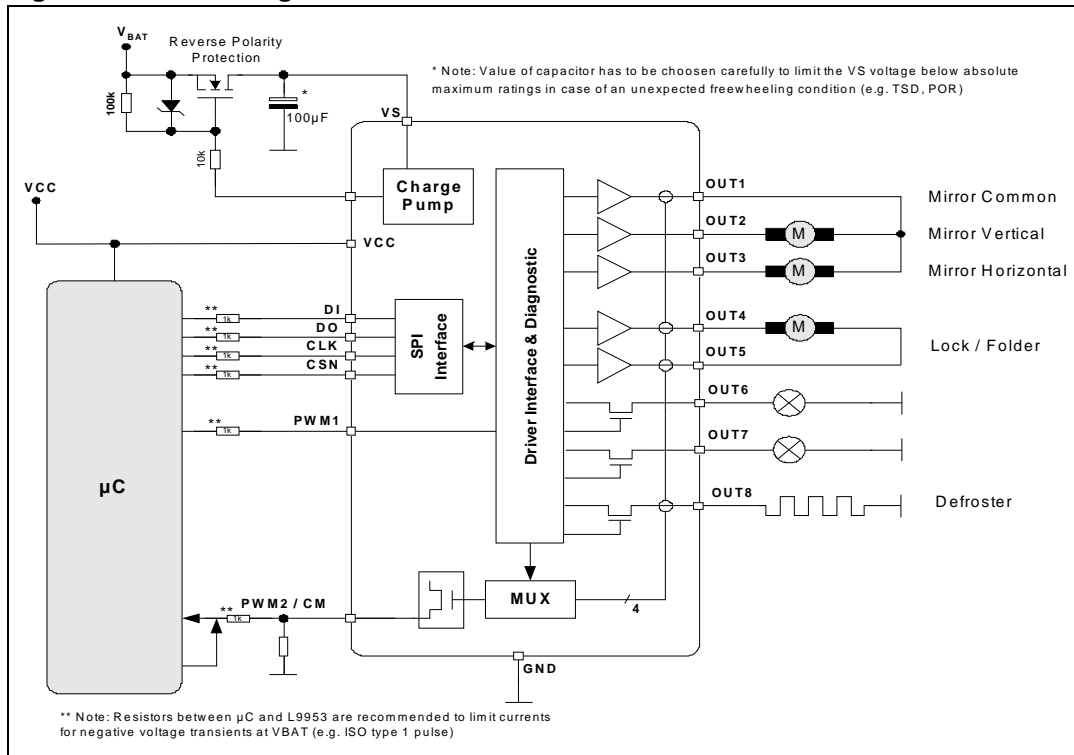

Table 2. Pin definitions and functions

| Pin | Symbol | Function |
|---------------|----------------------|---|
| 1, 18, 19, 36 | GND | Ground: Reference potential Important: for the capability of driving the full current at the outputs all pins of GND must be externally connected. |
| 2, 35 | OUT8 | Highside driver output 8 The output is built by a highside switch and is intended for resistive loads, hence the internal reverse diode from GND to the output is missing. For ESD reason a diode to GND is present but the energy which can be dissipated is limited. The highside driver is a power DMOS transistor with an internal parasitic reverse diode from the output to VS (bulk-drain-diode). The output is over-current and open load protected. Important: for the capability of driving the full current at the outputs both pins of OUT8 must be externally connected. |
| 3 4 5 | OUT1 OUT2 OUT3 | Half-bridge-output 1,2,3 The output is built by a highside and a lowside switch, which are internally connected. The output stage of both switches is a power DMOS transistor. Each driver has an internal parasitic reverse diode (bulk-drain-diode: highside driver from output to VS, lowside driver from GND to output). This output is over-current and open load protected. |

Table 2. Pin definitions and functions (continued)

| Pin | Symbol | Function |
|---------------------------------|--------------|---|
| 6, 7, 14, 15, 23, 25, 28, 32 | VS | Power supply voltage (external reverse protection required) For this input a ceramic capacitor as close as possible to GND is recommended. Important: for the capability of driving the full current at the outputs all pins of VS must be externally connected. |
| 8 | DI | Serial data input The input requires CMOS logic levels and receives serial data from the microcontroller. The data is an 24bit control word and the least significant bit (LSB, bit 0) is transferred first. |
| 9 | CM/PWM2 | Current monitor output/PWM2 input Depending on the selected multiplexer bits of Input Data Register this output sources an image of the instant current through the corresponding highside driver with a ratio of 1/10.000. This pin is bidirectional. The microcontroller can overdrive the current monitor signal to provide a second PWM input for the output OUT7. |
| 10 | CSN | Chip select not input / test mode This input is low active and requires CMOS logic levels. The serial data transfer between L9953 and micro controller is enabled by pulling the input CSN to low level. If an input voltage of more than 7.5V is applied to CSN pin the L9953 will be switched into a test mode. |
| 11 | DO | Serial data output The diagnosis data is available via the SPI and this tristate-output. The output will remain in tristate, if the chip is not selected by the input CSN (CSN = high) |
| 12 | VCC | Logic supply voltage For this input a ceramic capacitor as close as possible to GND is recommended. |
| 13 | CLK | Serial clock input This input controls the internal shift register of the SPI and requires CMOS logic levels. |
| 16,17, 20,21, | OUT4 OUT5 | Half-bridge-output 4,5: see OUT1 (pin 3). Important: for the capability of driving the full current at the outputs both pins of OUT4 (OUT5, respectively) must be externally connected. |
| 26 | CP | Charge pump output This output is provided to drive the gate of an external n-channel power MOS used for reverse polarity protection |
| 27 | PWM1 | PWM1 input: This input signal can be used to control the drivers OUT1-OUT6 and OUT8 by an external PWM signal. |

Table 2. Pin definitions and functions (continued)

| Pin | Symbol | Function |
|-----------------------|---------------|--|
| 31 33 | OUT6, OUT7 | Highside driver output 6,7: Each output is built by a highside switch and is intended for resistive loads, hence the internal reverse diode from GND to the output is missing. For ESD reason a diode to GND is present but the energy which can be dissipated is limited. Each highside driver is a power DMOS transistor with an internal parasitic reverse diode from each output to VS (bulk-drain-diode). Each output is over-current and open load protected. |
| 22, 24, 29, 30, 34 | NC | Not connected pins. |

Figure 2. Configuration diagram (top view)

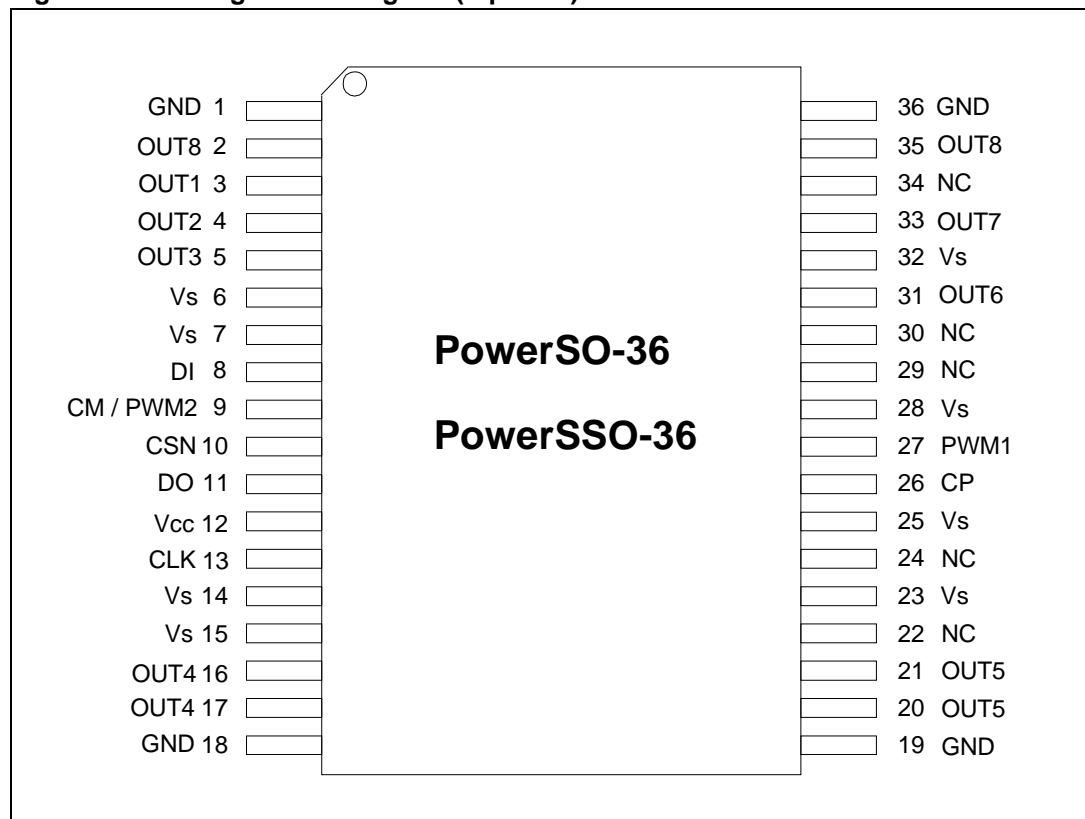

2 Electrical specifications

2.1 Absolute maximum ratings

Stressing the device above the rating listed in the “Absolute maximum ratings” table may cause permanent damage to the device. These are stress ratings only and operation of the device at these or any other conditions above those indicated in the operating sections of this specification is not implied. Exposure to absolute maximum rating conditions for extended periods may affect device reliability. Refer also to the STMicroelectronics SURE Program and other relevant quality document

Table 3. Absolute maximum ratings

| Symbol | Parameter | Value | Unit |
|---|---|------------------------|------|
| V_S | DC supply voltage | -0.3 to 28 | V |
| | Single pulse $t_{max} < 400ms$ | 40 | V |
| V_{CC} | Stabilized supply voltage, logic supply | -0.3 to 5.5 | V |
| $V_{DI}, V_{DO}, V_{CLK},$ V_{CSN}, V_{pwm1} | Digital input / output voltage | -0.3 to $V_{CC} + 0.3$ | V |
| V_{CM} | Current monitor output | -0.3 to $V_{CC} + 0.3$ | V |
| V_{CP} | Charge pump output | -25 to $V_S + 11$ | V |
| $I_{OUT1,2,3,6,7}$ | Output current | ± 5 | A |
| $I_{OUT4,5,8}$ | Output current | ± 10 | A |

2.2 ESD protection

Table 4. ESD protection

| Parameter | Value | Unit |
|--------------------------|---------------|------|
| All pins | $\pm 2^{(1)}$ | kV |
| Output pins: OUT1 - OUT8 | $\pm 8^{(2)}$ | kV |

1. HBM according to MIL 883C, Method 3015.7 or EIA/JESD22-A114-A.

2. HBM with all unzapped pins grounded.

2.3 Thermal data

Table 5. Operating junction temperature

| Symbol | Parameter | Value | Unit |
|--------|--------------------------------|------------|------|
| T_j | Operating junction temperature | -40 to 150 | °C |

Table 6. Temperature warning and thermal shutdown

| Symbol | Parameter | | Min. | Typ. | Max. | Unit |
|----------------|--|---------------------|------|------|------|------|
| $T_{jTW\ ON}$ | Temperature warning threshold junction temperature | T_j | 130 | | 150 | °C |
| $T_{jSD\ ON}$ | Thermal shutdown threshold junction temperature | T_j increasing | | | 170 | °C |
| $T_{jSD\ OFF}$ | Thermal shutdown threshold junction temperature | T_j decreasing | 150 | | | °C |
| $T_{jSD\ HYS}$ | Thermal shutdown hysteresis | | | 5 | | °K |

2.4 Electrical characteristics

$V_S = 8$ to $16V$, $V_{CC} = 4.5$ to $5.3V$, $T_j = -40$ to $150^\circ C$, unless otherwise specified.

The voltages are referred to GND and currents are assumed positive, when the current flows into the pin.

Table 7. Supply

| Symbol | Parameter | Test condition | Min. | Typ. | Max. | Unit |
|----------------|-----------------------------------|---|------|------|------|---------|
| V_S | Operating supply voltage range | | 7 | | 28 | V |
| I_S | V_S DC supply current | $V_S = 16V$, $V_{CC} = 5.3V$ active mode OUT1 - OUT8 floating | | 7 | 20 | mA |
| | V_S quiescent supply current | $V_S = 16V$, $V_{CC} = 0V$ standby mode OUT1 - OUT8 floating $T_{test} = -40^\circ C, 25^\circ C$ | | 4 | 12 | μA |
| | | $T_{test} = 85^\circ C^{(1)}$ | | | 6 | 25 |
| I_{CC} | V_{CC} DC supply current | $V_S = 16V$, $V_{CC} = 5.3V$ $CSN = V_{CC}$, active mode | | 1 | 3 | mA |
| | V_{CC} quiescent supply current | $V_S = 16V$, $V_{CC} = 5.3V$ $CSN = V_{CC}$ standby mode OUT1 - OUT8 floating | | 25 | 50 | μA |
| $I_S + I_{CC}$ | Sum quiescent supply current | $V_S = 16V$, $V_{CC} = 5.3V$ $CSN = V_{CC}$ standby mode OUT1 - OUT8 floating $T_{test} = 130^\circ C$ | | 50 | 100 | μA |

1. Guaranteed by design.

Table 8. Overvoltage and under voltage detection

| Symbol | Parameter | Test condition | Min. | Typ. | Max | Unit |
|-----------------|---------------------------|------------------------------|------|------|------|------|
| $V_{SUV\ ON}$ | VS UV-threshold voltage | V_S increasing | 5.7 | | 7.2 | V |
| $V_{SUV\ OFF}$ | VS UV-threshold voltage | V_S decreasing | 5.5 | | 6.9 | V |
| $V_{SUV\ hyst}$ | VS UV-hysteresis | $V_{SUV\ ON} - V_{SUV\ OFF}$ | | 0.5 | | V |
| $V_{SOV\ OFF}$ | VS OV-threshold voltage | V_S increasing | 18 | | 24.5 | V |
| $V_{SOV\ ON}$ | VS OV-threshold voltage | V_S decreasing | 17.5 | | 23.5 | V |
| $V_{SOV\ hyst}$ | VS OV-hysteresis | $V_{SOV\ OFF} - V_{SOV\ ON}$ | | 1 | | V |
| $V_{POR\ OFF}$ | Power-On-reset threshold | V_{CC} increasing | | | 4.4 | V |
| $V_{POR\ ON}$ | Power-On-reset threshold | V_{CC} decreasing | 3.1 | | | V |
| $V_{POR\ hyst}$ | Power-On-reset hysteresis | $V_{POR\ OFF} - V_{POR\ ON}$ | | 0.3 | | V |

Table 9. Current monitor output

| Symbol | Parameter | Test condition | Min. | Typ. | Max | Unit |
|---------------|--|---|------|--------------------|--------------|------|
| V_{CM} | Functional voltage range | $V_{CC} = 5V$ | 0 | | 4 | V |
| $I_{CM,r}$ | Current monitor output ratio: $I_{CM} / I_{OUT1,4,5,8}$ | $0V \leq V_{CM} \leq 4V, V_{CC}=5V$ | | $\frac{1}{10.000}$ | | - |
| $I_{CM\ acc}$ | Current monitor accuracy | $0V \leq V_{CM} \leq 3.8V,$ $V_{CC} = 5V, I_{Out,min}=500mA,$ $I_{Out\ max} = 6A$ (FS = full scale= 600 μ A) | | 4% + 1%FS | 8% + 2%FS | - |

Table 10. Charge pump output

| Symbol | Parameter | Test condition | Min. | Typ. | Max | Unit |
|----------|----------------------------|------------------------------------|----------|------|----------|---------|
| V_{CP} | Charge pump output voltage | $V_S = 8V, I_{CP} = -60\mu A$ | V_S+6 | | V_S+13 | V |
| | | $V_S = 10V, I_{CP} = -80\mu A$ | V_S+8 | | V_S+13 | V |
| | | $V_S \geq 12V, I_{CP} = -100\mu A$ | V_S+10 | | V_S+13 | V |
| I_{CP} | Charge pump output current | $V_{CP} = V_S+10V, V_S = 13.5V$ | 95 | 150 | 300 | μA |

Table 11. OUT1 - OUT8

| Symbol | Parameter | Test condition | Min. | Typ. | Max | Unit |
|--|--|--|-------|------|------|------------------|
| $r_{ON\ OUT1}$, $r_{ON\ OUT2}$ $r_{ON\ OUT3}$ | On-resistance to supply or GND | $V_S = 13.5\text{ V}$, $T_j = 25\text{ }^\circ\text{C}$, $I_{OUT1,2,3} = \pm 0.8\text{ A}$ | | 800 | 1100 | $\text{m}\Omega$ |
| | | $V_S = 13.5\text{ V}$, $T_j = 125\text{ }^\circ\text{C}$, $I_{OUT1,2,3} = \pm 0.8\text{ A}$ | | 1250 | 1700 | $\text{m}\Omega$ |
| $r_{ON\ OUT4}$, $r_{ON\ OUT5}$ | On-resistance to supply or GND | $V_S = 13.5\text{ V}$, $T_j = 25\text{ }^\circ\text{C}$, $I_{OUT4,5} = \pm 3\text{ A}$ | | 150 | 200 | $\text{m}\Omega$ |
| | | $V_S = 13.5\text{ V}$, $T_j = 125\text{ }^\circ\text{C}$, $I_{OUT4,5} = \pm 3\text{ A}$ | | 225 | 300 | $\text{m}\Omega$ |
| $r_{ON\ OUT6}$, $r_{ON\ OUT7}$ | On-resistance to supply | $V_S = 13.5\text{ V}$, $T_j = 25\text{ }^\circ\text{C}$, $I_{OUT6,7} = -0.8\text{ A}$ | | 500 | 700 | $\text{m}\Omega$ |
| | | $V_S = 13.5\text{ V}$, $T_j = 125\text{ }^\circ\text{C}$, $I_{OUT6,7} = -0.8\text{ A}$ | | 700 | 950 | $\text{m}\Omega$ |
| $r_{ON\ OUT8}$ | On-resistance to supply | $V_S = 13.5\text{ V}$, $T_j = 25\text{ }^\circ\text{C}$, $I_{OUT8} = -3\text{ A}$ | | 100 | 150 | $\text{m}\Omega$ |
| | | $V_S = 13.5\text{ V}$, $T_j = 125\text{ }^\circ\text{C}$, $I_{OUT8} = -3\text{ A}$ | | 150 | 200 | $\text{m}\Omega$ |
| I_{OUT1} I_{OUT2} I_{OUT3} | Output current limitation to GND | Source, $V_S = 13.5\text{ V}$ | -3.0 | | -1.5 | A |
| I_{OUT1} I_{OUT2} I_{OUT3} | Output current limitation to supply | Sink, $V_S = 13.5\text{ V}$ | 1.5 | | 3.0 | A |
| I_{OUT4} I_{OUT5} | Output current limitation to GND | Source, $V_S = 13.5\text{ V}$ | -10.5 | | -6 | A |
| I_{OUT4} I_{OUT5} | Output current limitation to supply | Sink, $V_S = 13.5\text{ V}$ | 6 | | 10.5 | A |
| I_{OUT6} I_{OUT7} | Output current limitation to GND | Source, $V_S = 13.5\text{ V}$ | -3.0 | | -1.5 | A |
| I_{OUT8} | Output current limitation to GND | Source, $V_S = 13.5\text{ V}$ | -10.5 | | -6 | A |
| $t_{d\ ON\ H}$ | Output delay time, highside driver on | $V_S = 13.5\text{ V}$, corresponding lowside driver is not active | 20 | 40 | 80 | μs |
| $t_{d\ OFF\ H}$ | Output delay time, highside driver off | $V_S = 13.5\text{ V}$ | 50 | 150 | 300 | μs |
| $t_{d\ ON\ L}$ | Output delay time, lowside driver on | $V_S = 13.5\text{ V}$, corresponding highside driver is not active | 15 | 30 | 70 | μs |
| $t_{d\ OFF\ L}$ | Output delay time, lowside driver off | $V_S = 13.5\text{ V}$ | 60 | 100 | 200 | μs |

Table 11. OUT1 - OUT8 (continued)

| Symbol | Parameter | Test condition | Min. | Typ. | Max | Unit |
|-------------------------------------|---|--|------|------|------|------------|
| t_{dHL} | Cross current protection time, source to sink | $t_{CC ONLS_OFFHS} - t_{d OFF H}^{(1)}$ | | 200 | 400 | μs |
| t_{dLH} | Cross current protection time, sink to source | $t_{CC ONHS_OFFLS} - t_{d OFF L}^{(1)}$ | | 200 | 400 | μs |
| I_{QLH} | Switched-off output current highside drivers of OUT1-8 | $V_{OUT1-8}=0V$, standby mode | 0 | -2 | -5 | μA |
| | | $V_{OUT1-8}=0V$, active mode | -40 | -15 | 0 | μA |
| I_{QLL} | Switched-off output current lowside drivers of OUT1-5 | $V_{OUT1-5}=V_S$, standby mode | 0 | 80 | 120 | μA |
| | | $V_{OUT1-5}=V_S$, active mode | -40 | -15 | 0 | μA |
| I_{OLD123} | Open load detection current of OUT1, OUT2 and OUT3 | Source and sink | 15 | 40 | 60 | mA |
| I_{OLD45} | Open load detection current of OUT4 and OUT5 | Source and sink | 60 | 150 | 300 | mA |
| I_{OLD67} | Open load detection current of OUT6 and OUT7 | Source | 15 | 40 | 60 | mA |
| I_{OLD8} | Open load detection current of OUT8 | Source | 30 | 150 | 300 | mA |
| t_{dOL} | Minimum duration of open load condition to set the status bit | | 500 | | 3000 | μs |
| t_{ISC} | Minimum duration of over-current condition to switch off the driver | | 10 | | 100 | μs |
| f_{rec0} | Recovery frequency for OC recovery duty cycle bit=0 | | 2 | | 8 | kHz |
| f_{rec1} | Recovery frequency for OC recovery duty cycle bit=1 | | 3 | | 16 | kHz |
| dV_{OUT123}/dt dV_{OUT67}/dt | Slew rate of OUT ₁₂₃ and OUT ₆₇ | $V_S = 13.5 V$ $R_{load} = 16.8 \Omega$ | 0.08 | 0.2 | 0.4 | V/ μs |
| dV_{OUT45}/dt | Slew rate of OUT ₄ and OUT ₅ | $V_S = 13.5 V$ $R_{load} = 4.5 \Omega$ | 0.08 | 0.2 | 0.4 | V/ μs |
| dV_{OUT8}/dt | Slew rate of OUT ₈ | $V_S = 13.5 V$ $R_{load} = 4.5 \Omega$ | 0.08 | 0.2 | 0.4 | V/ μs |

1. $t_{CC ON}$ is the switch on delay time $t_{d ON}$ if complement in half bridge has to switch Off.

2.5 SPI - electrical characteristics

($V_S = 8$ to $16V$, $V_{CC} = 4.5$ to $5.3V$, $T_j = -40$ to $150^\circ C$, unless otherwise specified. The voltages are referred to GND and currents are assumed positive, when the current flows into the pin).

Table 12. Delay time from standby to active mode

| Symbol | Parameter | Test condition | Min. | Typ. | Max. | Unit |
|-----------|------------|---|------|------|------|---------|
| t_{set} | Delay time | Switching from standby to active mode. Time until output drivers are enabled | | 160 | 300 | μs |

Table 13. Inputs: CSN, CLK, PWM1/2 and DI

| Symbol | Parameter | Test condition | Min. | Typ. | Max. | Unit |
|----------------|--|--------------------------------|------|------|------|---------|
| V_{inL} | Input low level | $V_{CC} = 5V$ | 1.5 | 2.0 | | V |
| V_{inH} | Input high level | $V_{CC} = 5V$ | | 3.0 | 3.5 | V |
| V_{inHyst} | Input hysteresis | $V_{CC} = 5V$ | 0.5 | | | V |
| $I_{CSN\ in}$ | Pull up current at input CSN | $V_{CSN} = 3.5V$ $V_{CC} = 5V$ | -40 | -20 | -5 | μA |
| $I_{CLK\ in}$ | Pull down current at input CLK | $V_{CLK} = 1.5V$ | 10 | 25 | 50 | μA |
| $I_{DI\ in}$ | Pull down current at input DI | $V_{DI} = 1.5V$ | 10 | 25 | 50 | μA |
| $I_{PWM1\ in}$ | Pull down current at input PWM1 | $V_{PWM} = 1.5V$ | 10 | 25 | 50 | μA |
| $C_{in}^{(1)}$ | Input capacitance at input CSN, CLK, DI and PWM1/2 | $0V < V_{CC} < 5.3V$ | | 10 | 15 | pF |

1. Value of input capacity is not measured in production test. Parameter guaranteed by design.

Table 14. DI timing⁽¹⁾

| Symbol | Parameter | Test condition | Min. | Typ. | Max. | Unit |
|------------------|--|----------------|------|------|------|------|
| t_{CLK} | Clock period | $V_{CC} = 5V$ | 1000 | | | ns |
| t_{CLKH} | Clock high time | $V_{CC} = 5V$ | 400 | | | ns |
| t_{CLKL} | Clock low time | $V_{CC} = 5V$ | 400 | | | ns |
| $t_{set\ CSN}$ | CSN setup time, CSN low before rising edge of CLK | $V_{CC} = 5V$ | 400 | | | ns |
| $t_{set\ CLK}$ | CLK setup time, CLK high before rising edge of CSN | $V_{CC} = 5V$ | 400 | | | ns |
| $t_{set\ DI}$ | DI setup time | $V_{CC} = 5V$ | 200 | | | ns |
| $t_{hold\ time}$ | DI hold time | $V_{CC} = 5V$ | 200 | | | ns |
| $t_{r\ in}$ | Rise time of input signal DI, CLK, CSN | $V_{CC} = 5V$ | | | 100 | ns |
| $t_{f\ in}$ | Fall time of input signal DI, CLK, CSN | $V_{CC} = 5V$ | | | 100 | ns |

1. DI timing parameters tested in production by a passed / failed test:

$T_j = -40^\circ C / +25^\circ C$: SPI communication @ 2MHz.

$T_j = +125^\circ C$: SPI communication @ 1.25 MHz.

Table 15. DO

| Symbol | Parameter | Test condition | Min. | Typ. | Max. | Unit |
|----------------|----------------------------|--|----------------|----------------|------|---------------|
| V_{DOL} | Output low level | $V_{CC} = 5\text{ V}$, $I_D = -2\text{ mA}$ | | 0.2 | 0.4 | V |
| V_{DOH} | Output high level | $V_{CC} = 5\text{ V}$, $I_D = 2\text{ mA}$ | $V_{CC} - 0.4$ | $V_{CC} - 0.2$ | | V |
| I_{DOLK} | Tristate leakage current | $V_{CSN} = V_{CC}$, $0\text{ V} < V_{DO} < V_{CC}$ | -10 | | 10 | μA |
| $C_{DO}^{(1)}$ | Tristate input capacitance | $V_{CSN} = V_{CC}$, $0\text{ V} < V_{CC} < 5.3\text{ V}$ | | 10 | 15 | pF |

1. Value of input capacity is not measured in production test. Parameter guaranteed by design.

Table 16. DO timing

| Symbol | Parameter | Test condition | Min. | Typ. | Max. | Unit |
|-----------------------|---|--|------|------|------|------|
| $t_{r\ DO}$ | DO rise time | $C_L = 100\text{ pF}$, $I_{load} = -1\text{ mA}$ | | 80 | 140 | ns |
| $t_{f\ DO}$ | DO fall time | $C_L = 100\text{ pF}$, $I_{load} = 1\text{ mA}$ | | 50 | 100 | ns |
| $t_{en\ DO\ tri\ L}$ | DO enable time from tristate to low level | $C_L = 100\text{ pF}$, $I_{load} = 1\text{ mA}$ pull-up load to V_{CC} | | 100 | 250 | ns |
| $t_{dis\ DO\ L\ tri}$ | DO disable time from low level to tristate | $C_L = 100\text{ pF}$, $I_{load} = 4\text{ mA}$ pull-up load to V_{CC} | | 380 | 450 | ns |
| $t_{en\ DO\ tri\ H}$ | DO enable time from tristate to high level | $C_L = 100\text{ pF}$, $I_{load} = -1\text{ mA}$ pull-down load to GND | | 100 | 250 | ns |
| $t_{dis\ DO\ H\ tri}$ | DO disable time from high level to tristate | $C_L = 100\text{ pF}$, $I_{load} = -4\text{ mA}$ pull-down load to GND | | 380 | 450 | ns |
| $t_{d\ DO}$ | DO delay time | $V_{DO} < 0.3 V_{CC}$, $V_{DO} > 0.7 V_{CC}$, $C_L = 100\text{ pF}$ | | 50 | 250 | ns |

Table 17. CSN timing

| Symbol | Parameter | Test condition | Min. | Typ. | Max. | Unit |
|--------------------|--|---|------|------|------|---------------|
| $t_{CSN_HI, stb}$ | CSN HI time, switching from standby mode | Transfer of SPI-command to Input Register | 20 | | | μs |
| $t_{CSN_HI, min}$ | CSN HI time, active mode | Transfer of SPI-command to input register | 4 | | | μs |

Figure 3. SPI - transfer timing diagram

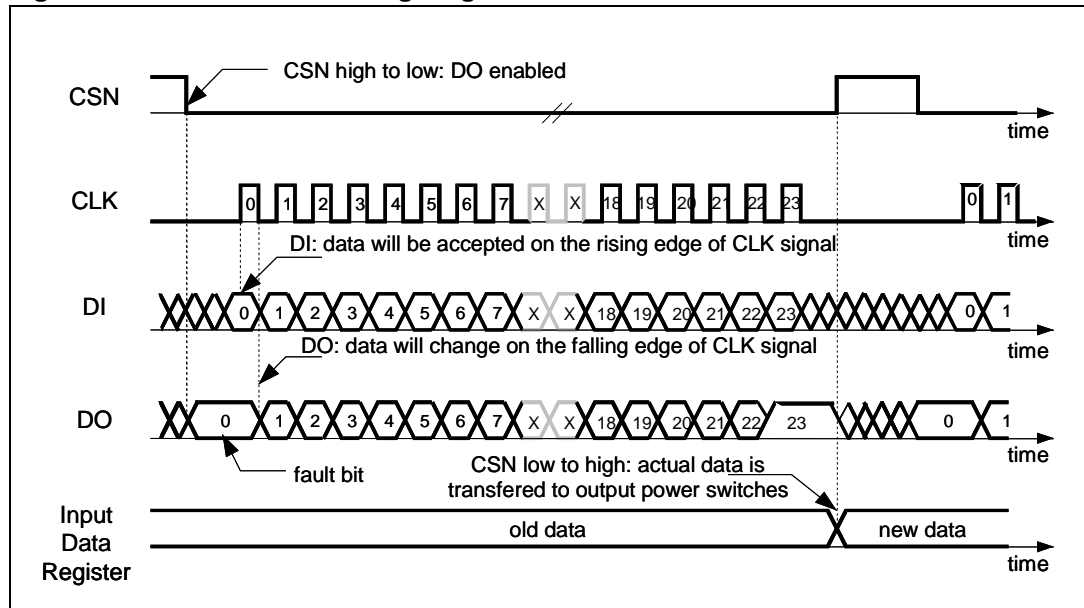

Figure 4. SPI - input timing

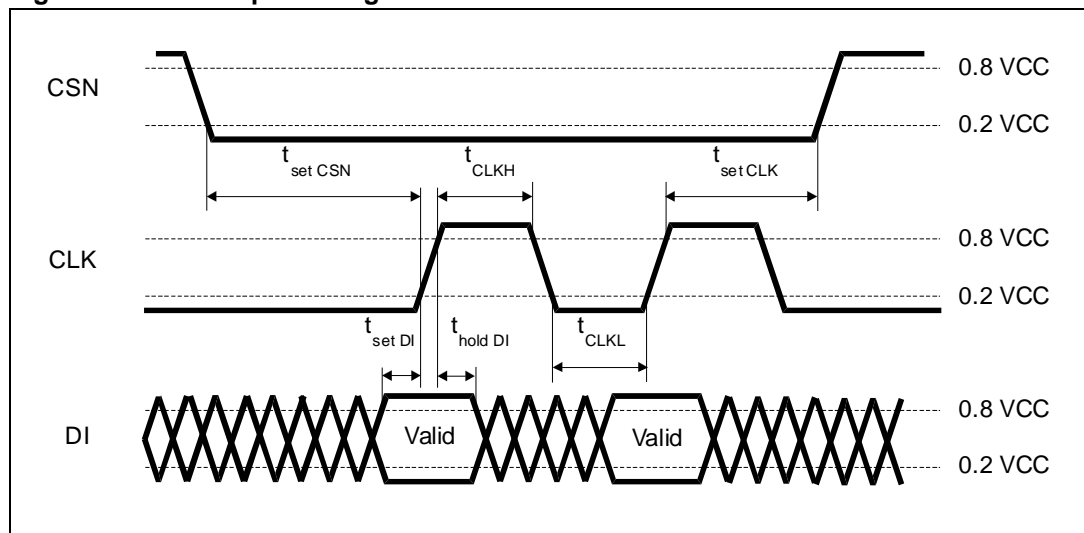

Figure 5. SPI - DO valid data delay time and valid time

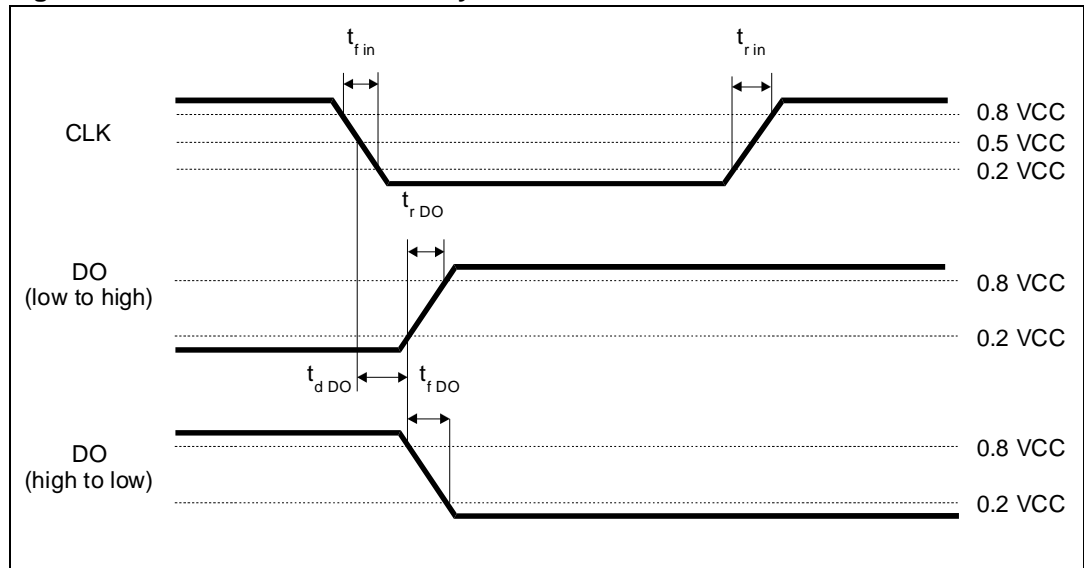

Figure 6. SPI - DO enable and disable time

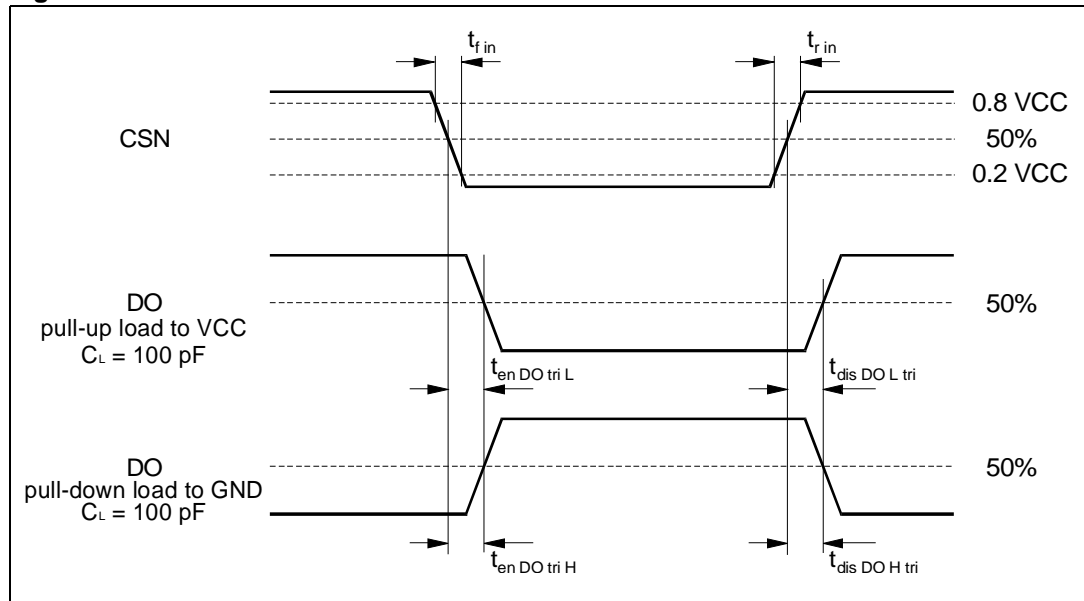

Figure 7. SPI - driver turn-on/off timing, minimum CSN hi time

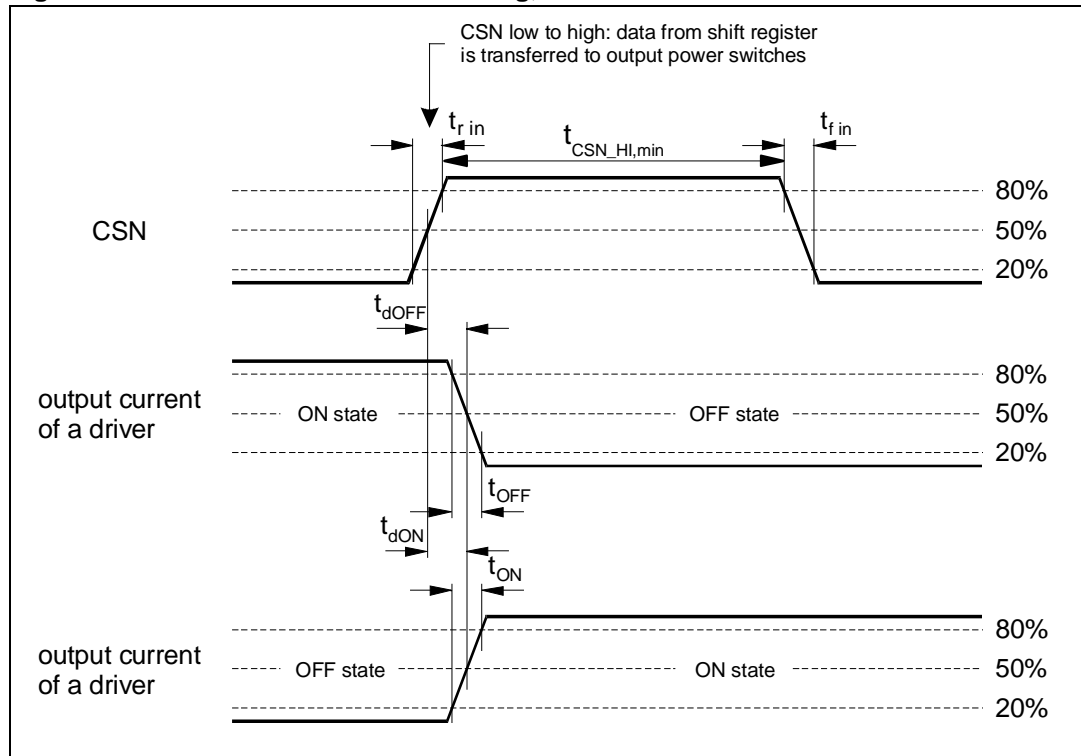
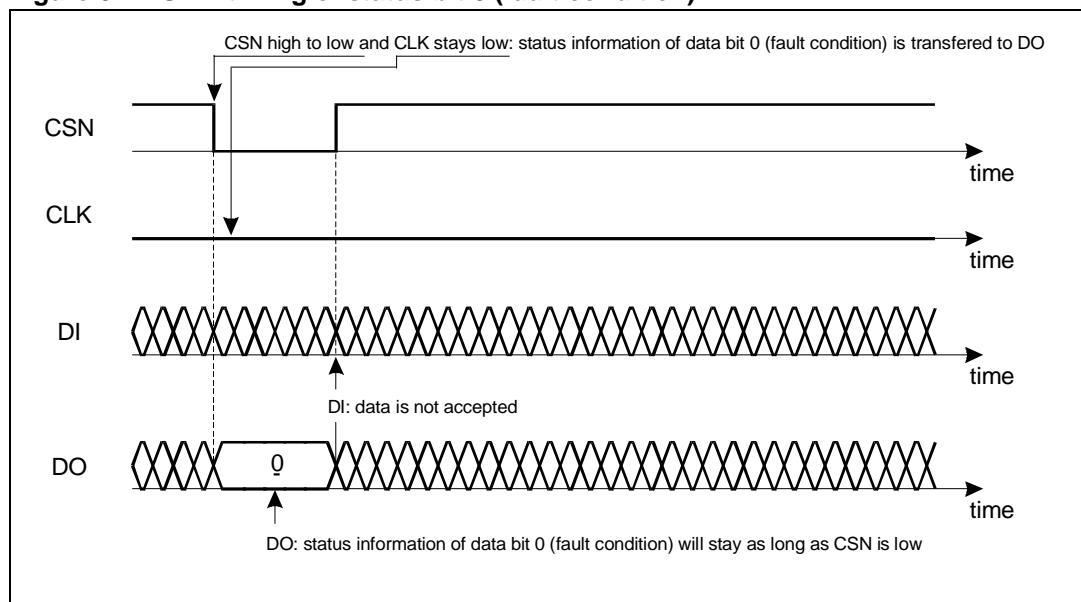

Figure 8. SPI - timing of status bit 0 (fault condition)



3 Application information

3.1 Dual power supply: V_S and V_{CC}

The power supply voltage V_S supplies the half bridges and the highside drivers. An internal charge-pump is used to drive the highside switches. The logic supply voltage V_{CC} (stabilized 5 V) is used for the logic part and the SPI of the device.

Due to the independent logic supply voltage the control and status information will not be lost, if there are temporary spikes or glitches on the power supply voltage. In case of power-on (V_{CC} increases from under voltage to $V_{POR\ OFF} = 4.2\text{ V}$) the circuit is initialized by an internally generated power-on-reset (POR). If the voltage V_{CC} decreases under the minimum threshold ($V_{POR\ ON} = 3.4\text{ V}$), the outputs are switched to tristate (high impedance) and the status registers are cleared.

3.2 Standby mode

The standby mode of the L9953 is activated by clearing the bit 23 of the Input Data Register 0. All latched data will be cleared and the inputs and outputs are switched to high impedance. In the standby mode the current at V_S (V_{CC}) is less than 6 μA (50 μA) for $CSN = \text{high}$ (DO in tristate). By switching the V_{CC} voltage a very low quiescent current can be achieved. If bit 23 is set, the device will be switched to active mode.

3.3 Inductive loads

Each half bridge is built by an internally connected highside and a lowside power DMOS transistor. Due to the built-in reverse diodes of the output transistors, inductive loads can be driven at the outputs OUT1 to OUT5 without external free-wheeling diodes. The highside drivers OUT6 to OUT8 are intended to drive resistive loads. Hence only a limited energy ($E < 1\text{ mJ}$) can be dissipated by the internal ESD-diodes in freewheeling condition. For inductive loads ($L > 100\mu\text{H}$) an external free-wheeling diode connected to GND and the corresponding output is needed.

3.4 Diagnostic functions

All diagnostic functions (over/open load, power supply over-/under voltage, temperature warning and thermal shutdown) are internally filtered and the condition has to be valid for at least 32 μs (open load: 1ms, respectively) before the corresponding status bit in the status registers will be set. The filters are used to improve the noise immunity of the device. Open load and temperature warning function are intended for information purpose and will not change the state of the output drivers. On contrary, the overload condition will disable the corresponding driver (over-current) and over temperature will switch off all drivers (thermal shutdown). Without setting the over-current recovery bits in the Input Data register, the microcontroller has to clear the over-current status bits to reactivate the corresponding drivers.

3.5 Overvoltage and under voltage detection

If the power supply voltage V_S rises above the overvoltage threshold V_{SOV_OFF} (typical 21 V), the outputs OUT1 to OUT8 are switched to high impedance state to protect the load. When the voltage V_S drops below the under voltage threshold V_{SUV_OFF} (UV-switch-OFF voltage), the output stages are switched to the high impedance to avoid the operation of the power devices without sufficient gate driving voltage (increased power dissipation). If the supply voltage V_S recovers to normal operating voltage the outputs stages return to the programmed state (input register 0: bit 20=0).

If the under voltage/overvoltage recovery disable bit is set, the automatic turn-on of the drivers is deactivated. The microcontroller needs to clear the status bits to reactivate the drivers. It is recommended to set bit 20 to avoid a possible high current oscillation in case of a shorted output to GND and low battery voltage.

3.6 Charge pump

The charge pump runs under all conditions in normal mode. In standby the charge pump is disabled.

3.7 Temperature warning and thermal shutdown

If junction temperature rises above T_{j_TW} a temperature warning flag is set and is detectable via the SPI. If junction temperature increases above the second threshold T_{j_SD} , the thermal shutdown bit will be set and power DMOS transistors of all output stages are switched off to protect the device. Temperature warning flag and thermal shutdown bit are latched and must be cleared by the microcontroller. The related bit is only cleared if the temperature decreases below the trigger temperature. If the thermal shutdown bit has been cleared the output stages are reactivated.

3.8 Open load detection

The open load detection monitors the load current in each activated output stage. If the load current is below the open load detection threshold for at least 1 ms (t_{dOL}) the corresponding open load bit is set in the status register. Due to mechanical/electrical inertia of typical loads a short activation of the outputs (e.g. 3ms) can be used to test the open load status without changing the mechanical/electrical state of the loads.

3.9 Over load detection

In case of an over-current condition a flag is set in the status register in the same way as open load detection. If the over-current signal is valid for at least $t_{ISC} = 32 \mu s$, the over-current flag is set and the corresponding driver is switched off to reduce the power dissipation and to protect the integrated circuit. If the over-current recovery bit of the output is zero the microcontroller has to clear the status bits to reactivate the corresponding driver.

3.10 Current monitor

The current monitor output sources a current image at the current monitor output which has a fixed ratio (1/10000) of the instantaneous current of the selected highside driver. The bits 18 and 19 of the Input Data Register 0 control which of the outputs OUT1, OUT4, OUT5, and OUT8 will be multiplexed to the current monitor output. The current monitor output allows a more precise analysis of the actual state of the load rather than the detection of an open- or overload condition. For example this can be used to detect the motor state (starting, free-running, stalled). Moreover, it is possible to regulate the power of the defroster more precise by measuring the load current. The current monitor output is bidirectional (c.f. PWM inputs).

3.11 PWM inputs

Each driver has a corresponding PWM enable bit which can be programmed by the SPI interface. If the PWM enable bit in Input Data Register 1 is set, the output is controlled by the logically AND-combination of the PWM signal and the output control bit in Input Data Register 0. The outputs OUT1-OUT6 and OUT8 are controlled by the PWM1 input and the output OUT7 is controlled by the bidirectional input CM/PMW2. For example, the two PWM inputs can be used to dim two lamps independently by external PWM signals.

3.12 Cross-current protection

The six half-bridges of the device are cross-current protected by an internal delay time. If one driver (LS or HS) is turned-off the activation of the other driver of the same half bridge will be automatically delayed by the cross-current protection time. After the cross-current protection time is expired the slew-rate limited switch-off phase of the driver will be changed to a fast turn-off phase and the opposite driver is turned-on with slew-rate limitation. Due to this behavior it is always guaranteed that the previously activated driver is totally turned-off before the opposite driver will start to conduct.

3.13 Programmable softstart function to drive loads with higher inrush current

Loads with start-up currents higher than the over-current limits (e.g. inrush current of lamps, start current of motors and cold resistance of heaters) can be driven by using the programmable softstart function (i.e. overcurrent recovery mode). Each driver has a corresponding over-current recovery bit. If this bit is set, the device will automatically switch-on the outputs again after a programmable recovery time. The duty cycle in over-current condition can be programmed by the SPI interface to be about 12% or 25%. The PWM modulated current will provide sufficient average current to power up the load (e.g. heat up the bulb) until the load reaches operating condition. The PWM frequency settles at 3kHz or 6kHz. The device itself cannot distinguish between a real overload and a non linear load like a light bulb. A real overload condition can only be qualified by time. As an example the microcontroller can switch on light bulbs by setting the over-current Recovery bit for the first 50ms. After clearing the recovery bit the output will be automatically disabled if the overload condition still exists.

Figure 9. Example of programmable softstart function for inductive loads

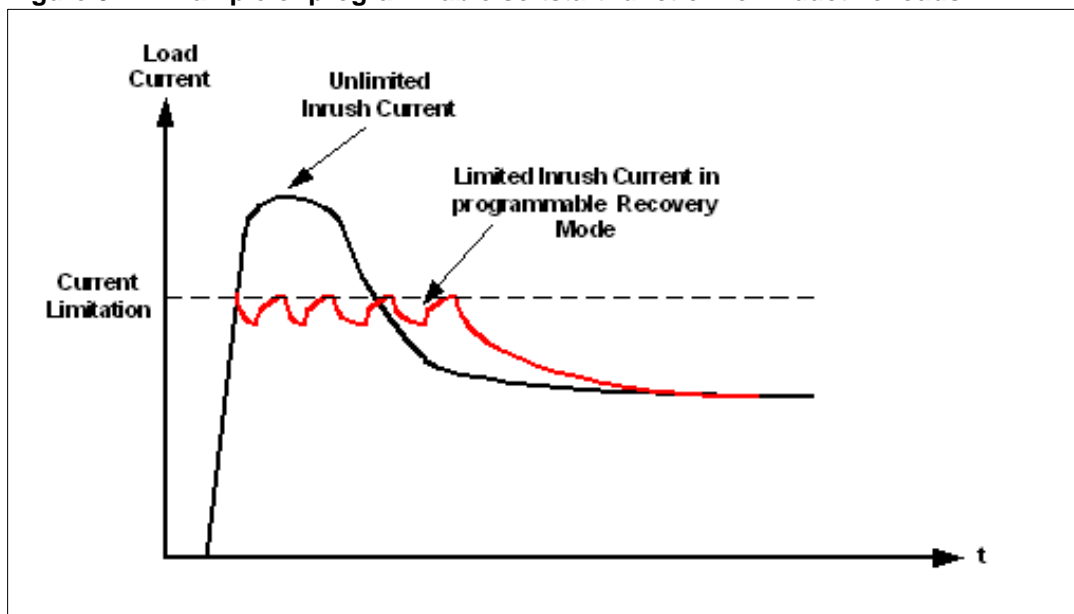

4 Functional description of the SPI

4.1 Serial Peripheral Interface (SPI)

This device uses a standard SPI to communicate with a microcontroller. The SPI can be driven by a microcontroller with its SPI peripheral running in following mode: CPOL = 0 and CPHA = 0.

For this mode, input data is sampled by the low to high transition of the clock CLK, and output data is changed from the high to low transition of CLK.

This device is not limited to microcontroller with a build-in SPI. Only three CMOS-compatible output pins and one input pin will be needed to communicate with the device. A fault condition can be detected by setting CSN to low. If CSN = 0, the DO-pin will reflect the status bit 0 (fault condition) of the device which is a logical-or of all bits in the status registers 0 and 1. The microcontroller can poll the status of the device without the need of a full SPI-communication cycle.

Note: In contrast to the SPI-standard the least significant bit (LSB) will be transferred first (see [Figure 3](#)).

4.2 Chip Select Not (CSN)

The input pin is used to select the serial interface of this device. When CSN is high, the output pin (DO) will be in high impedance state. A low signal will activate the output driver and a serial communication can be started. The state when CSN is going low until the rising edge of CSN will be called a communication frame. If the CSN-input pin is driven above 7.5V, the L9953 will go into a test mode. In the test mode the DO will go from tri-state to active mode.

4.3 Serial Data In (DI)

The input pin is used to transfer data serial into the device. The data applied to the DI will be sampled at the rising edge of the CLK signal and shifted into an internal 24 bit shift register. At the rising edge of the CSN signal the contents of the shift register will be transferred to Data Input Register. The writing to the selected Data Input Register is only enabled if exactly 24 bits are transmitted within one communication frame (i.e. CSN low). If more or less clock pulses are counted within one frame the complete frame will be ignored. This safety function is implemented to avoid an activation of the output stages by a wrong communication frame.

Note: Due to this safety functionality a daisy chaining of SPI is not possible. Instead, a parallel operation of the SPI bus by controlling the CSN signal of the connected ICs is recommended.

4.4 Serial Data Out (DO)

The data output driver is activated by a logical low level at the CSN input and will go from high impedance to a low or high level depending on the status bit 0 (fault condition). The first rising edge of the CLK input after a high to low transition of the CSN pin will transfer the content of the selected status register into the data out shift register. Each subsequent falling edge of the CLK will shift the next bit out.

4.5 Serial clock (CLK)

The CLK input is used to synchronize the input and output serial bit streams. The data input (DI) is sampled at the rising edge of the CLK and the data output (DO) will change with the falling edge of the CLK signal.

4.6 Input data register

The device has two input registers. The first bit (bit 0) at the DI-input is used to select one of the two Input Registers. All bits are first shifted into an input shift register. After the rising edge of CSN the contents of the input shift register will be written to the selected Input Data Register only if a frame of exact 24 data bits are detected. Depending on bit 0 the contents of the selected status register will be transferred to DO during the current communication frame. Bit 1-17 controls the behavior of the corresponding driver.

If bit 23 is zero, the device will go into the standby-mode. The bits 18 and 19 are used to control the current monitor multiplexer. Bit 22 is used to reset all status bits in both status registers. The bits in the status registers will be cleared after the current communication frame (rising edge of CSN).

4.7 Status register

This device uses two status registers to store and to monitor the state of the device. Bit 0 is used as a fault bit and is a logical-NOR combination of bits 1-22 in both status registers. The state of this bit can be polled by the microcontroller without the need of a full SPI-communication cycle. If one of the over-current bits is set, the corresponding driver will be disabled. If the over-current recovery bit of the output is not set the microcontroller has to clear the over-current bit to enable the driver. If the thermal shutdown bit is set, all drivers will go into a high impedance state. Again the microcontroller has to clear the bit to enable the drivers.

4.8 Scan mode

The Scan Mode can be entered by rising the PWM1 input to a voltage higher than 9.5V.

4.9 Test mode

The Test Mode can be entered by rising the CSN input to a voltage higher than 9.5V. In the test mode the inputs CLK, DI, PWM1/2, the internal 2MHz CLK, OL and OC can be multiplexed to output DO and Iref, Tsens1-4 and Vbgp can be multiplexed to input CM/PWM2.

Furthermore the over-current thresholds are reduced by a factor of 4 to allow EWS testing at lower current.

The internal logic prevents that the High-Side and Low-Side driver of the same half-bridge can be switched-on at the same time. In the test mode this combination is used to multiplex the desired signals according to following table:

Table 18. Test mode

| OUT1 PWM 1 EN | OUT2 PWM 1 EN | OUT3 PWM 1 EN | OUT4 PWM 1 EN | OUT5 PWM 1 EN | OUT6 PWM 1 EN | DO | LS3 | HS3 | LS4 | HS4 | LS5 | HS5 | Test Pad |
|---------------------|---------------------|---------------------|---------------------|---------------------|---------------------|---------|-------------|-------------|-------------|-------------|-------------|-------------|----------|
| ! (both HI) | ! (both HI) | ! (both HI) | ! (both HI) | ! (both HI) | ! (both HI) | NoError | ! (both HI) | ! (both HI) | ! (both HI) | ! (both HI) | ! (both HI) | ! (both HI) | 5μA Iref |
| both HI | ! (both HI) | ! (both HI) | ! (both HI) | ! (both HI) | ! (both HI) | DI | both HI | ! (both HI) | ! (both HI) | ! (both HI) | ! (both HI) | ! (both HI) | Tsens1 |
| ! (both HI) | both HI | both HI | ! (both HI) | ! (both HI) | ! (both HI) | CLK | ! (both HI) | both HI | both HI | ! (both HI) | ! (both HI) | ! (both HI) | Tsens2 |
| both HI | both HI | both HI | ! (both HI) | ! (both HI) | ! (both HI) | INT_CLK | both HI | both HI | both HI | ! (both HI) | ! (both HI) | ! (both HI) | Tsens3 |
| ! (both HI) | ! (both HI) | ! (both HI) | both HI | both HI | both HI | PWM1 | ! (both HI) | ! (both HI) | ! (both HI) | both HI | both HI | both HI | Tsens4 |
| both HI | ! (both HI) | ! (both HI) | both HI | both HI | both HI | PWM2 | both HI | ! (both HI) | ! (both HI) | both HI | both HI | both HI | x |
| ! (both HI) | both HI | both HI | both HI | both HI | both HI | OL | ! (both HI) | both HI | both HI | both HI | both HI | both HI | x |
| both HI | both HI | both HI | both HI | both HI | both HI | OC | both HI | both HI | both HI | both HI | both HI | both HI | Vbandgap |

4.10 SPI - input data and Status registers

Table 19. SPI - input data and Status registers 0

| Bit | Input register 0 (write) | | | Status register 0 (read) | | |
|-----|---|---|--------|-----------------------------|--|--|
| | Name | Comment | | Name | Comment | |
| 23 | Enable bit | If Enable Bit is set the device will be switched in active mode. If Enable Bit is cleared the device go into standby mode and all bits are cleared. After power-on reset device starts in standby mode. | | Always 1 | A broken VCC-or SPI-connection of the L9953 can be detected by the microcontroller, because all 24 bits low or high is not a valid frame. | |
| 22 | Reset bit | If Reset Bit is set both status registers will be cleared after rising edge of CSN input. | | V _S overvoltage | In case of an overvoltage or undervoltage event the corresponding bit is set and the outputs are deactivated. If VS voltage recovers to normal operating conditions outputs are reactivated automatically (if Bit 20 of status register 0 is not set). | |
| 21 | OC recovery duty cycle | This bit defines in combination with the over-current recovery bit (Input Register 1) the duty cycle in over-current condition of an activated driver. | | V _S undervoltage | In case of a thermal shutdown all outputs are switched off. The microcontroller has to clear the TSD bit by setting the Reset Bit to reactivate the outputs. | |
| | 0: 12% 1: 25% | | | | | |
| 20 | Overvoltage/Undervoltage recovery disable | If this bit is set the microcontroller has to clear the status register after undervoltage/overvoltage event to enable the outputs. | | Thermal shutdown | In case of a thermal shutdown all outputs are switched off. The microcontroller has to clear the TSD bit by setting the Reset Bit to reactivate the outputs. | |
| 19 | | Depending on combination of bit 18 and 19 the current image (1/10.000) of the selected HS-output will be multiplexed to the CM output: | | Temperature warning | This TW bit is for information purpose only. It can be used for a thermal management by the microcontroller to avoid a thermal shutdown. | |
| 18 | Current monitor select bits | Bit 19 | Bit 18 | Output | Not ready bit | After switching the device from standby mode to active mode an internal timer is started to allow charge pump to settle before the outputs can be activated. This bit is cleared automatically after start up time has finished. Since this bit is controlled by internal clock it can be used for synchronizing testing events (e.g. measuring filter times). |
| | | 0 | 0 | OUT8 | | |
| | | 1 | 0 | OUT1 | | |
| | | 0 | 1 | OUT5 | | |
| | | 1 | 1 | OUT4 | | |

Table 19. SPI - input data and Status registers 0 (continued)

| Bit | Input register 0 (write) | | Status register 0 (read) | |
|-----|--------------------------|--|--------------------------|--|
| | Name | Comment | Name | Comment |
| 17 | OUT8 – HS on/off | <p>If a bit is set the selected output driver is switched on. If the corresponding PWM enable bit is set (Input Register 1) the driver is only activated if PWM1 (PWM2) input signal is high. The outputs of OUT1-OUT5 are half bridges. If the bits of HS- and LS-driver of the same half bridge are set, the internal logic prevents that both drivers of this output stage can be switched on simultaneously in order to avoid a high internal current from VS to GND. In test mode (CSN>9.5V) this bit combinations are used to multiplex internal signals to the DO-output.</p> <p>LS3 HS3 LS4 HS4 LS5 HS5 CM/PWM2 0 0 0 0 0 0 5µA Iref 1 1 0 0 0 0 Tsens1 0 0 1 1 0 0 Tsens2 1 1 1 1 0 0 Tsens3 0 0 0 0 1 1 Tsens4 1 1 1 1 1 1 Vbpg</p> | OUT8 – HS over-current | <p>In case of an over-current event the corresponding status bit is set and the output driver is disabled. If the over-current Recovery Enable bit is set (Input Register 1) the output will be automatically reactivated after a delay time resulting in a PWM modulated current with a programmable duty cycle (Bit 21).</p> <p>If the over-current recovery bit is not set the microcontroller has to clear the over-current bit (Reset Bit) to reactivate the output driver.</p> |
| 16 | x (don't care) | | 0 | |
| 15 | OUT7 – HS on/off | | OUT7 – HS over-current | |
| 14 | OUT6 – HS on/off | | OUT6 – HS over-current | |
| 13 | x (don't care) | | 0 | |
| 12 | x (don't care) | | 0 | |
| 11 | x (don't care) | | | |
| 10 | OUT5 – HS on/off | | OUT5 – HS over-current | |
| 9 | OUT5 – LS on/off | | OUT5 – LS over-current | |
| 8 | OUT4 – HS on/off | | OUT4 – HS over-current | |
| 7 | OUT4 – LS on/off | | OUT4 – LS over-current | |
| 6 | OUT3 – HS on/off | | OUT3 – HS over-current | |
| 5 | OUT3 – LS on/off | | OUT3 – LS over-current | |
| 4 | OUT2 – HS on/off | | OUT2 – HS over-current | |
| 3 | OUT2 – LS on/off | | OUT2 – LS over-current | |
| 2 | OUT1 – HS on/off | | OUT1 – HS over-current | |
| 1 | OUT1 – LS on/off | | OUT1 – LS over-current | |
| 0 | | 0 | No error bit | A logical NOR-combination of all bits 1 to 22 in both status registers. |

Table 20. SPI - input data and status registers 1

| Bit | Input register 1 (write) | | Status register 1 (read) | |
|-----|--------------------------|--|--------------------------|--|
| | Name | Comment | Name | Comment |
| 23 | Enable bit | If Enable bit is set the device will be switched in active mode. If Enable Bit is cleared device goes into standby mode and all bits are cleared. After power-on reset device starts in standby mode. | Always 1 | A broken VCC-or SPI-connection of the L9953 can be detected by the microcontroller, because all 24 bits low or high is not a valid frame. |
| 22 | OUT8 OC Recovery Enable | In case of an over-current event the over-current status bit (Status Register 0) is set and the output is switched off. If the over-current Recovery Enable bit is set the output will be automatically reactivated after a delay time resulting in a PWM modulated current with a programmable duty cycle (Bit 21 of Input Data Register 0). Depending on occurrence of Overturned Event and internal clock phase it is possible that one recovery cycle is executed even if this bit is set to zero. | VS overvoltage | In case of an overvoltage or under voltage event the corresponding bit is set and the outputs are deactivated. If Vs voltage recovers to normal operating conditions outputs are reactivated automatically. |
| 21 | 0 / 1 | | VS undervoltage | |
| 20 | OUT7 OC Recovery Enable | | Thermal shutdown | In case of a thermal shutdown all outputs are switched off. The microcontroller has to clear the TSD bit by setting the Reset Bit to reactivate the outputs. |
| 19 | OUT6 OC Recovery Enable | | Temperature warning | The TW bit can be used for thermal management by the microcontroller to avoid a thermal shutdown. The microcontroller has to clear the TW bit. |
| 18 | 0 / 1 | | Not ready bit | After switching the device from standby mode to active mode an internal timer is started to allow charge pump to settle before the outputs can be activated. This bit is only present during start up time Since this bit is controlled by internal clock it can be used for synchronizing testing events(e.g. measuring filter times). |

Table 20. SPI - input data and status registers 1 (continued)

| Bit | Input register 1 (write) | | Status register 1 (read) | | |
|-----|--------------------------|---|---|---|---|
| | Name | Comment | Name | Comment | |
| 17 | | After 50ms the bit can be cleared. If over-current condition still exists, a wrong load can be assumed. | OUT8 – HS open load | The open load detection monitors the load current in each activated output stage. If the load current is below the open load detection threshold for at least 1 ms (t_{dOL}) the corresponding open load bit is set. Due to mechanical/electrical inertia of typical loads a short activation of the outputs (e.g. 3ms) can be used to test the open load status without changing the mechanical/electrical state of the loads. | |
| 16 | OUT5 OC Recovery Enable | | 0 | | |
| 15 | OUT4 OC Recovery Enable | | OUT7 – HS open load | | |
| 14 | OUT3 OC Recovery Enable | | OUT6 – HS open load | | |
| 13 | OUT2 OC Recovery Enable | | 0 | | |
| 12 | OUT1 OC Recovery Enable | | 0 | | |
| 11 | OUT8 PWM1 Enable | | If the PWM1/2 Enable Bit is set and the output is enabled (Input Register 0) the output is switched on if PWM1/2 input is high and switched off if PWM1/2 input is low. OUT7 is controlled by PWM2 input. All other outputs are controlled by PWM1 input. For test mode rise CSN>9.5 V. | | 0 |
| 10 | 0 / 1 | | | | OUT5 – HS open load |
| 9 | OUT7 PWM2 Enable | OUT5 – LS open load | | | |
| 8 | OUT6 PWM1 Enable | OUT4 – HS open load | | | |
| 7 | 0 / 1 | OUT4 – LS open load | | | |
| 6 | 0 / 1 | OUT3 – HS open load | | | |
| 5 | OUT5 PWM1 Enable | OUT3 – LS open load | | | |
| 4 | OUT4 PWM1 Enable | OUT2 –HS open load | | | |
| 3 | OUT3 PWM1 Enable | OUT2– LS open load | | | |
| 2 | OUT2 PWM1 Enable | OUT1 – HS open load | | | |
| 1 | OUT1 PWM1 Enable | OUT1 – LS open load | | | |
| 0 | | 1 | No Error bit | | A logical NOR-combination of all bits 1 to 22 in both status registers. |

5 Packages thermal data

Figure 10. Packages thermal data

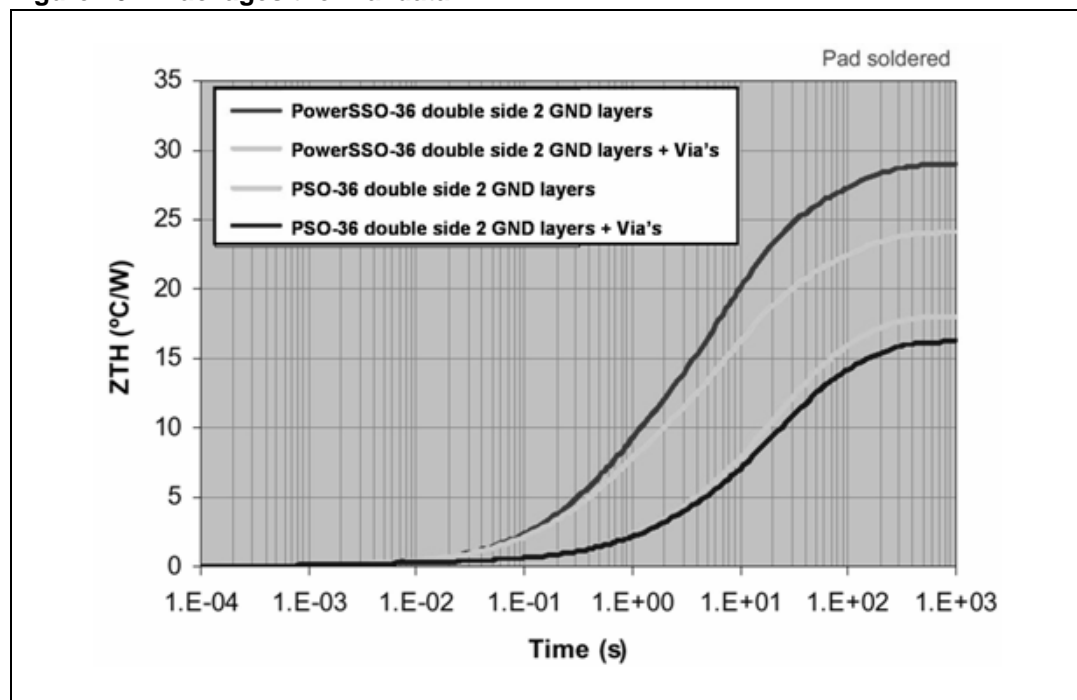

6 Package and packing information

6.1 ECOPACK[®] packages

In order to meet environmental requirements, ST offers these devices in different grades of ECOPACK[®] packages, depending on their level of environmental compliance. ECOPACK[®] specifications, grade definitions and product status are available at: www.st.com.

ECOPACK[®] is an ST trademark.

6.2 PowerSO-36[™] package information

Figure 11. PowerSO-36[™] package dimensions

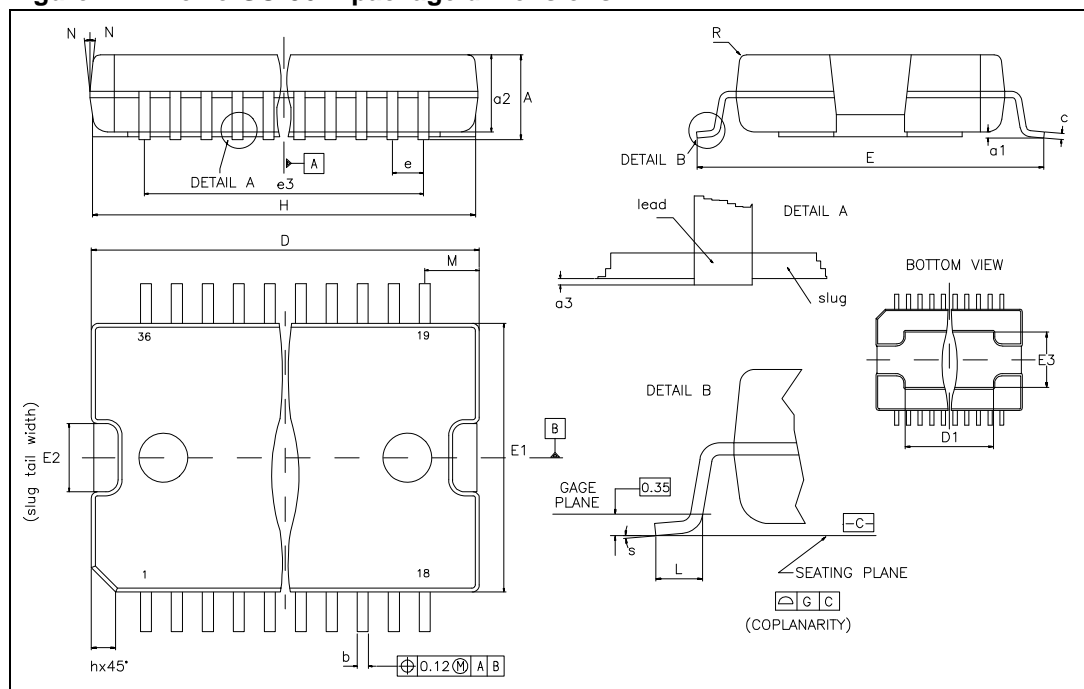

Table 21. PowerSO-36™ mechanical data

| Symbol | Millimeters | | |
|--------|-------------|-------|--------|
| | Min. | Typ. | Max. |
| A | | | 3.60 |
| a1 | 0.10 | | 0.30 |
| a2 | | | 3.30 |
| a3 | 0 | | 0.10 |
| b | 0.22 | | 0.38 |
| c | 0.23 | | 0.32 |
| D * | 15.80 | | 16.00 |
| D1 | 9.40 | | 9.80 |
| E | 13.90 | | 14.5 |
| E1 * | 10.90 | | 11.10 |
| E2 | | | 2.90 |
| E3 | 5.80 | | 6.20 |
| e | | 0.65 | |
| e3 | | 11.05 | |
| G | 0 | | 0.10 |
| H | 15.50 | | 15.90 |
| h | | | 1.10 |
| L | 0.8 | | 1.10 |
| M | | | |
| N | | | 10 deg |
| R | | | |
| s | | | 8 deg |

6.3 PowerSSO-36™ package information

Figure 12. PowerSSO-36™ package dimensions

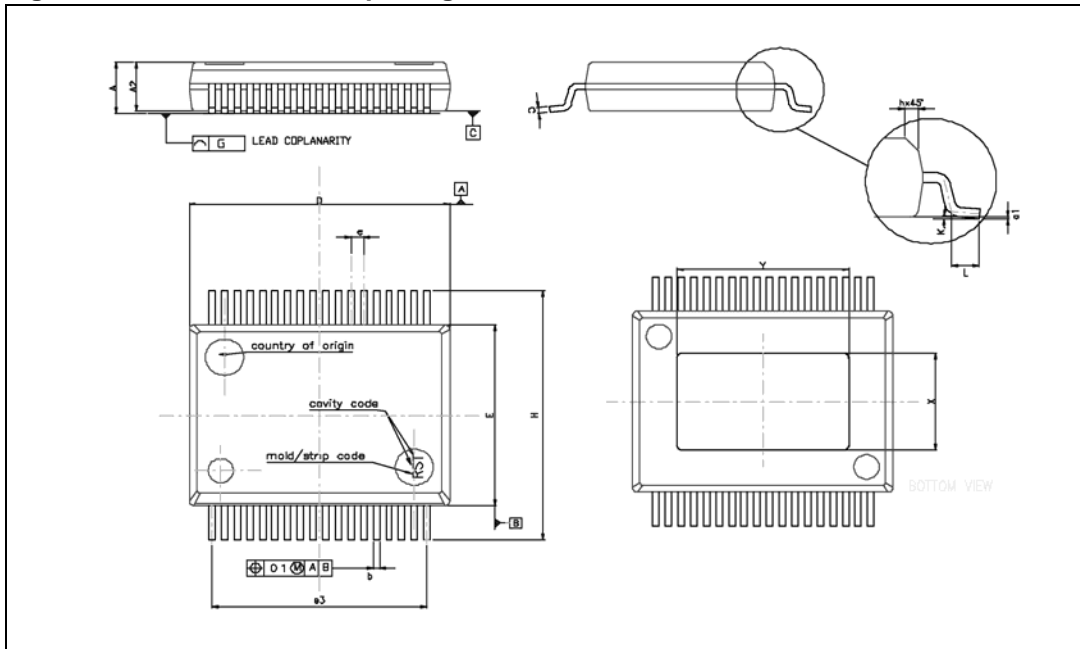

Table 22. PowerSSO-36™ mechanical data

| Symbol | Millimeters | | |
|--------|-------------|------|--------|
| | Min. | Typ. | Max. |
| A | - | - | 2.45 |
| A2 | 2.15 | - | 2.35 |
| a1 | 0 | - | 0.1 |
| b | 0.18 | - | 0.36 |
| c | 0.23 | - | 0.32 |
| D * | 10.10 | - | 10.50 |
| E * | 7.4 | - | 7.6 |
| e | - | 0.5 | - |
| e3 | - | 8.5 | - |
| F | - | 2.3 | - |
| G | - | - | 0.1 |
| G1 | - | - | 0.06 |
| H | 10.1 | - | 10.5 |
| h | - | - | 0.4 |
| k | 0° | - | 8° |
| L | 0.55 | - | 0.85 |
| N | - | - | 10 deg |

Table 22. PowerSSO-36™ mechanical data (continued)

| Symbol | Millimeters | | |
|--------|-------------|------|------|
| | Min. | Typ. | Max. |
| X | 4.3 | - | 5.2 |
| Y | 6.9 | - | 7.5 |

6.4 PowerSO-36™ packing information

Figure 13. PowerSO-36™ tube shipment (no suffix)

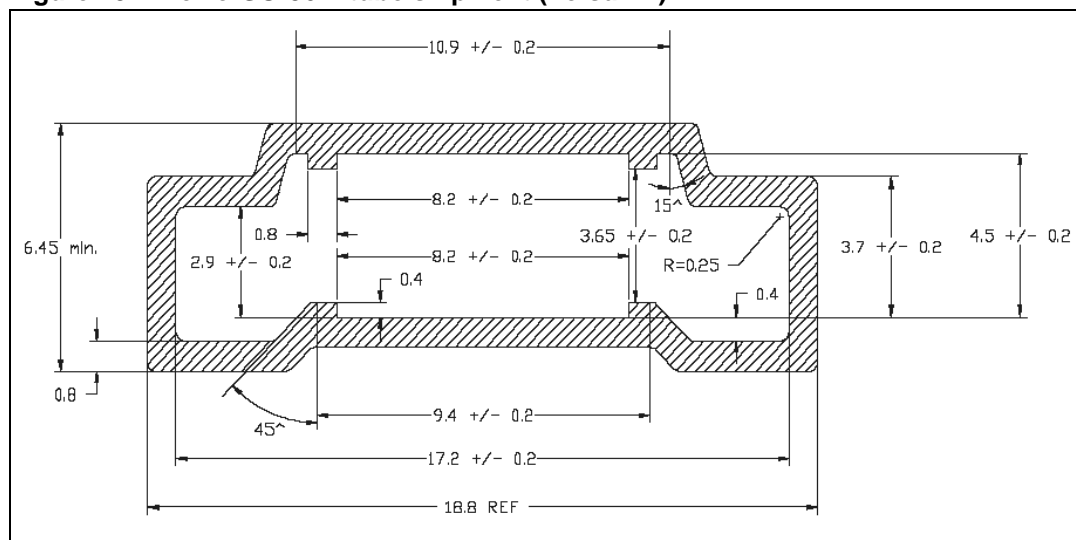
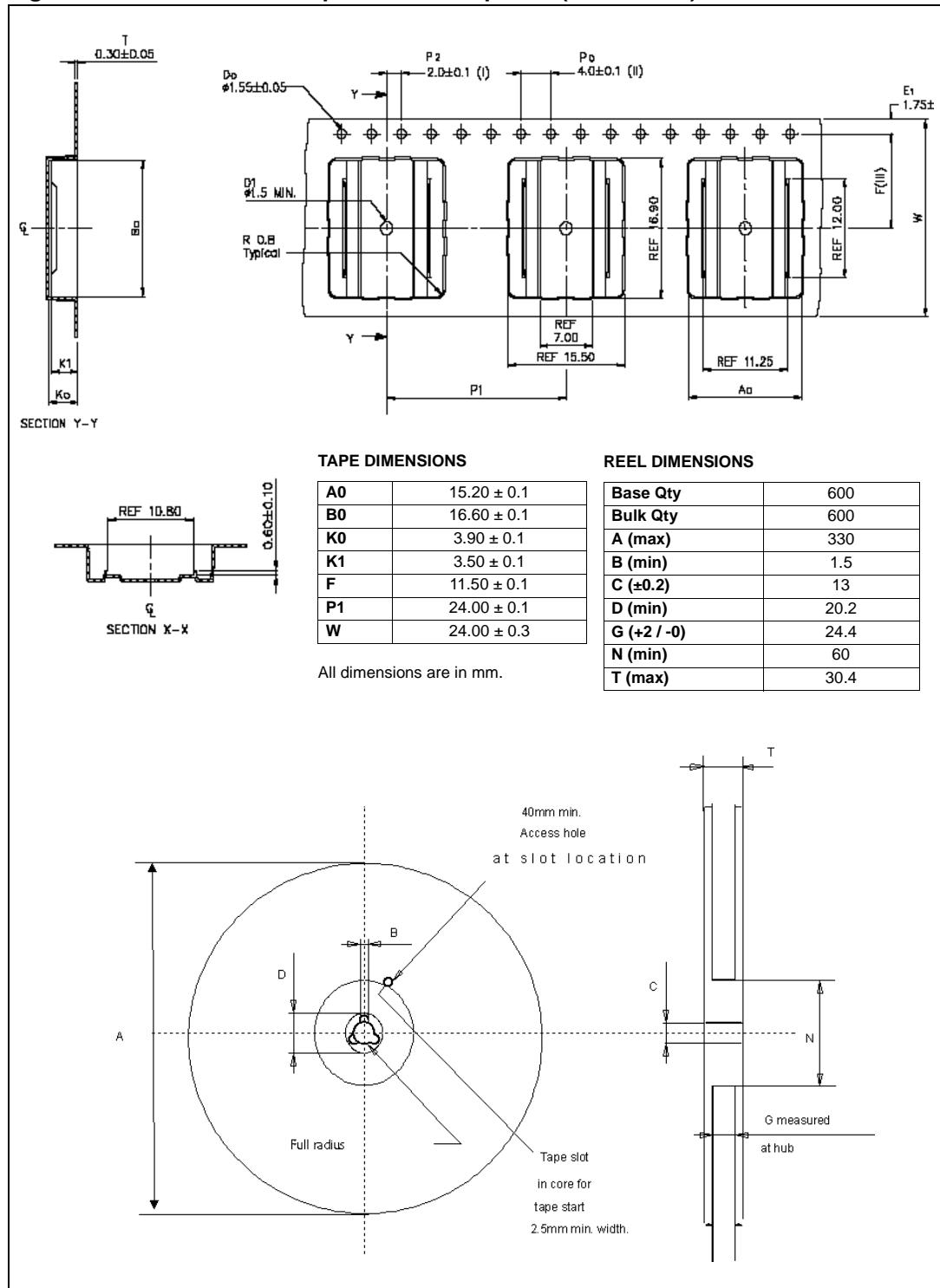

Figure 14. PowerSO-36™ tape and reel shipment (suffix “TR”)



6.5 PowerSSO-36™ packing information

Figure 15. PowerSSO-36™ tube shipment (no suffix)

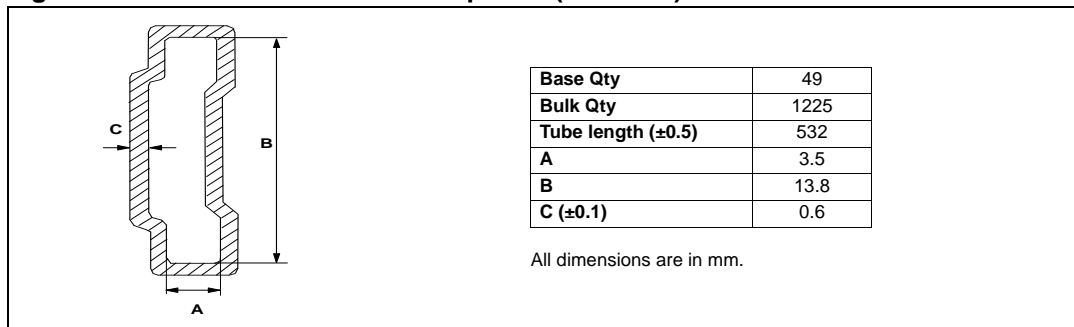
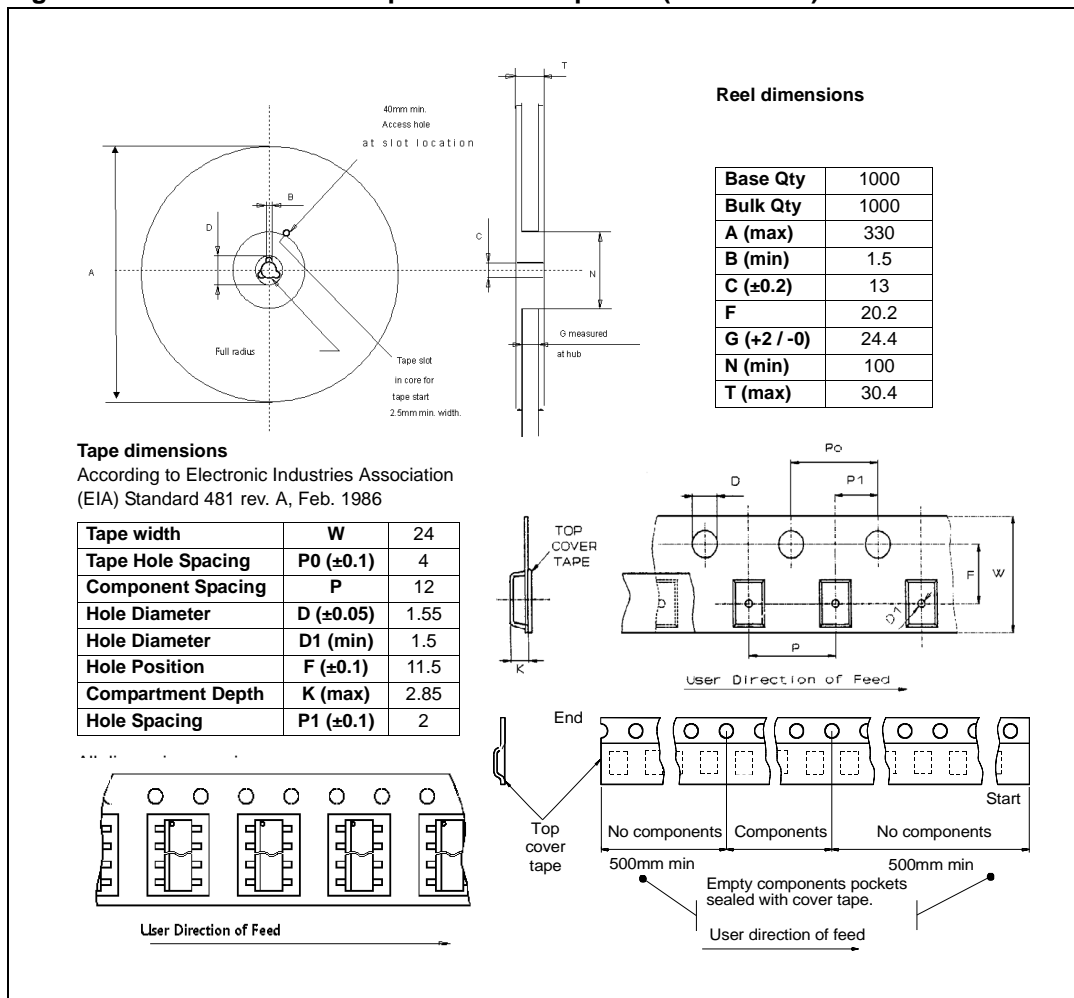

Figure 16. PowerSSO-36™ tape and reel shipment (suffix “TR”)



7 Revision history

Table 23. Document revision history

| Date | Revision | Description of changes |
|-------------|----------|---|
| 23-Jan-2008 | 1 | Initial release. |
| 24-Jun-2009 | 2 | <i>Table 22: PowerSSO-36™ mechanical data:</i> <ul style="list-style-type: none">– Deleted A (min) value– Changed A (max) value from 2.47 to 2.45– Changed A2 (max) value from 2.40 to 2.35– Changed a1 (max) value from 0.075 to 0.1– Added F and k rows |
| 14-May-2010 | 3 | <i>Table 22: PowerSSO-36™ mechanical data:</i> <ul style="list-style-type: none">– Changed X: minimum value from 4.1 to 4.3 and maximum value from 4.7 to 5.2– Changed Y: minimum value from 6.5 to 6.9 and maximum value from 7.1 to 7.5 |
| 22-Sep-2013 | 4 | Updated Disclaimer. |

Please Read Carefully:

Information in this document is provided solely in connection with ST products. STMicroelectronics NV and its subsidiaries ("ST") reserve the right to make changes, corrections, modifications or improvements, to this document, and the products and services described herein at any time, without notice.

All ST products are sold pursuant to ST's terms and conditions of sale.

Purchasers are solely responsible for the choice, selection and use of the ST products and services described herein, and ST assumes no liability whatsoever relating to the choice, selection or use of the ST products and services described herein.

No license, express or implied, by estoppel or otherwise, to any intellectual property rights is granted under this document. If any part of this document refers to any third party products or services it shall not be deemed a license grant by ST for the use of such third party products or services, or any intellectual property contained therein or considered as a warranty covering the use in any manner whatsoever of such third party products or services or any intellectual property contained therein.

UNLESS OTHERWISE SET FORTH IN ST'S TERMS AND CONDITIONS OF SALE ST DISCLAIMS ANY EXPRESS OR IMPLIED WARRANTY WITH RESPECT TO THE USE AND/OR SALE OF ST PRODUCTS INCLUDING WITHOUT LIMITATION IMPLIED WARRANTIES OF MERCHANTABILITY, FITNESS FOR A PARTICULAR PURPOSE (AND THEIR EQUIVALENTS UNDER THE LAWS OF ANY JURISDICTION), OR INFRINGEMENT OF ANY PATENT, COPYRIGHT OR OTHER INTELLECTUAL PROPERTY RIGHT.

ST PRODUCTS ARE NOT DESIGNED OR AUTHORIZED FOR USE IN: (A) SAFETY CRITICAL APPLICATIONS SUCH AS LIFE SUPPORTING, ACTIVE IMPLANTED DEVICES OR SYSTEMS WITH PRODUCT FUNCTIONAL SAFETY REQUIREMENTS; (B) AERONAUTIC APPLICATIONS; (C) AUTOMOTIVE APPLICATIONS OR ENVIRONMENTS, AND/OR (D) AEROSPACE APPLICATIONS OR ENVIRONMENTS. WHERE ST PRODUCTS ARE NOT DESIGNED FOR SUCH USE, THE PURCHASER SHALL USE PRODUCTS AT PURCHASER'S SOLE RISK, EVEN IF ST HAS BEEN INFORMED IN WRITING OF SUCH USAGE, UNLESS A PRODUCT IS EXPRESSLY DESIGNATED BY ST AS BEING INTENDED FOR "AUTOMOTIVE, AUTOMOTIVE SAFETY OR MEDICAL" INDUSTRY DOMAINS ACCORDING TO ST PRODUCT DESIGN SPECIFICATIONS. PRODUCTS FORMALLY ESCC, QML OR JAN QUALIFIED ARE DEEMED SUITABLE FOR USE IN AEROSPACE BY THE CORRESPONDING GOVERNMENTAL AGENCY.

Resale of ST products with provisions different from the statements and/or technical features set forth in this document shall immediately void any warranty granted by ST for the ST product or service described herein and shall not create or extend in any manner whatsoever, any liability of ST.

ST and the ST logo are trademarks or registered trademarks of ST in various countries.

Information in this document supersedes and replaces all information previously supplied.

The ST logo is a registered trademark of STMicroelectronics. All other names are the property of their respective owners.

© 2013 STMicroelectronics - All rights reserved

STMicroelectronics group of companies

Australia - Belgium - Brazil - Canada - China - Czech Republic - Finland - France - Germany - Hong Kong - India - Israel - Italy - Japan - Malaysia - Malta - Morocco - Philippines - Singapore - Spain - Sweden - Switzerland - United Kingdom - United States of America



www.st.com

Looking for pricing, stock, or lifecycle information?

Click below to explore more details on WIN SOURCE:

-  [View L9953XPTR on WIN SOURCE](#)
-  [STMicroelectronics](#) Information

Optimize Your Supply Chain with WIN SOURCE Solutions

-  Global Sourcing Solution
-  Obsolete Management
-  Cost Control Management
-  Shortage Management
-  Alternative Solution
-  Excess Inventory Management