



THE DATASHEET OF L9930PD



DUAL FULL BRIDGE

- $R_{DS\ ON} = 2\Omega$
- INTERNAL CLAMPING VOLTAGE = 32V
- INTERNAL FREE WHEELING DIODES
- PARALLEL DRIVE CAPABILITY
- RESISTIVE OR INDUCTIVE LOAD

PROTECTION:

- TEMPERATURE PROTECTION
- SHORT-CIRCUIT PROTECTION (V_{bat} , LOAD, GND)

DETECTION:

- SHORTED LOAD
- OPEN LOAD
- OVERTEMPERATURE

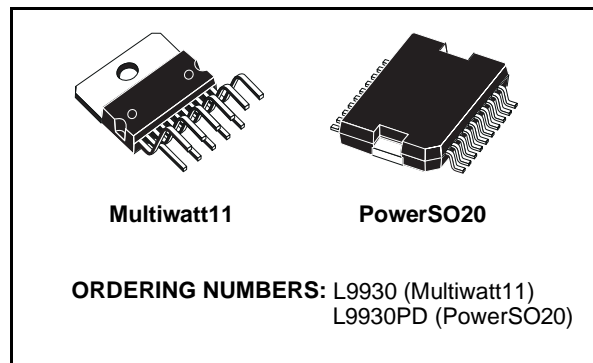

DESCRIPTION

The L9930 is a dual full-bridge. The output stages are Power Mos switches.

BLOCK DIAGRAM

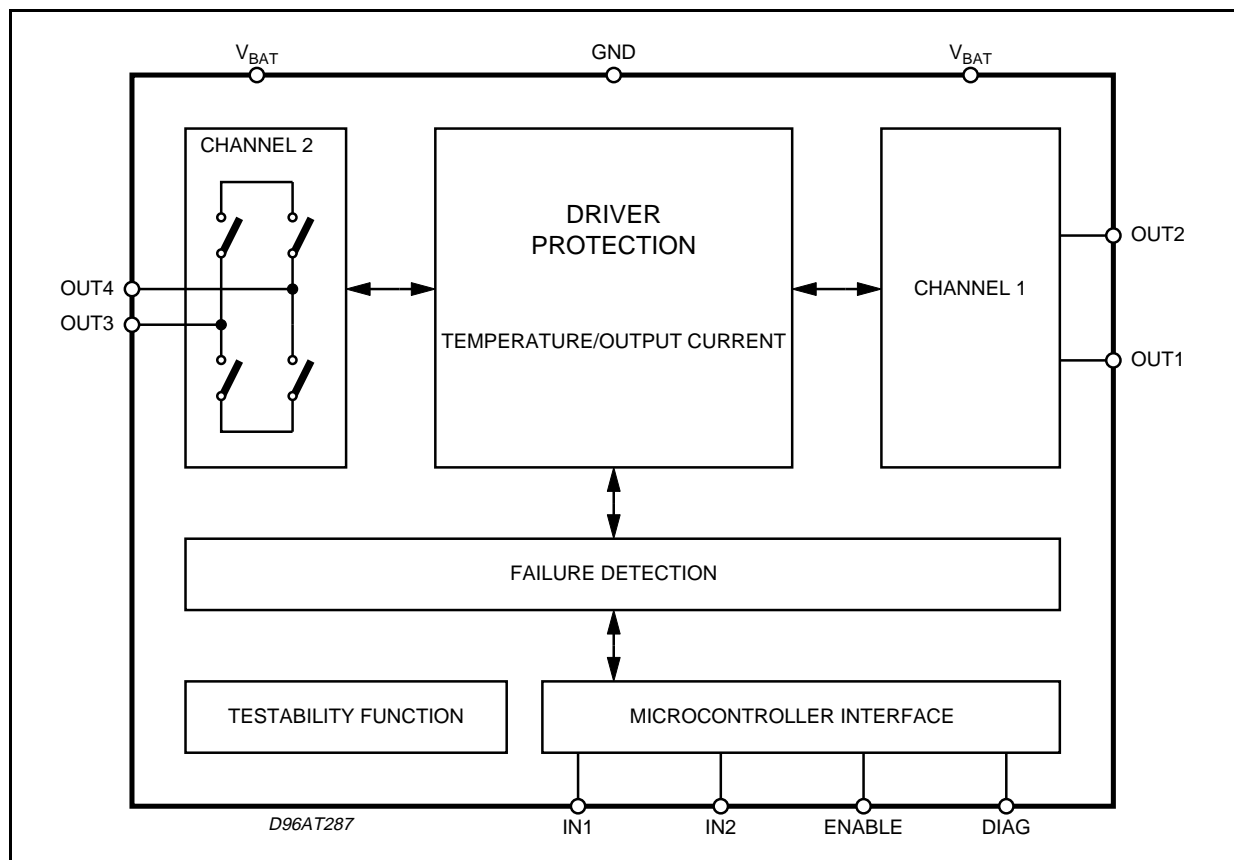

ABSOLUTE MAXIMUM RATINGS

Symbol	Parameter	Value	Unit
E	Clamped Energy at the Switching off	6 (max)	mJ
V _{out DC}	Continuous Output Voltage	24 (max)	V
V _{out tr}	Transient Output Voltage	32 (max)	V
V _{bat DC}	Continuous Battery Voltage	8 to 24	V
V _{bat tr}	Transient Battery Voltage	45 (max)	V
I _{out}	Reverse Output Current	- 2 (max)	A
f _{in}	Input Frequency	500 (max)	Hz
V _{in}	Input Voltage	- 0.3 to +7	V
V _{diag}	Diagnostic Voltage	- 0.3 to +7	V
T _s	Storage Temperature	- 55 to 150	°C
T _j	Operating Junction Temperature	- 40 to 150	°C
V _{ESD}	V _{ESD} (Note MIL STD 883C)	3000	V

PIN CONNECTION

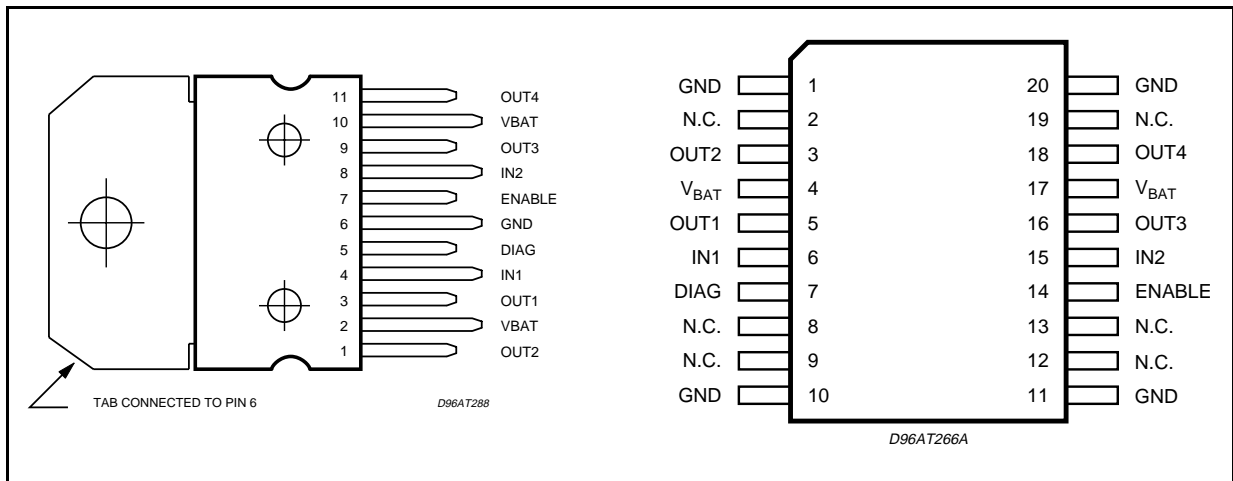

PIN FUNCTIONS

MW11	PowerSO20	Name	Function
1	3	OUT 2	Output Channel 1
2	4	V _{BAT}	Power Supply
3	5	OUT 1	Output Channel 1
4	6	IN 1	Input Channel 1
5	7	DIAG	Diagnostic Output Common for the 2 Channels
6	1, 10, 11, 20	GND	Ground
7	14	ENABLE	Enable
8	15	IN 2	Input Channel 2
9	16	OUT 3	Output Channel 2
10	17	V _{BAT}	Power Supply
11	18	OUT 4	Output Channel 2
	2, 8, 9, 12, 13, 19	NC	Not Connected

H - BRIDGE CONFIGURATION

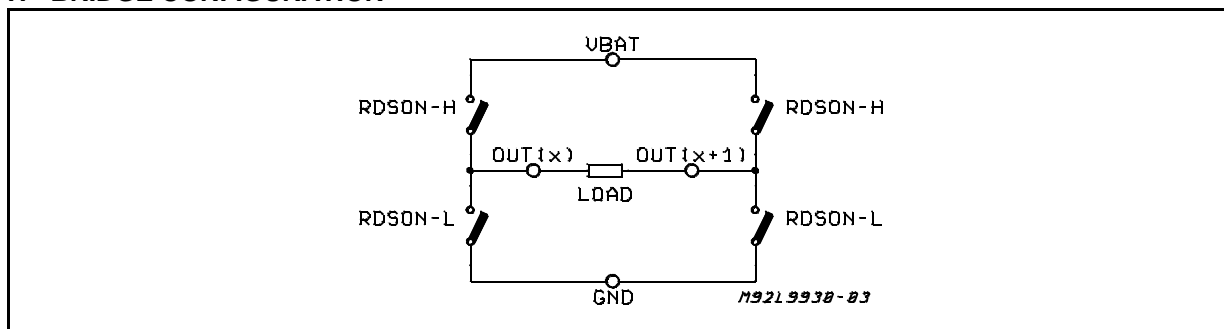

THERMAL DATA

Symbol	Parameter	Value	Unit
$R_{th\ j-case}$	Thermal Resistance Junction to Case	max.	$^{\circ}C/W$
$R_{th\ j-amb}$	Thermal resistance Junction to Ambient	max.	$^{\circ}C/W$

ELECTRICAL CHARACTERISTICS ($V_{bat} = 8$ to $18V$ $t_J = -40$ to $+150^{\circ}C$, unless otherwise specified.)

Symbol	Parameter	Test Condition	Min.	Typ.	Max.	Unit
R_{DSon-H}	ON Resistance	$I_{out} = 0.5A$		2	4.3	Ω
R_{DSon-L}	ON Resistance	$I_{out} = 0.5A$		2	4.3	Ω
V_{OCL}	Clamping Voltage	$I_{out} = 0.1A$		32		V
V_F	Clamp Diode Forward Voltage	$I_{out} = 0.5A$		1.3		V
T_R	Output Voltage Rise Time	V_{out} ; 0.1 to 0.9 V_{out} (see fig. 1) NOT LOADED		50	100	μs
T_F	Output Voltage Fall Time	V_{out} ; 0.9 to 0.1 V_{out} (see fig. 1) NOT LOADED		50	100	μs
T_{DR}	Input to Output Rising edge Delay	0.5 V_{IN} to 0.1 V_{out} (see fig. 1) NOT LOADED			50	μs
T_{DF}	Input to Output Falling Edge Delay	0.5 V_{IN} to 0.9 V_{out} (see fig. 1) NOT LOADED			50	μs

OUTPUT PROTECTIONS CHARACTERISTICS

I_{SC}	Short Circuit Typical Application (see fig 2)	$T_{amb} = -40^{\circ}C$	0.45		2.6	A
		$T_{amb} = 25^{\circ}C$	0.38		2.6	A
		$T_{amb} = 125^{\circ}C$	0.28		2.6	A
I_{SC}	Short Circuit Typical Application with Shottky Diodes (see fig 3)		0.8		2.6	A
T_{SD}	Temperature		160			$^{\circ}C$
T_{HYST}	Temperature Hysteresis			20		$^{\circ}C$

These protections switch off the full bridge.

OUTPUT DETECTIONS CHARACTERISTICS

R_{OPL-L}	Open-load Threshold Resistor	80			Ω
R_{OPL-H}		100			Ω

SUPPLY CHARACTERISTICS

I_{QHI}	Supply Current	$R_{LOAD1} = R_{LOAD2} = \infty$ $V_{BAT} = 14V$, $IN1 = IN2 = ENABLE = 5V$			15	mA
I_{QLO}		$R_{load1} = R_{load2} = 50\Omega$ $V_{BAT} = 12V$, $ENABLE = 0V$ $IN1 = IN2 = 0V$			0.5	mA

ELECTRICAL CHARACTERISTICS

INPUTS CHARACTERISTICS (normal and standby mode)

Symbol	Parameter	Test Condition	Min.	Typ.	Max.	Unit
V_{IH}	High Threshold				4	V
V_{IL}	Low Threshold		1			V
I_{NH1}	Input Current 1	$V_{IN} = 4V$			200	μA
I_{NLO}	Input Current 2	$V_{IN} = 1V$			50	μA

DIAGNOSTIC CHARACTERISTICS

V_{DIAGL}	Low Level Voltage	$I_{DIAG} = 2mA$		0.6	0.8	V
I_{DIAGH}	Leakage Current	$V_{DIAG} = 5.25V$		5	10	μA

INITIALIZATION CHARACTERISTICS

T_{INIT}	Initialization Timing	$V_{BAT} = 12V$	10			μs
T_{STUP}	Start-Up Timing	$V_{BAT} = 12V$	1			ms
T_{RESET}	Reset		10			μs

FILTER CHARACTERISTICS

T_{FILTER}			64	112	170	μs
T_{DIAG}			4	6	10	μs
T_{SYNC}			4	6	10	μs

TRUE TABLE

ENAB	IN1	IN2	OUT1	OUT2	OUT3	OUT4	MODE	DIAG
0	0	0	HZ	HZ	HZ	HZ	STANDBY	?
0	0	1	HZ	HZ	HZ	HZ	NORMAL	?
0	1	0	HZ	HZ	HZ	HZ	NORMAL	?
0	1	1	HZ	HZ	HZ	HZ	NORMAL	?
1	0	0	HSD	LSD	HSD	LSD	NORMAL	VALID
1	0	1	HSD	LSD	LSD	HSD	NORMAL	VALID
1	1	0	LSD	HSD	HSD	LSD	NORMAL	VALID
1	1	1	LSD	HSD	LSD	HSD	NORMAL	VALID

Figure 1:

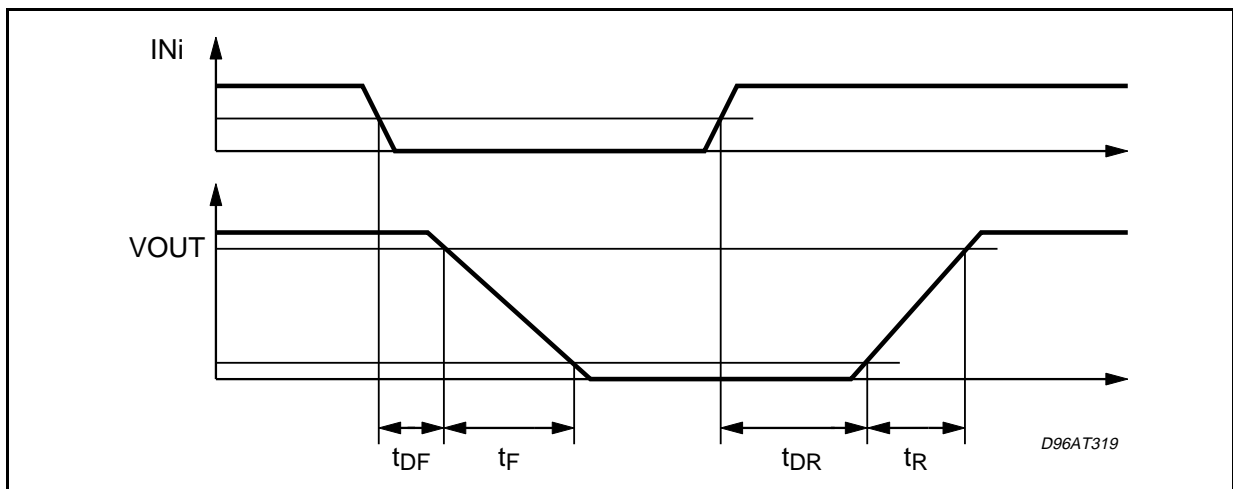

Figure 2: Typical Application

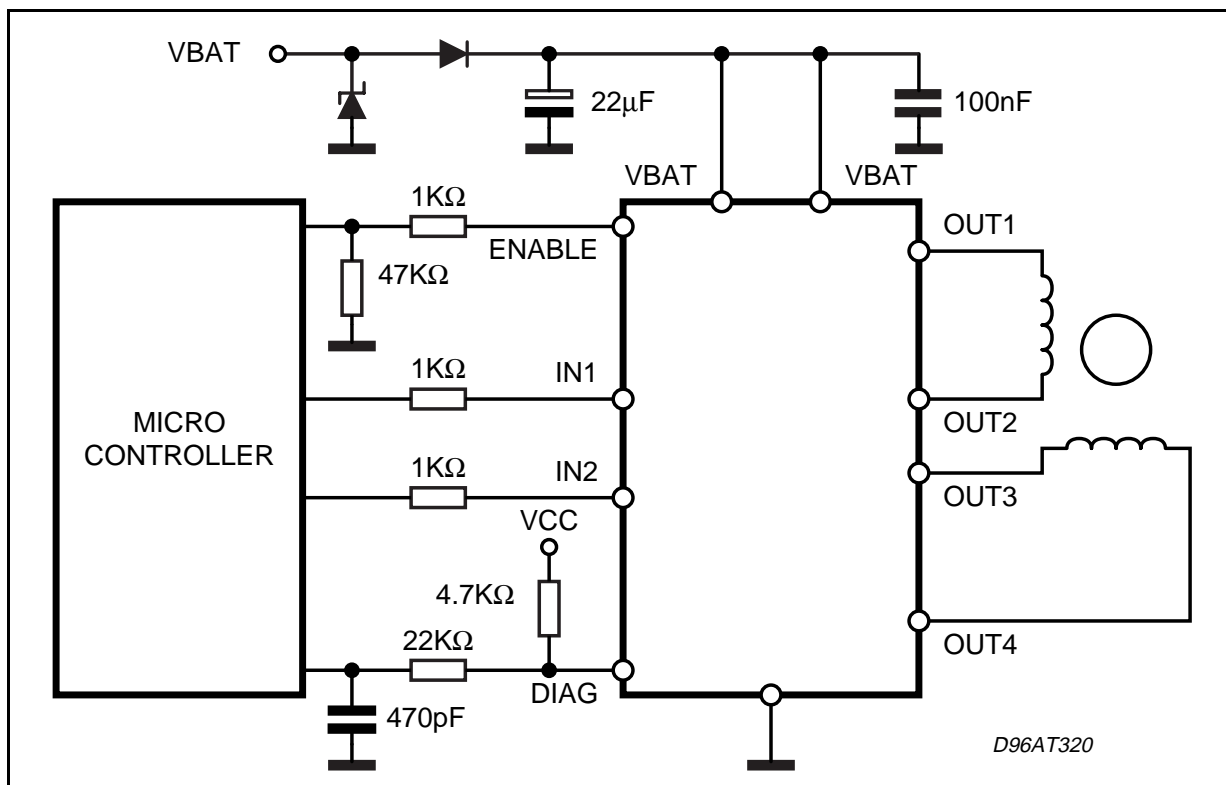

Figure 3: Typical Application with Schottky Diodes

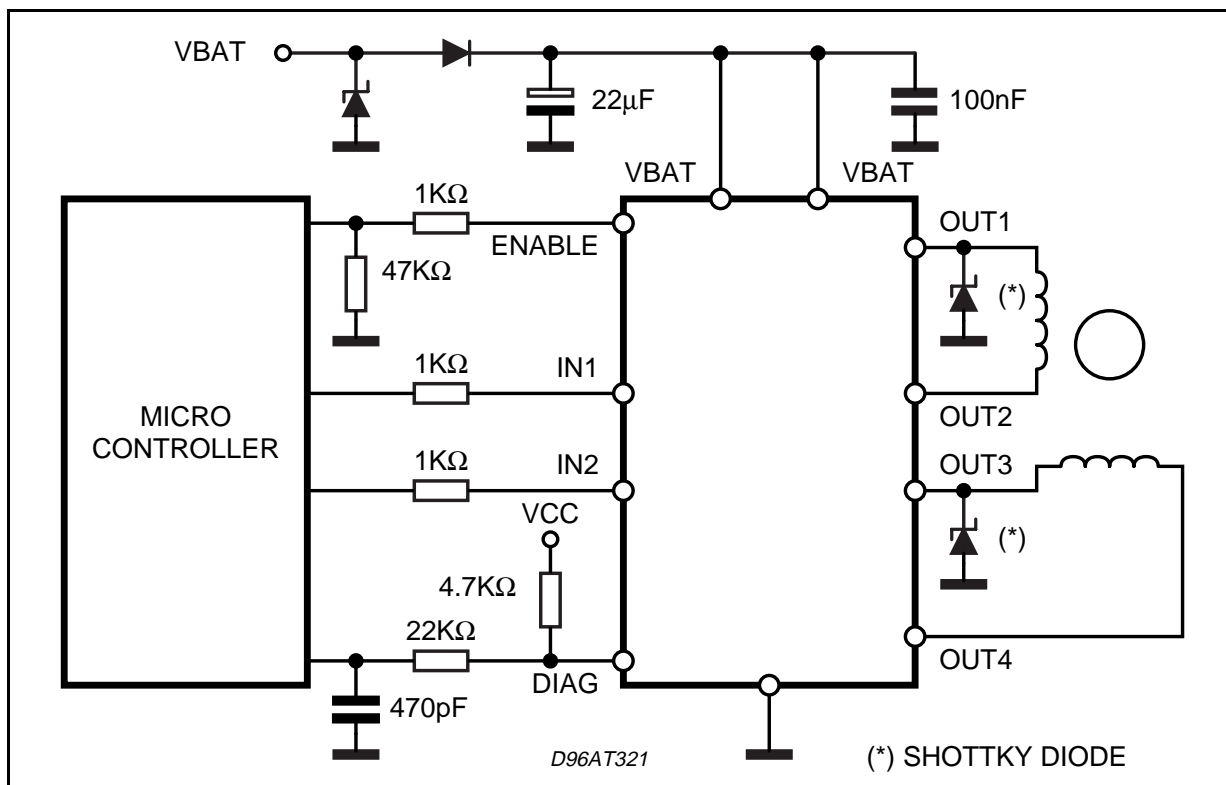

Figure 4: Initialization.

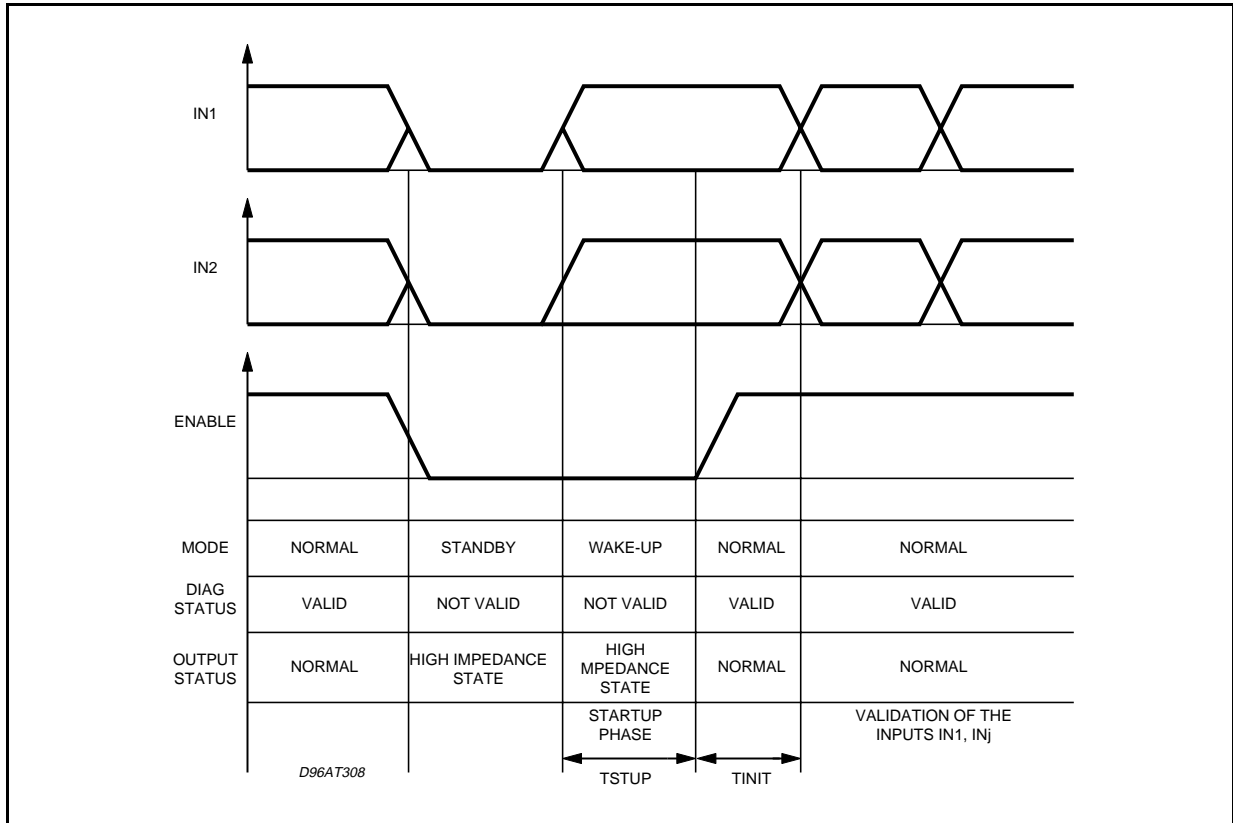

Figure 5: Normal Condition.

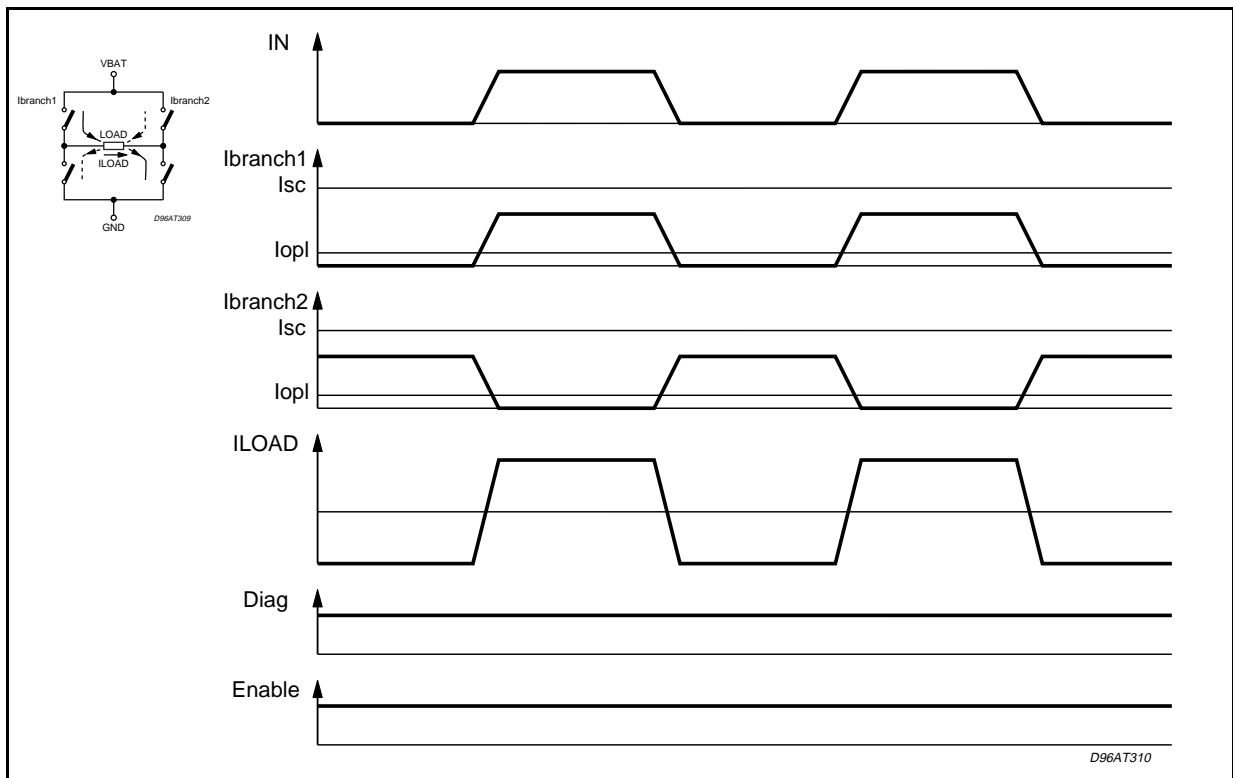

Figure 6: Short-circuit Condition.

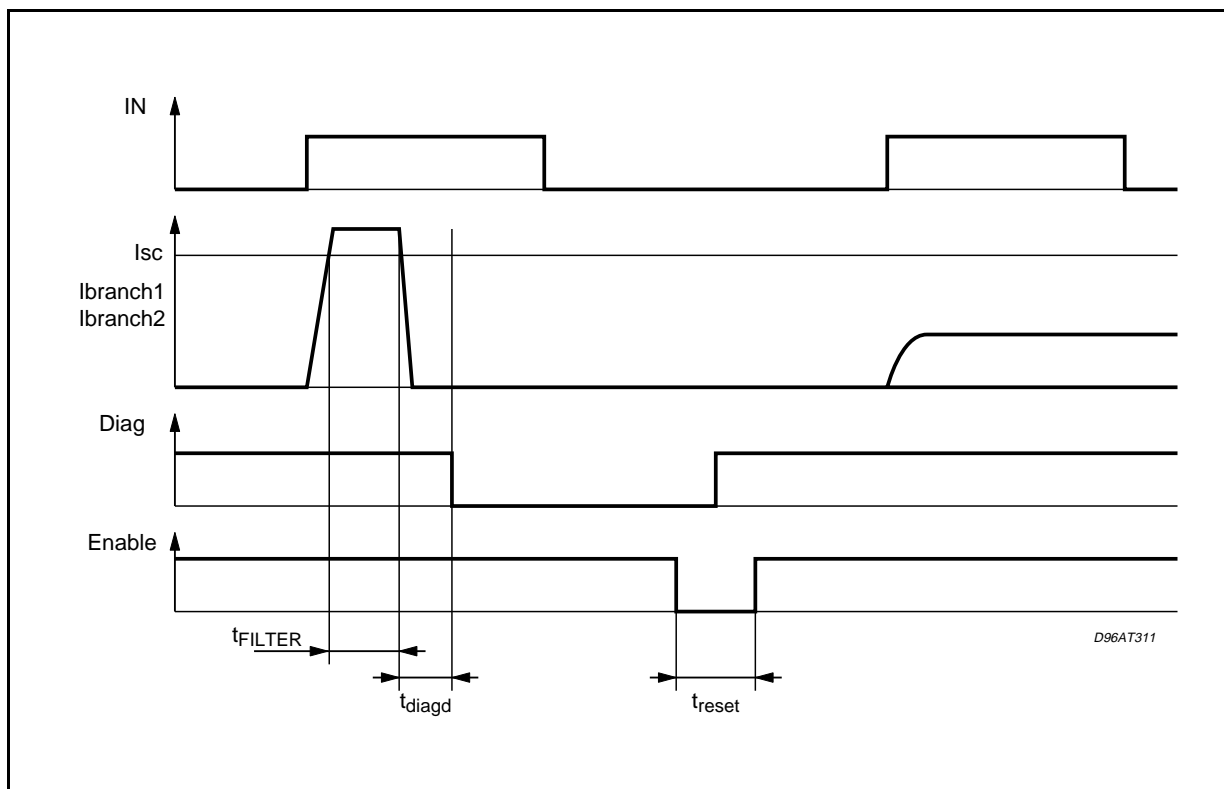

Figure 7: short circuit condition: no detection (NOT TESTED)

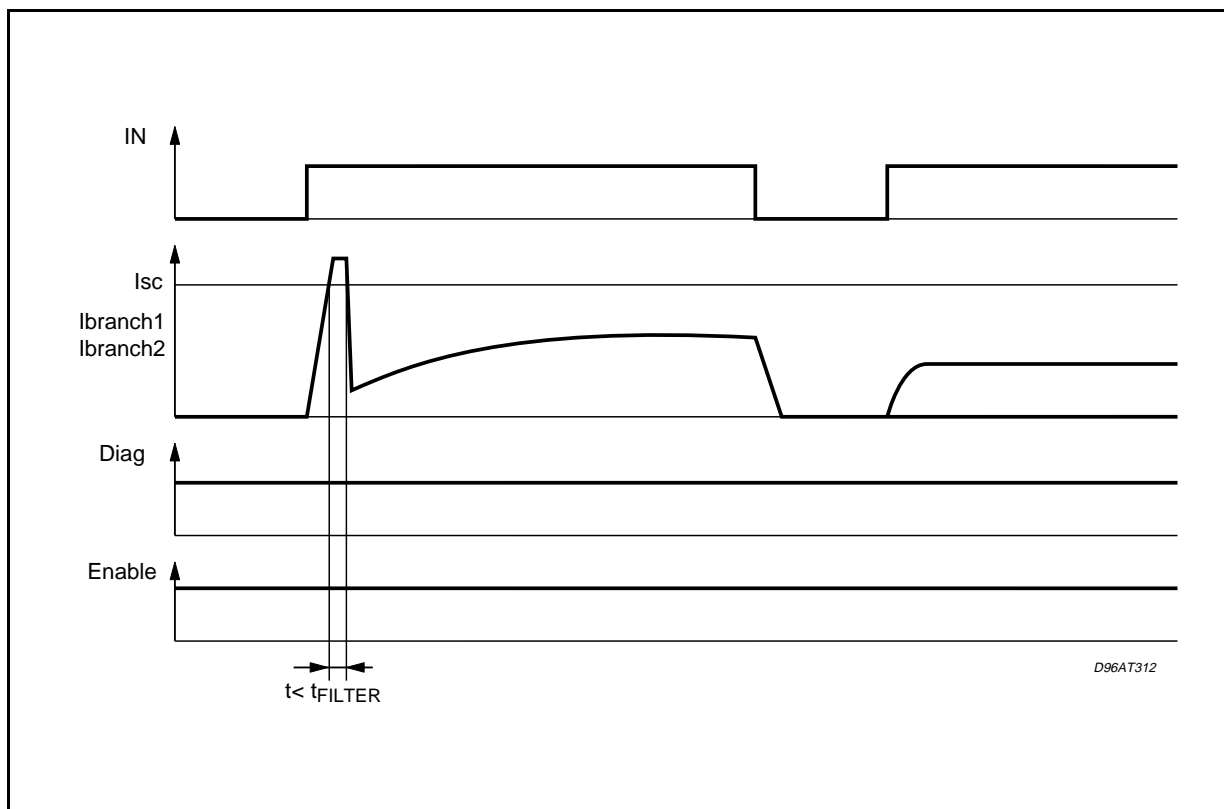

Figure 8: Open Load Condition 1: Detection

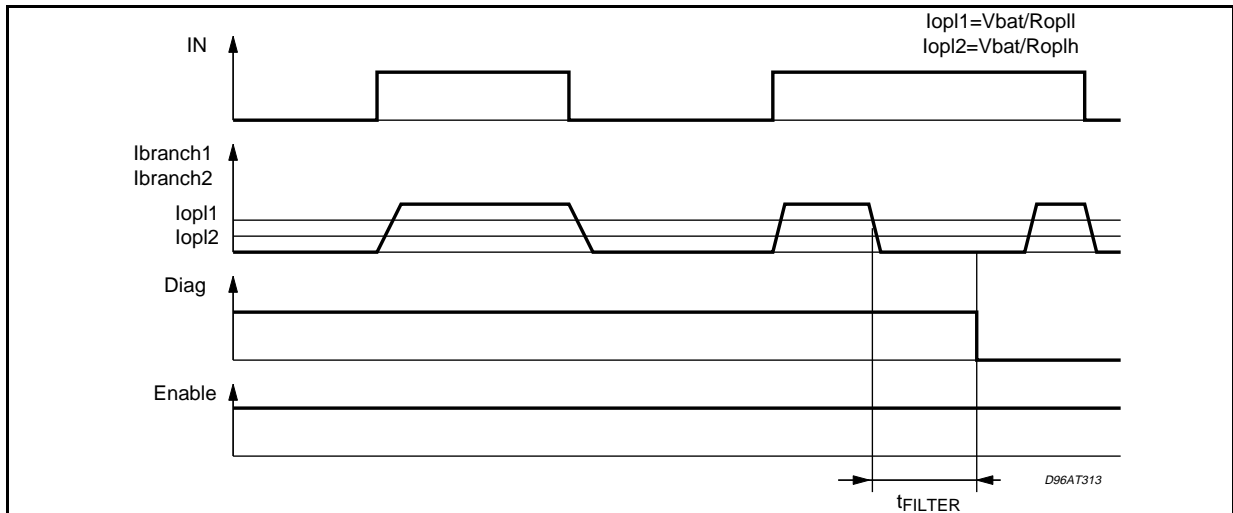

Figure 9: Open Load Condition 1: No Detection (NOT TESTED)

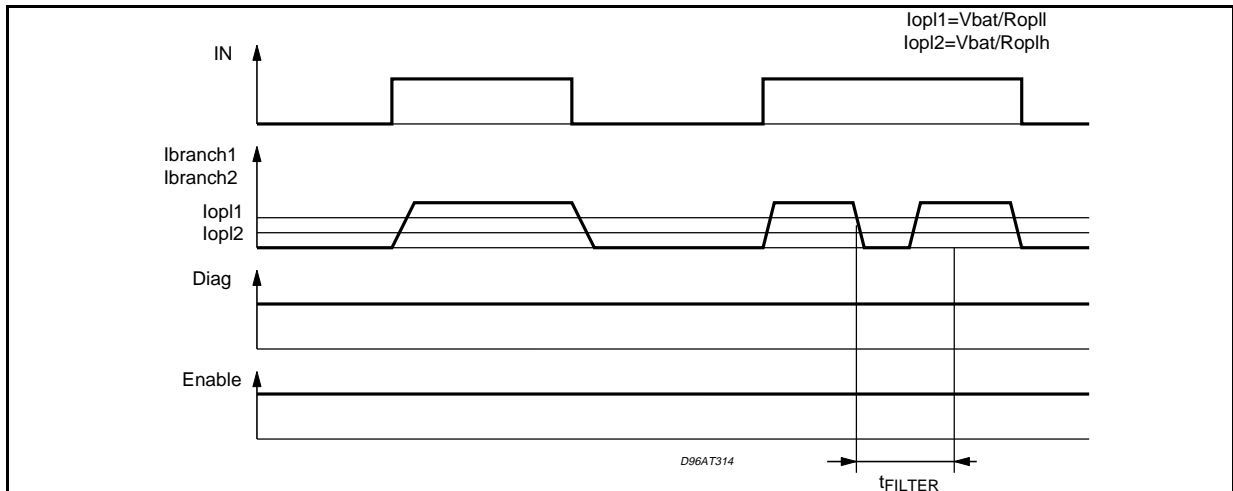

Figure 10: Open Load Condition 2: No Current after (ENABLE)



Figure 11: Open Load Condition 3

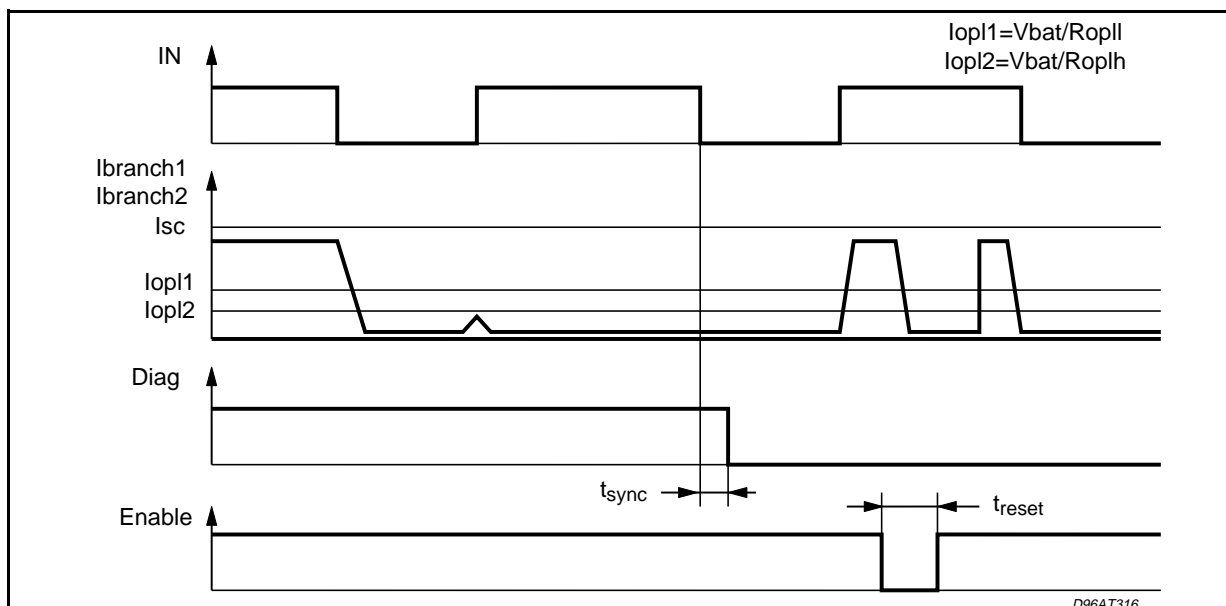

Figure 12: Open Load Condition 4: No Detection

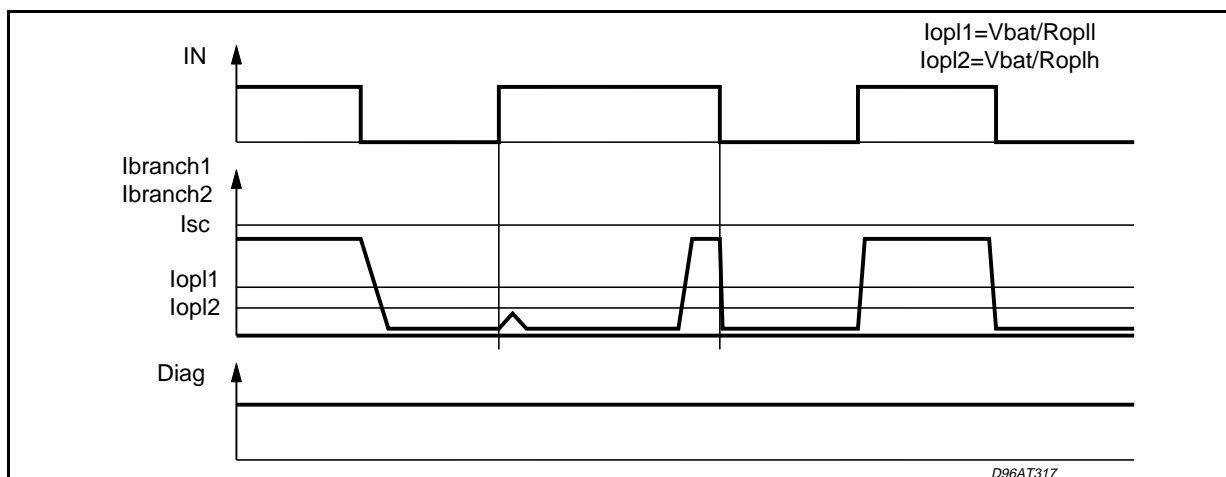
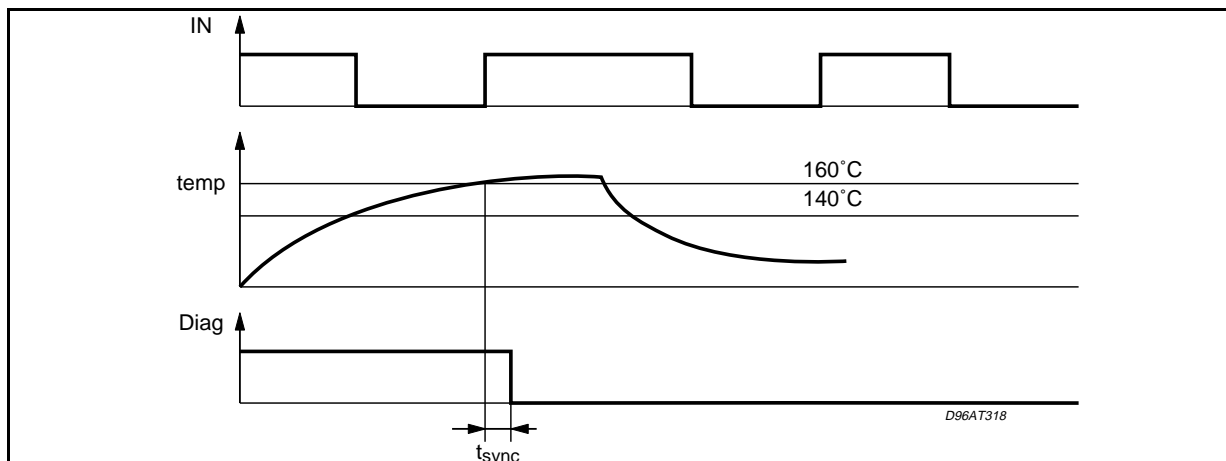
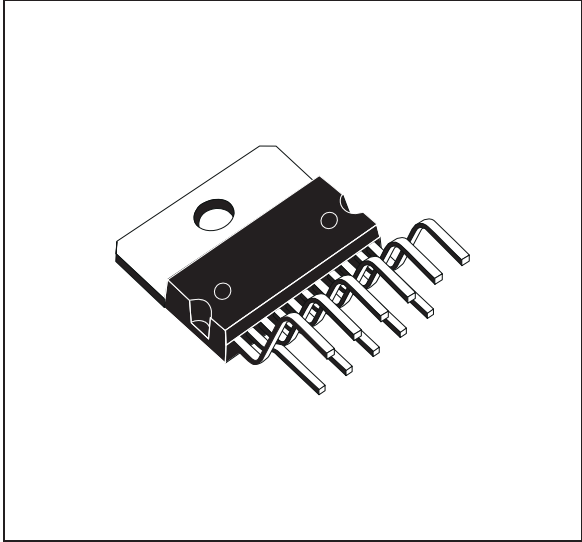

Figure 13: Overtemperature Detection



DIM.	mm			inch		
	MIN.	TYP.	MAX.	MIN.	TYP.	MAX.
A			5			0.197
B			2.65			0.104
C			1.6			0.063
D		1			0.039	
E	0.49		0.55	0.019		0.022
F	0.88		0.95	0.035		0.037
G	1.45	1.7	1.95	0.057	0.067	0.077
G1	16.75	17	17.25	0.659	0.669	0.679
H1	19.6			0.772		
H2			20.2			0.795
L	21.9	22.2	22.5	0.862	0.874	0.886
L1	21.7	22.1	22.5	0.854	0.87	0.886
L2	17.4		18.1	0.685		0.713
L3	17.25	17.5	17.75	0.679	0.689	0.699
L4	10.3	10.7	10.9	0.406	0.421	0.429
L7	2.65		2.9	0.104		0.114
M	4.25	4.55	4.85	0.167	0.179	0.191
M1	4.73	5.08	5.43	0.186	0.200	0.214
S	1.9		2.6	0.075		0.102
S1	1.9		2.6	0.075		0.102
Dia1	3.65		3.85	0.144		0.152

OUTLINE AND MECHANICAL DATA



Multiwatt11 V

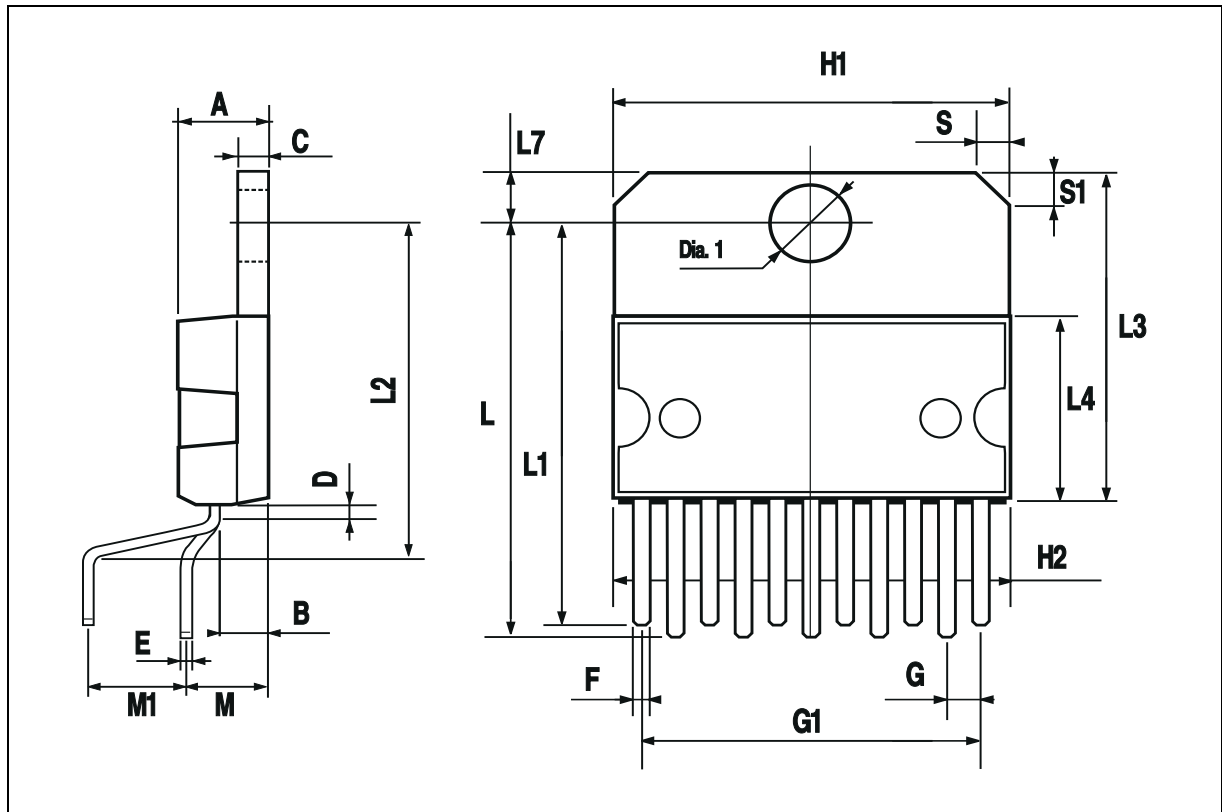

DIM.	mm			inch		
	MIN.	TYP.	MAX.	MIN.	TYP.	MAX.
A			3.6			0.142
a1	0.1		0.3	0.004		0.012
a2			3.3			0.130
a3	0		0.1	0.000		0.004
b	0.4		0.53	0.016		0.021
c	0.23		0.32	0.009		0.013
D (1)	15.8		16	0.622		0.630
D1	9.4		9.8	0.370		0.386
E	13.9		14.5	0.547		0.570
e		1.27			0.050	
e3		11.43			0.450	
E1 (1)	10.9		11.1	0.429		0.437
E2			2.9			0.114
E3	5.8		6.2	0.228		0.244
G	0		0.1	0.000		0.004
H	15.5		15.9	0.610		0.626
h			1.1			0.043
L	0.8		1.1	0.031		0.043
N	8° (typ.)					
S	8° (max.)					
T		10			0.394	

(1) "D and E1" do not include mold flash or protusions.
 - Mold flash or protusions shall not exceed 0.15mm (0.006")
 - Critical dimensions: "E", "G" and "a3".

OUTLINE AND MECHANICAL DATA

Weight: 1.9gr

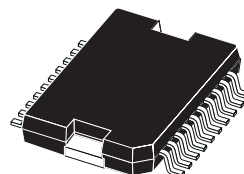

JEDEC MO-166

PowerSO20

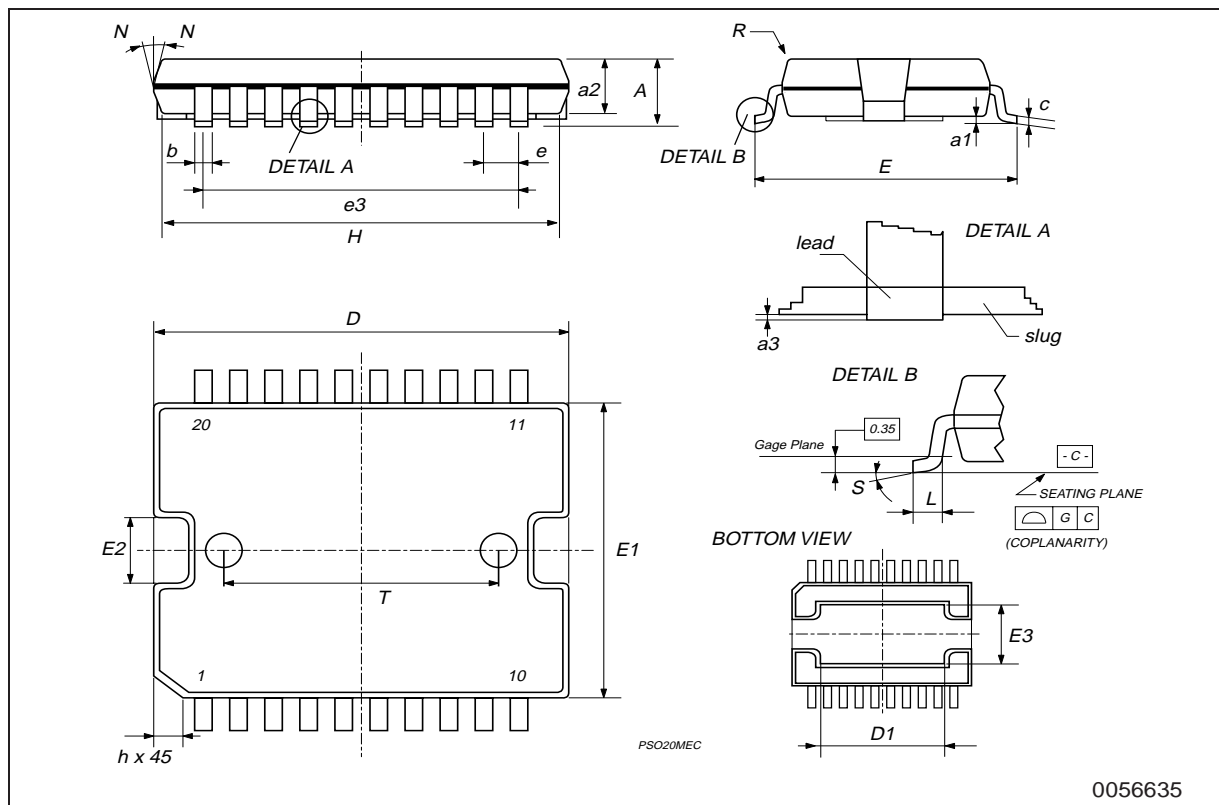

Please Read Carefully:

Information in this document is provided solely in connection with ST products. STMicroelectronics NV and its subsidiaries ("ST") reserve the right to make changes, corrections, modifications or improvements, to this document, and the products and services described herein at any time, without notice.

All ST products are sold pursuant to ST's terms and conditions of sale.

Purchasers are solely responsible for the choice, selection and use of the ST products and services described herein, and ST assumes no liability whatsoever relating to the choice, selection or use of the ST products and services described herein.

No license, express or implied, by estoppel or otherwise, to any intellectual property rights is granted under this document. If any part of this document refers to any third party products or services it shall not be deemed a license grant by ST for the use of such third party products or services, or any intellectual property contained therein or considered as a warranty covering the use in any manner whatsoever of such third party products or services or any intellectual property contained therein.

UNLESS OTHERWISE SET FORTH IN ST'S TERMS AND CONDITIONS OF SALE ST DISCLAIMS ANY EXPRESS OR IMPLIED WARRANTY WITH RESPECT TO THE USE AND/OR SALE OF ST PRODUCTS INCLUDING WITHOUT LIMITATION IMPLIED WARRANTIES OF MERCHANTABILITY, FITNESS FOR A PARTICULAR PURPOSE (AND THEIR EQUIVALENTS UNDER THE LAWS OF ANY JURISDICTION), OR INFRINGEMENT OF ANY PATENT, COPYRIGHT OR OTHER INTELLECTUAL PROPERTY RIGHT.

ST PRODUCTS ARE NOT DESIGNED OR AUTHORIZED FOR USE IN: (A) SAFETY CRITICAL APPLICATIONS SUCH AS LIFE SUPPORTING, ACTIVE IMPLANTED DEVICES OR SYSTEMS WITH PRODUCT FUNCTIONAL SAFETY REQUIREMENTS; (B) AERONAUTIC APPLICATIONS; (C) AUTOMOTIVE APPLICATIONS OR ENVIRONMENTS, AND/OR (D) AEROSPACE APPLICATIONS OR ENVIRONMENTS. WHERE ST PRODUCTS ARE NOT DESIGNED FOR SUCH USE, THE PURCHASER SHALL USE PRODUCTS AT PURCHASER'S SOLE RISK, EVEN IF ST HAS BEEN INFORMED IN WRITING OF SUCH USAGE, UNLESS A PRODUCT IS EXPRESSLY DESIGNATED BY ST AS BEING INTENDED FOR "AUTOMOTIVE, AUTOMOTIVE SAFETY OR MEDICAL" INDUSTRY DOMAINS ACCORDING TO ST PRODUCT DESIGN SPECIFICATIONS. PRODUCTS FORMALLY ESCC, QML OR JAN QUALIFIED ARE DEEMED SUITABLE FOR USE IN AEROSPACE BY THE CORRESPONDING GOVERNMENTAL AGENCY.

Resale of ST products with provisions different from the statements and/or technical features set forth in this document shall immediately void any warranty granted by ST for the ST product or service described herein and shall not create or extend in any manner whatsoever, any liability of ST.

ST and the ST logo are trademarks or registered trademarks of ST in various countries.

Information in this document supersedes and replaces all information previously supplied.

The ST logo is a registered trademark of STMicroelectronics. All other names are the property of their respective owners.

© 2013 STMicroelectronics - All rights reserved

STMicroelectronics group of companies

Australia - Belgium - Brazil - Canada - China - Czech Republic - Finland - France - Germany - Hong Kong - India - Israel - Italy - Japan - Malaysia - Malta - Morocco - Philippines - Singapore - Spain - Sweden - Switzerland - United Kingdom - United States of America

www.st.com



Looking for pricing, stock, or lifecycle information?

Click below to explore more details on WIN SOURCE:

 [View L9930PD](#) on WIN SOURCE

 [STMicroelectronics](#) Information

Optimize Your Supply Chain with WIN SOURCE Solutions

-  Global Sourcing Solution
-  Obsolete Management
-  Cost Control Management
-  Shortage Management
-  Alternative Solution
-  Excess Inventory Management