



**THE DATASHEET OF  
L9686MD013TR**



## AUTOMOTIVE DIRECTION INDICATOR

- RELAY DRIVER IN CAR DIRECTION INDICATORS
- FLASH FREQUENCY DOUBLES TO INDICATE LAMP FAILURE
- DUMP PROTECTION ( $\pm 80$  V)
- REVERSE BATTERY PROTECTION

### DESCRIPTION

The L9686 is a two frequency oscillator particularly suitable as relay driver for flashing light control in automotive applications. The circuit may be also used for other warning lamps like "handbrake on" etc. The lamp failure detection is given by doubling the flash repetition frequency. The L9686 is supplied in minidip 8-lead and SO8 plastic packages.

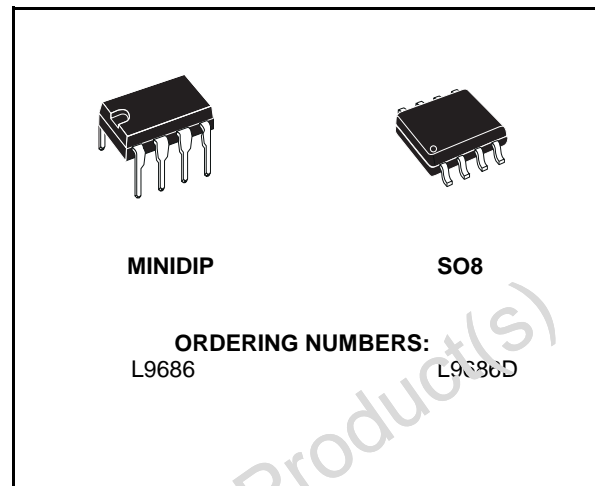

### BLOCK DIAGRAM

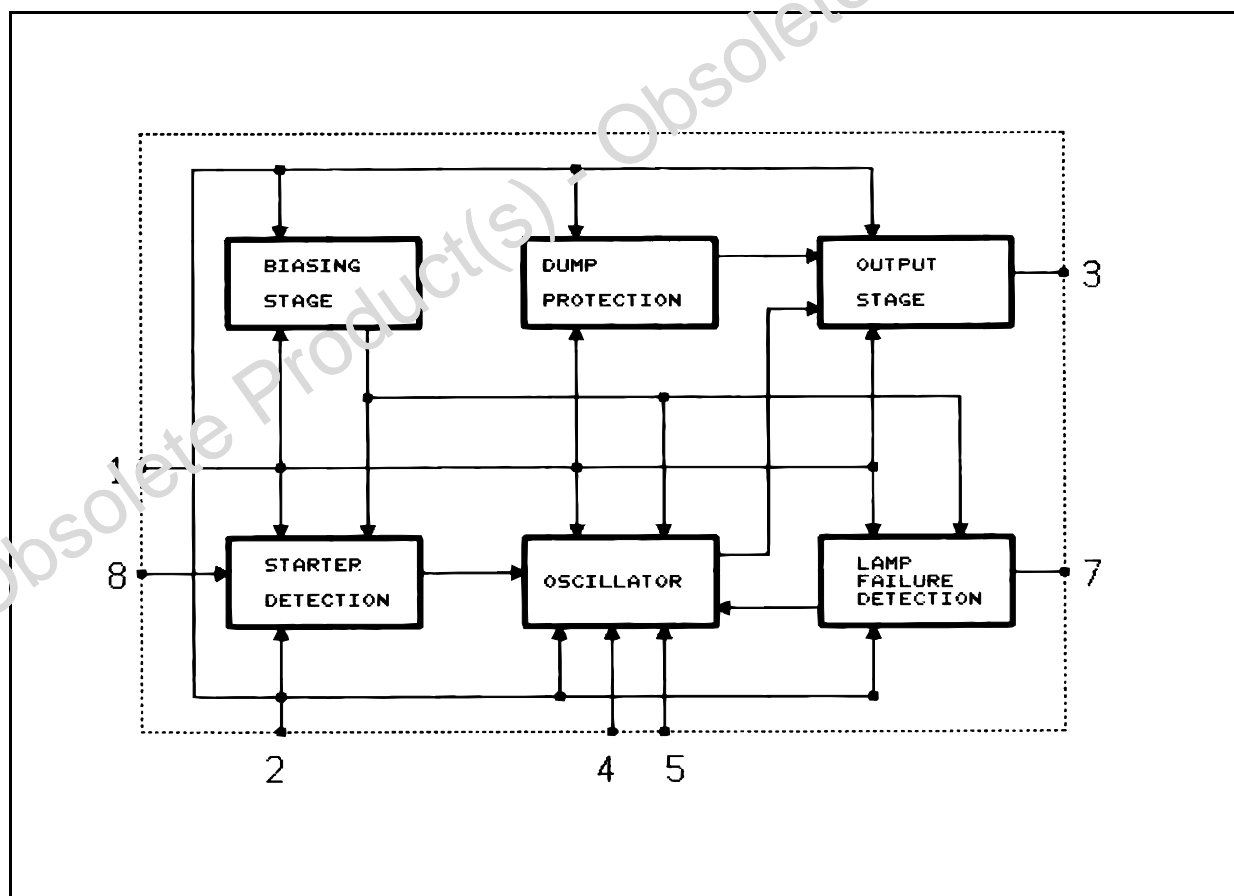

## PIN CONNECTION (Top view)

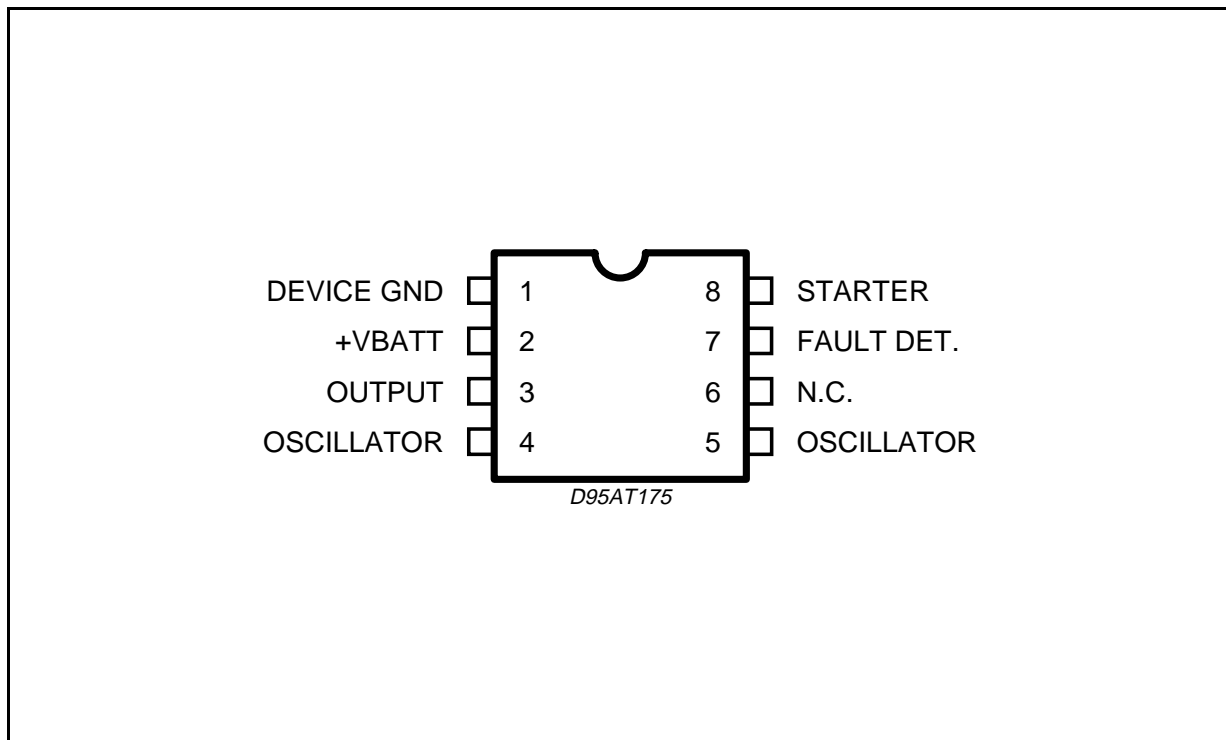

## ABSOLUTE MAXIMUM RATINGS

Symbol	Parameter	Value	Unit
$V_s$	Transient Peak Supply Voltage ( $R_3 \geq 220\Omega$ ):	80	V
	Load Dump: $5\text{ms} \leq t_{\text{rise}} \leq 10\text{ms}$ $\tau_f$ Fall Time Constant = 100ms $R_{\text{source}} \geq 0.5\Omega$		
	Field Decay: $5\text{ms} \leq t_{\text{fall}} \leq 10\text{ms}$ , $R_{\text{source}} \geq \Omega$ $\tau_r$ Rise Time Constant = 33ms		
	Low Energy Spike: $t_{\text{rise}} = 1\mu\text{s}$ , $t_{\text{fall}} = 2\text{ms}$ , $R_{\text{source}} > 10\Omega$	$\pm 100$	V
$T_j, T_{\text{stg}}$	Junction and Storage Temperature Range	- 55 to 150	$^{\circ}\text{C}$

## THERMAL DATA

Symbol	Parameter		SO8	Minidip	Unit
$R_{\text{th j-amb}}$	Thermal Resistance Junction-ambient	Max.	180	100	$^{\circ}\text{C/W}$

**ELECTRICAL CHARACTERISTICS** ( $-20^{\circ}\text{C} \leq T_{\text{amb}} \leq 100^{\circ}\text{C}$ ,  $8\text{V} \leq V_{\text{S}} \leq 18\text{V}$  unless otherwise specified.)

Symbol	Parameter	Test Condition	Min.	Typ.	Max.	Unit
$V_{\text{S}}$	Operating Voltage		8		18	V
$V_2 - V_1$	Clamping Voltage	see note 1	27		34	V
$V_2 - V_3$	Output Saturation Voltage	$I_{\text{RL}} = 250\text{mA}$			1.7	V
R2	Starter Resistance	see note 2			3.6	K $\Omega$
$K_{\text{N}}$	Oscillator Constant $K_{\text{N}}$ (normal Operation)	$F_{\text{n}} = 1/K_{\text{N}}R_{\text{o}}C_{\text{o}}$ Osc. Frequency	1.27		1.74	
$C_{\text{T}}$	Temperature Coefficient of $K_{\text{N}}$	See Note 3		-1.5 · 10-3		1/ $^{\circ}\text{C}$
D.C.	Duty Cycle (normal operation)		45	50	55	%
$K_{\text{C}}$	Oscillator Constant $K_{\text{C}}$ (lamp failure detection)	$F_{\text{C}} = 1/K_{\text{C}}R_{\text{o}}C_{\text{o}}$ Osc. Frequency	0.53		0.74	
DC <sub>LF</sub>	Duty Cycle (lamp failure detection)		35	40	45	%
$I_{\text{Q}}$	Current Consumption Relay off $I_{\text{pin 1}}$	$V_{\text{S}} = 8\text{V}$ $V_{\text{S}} = 13.5\text{V}$ $V_{\text{S}} = 18\text{V}$		2.2 2.7 3.3	3.9 4.3 4.7	mA mA mA
$V_{\text{th}}$	Lamp Failure Threshold (see note 4)	$R_3 = 220\Omega$ $V_{\text{S}} = 13.5\text{V}$ $-20 \leq T_{\text{amb}} \leq 100^{\circ}\text{C}$	65	85	95	mV

- Notes :**
1. This voltage is the threshold used to protect the circuit against overvoltage : if  $V_{\text{bat}}$  is > than this threshold, the relay will be on and the voltage across the circuit will maintain constant increasing the current in the protective resistor  $R_3$ .
  2. This is the maximum value for operation. This value must be higher than 1 K Ohms in order to limit the current in pin 8 during dumps. A recommended value for application should be 1,5 K Ohms.
  3. The external leakage from the blinker unit to ground must be with an equivalent resistor higher than 5,6 K Ohms to avoid parasitic operation when the switch  $S_1$  is off.
  4. This temperature coefficient is usefull to compensate the drift of the external timing network ( $R_1$ ,  $C_1$ ).
  5. This threshold is calculated for a 20 m Ohm shunt. The threshold is dependant of  $V_{\text{bat}}$  as the bulb current.

## FUNCTIONAL DESCRIPTION

The circuit is designed to drive the direction indicator flasher relay. The application circuit shows the typical system configuration with the external components. Its consists of a network ( $R_1$   $C_1$ ) to determine the oscillator frequency, shunt resistor ( $R_{\text{S}}$ ) to detect defective bulbs and two current limiting resistors ( $R_2/R_3$ ) to protect the IC against load dump transients.

The lightbulbs  $L_2$ ,  $L_3$ ,  $L_4$ ,  $L_5$ , are the turn signal indicators with the dashboard-light  $L_6$ . The  $S_1$  switch position is sensed across resistor  $R_2$  and  $R_{\text{lamp}}$  by input 8. The flashing cycle is started

by closing  $S_1$  : then, after a delay time  $t_{\text{d}}$  typically equal to 1.5 ms, the relay is actuated and the pin 3 goes high switching on the corresponding lamps  $L_2$ ,  $L_3$ , (or  $L_4$ ,  $L_5$ ). These lamps will flash at the oscillator frequency not depending on the battery voltage value (8 - 18 V). The flashing cycle stops and the circuit is reset to the initial position when the switch  $S_1$  is open.

The lamp failure detection function senses the current through the shunt resistor  $R_{\text{S}}$ . When one of the lightbulbs is defective the voltage drop across  $R_{\text{S}}$  is reduced to a half and the failure is indicated by doubling the flashing frequency.

Figure 1: Application Circuit.

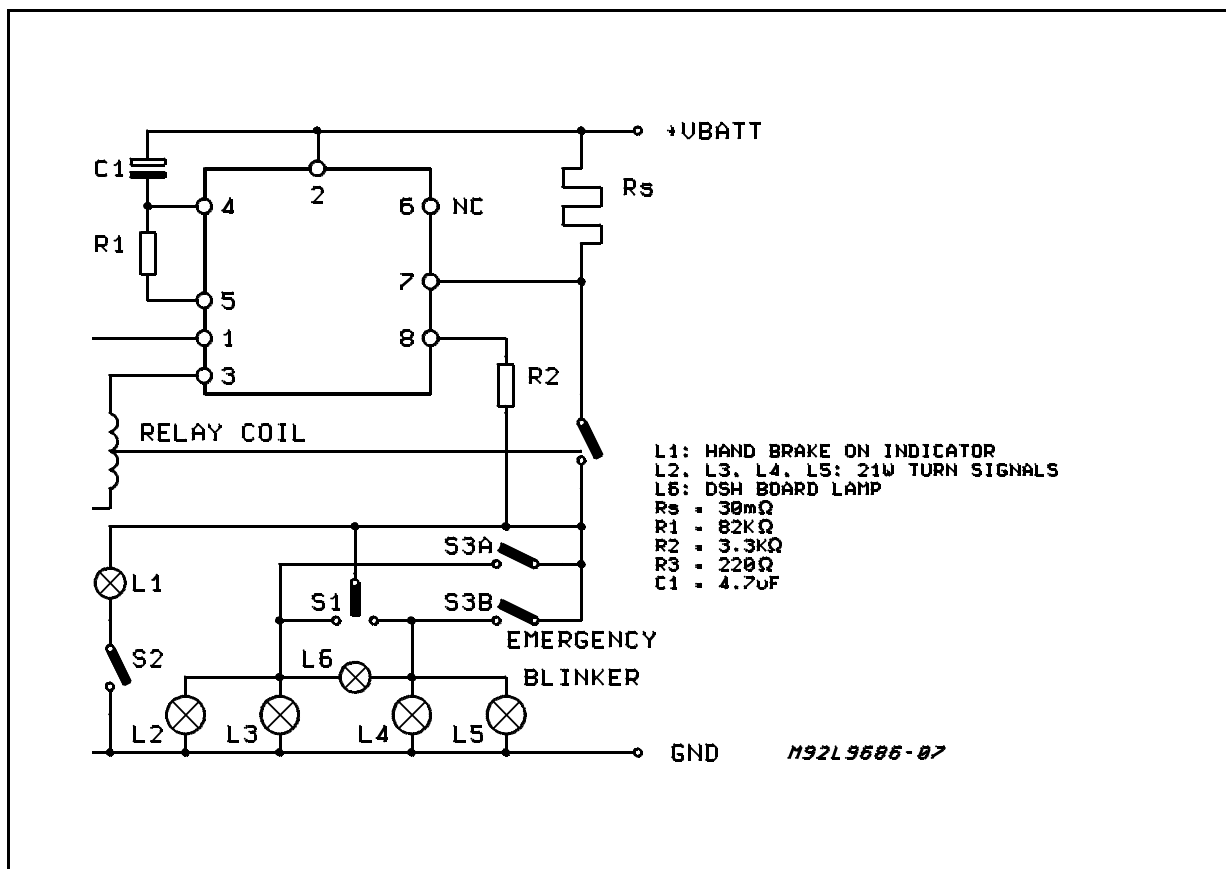

DIM.	mm			inch		
	MIN.	TYP.	MAX.	MIN.	TYP.	MAX.
A		3.32			0.131	
a1	0.51			0.020		
B	1.15		1.65	0.045		0.065
b	0.356		0.55	0.014		0.022
b1	0.204		0.304	0.008		0.012
D			10.92			0.430
E	7.95		9.75	0.313		0.384
e		2.54			0.100	
e3		7.62			0.300	
e4		7.62			0.300	
F			6.6			0.260
I			5.08			0.200
L	3.18		3.81	0.125		0.150
Z			1.52			0.060

## OUTLINE AND MECHANICAL DATA

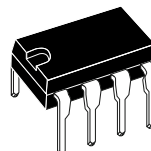

## Minidip

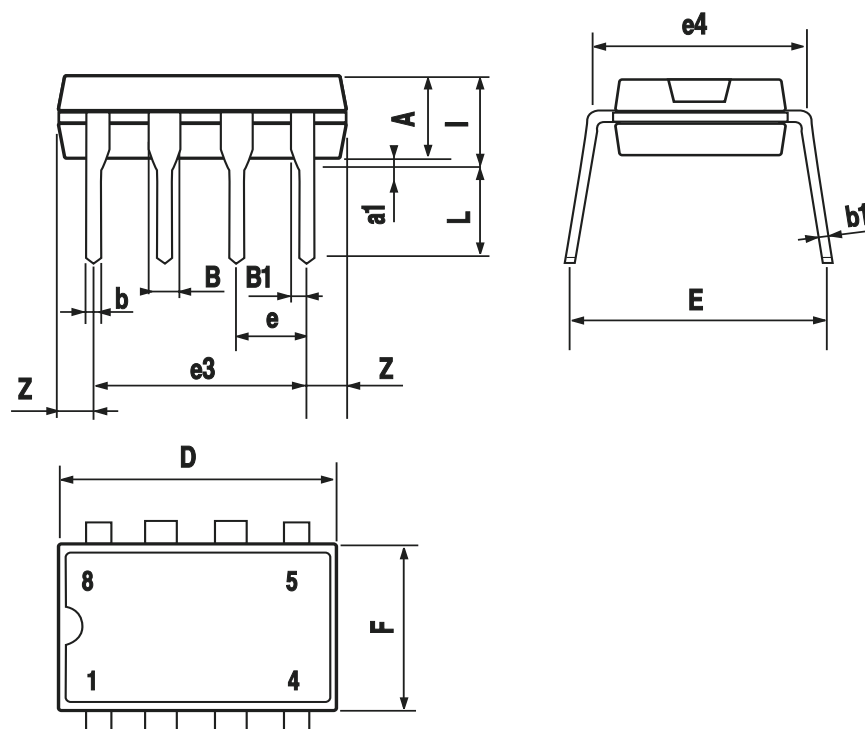

DIM.	mm			inch		
	MIN.	TYP.	MAX.	MIN.	TYP.	MAX.
A			1.75			0.069
a1	0.1		0.25	0.004		0.010
a2			1.65			0.065
a3	0.65		0.85	0.026		0.033
b	0.35		0.48	0.014		0.019
b1	0.19		0.25	0.007		0.010
C	0.25		0.5	0.010		0.020
c1	45° (typ.)					
D (1)	4.8		5.0	0.189		0.197
E	5.8		6.2	0.228		0.244
e		1.27			0.050	
e3		3.81			0.150	
F (1)	3.8		4.0	0.15		0.157
L	0.4		1.27	0.016		0.050
M			0.6			0.024
S	8° (max.)					

(1) D and F do not include mold flash or protrusions. Mold flash or protrusions shall not exceed 0.15mm (.006inch).

**OUTLINE AND MECHANICAL DATA**

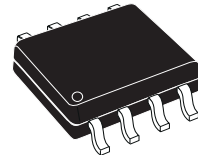

**SO8**

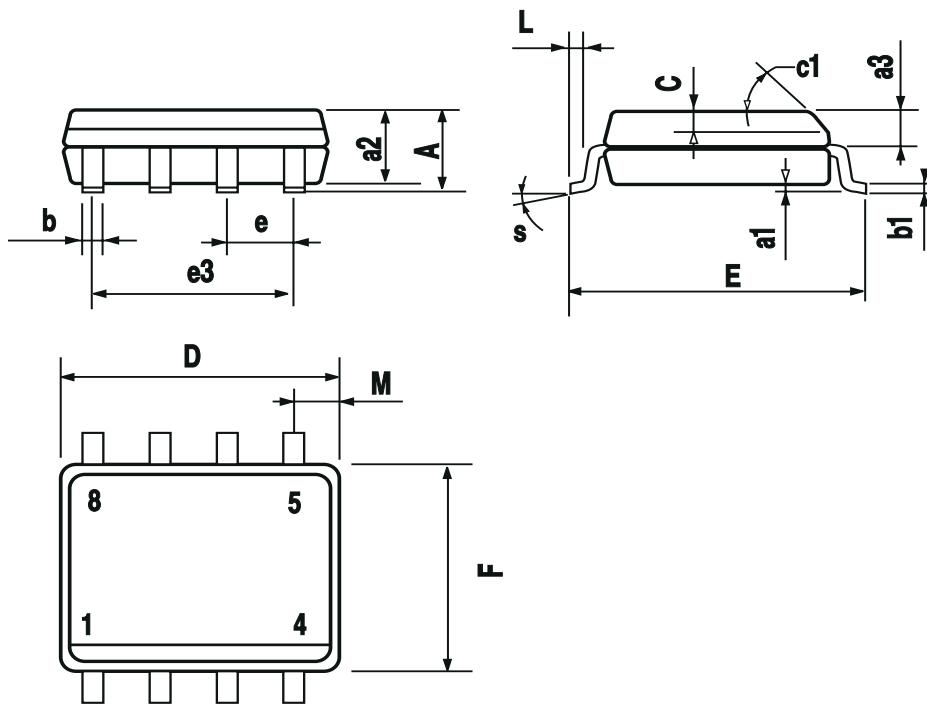

Information furnished is believed to be accurate and reliable. However, STMicroelectronics assumes no responsibility for the consequences of use of such information nor for any infringement of patents or other rights of third parties which may result from its use. No license is granted by implication or otherwise under any patent or patent rights of STMicroelectronics. Specifications mentioned in this publication are subject to change without notice. This publication supersedes and replaces all information previously supplied. STMicroelectronics products are not authorized for use as critical components in life support devices or systems without express written approval of STMicroelectronics.

The ST logo is a registered trademark of STMicroelectronics.  
All other names are the property of their respective owners

© 2003 STMicroelectronics - All rights reserved



**STMicroelectronics GROUP OF COMPANIES**

Australia – Belgium - Brazil - Canada - China – Czech Republic - Finland - France - Germany - Hong Kong - India - Israel - Italy - Japan -  
Malaysia - Malta - Morocco - Singapore - Spain - Sweden - Switzerland - United Kingdom - United States

[www.st.com](http://www.st.com)

## Looking for pricing, stock, or lifecycle information?

Click below to explore more details on WIN SOURCE:

-  [View L9686MD013TR on WIN SOURCE](#)
-  [STMicroelectronics](#) Information

## Optimize Your Supply Chain with WIN SOURCE Solutions

-  Global Sourcing Solution
-  Obsolete Management
-  Cost Control Management
-  Shortage Management
-  Alternative Solution
-  Excess Inventory Management