



THE DATASHEET OF L9333MD-TR



QUAD LOW SIDE DRIVER

- WIDE OPERATING SUPPLY VOLTAGE RANGE FROM 4.5V UP TO 32V FOR TRANSIENT 45V
- VERY LOW STANDBY QUIESCENT CURRENT TYPICALLY $< 2\mu\text{A}$
- INPUT TO OUTPUT SIGNAL TRANSFER FUNCTION PROGRAMMABLE
- HIGH SIGNAL RANGE FROM -14V UP TO 45V FOR ALL INPUTS
- 3.3V CMOS COMPATIBLE INPUTS
- DEFINED OUTPUT OFF STATE FOR OPEN INPUTS
- FOUR OPEN DRAIN DMOS OUTPUTS, WITH $R_{\text{DSon}} = 1.5\Omega$ FOR $V_{\text{S}} > 6\text{V}$ AT 25°C
- OUTPUT CURRENT LIMITATION
- CONTROLLED OUTPUT SLOPE FOR LOW EMI
- OVERTEMPERATURE PROTECTION FOR EACH CHANNEL
- INTEGRATED OUTPUT CLAMPING FOR FAST INDUCTIVE RECIRCULATION $V_{\text{FB}} > 45\text{V}$

MULTIPOWER BCD TECHNOLOGY

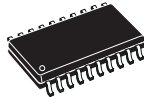

SO20 (12+4+4)

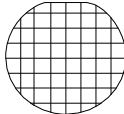

DIE

ORDERING NUMBERS:

L9333MD	(SO20 12+4+4)
L9333DIE1	(DIE)

- STATUS MONITORING FOR
 - OVERTEMPERATURE
 - DISCONNECTED GROUND OR SUPPLY VOLTAGE

DESCRIPTION

The L9333 is a monolithic integrated quad low side driver. It is intended to drive lines, lamps or relays in automotive or industrial applications.

BLOCK DIAGRAM

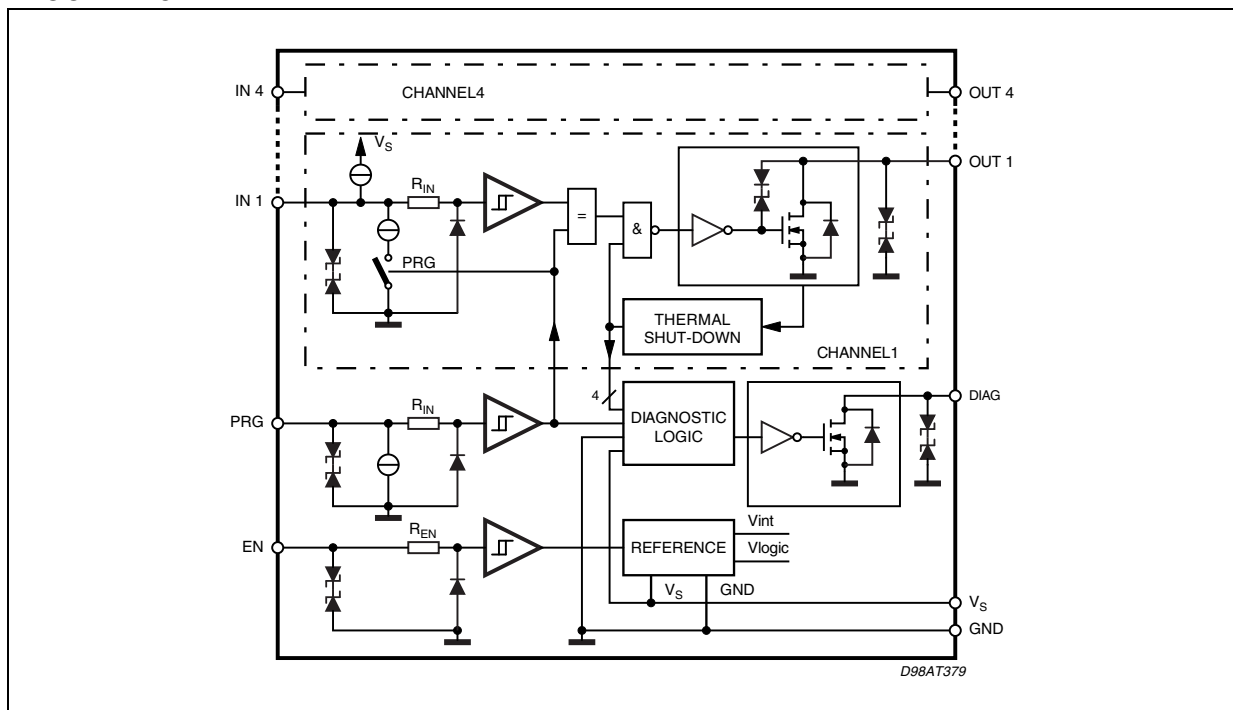

PIN CONNECTION (Top view)

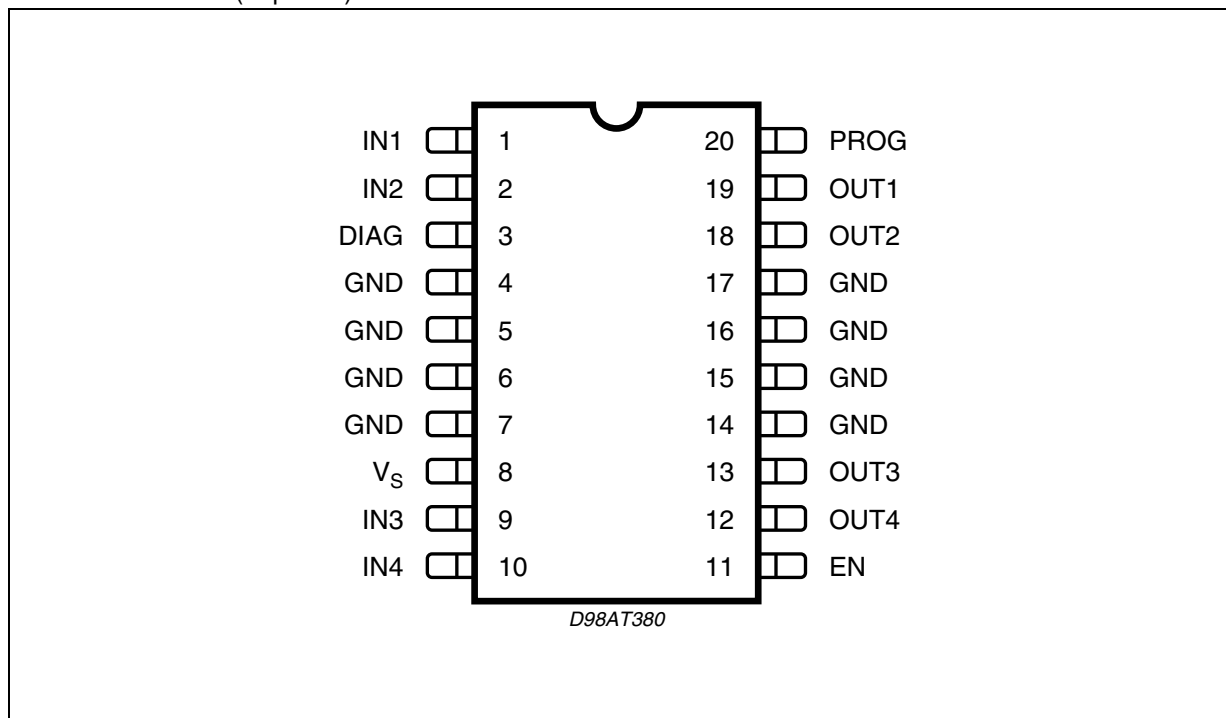

PIN FUNCTION

Pin N°	Pin Name	Description
1	IN 1	Input 1
2	IN 2	Input 2
3	DIAG	Diagnostic
4, 5, 6, 7, 14, 15, 16, 17	GND	Ground
8	VS	Supply Voltage
9	IN 3	Input 3
10	IN 4	Input 4
11	EN	Enable
12	OUT4	OUTPUT4
13	OUT 3	OUTPUT 3
18	OUT 2	OUTPUT 2
19	OUT 1	OUTPUT 1
20	PRG	Programming

ABSOLUTE MAXIMUM RATINGS

Symbol	Parameter	Value	Unit
V_S	Supply voltage DC	-0.3 to 32	V
	Supply voltage Pulse (T = 400ms)	-0.3 to 45	V
dV_S/dt	Supply voltage transient	-10 to +10	V/ μ s
V_{IN} , V_{EN} , V_{PRG}	Input, Enable, Programming Pin voltage	-14 to 45	V
V_{OUT}	Output voltage	-0.3 to 45 ¹⁾	V
V_{DIAG}	Diagnostic output voltage	-0.3 to 45	V

Note 1) : In flyback phase the output voltage can reach 60V.

ESD - PROTECTION

Parameter	Value against GND	Unit
Supply pins and signal pins	± 2	KV
Output pins	± 4	KV

Note: Human-Body-Model according to MIL 883C. The device withstand ST1 class level.

THERMAL DATA

Symbol	Parameter	Min	Typ	Max	Unit
T_{JSD}	Temperature shutdown threshold	175		220	$^{\circ}$ C
T_{JSDhys}	Temperature shutdown hysteresis		20		K
SO 12+4+4					
$R_{th(j-p)}$	Thermal resistance junction to pins			15	$^{\circ}$ C/W
$R_{th(j-a)}$	Thermal resistance junction to ambient ²⁾			50	$^{\circ}$ C/W

Note 2) : With 6cm² on board heat sink area.

LIFE TIME

Symbol	Parameter	Condition	Value	Unit
t_B	useful life time	$V_S \leq 14V$ EN = low	20	years
t_b	operating life time	$4.5V \leq V_S \leq 32V$ EN = high	5000	hours

OPERATING RANGE:

Within the operating range the IC operates as described in the circuit description, including the diagnostic table.

Symbol	Parameter	Condition	Min	Max	Unit
V _S	Supply voltage		4.5	32	V
V _{IN} , V _{EN} , V _{PRG}	Input voltage		-14	45	V
V _{OUT}	Output voltage	Voltage will be limited by internal Z-Diode clamping	-0.3	60	V
V _{DIAG}	Diagnostic output voltage		-0.3	45	V
T _J	Junction temperature		-40	150	°C

ELECTRICAL CHARACTERISTICS

The electrical characteristics are valid within the defined Operating Conditions, unless otherwise specified. The function is guaranteed by design until T_{JSDon} switch-on-threshold.

Symbol	Parameter	Test Condition	Min.	Typ.	Max.	Unit
SUPPLY						
I _Q	Quiescent current	V _S ≤ 14V; V _{EN} ≤ 0.3V T _{amb} 85 °C		< 2	10	μA
		V _S ≤ 14V; V _{EN} ≤ 0.3V T _a 150°C			50	μA
		V _S ≤ 14V; EN = high, Output = off EN = high, Output = on		1	2 3.5	mA mA
Inputs, IN1 - IN4; Programming, PRG						
V _{INlow}	Input voltage LOW		-14		1	V
V _{INhigh}	Input voltage HIGH		2		45	V
I _{IN}	Input current	0V ≤ V _{IN} ≤ 45V ³⁾	-25		50	μA
R _{IN}	Input impedance	V _{IN} < 0V; V _{IN} > V _S	10	60		kΩ

Note 3) : Current direction depends on the programming setting (PRG=high leads into a positive current see also Blockdiagram page 1)

Enable EN						
V _{ENlow}	Input voltage LOW		-14		1	V
V _{ENhigh}	Input voltage HIGH		2		45	V
R _{EN}	Input impedance	-14V < V _{EN} < 1.5V	5			kΩ
I _{EN}	Input current	1.5V < V _{EN} < 45V	5		80	μA

ELECTRICAL CHARACTERISTICS (continued)

Symbol	Parameter	Test Condition	Min.	Typ.	Max.	Unit
Outputs OUT1- OUT4						
R_{DSon}	Output ON-resistor	$V_S > 6V, I_O = 0.3A$		1.7	3.8	Ω
I_{OLeak}	Leakage current	$V_O = V_S = 14V; T_a < 125^\circ C$		1	5	μA
		$V_O = V_S = 14V; T_a < 150^\circ C$			25	μA
V_{OClamp}	Output voltage during clamping	$E_{FB} \leq 2mJ; 10 mA < I_O < 0.3A$	45	52	60	V
I_{OSC}	Short-circuit current	$V_S > 6V$	400	700	1000	mA
C_O	internal output capacities	$V_O > 4.5V$			100	pF
Diagnostic Output DIAG						
V_{Dlow}	Output voltage LOW	$I_{DL} = 0.6mA$			0.8	V
I_{Dmax}	Max. output current	internal current limitation; $V_D = 14V$	1	5	15	mA
I_{DLeak}	Leakage current	$V_D = V_S = 14 V; T_a < 125^\circ C$		0.1	1	μA
		$V_D = V_S = 14 V; T_a < 150^\circ C$			5	μA
Timing Characteristics ⁴⁾						
$t_{d,on}$	On delay time	$V_S = 14V$		2	3.5	μs
$t_{d,off}$	Off delay time	$C_{ext} = 0F; L_{ext} = 0H$		3	4.5	μs
t_{set}	Enable settling time	only testing condition			20	μs
$t_{d,DIAG}$	ON or OFF Diagnostic delay time	$10mA \leq I_O \leq 200mA$			10	μs
S_{out}	Output voltage slopes		2.5	9	16	V/ μs

Note : All parameters are measured at 125°C.

Note 4) : See also Fig.3 Timing Characteristics

Figure 1. Timing Characteristics

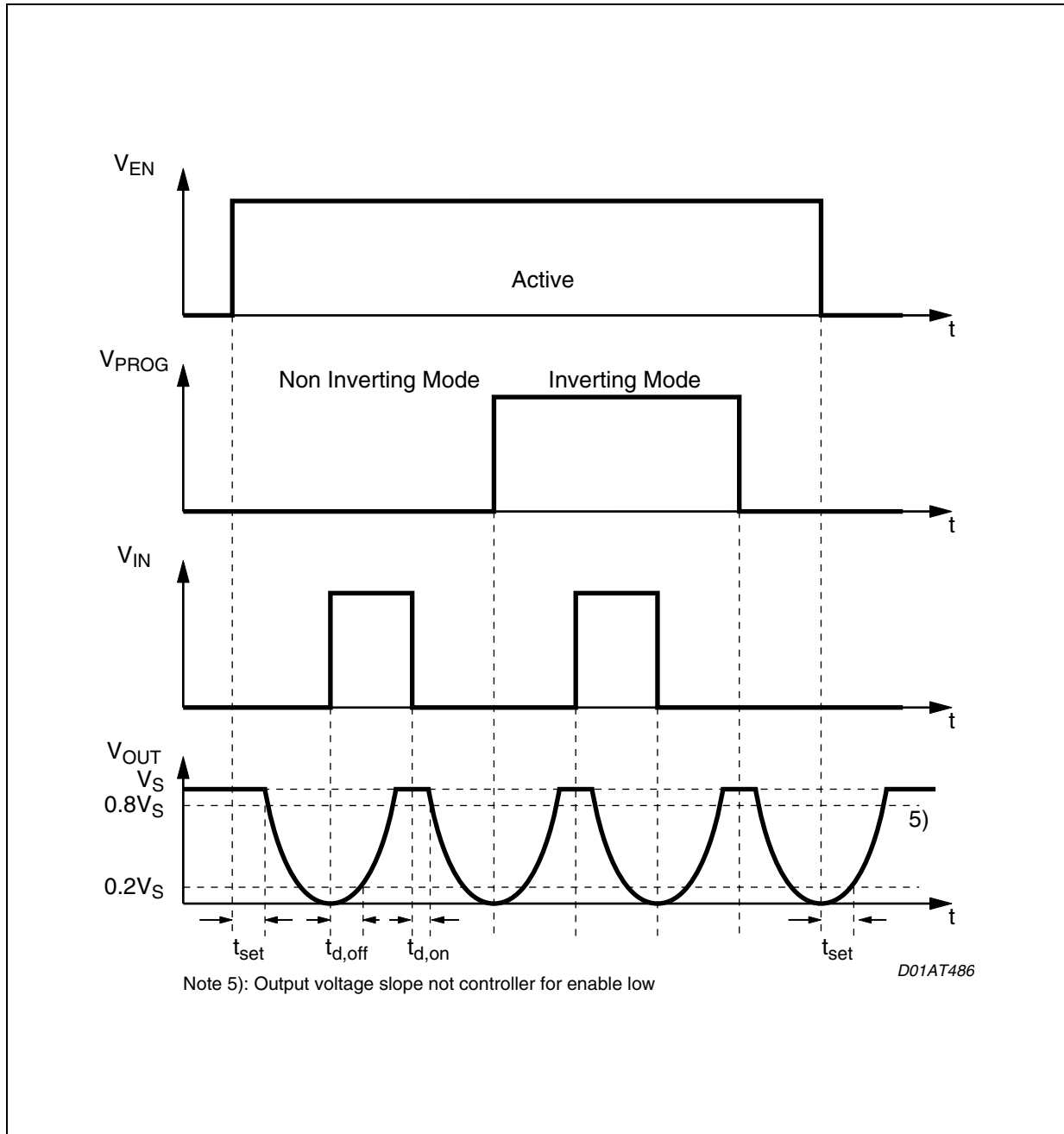

Note 5) : Output voltage slope not controlled for enable low!

FUNCTIONAL DESCRIPTION

The L9333 is a quad low side driver for lines, lamps or inductive loads in automotive and industrial applications.

The logic input levels are 3.3V CMOS compatible. This allows the device to be driven directly by a microcontroller. For the noise immunity, all input thresholds have a hysteresis of typ. 100mV. Each input (IN, EN and PRG) is protected to withstand voltages from -14V to 45V. The device is activated with a 'high' signal on ENable. ENable 'low' switches the device into the sleep mode. In this mode the quiescent current is typically less than 2 μ A. A high signal on PProGramming input changes the signal transfer polarity from noninverting to the inverting mode. This pin can be connected either to V_S or GND. If these pins are not connected, the forced status of the PRG and EN pin is low. For packaged applications it is still recommended to connect all input pins to ground respective VS to avoid EMC influence. The forced condition leads to a mode change if the PRG pin was high before the interruption. Independent of the PProGramming input, the OUTput switches off, if the signal INput pin is not connected. This function is verified using a leakage current of 5 μ A (sink for PRG=high; source for PRG=low) during circuit test.

Each output driver has a current limitation of min 0.4A and an independent thermal shut-down. The thermal shut-down deactivates that output, which exceeds temperature switch off level. When the junction temperature decreases 20K below this temperature threshold the output will be activated again. This 20K is the hysteresis of the thermal shutdown function. The Gates, of the output DMOS transistors are charged and discharged with a current source. Therefore the output slope is limited. This reduces the electromagnetic radiation. For inductive loads an output voltage clamp of typically 52V is implemented.

The DIAGnostic is an open drain output. The logic status depends on the PProGramming pin. If the PRG pin is 'low' the DIAG output becomes low, if the device works correctly. At thermal shut-down of one channel or if the ground is disconnected the DIAGnostic output becomes high. If the PRG pin is 'high' this output is switched off at normal function and switched on at overtemperature. For the fault condition of interrupted ground, the potential of VS and Diagnostic should be equal.

DIAGNOSTIC TABLE

Pins	EN	PRG	IN	OUT	DIAG
Normal function	H	L	L	L (on)	L (on)
	H	L	H	H (off)	L (on)
	H	H	L	H (off)	H (off)
	H	H	H	L (on)	H (off)
	L	X	X	H (off)	H (off)
Overtemperature, disconnected ground or supply voltage	H	L	X	H (off) *	H (off)
Overtemperature	H	H	X	H(off) *	L(on)

X = not relevant

* selective for each channel at overtemperature

Figure 2. Application for Inverting Transfer Polarity

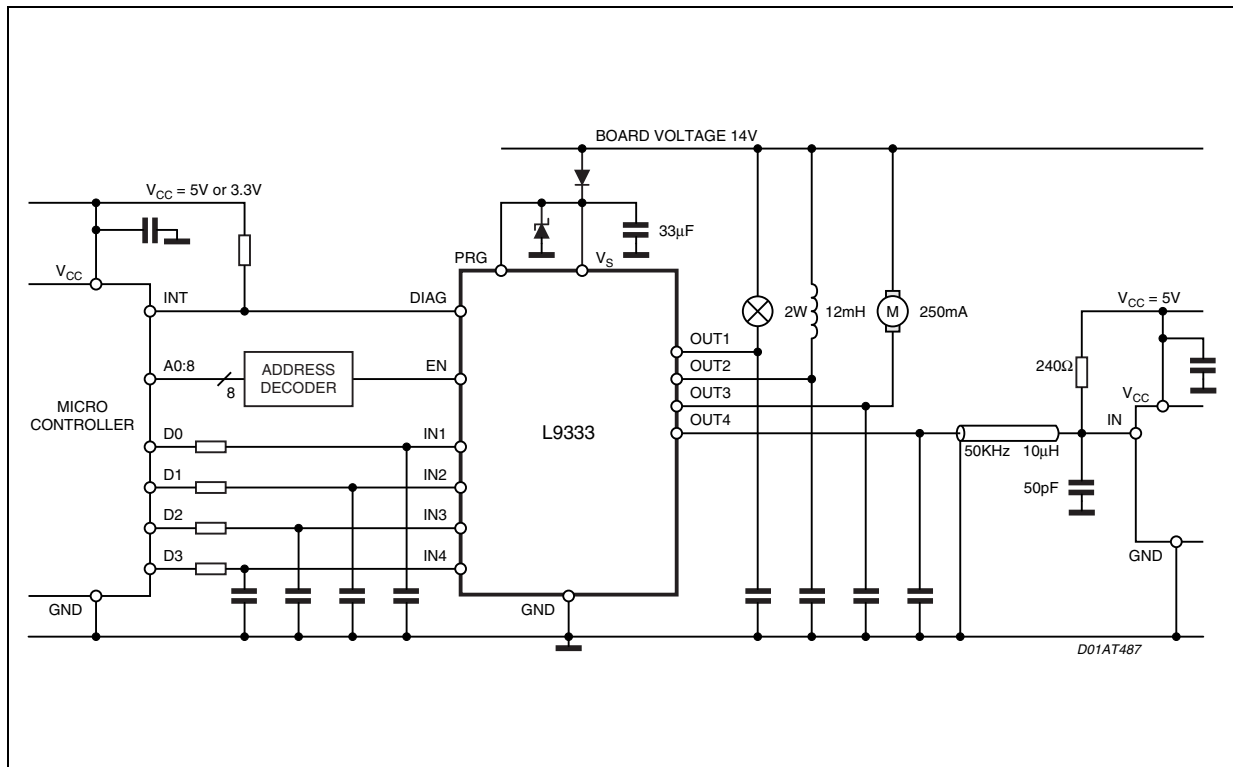
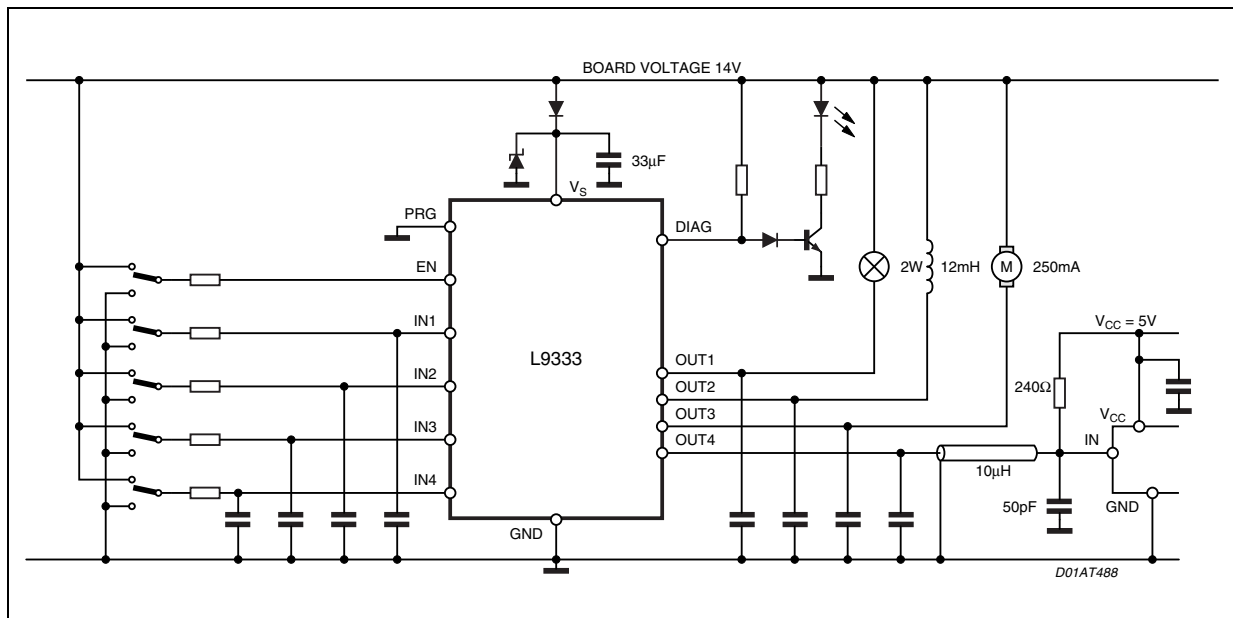

Figure 3. Application for non Inverting Transfer Polarity



Note We recommend to use the device for driving inductive loads with flyback energy $E_{FB} \leq 2mJ$.

EMC SPECIFICATION**EMS (electromagnetic susceptibility)****Measurement setup:**

DUT mounted on a specific application board is driven in a typical application circuit (see below). Two devices are stimulated by a generator to read and write bus signals. They will be monitored externally to ensure proper function.

Measurement method:

- a) The two bus lines are transferred 2m under a terminated stripline. That's where they were exposed to the RF-field. Stripline setup and measurement method is described in DIN 40839-4 or ISO 11452-5.
- b) DUT mounted on the same application board is exposed to RF through the tophole of a TEM-cell. Measurement method according SAE J1752.
- c) The two bus lines are transferred into a BCI current injection probe. Setup and measurement method is described in ISO 11452-4.

Failure criteria:

Failure monitoring is done by envelope measurement of the logic signals with a LeCroy oscilloscope with acceptance levels of 20% in amplitude and 2% time.

Limits:

The device is measured within the described setup and limits without fail function.

The Electromagnetic Susceptivity is not tested in production.

- a) Field strength under stripline of > 250V/m in the frequency range 1 - 400MHz modulation: AM 1kHz 80%.
- b) Field strength in TEM-cell of > 500V/m in the frequency range 1 - 400MHz modulation: AM 1kHz 80%.
- c) RF-currents with BCI of > 100mA in the frequency range 1 - 400MHz modulation: AM 1kHz 80%.

Measured Circuit

The EMS of the device was verified in the below described setup.

DIM.	mm			inch		
	MIN.	TYP.	MAX.	MIN.	TYP.	MAX.
A	2.35		2.65	0.093		0.104
A1	0.1		0.3	0.004		0.012
B	0.33		0.51	0.013		0.020
C	0.23		0.32	0.009		0.013
D	12.6		13	0.496		0.512
E	7.4		7.6	0.291		0.299
e		1.27			0.050	
H	10		10.65	0.394		0.419
h	0.25		0.75	0.010		0.030
L	0.4		1.27	0.016		0.050
K	0° (min.) 8° (max.)					

OUTLINE AND MECHANICAL DATA

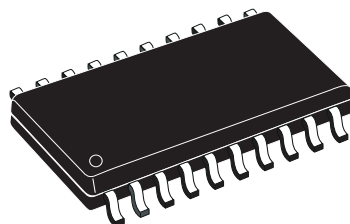

SO20 (12+4+4)

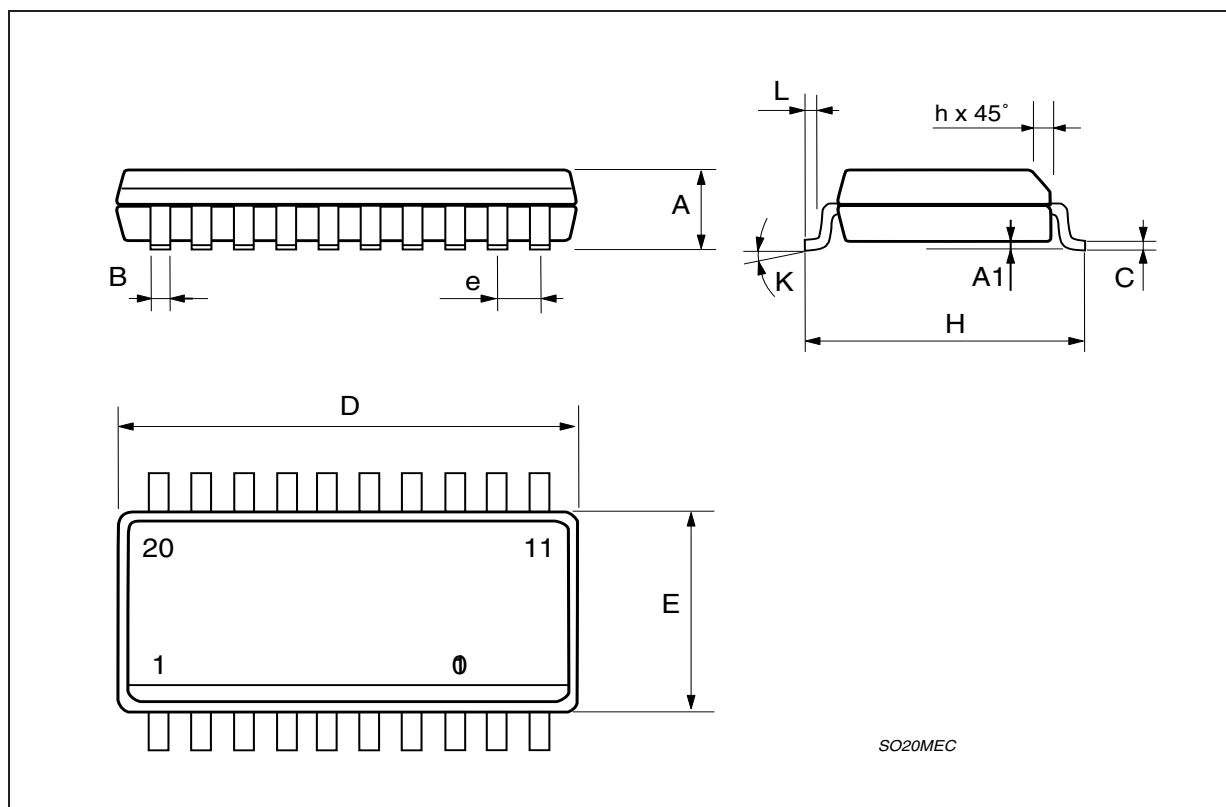

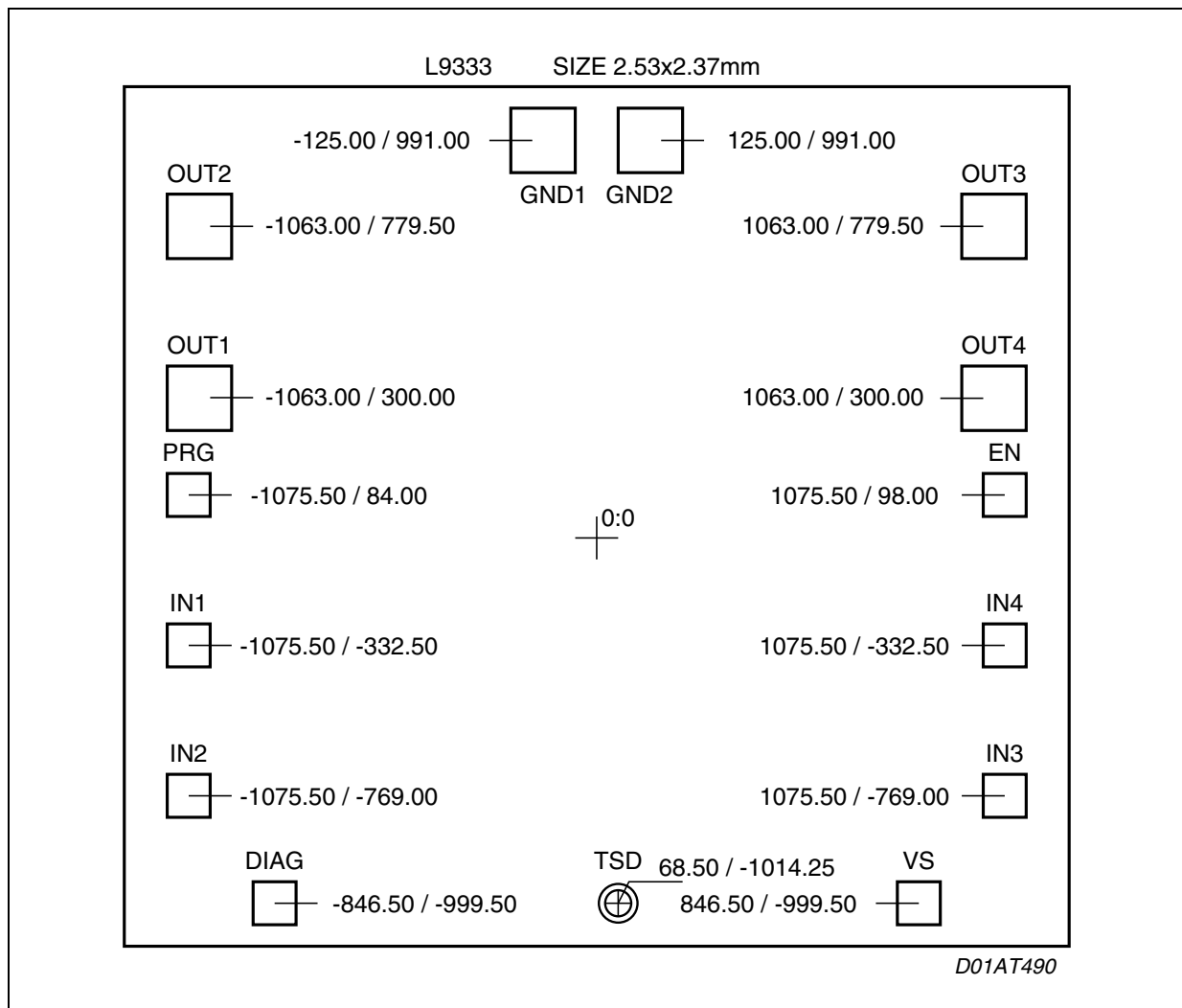

Please Read Carefully:

Information in this document is provided solely in connection with ST products. STMicroelectronics NV and its subsidiaries ("ST") reserve the right to make changes, corrections, modifications or improvements, to this document, and the products and services described herein at any time, without notice.

All ST products are sold pursuant to ST's terms and conditions of sale.

Purchasers are solely responsible for the choice, selection and use of the ST products and services described herein, and ST assumes no liability whatsoever relating to the choice, selection or use of the ST products and services described herein.

No license, express or implied, by estoppel or otherwise, to any intellectual property rights is granted under this document. If any part of this document refers to any third party products or services it shall not be deemed a license grant by ST for the use of such third party products or services, or any intellectual property contained therein or considered as a warranty covering the use in any manner whatsoever of such third party products or services or any intellectual property contained therein.

UNLESS OTHERWISE SET FORTH IN ST'S TERMS AND CONDITIONS OF SALE ST DISCLAIMS ANY EXPRESS OR IMPLIED WARRANTY WITH RESPECT TO THE USE AND/OR SALE OF ST PRODUCTS INCLUDING WITHOUT LIMITATION IMPLIED WARRANTIES OF MERCHANTABILITY, FITNESS FOR A PARTICULAR PURPOSE (AND THEIR EQUIVALENTS UNDER THE LAWS OF ANY JURISDICTION), OR INFRINGEMENT OF ANY PATENT, COPYRIGHT OR OTHER INTELLECTUAL PROPERTY RIGHT.

ST PRODUCTS ARE NOT DESIGNED OR AUTHORIZED FOR USE IN: (A) SAFETY CRITICAL APPLICATIONS SUCH AS LIFE SUPPORTING, ACTIVE IMPLANTED DEVICES OR SYSTEMS WITH PRODUCT FUNCTIONAL SAFETY REQUIREMENTS; (B) AERONAUTIC APPLICATIONS; (C) AUTOMOTIVE APPLICATIONS OR ENVIRONMENTS, AND/OR (D) AEROSPACE APPLICATIONS OR ENVIRONMENTS. WHERE ST PRODUCTS ARE NOT DESIGNED FOR SUCH USE, THE PURCHASER SHALL USE PRODUCTS AT PURCHASER'S SOLE RISK, EVEN IF ST HAS BEEN INFORMED IN WRITING OF SUCH USAGE, UNLESS A PRODUCT IS EXPRESSLY DESIGNATED BY ST AS BEING INTENDED FOR "AUTOMOTIVE, AUTOMOTIVE SAFETY OR MEDICAL" INDUSTRY DOMAINS ACCORDING TO ST PRODUCT DESIGN SPECIFICATIONS. PRODUCTS FORMALLY ESCC, QML OR JAN QUALIFIED ARE DEEMED SUITABLE FOR USE IN AEROSPACE BY THE CORRESPONDING GOVERNMENTAL AGENCY.

Resale of ST products with provisions different from the statements and/or technical features set forth in this document shall immediately void any warranty granted by ST for the ST product or service described herein and shall not create or extend in any manner whatsoever, any liability of ST.

ST and the ST logo are trademarks or registered trademarks of ST in various countries.

Information in this document supersedes and replaces all information previously supplied.

The ST logo is a registered trademark of STMicroelectronics. All other names are the property of their respective owners.

© 2013 STMicroelectronics - All rights reserved

STMicroelectronics group of companies



Australia - Belgium - Brazil - Canada - China - Czech Republic - Finland - France - Germany - Hong Kong - India - Israel - Italy - Japan - Malaysia - Malta - Morocco - Philippines - Singapore - Spain - Sweden - Switzerland - United Kingdom - United States of America

www.st.com



Looking for pricing, stock, or lifecycle information?

Click below to explore more details on WIN SOURCE:

-  [View L9333MD-TR on WIN SOURCE](#)
-  [STMicroelectronics](#) Information

Optimize Your Supply Chain with WIN SOURCE Solutions

-  Global Sourcing Solution
-  Obsolete Management
-  Cost Control Management
-  Shortage Management
-  Alternative Solution
-  Excess Inventory Management