



**THE DATASHEET OF
L6924D013TR**



Battery charger system with integrated power switch for Li-Ion/Li-Polymer

Datasheet - production data

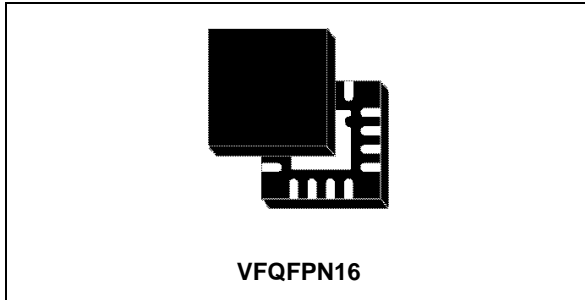

Features

- Fully integrated solution, with a power MOSFET, reverse blocking diode, sense resistor, and thermal protection
- Ideal for coke and graphite anode single-cell Li-Ion packs
- Both linear and quasi-pulse operation
- Closed loop thermal control
- USB BUS-compatible
- Programmable charge current up to 1 A
- Programmable pre-charge current
- Programmable end-of-charge current
- Programmable pre-charge voltage threshold
- Programmable charge timer
- Programmable output voltage at 4.1 V and 4.2 V, with $\pm 1\%$ output voltage accuracy
- (NTC) or (PTC) thermistor interface for battery temperature monitoring and protection
- Flexible charge process termination
- Status outputs to drive LEDs or to interface with a host processor
- Small VFQFPN 16-lead package (3 x 3 mm)

Applications

- Handheld devices
- Digital cameras
- Standalone chargers
- USB-powered chargers

Table 1. Device summary

Order code	Package	Packaging
L6924D013TR	VFQFPN16	Tape and reel

Contents

- 1 Description 4**
- 2 Pin description and connection diagrams 5**
 - 2.1 Pin description 5
- 3 Maximum ratings 7**
 - 3.1 Absolute maximum ratings 7
 - 3.2 Thermal data 7
- 4 Electrical specifications 8**
 - 4.1 Electrical characteristics 8
- 5 Block diagram 10**
- 6 Operation description 11**
 - 6.1 Linear mode 12
 - 6.2 Quasi-pulse mode 14
- 7 Application information: charging process 17**
 - 7.1 Charging process flow chart 17
 - 7.2 Pre-charge current 18
 - 7.3 Pre-charge voltage 18
 - 7.4 Fast charge current 19
 - 7.5 End-of-charge current 20
 - 7.6 Recharge flow chart 21
 - 7.7 Recharge threshold 21
 - 7.8 Maximum charging time 22
 - 7.9 Termination modes 23
- 8 Application information: monitoring and protection 24**
 - 8.1 NTC thermistor 24
 - 8.2 Battery absence detection 28
 - 8.3 Status pins 29

8.4	Shutdown	30
9	Additional application information	31
9.1	Selecting the input capacitor	31
9.2	Selecting the output capacitor	31
9.3	Battery floating voltage setup	32
9.3.1	Battery floating voltage: V_{FLOAT}	33
9.4	Layout guidelines and demonstration board description	33
10	Application ideas	37
10.1	USB battery charger	37
11	Package information	38
11.1	VFQFPN16 package information	39
12	Revision history	40

1 Description

The L6924D is a fully monolithic battery charger dedicated to single-cell Li-Ion/Polymer battery packs. It is the ideal solution for space-limited applications, like handheld equipment, and digital cameras. It integrates all of the power elements (the power MOSFET, reverse blocking diode and the sense resistor) in a small VFQFPN16 (3 x 3 mm) package. When an external voltage-regulated wall adapter is used, the L6924D works in linear mode, and charges the battery in a constant current/constant voltage (CC/CV) profile. Moreover, when a current-limited adapter is used, the device can operate in quasi-pulse mode, dramatically reducing the power dissipation. Regardless of the charging approach, a closed-loop thermal control avoids device overheating. The device has an operating input voltage ranging from 2.5 V to 12 V. The L6924D allows the user to program many parameters, such as pre-charge current, fast-charge current, pre-charge voltage threshold, end-of-charge current threshold, and charge timer. The L6924D offers two open collector outputs for diagnostic purposes, which can be used to either drive two external LEDs or communicate with a host microcontroller. Finally, the L6924D also provides very flexible control of the charge process termination and gas gauge capability, as well as other functions, such as checking for battery presence, and monitoring and protecting the battery from unsafe thermal conditions.

Figure 1. Minimum application size

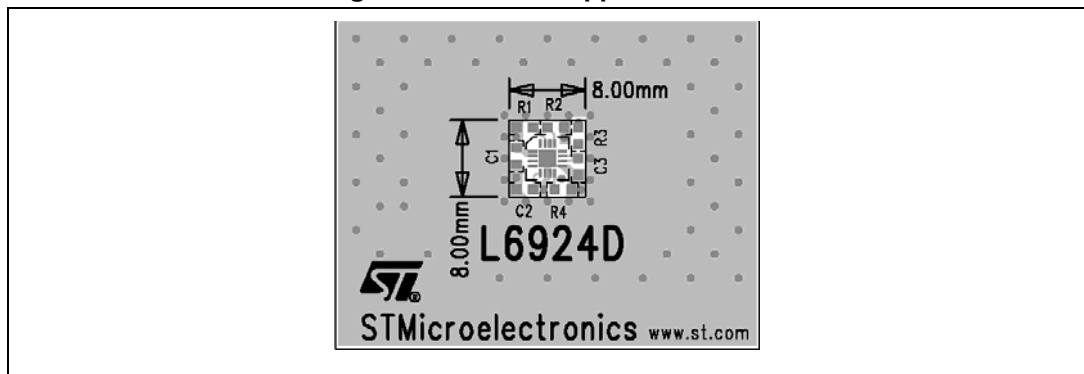
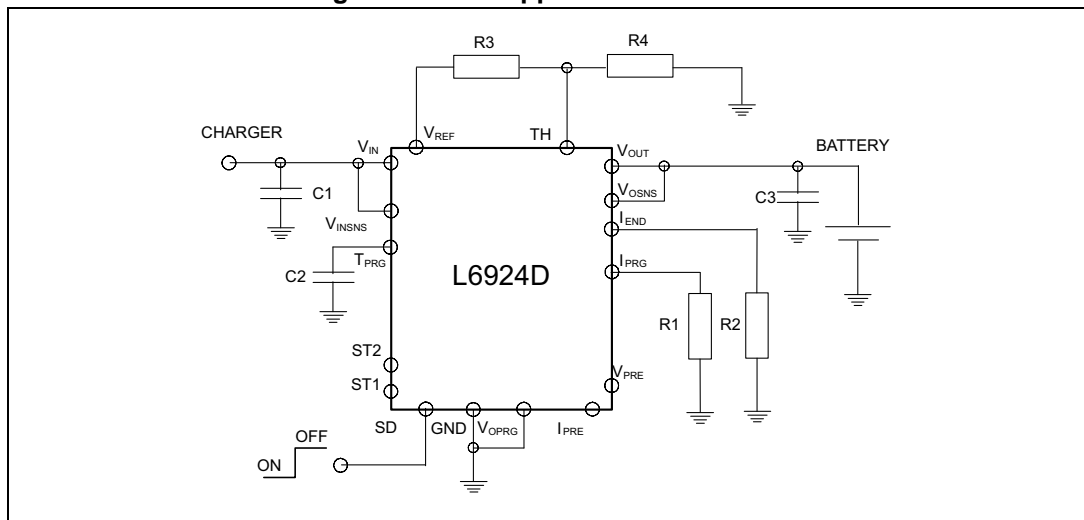
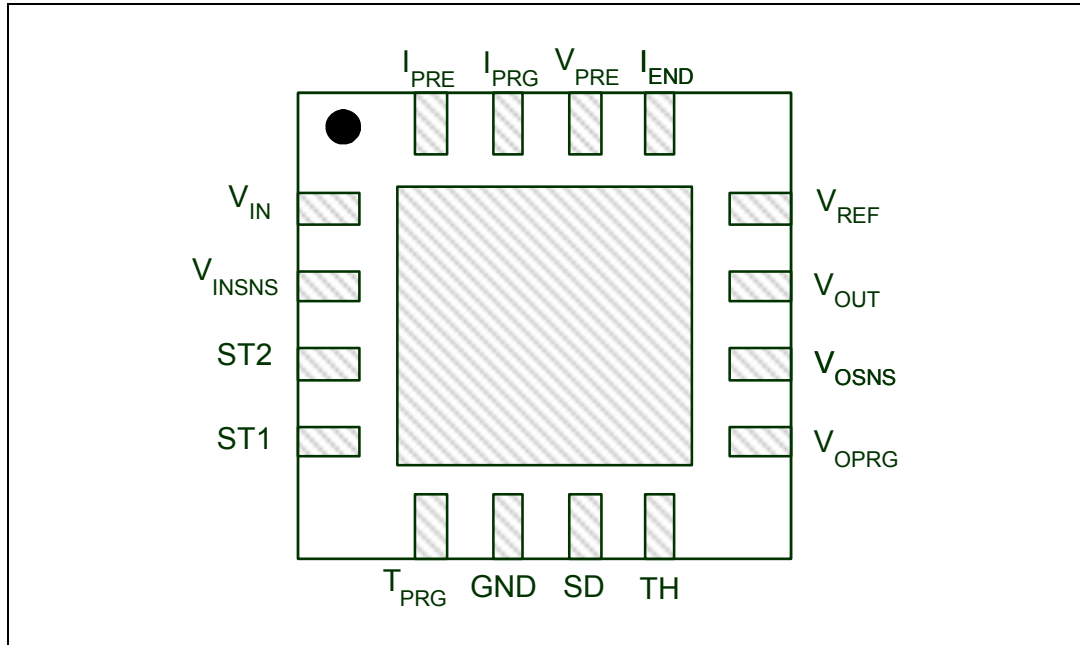

Figure 2. Basic application schematic



2 Pin description and connection diagrams

Figure 3. Pin connections (top view)



2.1 Pin description

Table 2. Pin functions

Pin	I/O	Name	Pin description
1	I	V_{IN}	Input pin of the power stage.
2	I	V_{INSNS}	Supply voltage pin of the signal circuitry. The operating input voltage ranges from 2.5 V to 12 V and the start-up threshold is 4 V.
3-4	O	ST ₂ -ST ₁	Open-collector status pins.
5	I	T _{PRG}	Maximum charging time program pin. It must be connected with a capacitor to GND to fix the maximum charging time, see Chapter 7.8: Maximum charging time on page 22
6	-	GND	Ground pin.
7	I	SD	Shutdown pin. When connected to GND enables the device; when floating disables the device.
8	I	TH	Temperature monitor pin. It must be connected to a resistor divider including an NTC or PTC resistor. The charge process is disabled if the battery temperature (sensed through the NTC or PTC) is out of the programmable temperature window see Chapter 8.1: NTC thermistor on page 24 .
9	I	V _{OPRG}	Output voltage selection pin. $V_{OUT} = 4.1$ V if left floating. $V_{OUT} = 4.2$ V if connected to GND.
10	I	V _{OSNS}	Output voltage sense pin. It senses the battery voltage to control the voltage regulation loop.
11	O	V _{OUT}	Output pin. (connected to the battery)

Table 2. Pin functions

12	O	V _{REF}	External reference voltage pin.(reference voltage is 1.8 V±2%)
13	I/O	I _{END}	Charge termination pin. A resistor connected from this pin to GND fixes the charge termination current threshold I _{ENDTH} : if I < I _{ENDTH} , the charger behaves according to the V _{PRE} status (see Chapter 7.5: End-of-charge current on page 20). The voltage across the resistor is proportional to the current delivered to the battery (Gas Gauge function).
14	I	V _{PRE}	Multifunction pin. A resistor connected to GND allows the user to adjust the pre-charge voltage threshold V _{PRETH} . If the pin is floating, V _{PRETH} = 2.8 V. If the voltage on V _{PRE} pin is lower than 0.8 V, V _{PRETH} = 2.8 V and the charge is not automatically terminated when I < I _{ENDTH} . If the voltage on V _{PRE} goes lower than 0.5 V (edge sensitive), the maximum charging time is reset.
15	I	I _{PRG}	Charge current program pin. A resistor connected from this pin to GND, fixes the fast charge current value (I _{CHG}), with an accuracy of 7%.
16	I	I _{PRE}	Pre-charge current program pin. If the pin is floating I _{PRETH} is equal to 10% of I _{CHG} . If I _{PRETH} has to be programmed at a different value, the pin has to be connected to GND or V _{REF} through a resistor see Chapter 7.2: Pre-charge current on page 18 .

3 Maximum ratings

Stressing the device above the rating listed in the “absolute maximum ratings” table may cause permanent damage to the device. These are stress ratings only and operation of the device at these or any other conditions above those indicated in the operating sections of this specification is not implied. Exposure to absolute maximum rating conditions for extended periods may affect device reliability.

3.1 Absolute maximum ratings

Table 3. Absolute maximum ratings

Symbol	Parameter	Value	Unit
V_{IN}	Input voltage	-0.3 to 16	V
V_{INSNS}, SD	Input voltage	-0.3 to V_{IN}	V
V_{OUT}, V_{OSNS}	Output voltage	-0.3 to 5	V
ST1, ST2	Output voltage	-0.3 to 6	V
	Output current	30	mA
$V_{REF}, TH, I_{END}, I_{PRG}$ $V_{PRE}, I_{PRE}, V_{OPRG}$ T_{PRG}, GND		-0.3 to 4	V
ST1 and TH pins	Maximum withstanding voltage range test condition: CDEAEC-Q100-002 (Normal “human body model” acceptance criteria performance)	±1.5	kV
Other pins		±2	kV

3.2 Thermal data

Table 4. Thermal data

Symbol	Parameter	Value	Unit
R_{thJA}	Thermal resistance junction to ambient ⁽¹⁾	75	°C/W
T_{STG}	Storage temperature range	-55 to 150	°C
T_J	Junction temperature range	-40 to 125	°C
P_{TOT}	Power dissipation at T= 70 °C	0.67	W

1. Device mounted on demonstration board

4 Electrical specifications

4.1 Electrical characteristics

$T_J = 25\text{ }^\circ\text{C}$, $V_{IN} = 5\text{ V}$, unless otherwise specified.

Table 5. Electrical characteristics

Symbol	Parameter	Test condition	Min	Typ	Max	Unit
$V_{IN}^{(1)}$	Operating input voltage		2.5		12	V
	Start up threshold				4.1	V
$I_{IN}^{(1)}$	Supply current	Charging mode ($R_{PRG} = 24\text{k}\Omega$)		1.8	2.5	mA
		Shutdown mode ($R_{PRG} = 24\text{k}\Omega$)		60	80	μA
I_{SINK}	Current flowing from V_{OUT}	Shutdown mode ($R_{PRG} = 24\text{k}\Omega$)			500	nA
		Stand by mode ($R_{PRG} = 24\text{k}\Omega$) ($V_{IN} = 2.5\text{V} < V_{BATTERY}$)			500	nA
$V_{OUT}^{(1)}$	Battery regulated voltage	V_{OPRG} at V_{IN}	4.06	4.1	4.14	V
		V_{OPRG} at GND	4.16	4.2	4.24	V
I_{CHG}	Charge current	$R_{PRG} = 24\text{k}\Omega$	450	490	525	mA
		$R_{PRG} = 12\text{k}\Omega$	905	975	1045	mA
I_{PRECH}	Pre-Charge current [default value = 10% I_{CHG}]	I_{PRE} floating $R_{PRG} = 24\text{k}\Omega$	41	49	56	mA
I_{PRECH}	Pre-Charge current	$R_{PRE} = 62\text{k}\Omega$ to GND; $R_{PRG} = 24\text{k}\Omega$	57	67	78	mA
I_{PRECH}	Pre-Charge current	$R_{PRE} = 39\text{k}\Omega$ to V_{REF} ; $R_{PRG} = 24\text{k}\Omega$	29.5	35	40.1	mA
V_{PRETH}	Pre-Charge voltage threshold [default]	$V_{PRE} = V_{PRETH}$ Default = Floating	2.7	2.8	2.9	V
V_{PRETH}	Pre-Charge voltage threshold	$R_{VPRE} = 13\text{k}\Omega$; $R_{PRG} = 12\text{k}\Omega$	2.87	3.03	3.19	V
V_{PRETH}	Pre-Charge voltage threshold [default]. Charge termination disabled		2.7	2.8	2.9	V
I_{ENDTH}	Termination current	$R_{END} = 3\text{K}3$	12	16	20	mA
$T_{MAXCH}^{(2)}$	Maximum charging time	$C_{TPRG} = 10\text{nF}$ $R[_{PRG}] = 24\text{k}\Omega$		3		hours
$T_{MAXCH}^{(2)}$ (2)	Maximum charging time accuracy	$C_{TPRG} = 5.6\text{nF}$ $R_{PRG} = 24\text{k}\Omega$		10%		
SD_{TH}	Shutdown threshold high				2	V
	Shutdown threshold low		0.4			V
$ST_{1,2}$	Output status sink current	Status on		10		mA
$R_{DS(on)}$	Power MOSFET resistance	$R_{DS(on)}@I_{CHG} = 500\text{mA}$		280	380	$\text{m}\Omega$

Table 5. Electrical characteristics (continued)

Symbol	Parameter	Test condition	Min	Typ	Max	Unit
TH	NTC pin hot threshold voltage		10.625	12.5	14.375	%V _{REF}
	NTC pin cold threshold voltage		45	50	55	%V _{REF}

1. T_J from -40°C to 125°C.
2. Guaranteed by design.

5 Block diagram

Figure 4. Block diagram

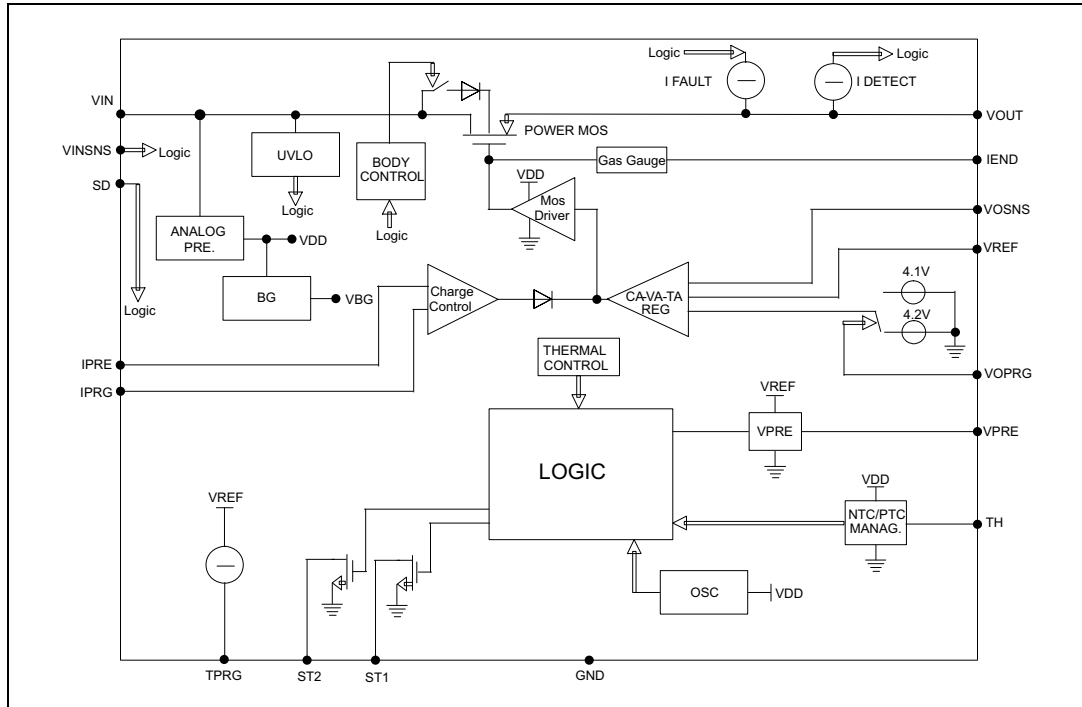

6 Operation description

The L6924D is a fully integrated battery charger that allows a very compact battery management system for space limited applications. It integrates in a small package, all the power elements: power MOSFET, reverse blocking diode and the sense resistor.

It normally works as a linear charger when powered from an external voltage regulated adapter. However, thanks to its very low minimum input voltage (down to 2.5 V) the L6924D can also work as a Quasi-Pulse charger when powered from a current limited adapter. To work in this condition, is enough to set the device's charging current higher than the adapter's one ([Chapter 7.4 on page 19](#)). The advantage of the linear charging approach is that the device has a direct control of the charging current and so the designer needn't to rely on the upstream adapter. However, the advantage of the Quasi-Pulse approach is that the power dissipated inside the portable equipment is dramatically reduced.

The L6924D charges the battery in three phases:

- **Pre-Charge constant current:** in this phase (active when the battery is deeply discharged) the battery is charged with a low current.
- **Fast-Charge constant current:** in this phase the device charges the battery with the maximum current.
- **Constant Voltage:** when the battery voltage reaches the selected output voltage, the device starts to reduce the current, until the charge termination is done.

The full flexibility is provided by:

- Programmable pre-charging current and voltage thresholds (I_{PRETH} and V_{PRETH}) ([Chapter 7.2 on page 18](#), [Chapter 7.3 on page 18](#)).
- Programmable fast-charging current (I_{CHG}) ([Chapter 7.4 on page 19](#)).
- Programmable end of charge current threshold (I_{ENDTH}) ([Chapter 7.5 on page 20](#)).
- Programmable end of charge timer (T_{MAXCH}) ([Chapter 7.8 on page 22](#)).

If the full flexibility is not required and a smaller number of external components is preferred, default values of I_{PRETH} and V_{PRETH} are available leaving the respective pins floating.

- If a PTC or NTC resistor is used, the device can monitor the battery temperature in order to protect the battery from operating in unsafe thermal conditions.
- Beside the good thermal behavior guaranteed by low thermal resistance of the package, additional safety is provided by the built-in temperature control loop. The IC monitors continuously its junction temperature. When the temperature reaches approximately 120°C, the thermal control loop starts working, and reduces the charging current, in order to keep the IC junction temperature at 120°C.
- Two open collector outputs are available for diagnostic purpose (status pins ST1 and ST2). They can be also used to drive external LEDs or to interface with a microcontroller.

The voltage across the resistor connected between I_{END} and GND gives information about the actual charging current (working as a Gas Gauge), and it can be easily fed into a μC ADC.

When the V_{PRE} pin is not used to program the Pre-Charge voltage threshold, it has two different functions:

- If the voltage across V_{PRE} pin is lower than 0.8 V, when $I < I_{ENDTH}$, the end of charge is notified by the status pin, but the charging process is not disabled. The charge process ends when the maximum charging time expires.
- If the voltage at V_{PRE} pin false under 0.5 V the timer is reset on the falling edge.

Battery disconnection control is provided thanks to the differentiated sensing and forcing output pins. A small current is sunk and forced through V_{OUT} . If V_{OSNS} doesn't detect the battery, the IC goes into a standby mode.

Figure 5 shows the real charging profile of a Li-Ion battery, with a fast charge current of 450 mA ($R_{PRG} = 26 \text{ k}\Omega$),

Figure 5. Li-Ion charging profile

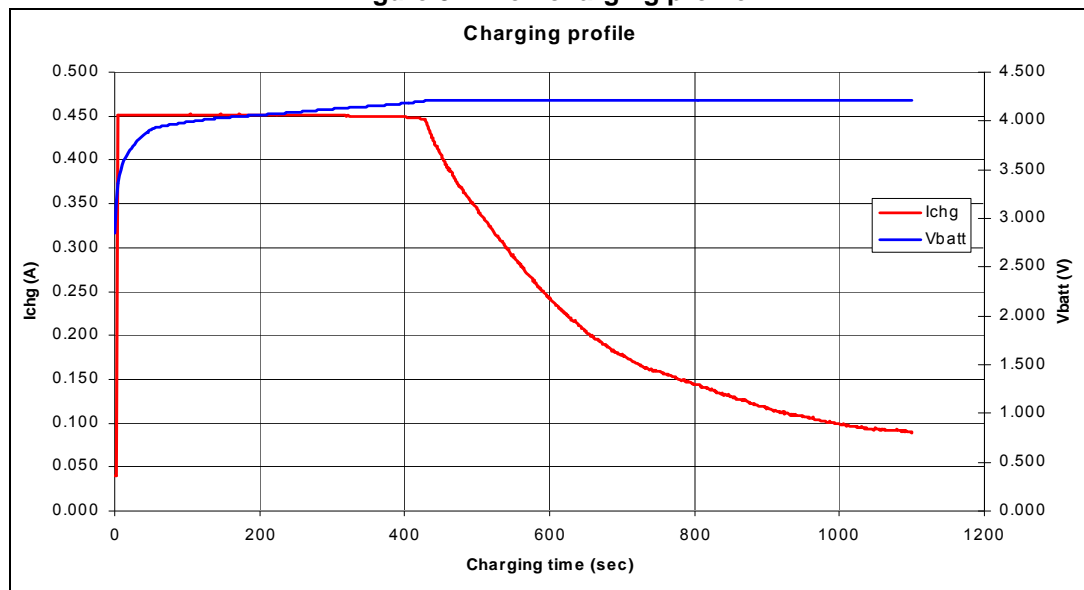

6.1 Linear mode

When operating in linear mode, the device works in a way similar to a linear regulator with a constant current limit protection.

It charges the battery in three phases:

- Pre-charging current (“Pre-Charge” phase).
- Constant current (“Fast-Charge” phase).
- Constant voltage (“Voltage Regulation” phase).

V_{ADP} is the output voltage of the upstream AC-DC adapter that is, in turn, the input voltage of the L6924D. If the battery voltage is lower than a set pre-charge voltage (V_{PRETH}), the pre-charge phase takes place. The battery is pre-charged with a low current I_{PRE} (Chapter 7.2 on page 18).

When the battery voltage goes higher than V_{PRETH} , the battery is charged with the fast charge current I_{CHG} set through an external resistor (Chapter 7.4 on page 19).

Finally, when the battery voltage is close to the regulated output voltage V_{OPRGTH} (4.1 V or 4.2 V), the voltage regulation phase takes place and the charging current is reduced. The charging process is usually terminated when the charging current reaches a set value or when a charging timer expires ([Chapter 7.9 on page 23](#)).

[Figure 6](#) shows the different phases.

Figure 6. Typical charge curves in linear mode

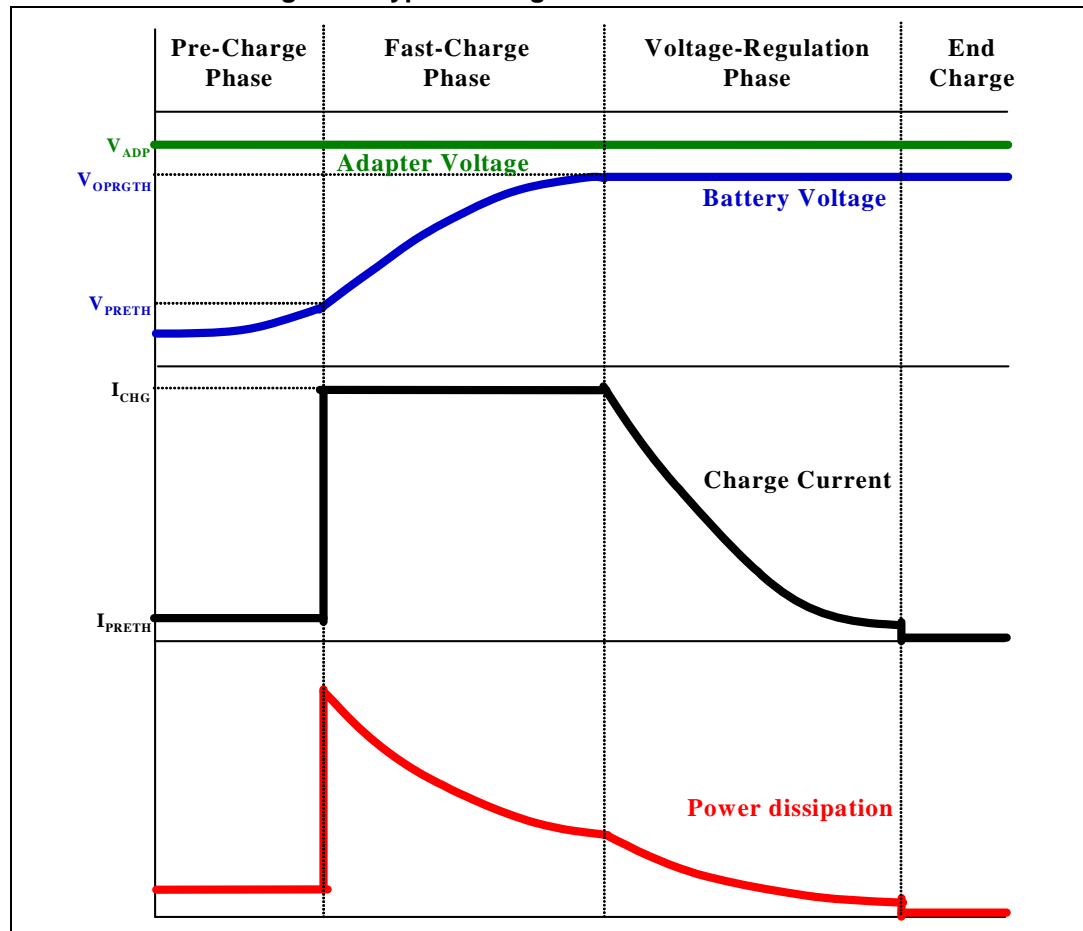

The worst case in power dissipation occurs when the device starts the fast-charge phase. In fact, the battery voltage is at its minimum value. In this case, this is the maximum difference between the adapter voltage and battery voltage, and the charge current is at its maximum value.

The power dissipated is given by the following equation:

Equation 1

$$P_{DIS} = (V_{ADP} - V_{BAT}) \times I_{CHG}$$

The higher the adapter voltage is, the higher the power dissipated. The maximum power dissipated depends on the thermal impedance of the device mounted on board.

6.2 Quasi-pulse mode

The quasi-pulse mode can be used when the system can rely on the current limit of the upstream adapter to charge the battery. In this case, I_{CHG} must be set higher than the current limit of the adapter. In this mode, the L6924D charges the battery with the same three phases as in linear mode, but the power dissipation is greatly reduced as shown in [Figure 7](#).

Figure 7. Typical charge curves in quasi pulse mode

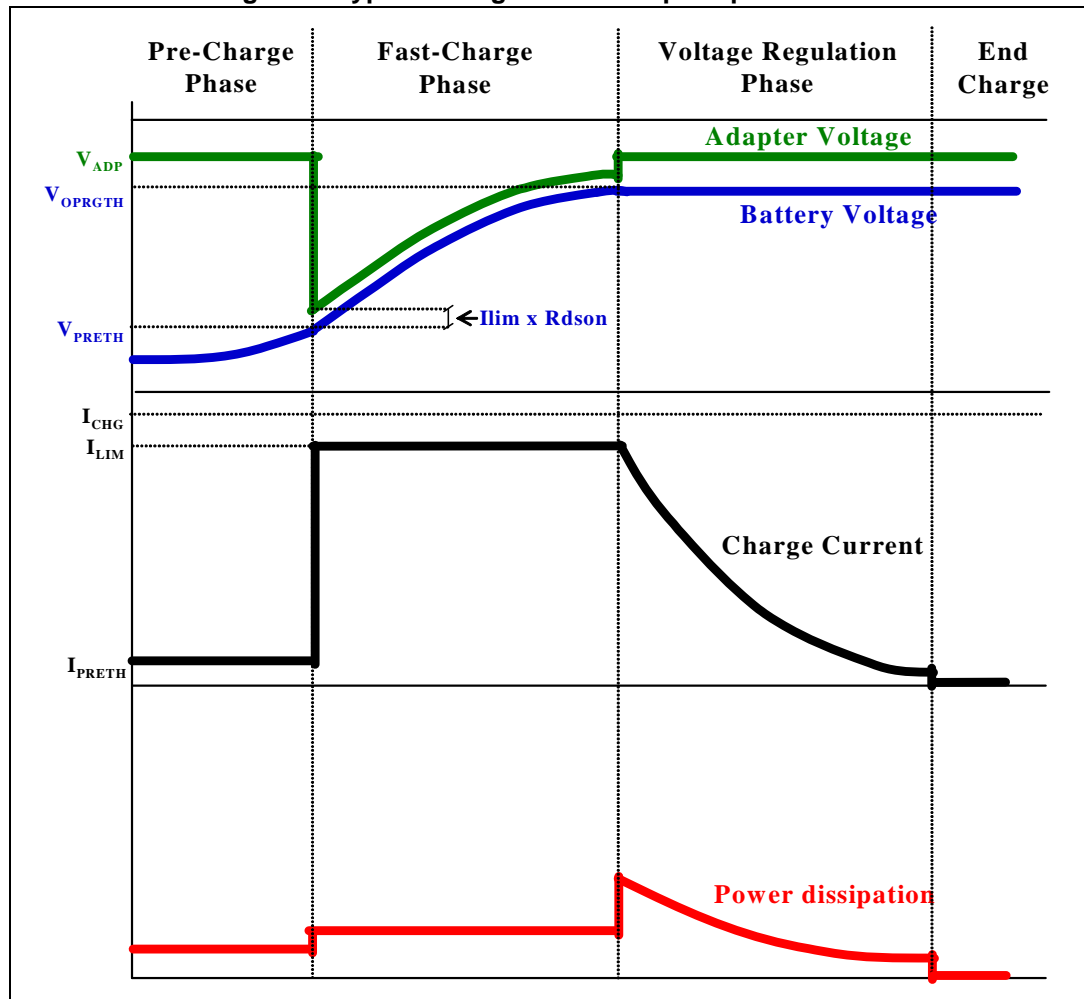

The big difference is due to the fact that I_{CHG} is higher than the current limit of the adapter. During the fast-charge phase, the output voltage of the adapter drops and goes down to the battery voltage plus the voltage drop across the power MOSFET of the charger, as shown in the following equation:

Equation 2

$$V_{IN} = V_{ADP} = V_{BAT} + \Delta V_{MOS}$$

Where ΔV_{MOS} is given by:

Equation 3

$$\Delta V_{MOS} = R_{DS(on)} \times I_{LIM}$$

Where,

I_{LIM} = current limit of the wall adapter, and $R_{DS(on)}$ = resistance of the power MOSFET.

The difference between the set charge current and the adapter limit should be high enough to minimize the $R_{DS(on)}$ value (and the power dissipation). This makes the control loop completely unbalanced and the power element is fully turned on.

Figure 8 shows the $R_{DS(on)}$ values for different output voltage and charging currents for an adapter current limit of 500 mA.

Figure 8. $R_{DS(on)}$ curves vs charging current and output voltage

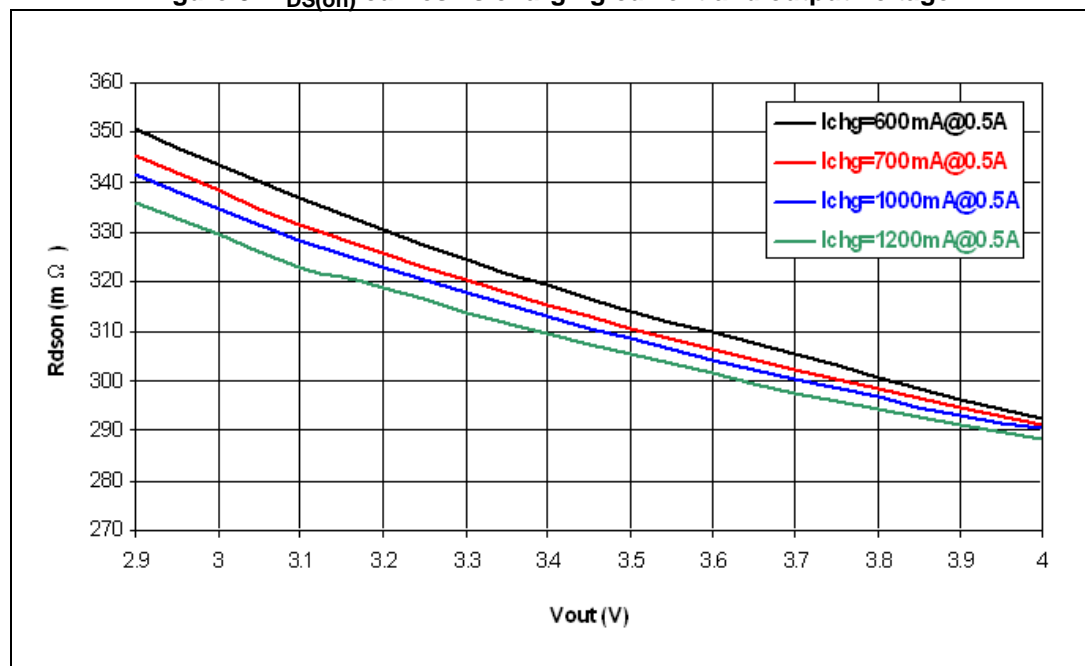

Neglecting the voltage drop across the charger (ΔV_{MOS}) when the device operates in this condition, its input voltage is equal to the battery one, and so a very low operating input voltage (down to 2.5 V) is required. The power dissipated by the device during this phase is:

Equation 4

$$P_{CH} = R_{DS(on)} \times I_{LIM}^2$$

When the battery voltage approaches the final value, the charger gets back the control of the current, reducing it. Due to this, the upstream adapter exits the current limit condition and its output goes up to the regulated voltage V_{ADP} . This is the worst case in power dissipation:

Equation 5

$$P_{DIS} = (V_{ADP} - V_{BAT}) \times I_{LIM}$$

In conclusion, the advantage of the linear charging approach is that the designer has the direct control of the charge current, and consequently the application can be very simple. The drawback is the high power dissipation.

The advantage of the Quasi-Pulse charging method is that the power dissipated is dramatically reduced. The drawback is that a dedicated upstream adapter is required.

7 Application information: charging process

7.1 Charging process flow chart

Figure 9. Charging process flow chart

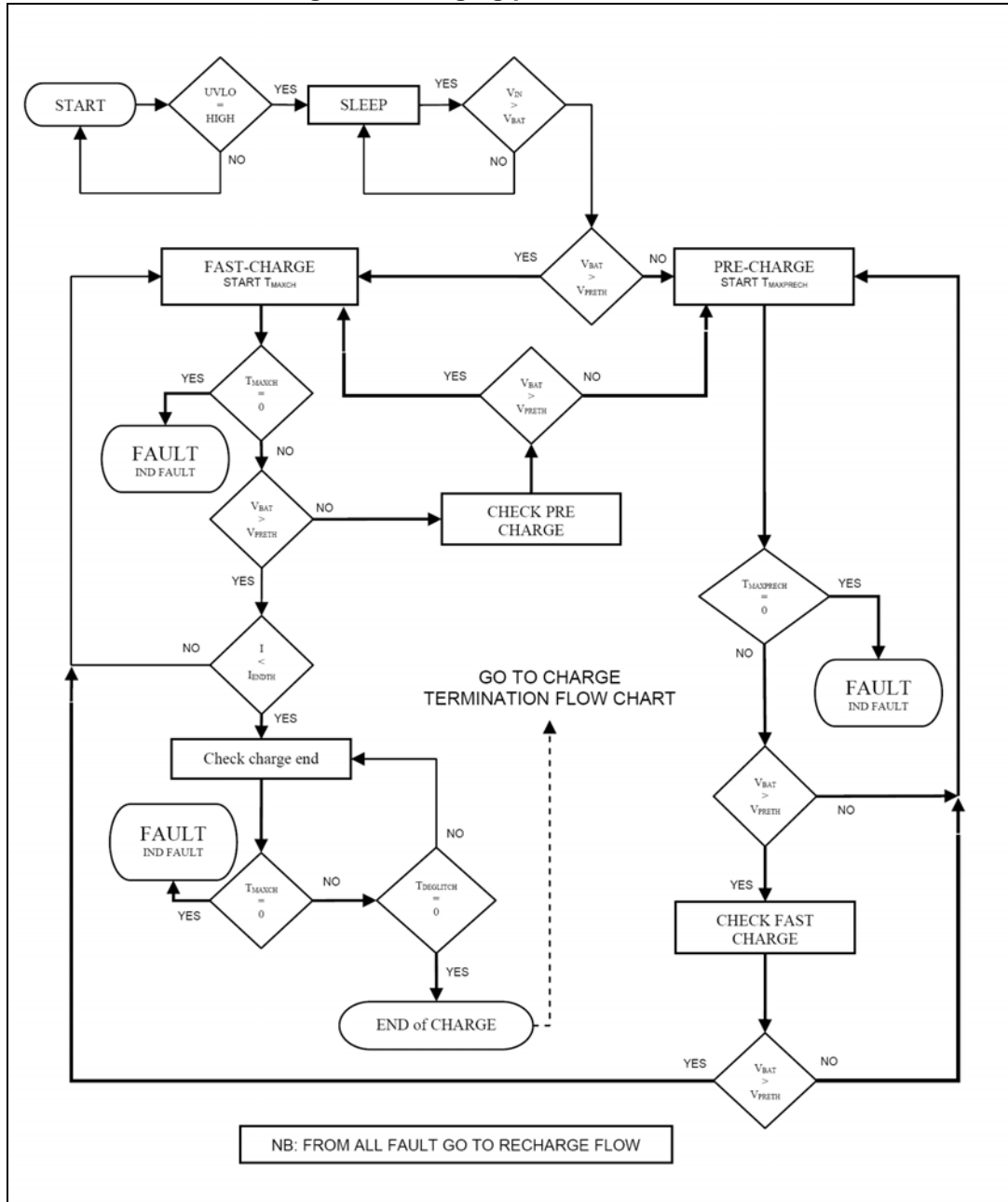

7.2 Pre-charge current

The L6924D allows pre-charging the battery with a low current when the battery voltage is lower than a specified threshold (V_{PRETH}). The Pre-charge current has a default value equal to 10% of the fast-charge current. However it can be adjusted by connecting a resistor from the I_{PRE} pin to GND or V_{REF} (see [Figure 10](#)). When the resistor is connected between I_{PRE} pin and GND, the current is higher than the default value. The R_{PRE} value is given by:

Equation 6

$$R_{PRE} = \frac{V_{BG}}{\frac{I_{PRECH}}{K_{PRE}} - \frac{V_{BG}}{R_{PRG}}}$$

Figure 10. I_{PRE} pin connection



When R_{PRE} is connected to V_{REF} , the current is lower than the default value. V_{REF} is the external reference equal to 1.8 V, V_{BG} is the internal reference equal to 1.23 V and K_{PRE} is a constant equal to 950. See [Figure 11](#).

The relationship is shown in the equation 7:

Equation 7

$$R_{PRE} = \frac{V_{REF} - V_{BG}}{\frac{V_{BG}}{R_{PRG}} - \frac{I_{PRECH}}{K_{PRE}}}$$

Figure 11. I_{PRE} pin connection

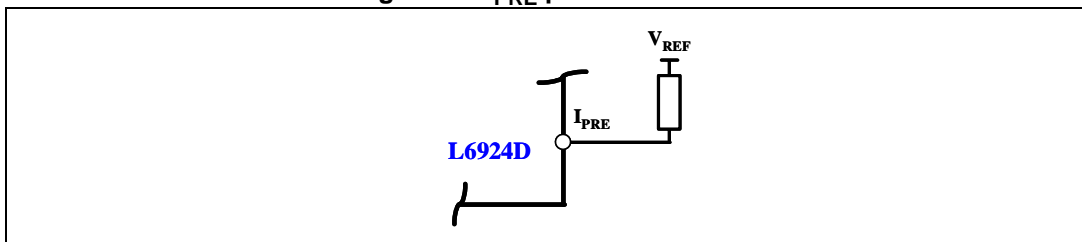

7.3 Pre-charge voltage

If the V_{PRE} pin is floating, a default value of V_{PRETH} is set, equal to 2.8 V ($V_{PRETHDefault}$). Otherwise, the device offers the possibility to program this value, with a resistor connected

between the V_{PRE} pin and GND (see [Figure 12](#)). In this case, the R_{VPRE} is given by the equation 8:

Equation 8

$$R_{VPRE} = R_{PRG} \times \left(\frac{V_{PRETH}}{V_{PRETH_{default}}} \right)$$

Figure 12. V_{PRE} pin connection

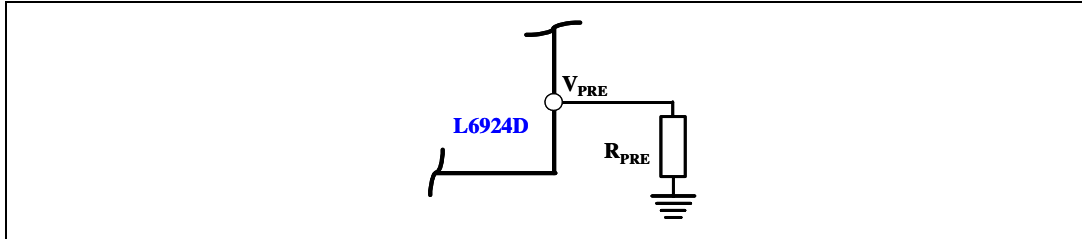

Where R_{VPRE} is the resistor between V_{PRE} and GND, and R_{PRG} is the resistor used to set the charge current (see [Section 7.4: Fast charge current](#)), and V_{PRETH} is the selected threshold.

A safety timer is also present. If the battery voltage doesn't rise over V_{PRETH} , before this time is expired, a fault is given (see [Section 7.8: Maximum charging time](#)). If at the beginning of the charge process, the battery voltage is higher than the V_{PRETH} , the Pre-Charge phase is skipped.

7.4 Fast charge current

When the battery voltage reaches the Pre-charge voltage threshold (V_{PRETH}), the L6924D starts the Fast-charge Phase. In this phase, the device charges the battery with a constant current, I_{CHG} , programmable by an external resistor that sets the charge current with an accuracy of 7% [Figure 13](#). The equation used to select the R_{PRG} as follows:

Equation 9

$$R_{PRG} = V_{BG} \times \left(\frac{K_{PRG}}{I_{CHG}} \right)$$

Figure 13. I_{PRG} pin connection

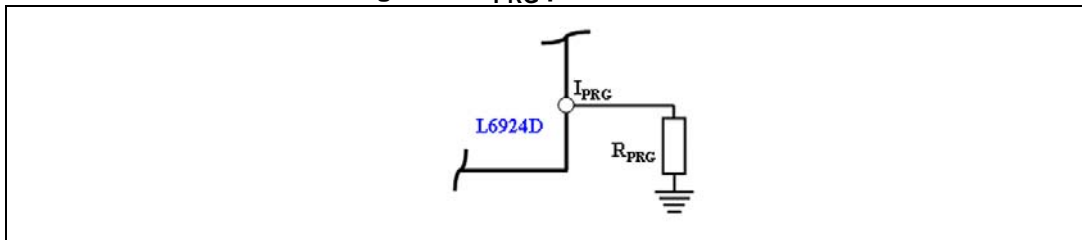

Where K_{PRG} is a constant, equal to 9500.

During this phase, the battery voltage increases until it reaches the programmed output voltage. A safety timer is also present. If this time expires, a fault is given ([Section 7.8: Maximum charging time](#)).

7.5 End-of-charge current

When the charge voltage approaches the selected value (4.1 V or 4.2 V), the voltage regulation phase takes place. The charge current starts to decrease until it goes lower than a programmable end value, I_{ENDTH} , depending on an external resistor connected between the I_{END} pin and GND (see [Figure 14](#)). The equation that describes this relation as follows:

Equation 10

$$R_{END} = V_{MIN} \times \left(\frac{K_{END}}{I_{ENDTH}} \right)$$

Figure 14. I_{END} pin connection

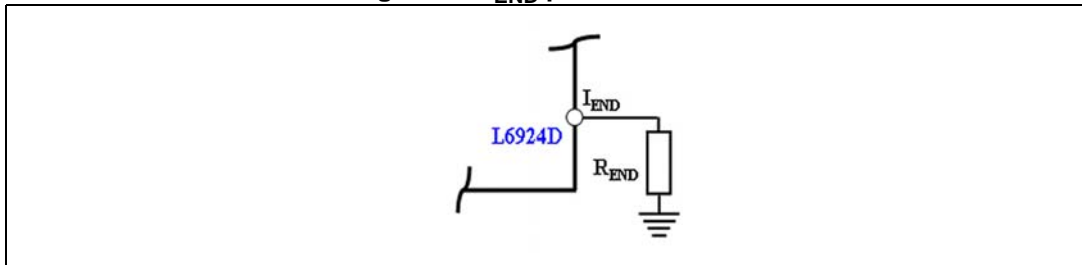

Where K_{END} is 1050; and V_{MIN} is 50 mV.

Typically, this current level is used to terminate the charge process. However, it is also possible to disable the charge termination process based on this current level ([Chapter 7.9 on page 23](#)).

This pin is also used to monitor the charge current, because the current injected in R_{END} is proportional to I_{CHG} . The voltage across R_{END} can be used by a microcontroller to check the charge status like a gas gauge.

7.6 Recharge flow chart

Figure 15. Recharge flow chart

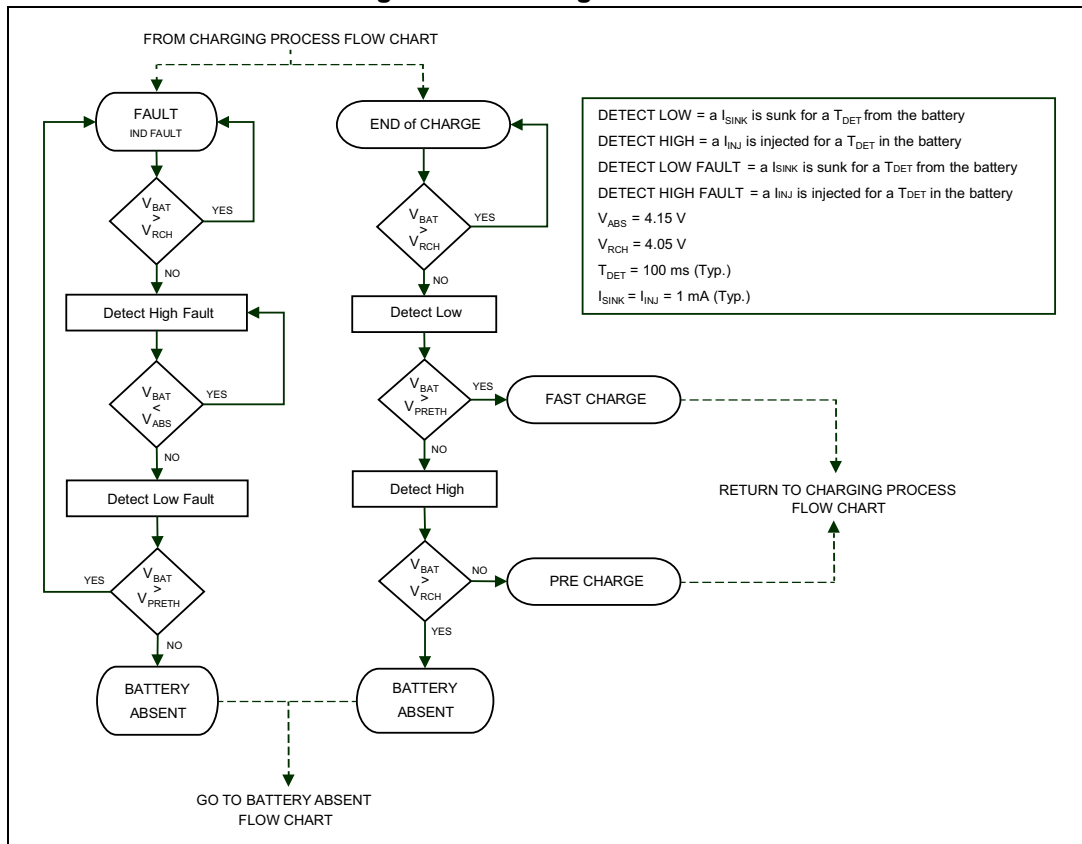

7.7 Recharge threshold

When, from an end-of-charge condition, the battery voltage goes lower than the recharging threshold (V_{RCH}), the device goes back in charging state. The value of the recharge threshold is $V_{OPRG} - 150\text{ mV}$.

7.8 Maximum charging time

To avoid the charging of a dead battery for a long time, the L6924D has the possibility to set a maximum charging time starting from the beginning of the fast-charge phase. This timer can be set with a capacitor, connected between the T_{PRG} pin and GND. The C_{TPRG} is the external capacitor (in nF) and is given by the following equation:

Equation 11

$$C_{TPRG} = \left(\frac{\frac{T_{MAXCH}}{K_T} \times \frac{V_{BG}}{R_{PRG}}}{V_{REF}} \right) \times 10^9$$

Note: The maximum recommended C_{TPRG} value must be less than 50 nF.

Figure 16. T_{PRG} pin connection

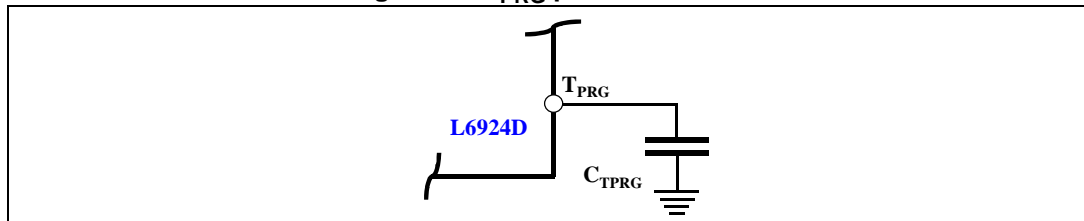

Where,

$$V_{REF} = 1.8V,$$

$$K_T = 279 \times 10^5,$$

$$V_{BG} = 1.23V, \text{ and}$$

T_{MAXCH} is the charging time given in seconds.

If the battery does not reach the end-of-charge condition before the timer expires, a fault is issued.

Also during the pre-charge phase there is a safety timer, given by:

Equation 12

$$T_{MAXPRECH} = \frac{1}{8} \times T_{MAXCH}$$

If this timer expires and the battery voltage is still lower than V_{PRETH}, a fault signal is generated, and the charge process is terminated.

7.9 Termination modes

Figure 17. Charge termination flow chart

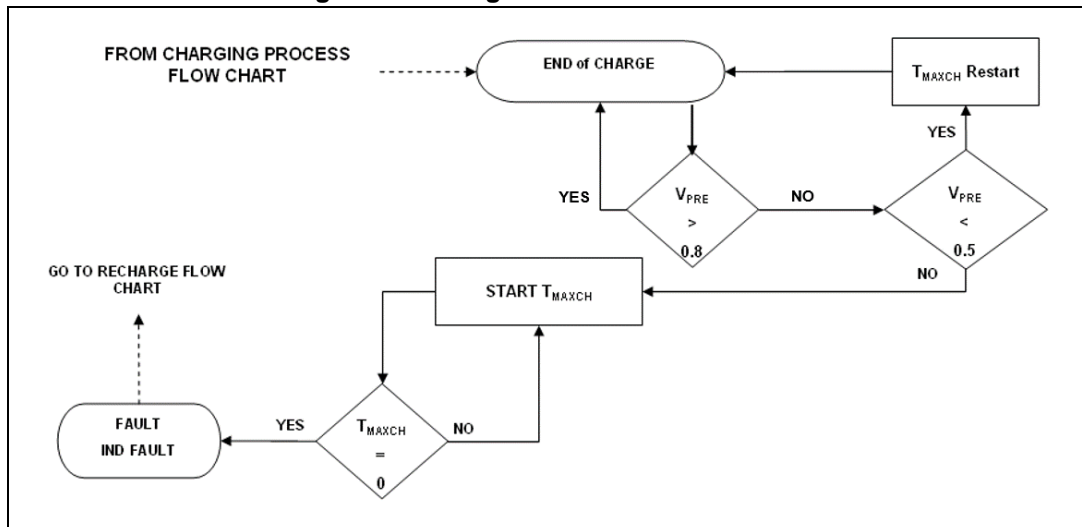

As shown in [Figure 14](#), it is possible to set an end of charge current I_{ENDTH} connecting a resistor between the I_{END} pin and GND. When the charge current goes down to this value, after a de-glitch time, the status pins notify that the charge process is complete. This de-glitch time is expressed as:

Equation 13

$$T_{DEGLITCH} = \frac{T_{MAXCH}}{220}$$

However, the termination of the charger process depends on the status of the V_{PRE} pin:

- If the voltage at the V_{PRE} pin is higher than 0.8 V, the charge process is actually terminated when the charge current reaches I_{ENDTH} .
- If the voltage at V_{PRE} pin goes lower than 0.8 V, the charge process does not terminate, and the charge current can go lower than I_{ENDTH} . The status pins notify the end-of-charge as a fault condition, but the device continues the charge. When the T_{MAXCH} is elapsed, the charge process ends, and a fault condition is issued.
- If the voltage on V_{PRE} pin is lower than 0.8 V during the Pre-charge Phase, the device sets the $V_{PRETHDefault}$ automatically.
- If the voltage at the V_{PRE} pin goes lower than 0.5 V (edge sensitive), the timer is reset, both in pre-charge and in fast-charge phase.

8 Application information: monitoring and protection

The L6924D uses a VFQFPN 3 mm x 3 mm 16-pin package with an exposed pad that allows the user to have a compact application and good thermal behavior at the same time. The L6924D has a low thermal resistance because of the exposed pad (approximately 75°C/W, depending on the board characteristics). Moreover, a built-in thermal protection feature prevents the L6924D from having thermal issues typically present in a linear charger.

Thermal control is implemented with a thermal loop that reduces the charge current automatically when the junction temperature reaches approximately 120 °C. This avoids further temperature rise and keeps the junction temperature constant. This simplifies the thermal design of the application as well as protects the device against over-temperature damage.

The [Figure 18](#) shows how the thermal loop acts (with the dotted lines), when the junction temperature reaches 120°C.

Figure 18. Power dissipation both linear and quasi pulse mode with thermal loop

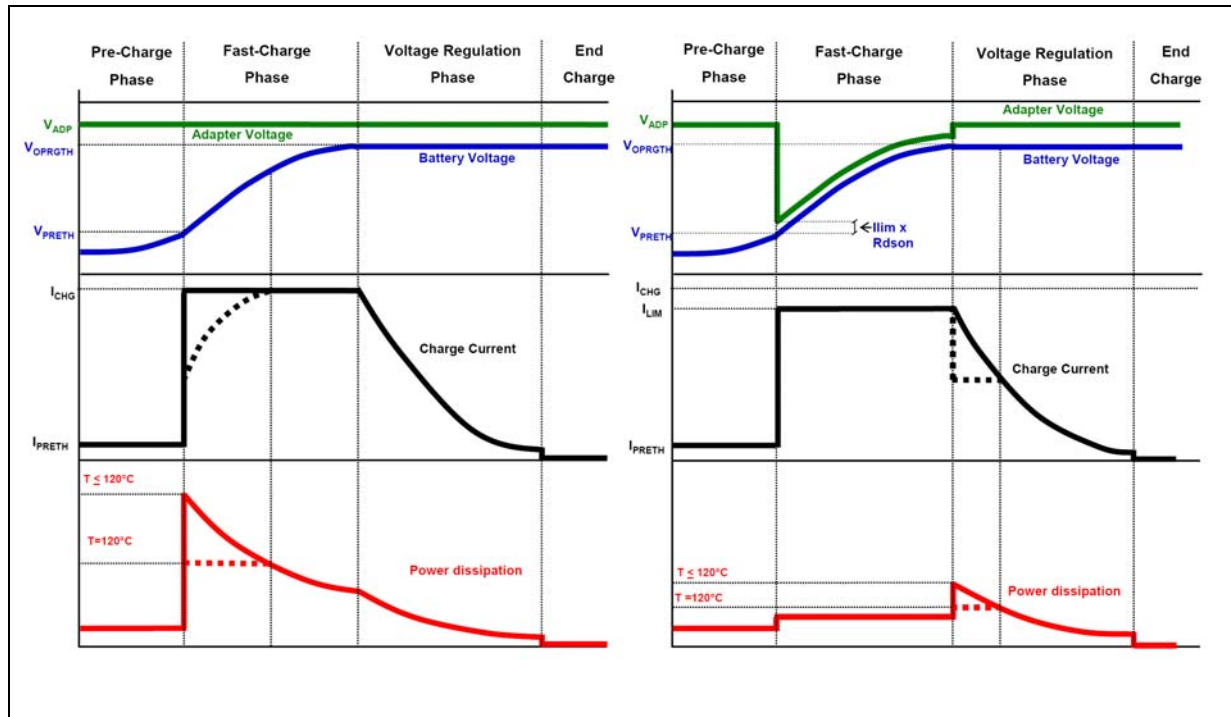

8.1 NTC thermistor

The device allows designers to monitor the battery temperature by measuring the voltage across an NTC or PTC resistor. Li-Ion batteries have a narrow range of operating temperature, usually from 0°C to 50 °C. This window is programmable by an external divider which is comprised of an NTC thermistor connected to GND and a resistor connected to V_{REF} . When the voltage on the TH pin exceeds the minimum or maximum voltage threshold

(internal window comparator), the device stops the charge process, and indicates a fault condition through the status pin.

When the voltage (and thus, the temperature), returns to the window range, the device re-starts the charging process. Moreover, there is a hysteresis for both the upper and lower thresholds, as shown in [Figure 20](#).

Figure 19. Battery temperature control flow chart

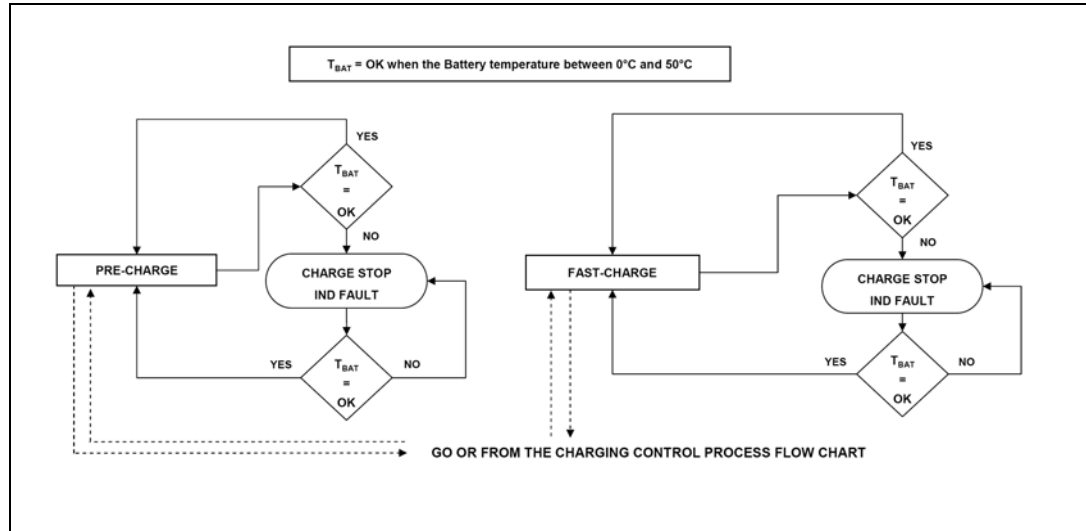

Note: $T_{BAT} = OK$ when the battery temperature between $0^{\circ}C$ and $50^{\circ}C$

Figure 20. Voltage window with hysteresis on TH

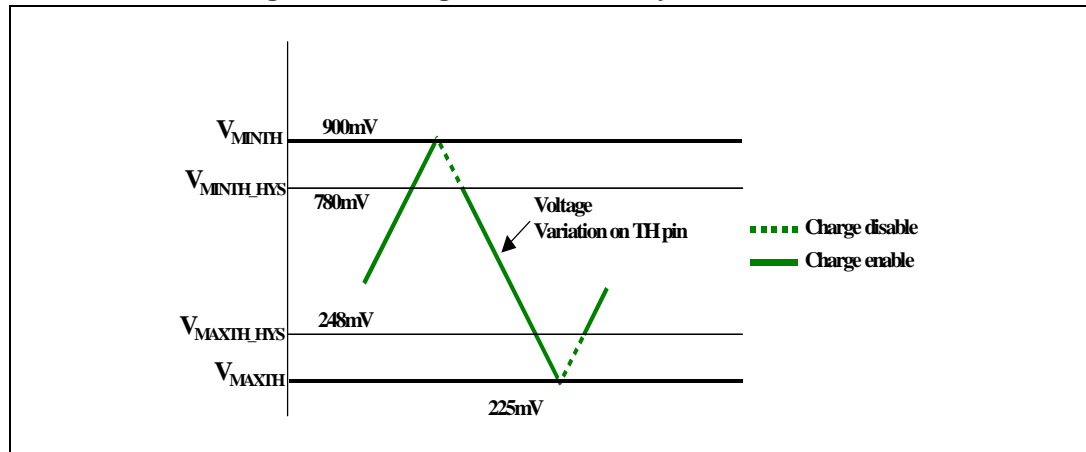
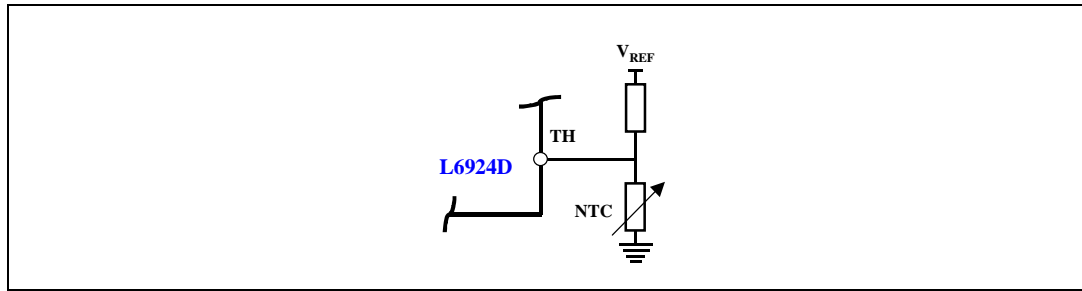

Figure 21. Pin connection



When the TH pin voltage rises and exceeds the $V_{MINTH} = 50\%$ of V_{REF} (900 mV typ), the L6924D stops the charge, and indicates a fault by the status pins. The device re-starts to charge the battery, only when the voltage at the TH pin goes under $V_{MINTH_HYS} = 780$ mV (typ).

For what concerns the high temperature limit, when the TH pin voltage falls under the $V_{MAXTH} = 12.5\%$ of V_{REF} (225 mV Typ.), the L6924D stops the charge until the TH pin voltage rises to the $V_{MAXTH_HYS} = 248$ mV (Typ.).

When the battery is at the low temperature limit, the TH pin voltage is 900 mV. The correct resistance ratio to set the low temperature limit at 0°C can be found with the following equation:

Equation 14

$$V_{MINTH} = V_{REF} \times \frac{R_{NTC0^{\circ}C}}{R_{UP} + R_{NTC0^{\circ}C}}$$

Where R_{UP} is the pull-up resistor, V_{REF} is equal to 1.8 V, and $R_{NTC0^{\circ}C}$ is the value of the NTC at 0°C. Since at the low temperature limit $V_{MINTH} = 900$ mV:

Equation 15

$$0.9 = 1.8 \times \frac{R_{NTC0^{\circ}C}}{R_{UP} + R_{NTC0^{\circ}C}}$$

It follows that:

Equation 16

$$R_{NTC0^{\circ}C} = R_{UP}$$

Similarly, when the battery is at the high temperature limit, the TH pin voltage is 225 mV. The correct resistance ratio to set the high temperature limit at 50°C can be found with the following equation:

Equation 17

$$V_{MAXTH} = V_{REF} \times \frac{R_{NTC50^{\circ}C}}{R_{UP} + R_{NTC50^{\circ}C}}$$

Where $R_{NTC50^{\circ}C}$ is the value of the NTC at 50°C. Considering $V_{MAXTH} = 225$ mV it follows that:

Equation 18

$$0.225 = 1.8 \times \frac{R_{NTC50^{\circ}C}}{R_{UP} + R_{NTC50^{\circ}C}}$$

Consequently:

Equation 19

$$R_{NTC50^{\circ}C} = \frac{R_{UP}}{7}$$

Based on [Equation 16](#): and [Equation 19](#): , it derives that:

Equation 20

$$\frac{R_{NTC0^{\circ}C}}{R_{NTC50^{\circ}C}} = 7$$

The temperature hysteresis can be estimated by the equation:

Equation 21

$$T_{HYS} = \frac{V_{TH} - V_{TH_HYS}}{V_{TH} \times NTC_T}$$

Where V_{TH} is the pin voltage threshold on the rising edge, V_{TH_HYS} is the pin voltage threshold on the falling edge, and NTC_T (-%/°C) is the negative temperature coefficient of the NTC at temperature (T) expressed in % resistance change per °C. For NTC_T values, see the characteristics of the NTC manufacturers (e.g. the 2322615 series by VISHAY). At the low temperature, the hysteresis is approximately:

Equation 22

$$T_{HYS0^{\circ}C} = \frac{900mV - 780mV}{900mV \times NTC0^{\circ}C}$$

Obviously at the high temperature hysteresis is:

Equation 23

$$T_{HYS50^{\circ}C} = \frac{225mV - 248mV}{225mV \times NTC50^{\circ}C}$$

Considering typical values for $NTC0^{\circ}C$ and $NTC50^{\circ}C$, the hysteresis is:

Equation 24

$$T_{HYS0^{\circ}C} = \frac{900mV - 780mV}{900mV \times 0.051} \cong 2.5^{\circ}C$$

And:

Equation 25

$$T_{HYS50^{\circ}C} = \frac{225mV - 248mV}{225mV \times 0.039} \cong -2.5^{\circ}C$$

If a PTC connected to GND is used, the selection is the same as above, the only difference is when the battery temperature increases, the voltage on the TH pin increases, and vice versa. For applications that do not need a monitor of the battery temperature, the NTC can be replaced with a simple resistor whose value is one half of the pull-up resistor R_{UP} .

In this case, the voltage at the TH pin is always inside the voltage window, and the charge is always enabled.

8.2 Battery absence detection

This feature provides a battery absent detection scheme to detect the removal or the insertion of the battery. If the battery is removed, the charge current falls below the I_{ENDTH} . At the end of the de-glitch time, a detection current I_{DETECT} , equal to 1 mA, is sunk from the output for a time of T_{DETECT} . The device checks the voltage at the output. If it is below the V_{PRETH} , a current equal to I_{DETECT} is injected in the output capacitor for a T_{DETECT} , and it is checked to see if the voltage on the output goes higher than V_{ABS} (the value is $V_{OPRGTH}-50$ mV). If the battery voltage changes from V_{PRETH} to V_{ABS} and vice versa in a T_{DETECT} time, it means that no battery is connected to the charger. The T_{DETECT} is expressed by:

Equation 26

$$T_{DETECT} = \frac{T_{MAXCH}}{54 \times 10^3}$$

Figure 22. Battery absent detection flow chart

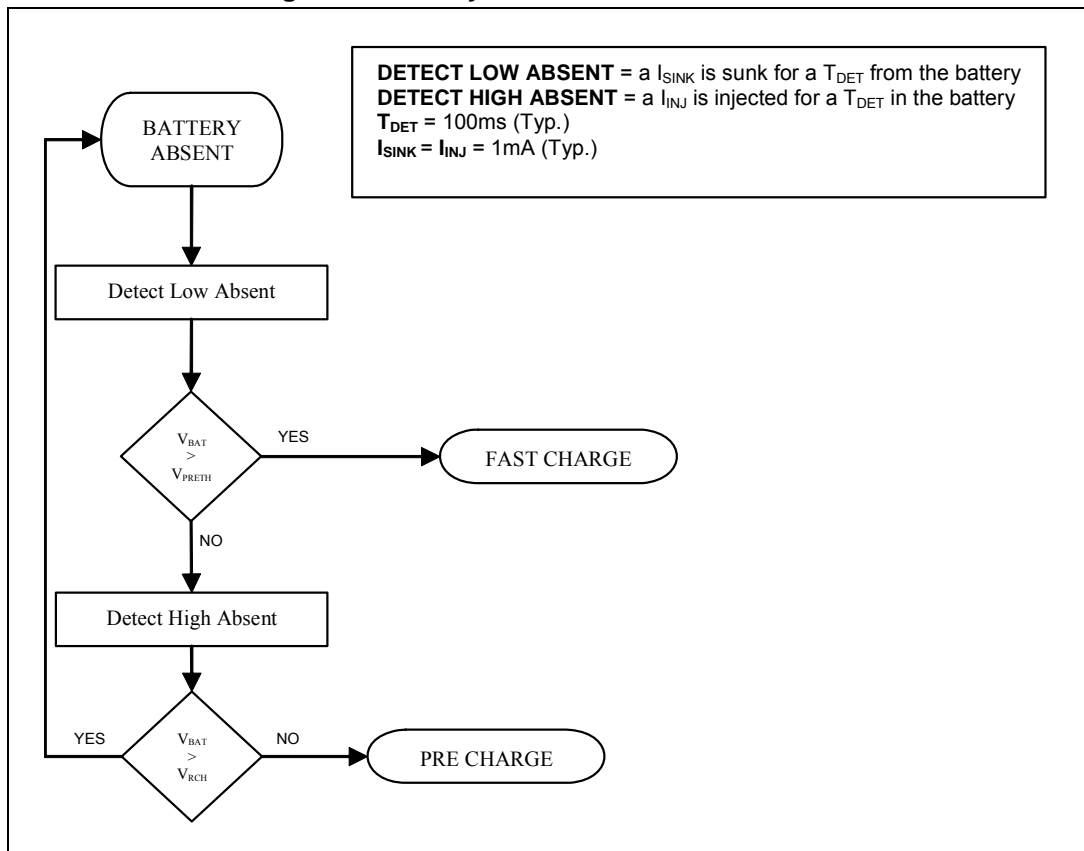

8.3 Status pins

To indicate various charger status conditions, there are two open-collector output pins, ST1 and ST2. These status pins can be used either to drive status LEDs, connected to an external power source, by a resistor, or to communicate to a host processor. These pins must never be connected to the V_{IN} when it exceeds their absolute value (6 V).

Figure 23. ST1 and ST2 connection with LEDs or microcontroller

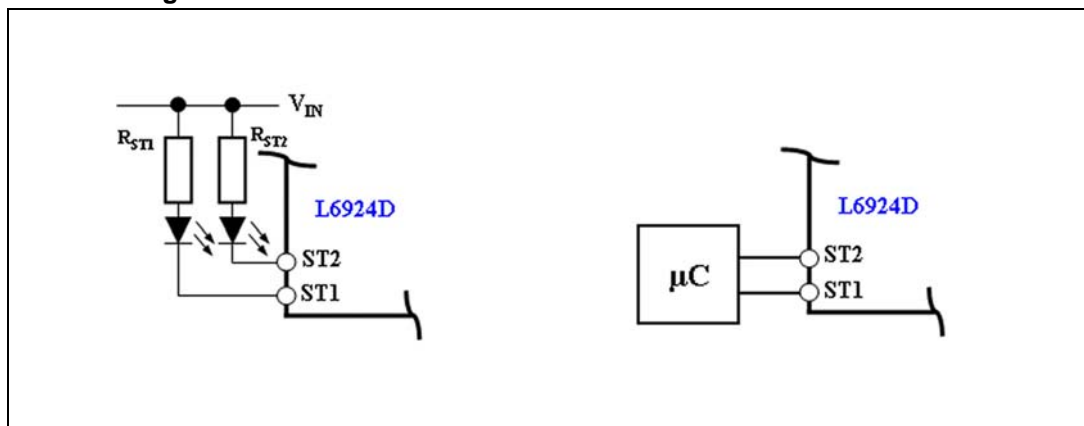

Table 6. Status LEDs indications

Charge condition	Description	ST1	ST2
Charge in progress	When the device is in pre-charge or fast-charge status	ON	OFF
Charge done	When the charging current goes lower than the I_{ENDTH}	OFF	ON
Stand by mode	When the input voltage goes under $V_{BAT}-50\text{ mV}$	OFF	OFF
Bad battery temperature	When the voltage on the TH pin is out of the programmable window, in accordance with the NTC or PTC thermistor	ON	ON
Battery absent	When the battery pack is removed	ON	ON
Over time	When T_{MAXCH} or $T_{MAXPRECH}$ is expired	ON	ON

8.4 Shutdown

The L6924D has a shutdown pin (SD) that allows enabling or disabling the device.

If the SD pin voltage is below 0.4 V (e.g. pin connected to GND), the device is enabled, whereas if the SD pin voltage exceeds 2 V (e.g. the shutdown pin is left floating) the device is disabled.

When the device enters the shutdown mode, the current consumption is reduced to 60 μA typ. In this condition, V_{REF} is turned off.

The [Figure 24](#) clarifies the SD pin behavior.

Figure 24. Shutdown

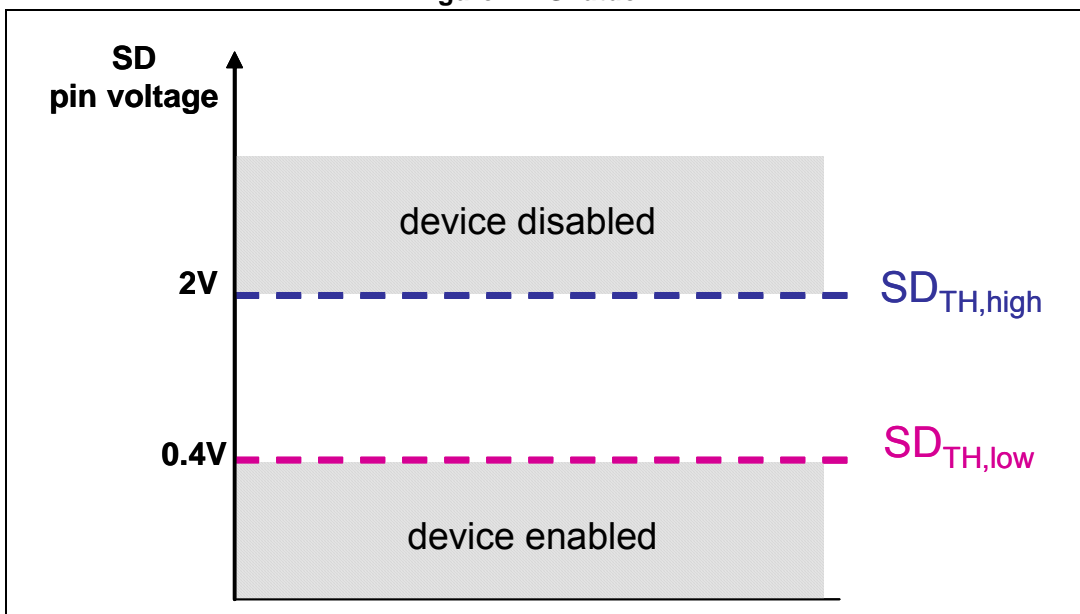

9 Additional application information

9.1 Selecting the input capacitor

In most applications, a 1 μF ceramic capacitor, placed close to the V_{IN} and V_{INSN} pins can be used to filter the high frequency noise.

9.2 Selecting the output capacitor

Typically, 1 μF ceramic capacitor placed close to the V_{OUT} and V_{OUTSN} pin is enough to keep voltage control loop stable. This ensures proper operation of battery absent detection in removable battery pack applications.

9.3 Battery floating voltage setup

The L6924D has been evaluated with the following application schematic.

Figure 25. L6924D application schematic

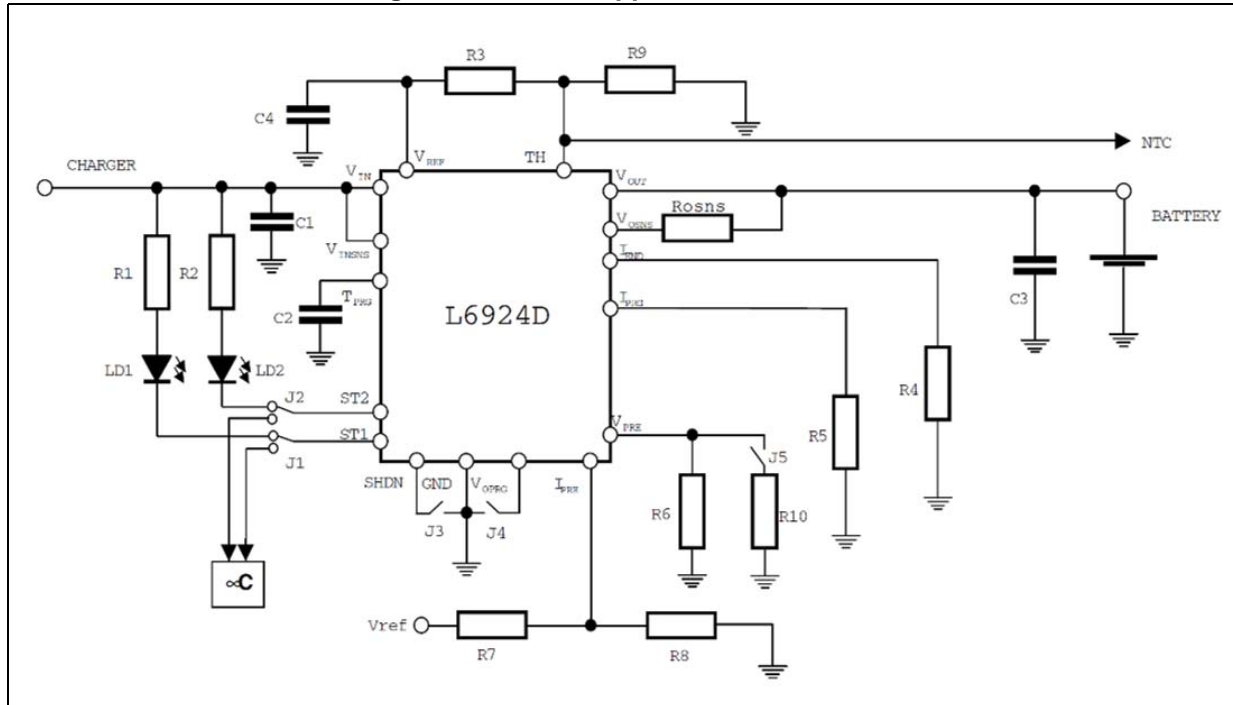

Table 7. External component values for the L6924D

Name	Value	Description	Note
R1, R2	1 kΩ	Pull-up resistor	
C1	1 μF	Input supply voltage capacitor	
C2	10 nF	Maximum charging time capacitor	
Rosns	7500 Ω	V _{FLOAT} programming resistor	
C3	1 μF	Output battery capacitor	
R3	1 kΩ	NTC supply resistor	
R9	470 Ω	NTC tuning parallel resistor	
C4	1 μF	V _{REF} filter capacitor	
R6	Not populated	Pre-charge voltage programming resistor	V _{PRE} = 2.8 V as default value
R10	Not populated	Pre-charge voltage programming resistor	
R5	48.6 kΩ	Fast-charge current programming resistor	I _{FAST} = 240 mA
R4	2.2 kΩ	Set standard I _{END} = 10% I _{FAST}	I _{END} ~ 24 mA
R7	Not populated	Pre-charge current default 10%	I _{PRE} ~ 24 mA as default value
R8	Not populated	Pre-charge current default 10%	

9.3.1 Battery floating voltage: V_{FLOAT}

The battery floating voltage can be set to a value higher than 4.2 V by using the following formula:

$$V_{\text{FLOAT}} = 4.2 \text{ V} + R_{\text{osns}} * 19.5 \text{ } \mu\text{A} = 4.346 \text{ V}$$

As an example, with $R_{\text{osns}} = 7.5 \text{ k}\Omega$ the battery floating voltage (V_{FLOAT}) is set to be $V_{\text{FLOAT}} = 4.346 \text{ V}$.

Figure 26. V_{FLOAT} vs. R_{osns}

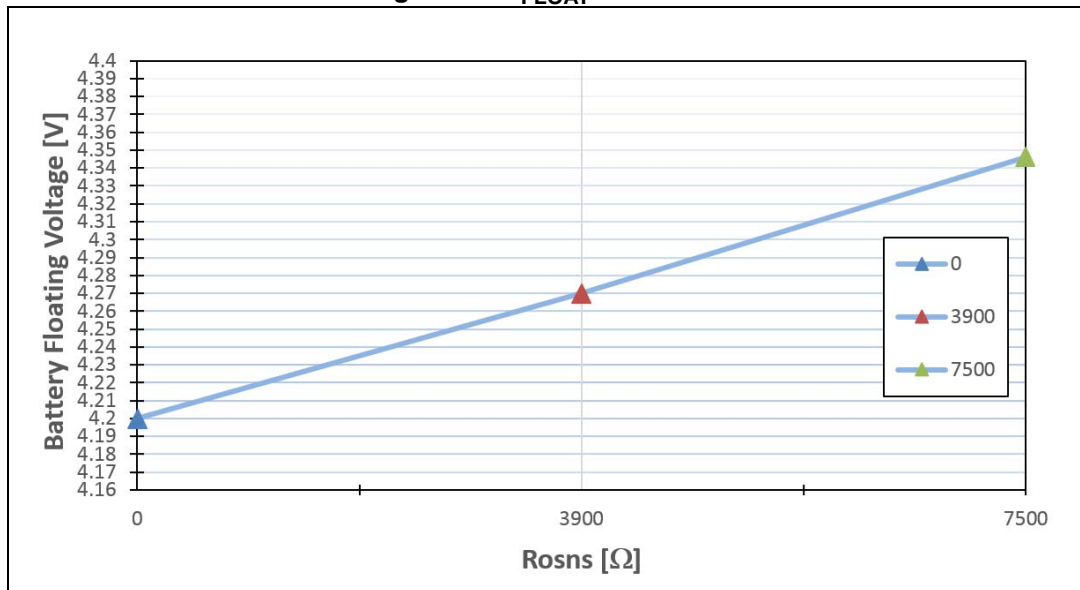

The L6924D works with the selected external components. The test results confirm that their behavior is in line with the design.

9.4 Layout guidelines and demonstration board description

The thermal loop keeps the device at a constant temperature of approximately 120°C which in turn, reduces I_{CHG} . However, in order to maximize the current capability, it is important to ensure a good thermal path. Therefore, the exposed pad must be properly soldered to the board and connected to the other layer through thermal vias. The recommended copper thickness of the layers is 70 μm or more.

The exposed pad must be electrically connected to GND. [Figure 27](#) shows the thermal image of the board with the power dissipation of 1 W. In this instance, the temperature of the case is 89°C, but the junction temperature of the device is given by the following equation:

Equation 27

$$T_J = R_{\text{THJ-A}} \times P_{\text{DISS}} + T_{\text{AMB}}$$

Where the $R_{\text{THJ-A}}$ of the device mounted on board is 75 °C/W, the power dissipated is 1 W, and the ambient temperature is 25 °C.

In this case the junction temperature is:

Equation 28

$$T_j = 75 \times 1 + 25 = 100^\circ\text{C}$$

Figure 27. Thermal image of the demonstration board

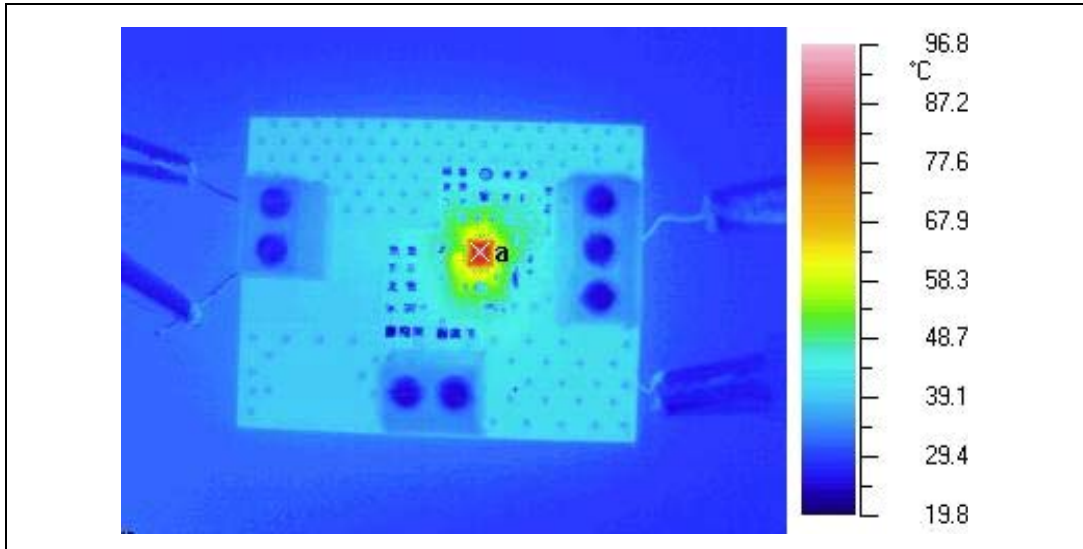

The V_{OSNS} pin can be used as a remote sense; it should be therefore connected as closely as possible to the battery. The demonstration board layout and schematic are shown in [Figure 28](#), [Figure 29](#) and [Figure 30](#).

Figure 28. Demonstration board layout, top side

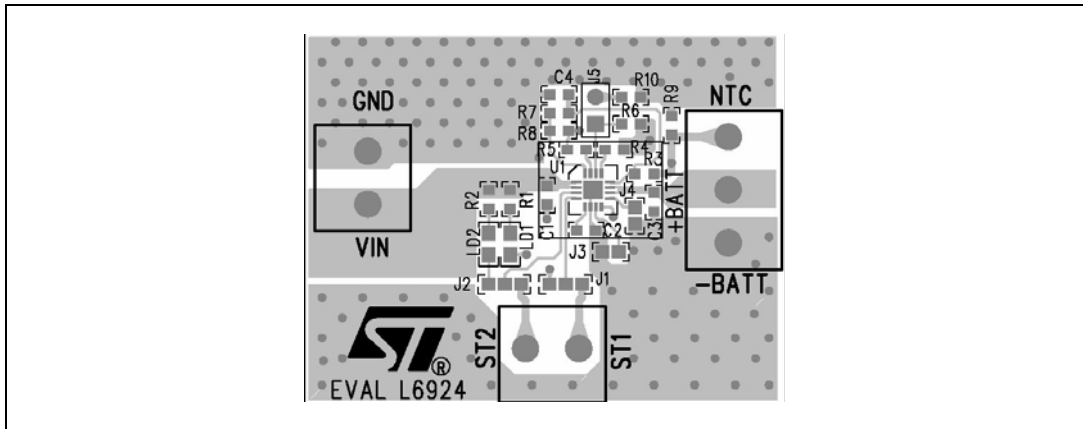

Table 8. Demonstration board components description

Name	Value	Description
R1	1k	Pull up resistor. To be used when the ST1 is connected to a LED.
R2	1k	Pull up resistor. To be used when the ST1 is connected to a LED.
R3	1k	Pull up resistor. Connected between V_{REF} and TH pin.
R4	3k3	End of charge current resistor. Used to set the termination current and, as a "Gas Gauge" when measuring the voltage across on it.
R5	24k	Fast-charge current resistor. Used to set the charging current.
R6	N.M.	V_{PRETH} resistor. Used to set programmable pre-charge voltage threshold. If not mounted, the $V_{PRETHDefault}$, equal to 2.8V, is set.
R7	N.M.	I_{PRETH} resistor. Used to set the programmable pre-charge current threshold below the default one. If not mounted, the $I_{PRETHDefault}$ is set.
R8	68k	I_{PRETH} resistor. Used to set the programmable pre-charge current threshold above the default one. If not mounted, the $I_{PRETHDefault}$ is set.
R9	470R	If a NTC is not used, a half value of R3 must be mounted to keep the TH voltage in the correct window.
R10	N.M.	It has the same function of R6. Moreover, if it is replaced with a short-circuit, when J5 is closed, the timer is reset (falling edge).
C1	1 μ F	Input capacitor.
C2	10nF	T_{MAX} capacitor. Used to set the maximum charging time.
C3	4.7 μ F	Output capacitor.
C4	1nF	V_{REF} filter capacitor.
LD1	GREEN	ST1 LED.
LD2	RED	ST2 LED.
J1		ST1 jumper. Using to select the LED or the external μ C.
J2		ST2 jumper. Using to select the LED or the external μ C.
J3		SD jumper. If open, the device is in shutdown mode; when closed, the device starts to work.
J4		V_{OPRG} jumper. If closed, the 4.2V output voltage is set; if open, the 4.1V is set.
J5		V_{PRE} jumper. If closed with R10 in short-circuit with GND, resets the timer.

10 Application ideas

10.1 USB battery charger

With a voltage range between 4.75 V and 5.25 V, and a maximum current up to 500 mA, the USB power bus is an ideal source for charging a single-cell Li-Ion battery. Since it is not possible to rely on the USB current limit to charge the battery, a linear approach must be adopted. Therefore, it is only necessary to set the I_{CHG} with a maximum value lower than 500 mA, and the device will charge the battery in Linear mode.

Figure 31 shows an example of USB charger application schematic.

Figure 31. USB charger application

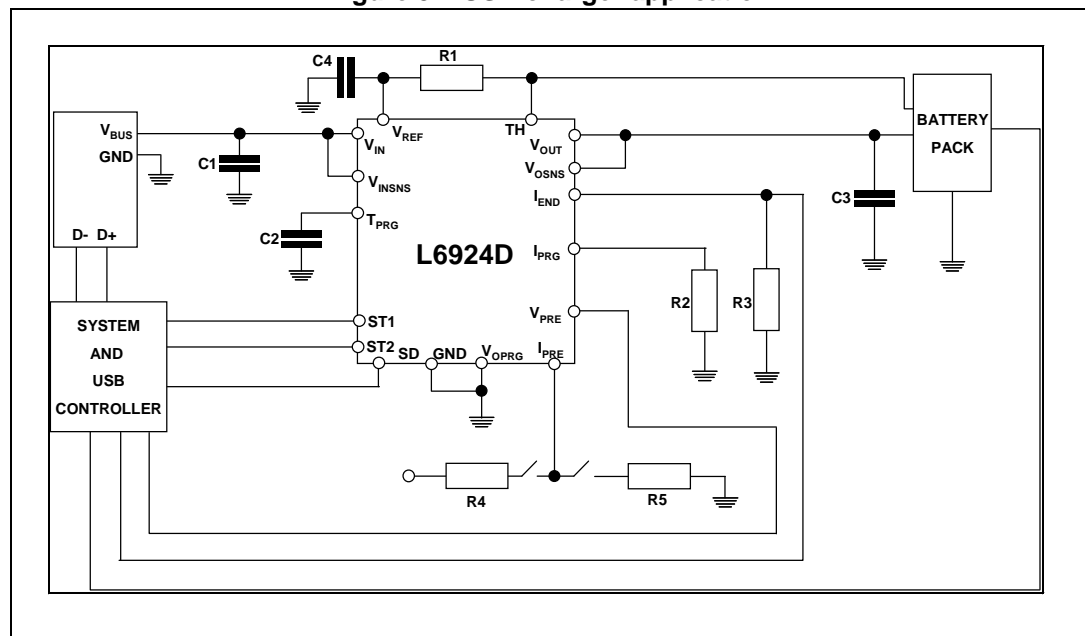

11 Package information

In order to meet environmental requirements, ST offers these devices in different grades of ECOPACK[®] packages, depending on their level of environmental compliance. ECOPACK[®] specifications, grade definitions and product status are available at: www.st.com. ECOPACK[®] is an ST trademark.

12 Revision history

Table 10. Document revision history

Date	Revision	Changes
16-Dec-2005	1	First draft
20-Dec-2005	2	Package dimensions updated
10-Jan-2006	3	Few updates
14-Feb-2006	4	Part number updated
03-Jul-2006	5	Updates to equation in page 22, updated block diagram Figure 4
07-Sep-2006	6	Added Note: on page 22, updated value CTPRG page 8
29-Jun-2007	7	Updated capacitor values C2, C3 in Table 8 on page 36
05-Jul-2010	8	Updated Table 5 on page 8 and Section 8.4 on page 30
22-Sep-2010	9	Updated Table 9 and Figure 32 on page 39. Minor changes
25-Sep-2017	10	Updated Applications and Table 1: Device summary Updated power dissipation in Table 4: Thermal data Added Section 9.3: Battery floating voltage setup
28-Jan-2019	11	Updated Figure 15: Recharge flow chart and Figure 17: Charge termination flow chart

IMPORTANT NOTICE – PLEASE READ CAREFULLY

STMicroelectronics NV and its subsidiaries (“ST”) reserve the right to make changes, corrections, enhancements, modifications, and improvements to ST products and/or to this document at any time without notice. Purchasers should obtain the latest relevant information on ST products before placing orders. ST products are sold pursuant to ST’s terms and conditions of sale in place at the time of order acknowledgement.

Purchasers are solely responsible for the choice, selection, and use of ST products and ST assumes no liability for application assistance or the design of Purchasers’ products.

No license, express or implied, to any intellectual property right is granted by ST herein.

Resale of ST products with provisions different from the information set forth herein shall void any warranty granted by ST for such product.

ST and the ST logo are trademarks of ST. All other product or service names are the property of their respective owners.

Information in this document supersedes and replaces information previously supplied in any prior versions of this document.

© 2019 STMicroelectronics – All rights reserved

Looking for pricing, stock, or lifecycle information?

Click below to explore more details on WIN SOURCE:

-  [View L6924D013TR](#) on WIN SOURCE
-  [STMicroelectronics](#) Information

Optimize Your Supply Chain with WIN SOURCE Solutions

-  Global Sourcing Solution
-  Obsolete Management
-  Cost Control Management
-  Shortage Management
-  Alternative Solution
-  Excess Inventory Management