



**THE DATASHEET OF
L6590ED013TR**





FULLY INTEGRATED POWER SUPPLY

- WIDE-RANGE MAINS OPERATION
- "ON-CHIP" 700V V(BR)DSS POWER MOS
- 65 kHz INTERNAL OSCILLATOR
- 2.5V \pm 2% INTERNAL REFERENCE
- STANDBY MODE FOR HIGH EFFICIENCY AT LIGHT LOAD
- OVERCURRENT AND LATCHED OVERVOLTAGE PROTECTION
- NON DISSIPATIVE BUILT-IN START-UP CIRCUIT
- THERMAL SHUTDOWN WITH HYSTERESIS
- BROWNOUT PROTECTION (SMD PACKAGE ONLY)

MAIN APPLICATIONS

- WALL PLUG POWER SUPPLIES UP TO 15 W
- AC-DC ADAPTERS
- AUXILIARY POWER SUPPLIES FOR:
 - CRT AND LCD MONITOR (BLUE ANGEL)
 - DESKTOP PC/SERVER
 - FAX, TV, LASER PRINTER

TYPICAL APPLICATION CIRCUIT

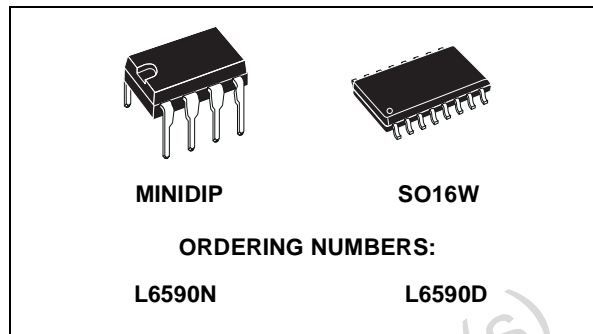
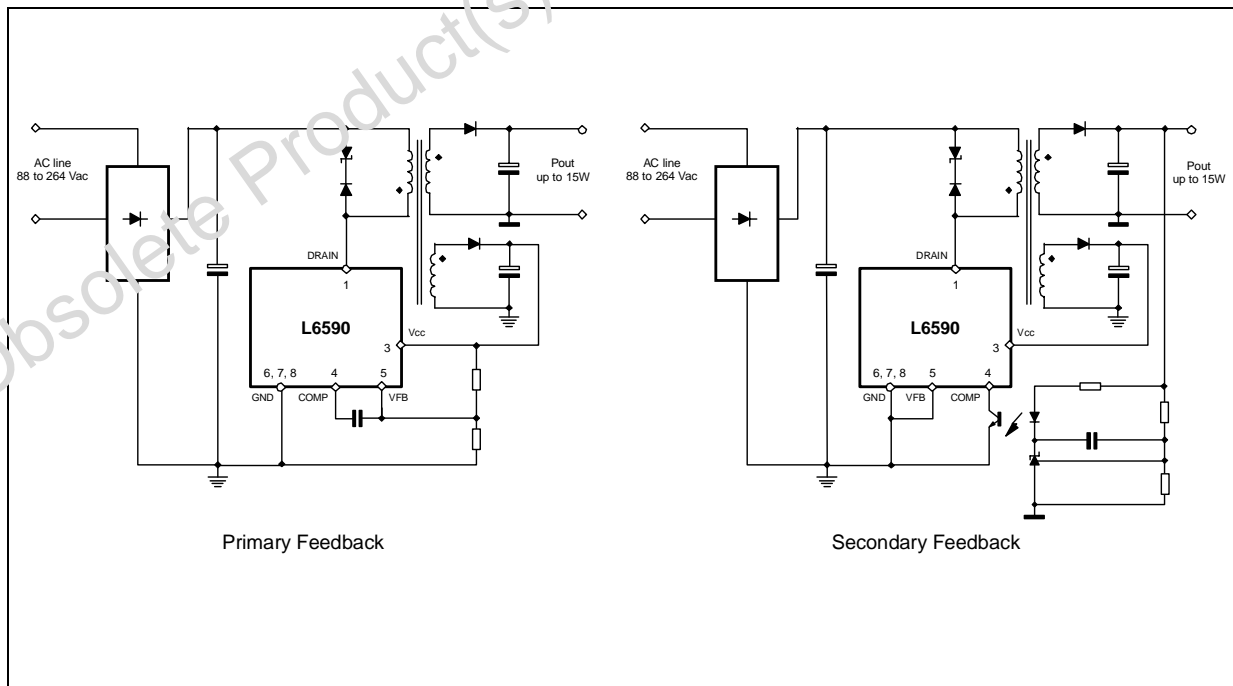

- HOME APPLIANCES/LIGHTING
- LINE CARD, DC-DC CONVERTERS

DESCRIPTION

The L6590 is a monolithic switching regulator designed in BCD OFF-LINE technology, able to operate with wide range input voltage and to deliver up to 15W output power. The internal power switch is a lateral power MOSFET with a typical $R_{DS(on)}$ of 13 Ω and a $V_{(BR)DSS}$ of 700V minimum.

L6590

DESCRIPTION (continued)

The MOSFET is source-grounded, thus it is possible to build flyback, boost and forward converters.

The device can work with secondary feedback and a $2.5V \pm 2\%$ internal reference, in addition to a high gain error amplifier, makes possible also the use in applications either with primary feedback or not isolated.

The internal fixed oscillator frequency and the integrated non dissipative start-up generator minimize the external component count and power consumption.

The device is equipped with a standby function that automatically reduces the oscillator frequency from 65 to 22 kHz under light load conditions to enhance

efficiency ($P_{in} < 1W @ P_{out} = 0.5W$ with wide range mains).

Internal protections like cycle-by-cycle current limiting, latched output overvoltage protection, mains undervoltage protection (SMD version only) and thermal shutdown generate a 'robust' design solution.

The IC uses a special leadframe with the ground pins (6, 7 and 8 in minidip, 9 to 16 in SO16W package) internally connected in order for heat to be easily removed from the silicon die. An heatsink can then be realized by simply making provision of few cm^2 of copper on the PCB. Furthermore, the pin(s) close to the high-voltage one are not connected to ease compliance with safety distances on the PCB.

BLOCK DIAGRAM

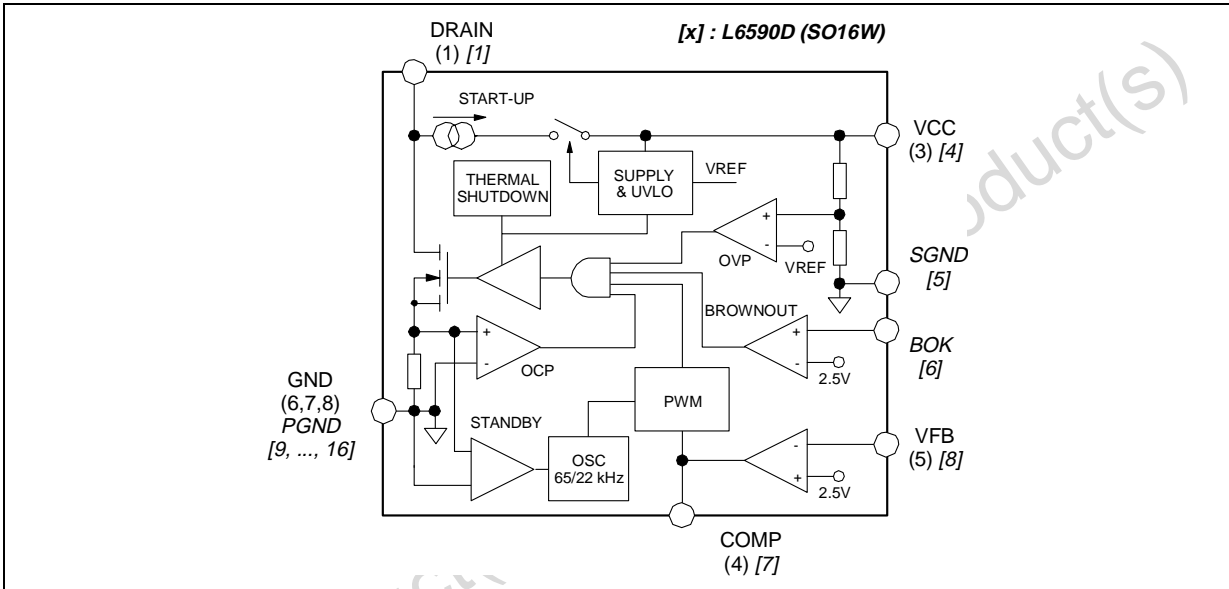

PIN CONNECTIONS (Top view)

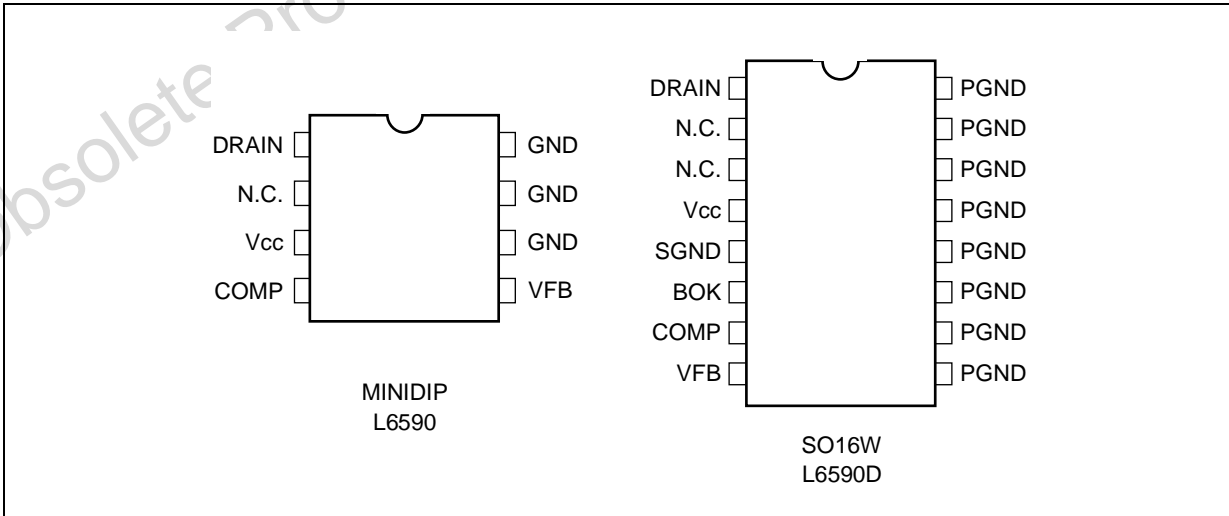

PIN FUNCTIONS

Pin#		Name	Description
L6590	L6590D		
1	1	DRAIN	Drain connection of the internal power MOSFET. The internal high voltage start-up generator sinks current from this pin.
2	2, 3	N.C.	Not internally connected. Provision for clearance on the PCB.
3	4	V _{CC}	Supply pin of the IC. An electrolytic capacitor is connected between this pin and ground. The internal start-up generator charges the capacitor until the voltage reaches the start-up threshold. The PWM is stopped if the voltage at the pin exceeds a certain value.
4	7	COMP	Output of the Error Amplifier. Used for control loop compensation or to directly control PWM with an optocoupler.
5	8	VFB	Inverting input of the Error Amplifier. The non-inverting one is internally connected to a 2.5V ± 2% reference. This pin can be grounded in some feedback schemes.
6 to 8	-	GND	Connection of both the source of the internal MOSFET and the return of the bias current of the IC. Pins connected to the metal frame to facilitate heat dissipation.
-	6	BOK	Brownout Protection. If the voltage applied to this pin is lower than 2.5V the PWM is disabled. This pin is typically used for sensing the input voltage of the converter through a resistor divider. If not used, the pin can be either left floating or connected to V _{CC} through a 15 kΩ resistor.
-	5	SGND	Current return for the bias current of the IC.
-	9 to 16	PGND	Connection of the source of the internal MOSFET. Pins connected to the metal frame to facilitate heat dissipation.

THERMAL DATA

Symbol	Parameter	Minidip	SO16W	Unit
R _{thj-amb}	Thermal Resistance Junction to ambient (*)	35 to 60	40 to 65	°C/W
R _{thj-pins}	Thermal Resistance Junction to pins	15	20	°C/W

(*) Value depending on PCB copper area and thickness.

ABSOLUTE MAXIMUM RATINGS

Symbol	Parameter	Value	Unit
V _{ds}	Drain Source Voltage	-0.3 to 700	V
I _d	Drain Current	0.7	A
V _{CC}	IC Supply Voltage	18	V
I _{clamp}	V _{CC} Zener Current	20	mA
	Error Amplifier Output Sink Current	3	mA
	Voltage on Feedback Input	5	V
	BOK pin Sink Current	1	mA
P _{tot}	Power Dissipation at T _{amb} < 50°C (Minidip and SO16W) 3 cm ² , 2 oz copper dissipating area on PCB	1.5	W
T _j	Operating Junction Temperature	-40 to 150	°C
T _{stg}	Storage Temperature	-40 to 150	°C

ELECTRICAL CHARACTERISTICS ($T_j = -25$ to 125°C , $V_{CC} = 10\text{V}$; unless otherwise specified)

Symbol	Parameter	Test Condition	Min.	Typ.	Max.	Unit
--------	-----------	----------------	------	------	------	------

POWER SECTION

$V_{(BR)DSS}$	Drain Source Voltage	$I_d < 200 \mu\text{A}$; $T_j = 25^\circ\text{C}$	700			V
I_{DSS}	Off state drain current	$V_{DS} = 560\text{V}$; $T_j = 125^\circ\text{C}$			200	μA
$R_{DS(on)}$	Drain-to-Source on resistance $R_{DS(on)}$ vs. T_j : see fig. 20	$I_d = 120\text{mA}$; $T_j = 25^\circ\text{C}$		13	16	Ω
		$I_d = 120\text{mA}$; $T_j = 125^\circ\text{C}$		23	28	

ERROR AMP SECTION

V_{FB}	Input Voltage	$T_j = 25^\circ\text{C}$	2.45	2.5	2.55	V
		$T_j = 125^\circ\text{C}$	2.4	2.5	2.6	
I_b	E/A Input Bias Current	$V_{FB} = 0$ to 2.5V		0.3	5	μA
A_{vol}	DC Gain	open loop	60	70		dB
B	Unity Gain Bandwidth		0.7	1		MHz
SVR	Supply voltage Rejection	$f = 120\text{Hz}$		70		dB
I_{sink}	Output Sink Current	$V_{COMP} = 1\text{V}$		1		mA
I_{source}	Output Source Current	$V_{COMP} = 3.5\text{V}$; $V_{FB} = 2\text{V}$	-0.5	-1	-2.5	mA
V_{COMPH}	Vout High	$I_{source} = -0.5\text{mA}$; $V_{FB} = 2\text{V}$	3.8	4.50		V
V_{COMPL}	Vout Low	$I_{sink} = 1\text{mA}$; $V_{FB} = 3\text{V}$			1	V

OSCILLATOR SECTION

F_{osc}	Oscillator Frequency	$T_j = 25^\circ\text{C}$	58	65	72	kHz
			52	65	74	
D_{min}	Min. Duty Cycle	$V_{COMP} = 1\text{V}$			0	%
D_{max}	Max. Duty Cycle	$V_{COMP} = 4\text{V}$	67	70	73	%

DEVICE OPERATION SECTION

I_{op}	Operating Supply Current	$f_{sw} = F_{osc}$		4.5	7	mA
I_Q	Quiescent Current	MOS disabled		3.5	6	mA
I_{charge}	V_{CC} charge Current	$V_{CC} = 0\text{V}$ to $V_{CCON} - 0.5\text{V}$; $V_{DS} = 100$ to 400V ; $T_j = 25^\circ\text{C}$	-3	-4.5	-7	mA
		$V_{CC} = 0\text{V}$ to $V_{CCON} - 0.5\text{V}$; $V_{DS} = 100$ to 400V	-2.5	-4.5	-7.5	mA
$V_{CCclamp}$	V_{CC} clamp Voltage	$I_{clamp} = 10\text{mA}$ (*)	16.5	17	17.5	V
V_{CCON}	Start Threshold voltage	(*)	14	14.5	15	V
V_{CCOFF}	Min operating voltage after Turn on	(*)	6	6.5	7	V
V_{DSmin}	Drain start voltage				40	V

ELECTRICAL CHARACTERISTICS (continued)

Symbol	Parameter	Test Condition	Min.	Typ.	Max.	Unit
--------	-----------	----------------	------	------	------	------

CIRCUIT PROTECTIONS

I_{pklim}	Pulse-by-pulse Current Limit	$di/dt = 120 \text{ mA}/\mu\text{s}$	550	625	700	mA
OVP	Overshoot Protection	$I_{CC} = 10 \text{ mA}$ (*)	16	16.5	17	V
LEB	Masking Time	After MOSFET turn-on (**)		120		ns

STANDBY SECTION

F_{SB}	Oscillator Frequency		19	22	25	kHz
$I_{pk sb}$	Peak switch current for Standby Operation	Transition from F_{osc} to F_{SB}		80		mA
$I_{pk no}$	Peak switch current for Normal Operation	Transition from F_{SB} to F_{osc}		190		mA

BROWNOUT PROTECTION (L6590D only)

V_{th}	Threshold Voltage	Voltage either rising or falling	2.4	2.5	2.6	V
I_{Hys}	Current Hysteresis	$V_{pin} = 3V$	-30	-50	-70	μA
V_{CL}	Clamp Voltage	$I_{pin} = 0.5 \text{ mA}$	5.6	6.4	7.2	V

THERMAL SHUTDOWN (***)

	Threshold		150	165		$^{\circ}\text{C}$
	Hysteresis			40		$^{\circ}\text{C}$

(*) Parameters tracking one the other

(**) Parameter guaranteed by design, not tested in production

(***) Parameters guaranteed by design, functionality tested in production

Figure 1. Start-up & UVLO Thresholds

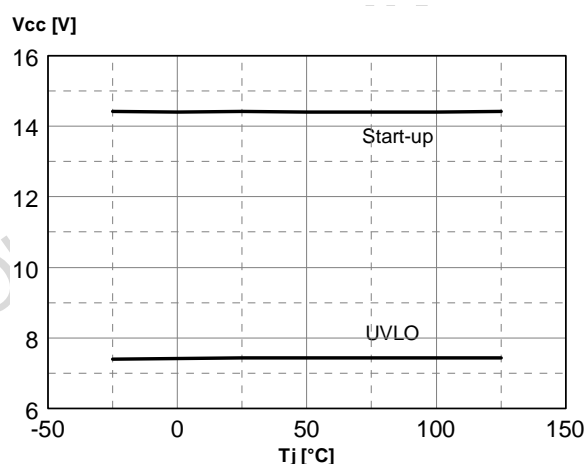

Figure 2. Start-up Current Generator

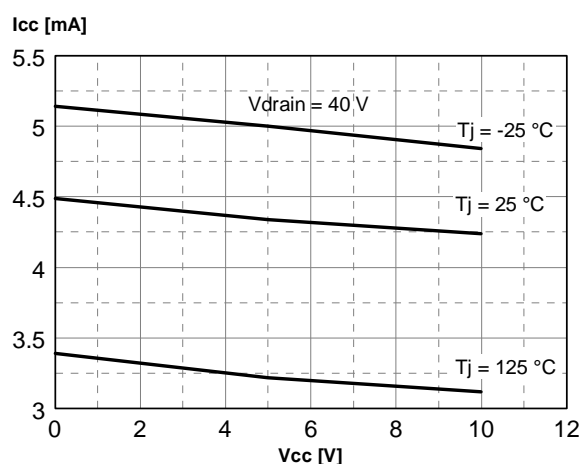

Figure 3. Start-up Current Generator

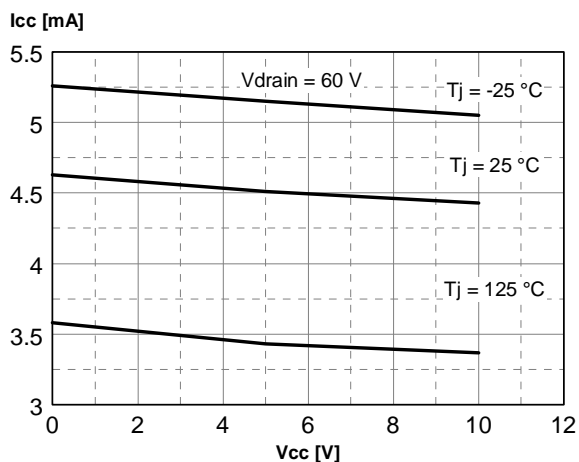

Figure 6. IC Operating Current

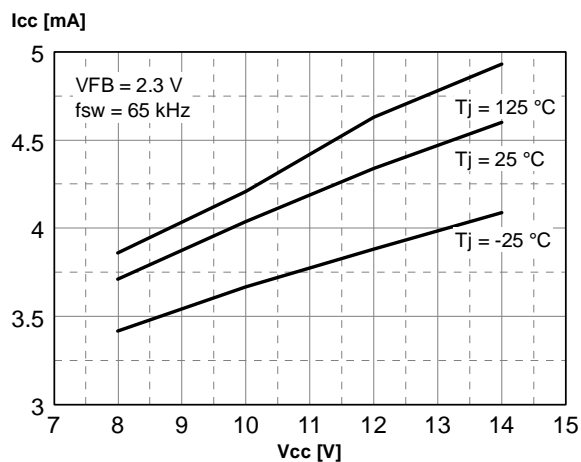

Figure 4. IC Consumption Before Start-up

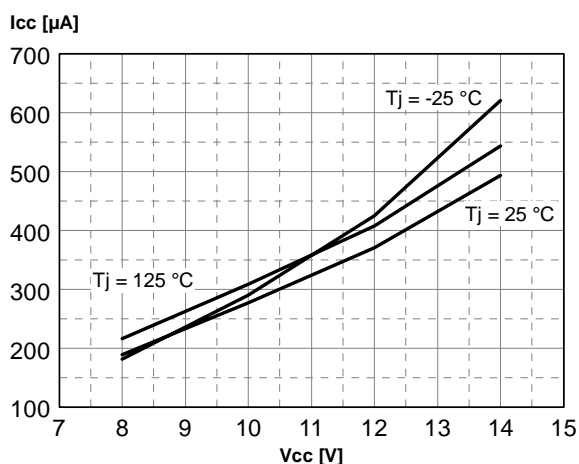

Figure 7. IC Operating Current

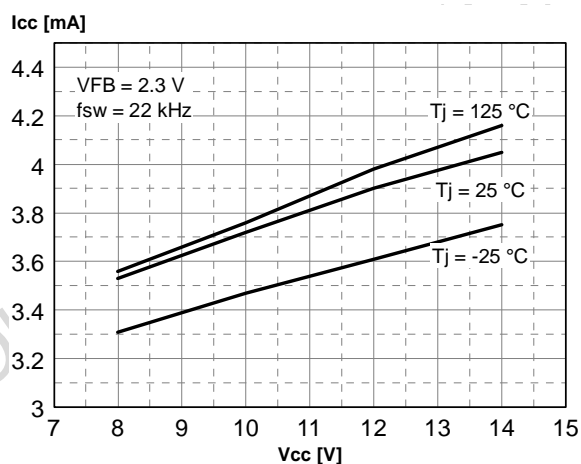

Figure 5. IC Quiescent Current

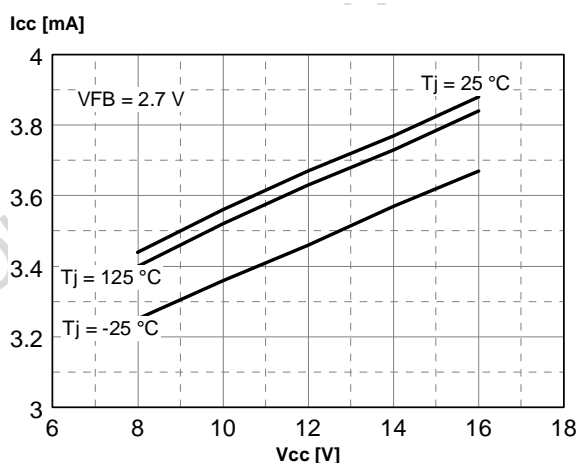

Figure 8. Switching Frequency vs. Temperature

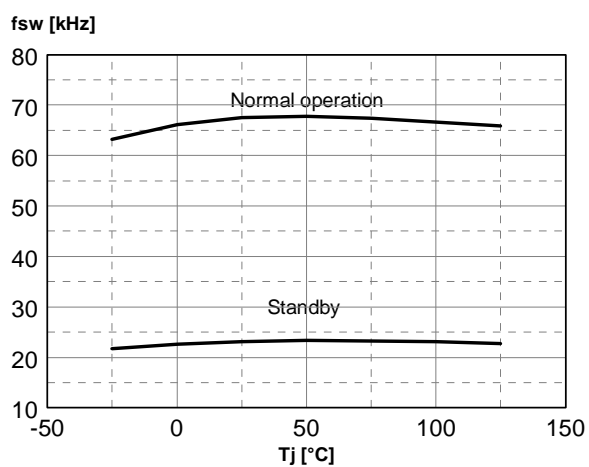

Figure 9. Vcc clamp vs. Temperature

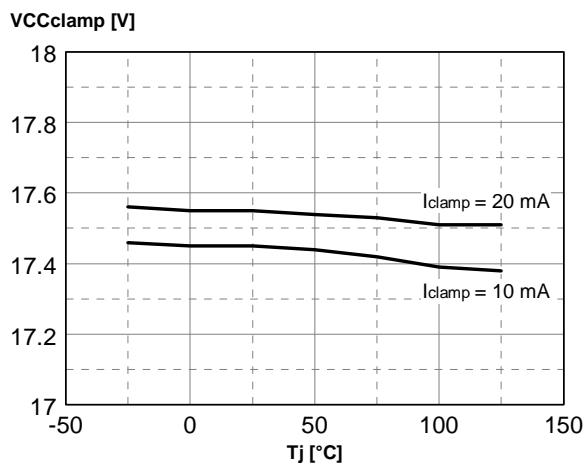

Figure 12. OCP threshold vs. Temperature

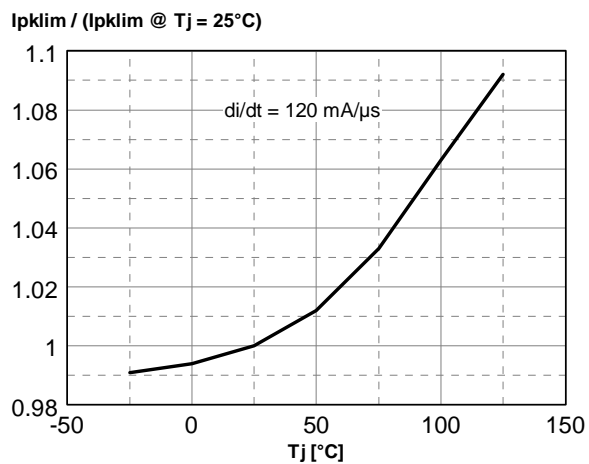

Figure 10. OVP Threshold vs. Temperature

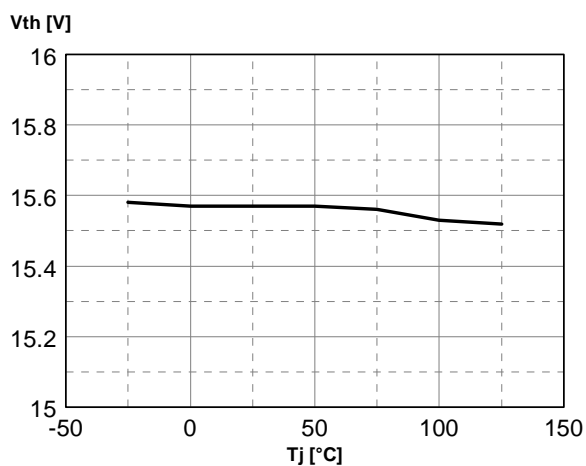

Figure 13. Internal E/A Reference Voltage

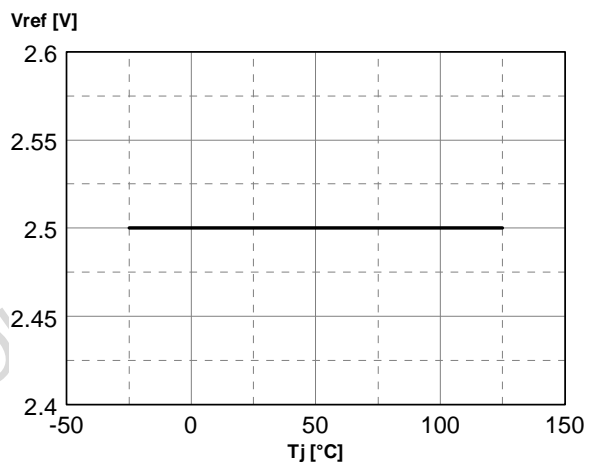

Figure 11. OCP Threshold vs. Current Slope

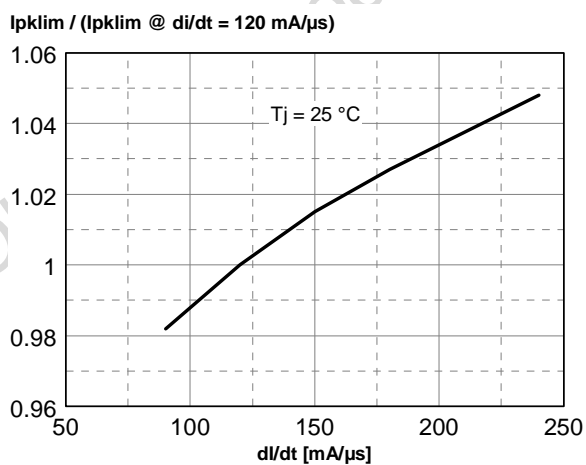

Figure 14. Error Amplifier Slew Rate

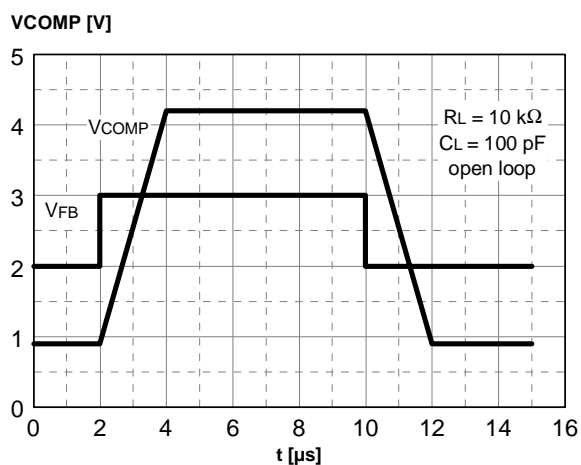

Figure 15. COMP pin Characteristic

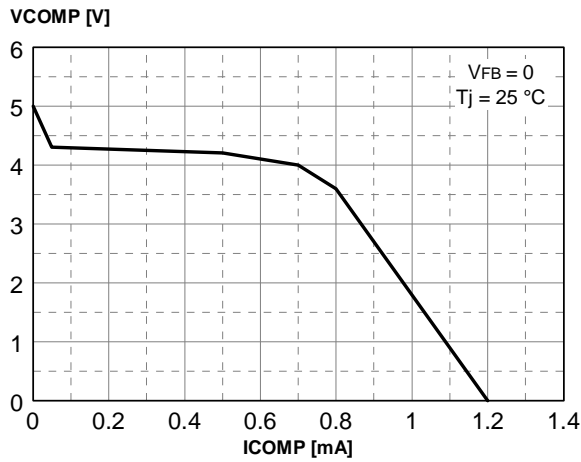

Figure 16. COMP pin Dynamic Resistance vs. Temperature

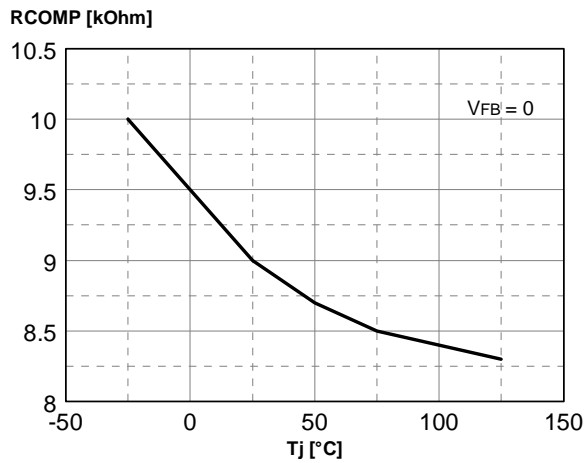

Figure 17. Error Amplifier Gain and Phase

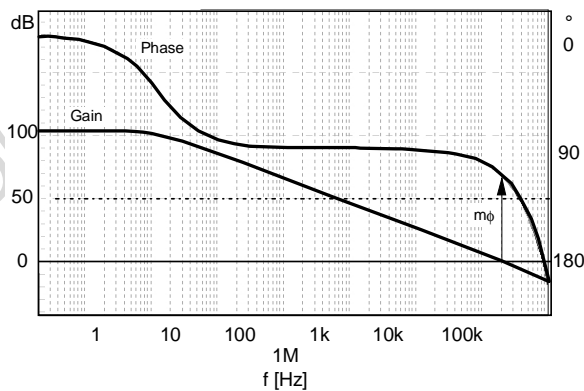

Figure 18. Breakdown Voltage vs. Temperature

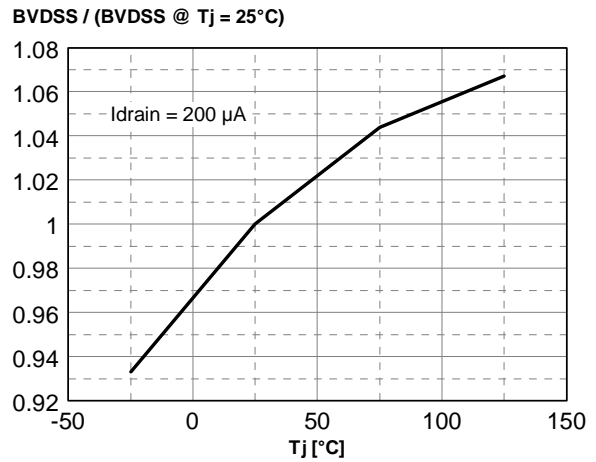

Figure 19. Drain Leakage vs. Drain Voltage

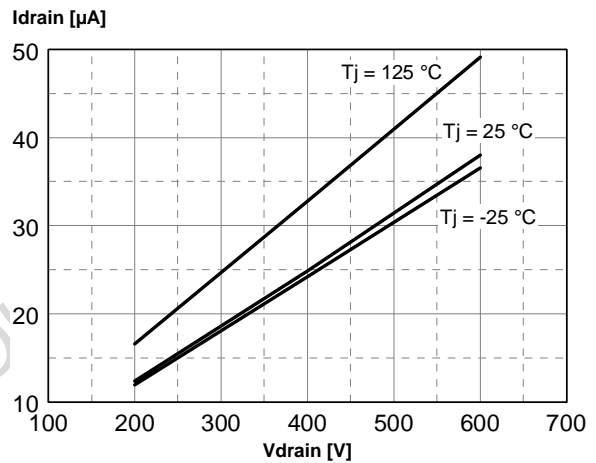

Figure 20. Rds(ON) vs. Temperature

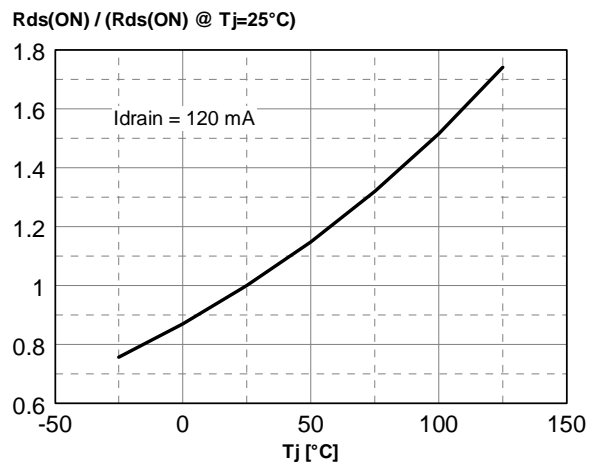

Figure 21. Rds(ON) vs. Idrain

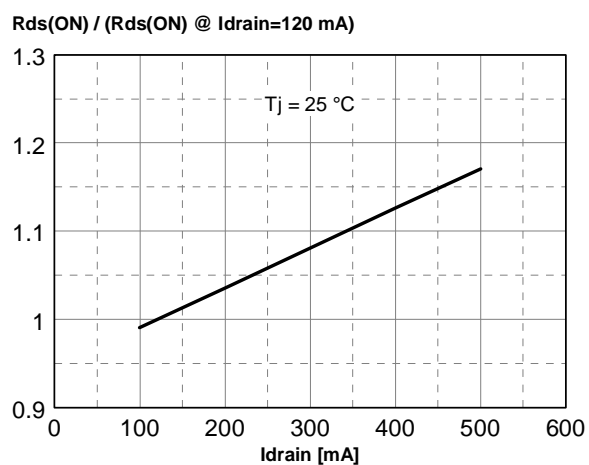

Figure 22. Coss vs. Drain Voltage

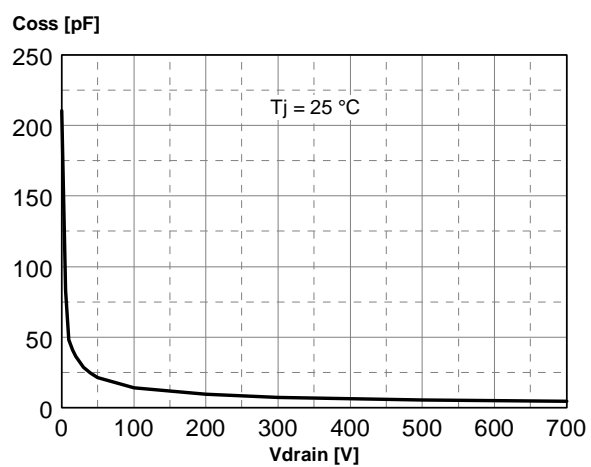

Figure 23. Standby Function Thresholds

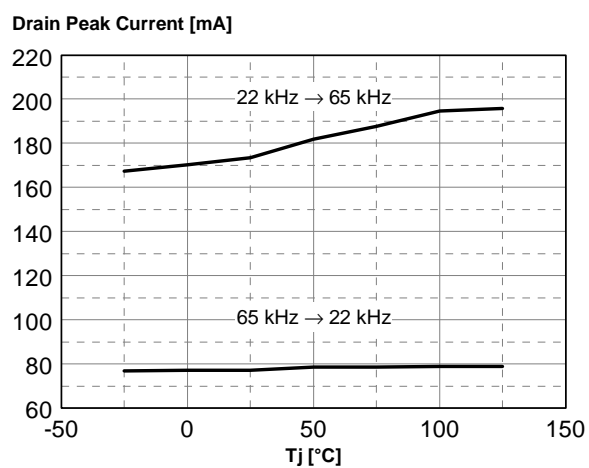

Figure 24. Test Board (1) with Primary Feedback: Electrical Schematic

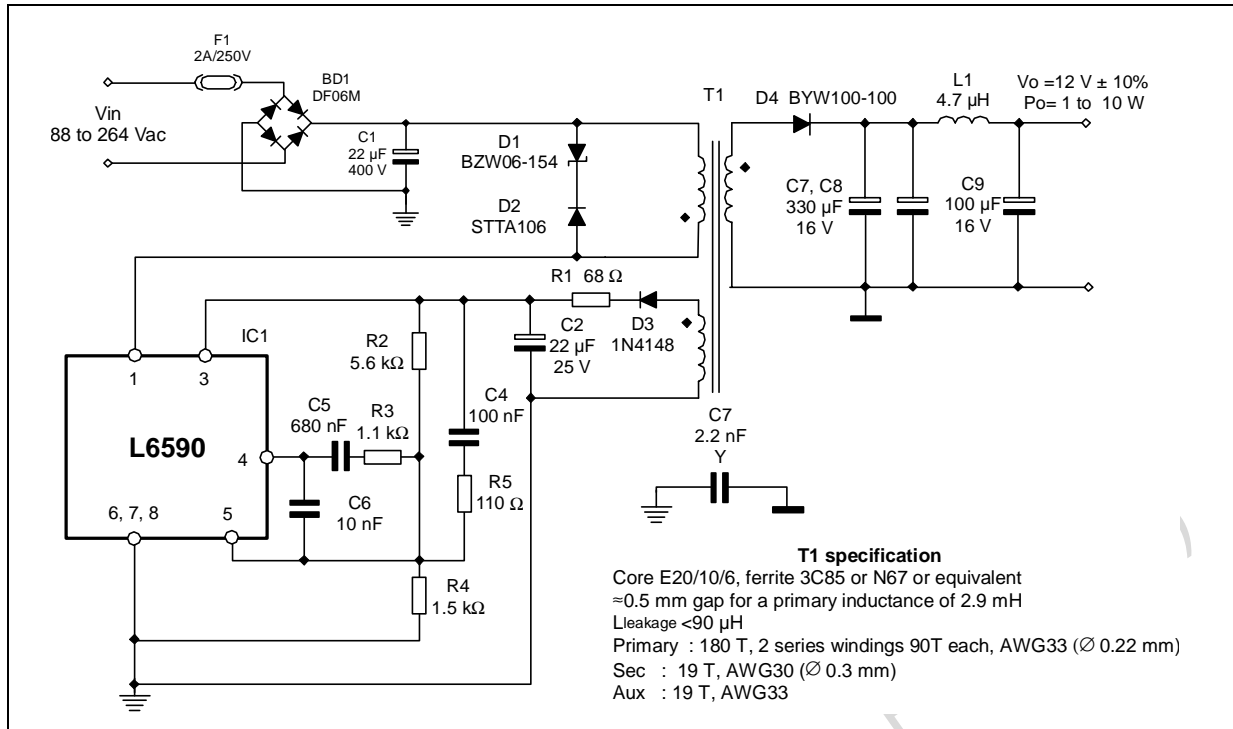

Figure 25. Test Board (1) Evaluation Data

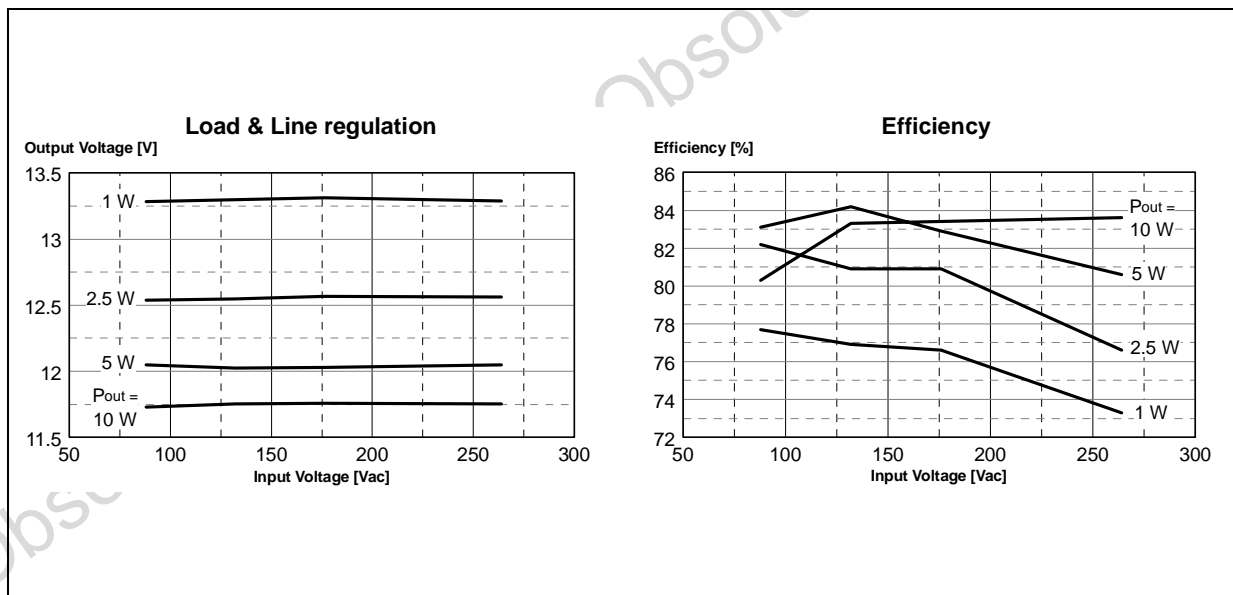

Figure 28. Test Board (2) evaluation data

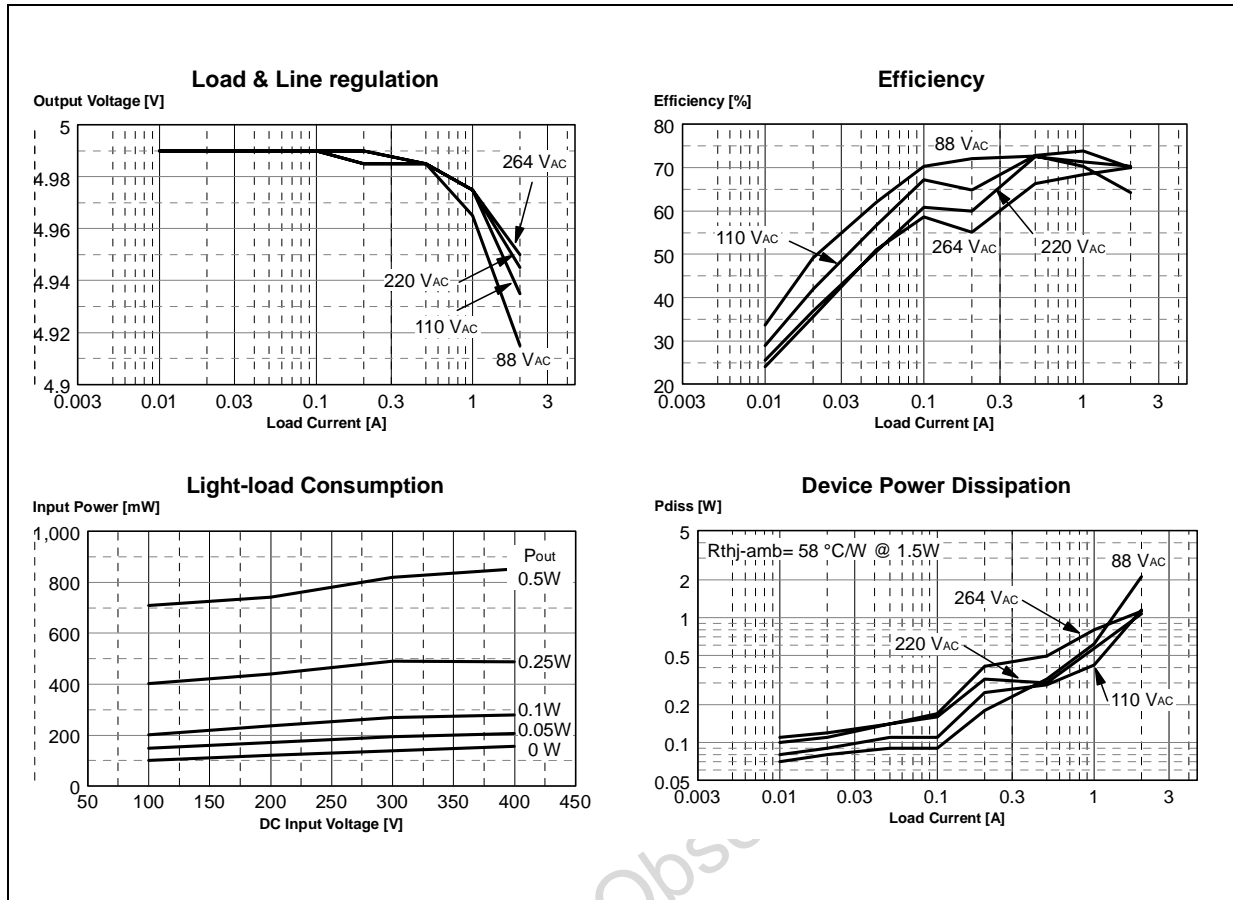

Figure 29. Test Board (2) EMI Characterization

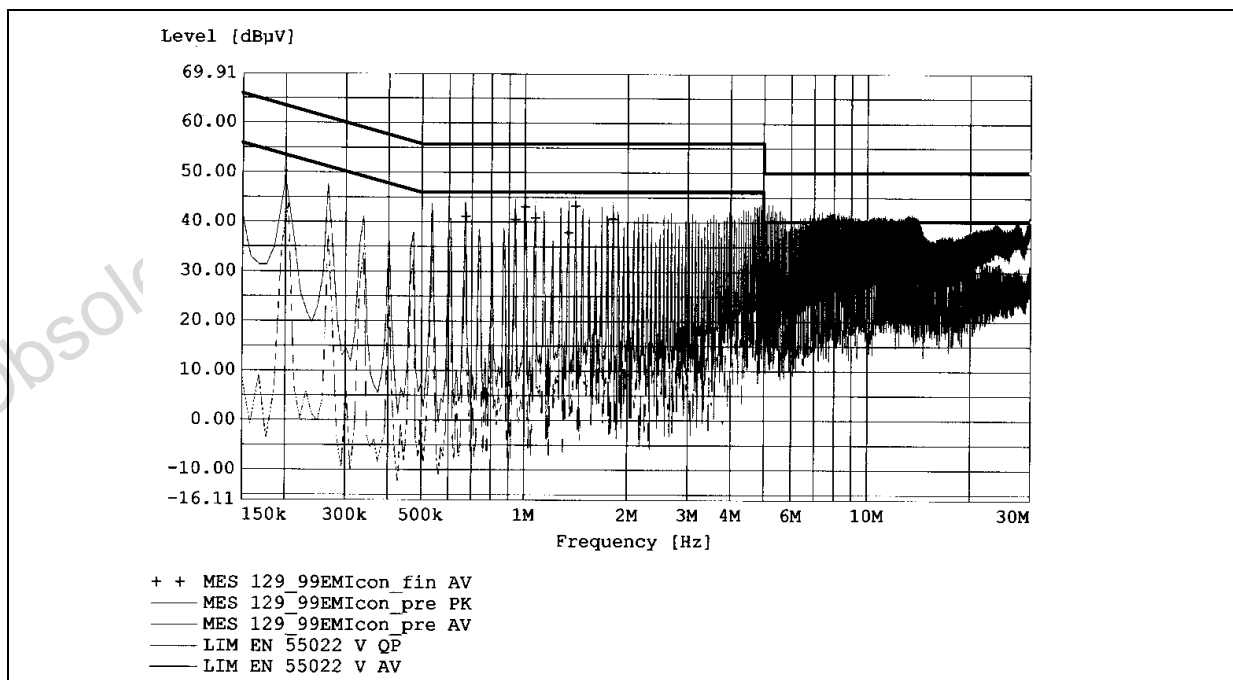

Figure 30. Test Board (2) Main Waveforms

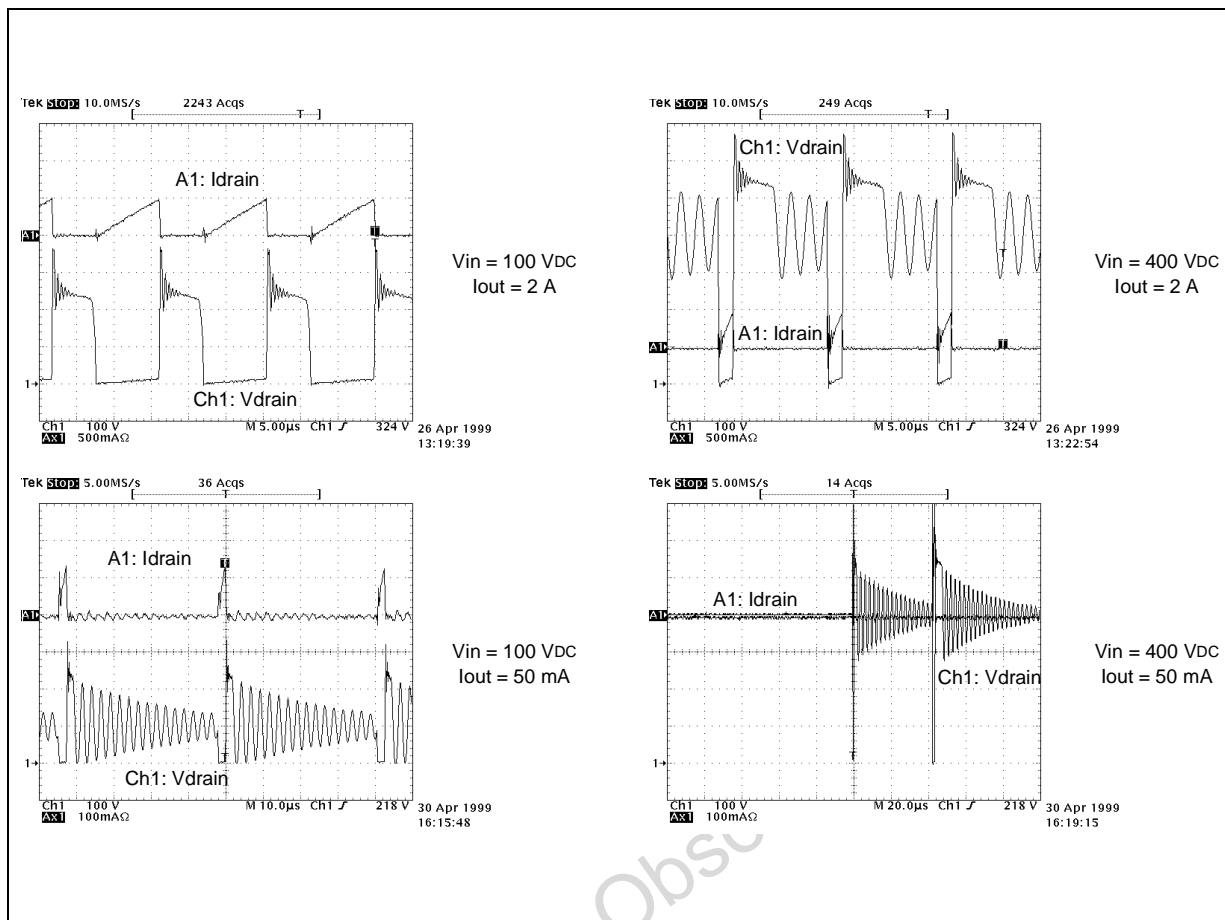
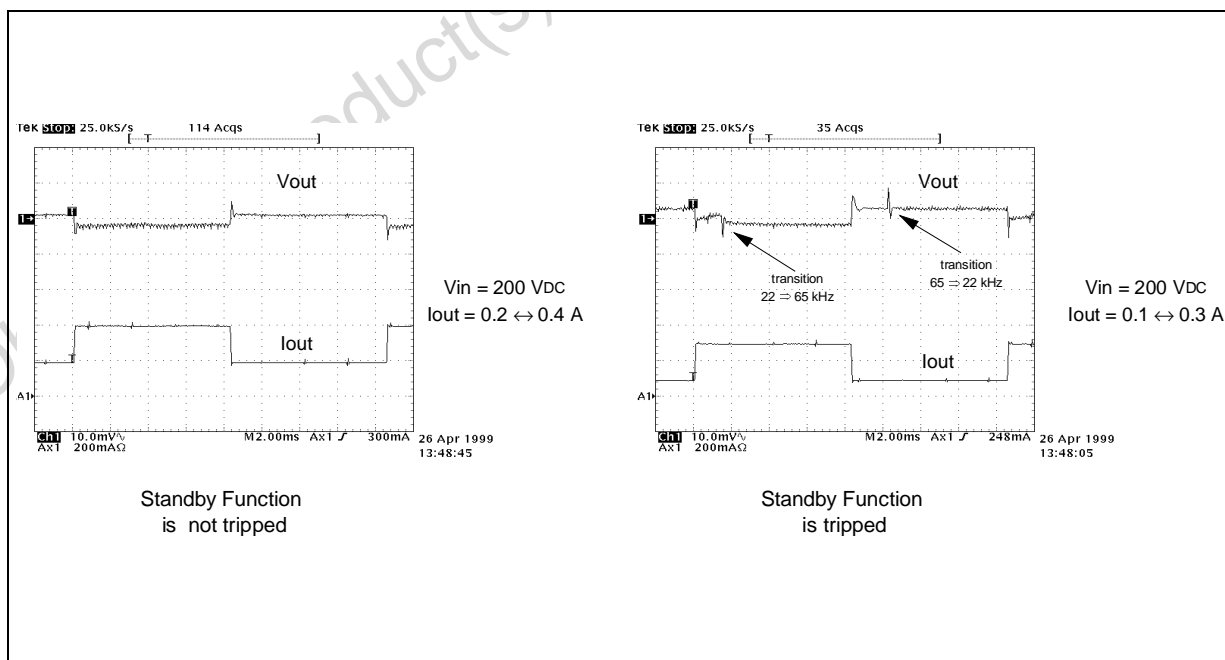

Figure 31. Test Board (2) Load Transient Response



APPLICATION INFORMATION

In the following sections the functional blocks as well as the most important internal functions of the device will be described.

Start-up Circuit

When power is first applied to the circuit and the voltage on the bulk capacitor is sufficiently high, an internal high-voltage current generator is sufficiently biased to start operating and drawing about 4.5 mA through the primary winding of the transformer and the drain pin. Most of this current charges the bypass capacitor connected between pin Vcc (3) and ground and makes its voltage rise linearly.

As the Vcc voltage reaches the start-up threshold (14.5V typ.) the chip, after resetting all its internal logic, starts operating, the internal power MOSFET is enabled to switch and the internal high-voltage generator is disconnected. The IC is powered by the energy stored in the Vcc capacitor until the self-supply circuit (typically an auxiliary winding of the transformer) develops a voltage high enough to sustain the operation.

As the IC is running, the supply voltage, typically generated by a self-supply winding, can range between 16 V (Overvoltage protection limit, see the relevant section) and 7 V, threshold of the Undervoltage Lockout. Below this value the device is switched off (and the internal start-up generator is activated). The two thresholds are in tracking.

The voltage on the Vcc pin is limited at safe values by a clamp circuit. Its 17V threshold tracks the Overvoltage protection threshold.

Figure 32. Start-up circuit internal schematic

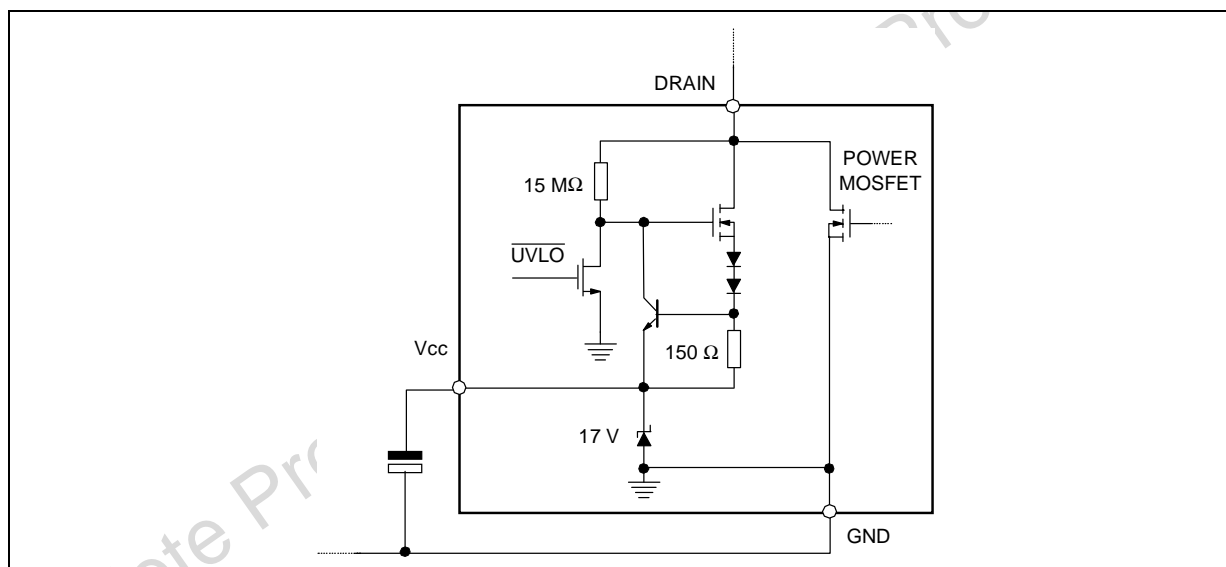

Power MOSFET and Gate Driver

The power switch is implemented with a lateral N-channel MOSFET having a $V_{(BR)DSS}$ of 700V min. and a typical $R_{DS(on)}$ of 13Ω. It has a SenseFET structure to allow a virtually lossless current sensing (used only for protection).

During operation in Discontinuous Conduction Mode at low mains the drain voltage is likely to go below ground. Any risk of injecting the substrate of the IC is prevented by an internal structure surrounding the switch.

The gate driver of the power MOSFET is designed to supply a controlled gate current during both turn-on and turn-off in order to minimize common mode EMI.

Under UVLO conditions an internal pull-down circuit holds the gate low in order to ensure that the power MOSFET cannot be turned on accidentally.

Figure 33. PWM Control internal schematic

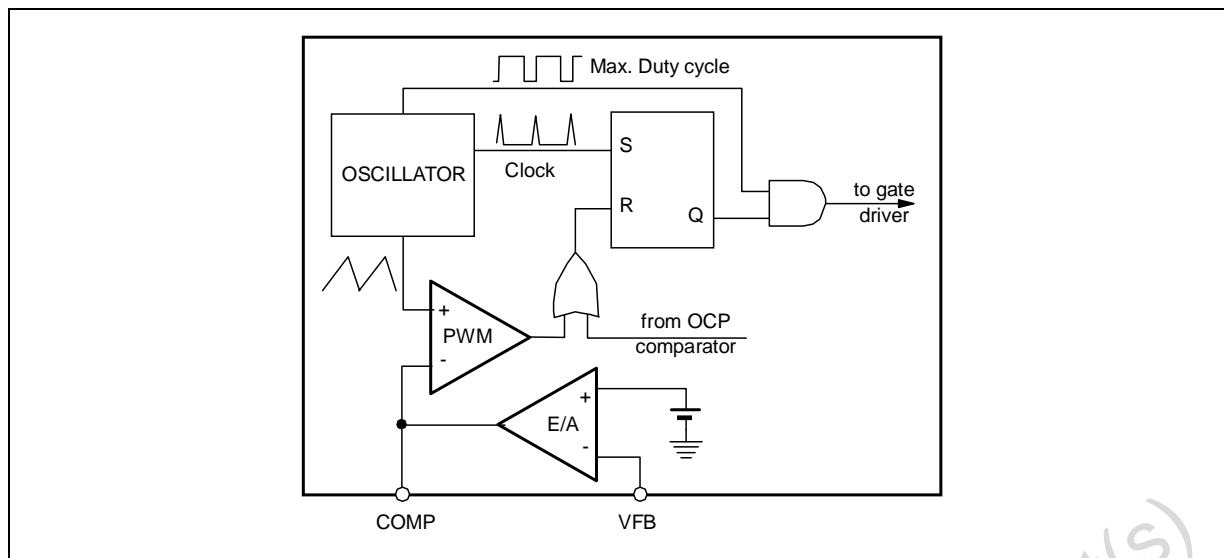

Oscillator and PWM Control

PWM regulation is accomplished by implementing voltage mode control. As shown in fig. 33, this block includes an oscillator, a PWM comparator, a PWM latch and an Error Amplifier.

The oscillator operates at a frequency internally fixed at 65 kHz with a precision of $\pm 10\%$. The maximum duty cycle is limited at 70% typ.

The PWM latch (reset dominant) is set by the clock pulses of the oscillator and is reset by either the PWM comparator or the Overcurrent comparator.

The Error Amplifier (E/A) is an op-amp with a MOS input stage and a class AB output stage. The amplifier is compensated for closed loop stability at unity gain, has a small-signal DC gain of 70 dB (typ.) and a gain-bandwidth product over 1 MHz.

In case of overcurrent the error amplifier output saturates high and the conduction of the power MOSFET is stopped by the OCP comparator instead of the PWM comparator.

Under zero load conditions the error amplifier is close to its low saturation and the gate drive delivers as short pulses as it can, limited by internal delays. They are however too long to maintain the long-term energy balance, thus from time to time some cycles need being skipped and the operation becomes asynchronous. This is automatically done by the control loop.

Standby Function

The standby function, optimized for flyback topology, automatically detects a light load condition for the converter and decreases the oscillator frequency. The normal oscillation frequency is automatically resumed when the output load builds up and exceeds a defined threshold.

This function allows to minimize power losses related to switching frequency, which represent the majority of losses in a lightly loaded flyback, without giving up the advantages of a higher switching frequency at heavy load.

The Standby function is realized by monitoring the peak current in the power switch. If the load is low that it does not reach a threshold (80 mA typ.), the oscillator frequency will be set at 22 kHz typ.

When the load demands more power and the peak primary current exceeds a second threshold (190 mA typ.) the oscillator frequency is reset at 65 kHz. This 110 mA hysteresis prevents undesired frequency change when power is such that the peak current is close to either threshold.

The signal coming from the sense circuit is digitally filtered to avoid false triggering of this function as a result of large load changes or noise.

Figure 34. Standby Function timing diagram

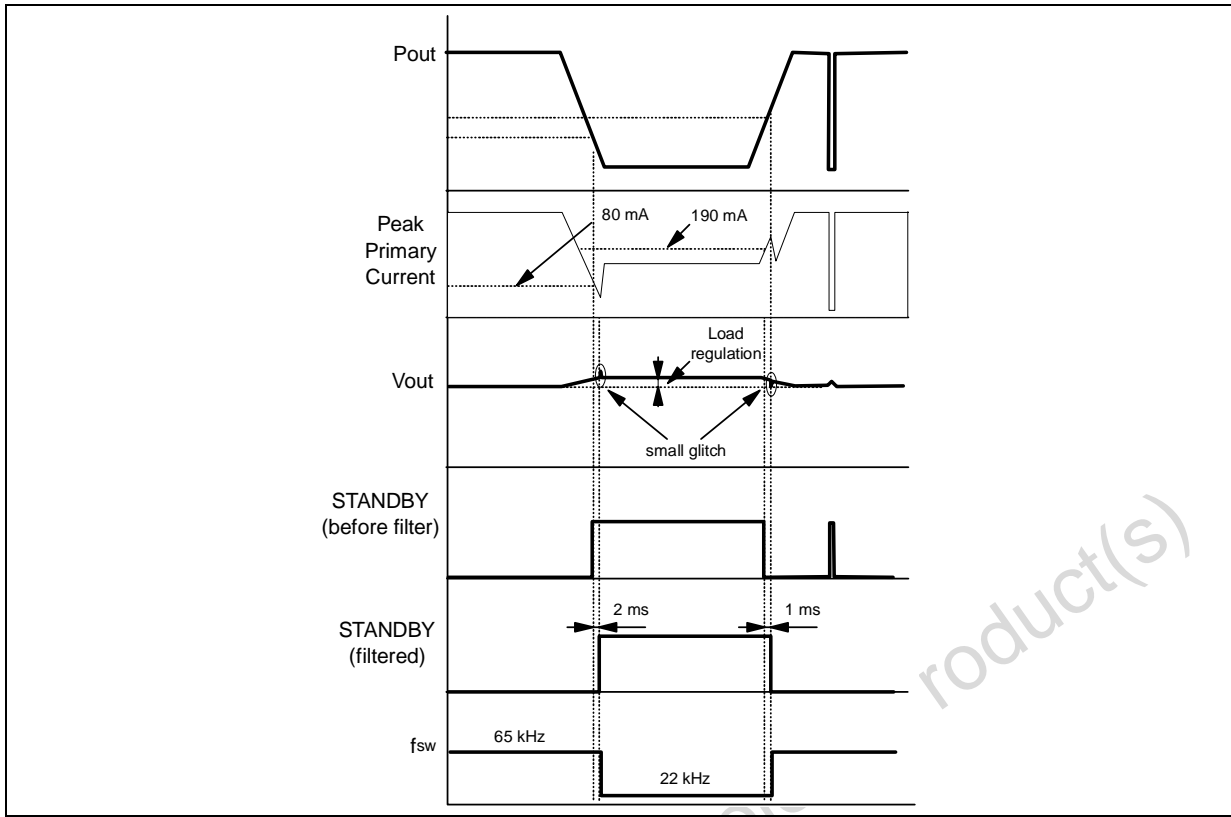

Brownout Protection (L6590D only)

Brownout Protection is basically a not-latched device shutdown functionality. It will typically be used to detect a mains undervoltage (brownout). This condition may cause overheating of the primary power section due to an excess of RMS current.

Figure 35. Brownout Protection Function internal schematic and timing diagram

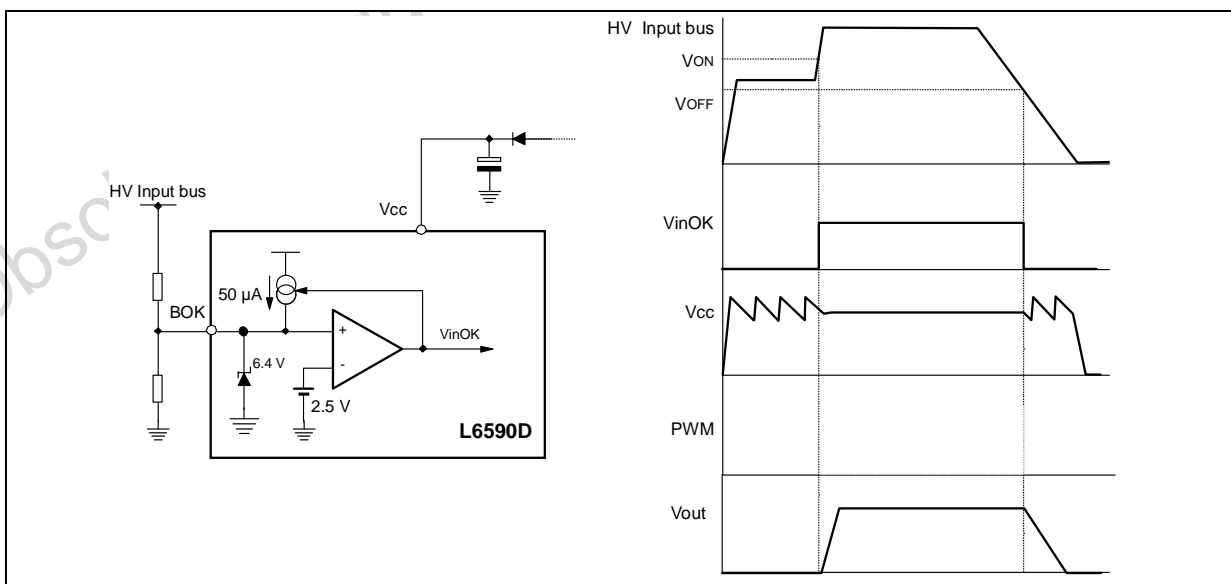

Another problem is the spurious restarts that are likely to occur during converter power down if the input voltage decays slowly (e.g. with a large input bulk capacitor) and that cause the output voltage not to decay to zero monotonically.

Converter shutdown can be accomplished with the L6590D by means of an internal comparator that can be used to sense the voltage across the input bulk capacitor. This comparator is internally referenced to 2.5V and disables the PWM if the voltage applied at its non-inverting input, externally available, is below the reference. PWM operation is re-enabled as the voltage at the pin is more than 2.5V.

The brownout comparator is provided with current hysteresis instead of a more usual voltage hysteresis: an internal 50 μA current generator is ON as long as the voltage applied at the non-inverting input exceeds 2.5V and is OFF if the voltage is below 2.5V. This approach provides an additional degree of freedom: it is possible to set the ON threshold and the OFF threshold separately by properly choosing the resistors of the external divider, which is not possible with voltage hysteresis.

Overvoltage Protection

The IC incorporates an Overvoltage Protection (OVP) that can be particularly useful to protect the converter and the load against voltage feedback loop failures. This kind of failure causes the output voltage to rise with no control and easily leads to the destruction of the load and of the converter itself if not properly handled.

If such an event occurs, the voltage generated by the auxiliary winding that supplies the IC will fly up tracking the output voltage. An internal comparator continuously monitors the V_{CC} voltage and stops the operation of the IC if the voltage exceeds 16.5 V. This condition is latched and maintained until the V_{CC} voltage falls below the UVLO threshold. The converter will then operate intermittently.

Figure 36. OVP internal schematic

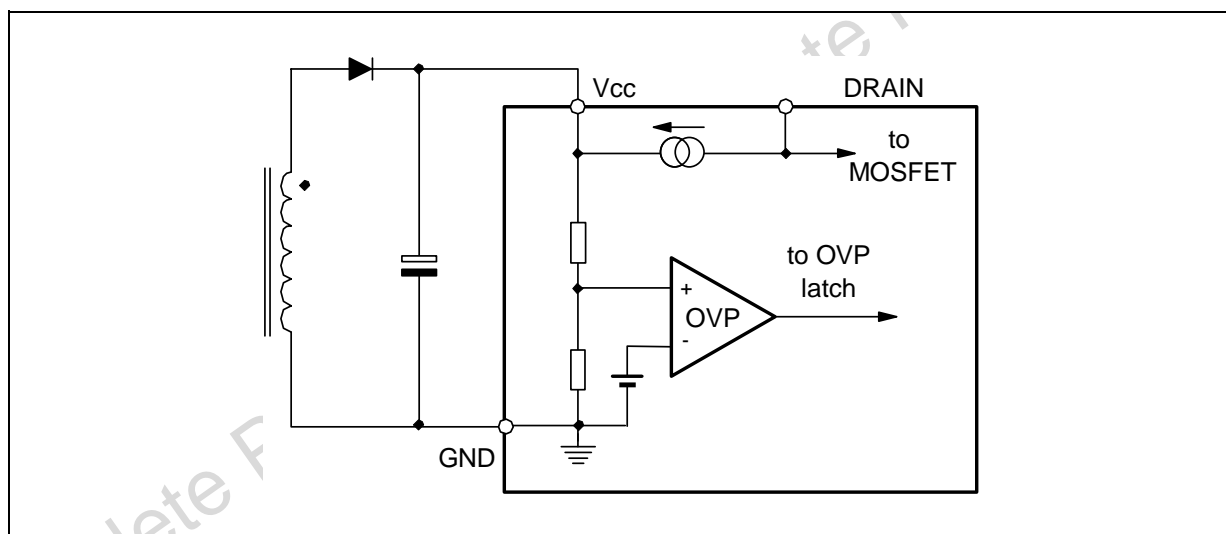

Overcurrent Protection

The device uses pulse-by-pulse current limiting for Overcurrent Protection (OCP), in order to prevent overstress of the internal MOSFET: its current during the ON-time is monitored and, if it exceeds a determined value, the conduction is terminated immediately. The MOSFET will be turned on again in the subsequent switching cycle.

As previously mentioned, the internal powerMOSFET has a SenseFET structure: the source of a few cells are connected together and kept separate from the other source connections so as to realize a 1:100 current divider. The "sense" portion is connected to a ground referenced, sense resistor having a low thermal coefficient. The OCP comparator senses the voltage drop across the sense resistor and resets the PWM latch if the drop exceeds a threshold, thus turning off the MOSFET. In this way the overcurrent threshold is set at about 0.65 A (typical value).

At turn-on, there are large current spikes due to the discharge of parasitic capacitances and, in case of Continuous Conduction Mode operation, to secondary diode reverse recovery as well, which could falsely trigger the OCP comparator. To increase noise immunity the output of the OCP comparator is blanked for a short time (about 120 ns) just after the MOSFET is turned on, so that any disturbance within this time slot is rejected (Leading Edge Blanking).

Figure 37. OCP internal schematic

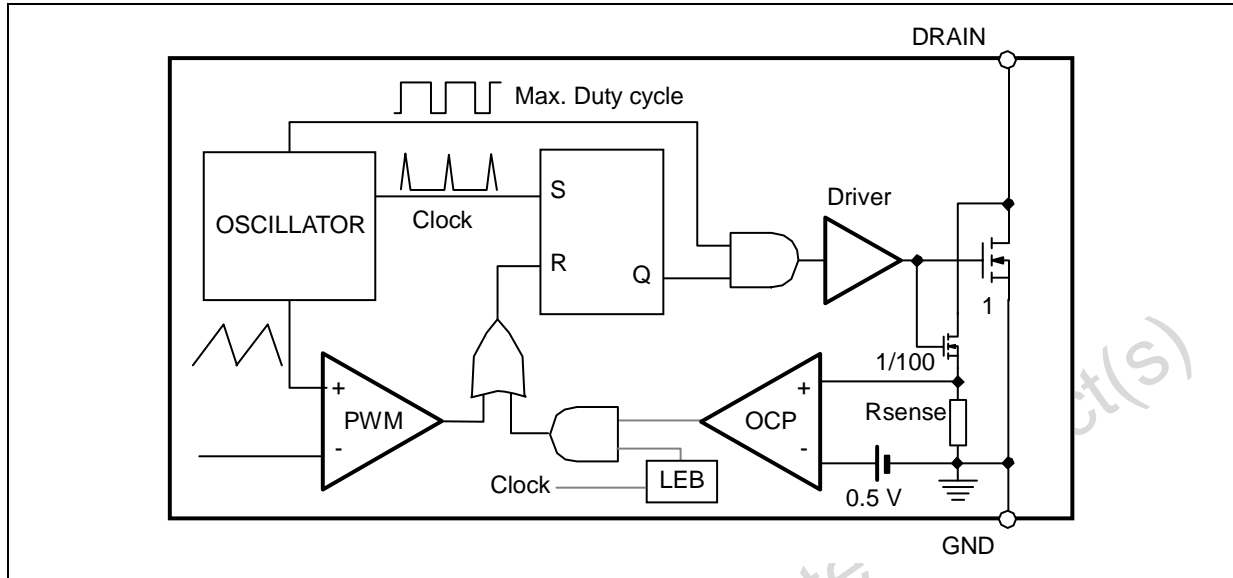

Thermal Shutdown

Overheating of the device due to an excessive power throughput or insufficient heatsinking is avoided by the Thermal Shutdown function. A thermal sensor monitors the junction temperature close to the power MOSFET and, when the temperature exceeds 150 °C (min.), sets an alarm signal that stops the operation of the device. This is a not-latched function and the power MOSFET is re-enabled as the temperature falls about 40 °C.

APPLICATION IDEAS

Figure 38. 10W AC-DC adapter with no isolation

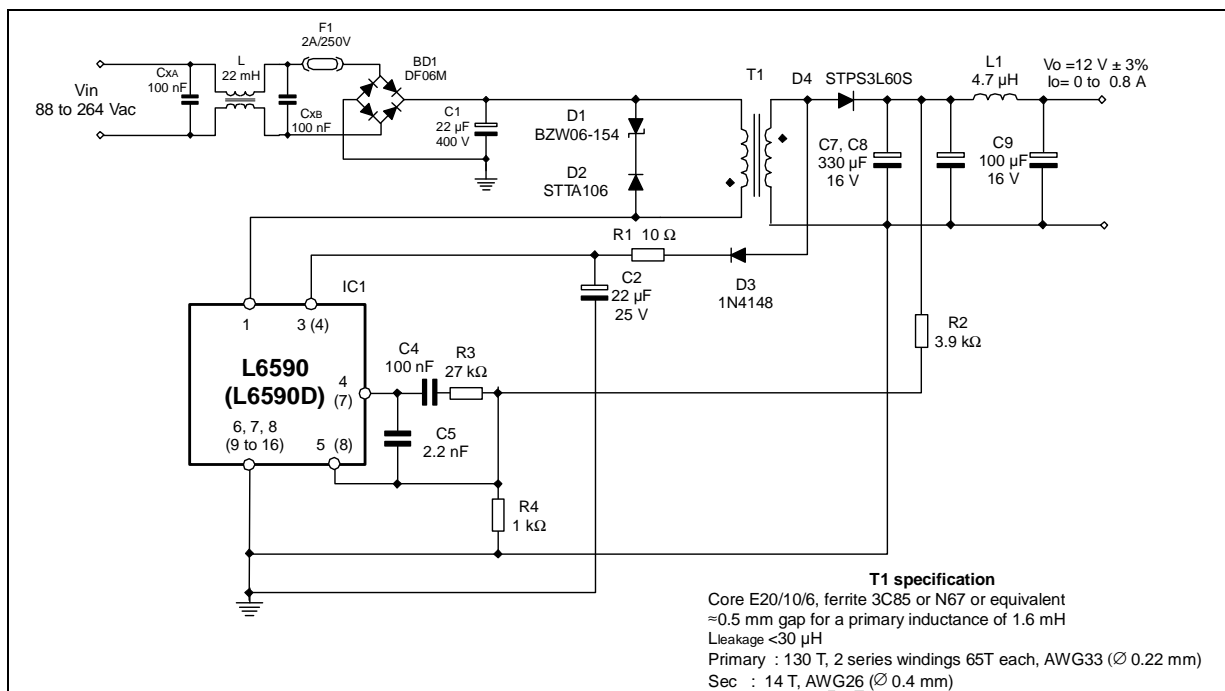

Figure 39. 15W Auxiliary SMPS for PC

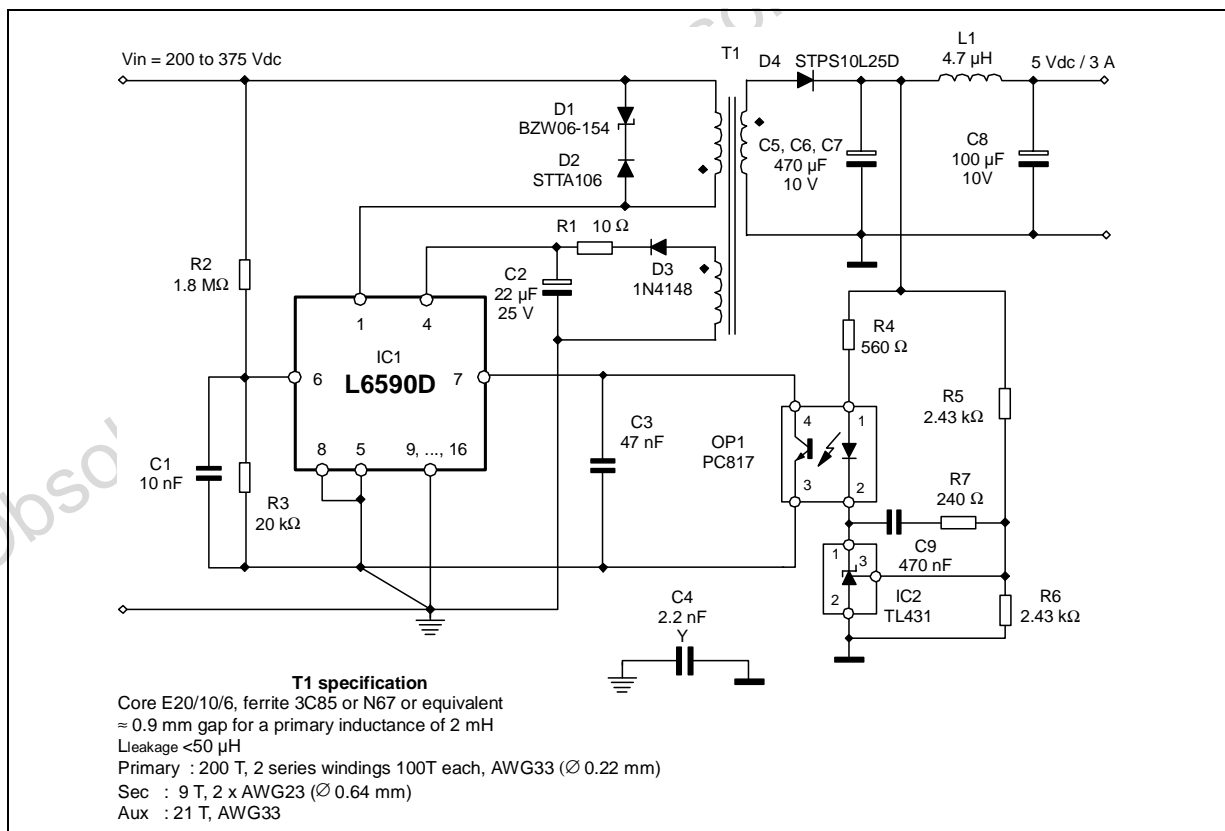
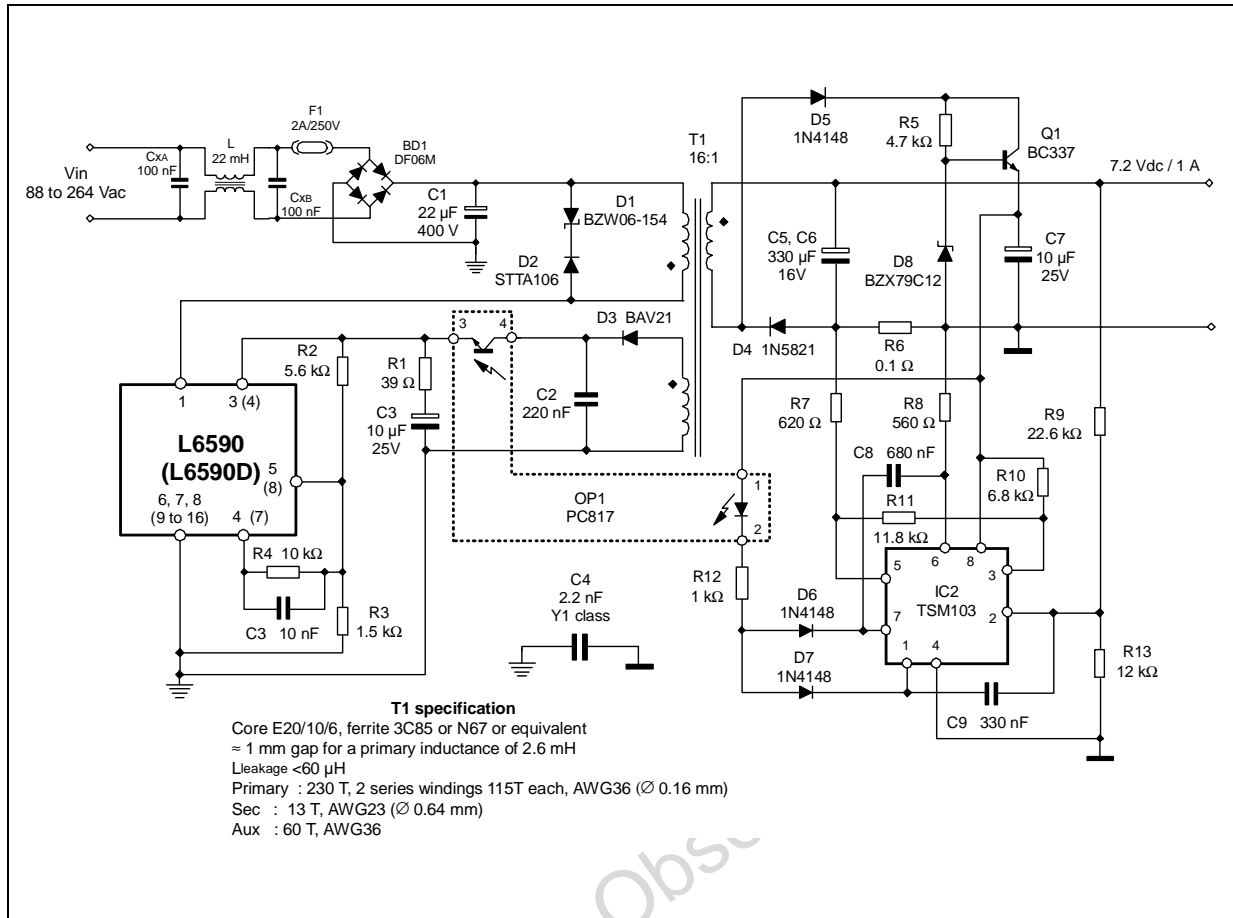

Figure 40. 7.2V/7W Battery Charger



REFERENCES

- [1] "Getting Familiar with the L6590 Family, High-voltage Fully Integrated Power Supply" (AN1261)
- [2] "Offline Flyback Converters Design Methodology with the L6590 Family" (AN1262)

DIM.	mm			inch		
	MIN.	TYP.	MAX.	MIN.	TYP.	MAX.
A		3.32			0.131	
a1	0.51			0.020		
B	1.15		1.65	0.045		0.065
b	0.356		0.55	0.014		0.022
b1	0.204		0.304	0.008		0.012
D			10.92			0.430
E	7.95		9.75	0.313		0.384
e		2.54			0.100	
e3		7.62			0.300	
e4		7.62			0.300	
F			6.6			0.260
I			5.08			0.200
L	3.18		3.81	0.125		0.150
Z			1.52			0.060

OUTLINE AND MECHANICAL DATA

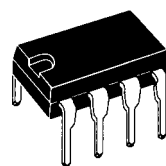

Minidip

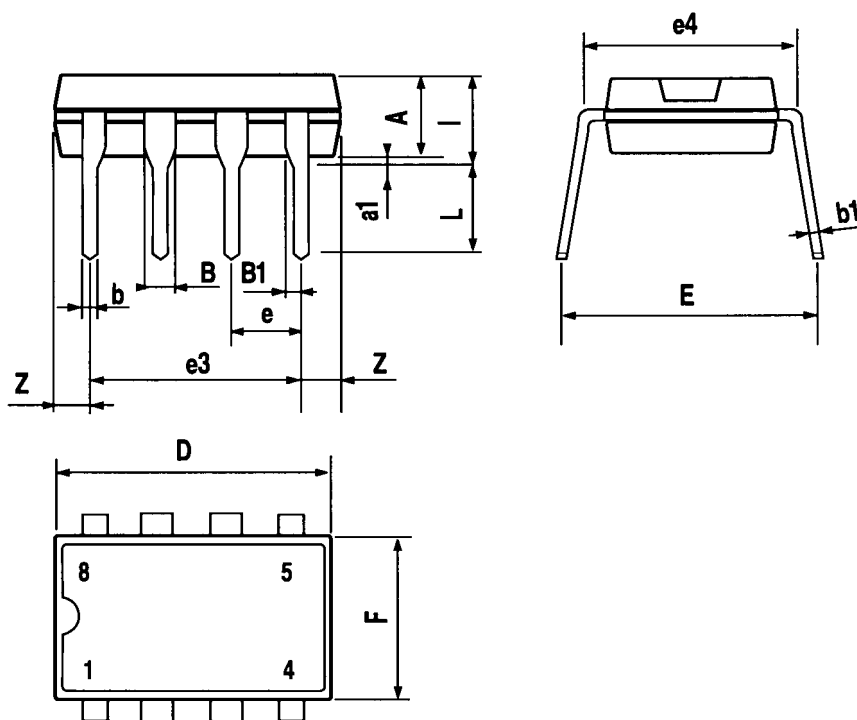

DIM.	mm			inch		
	MIN.	TYP.	MAX.	MIN.	TYP.	MAX.
A	2.35		2.65	0.093		0.104
A1	0.1		0.3	0.004		0.012
B	0.33		0.51	0.013		0.020
C	0.23		0.32	0.009		0.013
D	10.1		10.5	0.398		0.413
E	7.4		7.6	0.291		0.299
e		1.27			0.050	
H	10		10.65	0.394		0.419
h	0.25		0.75	0.010		0.030
L	0.4		1.27	0.016		0.050
K	0° (min.)8° (max.)					

OUTLINE AND MECHANICAL DATA

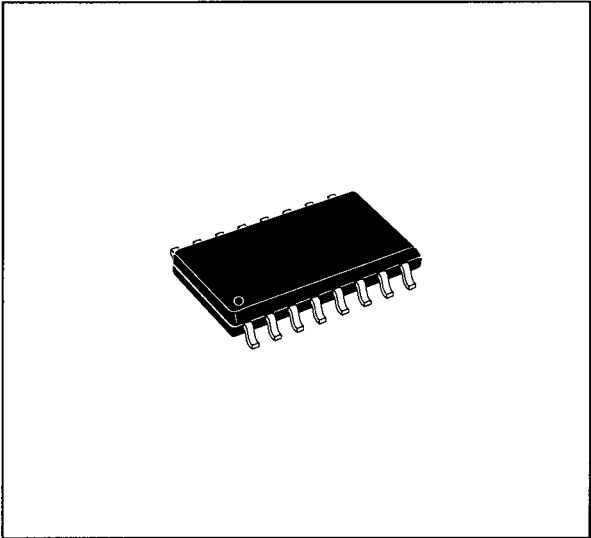

SO16 Wide

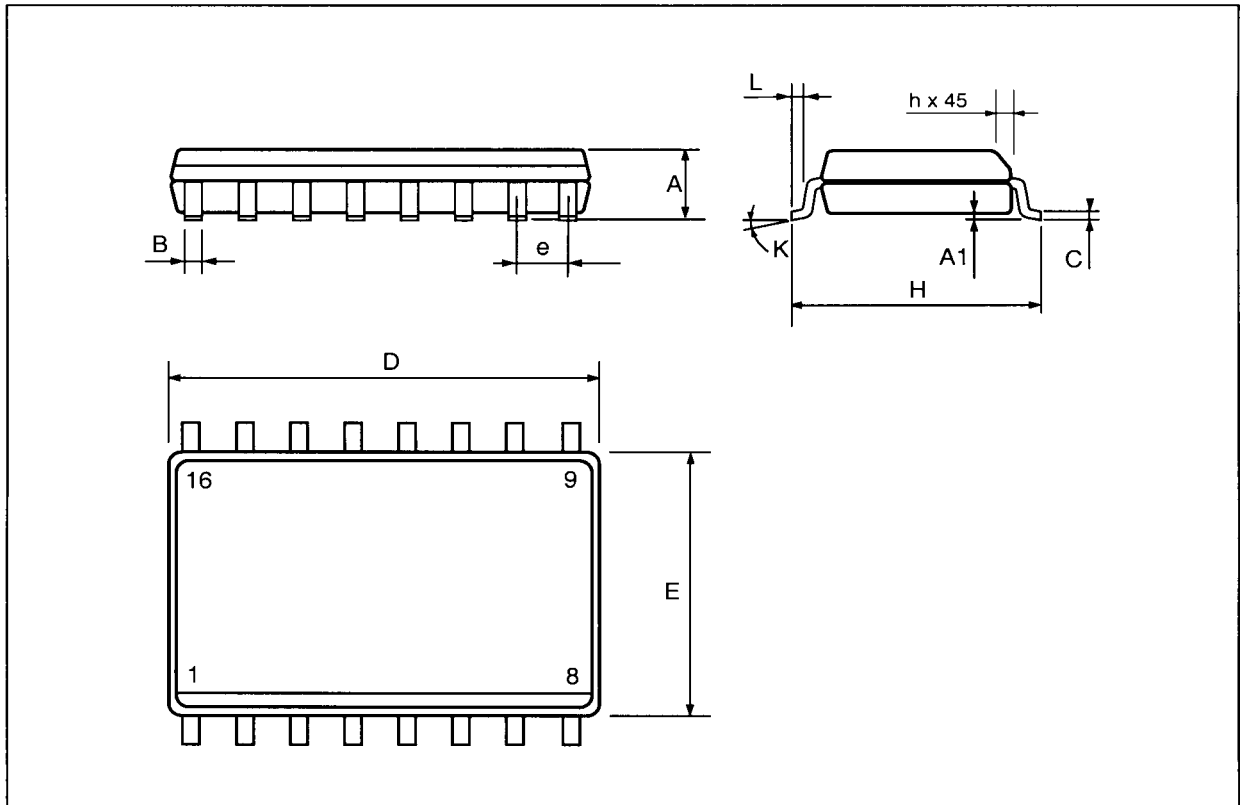

Information furnished is believed to be accurate and reliable. However, STMicroelectronics assumes no responsibility for the consequences of use of such information nor for any infringement of patents or other rights of third parties which may result from its use. No license is granted by implication or otherwise under any patent or patent rights of STMicroelectronics. Specifications mentioned in this publication are subject to change without notice. This publication supersedes and replaces all information previously supplied. STMicroelectronics products are not authorized for use as critical components in life support devices or systems without express written approval of STMicroelectronics.

The ST logo is a registered trademark of STMicroelectronics
© 2000 STMicroelectronics - All Rights Reserved

STMicroelectronics GROUP OF COMPANIES
Australia - Brazil - China - Finland - France - Germany - Hong Kong - India - Italy - Japan - Malaysia - Malta - Morocco - Singapore - Spain
- Sweden - Switzerland - United Kingdom - U.S.A.
<http://www.st.com>



Looking for pricing, stock, or lifecycle information?

Click below to explore more details on WIN SOURCE:

 [View L6590ED013TR](#) on WIN SOURCE

 [STMicroelectronics](#) Information

Optimize Your Supply Chain with WIN SOURCE Solutions

-  Global Sourcing Solution
-  Obsolete Management
-  Cost Control Management
-  Shortage Management
-  Alternative Solution
-  Excess Inventory Management