



THE DATASHEET OF L6384E



High voltage half-bridge driver

Datasheet - production data

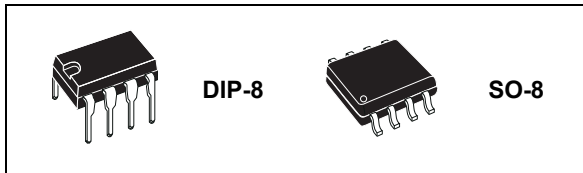

Features

- High voltage rail up to 600 V
- dV/dt immunity ± 50 V/nsec in full temperature range
- Driver current capability
 - 400 mA source
 - 650 mA sink
- Switching times 50/30 nsec rise/fall with 1 nF load
- CMOS/TTL Schmitt trigger inputs with hysteresis and pull-down
- Shutdown input
- Deadtime setting
- Undervoltage lockout
- Integrated bootstrap diode
- Clamping on V_{CC}
- Available in DIP-8/SO-8 packages

Applications

- Home appliances
- Induction heating
- HVAC
- Industrial applications and drives
- Motor drivers
 - DC, AC, PMDC and PMAC motors
- Lighting applications
- Factory automation
- Power supply systems

Description

The L6384E is a high voltage gate driver, manufactured with the BCD™ “offline” technology, and able to drive a half-bridge of power MOSFET or IGBT devices. The high-side (floating) section is able to work with voltage rail up to 600 V. Both device outputs can sink and source 650 mA and 400 mA respectively and cannot be simultaneously driven high thanks to single input configuration. Further prevention from outputs cross conduction is guaranteed by the deadtime function, tunable by the user through an external resistor connected to the DT/SD pin.

The L6384E device has one input pin, one enable pin (DT/SD) and two output pins, and guarantees matched delays between low-side and high-side sections, thus simplifying device's high frequency operation. The logic inputs are CMOS/TTL compatible to ease the interfacing with controlling devices. The bootstrap diode is integrated inside the device, allowing a more compact and reliable solution.

The L6384E features the UVLO protection and a voltage clamp on the V_{CC} supply voltage. The voltage clamp is typically around 15.6 V and is useful in order to ensure a correct device functioning in cases where V_{CC} supply voltage is ramped up too slowly or is subject to voltage drops.

The device is available in a DIP-8 tube and SO-8 tube and tape and reel packaging options.

Contents

1	Block diagram	3
2	Electrical data	4
2.1	Absolute maximum ratings	4
2.2	Thermal data	4
2.3	Recommended operating conditions	5
3	Pin connection	6
4	Electrical characteristics	7
4.1	AC operation	7
4.2	DC operation	7
4.3	Timing diagram	8
5	Bootstrap driver	9
	C _{BOOT} selection and charging	9
6	Typical characteristic	11
7	Package information	13
7.1	DIP-8 package information	13
7.2	SO-8 package information	15
8	Order codes	17
9	Revision history	17

2 Electrical data

2.1 Absolute maximum ratings

Table 1. Absolute maximum ratings

Symbol	Parameter	Value	Unit
V _{OUT}	Output voltage	-3 to V _{BOOT} -18	V
V _{CC}	Supply voltage ⁽¹⁾	- 0.3 to 14.6	V
I _s	Supply current ⁽¹⁾	25	mA
V _{BOOT}	Floating supply voltage	-1 to 618	V
V _{hvg}	High-side gate output voltage	-1 to V _{BOOT}	V
V _{lvg}	Low-side gate output voltage	-0.3 to V _{CC} +0.3	V
V _i	Logic input voltage	-0.3 to V _{CC} +0.3	V
V _{SD}	Shutdown/deadtime voltage	-0.3 to V _{CC} +0.3	V
dV _{out} /dt	Allowed output slew rate	50	V/ns
P _{tot}	Total power dissipation (T _j = 85 °C)	750	mW
T _J	Junction temperature	150	°C
T _s	Storage temperature	-50 to 150	°C
ESD	Human body model	2	kV

1. The device has an internal clamping Zener between GND and the V_{CC} pin, it must not be supplied by a low impedance voltage source.

2.2 Thermal data

Table 2. Thermal data

Symbol	Parameter	SO-8	DIP-8	Unit
R _{th(JA)}	Thermal resistance junction to ambient	150	100	°C/W

2.3 Recommended operating conditions

Table 3. Recommended operating conditions

Symbol	Pin	Parameter	Test condition	Min.	Typ.	Max.	Unit
V_{OUT}	6	Output voltage		(1)		580	V
$V_{BS}^{(2)}$	8	Floating supply voltage		(1)		17	V
f_{sw}		Switching frequency	HVG, LVG load $C_L = 1$ nF			400	kHz
V_{CC}	2	Supply voltage				V_{clamp}	V
T_j		Junction temperature		-45		125	°C

1. If the condition $V_{BOOT} - V_{OUT} < 18$ V is guaranteed, V_{OUT} can range from -3 to 580 V.
2. $V_{BS} = V_{BOOT} - V_{OUT}$.

3 Pin connection

Figure 2. Pin connection (top view)

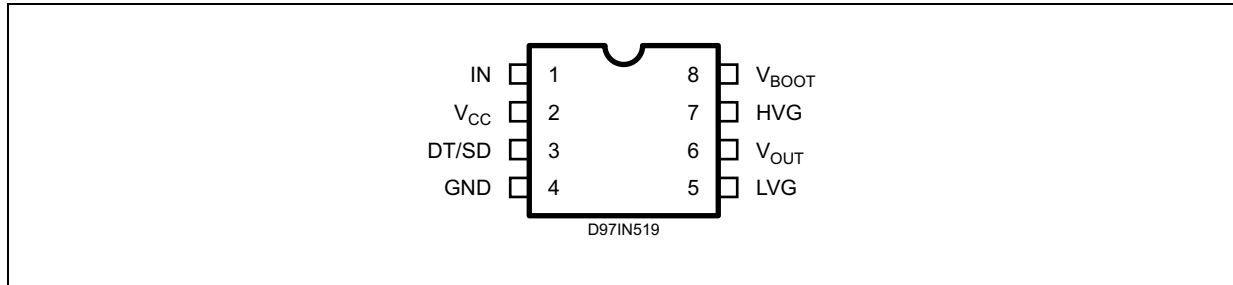

Table 4. Pin description

No.	Pin	Type	Function
1	IN	I	Logic input: it is in phase with HVG and in opposition of phase with LVG. It is compatible to V _{CC} voltage. ($V_{il\ Max} = 1.5\ V$, $V_{ih\ Min} = 3.6\ V$).
2	V _{CC}	P	Supply input voltage: there is an internal clamp [typ. 15.6 V].
3	DT/SD	I	High impedance pin with two functionalities. When pulled lower than V _{dt} (typ. 0.5 V), the device is shut down. A voltage higher than V _{dt} sets the deadtime between the high-side gate driver and low-side gate driver. The deadtime value can be set forcing a certain voltage level on the pin or connecting a resistor between the pin 3 and ground. Care must be taken to avoid below threshold spikes on the pin 3 that can cause undesired shutdown of the IC. For this reason the connection of the components between the pin 3 and ground has to be as short as possible. This pin can not be left floating for the same reason. The pin has not be pulled through a low impedance to V _{CC} , because of the drop on the current source that feeds R _{dt} . The operative range is: V _{dt} ... 270 KΩ · I _{dt} , that allows a dt range of 0.4 - 3.1 μs.
4	GND	P	Ground
5	LVG	O	Low-side driver output: the output stage can deliver 400 mA source and 650 mA sink (typ. values). The circuit guarantees 0.3 V max. on the pin (at I _{sink} = 10 mA) with V _{CC} > 3 V and lower than the turn-on threshold. This allows to omit the bleeder resistor connected between the gate and the source of the external MOSFET normally used to hold the pin low; the gate driver ensures low impedance also in SD conditions.
6	V _{OUT}	P	High-side driver floating reference: layout care has to be taken to avoid below ground spikes on this pin.
7	HVG	O	High-side driver output: the output stage can deliver 400 mA source and 650 mA sink (typ. values). The circuit guarantees 0.3 V max. between this pin and V _{OUT} (at I _{sink} = 10 mA) with V _{CC} > 3 V and lower than the turn-on threshold. This allows to omit the bleeder resistor connected between the gate and the source of the external MOSFET normally used to hold the pin low; the gate driver ensures low impedance also in SD conditions.
8	V _{BOOT}	P	Bootstrap supply voltage: it is the high-side driver floating supply. The bootstrap capacitor connected between this pin and the pin 6 can be fed by an internal structure named "bootstrap driver" (a patented structure). This structure can replace the external bootstrap diode.

4 Electrical characteristics

4.1 AC operation

Table 5. AC operation electrical characteristics ($V_{CC} = 14.4\text{ V}$; $T_J = 25\text{ }^\circ\text{C}$)

Symbol	Pin	Parameter	Test condition	Min.	Typ.	Max.	Unit
t_{on}	1 vs. 5, 7	High/low-side driver turn-on propagation delay	$V_{OUT} = 0\text{ V}$ $R_{dt} = 47\text{ k}\Omega$		200+ dt		ns
t_{onsd}	3 vs. 5, 7	Shutdown input propagation delay			220	280	ns
t_{off}	1 vs. 5, 7	High/low-side driver turn-off propagation delay	$V_{OUT} = 0\text{ V}$ $R_{dt} = 47\text{ k}\Omega$		250	300	ns
			$V_{OUT} = 0\text{ V}$ $R_{dt} = 146\text{ k}\Omega$		200	250	ns
			$V_{OUT} = 0\text{ V}$ $R_{dt} = 270\text{ k}\Omega$		170	200	ns
t_r	5, 7	Rise time	$C_L = 1000\text{ pF}$		50		ns
t_f	5, 7	Fall time	$C_L = 1000\text{ pF}$		30		ns

4.2 DC operation

Table 6. DC operation electrical characteristics ($V_{CC} = 14.4\text{ V}$; $T_J = 25\text{ }^\circ\text{C}$)

Symbol	Pin	Parameter	Test condition	Min.	Typ.	Max.	Unit
Supply voltage section							
V_{clamp}	2	Supply voltage clamping	$I_s = 5\text{ mA}$	14.6	15.6	16.6	V
V_{CCth1}	2	V_{CC} UV turn-on threshold		11.5	12	12.5	V
V_{CCth2}	2	V_{CC} UV turn-off threshold		9.5	10	10.5	V
V_{CCchys}		V_{CC} UV hysteresis			2		V
I_{QCCU}		Undervoltage quiescent supply current	$V_{CC} \leq 11\text{ V}$		150		μA
I_{QCC}		Quiescent current	$V_{IN} = 0$		380	500	μA
Bootstrapped supply voltage section							
V_{BOOT}	8	Bootstrap supply voltage				17	V
I_{QBS}		Quiescent current	IN = HIGH			100	μA
I_{LK}		High voltage leakage current	$V_{hvg} = V_{OUT} = V_{BOOT} = 600\text{ V}$			10	μA
R_{dson}		Bootstrap driver on-resistance ⁽¹⁾	$V_{CC} \geq 12.5\text{ V}$; IN = LOW		125		Ω
High/low-side driver							
I_{so}	5, 7	Source short-circuit current	$V_{IN} = V_{ih}$ ($t_p < 10\text{ }\mu\text{s}$)	300	400		mA
I_{si}		Sink short-circuit current	$V_{IN} = V_{il}$ ($t_p < 10\text{ }\mu\text{s}$)	500	650		mA

Table 6. DC operation electrical characteristics (continued) ($V_{CC} = 14.4\text{ V}$; $T_J = 25\text{ }^\circ\text{C}$)

Symbol	Pin	Parameter	Test condition	Min.	Typ.	Max.	Unit
Logic inputs							
V_{il}	1, 3	Low level logic threshold voltage				1.5	V
V_{ih}		High level logic threshold voltage		3.6			V
I_{ih}		High level logic input current	$V_{IN} = 15\text{ V}$		50	70	μA
I_{il}		Low level logic input current	$V_{IN} = 0\text{ V}$			1	μA
I_{ref}	3	Deadtime setting current			28		μA
dt	3 vs. 5, 7	Deadtime setting range ⁽²⁾	$R_{dt} = 47\text{ k}\Omega$ $R_{dt} = 146\text{ k}\Omega$ $R_{dt} = 270\text{ k}\Omega$	0.4	0.5 1.5 2.7	3.1	μs μs μs
V_{dt}	3	Shutdown threshold			0.5		V

1. $R_{DS(on)}$ is tested in the following way:

$$R_{DS(on)} = \frac{(V_{CC} - V_{BOOT1}) - (V_{CC} - V_{BOOT2})}{I_1(V_{CC}, V_{BOOT1}) - I_2(V_{CC}, V_{BOOT2})}$$

Where I_1 is the pin 8 current when $V_{BOOT} = V_{BOOT1}$, I_2 when $V_{BOOT} = V_{BOOT2}$.

2. The pin 3 is a high impedance pin. Therefore dt can be set also forcing a certain voltage V_3 on this pin. The deadtime is the same obtained with an R_{dt} if it is: $R_{dt} \times I_{ref} = V_3$.

4.3 Timing diagram

Figure 3. Input/output timing diagram

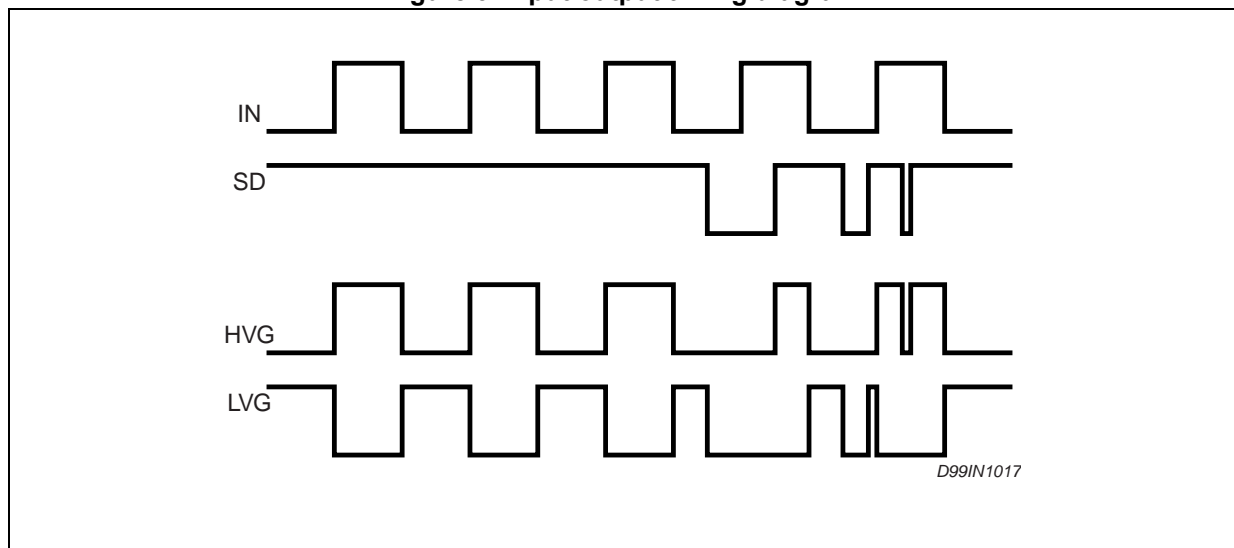

5 Bootstrap driver

A bootstrap circuitry is needed to supply the high voltage section. This function is normally accomplished by a high voltage fast recovery diode (*Figure 4 a*). In the L6384E device a patented integrated structure replaces the external diode. It is realized by a high voltage DMOS, driven synchronously with the low-side driver (LVG), with a diode in series, as shown in *Figure 4 b*. An internal charge pump (*Figure 4 b*) provides the DMOS driving voltage. The diode connected in series to the DMOS has been added to avoid undesirable turn-on.

C_{BOOT} selection and charging

To choose the proper C_{BOOT} value the external MOSFET can be seen as an equivalent capacitor. This capacitor C_{EXT} is related to the MOSFET total gate charge:

Equation 1

$$C_{EXT} = \frac{Q_{gate}}{V_{gate}}$$

The ratio between the capacitors C_{EXT} and C_{BOOT} is proportional to the cyclical voltage loss. It has to be:

$$C_{BOOT} \gg C_{EXT}$$

E.g.: if Q_{gate} is 30 nC and V_{gate} is 10 V, C_{EXT} is 3 nF. With $C_{BOOT} = 100$ nF the drop would be 300 mV.

If HVG has to be supplied for a long time, the C_{BOOT} selection has to take into account also the leakage losses.

E.g.: HVG steady state consumption is lower than 100 μ A, so if HVG T_{ON} is 5 ms, C_{BOOT} has to supply 0.5 μ C to C_{EXT} . This charge on a 1 μ F capacitor means a voltage drop of 0.5 V.

The internal bootstrap driver gives great advantages: the external fast recovery diode can be avoided (it usually has a great leakage current).

This structure can work only if V_{OUT} is close to GND (or lower) and in the meanwhile the LVG is on. The charging time (T_{charge}) of the C_{BOOT} is the time in which both conditions are fulfilled and it has to be long enough to charge the capacitor.

The bootstrap driver introduces a voltage drop due to the DMOS R_{DSON} (typical value: 125 Ω). At low frequency this drop can be neglected. Anyway increasing the frequency it must be taken in to account.

The following equation is useful to compute the drop on the bootstrap DMOS:

Equation 2

$$V_{drop} = I_{charge} R_{dson} \rightarrow V_{drop} = \frac{Q_{gate}}{T_{charge}} R_{dson}$$

where Q_{gate} is the gate charge of the external power MOSFET, R_{dson} is the on-resistance of the bootstrap DMOS, and T_{charge} is the charging time of the bootstrap capacitor.

For example: using a power MOSFET with a total gate charge of 30 nC, the drop on the bootstrap DMOS is about 1 V, if the T_{charge} is 5 μs . In fact:

Equation 3

$$V_{drop} = \frac{30nC}{5\mu s} \cdot 125\Omega \sim 0.8V$$

V_{drop} has to be taken into account when the voltage drop on C_{BOOT} is calculated: if this drop is too high, or the circuit topology doesn't allow a sufficient charging time, an external diode can be used.

Figure 4. Bootstrap driver

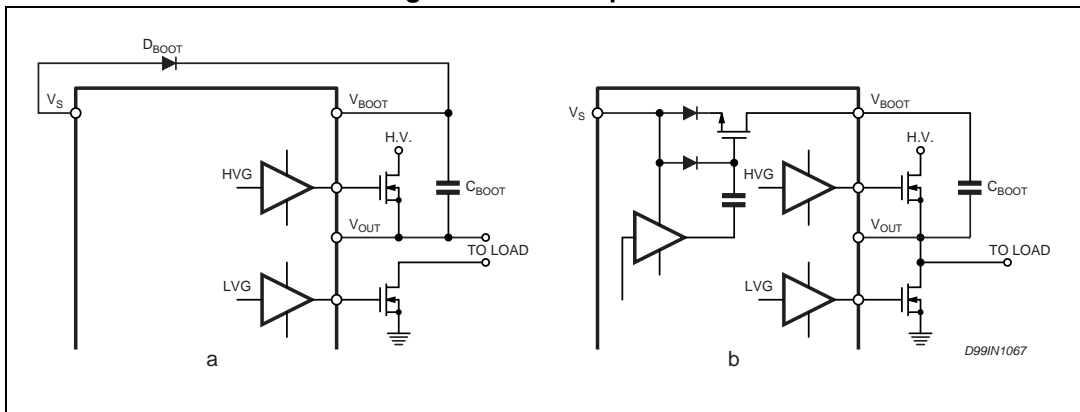

6 Typical characteristic

Figure 5. Typical rise and fall times vs. load capacitance

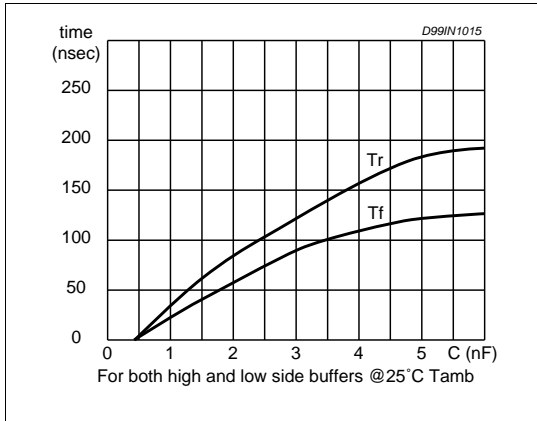

Figure 6. Quiescent current vs. supply voltage

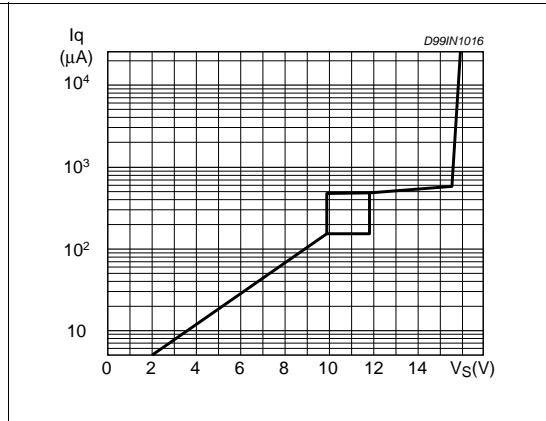

Figure 7. Deadtime vs. resistance

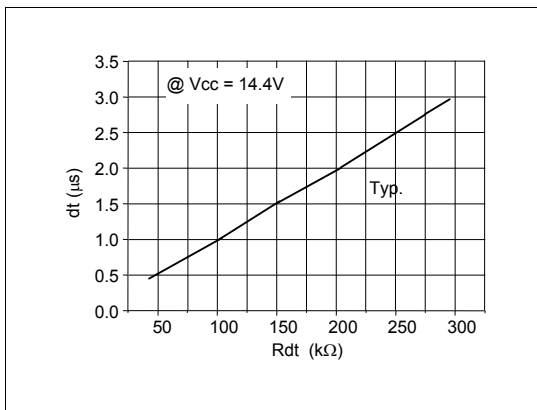

Figure 8. Driver propagation delay vs. temperature

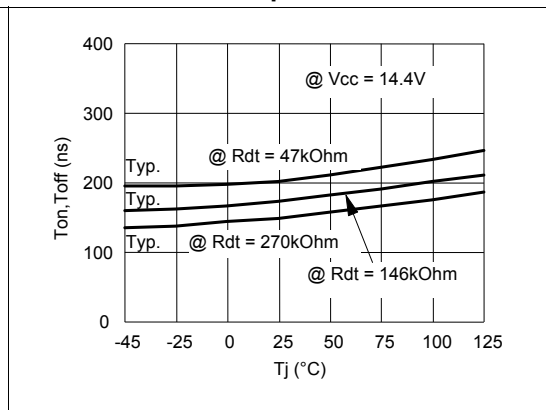

Figure 9. Deadtime vs. temperature

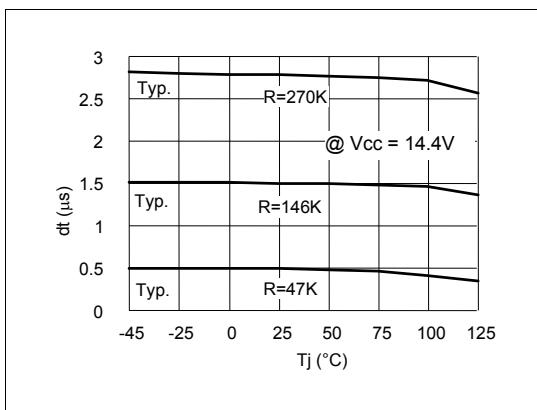

Figure 10. Shutdown threshold vs. temperature

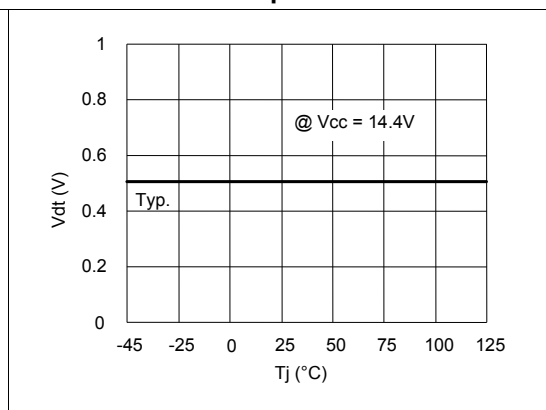

Figure 11. V_{CC} UV turn-on vs. temperature

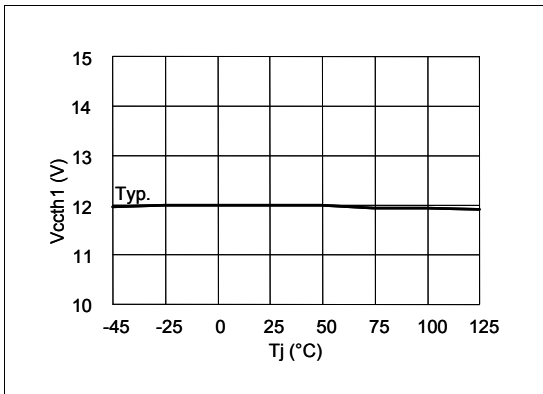

Figure 12. Output source current vs. temperature

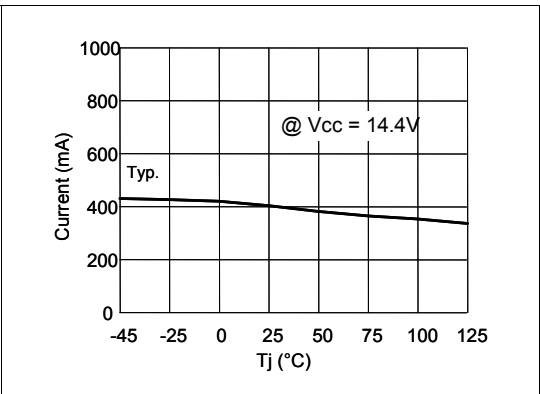

Figure 13. V_{CC} UV turn-off vs. temperature

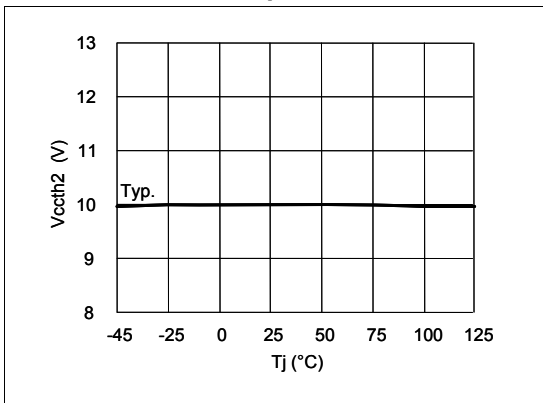
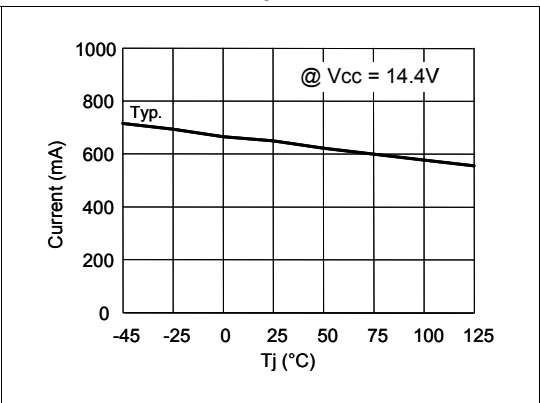

Figure 14. Output sink current vs. temperature



7 Package information

In order to meet environmental requirements, ST offers these devices in different grades of ECOPACK® packages, depending on their level of environmental compliance. ECOPACK specifications, grade definitions and product status are available at: www.st.com. ECOPACK is an ST trademark.

7.1 DIP-8 package information

Figure 15. DIP-8 package outline

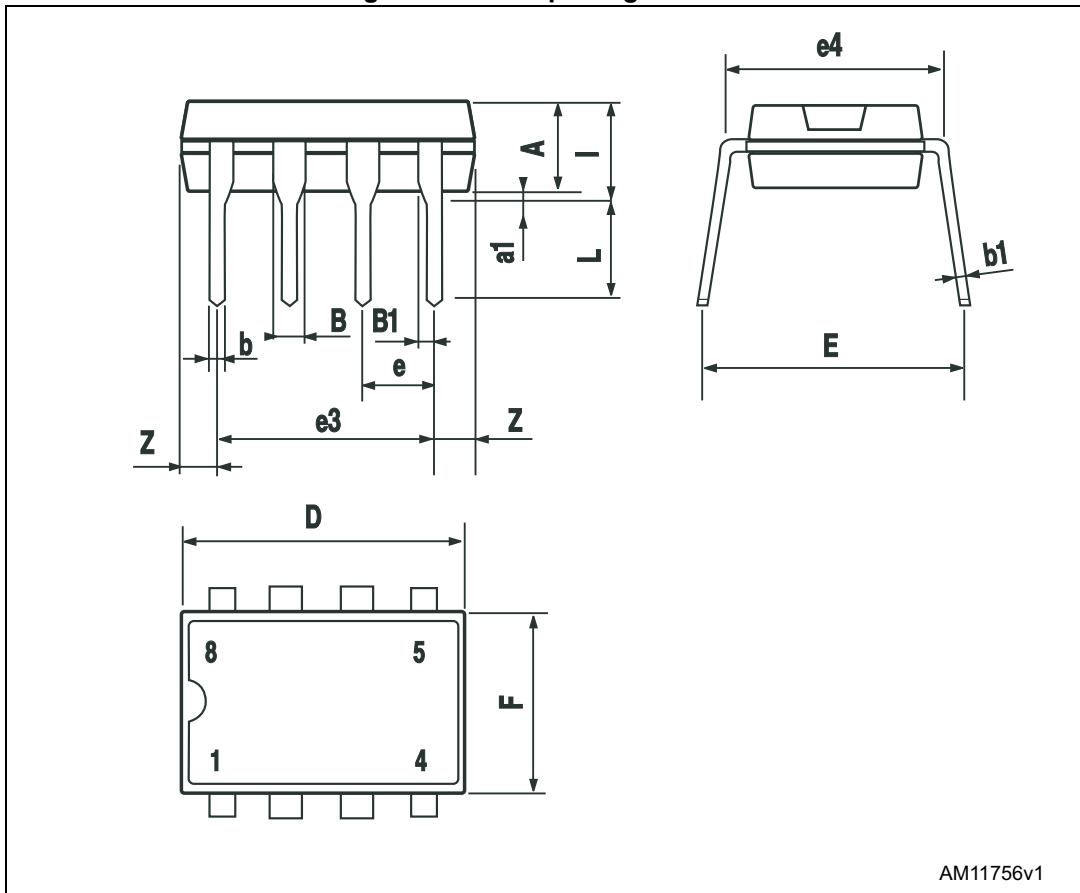

Table 7. DIP-8 package mechanical data

Symbol	Dimensions (mm)			Dimensions (inch)		
	Min.	Typ.	Max.	Min.	Typ.	Max.
A		3.32			0.131	
a1	0.51			0.020		
B	1.15		1.65	0.045		0.065
b	0.356		0.55	0.014		0.022
b1	0.204		0.304	0.008		0.012
D			10.92			0.430
E	7.95		9.75	0.313		0.384
e		2.54			0.100	
e3		7.62			0.300	
e4		7.62			0.300	
F			6.6			0.260
I			5.08			0.200
L	3.18		3.81	0.125		0.150
Z			1.52			0.060

7.2 SO-8 package information

Figure 16. SO-8 package outline

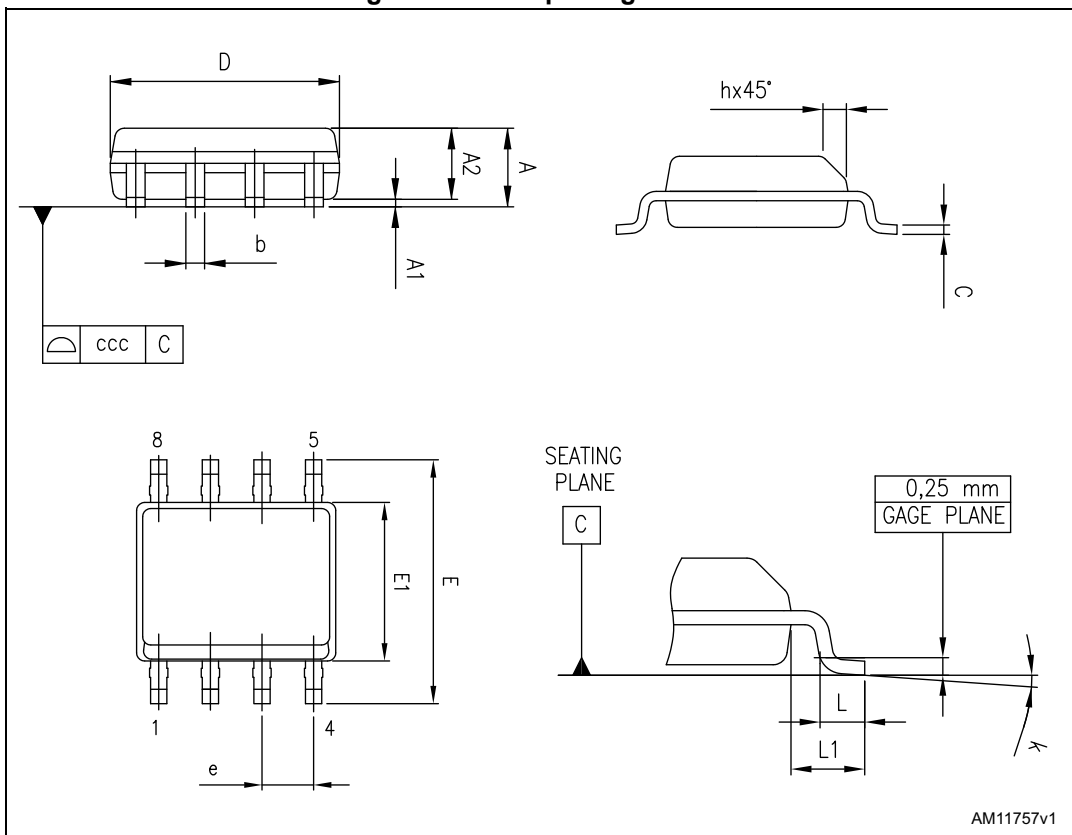

Table 8. SO-8 package mechanical data

Symbol	Dimensions (mm)			Dimensions (inch)		
	Min.	Typ.	Max.	Min.	Typ.	Max.
A			1.750			0.0689
A1	0.100		0.250	0.0039		0.0098
A2	1.250			0.0492		
b	0.280		0.480	0.0110		0.0189
c	0.170		0.230	0.0067		0.0091
D ⁽¹⁾	4.800	4.900	5.000	0.1890	0.1929	0.1969
E	5.800	6.000	6.200	0.2283	0.2362	0.2441
E1 ⁽²⁾	3.800	3.900	4.000	0.1496	0.1535	0.1575
e		1.270			0.0500	
h	0.250		0.500	0.0098		0.0197
L	0.400		1.270	0.0157		0.0500
L1		1.040			0.0409	
k	0°		8°	0°		8°
ccc			0.100			0.0039

1. Dimension "D" does not include mold flash, protrusions or gate burrs. Mold flash, protrusions or gate burrs shall not exceed 0.15 mm in total (both sides).
2. Dimension "E1" does not include interlead flash or protrusions. Interlead flash or protrusions shall not exceed 0.25 mm per side.

8 Order codes

Table 9. Order code

Order code	Package	Packaging
L6384E	DIP-8	Tube
L6384ED	SO-8	Tube
L6384ED013TR	SO-8	Tape and reel

9 Revision history

Table 10. Document revision history

Date	Revision	Changes
12-Oct-2007	1	First release
20-Jun-2014	2	<p>Added Section : Applications on page 1.</p> <p>Updated Section : Description on page 1 (replaced by new description).</p> <p>Updated Table 1: Device summary on page 1 (moved from page 15 to page 1, updated title).</p> <p>Updated Figure 1: Block diagram on page 3 (moved from page 1 to page 3, numbered and added title to Section 1: Block diagram on page 3).</p> <p>Updated Section 2.1: Absolute maximum ratings on page 4 (removed note below Table 2: Absolute maximum ratings).</p> <p>Updated Table 5: Pin description on page 5 (updated "Type" of several pins).</p> <p>Updated Table 7 on page 6 (updated "Max." value of I_{QBS} symbol).</p> <p>Updated Section : C_{BOOT} selection and charging on page 8 (updated values of "E.g.: HVG").</p> <p>Numbered Equation 1 on page 8, Equation 2 on page 8 and Equation 3 on page 9.</p> <p>Updated Section 7: Package information on page 12 [updated/added titles, updated ECOPACK text, reversed order of Figure 15 and Table 8, Figure 16 and Table 9 (numbered tables), removed 3D package figures, minor modifications].</p> <p>Minor modifications throughout document.</p>
16-Sep-2015	3	<p>Updated Table 1 on page 4 (added ESD parameter and value, minor modifications).</p> <p>Updated note 1. below Table 6 on page 7 (replaced V_{CBOOTx} by V_{BOOTx}).</p> <p>Moved Table 9 on page 17 (moved from page 1 to page 17, updated titles).</p> <p>Updated cross-references throughout document.</p> <p>Minor modifications throughout document.</p>

IMPORTANT NOTICE – PLEASE READ CAREFULLY

STMicroelectronics NV and its subsidiaries (“ST”) reserve the right to make changes, corrections, enhancements, modifications, and improvements to ST products and/or to this document at any time without notice. Purchasers should obtain the latest relevant information on ST products before placing orders. ST products are sold pursuant to ST’s terms and conditions of sale in place at the time of order acknowledgement.

Purchasers are solely responsible for the choice, selection, and use of ST products and ST assumes no liability for application assistance or the design of Purchasers’ products.

No license, express or implied, to any intellectual property right is granted by ST herein.

Resale of ST products with provisions different from the information set forth herein shall void any warranty granted by ST for such product.



ST and the ST logo are trademarks of ST. All other product or service names are the property of their respective owners.

Information in this document supersedes and replaces information previously supplied in any prior versions of this document.

© 2015 STMicroelectronics – All rights reserved

Looking for pricing, stock, or lifecycle information?

Click below to explore more details on WIN SOURCE:

-  [View L6384E on WIN SOURCE](#)
-  [STMicroelectronics Information](#)

Optimize Your Supply Chain with WIN SOURCE Solutions

-  Global Sourcing Solution
-  Obsolete Management
-  Cost Control Management
-  Shortage Management
-  Alternative Solution
-  Excess Inventory Management