



**THE DATASHEET OF  
L6370D013TR**



## 2.5 A high-side driver industrial intelligent power switch

### Features

- 2.5 A output current
- 9.5 V to 35 V supply voltage range
- Internal current limiting
- Thermal shutdown
- Open ground protection
- Internal negative voltage clamping to  $V_S - 50$  V for fast demagnetization
- Differential inputs with large common mode range and threshold hysteresis
- Undervoltage lockout with hysteresis
- Open load detection
- Two diagnostic outputs
- Output status led driver
- Non dissipative short circuit protection
- Protection against and surge transient (IEC 61000-4-5)
- Immunity against burst transient (IEC 61000-4-4)
- ESD protection (human body model  $\pm 2$  kV)

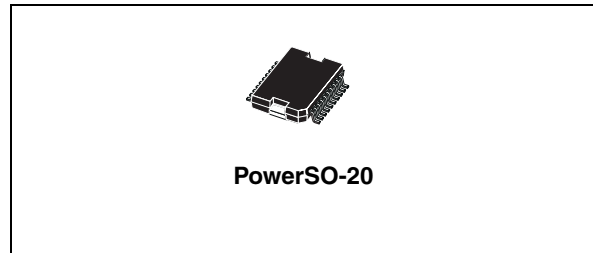

### Description

The L6370 is a monolithic intelligent power switch in Multipower-BCD Technology, for driving inductive or resistive loads. An internal clamping diode enables the fast demagnetization of inductive loads. Diagnostic for CPU feedback and extensive use of electrical protections make this device extremely rugged and specially suitable for industrial automation applications.

**Table 1. Device summary**

Part number	Op. temp. range, °C	Package	Packaging
L6370D	-25 to +85	PowerSO-20	Tube
L6370D013TR	-25 to +85	PowerSO-20	Tape and reel

# Contents

- 1      Block diagram and pin description ..... 3**
  - 1.1   Pin description ..... 4
  
- 2      Electrical specifications ..... 5**
  - 2.1   Absolute maximum ratings ..... 5
  - 2.2   Thermal data ..... 5
  - 2.3   Electrical characteristics ..... 6
  - 2.4   AC operation ..... 7
  
- 3      Circuit description ..... 8**
  - 3.1   Diagnostic truth table ..... 9
  - 3.2   Input section ..... 9
  - 3.3   Diagnostic logic ..... 9
  - 3.4   Short circuit operation ..... 10
  - 3.5   Overtemperature protection (OVT) ..... 10
  - 3.6   Undervoltage protection (UV) ..... 10
  - 3.7   Demagnetization of inductive loads ..... 11
  
- 4      Package mechanical data ..... 12**
  - 4.1   PowerSO-20 mechanical data and package dimensions ..... 13
  - 4.2   PowerSO-20 packing information ..... 14
  
- 5      Revision history ..... 17**

# 1 Block diagram and pin description

Figure 1. Block diagram

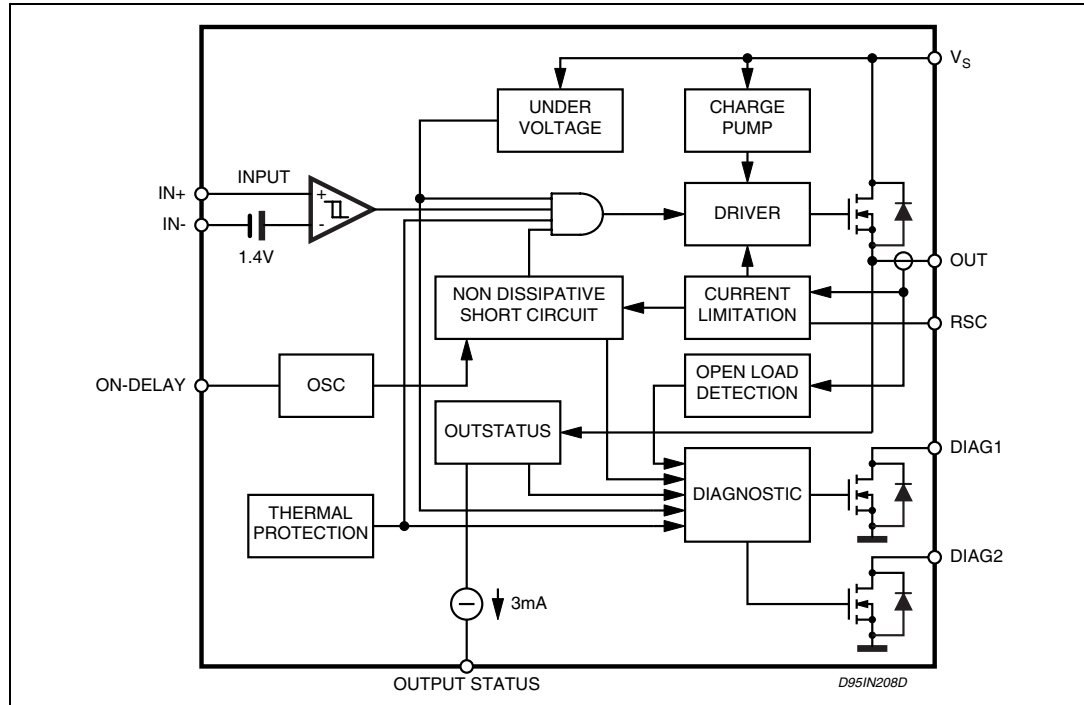
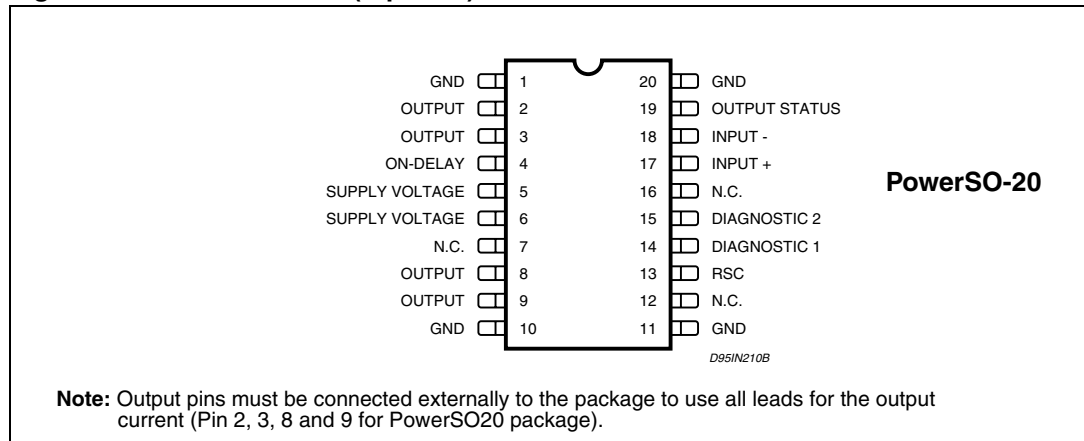

Figure 2. Pin connection (top view)



## 1.1 Pin description

**Table 2. Pin description**

Pin N°	Pin name	Function
14	DIAG1	DIAGNOSTIC 1 output. This open drain reports the IC working conditions. (See diagnostic truth <a href="#">Table 7</a> )
15	DIAG2	DIAGNOSTIC 2 output. This open drain reports the IC working conditions. (See diagnostic truth <a href="#">Table 7</a> )
18	IN-	Comparator non inverting input
17	IN+	Comparator inverting input
19	OUTSTATUS	This current source output is capable of driving a LED to signal the status of the output pin. The pin is active (source current) when the output pin is considered high (See <a href="#">Figure 3</a> )
1, 10, 11, 20	GND	Ground
4	ON-DELAY	Programmable ON time interval duration during short circuit operation
13	RSC	Current limitation setting.
8, 9	OUTPUT	High side output with built-in current limitation
5, 6	V <sub>S</sub>	Supply Voltage Input, the value of the supply voltage is monitored to detect under voltage condition

## 2 Electrical specifications

### 2.1 Absolute maximum ratings

**Table 3. Absolute maximum ratings**

Symbol	Parameter	Value	Unit
$V_S$	Supply voltage ( $T_W < 10\text{ms}$ )	50	V
$V_S - V_O$	Supply to output differential voltage. See also $V_{CI}$	internally limited	V
$V_{od}$	Externally forced voltage	-0.3 to 7	V
$I_{od}$	Externally forced current	$\pm 1$	mA
$V_i$	Input voltage	-10 to $V_S + 10$	V
$V_i$	Differential input voltage	43	V
$I_i$	Input current	20	mA
$I_O$	Output current. see also ISC	internally limited	A
$P_{TOT}$	Power dissipation. see also thermal characteristics.	internally limited	W
$T_{OP}$	Operating temperature range ( $T_{amb}$ )	-25 to +85	$^{\circ}\text{C}$
$T_{STG}$	Storage temperature	-55 to 150	$^{\circ}\text{C}$
$E_I$	Energy induct. load $T_J = 85^{\circ}\text{C}$	1	J

### 2.2 Thermal data

**Table 4. Thermal data**

Symbol	Description		Value	Unit
$R_{thJC}$	Thermal resistance junction to case	Max.	1.5	$^{\circ}\text{C}/\text{W}$
$R_{thJA}$	Thermal resistance junction to ambient	Max.	-	

### 2.3 Electrical characteristics

( $V_S = 24V$ ;  $T_J = -25$  to  $+125^\circ C$ , unless otherwise specified)

**Table 5. Electrical characteristics**

Symbol	Parameter	Test condition	Min.	Typ.	Max.	Unit
$V_{smin}$	Supply voltage for valid diagnostics	$I_{diag} > 0.5mA$ ; $V_{dg1} = 1.5V$	4		35	V
$V_s$	Supply voltage (operative)		9.5	24	35	V
$I_q$	Quiescent current $I_{out} = I_{os} = 0$	$V_{il}$ $V_{ih}$		0.8 3	1.4 4	mA
$V_{sth1}$	Undervoltage threshold 1	(See <i>Figure 4</i> ), $T_{amb} = 0$ to $+85^\circ C$	8.5	9	9.5	V
$V_{sth2}$	Undervoltage threshold 2		8	8.5	9	V
$V_{sth3}$	Supply voltage hysteresis		300	500	700	mV
$I_{sc}$	Short circuit current	$V_S = 9.5$ to $35V$ ; $R_L = 2\Omega$ $5k\Omega < R_{SC} < 30k\Omega$	15/ $R_{SC}(k\Omega)$			A
		$0 < R_{SC} < 5k\Omega$	2.6	3.2	4	A
$V_{don}$	Output voltage drop	$I_{out} = 2.0A$ , $T_j = 25^\circ C$ $T_j = 125^\circ C$		200 320	280 440	mV
		$I_{out} = 2.5A$ , $T_j = 25^\circ C$ $T_j = 125^\circ C$		250 400	350 550	mV
$I_{oslk}$	Output leakage current	$V_i = V_{il}$ ; $V_o = 0V$			500	$\mu A$
$V_{ol}$	Low state out voltage	$V_i = V_{il}$ ; $R_L = \infty$		0.8	1.5	V
$V_{cl}$	Internal voltage clamp ( $V_S - V_O$ )	$I_O = 1A$ Single pulsed: $T_p = 300 \mu s$	48	53	58	V
$I_{old}$	Open load detection current	$V_i = V_{ih}$ ; $T_{amb} = 0$ to $+85^\circ C$	1	3	6	mA
$V_{id}$	Common mode input voltage range (operative)	$V_S = 18$ to $35V$	-7		15	V
$I_{ib}$	Input bias current	$V_i = -7$ to $15V$ ; $-I_n = 0V$	-250		250	$\mu A$
$V_{ith}$	Input threshold voltage	$V + I_n > V - I_n$	0.8	1.4	2	V
$V_{iths}$	Input threshold hysteresis voltage	$V + I_n > V - I_n$	50		400	mV
$R_{id}$	Diff. input resistance	$0 < +I_n < +16V$ ; $-I_n = 0V$ $-7 < +I_n < 0V$ ; $-I_n = 0V$		400 150		$K\Omega$
$I_{ilk}$	Input offset current	$V + I_n = V - I_n$ +li $0V < V_i < 5.5V$ -li	-20 -75		+20	$\mu A$
		$-I_n = GND$ +li $0V < V + I_n < 5.5V$ -li	-250	+10 -125	+50	
		$+I_n = GND$ +li $0V < V - I_n < 5.5V$ -li	-100 -50	-30 -15		

Table 5. Electrical characteristics (continued)

Symbol	Parameter	Test condition	Min.	Typ.	Max.	Unit
$V_{oth1}$	Output status threshold 1 voltage	(See Figure 3)	4.5	5	5.5	V
$V_{oth2}$	Output status threshold 2 voltage		4	4.5	5.0	V
$V_{ohys}$	Output status threshold hysteresis		300	500	700	mV
$I_{osd}$	Output status source current	$V_{out} > V_{oth1}$ ; $V_{os} = 2.5V$	2		4	mA
$V_{osd}$	Active output status driver drop voltage	$V_S - V_{os}$ ; $I_{os} = 2mA$ $T_{amb} = 0$ to $+85^{\circ}C$		1.5	3	V
$I_{oslk}$	Output status driver leakage current	$V_{out} < V_{oth2}$ ; $V_{os} = 0V$ $V_S = 9.5$ to $35V$			25	$\mu A$
$V_{dgl}$	Diagnostic drop voltage	D1 / D2 = L; $I_{diag} = 0.5mA$ D1 / D2 = L; $I_{diag} = 3mA$		40 250		mV
$I_{dglk}$	Diagnostic leakage current	D1 / D2 = H; $0 < V_{dgl} < V_S$ $V_S = 9.5$ to $35V$			5	$\mu A$
<b>Source drain NDMOS diode</b>						
$V_{fSD}$	Forward on voltage	@ $I_{fSD} = 2.5A$		1	1.5	V
$I_{fp}$	Forward peak current	$t = 10ms$ ; $d = 20\%$			6	A
$t_{rr}$	Reverse recovery time	$I_f = 2.5A$ $di/dt = 25A/\mu s$		200		ns
$t_{fr}$	Forward recovery time			100		ns
<b>Thermal characteristics</b>						
$\Theta_{Lim}$	Junction temp. protect.		135	150		$^{\circ}C$
$\Theta_{TH}$	Thermal hysteresis			20		$^{\circ}C$

Note:  $V_{il} \leq 0.8V$ ,  $V_{ih} \geq 2V$  @ ( $V+In > V-In$ )

## 2.4 AC operation

Table 6. AC operation

Symbol	Parameter	Test condition	Min.	Typ.	Max.	Unit
$t_r - t_f$	Rise or fall time	$V_S = 24V$ ; $R_1 = 70\Omega$ ; $R_1$ to ground		20		$\mu s$
$t_d$	Delay time			5		$\mu s$
dV/dt	Slew rate (rise and fall edge)		0.7	1	1.5	V/ $\mu s$
$t_{ON}$	On time during short circuit condition	$50pF < C_{DON} < 2nF$		1.28		$\mu s/pF$
$t_{OFF}$	Of time during short circuit condition			64		$t_{ON}$
$f_{max}$	Maximum operating frequency			25		KHz

### 3 Circuit description

Figure 3. Output status hysteresis

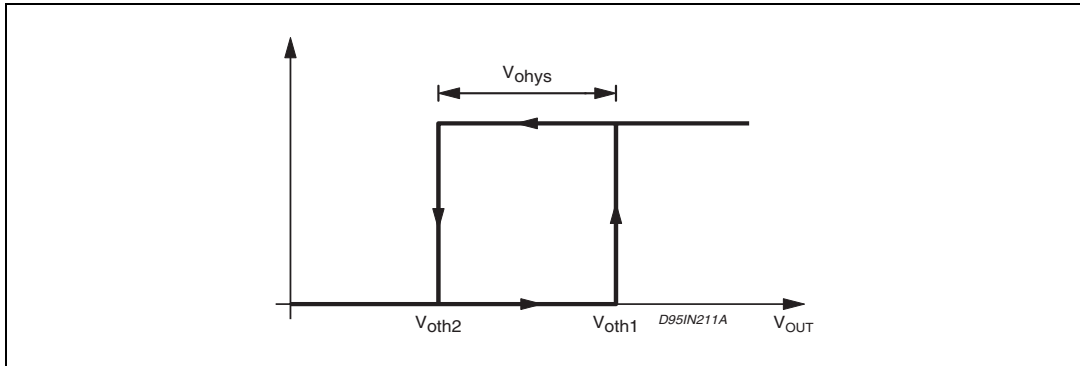

Figure 4. Undervoltage comparator hysteresis

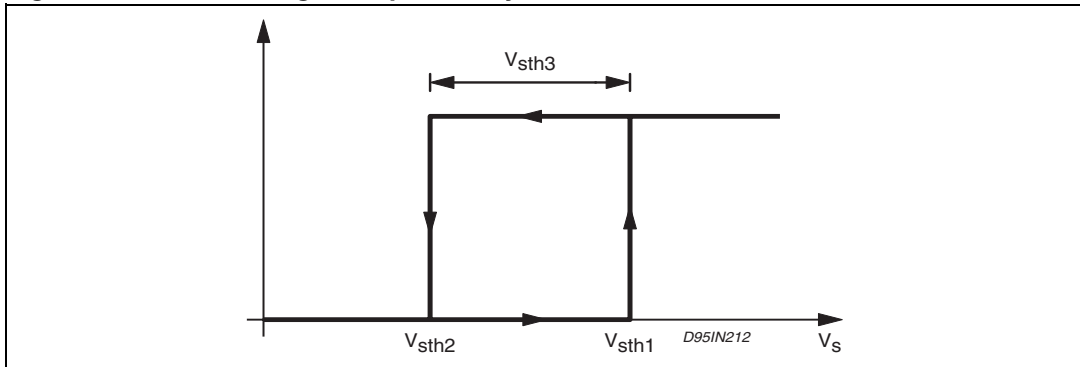
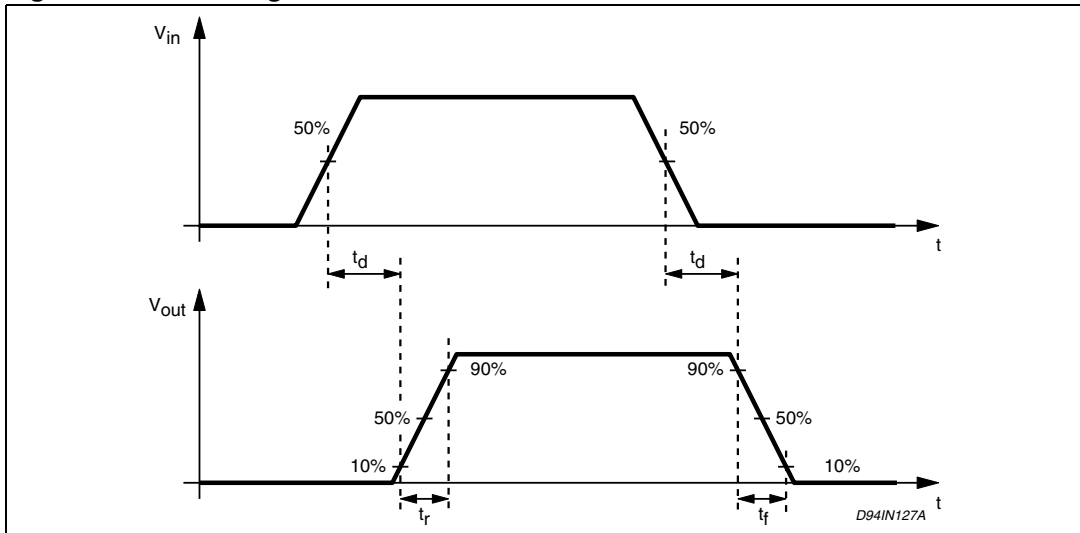

Figure 5. Switching waveforms



### 3.1 Diagnostic truth table

Table 7. Diagnostic truth table

Diagnostic conditions	Input	Output	Diag1	Diag2
Normal operation	L	L	H	H
	H	H	H	H
Open load condition ( $I_o < I_{old}$ )	L	L	H	H
	H	H	L	H
Short to $V_S$	L	H	L	H
	H	H	L	H
Short circuit to ground ( $I_O = I_{SC}$ ) <sup>(1)</sup> (pin ON-DELAY grounded)	H	X	H	H
	L	L	H	H
Output DMOS open	L	L	H	H
	H	L	L	H
Overtemperature	L	L	H	L
	H	L	H	L
Supply undervoltage ( $V_S < V_{sth2}$ )	L	L	L	L
	H	L	L	L

1. A cold lamp filament, or a capacitive load may activate the current limiting circuit of the IPS, when the IPS is initially turned on.

### 3.2 Input section

The input section is an high impedance differential stage with high common and differential mode range. There's built-in offset of +1.4 V (typical value) and an hysteresis of 400 mV (maximum value), to ensure high noise immunity.

### 3.3 Diagnostic logic

The operating conditions of the device are permanently monitored and the following occurrences are signalled via the DIAG1/DIAG2 open-drain output pins:

- Short circuit versus ground. A current limiting circuit fixes at  $I_{SC} = 3.2$  A (typical value) the maximum current that can be sourced from the OUTPUT pin (for more details see short circuit operation section).
- Short circuit versus  $V_S$ .
- Under voltage (UV)
- Over temperature (OVT)
- Open load, if the output current is less than 3 mA (typical value).
- Output DMOS open according to the diagnostic truth [Table 7](#).

### 3.4 Short circuit operation

In order to minimize the power dissipation when the output is shorted to grounded, an innovative, non dissipative short circuit protection (patent pending) is implemented, avoiding, thus the intervention of the thermal protection in most cases.

Whenever the output is shorted to ground, or, generally speaking, an overcurrent is sink by the load, the output devices is driven in linear mode, sourcing the  $I_{sc}$  current (typically 3.2 A) for a time interval ( $t_{on}$ ) defined by means of the external  $C_{ON}$  capacitor connected between the ONDELAY pin and GND. Whether the short circuit crease within the  $t_{on}$  interval the DIAG2 output status is not affected, acting as a programmable diagnostic delay.

This function allow the device to drive a capacitive load or a filament lamp (that exhibits a very low resistance during the initial heading phase) without the intervention of the diagnostic. If the short circuit lasts for the whole  $t_{ON}$  interval, the output DMOS is switched OFF and the DIAG2 goes low, for a time interval  $t_{OFF}$  lasting 64 times  $t_{ON}$ .

At the end of the  $t_{OFF}$  interval if the short circuit condition is still present, the output DMOS is turned ON (and the DIAG2 goes high - see [Figure 7](#)) for another  $t_{ON}$  interval and the sequence starts again, or, whether not, the normal condition operation is resumed.

The  $t_{ON}$  interval can be set to lasts between 64 ms and 2.56 ms for a  $C_{ON}$  capacitor value ranging between 50 pF and 2 nF to have:

$$t_{ON} (\mu s) = 1.28 C_{ON} (pF)$$

If the ON-DELAY pin is grounded the non dissipative short circuit protection is disabled, and the  $I_{sc}$  current is delivered until the overtemperature protection shuts the device off. The behaviour of the DIAG2 output is, in this situation, showed in the Diagnostic Truth [Table 7](#).

### 3.5 Overtemperature protection (OVT)

If the chip temperature exceeds  $Q_{lim}$  (measured in a central position in the chip) the chip deactivates itself.

The following actions are taken:

all the output stage is switched off;

the signal DIAG2 is activated (active low).

Normal operation is resumed as soon as (typically after some seconds) the chip temperature monitored goes back below  $\Theta_{lim}-\Theta_H$ .

The different thresholds with hysteretic behavior assure that no intermittent conditions can be generated.

### 3.6 Undervoltage protection (UV)

The supply voltage is expected to range from 9.5 V to 35 V, even if its reference value is considered to be 24 V.

In this range the device operates correctly. Below 9.5 V the overall system has to be considered not reliable.

Protection will thus shut off the output whenever the supply voltage falls below the mask fixed by the  $V_{sth1}$  (9 V typ.) and  $V_{sth2}$  (8.5 V typ.).

The hysteresis (see [Figure 4](#)) ensures a non intermittent behavior at low supply voltage with a superimposed ripple. The under voltage status is signalled via the DIAG1 and DIAG2 outputs (see the Diagnostic Truth [Table 7](#)).

### 3.7 Demagnetization of inductive loads

An internal zener diode, limiting the voltage across the Power MOS to between 50 and 60 V ( $V_{ci}$ ), provides safe and fast demagnetization of inductive loads without external clamping devices. The maximum energy that can be absorbed from an inductive load is specified as 1J (at  $T_j = 85^\circ\text{C}$ ) (see [Table 3](#)).

**Figure 6. L6370 short circuit operation waveforms**

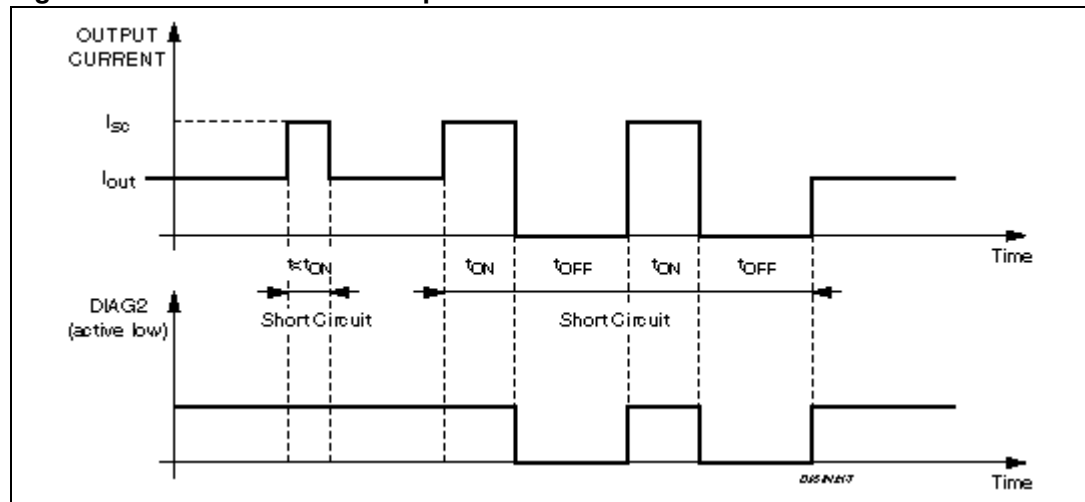

**Figure 7. Inductive load equivalent circuit**

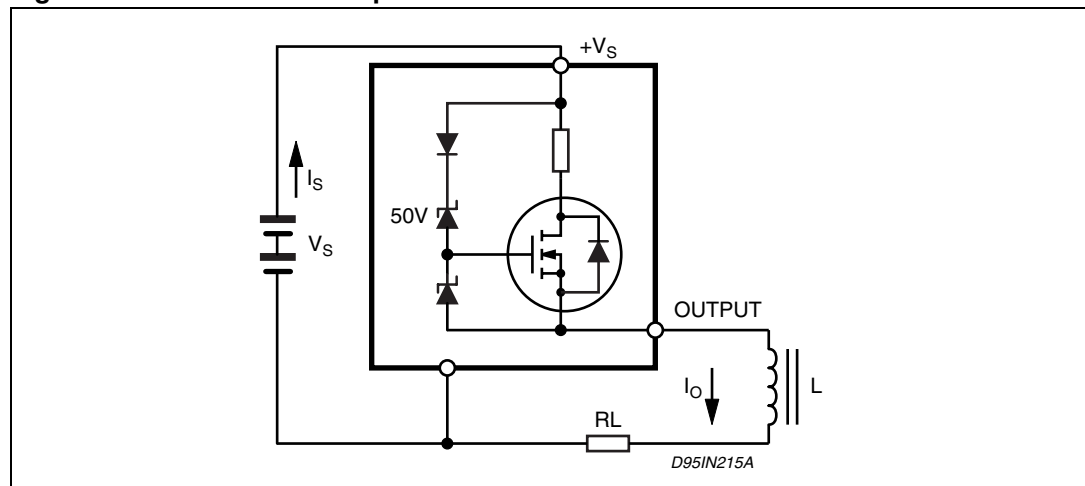

## 4 Package mechanical data

In order to meet environmental requirements, ST offers these devices in different grades of ECOPACK® packages, depending on their level of environmental compliance. ECOPACK® specifications, grade definitions and product status are available at: [www.st.com](http://www.st.com). ECOPACK® is an ST trademark.

### 4.1 PowerSO-20 mechanical data and package dimensions

Figure 8. PowerSO-20 mechanical data and package dimensions

DIM.	mm			inch		
	MIN.	TYP.	MAX.	MIN.	TYP.	MAX.
A			3.6			0.142
a1	0.1		0.3	0.004		0.012
a2			3.3			0.130
a3	0		0.1	0.000		0.004
b	0.4		0.53	0.016		0.021
c	0.23		0.32	0.009		0.013
D (1)	15.8		16	0.622		0.630
D1 (2)	9.4		9.8	0.370		0.386
E	13.9		14.5	0.547		0.570
e		1.27			0.050	
e3		11.43			0.450	
E1 (1)	10.9		11.1	0.429		0.437
E2			2.9			0.114
E3	5.8		6.2	0.228		0.244
G	0		0.1	0.000		0.004
H	15.5		15.9	0.610		0.626
h			1.1			0.043
L	0.8		1.1	0.031		0.043
N	8' (typ.)					
S	8' (max. )					
T		10			0.394	

**OUTLINE AND MECHANICAL DATA**

Weight: 1.9gr

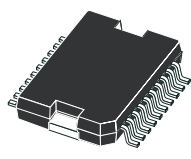

JEDEC MO-166

**PowerSO-20**

(1) "D and E1" do not include mold flash or protusions.  
 - Mold flash or protusions shall not exceed 0.15mm (0.006")  
 - Critical dimensions: "E", "G" and "a3".  
 (2) For subcontractors, the limit is the one quoted in jedec MO-166

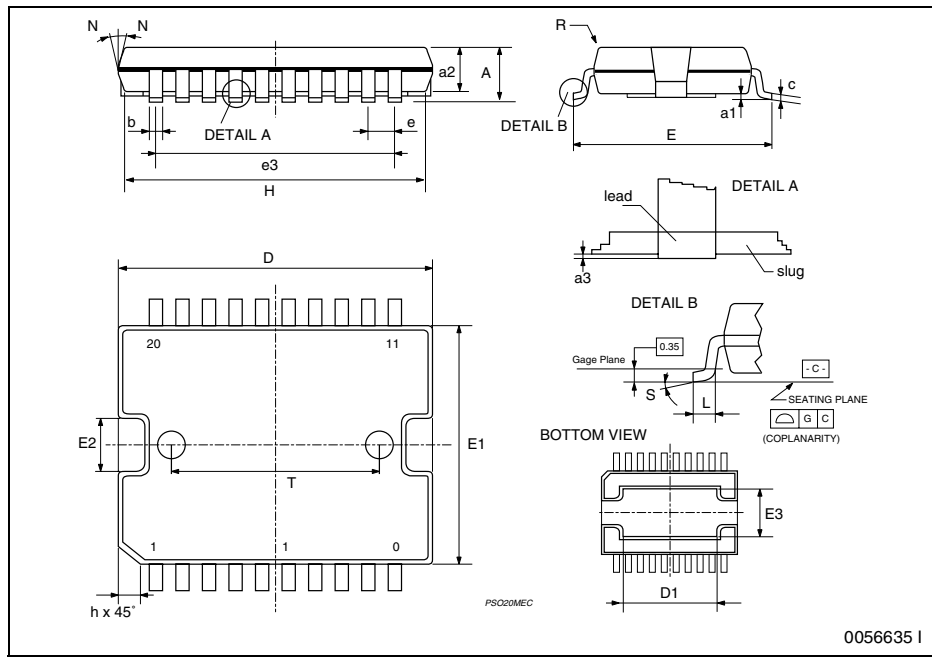

## 4.2 PowerSO-20 packing information

Figure 9. PowerSO-20 tube shipment information

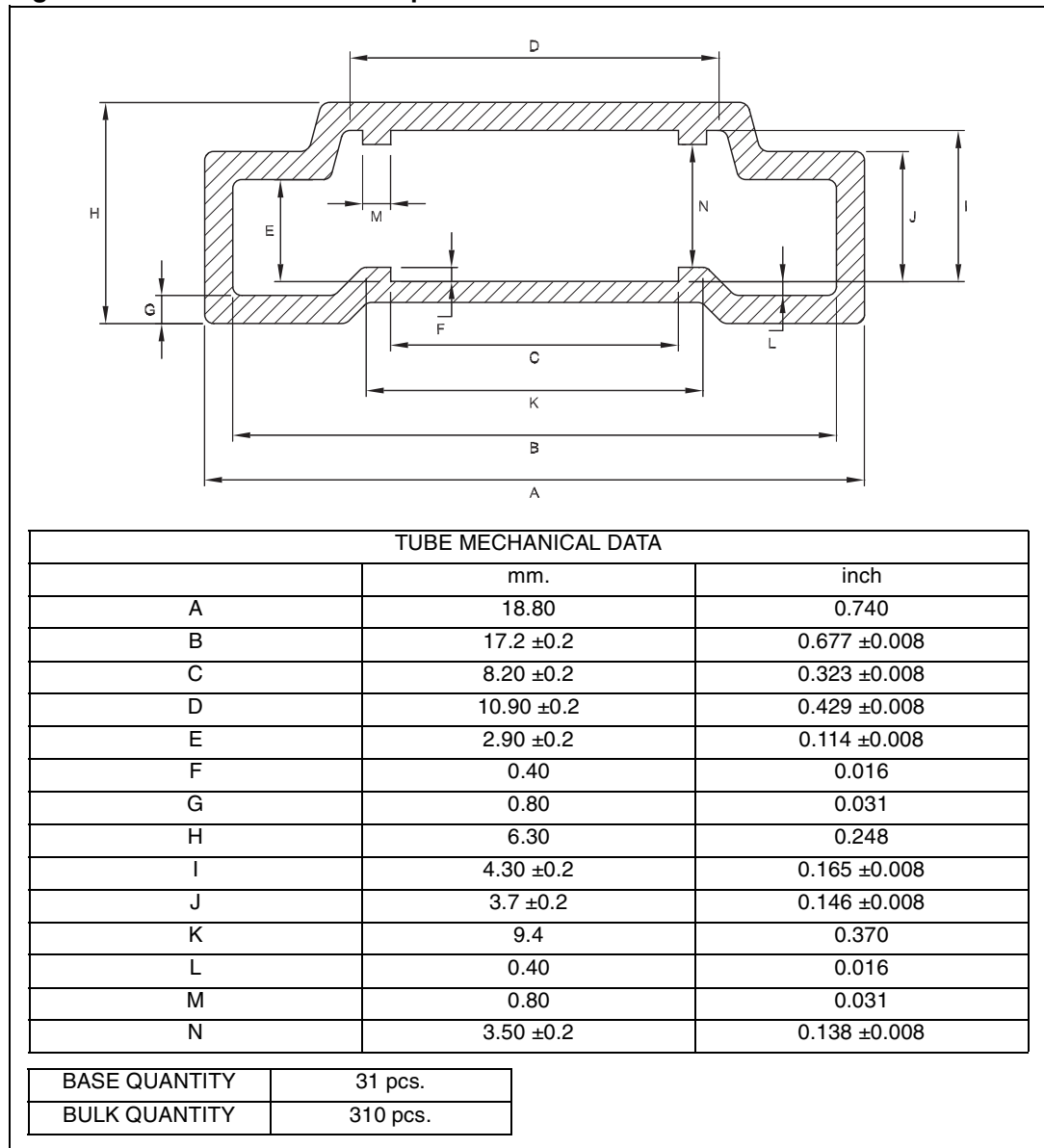

Figure 10. PowerSO-20 tape shipment specification

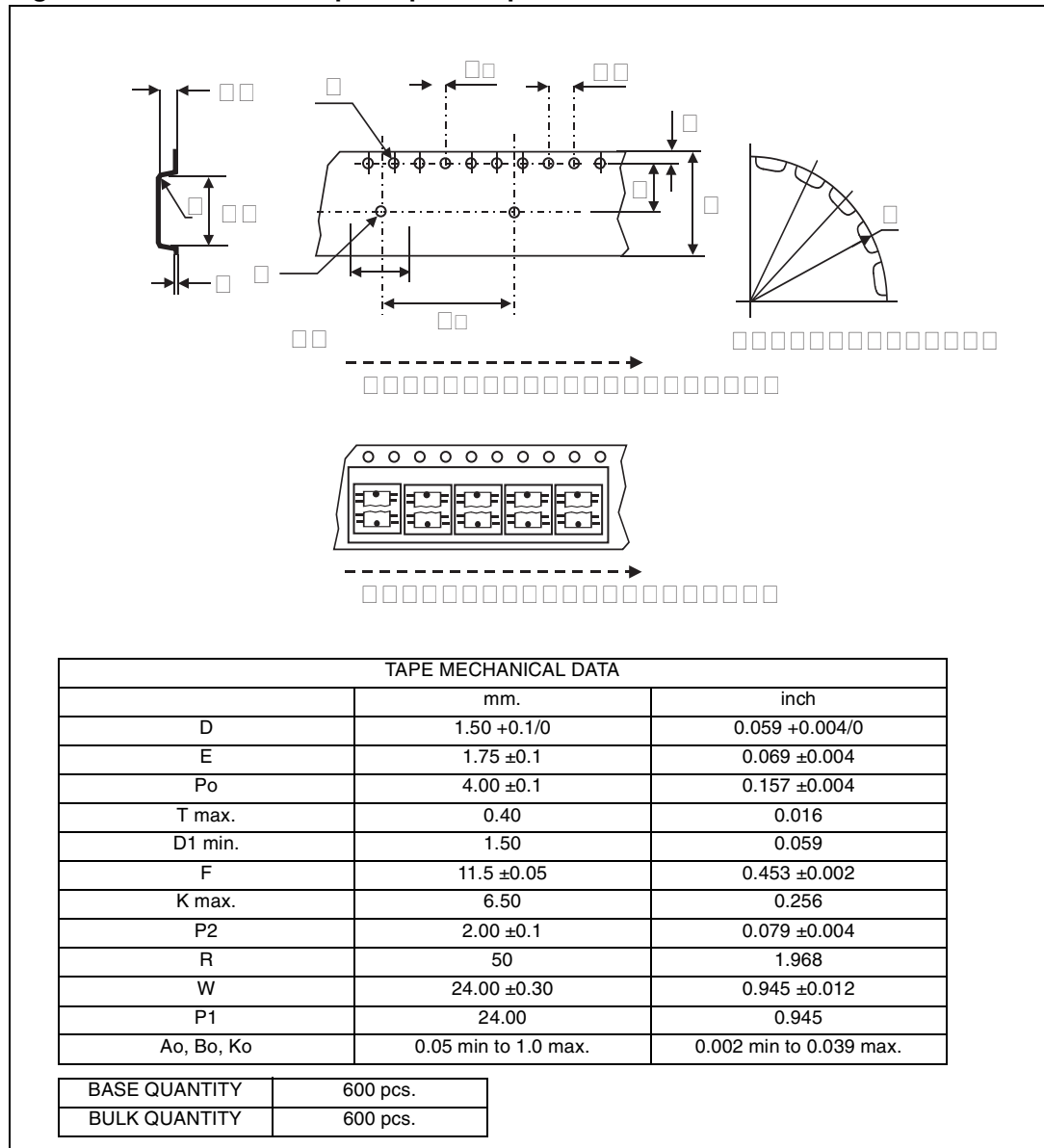

Figure 11. PowerSO-20 reel shipment specification

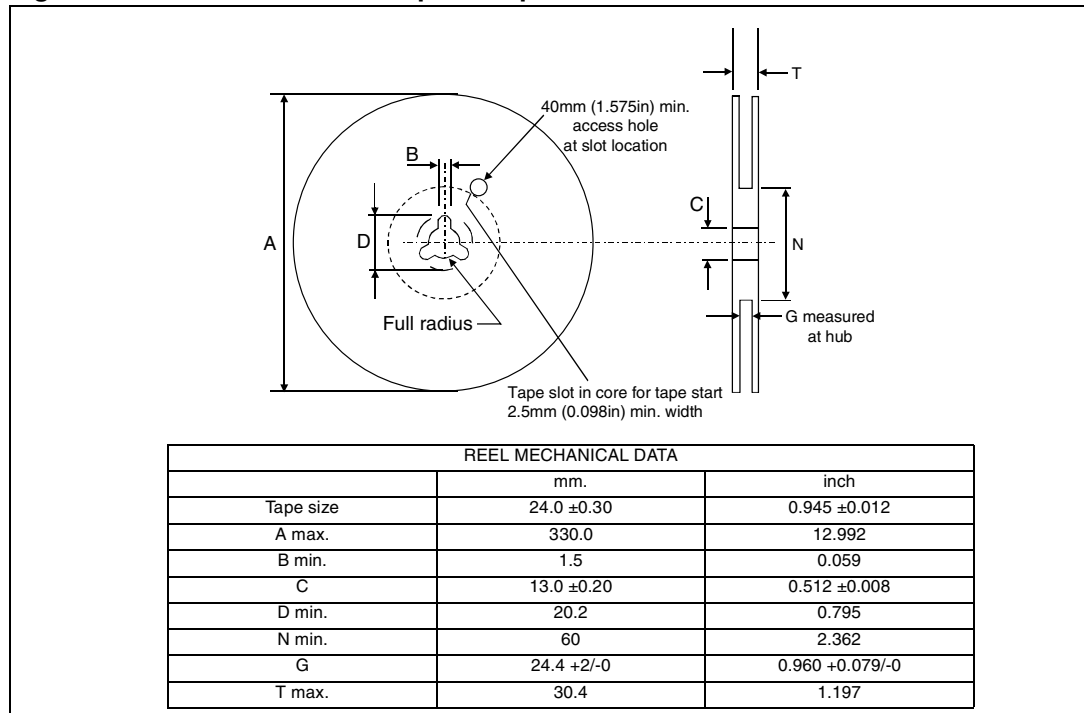
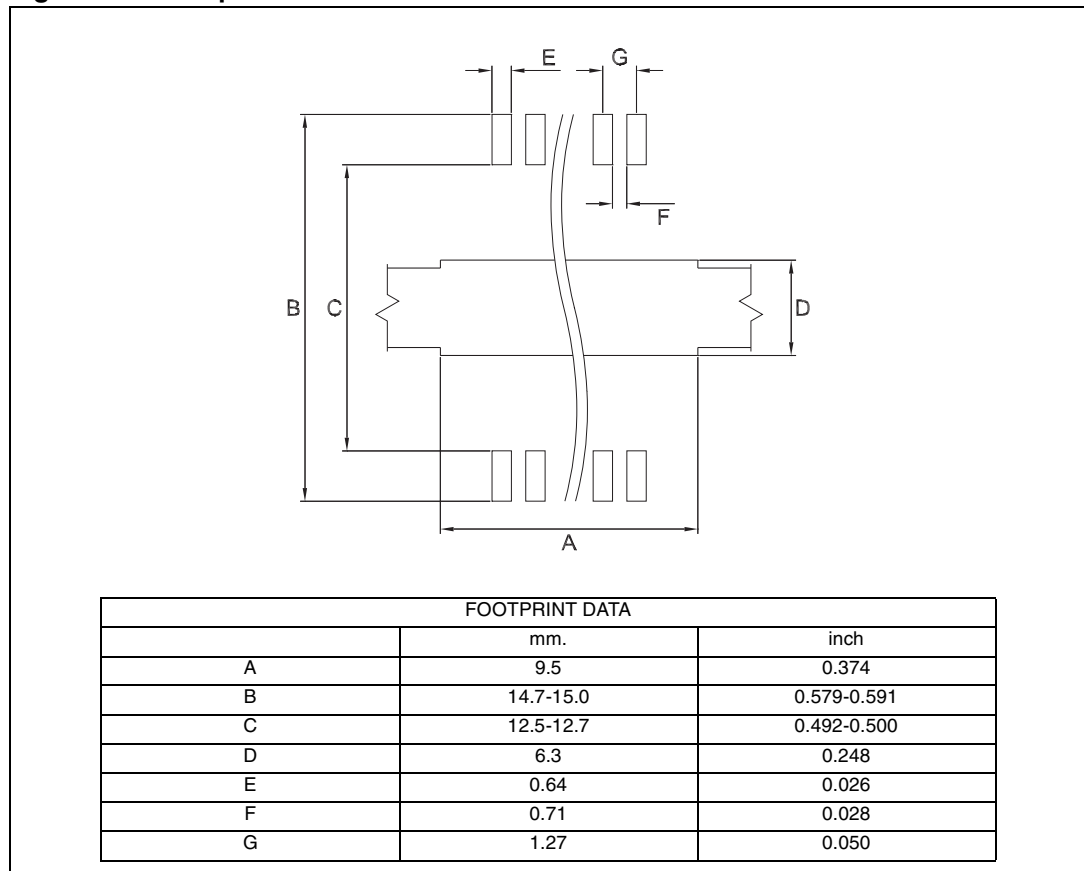

Figure 12. Footprint recommended data



## 5 Revision history

**Table 8. Revision history**

Date	Revision	Changes
10-Aug-2003	3	Initial release.
12-Dec-2005	4	Applied new Look & Feel Style Sheet. Added L6370D013TR part number. Updated Package and Packing section.
26-Apr-2006	5	Document has been reformatted
19-Feb-2007	6	Typo in <a href="#">Figure 2 on page 3</a> .
19-Jun-2007	7	Truth table updated, deleted Multiwatt mechanical information
20-Jul-2010	8	Updated <a href="#">Table 3 on page 5</a> and <a href="#">Table 5 on page 6</a>

**Please Read Carefully:**

Information in this document is provided solely in connection with ST products. STMicroelectronics NV and its subsidiaries ("ST") reserve the right to make changes, corrections, modifications or improvements, to this document, and the products and services described herein at any time, without notice.

All ST products are sold pursuant to ST's terms and conditions of sale.

Purchasers are solely responsible for the choice, selection and use of the ST products and services described herein, and ST assumes no liability whatsoever relating to the choice, selection or use of the ST products and services described herein.

No license, express or implied, by estoppel or otherwise, to any intellectual property rights is granted under this document. If any part of this document refers to any third party products or services it shall not be deemed a license grant by ST for the use of such third party products or services, or any intellectual property contained therein or considered as a warranty covering the use in any manner whatsoever of such third party products or services or any intellectual property contained therein.

**UNLESS OTHERWISE SET FORTH IN ST'S TERMS AND CONDITIONS OF SALE ST DISCLAIMS ANY EXPRESS OR IMPLIED WARRANTY WITH RESPECT TO THE USE AND/OR SALE OF ST PRODUCTS INCLUDING WITHOUT LIMITATION IMPLIED WARRANTIES OF MERCHANTABILITY, FITNESS FOR A PARTICULAR PURPOSE (AND THEIR EQUIVALENTS UNDER THE LAWS OF ANY JURISDICTION), OR INFRINGEMENT OF ANY PATENT, COPYRIGHT OR OTHER INTELLECTUAL PROPERTY RIGHT.**

**UNLESS EXPRESSLY APPROVED IN WRITING BY AN AUTHORIZED ST REPRESENTATIVE, ST PRODUCTS ARE NOT RECOMMENDED, AUTHORIZED OR WARRANTED FOR USE IN MILITARY, AIR CRAFT, SPACE, LIFE SAVING, OR LIFE SUSTAINING APPLICATIONS, NOR IN PRODUCTS OR SYSTEMS WHERE FAILURE OR MALFUNCTION MAY RESULT IN PERSONAL INJURY, DEATH, OR SEVERE PROPERTY OR ENVIRONMENTAL DAMAGE. ST PRODUCTS WHICH ARE NOT SPECIFIED AS "AUTOMOTIVE GRADE" MAY ONLY BE USED IN AUTOMOTIVE APPLICATIONS AT USER'S OWN RISK.**

Resale of ST products with provisions different from the statements and/or technical features set forth in this document shall immediately void any warranty granted by ST for the ST product or service described herein and shall not create or extend in any manner whatsoever, any liability of ST.

ST and the ST logo are trademarks or registered trademarks of ST in various countries.

Information in this document supersedes and replaces all information previously supplied.

The ST logo is a registered trademark of STMicroelectronics. All other names are the property of their respective owners.

© 2010 STMicroelectronics - All rights reserved

STMicroelectronics group of companies

Australia - Belgium - Brazil - Canada - China - Czech Republic - Finland - France - Germany - Hong Kong - India - Israel - Italy - Japan - Malaysia - Malta - Morocco - Philippines - Singapore - Spain - Sweden - Switzerland - United Kingdom - United States of America

[www.st.com](http://www.st.com)

## Looking for pricing, stock, or lifecycle information?

Click below to explore more details on WIN SOURCE:

-  [View L6370D013TR on WIN SOURCE](#)
-  [STMicroelectronics Information](#)

## Optimize Your Supply Chain with WIN SOURCE Solutions

-  Global Sourcing Solution
-  Obsolete Management
-  Cost Control Management
-  Shortage Management
-  Alternative Solution
-  Excess Inventory Management