



THE DATASHEET OF L293NE



L293x Quadruple Half-H Drivers

1 Features

- Wide Supply-Voltage Range: 4.5 V to 36 V
- Separate Input-Logic Supply
- Internal ESD Protection
- High-Noise-Immunity Inputs
- Output Current 1 A Per Channel (600 mA for L293D)
- Peak Output Current 2 A Per Channel (1.2 A for L293D)
- Output Clamp Diodes for Inductive Transient Suppression (L293D)

2 Applications

- Stepper Motor Drivers
- DC Motor Drivers
- Latching Relay Drivers

3 Description

The L293 and L293D devices are quadruple high-current half-H drivers. The L293 is designed to provide bidirectional drive currents of up to 1 A at voltages from 4.5 V to 36 V. The L293D is designed to provide bidirectional drive currents of up to 600-mA at voltages from 4.5 V to 36 V. Both devices are designed to drive inductive loads such as relays, solenoids, DC and bipolar stepping motors, as well as other high-current/high-voltage loads in positive-supply applications.

Each output is a complete totem-pole drive circuit, with a Darlington transistor sink and a pseudo-Darlington source. Drivers are enabled in pairs, with drivers 1 and 2 enabled by 1,2EN and drivers 3 and 4 enabled by 3,4EN.

The L293 and L293D are characterized for operation from 0°C to 70°C.

Device Information⁽¹⁾

PART NUMBER	PACKAGE	BODY SIZE (NOM)
L293NE	PDIP (16)	19.80 mm x 6.35 mm
L293DNE	PDIP (16)	19.80 mm x 6.35 mm

(1) For all available packages, see the orderable addendum at the end of the data sheet.

Logic Diagram

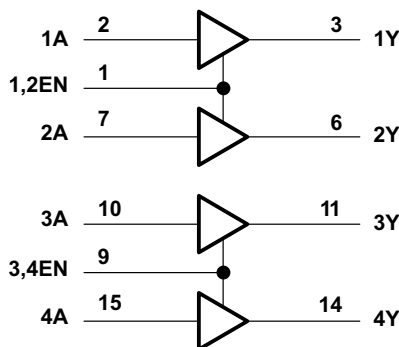

Table of Contents

1 Features	1	8.3 Feature Description	7
2 Applications	1	8.4 Device Functional Modes	8
3 Description	1	9 Application and Implementation	9
4 Revision History	2	9.1 Application Information	9
5 Pin Configuration and Functions	3	9.2 Typical Application	9
6 Specifications	4	9.3 System Examples	10
6.1 Absolute Maximum Ratings	4	10 Power Supply Recommendations	13
6.2 ESD Ratings	4	11 Layout	14
6.3 Recommended Operating Conditions	4	11.1 Layout Guidelines	14
6.4 Thermal Information	4	11.2 Layout Example	14
6.5 Electrical Characteristics	5	12 Device and Documentation Support	15
6.6 Switching Characteristics	5	12.1 Related Links	15
6.7 Typical Characteristics	5	12.2 Community Resources	15
7 Parameter Measurement Information	6	12.3 Trademarks	15
8 Detailed Description	7	12.4 Electrostatic Discharge Caution	15
8.1 Overview	7	12.5 Glossary	15
8.2 Functional Block Diagram	7	13 Mechanical, Packaging, and Orderable Information	15

4 Revision History

NOTE: Page numbers for previous revisions may differ from page numbers in the current version.

Changes from Revision C (November 2004) to Revision D	Page
• Removed <i>Ordering Information</i> table	1
• Added <i>ESD Ratings</i> and <i>Thermal Information</i> tables, <i>Feature Description</i> section, <i>Device Functional Modes</i> , <i>Application and Implementation</i> section, <i>Power Supply Recommendations</i> section, <i>Layout</i> section, <i>Device and Documentation Support</i> section, and <i>Mechanical, Packaging, and Orderable Information</i> section.	1

5 Pin Configuration and Functions

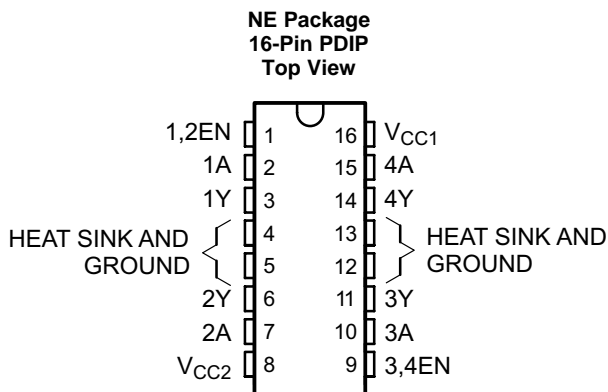

Pin Functions

PIN		TYPE	DESCRIPTION
NAME	NO.		
1,2EN	1	I	Enable driver channels 1 and 2 (active high input)
<1:4>A	2, 7, 10, 15	I	Driver inputs, noninverting
<1:4>Y	3, 6, 11, 14	O	Driver outputs
3,4EN	9	I	Enable driver channels 3 and 4 (active high input)
GROUND	4, 5, 12, 13	—	Device ground and heat sink pin. Connect to printed-circuit-board ground plane with multiple solid vias
V _{CC1}	16	—	5-V supply for internal logic translation
V _{CC2}	8	—	Power VCC for drivers 4.5 V to 36 V

6 Specifications

6.1 Absolute Maximum Ratings

 over operating free-air temperature range (unless otherwise noted)⁽¹⁾

	MIN	MAX	UNIT
Supply voltage, V_{CC1} ⁽²⁾		36	V
Output supply voltage, V_{CC2}		36	V
Input voltage, V_I		7	V
Output voltage, V_O	-3	$V_{CC2} + 3$	V
Peak output current, I_O (nonrepetitive, $t \leq 5$ ms): L293	-2	2	A
Peak output current, I_O (nonrepetitive, $t \leq 100$ μ s): L293D	-1.2	1.2	A
Continuous output current, I_O : L293	-1	1	A
Continuous output current, I_O : L293D	-600	600	mA
Maximum junction temperature, T_J		150	°C
Storage temperature, T_{stg}	-65	150	°C

- (1) Stresses beyond those listed under *Absolute Maximum Ratings* may cause permanent damage to the device. These are stress ratings only, which do not imply functional operation of the device at these or any other conditions beyond those indicated under *Recommended Operating Conditions*. Exposure to absolute-maximum-rated conditions for extended periods may affect device reliability.
- (2) All voltage values are with respect to the network ground terminal.

6.2 ESD Ratings

		VALUE	UNIT
$V_{(ESD)}$	Electrostatic discharge	Human-body model (HBM), per ANSI/ESDA/JEDEC JS-001 ⁽¹⁾	V
		Charged-device model (CDM), per JEDEC specification JESD22-C101 ⁽²⁾	
		± 2000	
		± 1000	

- (1) JEDEC document JEP155 states that 500-V HBM allows safe manufacturing with a standard ESD control process.
- (2) JEDEC document JEP157 states that 250-V CDM allows safe manufacturing with a standard ESD control process.

6.3 Recommended Operating Conditions

over operating free-air temperature range (unless otherwise noted)

		MIN	NOM	MAX	UNIT
Supply voltage	V_{CC1}	4.5		7	V
	V_{CC2}	V_{CC1}		36	
V_{IH}	High-level input voltage	$V_{CC1} \leq 7$ V		V_{CC1}	V
		$V_{CC1} \geq 7$ V	2.3	7	V
V_{IL}	Low-level output voltage	-0.3 ⁽¹⁾		1.5	V
T_A	Operating free-air temperature	0		70	°C

- (1) The algebraic convention, in which the least positive (most negative) designated minimum, is used in this data sheet for logic voltage levels.

6.4 Thermal Information

THERMAL METRIC ⁽¹⁾		L293, L293D	UNIT
		NE (PDIP)	
		16 PINS	
$R_{\theta JA}$	Junction-to-ambient thermal resistance ⁽²⁾	36.4	°C/W
$R_{\theta JC(top)}$	Junction-to-case (top) thermal resistance	22.5	°C/W
$R_{\theta JB}$	Junction-to-board thermal resistance	16.5	°C/W
Ψ_{JT}	Junction-to-top characterization parameter	7.1	°C/W
Ψ_{JB}	Junction-to-board characterization parameter	16.3	°C/W

- (1) For more information about traditional and new thermal metrics, see the *Semiconductor and IC Package Thermal Metrics* application report, [SPRA953](#).
- (2) The package thermal impedance is calculated in accordance with JESD 51-7.

6.5 Electrical Characteristics

over operating free-air temperature range (unless otherwise noted)

PARAMETER		TEST CONDITIONS		MIN	TYP	MAX	UNIT
V _{OH}	High-level output voltage	L293: I _{OH} = -1 A		V _{CC2} - 1.8	V _{CC2} - 1.4		V
		L293D: I _{OH} = -0.6 A					
V _{OL}	Low-level output voltage	L293: I _{OL} = 1 A			1.2	1.8	V
		L293D: I _{OL} = 0.6 A					
V _{OKH}	High-level output clamp voltage	L293D: I _{OK} = -0.6 A		V _{CC2} + 1.3			V
V _{OKL}	Low-level output clamp voltage	L293D: I _{OK} = 0.6 A		1.3			V
I _{IH}	High-level input current	A	V _I = 7 V	0.2		100	μA
		EN		0.2		10	
I _{IL}	Low-level input current	A	V _I = 0	-3		-10	μA
		EN		-2		-100	
I _{CC1}	Logic supply current	I _O = 0	All outputs at high level	13		22	mA
			All outputs at low level	35		60	
			All outputs at high impedance	8		24	
I _{CC2}	Output supply current	I _O = 0	All outputs at high level	14		24	mA
			All outputs at low level	2		6	
			All outputs at high impedance	2		4	

6.6 Switching Characteristics

over operating free-air temperature range (unless otherwise noted) V_{CC1} = 5 V, V_{CC2} = 24 V, T_A = 25°C

PARAMETER		TEST CONDITIONS		MIN	TYP	MAX	UNIT
t _{PLH}	Propagation delay time, low-to-high-level output from A input	L293NE, L293DNE		800			ns
		L293DWP, L293N L293DN		750			
t _{PHL}	Propagation delay time, high-to-low-level output from A input	L293NE, L293DNE		400			ns
		L293DWP, L293N L293DN		200			
t _{TLH}	Transition time, low-to-high-level output	L293NE, L293DNE		300			ns
		L293DWP, L293N L293DN		100			
t _{THL}	Transition time, high-to-low-level output	L293NE, L293DNE		300			ns
		L293DWP, L293N L293DN		350			

C_L = 30 pF, See Figure 2

6.7 Typical Characteristics

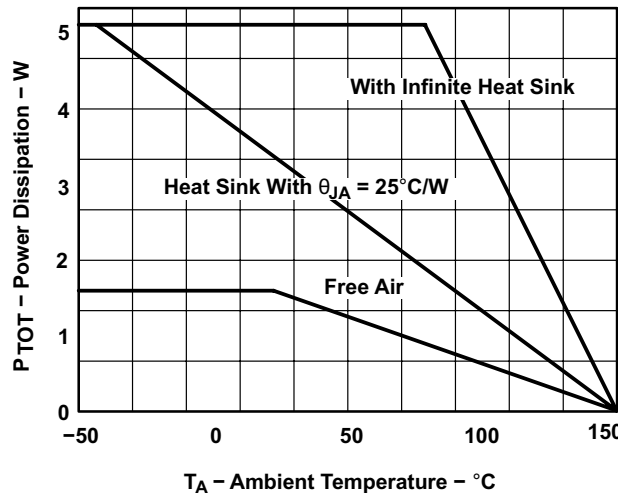
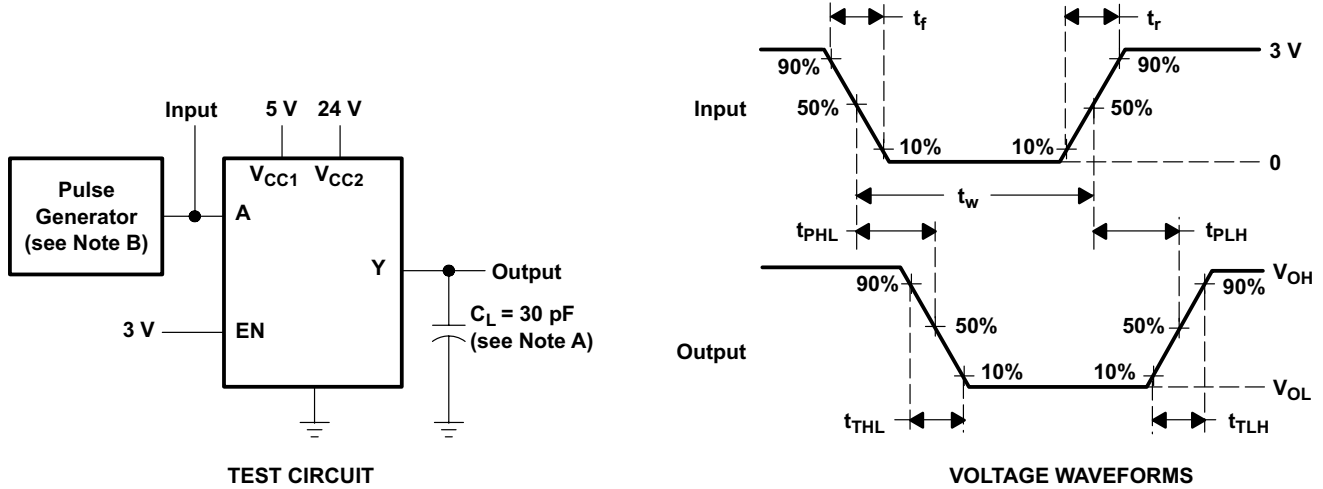

Figure 1. Maximum Power Dissipation vs Ambient Temperature

7 Parameter Measurement Information



NOTES: A. C_L includes probe and jig capacitance.

B. The pulse generator has the following characteristics: $t_r \leq 10$ ns, $t_f \leq 10$ ns, $t_w = 10$ μ s, PRR = 5 kHz, $Z_O = 50$ Ω .

Figure 2. Test Circuit and Voltage Waveforms

8 Detailed Description

8.1 Overview

The L293 and L293D are quadruple high-current half-H drivers. These devices are designed to drive a wide array of inductive loads such as relays, solenoids, DC and bipolar stepping motors, as well as other high-current and high-voltage loads. All inputs are TTL compatible and tolerant up to 7 V.

Each output is a complete totem-pole drive circuit, with a Darlington transistor sink and a pseudo-Darlington source. Drivers are enabled in pairs, with drivers 1 and 2 enabled by 1,2EN and drivers 3 and 4 enabled by 3,4EN. When an enable input is high, the associated drivers are enabled, and their outputs are active and in phase with their inputs. When the enable input is low, those drivers are disabled, and their outputs are off and in the high-impedance state. With the proper data inputs, each pair of drivers forms a full-H (or bridge) reversible drive suitable for solenoid or motor applications.

On the L293, external high-speed output clamp diodes should be used for inductive transient suppression. On the L293D, these diodes are integrated to reduce system complexity and overall system size. A V_{CC1} terminal, separate from V_{CC2} , is provided for the logic inputs to minimize device power dissipation. The L293 and L293D are characterized for operation from 0°C to 70°C.

8.2 Functional Block Diagram

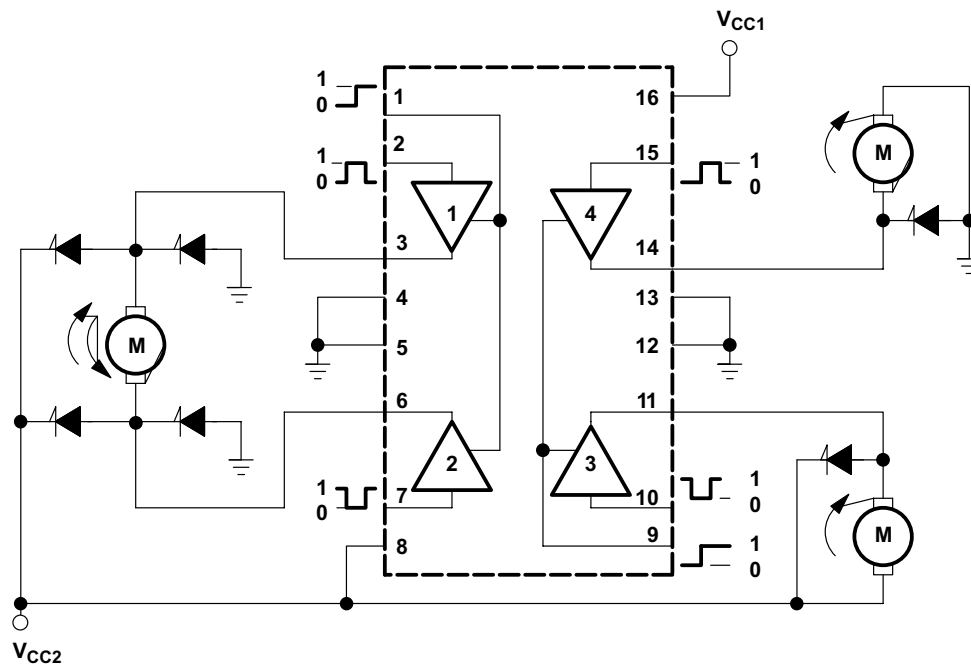

Output diodes are internal in L293D.

8.3 Feature Description

The L293x has TTL-compatible inputs and high voltage outputs for inductive load driving. Current outputs can get up to 2 A using the L293.

8.4 Device Functional Modes

Table 1 lists the functional modes of the L293x.

Table 1. Function Table (Each Driver)⁽¹⁾

INPUTS ⁽²⁾		OUTPUT (Y)
A	EN	
H	H	H
L	H	L
X	L	Z

(1) H = high level, L = low level, X = irrelevant, Z = high impedance (off)

(2) In the thermal shutdown mode, the output is in the high-impedance state, regardless of the input levels.

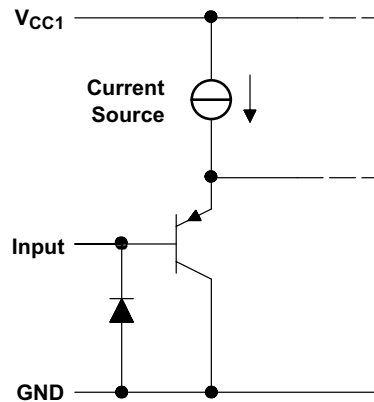

Figure 3. Schematic of Inputs for the L293x

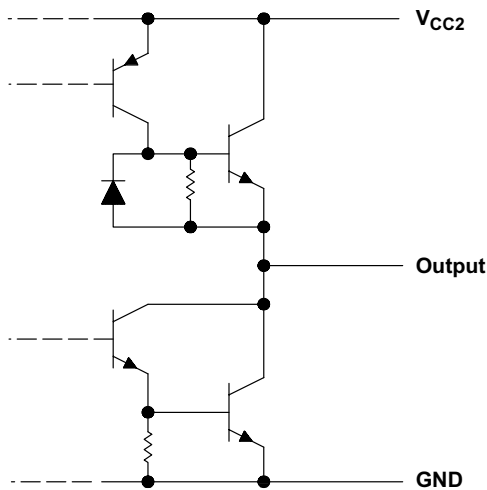

Figure 4. Schematic of Outputs for the L293

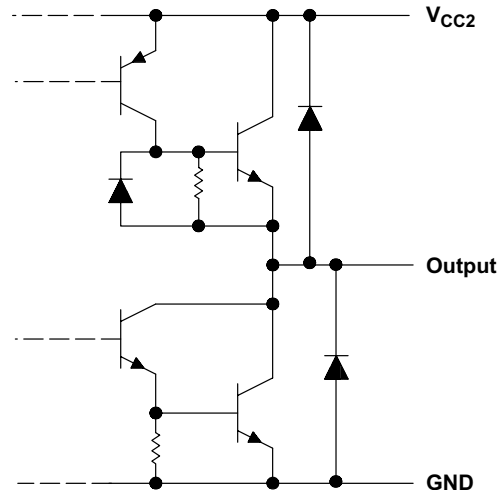

Figure 5. Schematic of Outputs for the L293D

9 Application and Implementation

NOTE

Information in the following applications sections is not part of the TI component specification, and TI does not warrant its accuracy or completeness. TI's customers are responsible for determining suitability of components for their purposes. Customers should validate and test their design implementation to confirm system functionality.

9.1 Application Information

A typical application for the L293 device is driving a two-phase motor. Below is an example schematic displaying how to properly connect a two-phase motor to the L293 device.

Provide a 5-V supply to V_{CC1} and valid logic input levels to data and enable inputs. V_{CC2} must be connected to a power supply capable of supplying the needed current and voltage demand for the loads connected to the outputs.

9.2 Typical Application

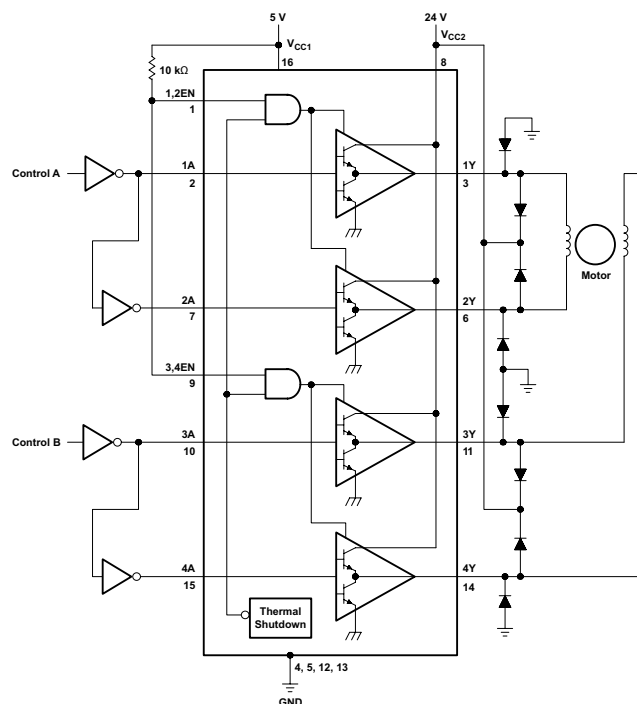

Figure 6. Two-Phase Motor Driver (L293)

9.2.1 Design Requirements

The design techniques in the application above as well as the applications below should fall within the following design requirements.

1. V_{CC1} should fall within the limits described in the [Recommended Operating Conditions](#).
2. V_{CC2} should fall within the limits described in the [Recommended Operating Conditions](#).
3. The current per channel should not exceed 1 A for the L293 (600mA for the L293D).

9.2.2 Detailed Design Procedure

When designing with the L293 or L293D, careful consideration should be made to ensure the device does not exceed the operating temperature of the device. Proper heatsinking will allow for operation over a larger range of current per channel. Refer to the [Power Supply Recommendations](#) as well as the [Layout Example](#).

System Examples (continued)

9.3.2 DC Motor Controls

Figure 9 and Figure 10 below depict a typical setup for using the L293 device as a controller for DC motors. Note that the L293 device can be used as a simple driver for a motor to turn on and off in one direction, and can also be used to drive a motor in both directions. Refer to the function tables below to understand unidirectional vs bidirectional motor control. Refer to the *Recommended Operating Conditions* when considering the appropriate input high and input low voltage levels to enable each channel of the device.

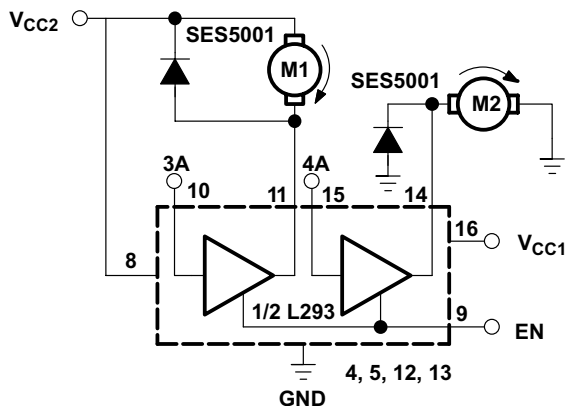

Connections to ground and to supply voltage

Figure 9. DC Motor Controls

Table 2. Unidirectional DC Motor Control

EN	3A	M1 ⁽¹⁾	4A	M2
H	H	Fast motor stop	H	Run
H	L	run	L	Fast motor stop
L	X	Free-running motor stop	X	Free-running motor stop

(1) L = low, H = high, X = don't care

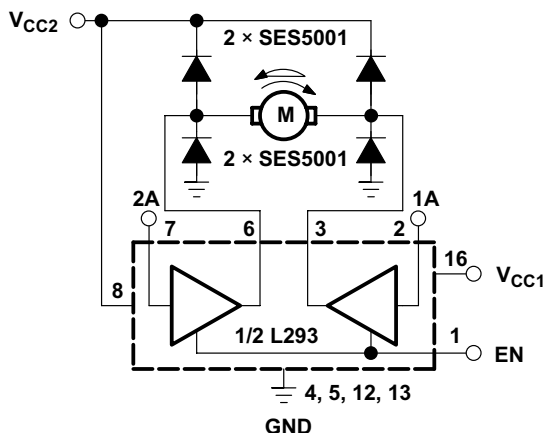

Figure 10. Bidirectional DC Motor Control

Table 3. Bidirectional DC Motor Control

EN	1A	2A	FUNCTION ⁽¹⁾
H	L	H	Turn right
H	H	L	Turn left

(1) L = low, H = high, X = don't care

Table 3. Bidirectional DC Motor Control (continued)

EN	1A	2A	FUNCTION ⁽¹⁾
H	L	L	Fast motor stop
H	H	H	Fast motor stop
L	X	X	Free-running motor stop

9.3.3 Bipolar Stepping-Motor Control

Figure 11 below depicts a typical setup for using the L293D as a two-phase motor driver. Refer to the [Recommended Operating Conditions](#) when considering the appropriate input high and input low voltage levels to enable each channel of the device.

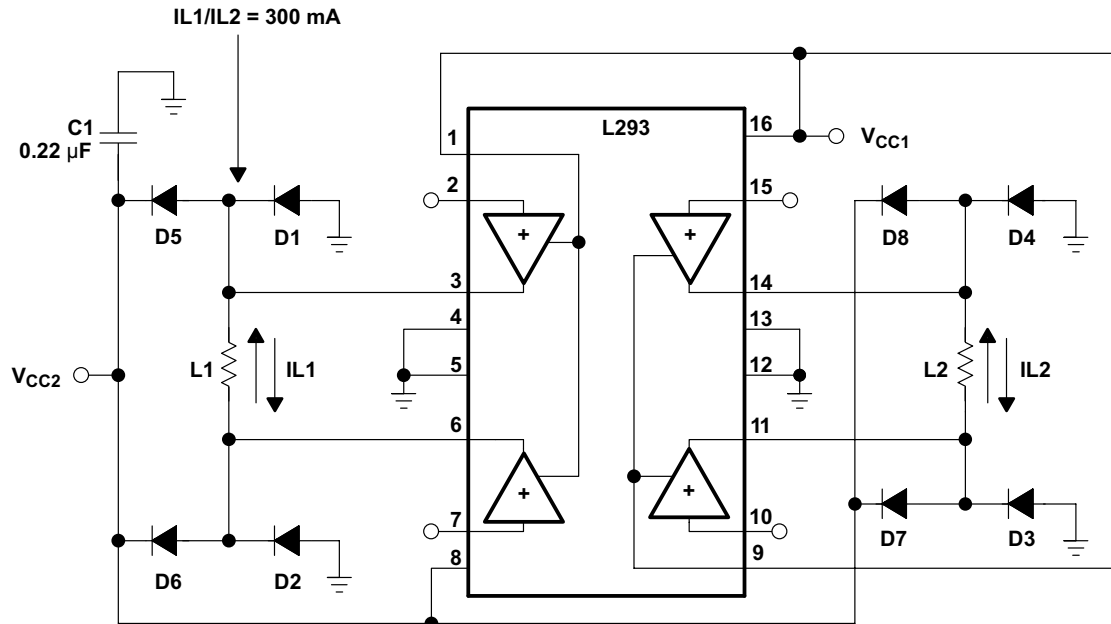

D1–D8 = SES5001

Figure 11. Bipolar Stepping-Motor Control

10 Power Supply Recommendations

V_{CC1} is $5\text{ V} \pm 0.5\text{ V}$ and V_{CC2} can be same supply as V_{CC1} or a higher voltage supply with peak voltage up to 36 V. Bypass capacitors of 0.1 μF or greater should be used at V_{CC1} and V_{CC2} pins. There are no power up or power down supply sequence order requirements.

Properly heatsinking the L293 when driving high-current is critical to design. The $R_{thj-amp}$ of the L293 can be reduced by soldering the GND pins to a suitable copper area of the printed circuit board or to an external heat sink.

Figure 14 shows the maximum package power $PTOT$ and the θ_{JA} as a function of the side of two equal square copper areas having a thickness of 35 μm (see Figure 14). In addition, an external heat sink can be used (see Figure 12).

During soldering, the pin temperature must not exceed 260°C, and the soldering time must not exceed 12 seconds.

The external heatsink or printed circuit copper area must be connected to electrical ground.

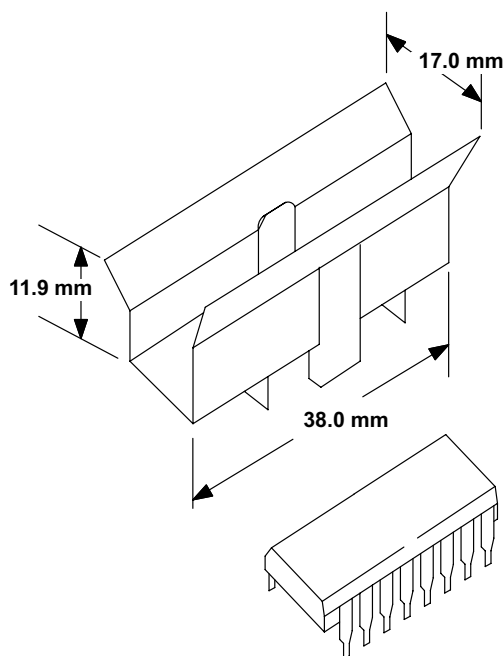

Figure 12. External Heat Sink Mounting Example ($\theta_{JA} = 25^\circ\text{C/W}$)

11 Layout

11.1 Layout Guidelines

Place the device near the load to keep output traces short to reduce EMI. Use solid vias to transfer heat from ground pins to ground plane of the printed-circuit-board.

11.2 Layout Example

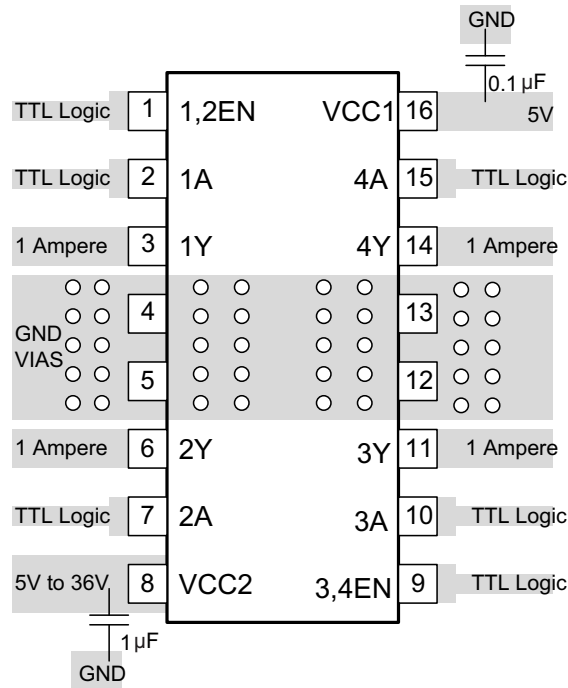

Figure 13. Layout Diagram

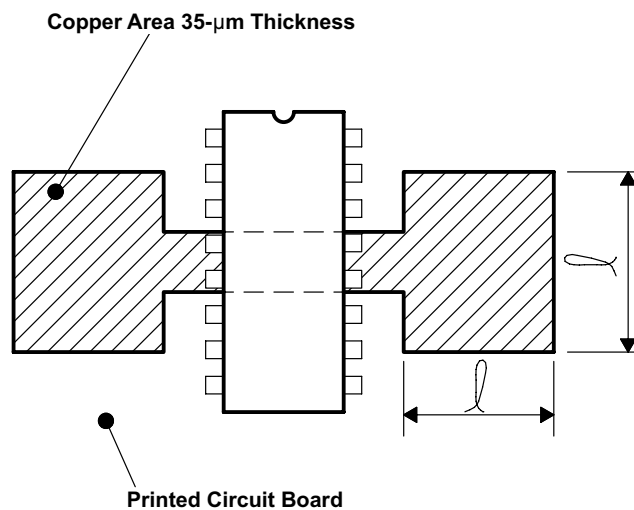

Figure 14. Example of Printed-Circuit-Board Copper Area (Used as Heat Sink)

12 Device and Documentation Support

12.1 Related Links

The table below lists quick access links. Categories include technical documents, support and community resources, tools and software, and quick access to sample or buy.

Table 4. Related Links

PARTS	PRODUCT FOLDER	SAMPLE & BUY	TECHNICAL DOCUMENTS	TOOLS & SOFTWARE	SUPPORT & COMMUNITY
L293	Click here	Click here	Click here	Click here	Click here
L293D	Click here	Click here	Click here	Click here	Click here

12.2 Community Resources

The following links connect to TI community resources. Linked contents are provided "AS IS" by the respective contributors. They do not constitute TI specifications and do not necessarily reflect TI's views; see TI's [Terms of Use](#).

TI E2E™ Online Community *TI's Engineer-to-Engineer (E2E) Community*. Created to foster collaboration among engineers. At e2e.ti.com, you can ask questions, share knowledge, explore ideas and help solve problems with fellow engineers.

Design Support *TI's Design Support* Quickly find helpful E2E forums along with design support tools and contact information for technical support.

12.3 Trademarks

E2E is a trademark of Texas Instruments.
All other trademarks are the property of their respective owners.

12.4 Electrostatic Discharge Caution



These devices have limited built-in ESD protection. The leads should be shorted together or the device placed in conductive foam during storage or handling to prevent electrostatic damage to the MOS gates.

12.5 Glossary

SLYZ022 — *TI Glossary*.

This glossary lists and explains terms, acronyms, and definitions.

13 Mechanical, Packaging, and Orderable Information

The following pages include mechanical, packaging, and orderable information. This information is the most current data available for the designated devices. This data is subject to change without notice and revision of this document. For browser-based versions of this data sheet, refer to the left-hand navigation.

PACKAGING INFORMATION

Orderable Device	Status (1)	Package Type	Package Drawing	Pins	Package Qty	Eco Plan (2)	Lead/Ball Finish (6)	MSL Peak Temp (3)	Op Temp (°C)	Device Marking (4/5)	Samples
L293DNE	ACTIVE	PDIP	NE	16	25	Pb-Free (RoHS)	CU NIPDAU	N / A for Pkg Type	0 to 70	L293DNE	Samples
L293DNEE4	ACTIVE	PDIP	NE	16	25	Pb-Free (RoHS)	CU NIPDAU	N / A for Pkg Type	0 to 70	L293DNE	Samples
L293NE	ACTIVE	PDIP	NE	16	25	Pb-Free (RoHS)	CU NIPDAU	N / A for Pkg Type	0 to 70	L293NE	Samples
L293NEE4	ACTIVE	PDIP	NE	16	25	Pb-Free (RoHS)	CU NIPDAU	N / A for Pkg Type	0 to 70	L293NE	Samples

(1) The marketing status values are defined as follows:

ACTIVE: Product device recommended for new designs.

LIFEBUY: TI has announced that the device will be discontinued, and a lifetime-buy period is in effect.

NRND: Not recommended for new designs. Device is in production to support existing customers, but TI does not recommend using this part in a new design.

PREVIEW: Device has been announced but is not in production. Samples may or may not be available.

OBsolete: TI has discontinued the production of the device.

(2) Eco Plan - The planned eco-friendly classification: Pb-Free (RoHS), Pb-Free (RoHS Exempt), or Green (RoHS & no Sb/Br) - please check <http://www.ti.com/productcontent> for the latest availability information and additional product content details.

TBD: The Pb-Free/Green conversion plan has not been defined.

Pb-Free (RoHS): TI's terms "Lead-Free" or "Pb-Free" mean semiconductor products that are compatible with the current RoHS requirements for all 6 substances, including the requirement that lead not exceed 0.1% by weight in homogeneous materials. Where designed to be soldered at high temperatures, TI Pb-Free products are suitable for use in specified lead-free processes.

Pb-Free (RoHS Exempt): This component has a RoHS exemption for either 1) lead-based flip-chip solder bumps used between the die and package, or 2) lead-based die adhesive used between the die and leadframe. The component is otherwise considered Pb-Free (RoHS compatible) as defined above.

Green (RoHS & no Sb/Br): TI defines "Green" to mean Pb-Free (RoHS compatible), and free of Bromine (Br) and Antimony (Sb) based flame retardants (Br or Sb do not exceed 0.1% by weight in homogeneous material)

(3) MSL, Peak Temp. - The Moisture Sensitivity Level rating according to the JEDEC industry standard classifications, and peak solder temperature.

(4) There may be additional marking, which relates to the logo, the lot trace code information, or the environmental category on the device.

(5) Multiple Device Markings will be inside parentheses. Only one Device Marking contained in parentheses and separated by a "~" will appear on a device. If a line is indented then it is a continuation of the previous line and the two combined represent the entire Device Marking for that device.

(6) Lead/Ball Finish - Orderable Devices may have multiple material finish options. Finish options are separated by a vertical ruled line. Lead/Ball Finish values may wrap to two lines if the finish value exceeds the maximum column width.

Important Information and Disclaimer: The information provided on this page represents TI's knowledge and belief as of the date that it is provided. TI bases its knowledge and belief on information provided by third parties, and makes no representation or warranty as to the accuracy of such information. Efforts are underway to better integrate information from third parties. TI has taken and continues to take reasonable steps to provide representative and accurate information but may not have conducted destructive testing or chemical analysis on incoming materials and chemicals. TI and TI suppliers consider certain information to be proprietary, and thus CAS numbers and other limited information may not be available for release.

In no event shall TI's liability arising out of such information exceed the total purchase price of the TI part(s) at issue in this document sold by TI to Customer on an annual basis.

IMPORTANT NOTICE

Texas Instruments Incorporated (TI) reserves the right to make corrections, enhancements, improvements and other changes to its semiconductor products and services per JESD46, latest issue, and to discontinue any product or service per JESD48, latest issue. Buyers should obtain the latest relevant information before placing orders and should verify that such information is current and complete.

TI's published terms of sale for semiconductor products (<http://www.ti.com/sc/docs/stdterms.htm>) apply to the sale of packaged integrated circuit products that TI has qualified and released to market. Additional terms may apply to the use or sale of other types of TI products and services.

Reproduction of significant portions of TI information in TI data sheets is permissible only if reproduction is without alteration and is accompanied by all associated warranties, conditions, limitations, and notices. TI is not responsible or liable for such reproduced documentation. Information of third parties may be subject to additional restrictions. Resale of TI products or services with statements different from or beyond the parameters stated by TI for that product or service voids all express and any implied warranties for the associated TI product or service and is an unfair and deceptive business practice. TI is not responsible or liable for any such statements.

Buyers and others who are developing systems that incorporate TI products (collectively, "Designers") understand and agree that Designers remain responsible for using their independent analysis, evaluation and judgment in designing their applications and that Designers have full and exclusive responsibility to assure the safety of Designers' applications and compliance of their applications (and of all TI products used in or for Designers' applications) with all applicable regulations, laws and other applicable requirements. Designer represents that, with respect to their applications, Designer has all the necessary expertise to create and implement safeguards that (1) anticipate dangerous consequences of failures, (2) monitor failures and their consequences, and (3) lessen the likelihood of failures that might cause harm and take appropriate actions. Designer agrees that prior to using or distributing any applications that include TI products, Designer will thoroughly test such applications and the functionality of such TI products as used in such applications.

TI's provision of technical, application or other design advice, quality characterization, reliability data or other services or information, including, but not limited to, reference designs and materials relating to evaluation modules, (collectively, "TI Resources") are intended to assist designers who are developing applications that incorporate TI products; by downloading, accessing or using TI Resources in any way, Designer (individually or, if Designer is acting on behalf of a company, Designer's company) agrees to use any particular TI Resource solely for this purpose and subject to the terms of this Notice.

TI's provision of TI Resources does not expand or otherwise alter TI's applicable published warranties or warranty disclaimers for TI products, and no additional obligations or liabilities arise from TI providing such TI Resources. TI reserves the right to make corrections, enhancements, improvements and other changes to its TI Resources. TI has not conducted any testing other than that specifically described in the published documentation for a particular TI Resource.

Designer is authorized to use, copy and modify any individual TI Resource only in connection with the development of applications that include the TI product(s) identified in such TI Resource. NO OTHER LICENSE, EXPRESS OR IMPLIED, BY ESTOPPEL OR OTHERWISE TO ANY OTHER TI INTELLECTUAL PROPERTY RIGHT, AND NO LICENSE TO ANY TECHNOLOGY OR INTELLECTUAL PROPERTY RIGHT OF TI OR ANY THIRD PARTY IS GRANTED HEREIN, including but not limited to any patent right, copyright, mask work right, or other intellectual property right relating to any combination, machine, or process in which TI products or services are used. Information regarding or referencing third-party products or services does not constitute a license to use such products or services, or a warranty or endorsement thereof. Use of TI Resources may require a license from a third party under the patents or other intellectual property of the third party, or a license from TI under the patents or other intellectual property of TI.

TI RESOURCES ARE PROVIDED "AS IS" AND WITH ALL FAULTS. TI DISCLAIMS ALL OTHER WARRANTIES OR REPRESENTATIONS, EXPRESS OR IMPLIED, REGARDING RESOURCES OR USE THEREOF, INCLUDING BUT NOT LIMITED TO ACCURACY OR COMPLETENESS, TITLE, ANY EPIDEMIC FAILURE WARRANTY AND ANY IMPLIED WARRANTIES OF MERCHANTABILITY, FITNESS FOR A PARTICULAR PURPOSE, AND NON-INFRINGEMENT OF ANY THIRD PARTY INTELLECTUAL PROPERTY RIGHTS. TI SHALL NOT BE LIABLE FOR AND SHALL NOT DEFEND OR INDEMNIFY DESIGNER AGAINST ANY CLAIM, INCLUDING BUT NOT LIMITED TO ANY INFRINGEMENT CLAIM THAT RELATES TO OR IS BASED ON ANY COMBINATION OF PRODUCTS EVEN IF DESCRIBED IN TI RESOURCES OR OTHERWISE. IN NO EVENT SHALL TI BE LIABLE FOR ANY ACTUAL, DIRECT, SPECIAL, COLLATERAL, INDIRECT, PUNITIVE, INCIDENTAL, CONSEQUENTIAL OR EXEMPLARY DAMAGES IN CONNECTION WITH OR ARISING OUT OF TI RESOURCES OR USE THEREOF, AND REGARDLESS OF WHETHER TI HAS BEEN ADVISED OF THE POSSIBILITY OF SUCH DAMAGES.

Unless TI has explicitly designated an individual product as meeting the requirements of a particular industry standard (e.g., ISO/TS 16949 and ISO 26262), TI is not responsible for any failure to meet such industry standard requirements.

Where TI specifically promotes products as facilitating functional safety or as compliant with industry functional safety standards, such products are intended to help enable customers to design and create their own applications that meet applicable functional safety standards and requirements. Using products in an application does not by itself establish any safety features in the application. Designers must ensure compliance with safety-related requirements and standards applicable to their applications. Designer may not use any TI products in life-critical medical equipment unless authorized officers of the parties have executed a special contract specifically governing such use. Life-critical medical equipment is medical equipment where failure of such equipment would cause serious bodily injury or death (e.g., life support, pacemakers, defibrillators, heart pumps, neurostimulators, and implantables). Such equipment includes, without limitation, all medical devices identified by the U.S. Food and Drug Administration as Class III devices and equivalent classifications outside the U.S.

TI may expressly designate certain products as completing a particular qualification (e.g., Q100, Military Grade, or Enhanced Product). Designers agree that it has the necessary expertise to select the product with the appropriate qualification designation for their applications and that proper product selection is at Designers' own risk. Designers are solely responsible for compliance with all legal and regulatory requirements in connection with such selection.

Designer will fully indemnify TI and its representatives against any damages, costs, losses, and/or liabilities arising out of Designer's non-compliance with the terms and provisions of this Notice.

Looking for pricing, stock, or lifecycle information?

Click below to explore more details on WIN SOURCE:

 [View L293NE](#) on WIN SOURCE

 [Texas Instruments](#) Information

Optimize Your Supply Chain with WIN SOURCE Solutions

-  Global Sourcing Solution
-  Obsolete Management
-  Cost Control Management
-  Shortage Management
-  Alternative Solution
-  Excess Inventory Management