

Hall Effect Current Sensors L18P***D15 Series



Features:

- Open Loop type
- Printed circuit board mounting
- Integrated primary
- Voltage output
- Busbar version from 40A to 60A
- Insulated plastic case according to UL94V0
- UL Recognition

Advantage:

- Excellent accuracy and linearity
- Wide nominal current range
- Low temperature drift
- Wide frequency bandwidth
- No insertion loss
- High Immunity To External Interference
- Optimised response time
- Current overload capability

Specifications

 $T_A=25^{\circ}\text{C}$, $V_{CC}=\pm 15\text{V}$, $R_L=10\text{k}\Omega$

Parameters	Symbol	L18P003 D15	L18P005 D15	L18P010 D15	L18P015 D15	L18P020 D15	L18P025 D15	L18P030 D15	L18P040 D15	L18P050 D15	L18P060 D15
Primary nominal current	I_f	3A	5A	10A	15A	20A	25A	30A	40A	50A	60A
Saturation current	I_{fmax}	$\geq \pm I_f \times 3$									
Rated output voltage	V_o	$4\text{V} \pm 0.040\text{V}$ (at I_f)							$4\text{V} \pm 0.050\text{V}$ (at I_f)		
Offset voltage ¹	V_{of}	$\leq \pm 0.040\text{V}$ (at $I_f=0\text{A}$)							$\leq \pm 0.050\text{V}$ (at $I_f=0\text{A}$)		
Output linearity ² (0A~ I_f)	ϵ_L	$\leq \pm 1\%$ (at I_f)									
Power supply voltage	V_{CC}	$\pm 15\text{V} \pm 5\%$									
Consumption current	I_{CC}	$\leq \pm 15\text{mA}$									
Response time ³	t_r	$\leq 5\mu\text{s}$ (at $di/dt = I_f / \mu\text{s}$)									
Thermal drift of gain ⁴	$TcVo$	$\leq \pm 0.1\%/^{\circ}\text{C}$									
Thermal drift of offset	$TcVof$	$\leq \pm 1.5\text{mV}/^{\circ}\text{C}$									
Hysteresis error (at $I_f=0\text{A} \rightarrow I_f \rightarrow 0\text{A}$)	V_{OH}	$\leq 25\text{mV}$							$\leq 40\text{mV}$		
Insulation voltage	V_d	AC3000V for 1minute (sensing current 0.5mA), primary \leftrightarrow secondary									
Insulation resistance	R_{IS}	$\geq 500\text{M}\Omega$ (at DC500V), primary \leftrightarrow secondary									
Ambient operation temperature	T_A	$-30^{\circ}\text{C} \sim +80^{\circ}\text{C}$									
Ambient storage temperature	T_S	$-40^{\circ}\text{C} \sim +85^{\circ}\text{C}$									

¹ After removal of core hysteresis — ² Without offset — ³ Time between 10% input current full scale and 90% of sensor output full scale — ⁴ Without Thermal drift of offset

Electrical Performances

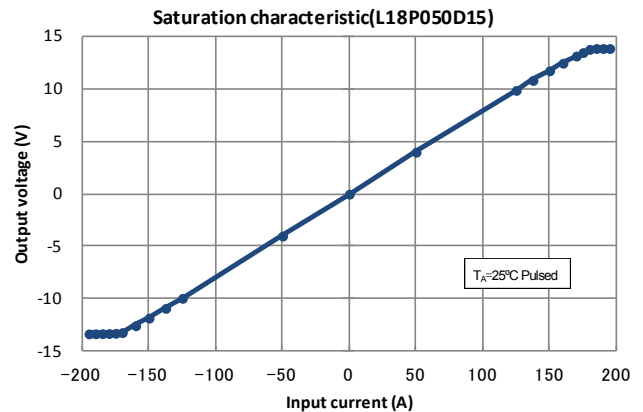
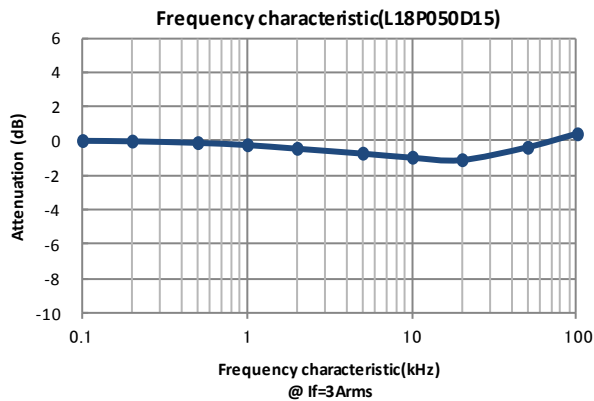

Hall Effect Current Sensors L18P***D15 Series

Mechanical dimensions

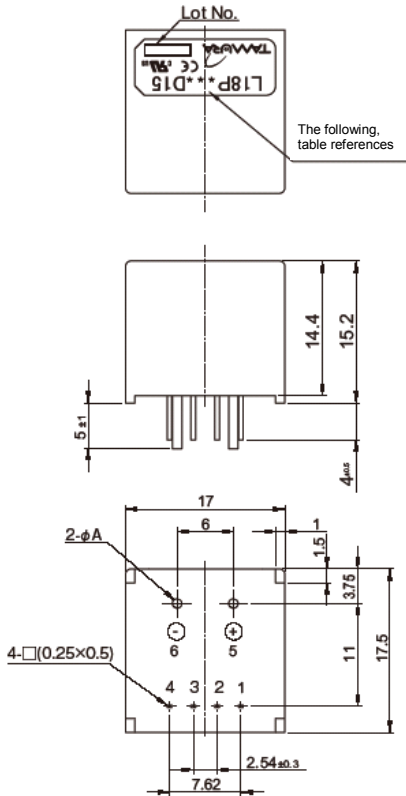

Terminal Number:

- 1: $-V_{CC}(-15V)$
- 2: GND
- 3: $+V_{CC}(+15V)$
- 4: V_{OUT}
- 5: Primary input current (+)
- 6: Primary input current (-)

Current	XXX	ϕA
3A	003	$\phi 0.6$
5A	005	$\phi 0.8$
10A	010	$\phi 1.1$
15A	015	$\phi 1.4$
20A	020	$\phi 1.6$
25A	025	$\phi 1.6$
30A	030	$\phi 1.6$

NOTES

1. Unit is mm
2. Tolerance is 0.5mm
3. Cover is optional parts.

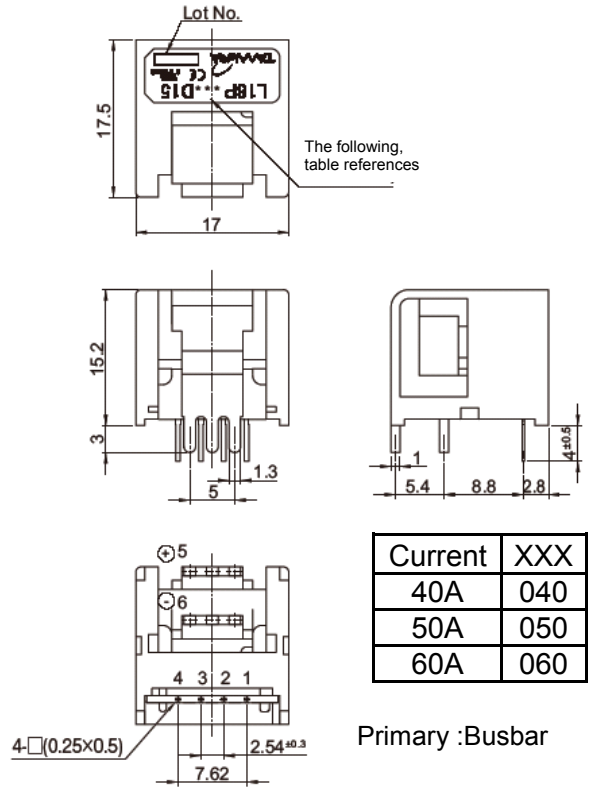

Current	XXX
40A	040
50A	050
60A	060

Primary :Busbar

Electrical connection diagram

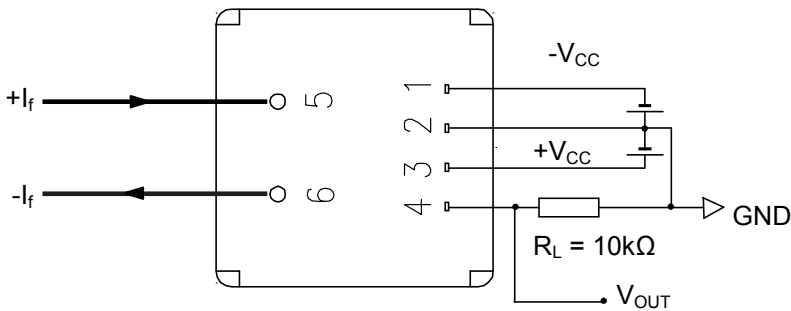

UL Standard

UL 508 , CSA C22.2 No.14
(UL FILE No.E243511)



- For use in Pollution Degree 2 Environment.
- Maximum Surrounding air temperature rating, 80°C.

Package & Weight Information

nominal current	Weight	Pcs/box	Pcs/carton	Pcs/pallet
10A..60A	8g	100	600	12000
3A , 5A	8g	50	1200	28800

Looking for pricing, stock, or lifecycle information?

Click below to explore more details on WIN SOURCE:

-  [View L18P005D15 on WIN SOURCE](#)
-  [Tamura Information](#)

Optimize Your Supply Chain with WIN SOURCE Solutions

-  Global Sourcing Solution
-  Obsolete Management
-  Cost Control Management
-  Shortage Management
-  Alternative Solution
-  Excess Inventory Management