



**THE DATASHEET OF  
KXTH9-2083-FR**





## ± 2.5g Tri-axis Analog Accelerometer Specifications

PART NUMBER:

KXTH9-2083  
Rev. 3  
Sep-2011

### Product Description

The KXTH9-2083 is a Tri-axis, silicon micromachined accelerometer with a full-scale output range of  $\pm 2.5g$  (24.5 m/s/s). The sense element is fabricated using Kionix's proprietary plasma micromachining process technology. Acceleration sensing is based on the principle of a differential capacitance arising from acceleration-induced motion of the sense element, which further utilizes common mode cancellation to decrease errors from process variation, temperature, and environmental stress. The sense element is hermetically sealed at the wafer level by bonding a second silicon lid wafer to the device using a glass frit. A separate ASIC device packaged with the sense element provides signal conditioning and self-test. The accelerometer is delivered in a 3 x 3 x 0.9mm Land Grid Array (LGA) plastic package operating from a 1.8 – 3.6 V DC supply. The KXTH9 features a factory programmable low pass filter.

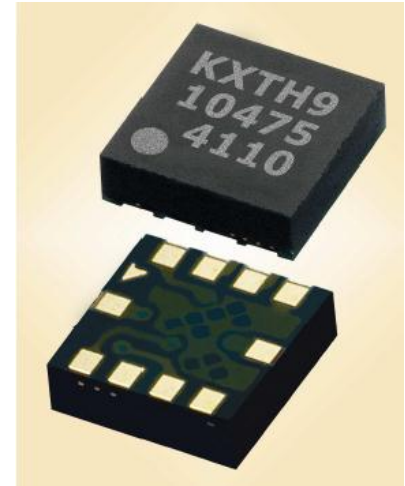

There are 2 factory programmable modes of operation for the KXTH9:

**Mode 00** – The PD pin must be **high** for normal operation and **low** for power shutdown.

**Mode 01** – The PD pin must be **low** for normal operation and **high** for power shutdown.

The KXTH9-2083 is factory programmed to be in MODE 01.



# ± 2.5g Tri-axis Analog Accelerometer Specifications

PART NUMBER:

KXTH9-2083  
Rev. 3  
Sep-2011

## Functional Diagram

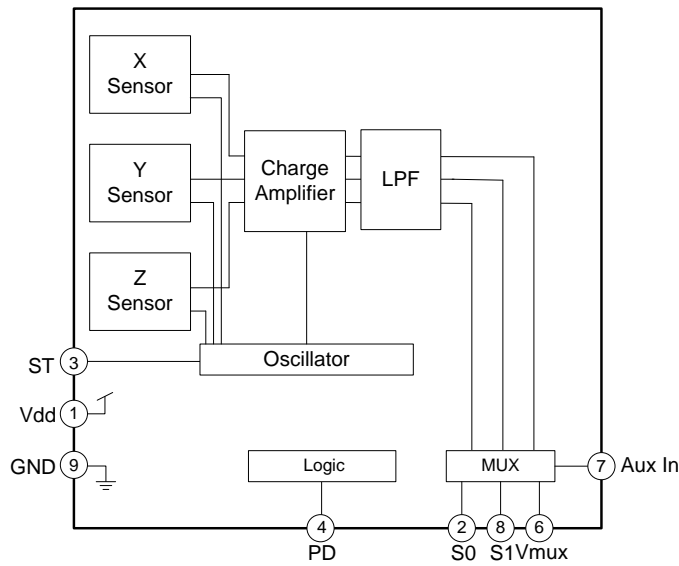



# ± 2.5g Tri-axis Analog Accelerometer Specifications

**PART NUMBER:**

**KXTH9-2083  
Rev. 3  
Sep-2011**

## Product Specifications

**Table 1. Mechanical**

(specifications are for operation at 2.5V and T = 25C unless stated otherwise)

Parameters	Units	Min	Typical	Max
Operating Temperature Range	°C	-40	-	85
Zero-g Offset	V	1.19	1.25	1.31
Zero-g Offset Variation from RT over Temp.	mg/°C		0.6	
Sensitivity	mV/g	388	400	412
Sensitivity Variation from RT over Temp.	%/°C		0.01 (xy) 0.04 (z)	
Offset Ratiometric Error ( $V_{dd} = 2.5V \pm 5\%$ )	%		0.3	
Sensitivity Ratiometric Error ( $V_{dd} = 2.5V \pm 5\%$ )	%		0.6 (xy) 0.3 (z)	
Self Test Output change on Activation	g	1 1 0.5	1.5 (x) 1.4 (y) 1 (z)	2 1.8 1.6
Mechanical Resonance (-3dB) <sup>1</sup>	Hz		3500 (xy) 1800 (z)	
Non-Linearity	% of FS		0.1	
Cross Axis Sensitivity	%		2	
Noise Density (on filter pins)	µg / √Hz		150	

Notes:

1. Resonance as defined by the dampened mechanical sensor.



## ± 2.5g Tri-axis Analog Accelerometer Specifications

**PART NUMBER:**

**KXTH9-2083  
Rev. 3  
Sep-2011**

**Table 2. Electrical**

(specifications are for operation at 2.5V and T = 25C unless stated otherwise)

Parameters		Units	Min	Typical	Max
Supply Voltage (V <sub>dd</sub> )	Operating	V	1.8	2.5	3.6
Current Consumption	Operating (full power)	μA	150	350	550
	Standby	μA		5	
Input Low Voltage		V			0.2 * V <sub>dd</sub>
Input High Voltage		V	0.8 * V <sub>dd</sub>		
Power Up Time <sup>1</sup>		ms	-	5*R <sub>out</sub> *C	-
Mux Switching Time <sup>2</sup>		μs			5
Bandwidth (-3dB) <sup>3</sup>		Hz	40	50	60

Notes:

1. Power up time is determined by 5 times the RC time constant of the factory programmed or user defined low pass filter.
2. Mux Switching Time is defined as a transition from 10% to 90% with a 10pF load.
3. Factory programmable to have a switched capacitor low pass filter at 2kHz, 1kHz, 500Hz, 100Hz, 50Hz, or no low pass filter. Optionally, the user can define with external capacitors. Maximum defined by the frequency response of the sensors.



## ± 2.5g Tri-axis Analog Accelerometer Specifications

PART NUMBER:

KXTH9-2083  
Rev. 3  
Sep-2011

Table 3. Environmental

Parameters		Units	Min	Typical	Max
Supply Voltage ( $V_{dd}$ )	Absolute Limits	V	-0.3	-	6.0
Operating Temperature Range		°C	-40	-	85
Storage Temperature Range		°C	-55	-	150
Mech. Shock (powered and unpowered)		g	-	-	5000 for 0.5ms 10000 for 0.2ms
ESD	HBM	V	-	-	3000



Caution: ESD Sensitive and Mechanical Shock Sensitive Component, improper handling can cause permanent damage to the device.



This product conforms to Directive 2002/95/EC of the European Parliament and of the Council of the European Union (RoHS). Specifically, this product does not contain lead, mercury, cadmium, hexavalent chromium, polybrominated biphenyls (PBB), or polybrominated diphenyl ethers (PBDE) above the maximum concentration values (MCV) by weight in any of its homogenous materials. Homogenous materials are "of uniform composition throughout."



This product is halogen-free per IEC 61249-2-21. Specifically, the materials used in this product contain a maximum total halogen content of 1500 ppm with less than 900-ppm bromine and less than 900-ppm chlorine.

### Soldering

Soldering recommendations are available upon request or from [www.kionix.com](http://www.kionix.com).



# ± 2.5g Tri-axis Analog Accelerometer Specifications

**PART NUMBER:**

**KXTH9-2083**  
Rev. 3  
Sep-2011

## Application Schematic

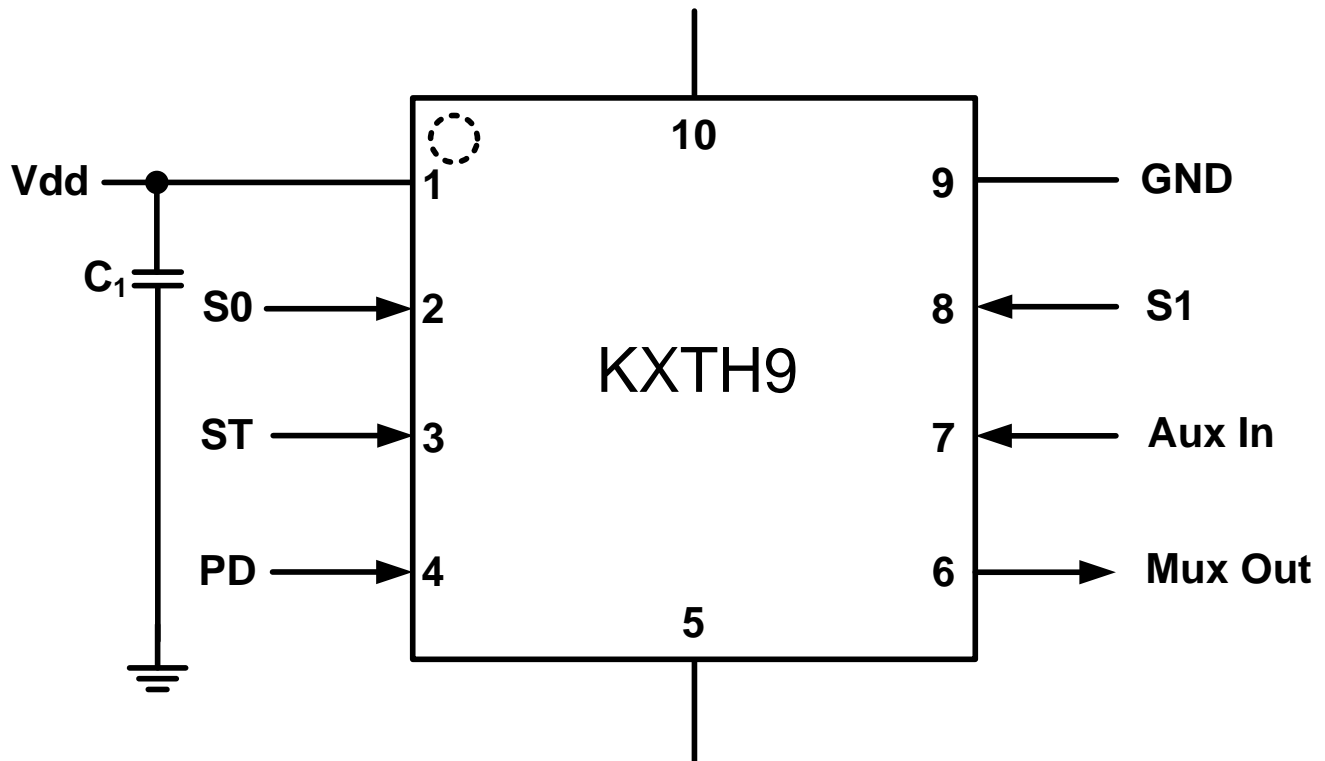

**Table 4. KXTH9 Pin Descriptions**

Pin	Name	Description
1	Vdd	The power supply input. Decouple this pin to ground with a 0.1uF ceramic capacitor (C <sub>1</sub> ).
2	S0	MUX selector 0 (See Output Select Table).
3	ST	Self Test: <b>High</b> - Device is in self-test mode; <b>Low</b> - Normal operation
4	PD	Power shutdown: <b>Low</b> - Normal operation; <b>High</b> - Device is in standby, power down mode
5	NC	Not Connected Internally (can be connected to Vdd or GND)
6	Mux Out	Multiplexed analog output.
7	Aux In	Auxiliary input for multiplexer. Connect to Vdd or Ground if not used.
8	S1	MUX selector 1 (See Output Select Table).
9	GND	Ground
10	NC	Not Connected Internally (can be connected to Vdd or GND)



## ± 2.5g Tri-axis Analog Accelerometer Specifications

PART NUMBER:

KXTH9-2083  
Rev. 3  
Sep-2011

### Application Design Equations

The bandwidth is determined by a factory programmable switched capacitor filter. The filter can be set at the factory to be 2kHz, 1kHz, 500Hz, 100Hz, 50Hz, or no low pass filter. Alternatively, bandwidth can be reduced by addition of a capacitor on the output pins 5, 6, and 7 according to the equation:

$$C_2 = C_3 = C_4 = \frac{4.97 \times 10^{-6}}{f_{BW}}$$

### USING THE MULTIPLEXED OUTPUT OF THE KXTH9

#### *Multiplexer Data Select*

The KXTH9 features an integrated 4-channel multiplexer. This feature reduces system MCU requirements to only 1 ADC and 2 digital I/O's. The KXTH9 uses two select inputs (S0, S1) to control the data flow from Vmux. When a microprocessor toggles the select inputs, the desired output is attained based on the select table. Note that logic 0 is GND and logic 1 is Vdd.

S1	S0	Vmux
0	0	X Output
0	1	Y Output
1	0	Z Output
1	1	Aux In

Output Select Table

#### *Data Sampling Rate*

When operating in its multiplexed mode, the KXTH9 has the ability to achieve very high data sampling rates. Internally, the sensor elements (X, Y, and Z) are sequentially sampled in a "round robin" fashion at a rate of 32 kHz per axis. Combine this high sensor element sampling rate with the short 5 μs settling time of the integrated multiplexer, and the user can achieve a performance very close to that of the 3 separate analog outputs. This is more than sufficient to eliminate any aliasing in the final application since the KXTH9 will be operating with a typical bandwidth of ~50Hz and a maximum of 1000Hz.



# ± 2.5g Tri-axis Analog Accelerometer Specifications

PART NUMBER:

KXTH9-2083  
Rev. 3  
Sep-2011

## Test Specifications



### *Special Characteristics:*

These characteristics have been identified as being critical to the customer. Every part is tested to verify its conformance to specification prior to shipment.

**Table 5. Test Specifications**

Parameter	Specification	Test Conditions
Zero-g Offset @ RT	1.25 +/- 0.06 V	25C, Vdd = 2.5 V
Sensitivity @ RT	400 +/- 12 mV/g	25C, Vdd = 2.5 V
Current Consumption -- Operating	150 <= Idd <= 550 uA	25C, Vdd = 2.5 V



# ± 2.5g Tri-axis Analog Accelerometer Specifications

PART NUMBER:  
KXTH9-2083  
Rev. 3  
Sep-2011

## Package Dimensions and Orientation

3 x 3 x 0.9 mm LGA

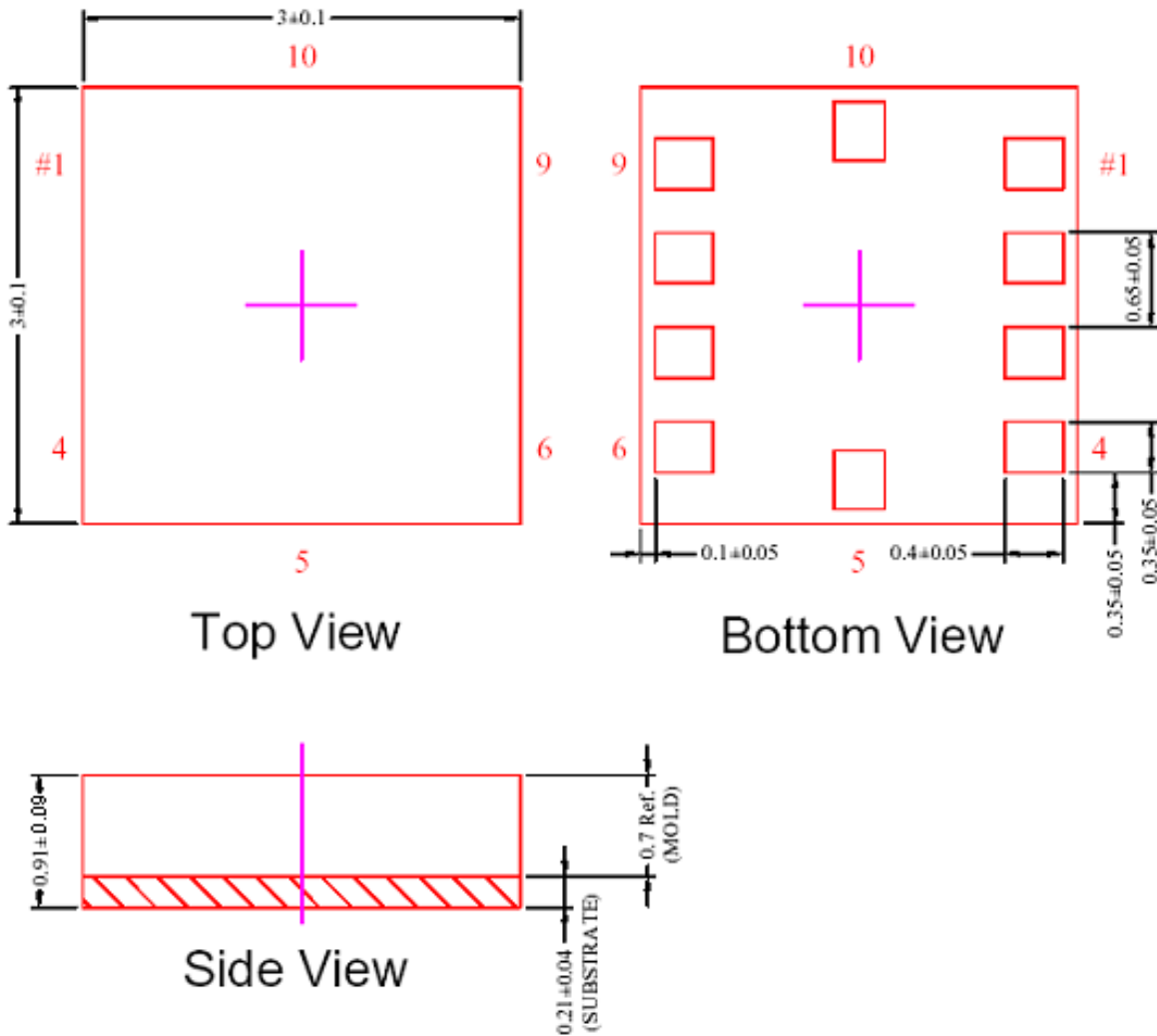

All dimensions and tolerances conform to ASME Y14.5M-1994



# ± 2.5g Tri-axis Analog Accelerometer Specifications

PART NUMBER:

KXTH9-2083  
Rev. 3  
Sep-2011

## Orientation

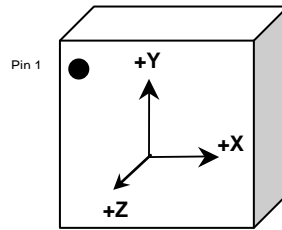

When device is accelerated in +X, +Y or +Z direction, the corresponding output will increase.

### Static X/Y/Z Output Response versus Orientation to Earth's surface (1-g):

Position	1	2	3	4	5	6
Diagram						
X	1.25 V	1.65 V	1.25 V	0.85 V	1.25 V	1.25 V
Y	1.65 V	1.25 V	0.85 V	1.25 V	1.25 V	1.25 V
Z	1.25 V	1.25 V	1.25 V	1.25 V	1.65 V	0.85 V
X-Polarity	0	+	0	-	0	0
Y-Polarity	+	0	-	0	0	0
Z-Polarity	0	0	0	0	+	-

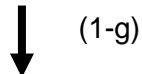

Earth's Surface

	<b>± 2.5g Tri-axis Analog Accelerometer Specifications</b>	<b>PART NUMBER:</b>  <b>KXTH9-2083</b> <b>Rev. 3</b> <b>Sep-2011</b>
---	--	--

### Revision History

REVISION	DESCRIPTION	DATE
1	Initial Release	25-Aug-2010
2	Added product photo, corrected naming of Pin 6 on Table 4.	03-Mar-2011
3	Update Self Test Specifications to include Min and Max	09-Sep-2011

"Kionix" is a registered trademark of Kionix, Inc. Products described herein are protected by patents issued or pending. No license is granted by implication or otherwise under any patent or other rights of Kionix. The information contained herein is believed to be accurate and reliable but is not guaranteed. Kionix does not assume responsibility for its use or distribution. Kionix also reserves the right to change product specifications or discontinue this product at any time without prior notice. This publication supersedes and replaces all information previously supplied.

## Looking for pricing, stock, or lifecycle information?

Click below to explore more details on WIN SOURCE:

 [View KXTH9-2083-FR on WIN SOURCE](#)

 [Kionix Inc. Information](#)

## Optimize Your Supply Chain with WIN SOURCE Solutions

-  Global Sourcing Solution
-  Obsolete Management
-  Cost Control Management
-  Shortage Management
-  Alternative Solution
-  Excess Inventory Management