



**THE DATASHEET OF  
KTD2505RECD-TR**



## 38V High Efficiency Step-Up LED Driver with PWM/ExpressWire™

### Features

- Wide output range: up to 10 series LEDs
- Integrated 40V high current switch (1.2A limit)
- VIN: 2.7V~5.5V
- High efficiency PWM converter (up to 88%)
- Low 200mV feedback voltage
- Single-wire interface dual method dimming:
  - ExpressWire Digital Control
  - PWM dimming
- High accuracy across full load range
- LED open-circuit (OVP) protection: 38V
- High switching frequency: 1.2MHz
- Simple, small solution size
- Integrated Softstart
- < 1  $\mu$ A shutdown current
- Small TDFN22-6 Package
- RoHS and Green compliant
- -40°C to +85°C Temperature Range

### Brief Description

KTD2505R is a versatile constant current LED driver with a high efficiency DC-DC step up “boost” converter architecture. The low-side power MOSFET is integrated in the device, minimizing the total number of external components. Unique technology and high 1.2A current limit allow KTD2505R to drive up to 38V output (10 LEDs in series). It can also maximize the current capability while achieving high conversion efficiency. The optimized 1.2MHz switching frequency results in reduced conduction loss and small external component size. A single wire interface is integrated which can be used for PWM dimming or ExpressWire dimming in 32 steps.

Various protection features are built into KTD2505R, including cycle-by-cycle input current limit protection, LED open-circuit (output over voltage) protection and thermal shutdown protection. The leakage current in shutdown mode is less than 1 $\mu$ A.

KTD2505R is available in an RoHS and Green compliant 6-lead TDFN 2x2mm package.

### Applications

- LED backlighting
- Mobile Phones
- Handheld Devices
- Digital Photo Frames
- Automotive Navigation

### Typical Application

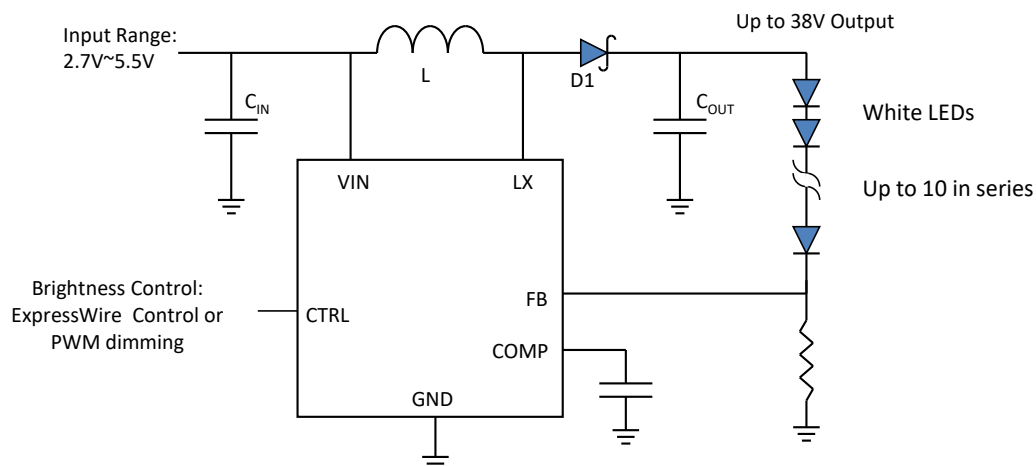

## Pin Descriptions

### TDFN22-6

Pin #	Name	Function
1	FB	Output feedback pin regulated at 0.2V
2	COMP	Converter compensation pin. Connect a capacitor from this pin to GND for loop compensation.
3	GND	Converter/IC ground
4	LX	Converter switching node. The inductor should be connected between VIN and LX. This pin is also used to sense the output for open-load protection.
5	CTRL	IC control pin. Can be used to enable/disable the IC, as well as to program the output current using ExpressWire or PWM dimming. This pin is bidirectional when the acknowledge programming bit is set, as it asserts an open drain acknowledge signal when a valid ExpressWire command is given.
6	VIN	IC supply voltage

**TDFN22-6  
Top View:**

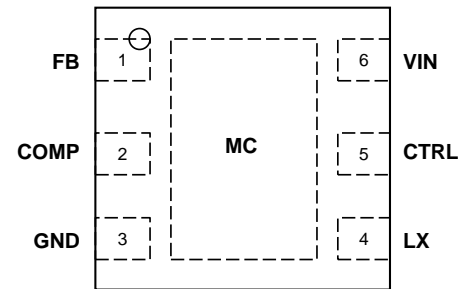

## Absolute Maximum Ratings<sup>1</sup>

(T<sub>A</sub> = 25°C unless otherwise noted)

Symbol	Description	Value	Units
VIN	Input voltage	-0.3 to 6.0	V
LX	Switching node <sup>2</sup>	-1.2 to 42	V
FB, CTRL, COMP	Other pins	-0.3 to VIN+0.3	V
T <sub>J</sub>	Operating Temperature Range	-40 to 150	°C
T <sub>s</sub>	Storage Temperature Range	-65 to 150	°C
T <sub>LEAD</sub>	Maximum Soldering Temperature (at leads, 10 sec)	300	°C
ESD	HBM electrical static discharge	2.0	kV

1. Stresses above those listed in Absolute Maximum Ratings may cause permanent damage to the device. Functional operation at conditions other than the operating conditions specified is not implied. Only one Absolute Maximum rating should be applied at any one time.
2. LX Switching node can tolerate Absolute Maximum negative voltage rating with maximum 100mA flowing from GND to LX pin.

## Thermal Capabilities

Symbol	Description	Value	Units
<b>TDFN22-6</b>			
θ <sub>JA</sub>	Thermal Resistance – Junction to Ambient <sup>3</sup>	65	°C/W
P <sub>D</sub>	Maximum Power Dissipation at T <sub>A</sub> ≤ 25°C	1.54	W
ΔP <sub>D</sub> /°C	Derating Factor Above T <sub>A</sub> = 25°C	-15.4	mW/°C

3. Junction to Ambient thermal resistance is highly dependent on PCB layout. Values are based on thermal properties of the device when soldered to an EV board.

## Ordering Information

Part Number	OVP Threshold (nominal)	Marking	Operating Temperature	Package
KTD2505RECD-TR	38V	EJYYZ <sup>4</sup>	-40°C to +85°C	TDFN22-6

4. "YYZ" is the date code and assembly code.

## Electrical Characteristics<sup>5</sup>

Unless otherwise noted, the *Min* and *Max* specs are applied over the full operation temperature range of -40°C to +85°C, while *Typ* values are specified at room temperature (25°C). VIN = 3.6V.

Symbol	Description	Conditions	Min	Typ	Max	Units
<b>IC Supply</b>						
V <sub>IN</sub>	Input operating range		2.7		5.5	V
UVLO	Input under voltage lockout	Rising edge		2.5	2.65	V
UVLO <sub>HYST</sub>	UVLO hysteresis			0.15		V
I <sub>Q</sub>	IC quiescent current (non-switching)	FB = 0.4V		0.37	0.6	mA
	IC operating current (switching)	FB = 0V		1.1	2.0	mA
I <sub>SHDN</sub>	V <sub>IN</sub> pin shutdown current	CTRL = GND		0.1	1.0	μA
<b>Step-Up Converter</b>						
V <sub>FB</sub>	FB pin accuracy		184	200	216	mV
V <sub>FB_DATA6</sub>	FB pin accuracy at Data 6	V <sub>FB</sub> = 20mV	14	20	26	mV
I <sub>FB</sub>	FB pin bias current				0.1	μA
R <sub>DS(ON)</sub>	NMOS on-resistance	T <sub>A</sub> = 25°C		0.65	1.0	Ω
I <sub>LX</sub>	LX pin leakage current			0.1		μA
I <sub>LIM</sub>	Peak NMOS current limit			1.2		A
F <sub>SW</sub>	Oscillator frequency			1.2		MHz
D <sub>max</sub>	Maximum duty cycle		92	96		%
V <sub>OVP</sub>	Over voltage threshold	Measured at LX pin		38		V
t <sub>STARTUP</sub>	Start-up time			14		ms

5. KTD2505R is guaranteed to meet performance specifications over the -40°C to +85°C operating temperature range by design, characterization and correlation with statistical process controls.

## Electrical Characteristics (continued)<sup>6</sup>

Symbol	Description	Conditions	Min	Typ	Max	Units
<b>Control</b>						
V <sub>TH-L</sub>	CTRL logic low threshold				0.4	V
V <sub>TH-H</sub>	CTRL logic high threshold		1.4			V
R <sub>CTRL</sub>	CTRL pull down resistor		300	600	1200	kΩ
t <sub>off</sub>	CTRL pulse width to shutdown	CTRL high to low	2.5			ms
t <sub>EW_DET</sub>	ExpressWire detection time <sup>7</sup>		260			μs
t <sub>EW_DELAY</sub>	ExpressWire detection delay		100			μs
t <sub>EW_WIN</sub>	ExpressWire detection window time		1			ms
t <sub>START</sub>	Start time of programming stream		2			μs
t <sub>EOS</sub>	End time of programming stream		2		360	μs
t <sub>H_LB</sub>	High time low bit	Logic 0	2		180	μs
t <sub>L_LB</sub>	Low time low bit	Logic 0	2 x t <sub>H_LB</sub>		360	μs
t <sub>H_HB</sub>	High time high bit	Logic 1	2 x t <sub>L_HB</sub>		360	μs
t <sub>L_HB</sub>	Low time high bit	Logic 1	2		180	μs
V <sub>ACK</sub>	Acknowledge output voltage low	Open drain, 15kΩ pull-up from CTRL to VIN			0.4	V
t <sub>ACK_VAL</sub>	Acknowledge valid time	Note 8			2	μs
t <sub>ACK</sub>	Duration of acknowledge condition	Note 8			512	μs
f <sub>DIM</sub>	Recommended PWM dimming frequency		7		100	kHz
D <sub>DIM</sub>	PWM dimming duty cycle resolution	f <sub>DIM</sub> = 20kHz	2			%
T <sub>PWM_ON</sub>	PWM dimming on-time	f <sub>DIM</sub> = 20kHz	1			μs
		f <sub>DIM</sub> = 30kHz	1			
<b>Thermal Shutdown</b>						
T <sub>J-TH</sub>	IC junction thermal shutdown threshold			150		°C
	IC junction thermal shutdown hysteresis			15		°C

6. KTD2505R is guaranteed to meet performance specifications over the -40°C to +85°C operating temperature range by design, characterization and correlation with statistical process controls.

7. To select ExpressWire programming, the CTRL pin must be low for more than t<sub>EW\_DET</sub> during t<sub>EW\_WIN</sub>

8. Acknowledge condition is active 0, this condition will only be applied in case the RFA bit is set. The open drain output requires a pull-up resistor.

## Typical Characteristics

$V_{IN} = 3.6V$ ,  $I_{LED} = 20mA$ , 10-Series LEDs,  $L = 22\mu H$ ,  $C_{IN} = 4.7\mu F$ ,  $C_{OUT} = 1\mu F$ ,  $C_{COMP} = 0.22\mu F$ ,  $Temp = 25^{\circ}C$  unless otherwise specified.

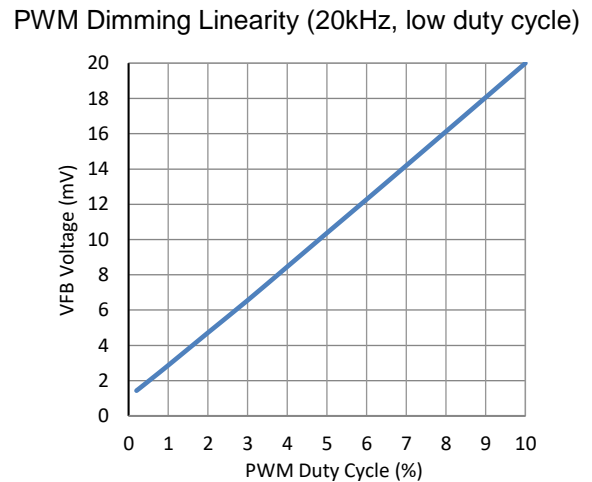
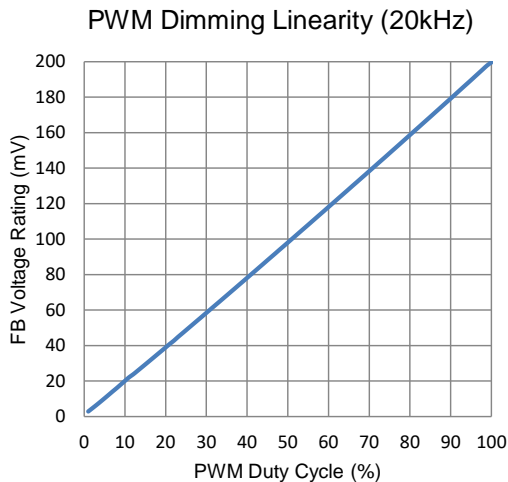
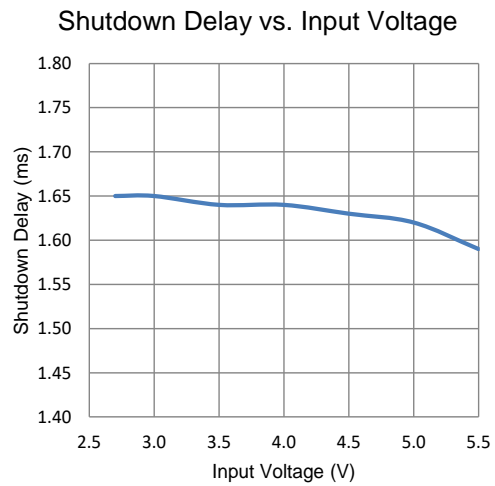
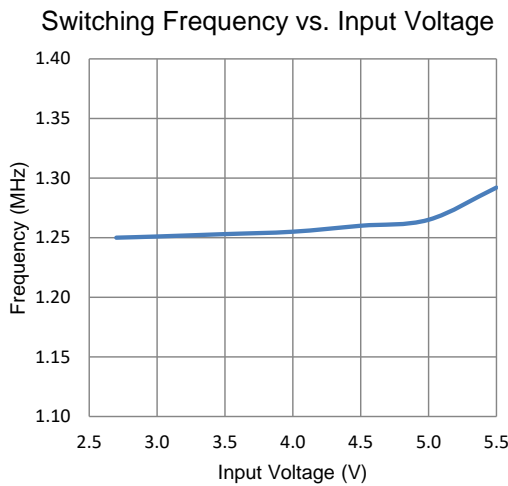
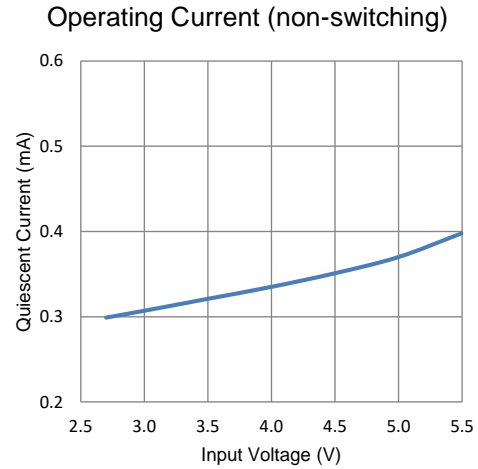
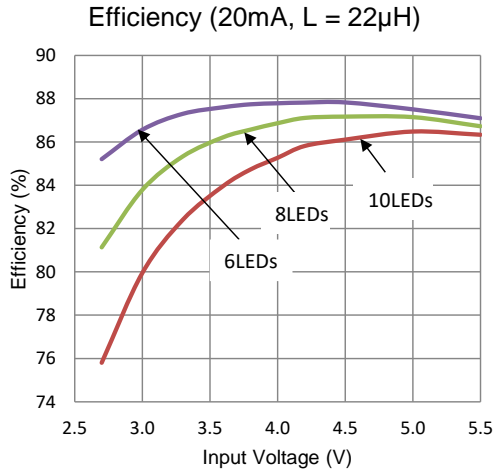

## Typical Characteristics (continued)

### Soft Start Turn ON

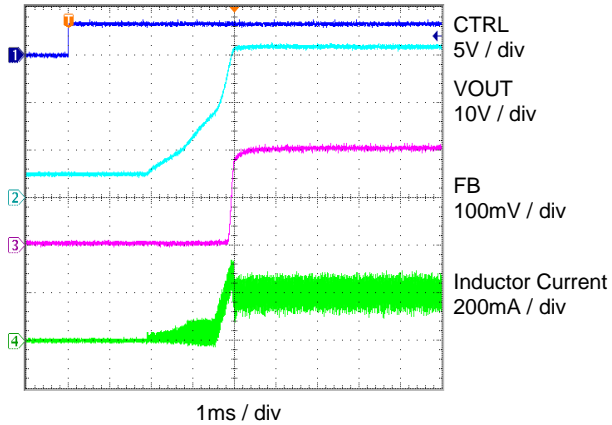

### Shutdown

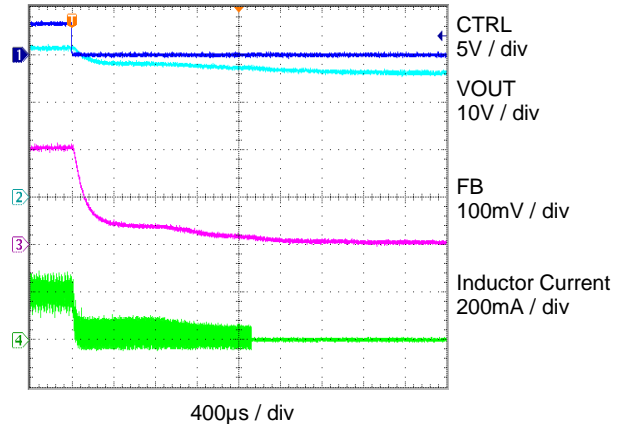

### Steady State Switching

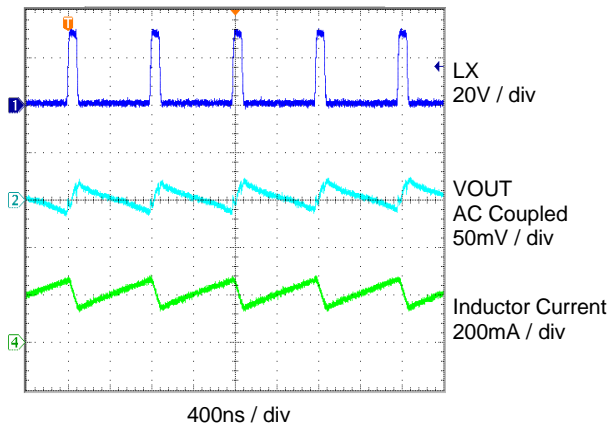

### Turn ON with LED Open (OVP)

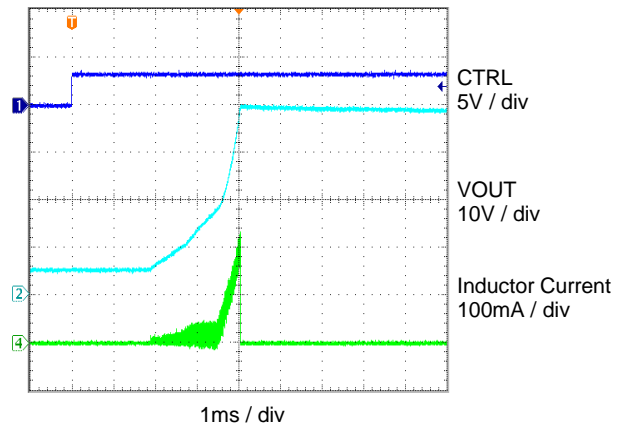

### PWM Dimming (20kHz, 50% Duty Cycle)

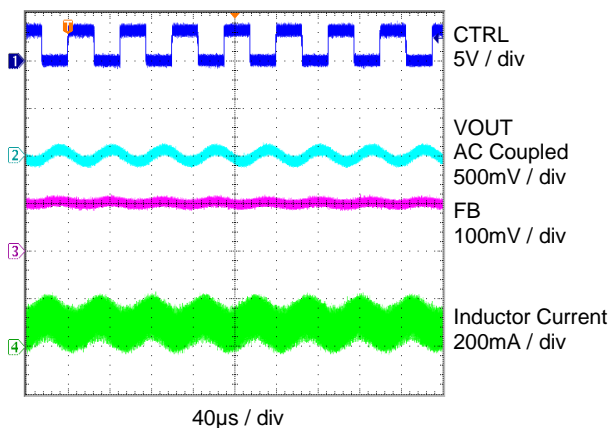

### ExpressWire Interface Programming Data Steps

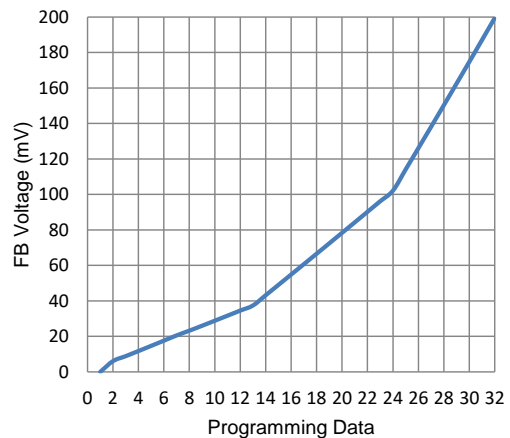

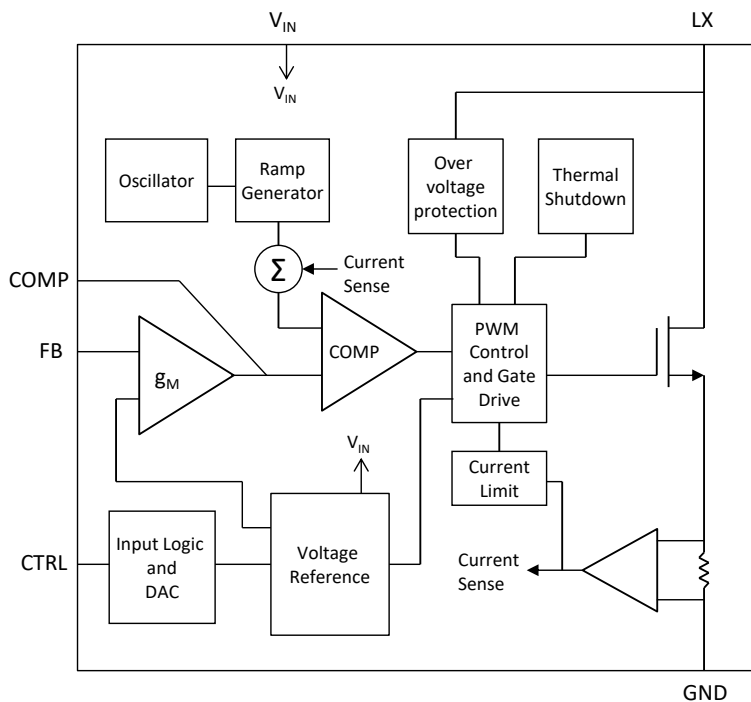
**Functional Block Diagram**

**Functional Description**

KTD2505R uses a constant-frequency current-mode boost converter architecture to control the LED current by regulating the feedback voltage. Please refer to the functional block diagram above for an explanation of KTD2505R operation. The beginning of each cycle turns on the Power MOSFET. A slope compensation ramp is added to the output of the current sense amplifier and the result is fed into the positive input of the comparator (COMP). When this voltage goes above the output voltage of the error amplifier ( $g_M$ ), the Power MOSFET is turned off. The voltage at the output of the  $g_M$  block amplifies the difference between the reference voltage and the feedback voltage (FB), so that FB voltage can be regulated to the reference voltage.

KTD2505R has built-in soft-start to limit the inrush current during startup and to limit the amount of overshoot on the output. Protection features in the KTD2505R include over-voltage protection (OVP), cycle-by-cycle current limit protection and thermal shutdown.

The control interface can be used for either PWM dimming or ExpressWire single-wire control. In ExpressWire mode, it accepts a data set into the CTRL pin to program the reference voltage. The data contains 5 bits, yielding 32 different current levels. In PWM dimming mode, PWM pulses are provided at CTRL pin to program the reference voltage according to the duty cycle of the PWM signal, so that the LED current is proportional to the PWM duty cycle. The simplest control method is accomplished by toggling CTRL between high and low to program the output current between  $I_{MAX}$  and 0mA.  $I_{MAX}$  is set by the resistor connected between FB and GND. Please see LED Maximum Current Setting section in this document to determine the proper resistor value.

KTD2505R has internal OVP circuitry to prevent IC damage during open-LED condition. When an LED fails open, the feedback voltage falls to zero, forcing the boost converter to operate in maximum duty cycle mode, ramping up the output voltage. LX pin's peak voltage also goes up with the output voltage. KTD2505R monitors the LX pin's peak voltage continuously and if it exceeds OVP threshold for at least 8 switching cycles, KTD2505R will stop switching and the output voltage will drop down close to the input voltage. This OVP protection is latched and can be reset by either toggling the CTRL pin or powering down and powering up the IC.

## Dimming Mode Selection

KTD2505R's CTRL pin can be used for both PWM dimming and ExpressWire dimming. The dimming mode is selected when the IC is enabled. By default, the dimming mode is PWM dimming. To use ExpressWire programming, the first few pulses at CTRL pin should meet the following timing requirement shown in Figure 1.

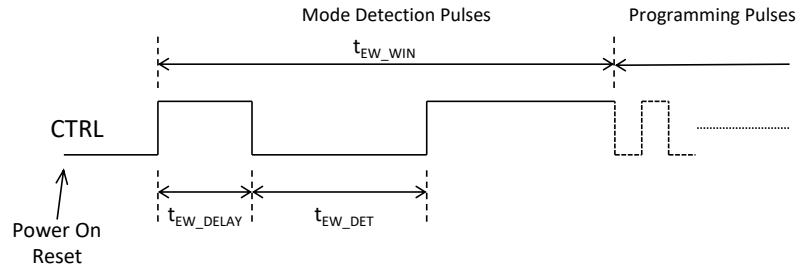

**Figure 1. Dimming Mode Selection Pulses**

1. After the IC is powered up, CTRL's 1<sup>st</sup> pulse high width (ExpressWire delay time)  $t_{EW\_DELAY}$  should be greater than 100 $\mu$ s.
2. CTRL's 1<sup>st</sup> pulse low width (ExpressWire detection time)  $t_{EW\_DET}$  should be greater than 260 $\mu$ s.
3. The CTRL pin must be low for more than the ExpressWire detection time before the ExpressWire detection window  $t_{EW\_WIN}$ , expires. ExpressWire detection window starts from the first CTRL pin low to high transition.

Once CTRL's initial pulses meet the above timing requirement, the IC enters ExpressWire dimming mode. Then the user can continue to send programming pulses to adjust the reference voltage. Once ExpressWire dimming mode is selected, the IC can only change to PWM dimming mode through one of the following two ways:

1. Driving CTRL low for more than 2.5ms to shut down the IC, then sending PWM signal (frequency range 5kHz~100kHz) at CTRL will restart the IC. This method preserves the maximum reference voltage in PWM dimming mode set by the previous ExpressWire dimming mode, and pulling CTRL low to shut down the IC will not reset the maximum reference voltage.
2. Removing power from the IC and then reapplying power to perform power-on reset, then sending PWM signal (frequency range 5kHz~100kHz) at CTRL will restart the IC. By doing this way, the maximum reference voltage at PWM dimming mode is reset to the default 200mV, because power-on reset will reset the maximum reference voltage.

## PWM Brightness Dimming using CTRL pin

After the IC is power reset, driving the CTRL pin continuously high will result in the FB voltage regulated at 200mV nominal. However, the CTRL pin allows a PWM signal to reduce this regulation voltage to control LED brightness dimming. The relationship between the duty cycle and FB voltage is given by the equation:

$$V_{FB} = DC \times 200mV$$

where DC is the duty cycle of the PWM signal applied to CTRL pin, and 200mV is the default internal reference voltage.

KTD2505R internally applies the PWM input signal to the 200mV reference voltage which creates a 200mV (peak) signal with the same duty cycle as the PWM input signal. This is fed into an RC low pass filter which gives a DC voltage proportional to the duty cycle of the PWM signal. This voltage is connected to the error amplifier as the reference voltage for the FB pin regulation. This means the PWM signal controls the current via translation to a DC signal to accomplish analog dimming. The advantage of this method is the elimination of audible noise which can occur when the LED current is pulsed at the frequency of the PWM dimming signal. For best performance, the PWM dimming frequency should be in the range of 5kHz to 100kHz. The minimum frequency

requirement is determined by the ExpressWire detection delay and detection time specification in described in Dimming Mode Selection.

### ExpressWire dimming using CTRL pin

The CTRL pin features a single wire digital interface to program LED brightness. KTD2505R uses the ExpressWire protocol for digital dimming, which can program the FB voltage to any of the 32 steps. The step increment increases in three tiers to simulate a logarithmic curve for the brightness steps, shown in Table 1. The default step is full scale when the device is first enabled (VFB = 200 mV). The programmed reference voltage is stored in an internal register. A power reset will bring the value back to the default setting; however, using CTRL to shut down the IC will not reset the internal register.

**Table 1. FB Voltage Programing Table**

DATA	FB Voltage (mV)	D4	D3	D2	D1	D0
0	0	0	0	0	0	0
1	6.0	0	0	0	0	1
2	9.0	0	0	0	1	0
3	11.9	0	0	0	1	1
4	14.9	0	0	1	0	0
5	17.9	0	0	1	0	1
6	20.9	0	0	1	1	0
7	23.9	0	0	1	1	1
8	26.9	0	1	0	0	0
9	29.9	0	1	0	0	1
10	32.8	0	1	0	1	0
11	35.8	0	1	0	1	1
12	38.8	0	1	1	0	0
13	44.8	0	1	1	0	1
14	50.7	0	1	1	1	0
15	56.7	0	1	1	1	1
16	62.7	1	0	0	0	0
17	68.7	1	0	0	0	1
18	74.6	1	0	0	1	0
19	80.6	1	0	0	1	1
20	86.6	1	0	1	0	0
21	92.5	1	0	1	0	1
22	98.5	1	0	1	1	0
23	104.5	1	0	1	1	1
24	116.4	1	1	0	0	0
25	128.4	1	1	0	0	1
26	140.3	1	1	0	1	0
27	152.2	1	1	0	1	1
28	164.2	1	1	1	0	0
29	176.1	1	1	1	0	1
30	188.1	1	1	1	1	0
31	200.0	1	1	1	1	1

KTD2505Rs ExpressWire programming protocol is a simple single-wire interface used to scale the FB voltage. The interface is based on a master-slave structure, where the master is typically a microcontroller and in this case the slave is KTD2505R. The protocol consists of a device specific address byte and a data byte, shown in Figure 2 and Table 2. The device specific address byte is factory programmed to 72 hex for KTD2505R. The data byte consists of five bits for control, two bits for register address, and one bit RFA for acknowledge. If the RFA bit is set to logic 1, it signals the Request for Acknowledge condition. The acknowledge signal is provided via the CTRL pin's open-drain output acting in bi-directional mode, and is only given if the protocol was received correctly. The control interface can automatically detect bit rates between 1.7kBit/sec and 160kBit/sec.

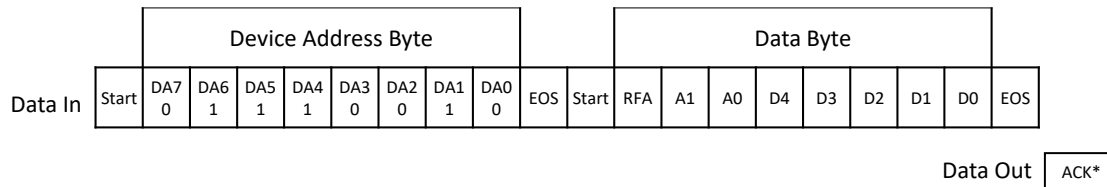

**Figure 2. Single Wire ExpressWire Protocol Overview**

\*Note: Ack open-drain signal is asserted if RFA bit is set high and CTRL line has a host pull-up resistor

**Table 2. ExpressWire Protocol Bit Description**

BYTE	BIT Number	Name	Direction	Description
Device Address Byte 72 hex	7	DA7	INPUT	0 (MSB device address)
	6	DA6		1
	5	DA5		1
	4	DA4		1
	3	DA3		0
	2	DA2		0
	1	DA1		1
	0	DA0		0 (LSB device address)
Data byte	7 (MSB)	RFA	INPUT	Request for acknowledge
	6	A1		0, Register Address bit 1
	5	A0		0, Register Address bit 0
	4	D4		Data bit 4
	3	D3		Data bit 3
	2	D2		Data bit 2
	1	D1		Data bit 1
	0 (LSB)	D0		Data bit 0
		ACK	OUTPUT	Acknowledge signal is active 0, this output signal will only be delivered if RFA bit is set to 1. The signal is an open drain output; the host must have a pull-up resistor on this line for proper operation. If the master is using a push-pull output connected to this line, the acknowledge condition will not operate properly.

Data is transmitted with MSB first and LSB last. Prior to transmitting the address and data bytes, a start condition must be initiated by pulling the CTRL pin high for at least  $t_{START}$  ( $2\mu s$  min) before the bit transmission starts with the falling edge. If the CTRL pin is already high, a start condition is not needed before the device address byte. The transmission of each byte is closed with an End of Stream condition for at least  $t_{EOS}$  ( $2\mu s$ ). Internal determination of the bit value is based on the timing relationship between  $t_{LOW}$  and  $t_{HIGH}$  as follows and shown in Figure 3.

High Bit:  $t_{HIGH} \geq 2 \times t_{LOW}$

Low Bit:  $t_{LOW} \geq 2 \times t_{HIGH}$

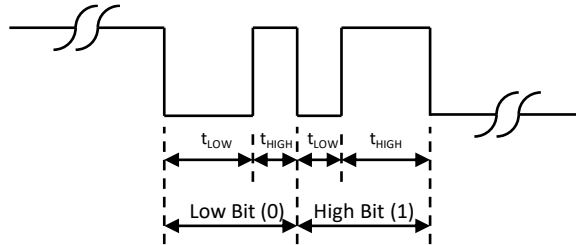

**Figure 3. ExpressWire Programming Bit Coding**

A falling edge on the CTRL pin starts the bit detection, and ends with the next falling edge. Depending on the timing of  $t_{HIGH}$  and  $t_{LOW}$ , a logic 0 or 1 is detected. The acknowledge condition is only applied if:

1. Acknowledge is requested by RFA=1.
2. The transmitted device address matches with the device address of the device.
3. The transmitted register address matches with the register address of the device.
4. 16 bits are properly received.

If the device turns on the internal Acknowledge-Output MOSFET and pulls the CTRL pin low for the time  $t_{ACK}$  ( $512\mu s$  max), then the acknowledge condition is valid after an internal delay time  $t_{ACK\_VAL}$ . This means that the internal ACKN-MOSFET is turned on after  $t_{ACK\_VAL}$ , when the last falling edge of the protocol was detected. The master's output keeps the line low during  $t_{ACK\_VAL}$ . In order for the master to detect the acknowledge condition, it will release the CTRL pin after  $t_{ACK\_VAL}$  and read back a logic 0. The CTRL pin is ready to accept inputs again after the acknowledge duration period. It is important to understand that the acknowledge condition may only be requested if the master has an open drain output. If the master is using a push-pull output stage to drive the CTRL pin, a series current limiting resistor in the CTRL line should be used to protect the Acknowledge-Output MOSFET in case of an accidental Request for Acknowledge command.

## Application Information

### Inductor Selection

A  $10\mu H$  inductor is recommended. If high efficiency is a critical requirement, a low DCR inductor should be selected. The inductor's saturation current rating should also exceed the peak input current, especially for high load current application.

**Table 3. Recommended Inductor Part Number**

Application	Inductor Part Number	Value ( $\mu H$ )	DCR ( $\Omega$ )	Saturation Current (A)	Dimensions (mm)	Manufacturer
20mA 10-series LEDs	VLCF5020T-100M1R1-1	10	0.2	1.1	$5 \times 5 \times 2.0$	TDK
20mA 10-series LEDs	VLCF5020T-220MR75-1	22	0.4	0.75	$5 \times 5 \times 2.0$	TDK

## Capacitor Selection

Small size ceramic capacitors are ideal for KTD2505R applications. A 4.7 $\mu$ F input capacitor and a 1 $\mu$ F output capacitor are suggested. A 0.22 $\mu$ F compensation capacitor connected from COMP pin to GND is suitable for most applications.

**Table 4. Recommended Ceramic Capacitor Vendors**

Manufacturer	Website
Murata	www.murata.com
AVX	www.avx.com
Taiyo Yuden	www.t-yuden.com

## Diode Selection

Using a schottky diode is recommended in KTD2505R applications because of its low forward voltage drop and fast reverse recovery time. The current rating of the schottky diode should exceed the peak current of the boost converter. The voltage rating should also exceed the OVP threshold under open-load condition.

**Table 5. Recommended Schottky Diode Part Numbers**

Application	Schottky Diode Part Number	Forward Voltage (V)	Forward Current (mA)	Reverse Voltage (V)	Manufacturer
20mA, 8/10-series LEDs, 38V OVP	B150	0.75	1000	50	Vishay www.vishay.com

## LED Maximum Current Setting

LED maximum current setting,  $I_{MAX}$ , is determined by the feedback resistor R1 (connected between FB and GND pins). The feedback voltage is internally set at 200mV at 100% dimming setting. The LED current is programmed according to the formula  $I_{MAX} = 200mV/R1$ . For accurate LED current settings, precision 1% resistors are recommended. The formula and table for R1 selection are shown below.

$$R1 = 200mV/I_{MAX}$$

**Table 5. Current Setting Resistor (1% Values)**

R1 ( $\Omega$ ) 1% Values	$I_{MAX}$ Current (mA)
200	1
40.2	5
20.0	10
13.3	15
10.0	20
6.65	30
2.00	100

## Parallel LED Configuration

KTD2505R can drive LED loads with parallel connections, as shown in Figure 4. The feedback resistor is selected to set the full-scale total current of all parallel strings combined. Figure 4 shows an example which controls total 40mA current at 100% setting, by using a 5Ω resistor.

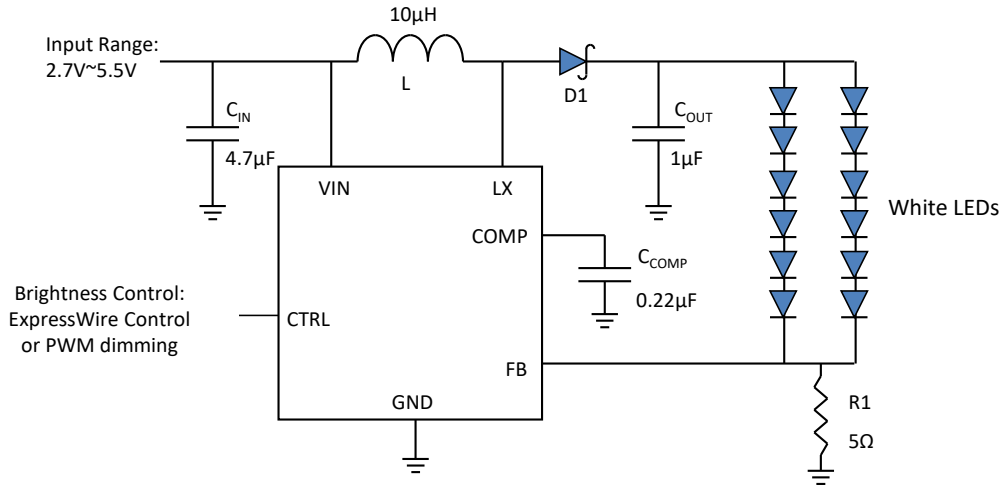

**Figure 4. Multi-string LED Application Example**

## Packaging Information

TDFN22-6

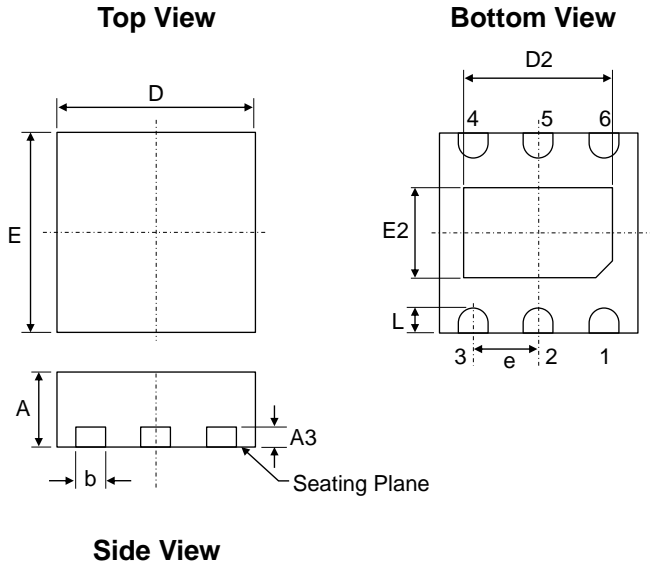

Dimension	mm		
	Min.	Typ.	Max.
A	0.70	0.75	0.80
A3	0.2BSC		
b	0.25	0.30	0.35
D	1.90	2.00	2.10
D2	1.40	1.50	1.60
E	1.90	2.00	2.10
E2	0.80	0.90	1.00
e	0.65BSC		
L	0.20	0.25	0.30

### Recommended Footprint

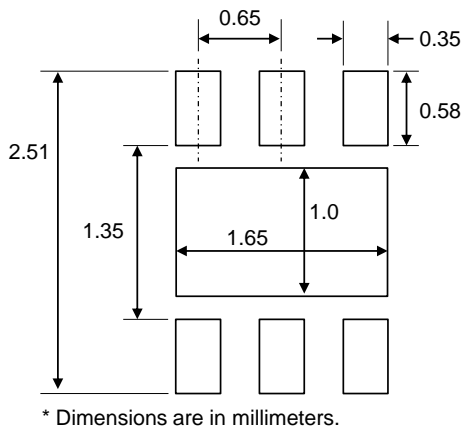

### Tape and Reel Orientation

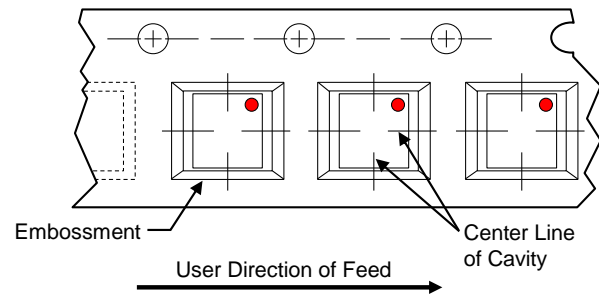

Kinetic Technologies cannot assume responsibility for use of any circuitry other than circuitry entirely embodied in a Kinetic Technologies product. No intellectual property or circuit patent licenses are implied. Kinetic Technologies reserves the right to change the circuitry and specifications without notice at any time.

## Looking for pricing, stock, or lifecycle information?

Click below to explore more details on WIN SOURCE:

 [View KTD2505RECD-TR on WIN SOURCE](#)

 [Kinetic Information](#)

## Optimize Your Supply Chain with WIN SOURCE Solutions

-  Global Sourcing Solution
-  Obsolete Management
-  Cost Control Management
-  Shortage Management
-  Alternative Solution
-  Excess Inventory Management