



## KSZ8021RNL / KSZ8031RNL

10Base-T/100Base-TX PHY  
with RMII Support

### General Description

The KSZ8031RNL is a single-supply 10Base-T/100Base-TX Ethernet physical layer transceiver for transmission and reception of data over standard CAT-5 unshielded twisted pair (UTP) cable.

The KSZ8031RNL is a highly-integrated, compact solution. It reduces board cost and simplifies board layout by using on-chip termination resistors for the differential pairs, by integrating a low noise regulator to supply the 1.2V core, and by offering 1.8/2.5/3.3V digital I/O interface support.

The KSZ8031RNL offers the Reduced Media Independent Interface (RMII) for direct connection to RMII-compliant MACs in Ethernet processors and switches.

As the power-up default, the KSZ8031RNL uses a 25MHz crystal to generate all required clocks, including the 50MHz RMII reference clock output for the MAC. The KSZ8021RNL is the version that takes in the 50MHz RMII reference clock as the power-up default.

To facilitate system bring-up and debugging in production testing and in product deployment, parametric NAND tree support enables fault detection between KSZ8031RNL I/Os and board, while Micrel's LinkMD<sup>®</sup> TDR-based cable diagnostics permit identification of faulty copper cabling.

The KSZ8031RNL and KSZ8021RNL are available in 24-pin, lead-free QFN packages (see *Ordering Information*).

Data sheets and support documentation can be found on Micrel's web site at: [www.micrel.com](http://www.micrel.com).

### Features

- Single-chip 10Base-T/100Base-TX IEEE 802.3 compliant Ethernet Transceiver
- RMII v1.2 Interface support with 50MHz reference clock output to MAC, and option to input 50MHz reference clock
- RMII back-to-back mode support for 100Mbps copper repeater or media converter
- MDC/MDIO Management Interface for PHY register configuration
- Programmable interrupt output
- LED outputs for link and activity status indication
- On-chip termination resistors for the differential pairs
- Baseline Wander Correction
- HP Auto MDI/MDI-X for reliable detection and correction for straight-through and crossover cables with disable and enable option
- Auto-negotiation to automatically select the highest link-up speed (10/100 Mbps) and duplex (half/full)
- Power down and power saving modes
- LinkMD<sup>®</sup> TDR-based cable diagnostics for identification of faulty copper cabling
- Parametric NAND Tree support for fault detection between chip I/Os and board

### Functional Diagram

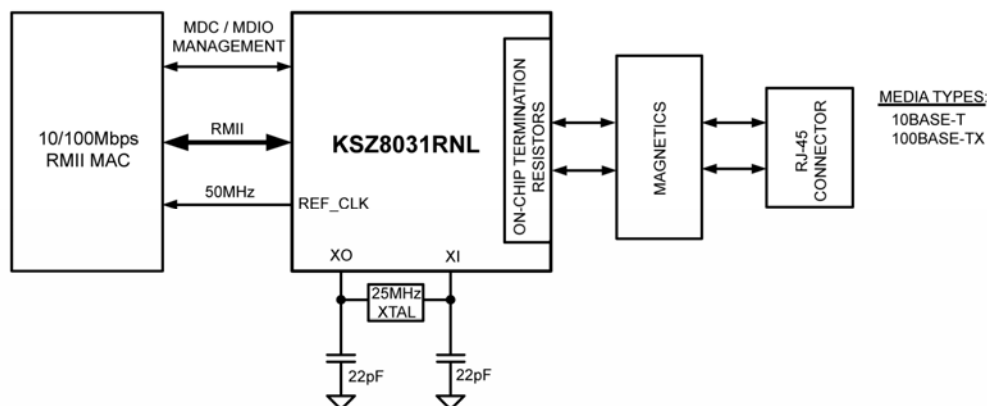

LinkMD is a registered trademark of Micrel, Inc.

Micrel Inc. • 2180 Fortune Drive • San Jose, CA 95131 • USA • tel +1 (408) 944-0800 • fax +1 (408) 474-1000 • <http://www.micrel.com>

## More Features

- Loopback modes for diagnostics
- Single 3.3V power supply with VDD I/O options for 1.8V, 2.5V, or 3.3V
- Built-in 1.2V regulator for core
- Available in 24-pin (4mm x 4mm) QFN package

## Applications

- Game Console
- IP Phone
- IP Set-top Box
- IP TV
- LOM
- Printer

## Ordering Information

Part Number	Temperature Range	Package	Lead Finish	Description
KSZ8021RNL	0°C to 70°C	24-Pin QFN	Pb-Free	RMII with 50MHz clock input (power-up default), Commercial Temperature
KSZ8021RNL <sup>(1)</sup>	-40°C to 85°C	24-Pin QFN	Pb-Free	RMII with 50MHz clock input (power-up default), Industrial Temperature
KSZ8031RNL	0°C to 70°C	24-Pin QFN	Pb-Free	RMII with 25MHz crystal/clock input and 50MHz RMII REF_CLK output (power-up default), Commercial Temperature
KSZ8031RNL <sup>(1)</sup>	-40°C to 85°C	24-Pin QFN	Pb-Free	RMII with 25MHz crystal/clock input and 50MHz RMII REF_CLK output (power-up default), Industrial Temperature

**Note:**

1. Contact factory for lead time.

**Revision History**

<b>Revision</b>	<b>Date</b>	<b>Summary of Changes</b>
1.0	8/16/10	Data sheet created.

## Contents

<b>General Description</b> .....	<b>1</b>
<b>Features</b> .....	<b>1</b>
<b>Functional Diagram</b> .....	<b>1</b>
<b>Applications</b> .....	<b>2</b>
<b>Ordering Information</b> .....	<b>2</b>
<b>Revision History</b> .....	<b>3</b>
<b>Contents</b> .....	<b>4</b>
<b>List of Figures</b> .....	<b>6</b>
<b>List of Tables</b> .....	<b>7</b>
<b>Pin Configuration – KSZ8021RNL / KSZ8031RNL</b> .....	<b>8</b>
<b>Pin Description – KSZ8021RNL / KSZ8031RNL</b> .....	<b>9</b>
<b>Strapping Options – KSZ8021RNL / KSZ8031RNL</b> .....	<b>11</b>
<b>Functional Description: 10Base-T/100Base-TX Transceiver</b> .....	<b>12</b>
100Base-TX Transmit.....	12
100Base-TX Receive.....	12
10Base-T Transmit .....	12
10Base-T Receive .....	13
Scrambler/De-scrambler (100Base-TX only).....	13
PLL Clock Synthesizer.....	13
Auto-Negotiation .....	13
<b>RMII Data Interface</b> .....	<b>15</b>
RMII Signal Definition .....	15
<i>Reference Clock (REF_CLK)</i> .....	15
<i>Transmit Enable (TXEN)</i> .....	15
<i>Transmit Data [1:0] (TXD[1:0])</i> .....	15
<i>Carrier Sense/Receive Data Valid (CRS_DV)</i> .....	15
<i>Receive Data [1:0] (RXD[1:0])</i> .....	16
<i>Receive Error (RXER)</i> .....	16
<i>Collision Detection</i> .....	16
<b>RMII Signal Diagram – for KSZ8021/31RNL</b> .....	<b>16</b>
RMII – 25MHz Clock Mode.....	16
RMII – 50MHz Clock Mode.....	17
<b>Back-to-Back Mode – 100Mbps Copper Repeater / Media Converter</b> .....	<b>18</b>
RMII Back-to-Back Mode.....	18
<b>MII Management (MIIM) Interface</b> .....	<b>19</b>
<b>Interrupt (INTRP)</b> .....	<b>19</b>
<b>HP Auto MDI/MDI-X</b> .....	<b>19</b>
Straight Cable .....	20
Crossover Cable .....	20
<b>LinkMD<sup>®</sup> Cable Diagnostics</b> .....	<b>21</b>

<b>NAND Tree Support</b> .....	<b>21</b>
NAND Tree I/O Testing.....	22
<b>Power Management</b> .....	<b>22</b>
Power Saving Mode.....	22
Energy Detect Power Down Mode .....	22
Power Down Mode .....	22
Slow Oscillator Mode.....	23
<b>Reference Circuit for Power and Ground Connections</b> .....	<b>23</b>
<b>Register Map</b> .....	<b>24</b>
<b>Register Description</b> .....	<b>24</b>
<b>Register Description (Continued)</b> .....	<b>25</b>
<b>Register Description (Continued)</b> .....	<b>26</b>
<b>Register Description (Continued)</b> .....	<b>27</b>
<b>Register Description (Continued)</b> .....	<b>28</b>
<b>Register Description (Continued)</b> .....	<b>29</b>
<b>Register Description (Continued)</b> .....	<b>30</b>
<b>Register Description (Continued)</b> .....	<b>31</b>
<b>Register Description (Continued)</b> .....	<b>32</b>
<b>Absolute Maximum Ratings<sup>(1)</sup></b> .....	<b>33</b>
<b>Operating Ratings<sup>(2)</sup></b> .....	<b>33</b>
<b>Electrical Characteristics<sup>(3)</sup></b> .....	<b>33</b>
<b>Electrical Characteristics<sup>(3)</sup> (Continued)</b> .....	<b>34</b>
<b>Timing Diagrams</b> .....	<b>35</b>
RMII Timing.....	35
Auto-Negotiation Timing .....	36
MDC/MDIO Timing .....	37
Reset Timing.....	38
<b>Reset Circuit</b> .....	<b>39</b>
<b>Reference Circuit for LED Strapping Pin</b> .....	<b>40</b>
<b>Magnetics Specification</b> .....	<b>41</b>
<b>Reference Clock – Connection and Selection</b> .....	<b>41</b>
<b>Package Information</b> .....	<b>43</b>

## List of Figures

Figure 1. Auto-Negotiation Flow Chart.....	14
Figure 2. KSZ8021/31RNL RMII Interface (RMII – 25MHz Clock Mode) .....	16
Figure 3. KSZ8021/31RNL RMII Interface (RMII – 50MHz Clock Mode) .....	17
Figure 4. KSZ8021/31RNL and KSZ8041FTL RMII Back-to-Back Media Converter .....	18
Figure 5. Typical Straight Cable Connection .....	20
Figure 6. Typical Crossover Cable Connection .....	20
Figure 7. KSZ8021/31RNL Power and Ground Connections .....	23
Figure 8. RMII Timing – Data Received from RMII .....	35
Figure 9. RMII Timing – Data Input to RMII .....	35
Figure 10. Auto-Negotiation Fast Link Pulse (FLP) Timing .....	36
Figure 11. MDC/MDIO Timing.....	37
Figure 12. Reset Timing.....	38
Figure 13. Recommended Reset Circuit.....	39
Figure 14. Recommended Reset Circuit for interfacing with CPU/FPGA Reset Output.....	39
Figure 15. Reference Circuits for LED Strapping Pin .....	40
Figure 16. 25MHz Crystal / Oscillator Reference Clock Connection .....	41
Figure 17. 50MHz Oscillator Reference Clock Connection .....	42

## List of Tables

Table 1. RMII Signal Description.....	15
Table 2. RMII Signal Connection for RMII Back-to-Back Mode (100Base-TX Copper Repeater) .....	18
Table 3. MII Management Frame Format – for KSZ8021/31RNL.....	19
Table 4. MDI/MDI-X Pin Definition .....	20
Table 5. NAND Tree Test Pin Order – for KSZ8021/31RNL .....	21
Table 6. KSZ8021/31RNL Power Pin Description .....	23
Table 7. RMII Timing Parameters – KSZ8021/31RNL (25MHz input to XI pin, 50MHz output from REF_CLK pin).....	35
Table 8. RMII Timing Parameters – KSZ8021/31RNL (50MHz input to XI pin).....	35
Table 9. Auto-Negotiation Fast Link Pulse (FLP) Timing Parameters.....	36
Table 10. MDC/MDIO Timing Parameters .....	37
Table 11. Reset Timing Parameters .....	38
Table 12. Magnetics Selection Criteria .....	41
Table 13. Qualified Single Port 10/100 Magnetics.....	41
Table 14. 25MHz Crystal / Reference Clock Selection Criteria .....	42
Table 15. 50MHz Oscillator / Reference Clock Selection Criteria .....	42

### Pin Configuration – KSZ8021RNL / KSZ8031RNL

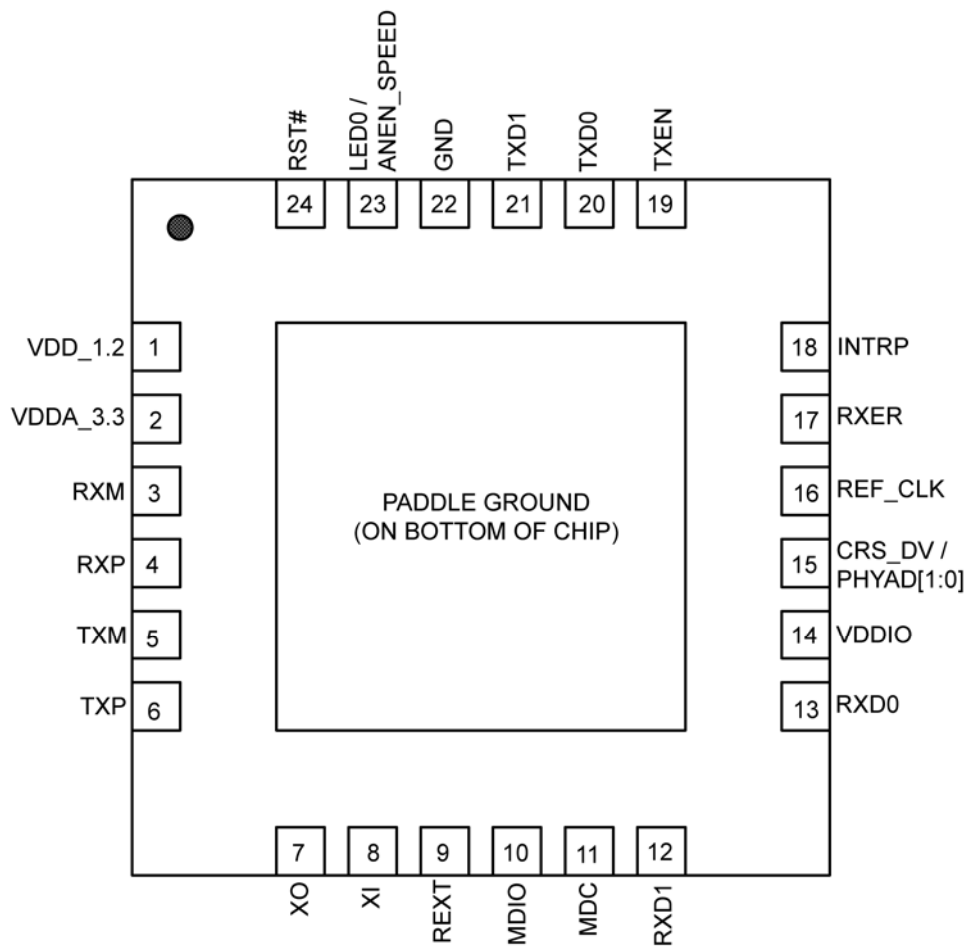

**24-Pin (4mm x 4mm) QFN**

**Pin Description – KSZ8021RNL / KSZ8031RNL**

Pin Number	Pin Name	Type <sup>(1)</sup>	Pin Function
1	VDD_1.2	P	1.2V core V <sub>DD</sub> (power supplied by KSZ8021RNL / KSZ8031RNL) Decouple with 2.2uF and 0.1uF capacitors-to-ground.
2	VDDA_3.3	P	3.3V analog V <sub>DD</sub> .
3	RXM	I/O	Physical receive or transmit signal (- differential)
4	RXP	I/O	Physical receive or transmit signal (+ differential)
5	TXM	I/O	Physical transmit or receive signal (- differential)
6	TXP	I/O	Physical transmit or receive signal (+ differential)
7	XO	O	Crystal feedback – for 25 MHz crystal This pin is a no connect if oscillator or external clock source is used.
8	XI	I	RMII – 25MHz Mode: 25MHz +/-50ppm Crystal / Oscillator / External Clock Input RMII – 50MHz Mode: 50MHz +/-50ppm Oscillator / External Clock Input For unmanaged mode (power-up default setting), KSZ8021RNL takes in the 50MHz clock on this pin. KSZ8031RNL takes in the 25MHz crystal / clock on this pin. After power-up, both the KSZ8021RNL and KSZ8031RNL can be programmed via PHY register 1Fh bit [7] to either the 25MHz mode or 50MHz mode. See also REF_CLK (pin 16) description.
9	REXT	I	Set physical transmit output current Connect a 6.49KΩ resistor-to-ground on this pin.
10	MDIO	I/O	Management Interface (MII) Data I/O This pin has a weak pull-up, is open drain like, and requires an external 1.0KΩ pull-up resistor.
11	MDC	I	Management Interface (MII) Clock Input This clock pin is synchronous to the MDIO data pin.
12	RXD1	Ipd/O	RMII Receive Data Output[1] <sup>(2)</sup>
13	RXD0	Ipu/O	RMII Receive Data Output[0] <sup>(2)</sup>
14	VDDIO	P	3.3V, 2.5V or 1.8V digital V <sub>DD</sub>
15	CRS_DV / PHYAD[1:0]	Ipd/O	RMII Mode: Carrier Sense/Receive Data Valid Output / Config Mode: The pull-up/pull-down value is latched as PHYAD[1:0] at the de-assertion of reset. See “Strapping Options” section for details.
16	REF_CLK	Ipd/O	RMII – 25MHz Mode: This pin provides the 50MHz RMII reference clock output to the MAC. RMII – 50MHz Mode: This pin is a no connect. For unmanaged mode (power-up default setting), KSZ8021RNL is in RMII – 50MHz mode and does not use this pin. KSZ8031RNL is in RMII – 25MHz mode and outputs the 50MHz RMII reference clock on this pin. After power-up, both KSZ8021RNL and KSZ8031RNL can be programmed via PHY register 1Fh bit [7] to either 25MHz mode or 50MHz mode. See also XI (pin 8) description.
17	RXER	Ipd/O	RMII Receive Error Output
18	INTRP	Ipu/Opu	Interrupt Output: Programmable Interrupt Output This pin has a weak pull-up, is open drain like, and requires an external 1.0KΩ pull-up resistor.

**Pin Description – KSZ8021RNL / KSZ8031RNL (Continued)**

Pin Number	Pin Name	Type <sup>(1)</sup>	Pin Function																											
19	TXEN	I	RMII Transmit Enable Input																											
20	TXD0	I	RMII Transmit Data Input[0] <sup>(3)</sup>																											
21	TXD1	I/O	RMII Transmit Data Input[1] <sup>(3)</sup> NAND Tree Mode: NAND Tree output pin																											
22	GND	Gnd	Ground																											
23	LED0 / ANEN_SPEED	Ipu/O	<p>LED Output: Programmable LED0 Output / Config Mode: Latched as Auto-Negotiation Enable (register 0h, bit [12]) and SPEED (register 0h, bit [13]) at the de-assertion of reset. See “Strapping Options” section for details. The LED0 pin is programmable via register 1Fh bits [5:4], and is defined as follows.</p> <table border="1"> <thead> <tr> <th colspan="3">LED mode = [00]</th> </tr> <tr> <th>Link/Activity</th> <th>Pin State</th> <th>LED Definition</th> </tr> </thead> <tbody> <tr> <td>No Link</td> <td>High</td> <td>OFF</td> </tr> <tr> <td>Link</td> <td>Low</td> <td>ON</td> </tr> <tr> <td>Activity</td> <td>Toggle</td> <td>Blinking</td> </tr> </tbody> </table> <table border="1"> <thead> <tr> <th colspan="3">LED mode = [01]</th> </tr> <tr> <th>Link</th> <th>Pin State</th> <th>LED Definition</th> </tr> </thead> <tbody> <tr> <td>No Link</td> <td>High</td> <td>OFF</td> </tr> <tr> <td>Link</td> <td>Low</td> <td>ON</td> </tr> </tbody> </table> <p>LED mode = [10], [11] Reserved</p>	LED mode = [00]			Link/Activity	Pin State	LED Definition	No Link	High	OFF	Link	Low	ON	Activity	Toggle	Blinking	LED mode = [01]			Link	Pin State	LED Definition	No Link	High	OFF	Link	Low	ON
LED mode = [00]																														
Link/Activity	Pin State	LED Definition																												
No Link	High	OFF																												
Link	Low	ON																												
Activity	Toggle	Blinking																												
LED mode = [01]																														
Link	Pin State	LED Definition																												
No Link	High	OFF																												
Link	Low	ON																												
24	RST#	I	Chip Reset (active low)																											
PADDLE	GND	Gnd	Ground																											

**Notes:**

- P = Power supply.  
Gnd = Ground.  
I = Input.  
O = Output.  
I/O = Bi-directional.  
Ipu/O = Input with internal pull-up (see Electrical Characteristics for value) during power-up/reset; output pin otherwise.  
Ipd/O = Input with internal pull-down (see Electrical Characteristics for value) during power-up/reset; output pin otherwise.  
Ipu/Opu = Input with internal pull-up (see Electrical Characteristics for value) during power-up/reset; output pin with internal pull-up (see Electrical Characteristics for value) otherwise.
- RMII Rx Mode: The RXD[1:0] bits are synchronous with the 50MHz RMII Reference Clock. For each clock period in which CRS\_DV is asserted, two bits of recovered data are sent by the PHY to the MAC.
- RMII Tx Mode: The TXD[1:0] bits are synchronous with the 50MHz RMII Reference Clock. For each clock period in which TXEN is asserted, two bits of data are received by the PHY from the MAC.

## Strapping Options – KSZ8021RNL / KSZ8031RNL

Pin Number	Pin Name	Type <sup>(1)</sup>	Pin Function
15	PHYAD[1:0]	lpd/O	<p>The PHY Address is latched at the de-assertion of reset and is configurable to either one of the following two values:</p> <p>Pull-up = PHY Address is set to 00011b (0x3h)</p> <p>Pull-down (default) = PHY Address is set to 00000b (0x0h)</p> <p>PHY Address bits [4:2] are set to '000' by default.</p>
23	ANEN_SPEED	lpu/O	<p>Auto-Negotiation Enable and SPEED mode</p> <p>Pull-up (default) = Enable Auto-Negotiation and set 100Mbps Speed</p> <p>Pull-down = Disable Auto-Negotiation and set 10Mbps Speed</p> <p>At the de-assertion of reset, this pin value is latched into register 0h bit [12] for Auto-negotiation enable/disable, register 0h bit [13] for the Speed select, and register 4h (Auto-Negotiation Advertisement) for the Speed capability support.</p>

**Note:**

1. lpu/O = Input with internal pull-up (see Electrical Characteristics for value) during power-up/reset; output pin otherwise.  
lpd/O = Input with internal pull-down (see Electrical Characteristics for value) during power-up/reset; output pin otherwise.

The PHYAD[1:0] strap-in pin is latched at the de-assertion of reset. In some systems, the RMII MAC receive input pin may drive high/low during power-up or reset, and consequently cause the PHYAD[1:0] strap-in pin, a shared pin with the RMII CRS\_DV signal, to be latched to the unintended high/low states. In this case, an external pull-up (4.7K) or pull-down (1.0K) should be added on the PHYAD[1:0] strap-in pin to ensure the intended value is strapped-in correctly.

## Functional Description: 10Base-T/100Base-TX Transceiver

The KSZ8031RNL is an integrated single 3.3V supply Fast Ethernet transceiver. It is fully compliant with the IEEE 802.3 Specification. It reduces board cost and simplifies board layout by using on-chip termination resistors for the two differential pairs and by integrating the regulator to supply the 1.2V core.

On the copper media side, the KSZ8031RNL supports 10Base-T and 100Base-TX for transmission and reception of data over a standard CAT-5 unshielded twisted pair (UTP) cable, and HP auto MDI/MDI-X for reliable detection of and correction for straight-through and crossover cables.

On the MAC side, the KSZ8031RNL provides the Reduced Media Independent Interface (RMII) for direct connection with RMII-compliant Ethernet MAC processors and switches.

The MII management bus option gives the MAC processor complete access to the KSZ8031RNL control and status registers. Additionally, an interrupt pin eliminates the need for the processor to poll for PHY status change.

As the power-up default, the KSZ8031RNL uses a 25MHz crystal to generate all required clocks, including the 50MHz RMII reference clock output for the MAC. The KSZ8021RNL is the version which takes in the 50MHz RMII reference clock as the power-up default.

The KSZ8021/31RNL is used to refer to both KSZ8021RNL and KSZ8031RNL versions in this data sheet.

### 100Base-TX Transmit

The 100Base-TX transmit function performs parallel-to-serial conversion, 4B/5B encoding, scrambling, NRZ-to-NRZI conversion, and MLT3 encoding and transmission.

The circuitry starts with a parallel-to-serial conversion, which converts the MII data from the MAC into a 125MHz serial bit stream. The data and control stream is then converted into 4B/5B coding and followed by a scrambler. The serialized data is further converted from NRZ-to-NRZI format, and then transmitted in MLT3 current output. The output current is set by an external 6.49k $\Omega$  1% resistor for the 1:1 transformer ratio.

The output signal has a typical rise/fall time of 4ns and complies with the ANSI TP-PMD standard regarding amplitude balance, overshoot, and timing jitter. The wave-shaped 10Base-T output is also incorporated into the 100Base-TX transmitter.

### 100Base-TX Receive

The 100Base-TX receiver function performs adaptive equalization, DC restoration, MLT3-to-NRZI conversion, data and clock recovery, NRZI-to-NRZ conversion, de-scrambling, 4B/5B decoding, and serial-to-parallel conversion.

The receiving side starts with the equalization filter to compensate for inter-symbol interference (ISI) over the twisted pair cable. Since the amplitude loss and phase distortion is a function of the cable length, the equalizer must adjust its characteristics to optimize performance. In this design, the variable equalizer makes an initial estimation based upon comparisons of incoming signal strength against some known cable characteristics, and then tunes itself for optimization. This is an ongoing process and self-adjusts against environmental changes such as temperature variations.

Next, the equalized signal goes through a DC restoration and data conversion block. The DC restoration circuit is used to compensate for the effect of baseline wander and to improve the dynamic range. The differential data conversion circuit converts the MLT3 format back to NRZI. The slicing threshold is also adaptive.

The clock recovery circuit extracts the 125MHz clock from the edges of the NRZI signal. This recovered clock is then used to convert the NRZI signal into the NRZ format. This signal is sent through the de-scrambler followed by the 4B/5B decoder. Finally, the NRZ serial data is converted to the MII format and provided as the input data to the MAC.

### 10Base-T Transmit

The 10Base-T drivers are incorporated with the 100Base-TX drivers to allow for transmission using the same magnetic. The drivers perform internal wave-shaping and pre-emphasis, and output 10Base-T signals with a typical amplitude of 2.5V peak. The 10Base-T signals have harmonic contents that are at least 27dB below the fundamental frequency when driven by an all-ones Manchester-encoded signal.

### 10Base-T Receive

On the receive side, input buffer and level detecting squelch circuits are employed. A differential input receiver circuit and a PLL performs the decoding function. The Manchester-encoded data stream is separated into clock signal and NRZ data. A squelch circuit rejects signals with levels less than 400 mV or with short pulse widths to prevent noise at the RXP and RXM inputs from falsely triggering the decoder. When the input exceeds the squelch limit, the PLL locks onto the incoming signal and the KSZ8021/31RNL decodes a data frame. The receive clock is kept active during idle periods in between data reception.

### Scrambler/De-Scrambler (100Base-TX Only)

The scrambler is used to spread the power spectrum of the transmitted signal to reduce EMI and baseline wander, and the de-scrambler is needed to recover the scrambled signal.

### PLL Clock Synthesizer

The KSZ8021/31RNL in RMII – 25MHz Clock Mode generates all internal clocks and all external clocks for system timing from an external 25MHz crystal, oscillator, or reference clock. For the KSZ8021/31RNL in RMII – 50MHz Clock Mode, these clocks are generated from an external 50MHz oscillator or system clock.

### Auto-Negotiation

The KSZ8021/31RNL conforms to the auto-negotiation protocol, defined in Clause 28 of the IEEE 802.3 Specification.

Auto-negotiation allows UTP (Unshielded Twisted Pair) link partners to select the highest common mode of operation.

During auto-negotiation, link partners advertise capabilities across the UTP link to each other, and then compare their own capabilities with those they received from their link partners. The highest speed and duplex setting that is common to the two link partners is selected as the mode of operation.

The following list shows the speed and duplex operation mode from highest to lowest priority.

- Priority 1: 100Base-TX, full-duplex
- Priority 2: 100Base-TX, half-duplex
- Priority 3: 10Base-T, full-duplex
- Priority 4: 10Base-T, half-duplex

If auto-negotiation is not supported or the KSZ8021/31RNL link partner is forced to bypass auto-negotiation, then the KSZ8021/31RNL sets its operating mode by observing the signal at its receiver. This is known as parallel detection, and allows the KSZ8021/31RNL to establish link by listening for a fixed signal protocol in the absence of auto-negotiation advertisement protocol.

Auto-negotiation is enabled by either hardware pin strapping (ANEN\_SPEED, pin 23) or software (register 0h, bit [12]).

By default, auto-negotiation is enabled after power-up or hardware reset. Afterwards, auto-negotiation can be enabled or disabled by register 0h, bit [12]. If auto-negotiation is disabled, the speed is set by register 0h, bit [13], and the duplex is set by register 0h, bit [8].

The auto-negotiation link up process is shown in Figure 1.

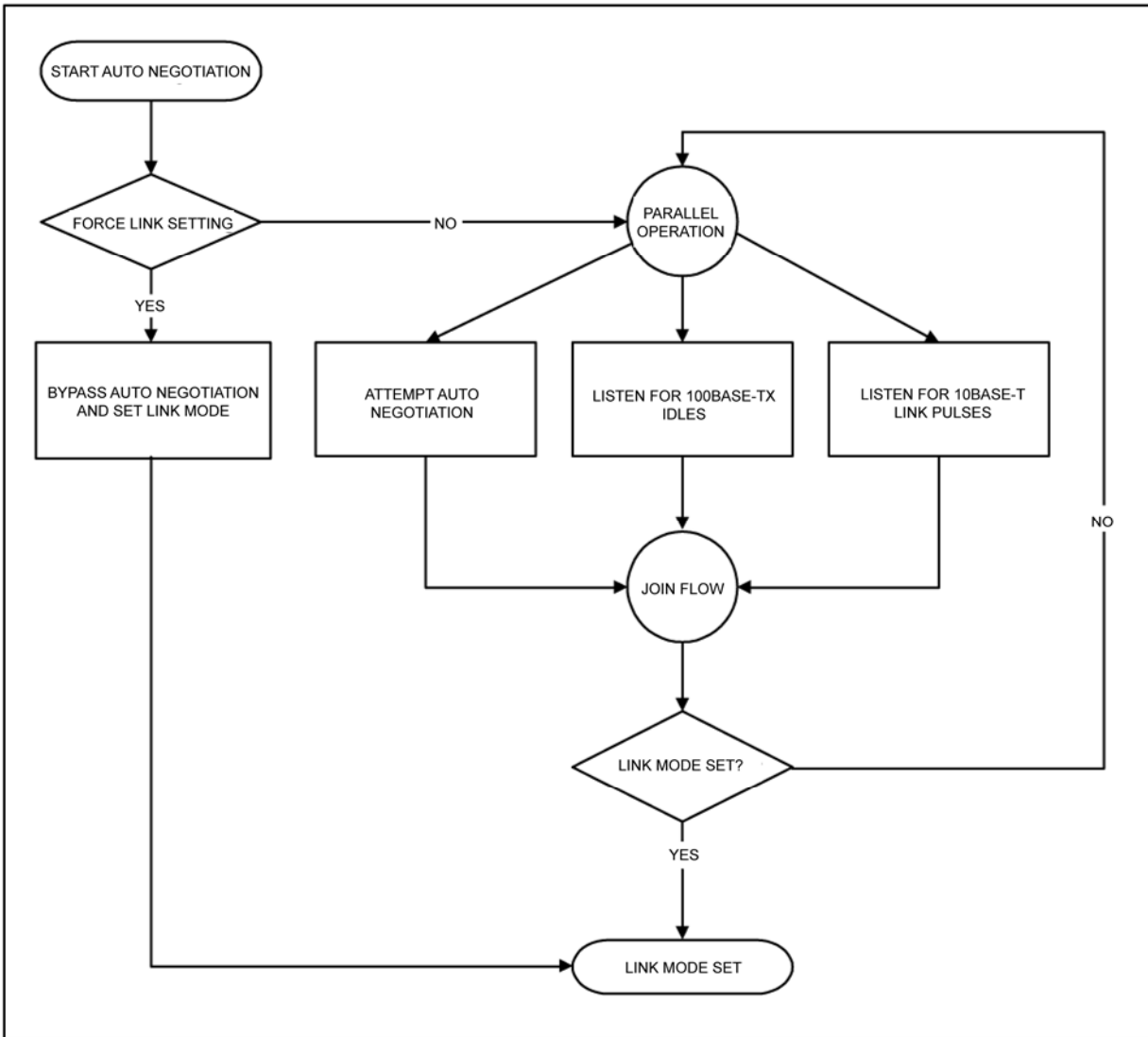

Figure 1. Auto-Negotiation Flow Chart

## RMII Data Interface

The Reduced Media Independent Interface (RMII) specifies a low pin count Media Independent Interface (MII). It provides a common interface between physical layer and MAC layer devices, and has the following key characteristics:

- Pin count is 8 pins (3 pins for data transmission, 4 pins for data reception, 1 pin for the 50MHz reference clock).
- 10Mbps and 100Mbps data rates are supported at both half and full duplex.
- Data transmission and reception are independent and belong to separate signal groups.
- Transmit data and receive data are each 2-bit wide, a dibit.

### RMII Signal Definition

The following table describes the RMII signals. Refer to RMII Specification v1.2 for detailed information.

RMII Signal Name	Direction (with respect to PHY, KSZ8021/31RNL signal)	Direction (with respect to MAC)	Description
REF_CLK	Output (25MHz Clock Mode) / <no connect> (50MHz Clock Mode)	Input / Input or <no connect>	Synchronous 50MHz reference clock for receive, transmit and control interface
TXEN	Input	Output	Transmit Enable
TXD[1:0]	Input	Output	Transmit Data [1:0]
CRS_DV	Output	Input	Carrier Sense/Receive Data Valid
RXD[1:0]	Output	Input	Receive Data [1:0]
RXER	Output	Input, or (not required)	Receive Error

**Table 1. RMII Signal Description**

#### **Reference Clock (REF\_CLK)**

REF\_CLK is a continuous 50MHz clock that provides the timing reference for TXEN, TXD[1:0], CRS\_DV, RXD[1:0], and RXER.

For RMII – 25MHz Clock Mode, the KSZ8021/31RNL generates and outputs the 50MHz RMII REF\_CLK to the MAC at REF\_CLK (Pin 16).

For RMII – 50MHz Clock Mode, the KSZ8021/31RNL takes in the 50MHz RMII REF\_CLK from the MAC or system board at XI (Pin 8) and has the REF\_CLK (pin 16) left as a no connect.

#### **Transmit Enable (TXEN)**

TXEN indicates that the MAC is presenting dibits on TXD[1:0] for transmission. It is asserted synchronously with the first dibit of the preamble and remains asserted while all dibits to be transmitted are presented on the RMII, and is negated prior to the first REF\_CLK following the final dibit of a frame.

TXEN transitions synchronously with respect to REF\_CLK.

#### **Transmit Data [1:0] (TXD[1:0])**

TXD[1:0] transitions synchronously with respect to REF\_CLK. When TXEN is asserted, TXD[1:0] are accepted for transmission by the PHY.

TXD[1:0] is "00" to indicate idle when TXEN is de-asserted. Values other than "00" on TXD[1:0] while TXEN is de-asserted are ignored by the PHY.

#### **Carrier Sense/Receive Data Valid (CRS\_DV)**

CRS\_DV is asserted by the PHY when the receive medium is non-idle. It is asserted asynchronously on detection of carrier. This is when squelch is passed in 10Mbps mode, and when two non-contiguous zeroes in 10 bits are detected in 100Mbps mode. Loss of carrier results in the de-assertion of CRS\_DV.

So long as carrier detection criteria are met, CRS\_DV remains asserted continuously from the first recovered dibit of the frame through the final recovered dibit, and it is negated prior to the first REF\_CLK that follows the final dibit. The data on RXD[1:0] is considered valid once CRS\_DV is asserted. However, since the assertion of CRS\_DV is asynchronous relative to REF\_CLK, the data on RXD[1:0] is "00" until proper receive signal decoding takes place.

**Receive Data [1:0] (RXD[1:0])**

RXD[1:0] transitions synchronously with respect to REF\_CLK. For each clock period in which CRS\_DV is asserted, RXD[1:0] transfers two bits of recovered data from the PHY.

RXD[1:0] is "00" to indicate idle when CRS\_DV is de-asserted. Values other than "00" on RXD[1:0] while CRS\_DV is de-asserted are ignored by the MAC.

**Receive Error (RXER)**

RXER is asserted for one or more REF\_CLK periods to indicate that a Symbol Error (e.g., a coding error that a PHY is capable of detecting, and that may otherwise be undetectable by the MAC sub-layer) was detected somewhere in the frame presently being transferred from the PHY.

RXER transitions synchronously with respect to REF\_CLK. While CRS\_DV is de-asserted, RXER has no effect on the MAC.

**Collision Detection**

The MAC regenerates the COL signal of the MII from TXEN and CRS\_DV.

**RMII Signal Diagram – for KSZ8021/31RNL**

The KSZ8021/31RNL RMII pin connections to the MAC are shown in the following figures for RMII – 25MHz Clock Mode and RMII – 50MHz Clock Mode.

**RMII – 25MHz Clock Mode**

The KSZ8031RNL is configured to RMII – 25MHz Clock Mode after it is powered up or hardware reset with the following:

- A 25MHz crystal connected to XI, XO (Pins 8, 7), or an external 25MHz clock source (oscillator) connected to XI

The KSZ8021RNL is configured optionally to RMII – 25MHz Clock Mode after it is powered up or hardware reset and software programmed with the following:

- A 25MHz crystal connected to XI, XO (pins 8, 7), or an external 25MHz clock source (oscillator) connected to XI
- Register 1Fh, bit [7] programmed to '0' to select RMII – 25MHz Clock Mode

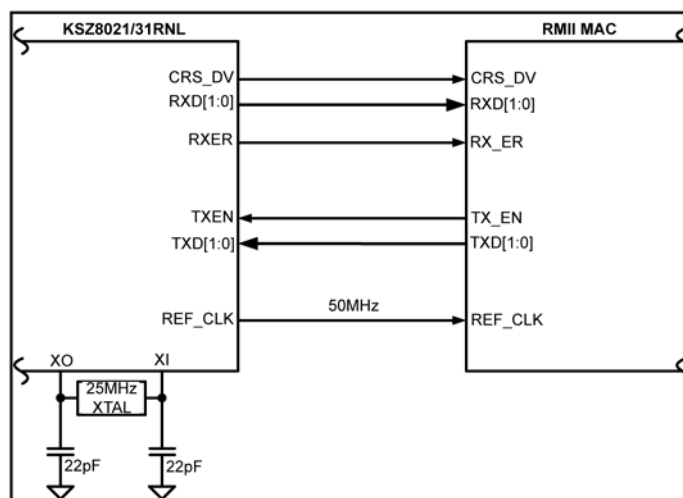

Figure 2. KSZ8021/31RNL RMII Interface (RMII – 25MHz Clock Mode)

**RMII – 50MHz Clock Mode**

The KSZ8021RNL is configured to RMII – 50MHz Clock Mode after it is powered up or hardware reset with the following:

- An external 50MHz clock source (oscillator) connected to XI (Pin 8)

The KSZ8031RNL is configured optionally to RMII – 50MHz Clock Mode after it is powered up or hardware reset and software programmed with the following:

- An external 50MHz clock source (oscillator) connected to XI (Pin 8)
- Register 1Fh, bit [7] programmed to '1' to select RMII – 50MHz Clock Mode

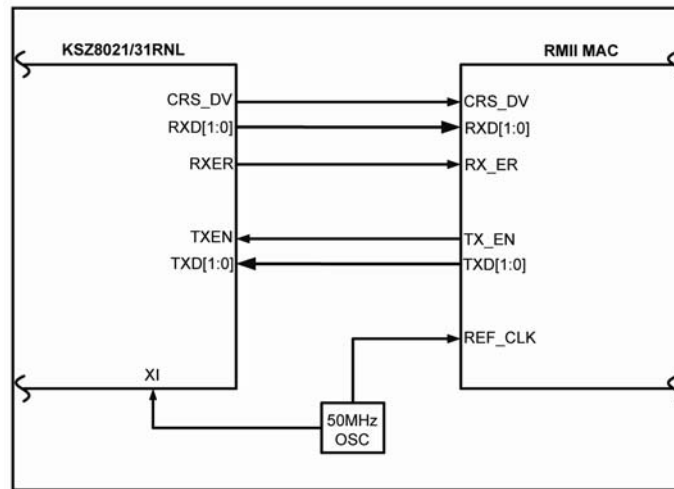

Figure 3. KSZ8021/31RNL RMII Interface (RMII – 50MHz Clock Mode)

## Back-to-Back Mode – 100Mbps Copper Repeater / Media Converter

Two KSZ8021/31RNL devices can be connected back-to-back to form a managed 100Base-TX copper repeater.

A KSZ8021/31RNL and a KSZ8041FTL can be connected back-to-back to provide a managed media converter solution. Media conversion is between 100Base-TX copper and 100Base-FX fiber. On the copper side, link up at 10Base-T is not allowed, and is blocked during auto-negotiation.

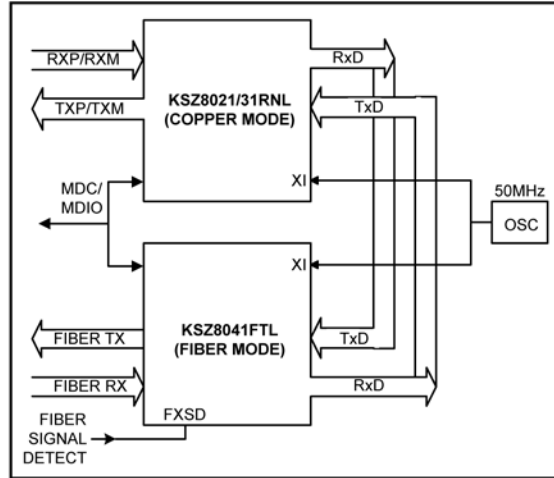

Figure 4. KSZ8021/31RNL and KSZ8041FTL RMII Back-to-Back Media Converter

### RMII Back-to-Back Mode

In RMII Back-to-Back mode, a KSZ8021/31RNL interfaces with another KSZ8021/31RNL, or a KSZ8041FTL to provide a 100Mbps copper repeater, or media converter solution, respectively.

The KSZ8021/31RNL devices are configured to RMII Back-to-Back mode after they are powered up or hardware reset and software programmed with the following:

- A common 50MHz reference clock connected to XI (Pin 8)
- Register 1Fh, bit [7] programmed to '1' to select RMII – 50MHz Clock Mode for KSZ8031RNL (KSZ8021RNL is set to RMII – 50MHz Clock Mode as the default after power up or hardware reset)
- Register 16h, bits [6] and [1] programmed to '1' and '1', respectively, to enable RMII Back-to-Back mode.
- RMII signals connected as shown in the following table.

KSZ8021/31RNL (100Base-TX copper) [Device 1]			KSZ8021/31RNL (100Base-TX copper) [Device 2]		
Pin Name	Pin Number	Pin Type	Pin Name	Pin Number	Pin Type
CRS_DV	15	Output	TXEN	19	Input
RXD1	12	Output	TXD1	21	Input
RXD0	13	Output	TXD0	20	Input
TXEN	19	Input	CRS_DV	15	Output
TXD1	21	Input	RXD1	12	Output
TXD0	20	Input	RXD0	13	Output

Table 2. RMII Signal Connection for RMII Back-to-Back Mode (100Base-TX Copper Repeater)

## MII Management (MIIM) Interface

The KSZ8021/31RNL supports the IEEE 802.3 MII Management Interface, also known as the Management Data Input / Output (MDIO) Interface. This interface enables upper-layer device, like a MAC processor, to monitor and control the state of the KSZ8021/31RNL. An external device with MIIM capability is used to read the PHY status and/or configure the PHY settings. Further details on the MIIM interface can be found in Clause 22.2.4 of the IEEE 802.3 Specification.

The MIIM interface consists of the following:

- A physical connection that incorporates the clock line (MDC) and the data line (MDIO).
- A specific protocol that operates across the aforementioned physical connection that allows the external controller to communicate with one or more PHY devices.
- A set of 16-bit MDIO registers. Registers [0:8] are standard registers, and their functions are defined per the IEEE 802.3 Specification. The additional registers are provided for expanded functionality. See “Register Map” section for details.

The KSZ8021/31RNL supports only two unique PHY addresses, 0x0h and 0x3h. The PHYAD[1:0] strapping pin is used to select either 0x0h or 0x3h as the unique PHY address for the KSZ8021/31RNL device.

Table 3 shows the MII Management frame format for the KSZ8021/31RNL.

	Preamble	Start of Frame	Read/Write OP Code	PHY Address Bits [4:0]	REG Address Bits [4:0]	TA	Data Bits [15:0]	Idle
<b>Read</b>	32 1's	01	10	000AA	RRRRR	Z0	DDDDDDDD_DDDDDDDD	Z
<b>Write</b>	32 1's	01	01	000AA	RRRRR	10	DDDDDDDD_DDDDDDDD	Z

**Table 3. MII Management Frame Format – for KSZ8021/31RNL**

## Interrupt (INTRP)

The INTRP (pin 18) is an optional interrupt signal that is used to inform the external controller that there has been a status update to the KSZ8021/31RNL PHY register. Register 1Bh, bits [15:8] are the interrupt control bits to enable and disable the conditions for asserting the INTRP signal. Register 1Bh, bits [7:0] are the interrupt status bits to indicate which interrupt conditions have occurred. The interrupt status bits are cleared after reading register 1Bh.

Register 1Fh, bit 9 sets the interrupt level to active high or active low. The default is active low.

The MII management bus option gives the MAC processor complete access to the KSZ8021/31RNL control and status registers. Additionally, an interrupt pin eliminates the need for the processor to poll the PHY for status change.

## HP Auto MDI/MDI-X

The HP Auto MDI/MDI-X configuration eliminates the confusion of whether to use a straight cable or a crossover cable between the KSZ8021/31RNL and its link partner. This feature allows the KSZ8021/31RNL to use either type of cable to connect with a link partner that is in either MDI or MDI-X mode. The auto-sense function detects transmit and receive pairs from the link partner, and then assigns transmit and receive pairs of the KSZ8021/31RNL accordingly.

HP Auto MDI/MDI-X is enabled by default. It is disabled by writing a one to register 1Fh, bit [13]. MDI and MDI-X mode is selected by register 1Fh, bit [14] if HP Auto MDI/MDI-X is disabled.

An isolation transformer with symmetrical transmit and receive data paths is recommended to support auto MDI/MDI-X.

The IEEE 802.3 Standard defines MDI and MDI-X in Table 4.

MDI		MDI-X	
RJ-45 Pin	Signal	RJ-45 Pin	Signal
1	TX+	1	RX+
2	TX-	2	RX-
3	RX+	3	TX+
6	RX-	6	TX-

**Table 4. MDI/MDI-X Pin Definition**

**Straight Cable**

A straight cable connects a MDI device to a MDI-X device, or a MDI-X device to a MDI device. Figure 5 depicts a typical straight cable connection between a NIC card (MDI) and a switch, or hub (MDI-X).

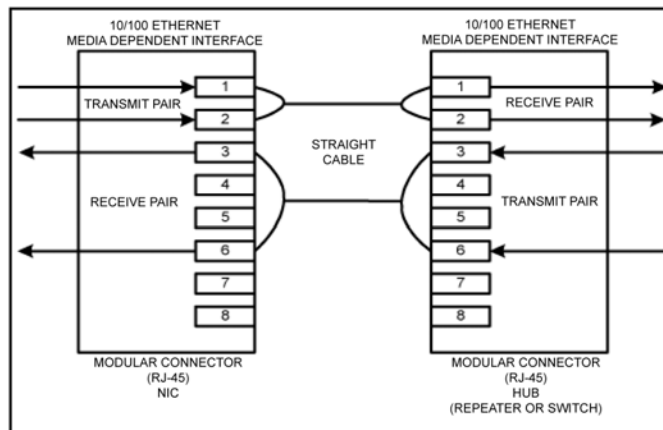

**Figure 5. Typical Straight Cable Connection**

**Crossover Cable**

A crossover cable connects a MDI device to another MDI device, or a MDI-X device to another MDI-X device. Figure 6 depicts a typical crossover cable connection between two switches or hubs (two MDI-X devices).

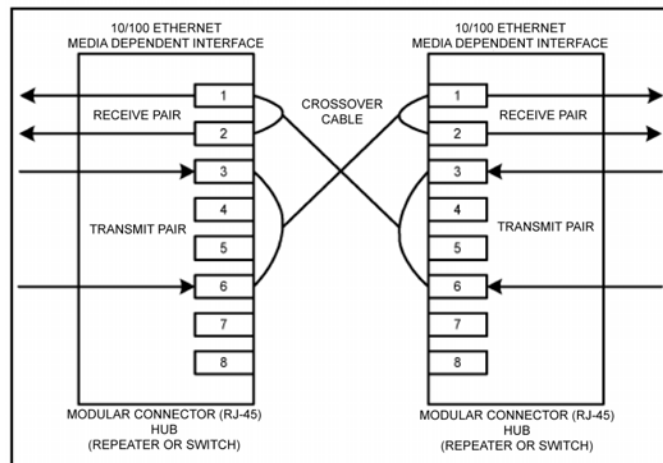

**Figure 6. Typical Crossover Cable Connection**

## LinkMD<sup>®</sup> Cable Diagnostics

The LinkMD<sup>®</sup> function utilizes time domain reflectometry (TDR) to analyze the cabling plant for common cabling problems, such as open circuits, short circuits and impedance mismatches.

LinkMD<sup>®</sup> works by sending a pulse of known amplitude and duration down the MDI or MDI-X pair, and then analyzing the shape of the reflected signal to determine the type of fault. The time duration for the reflected signal to return provides the approximate distance to the cabling fault. The LinkMD<sup>®</sup> function processes this TDR information and presents it as a numerical value that can be translated to a cable distance.

LinkMD<sup>®</sup> is initiated by accessing register 1Dh, the LinkMD<sup>®</sup> Control/Status Register, in conjunction with register 1Fh, the PHY Control 2 Register. The latter register is used to disable auto MDI/MDI-X and to select either MDI or MDI-X as the cable differential pair for testing.

## NAND Tree Support

The KSZ8021/31RNL provides parametric NAND tree support for fault detection between chip I/Os and board. The NAND tree is a chain of nested NAND gates in which each KSZ8021/31RNL digital I/O (NAND tree input) pin is an input to one NAND gate along the chain. At the end of the chain, the TXD1 pin provides the output for the nested NAND gates.

The NAND tree test process includes:

- Enabling NAND tree mode
- Pulling all NAND tree input pins high
- Driving low each NAND tree input pin sequentially per the NAND tree pin order
- Checking the NAND tree output to ensure there is a toggle high-to-low or low-to-high for each NAND tree input driven low

Table 5 lists the NAND tree pin order.

Pin Number	Pin Name	NAND Tree Description
10	MDIO	Input
11	MDC	Input
12	RXD1	Input
13	RXD0	Input
15	CRS_DV	Input
16	REF_CLK	Input
17	RXER	Input
18	INTRP	Input
19	TXEN	Input
20	TXD0	Input
23	LED0	Input
21	TXD1	Output

**Table 5. NAND Tree Test Pin Order – for KSZ8021/31RNL**

## NAND Tree I/O Testing

The following procedure can be used to check for faults on the KSZ8021/31RNL digital I/O pin connections to the board:

1. Enable NAND tree mode by setting register 16h, bit [5] to '1'.
2. Use board logic to drive all KSZ8021/31RNL NAND tree input pins high.
3. Use board logic to drive each NAND tree input pin, per KSZ8021/31RNL NAND Tree pin order, as follow:
  - a. Toggle the first pin (MDIO) from high to low, and verify the TXD1 pin switch from low to high to indicate that the first pin is connected properly.
  - b. Leave the first pin (MDIO) low.
  - c. Toggle the second pin (MDC) from high to low, and verify the TXD1 pin switch from high to low to indicate that the second pin is connected properly.
  - d. Leave the first pin (MDIO) and the second pin (MDC) low.
  - e. Toggle the third pin from high to low, and verify the TXD1 pin switch from low to high to indicate that the third pin is connected properly.
  - f. Continue with this sequence until all KSZ8021/31RNL NAND tree input pins have been toggled.

Each KSZ8021/31RNL NAND tree input pin must cause the TXD1 output pin to toggle high-to-low or low-to-high to indicate a good connection. If the TXD1 pin fails to toggle when the KSZ8021/31RNL input pin toggles from high to low, then the input pin has a fault.

## Power Management

The KSZ8021/31RNL offers the following power management modes:

### Power Saving Mode

Power Saving Mode is used to reduce the transceiver power consumption when the cable is unplugged. It is enabled by writing a one to register 1Fh, bit [10], and is in effect when auto-negotiation mode is enabled and cable is disconnected (no link).

In this mode, the KSZ8021/31RNL turns off all transceiver blocks, except for transmitter, energy detect and PLL circuits.

By default, Power Saving Mode is disabled after power-up.

### Energy Detect Power Down Mode

Energy Detect Power Down (EDPD) Mode is used to further reduce the transceiver power consumption when the cable is un-plugged. It is enabled by writing a zero to register 18h, bit [11], and is in effect when auto-negotiation mode is enabled and cable is disconnected (no link).

EDPD Mode works in conjunction with PLL off (set by writing a one to register 10h, bit [4] to turn PLL off automatically in EDPD Mode) to turn off all KSZ8021/31RNL transceiver blocks, except for transmitter and energy detect circuits.

Further power consumption is achieved by extending the time interval in between transmissions of link pulses to check for the presence of a link partner. The periodic transmission of link pulses is needed to ensure two link partners in the same low power state and with auto MDI/MDI-X disabled can wake up when the cable is connected between them.

By default, Energy Detect Power Down Mode is disabled after power-up.

### Power Down Mode

Power Down Mode is used to power down the KSZ8021/31RNL device when it is not in use after power-up. It is enabled by writing a one to register 0h, bit [11].

In this mode, the KSZ8021/31RNL disables all internal functions, except for the MII management interface. The KSZ8021/31RNL exits (disables) Power Down Mode after register 0h, bit [11] is set back to zero.

### Slow Oscillator Mode

Slow Oscillator Mode is used to disconnect the input reference crystal/clock on XI (pin 8) and select the on-chip slow oscillator when the KSZ8021/31RNL device is not in use after power-up. It is enabled by writing a one to register 11h, bit [5].

Slow Oscillator Mode works in conjunction with Power Down Mode to put the KSZ8021/31RNL device in the lowest power state with all internal functions disabled, except for the MII management interface. To properly exit this mode and return to normal PHY operation, use the following programming sequence:

1. Disable Slow Oscillator Mode by writing a zero to register 11h, bit [5].
2. Disable Power Down Mode by writing a zero to register 0h, bit [11].
3. Initiate software reset by writing a one to register 0h, bit [15].

### Reference Circuit for Power and Ground Connections

The KSZ8021/31RNL is a single 3.3V supply device with a built-in regulator to supply the 1.2V core. The power and ground connections are shown in Figure 7 and Table 6 for 3.3V VDDIO.

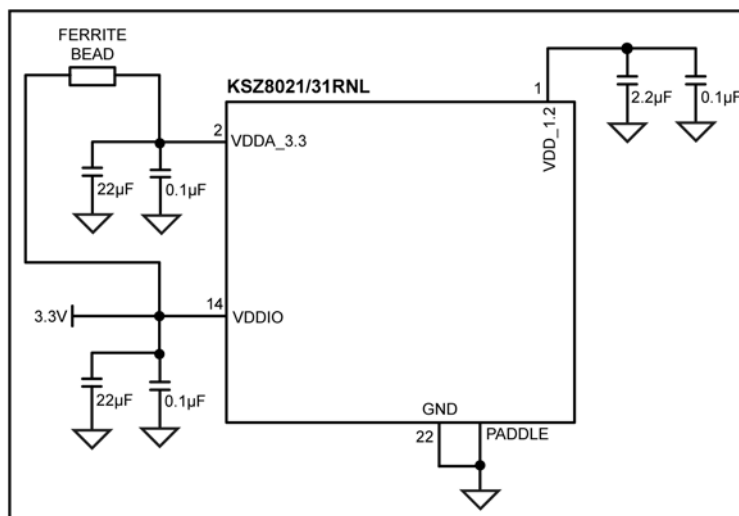

Figure 7. KSZ8021/31RNL Power and Ground Connections

Power Pin	Pin Number	Description
VDD_1.2	1	Decouple with 2.2µF and 0.1µF capacitors-to-ground.
VDDA_3.3	2	Connect to board's 3.3V supply through ferrite bead. Decouple with 22µF and 0.1µF capacitors-to-ground.
VDDIO	14	Connect to board's 3.3V supply for 3.3V VDDIO. Decouple with 22µF and 0.1µF capacitors-to-ground.

Table 6. KSZ8021/31RNL Power Pin Description

## Register Map

Register Number (Hex)	Description
0h	Basic Control
1h	Basic Status
2h	PHY Identifier 1
3h	PHY Identifier 2
4h	Auto-Negotiation Advertisement
5h	Auto-Negotiation Link Partner Ability
6h	Auto-Negotiation Expansion
7h	Auto-Negotiation Next Page
8h	Link Partner Next Page Ability
9h	Reserved
10h	Digital Reserved Control
11h	AFE Control 1
12h – 14h	Reserved
15h	RXER Counter
16h	Operation Mode Strap Override
17h	Operation Mode Strap Status
18h	Expanded Control
19h – 1Ah	Reserved
1Bh	Interrupt Control/Status
1Ch	Reserved
1Dh	LinkMD <sup>®</sup> Control/Status
1Eh	PHY Control 1
1Fh	PHY Control 2

## Register Description

Address	Name	Description	Mode <sup>(1)</sup>	Default
<b>Register 0h – Basic Control</b>				
0.15	Reset	1 = Software reset 0 = Normal operation This bit is self-cleared after a '1' is written to it.	RW/SC	0
0.14	Loop-back	1 = Loop-back mode 0 = Normal operation	RW	0
0.13	Speed Select	1 = 100Mbps 0 = 10Mbps This bit is ignored if auto-negotiation is enabled (register 0.12 = 1).	RW	Set by ANEN_SPEED strapping pin. See "Strapping Options" section for details.
0.12	Auto-Negotiation Enable	1 = Enable auto-negotiation process 0 = Disable auto-negotiation process If enabled, auto-negotiation result overrides settings in register 0.13 and 0.8.	RW	Set by ANEN_SPEED strapping pin. See "Strapping Options" section for details.

**Register Description (Continued)**

Address	Name	Description	Mode <sup>(1)</sup>	Default
<b>Register 0h – Basic Control</b>				
0.11	Power Down	1 = Power down mode 0 = Normal operation If software reset (register 0.15) is used to exit Power Down mode (register 0.11 = 1), two software reset writes (register 0.15 = 1) are required. First write clears Power Down mode; second write resets chip and re-latches the pin strapping pin values.	RW	0
0.10	Isolate	1 = Electrical isolation of PHY from MII 0 = Normal operation	RW	0
0.9	Restart Auto-Negotiation	1 = Restart auto-negotiation process 0 = Normal operation. This bit is self-cleared after a '1' is written to it.	RW/SC	0
0.8	Duplex Mode	1 = Full-duplex 0 = Half-duplex	RW	1
0.7	Collision Test	1 = Enable COL test 0 = Disable COL test	RW	0
0.6:0	Reserved		RO	000_0000
<b>Register 1h – Basic Status</b>				
1.15	100Base-T4	1 = T4 capable 0 = Not T4 capable	RO	0
1.14	100Base-TX Full Duplex	1 = Capable of 100Mbps full-duplex 0 = Not capable of 100Mbps full-duplex	RO	1
1.13	100Base-TX Half Duplex	1 = Capable of 100Mbps half-duplex 0 = Not capable of 100Mbps half-duplex	RO	1
1.12	10Base-T Full Duplex	1 = Capable of 10Mbps full-duplex 0 = Not capable of 10Mbps full-duplex	RO	1
1.11	10Base-T Half Duplex	1 = Capable of 10Mbps half-duplex 0 = Not capable of 10Mbps half-duplex	RO	1
1.10:7	Reserved		RO	000_0
1.6	No Preamble	1 = Preamble suppression 0 = Normal preamble	RO	1
1.5	Auto-Negotiation Complete	1 = Auto-negotiation process completed 0 = Auto-negotiation process not completed	RO	0
1.4	Remote Fault	1 = Remote fault 0 = No remote fault	RO/LH	0
1.3	Auto-Negotiation Ability	1 = Capable to perform auto-negotiation 0 = Not capable to perform auto-negotiation	RO	1

**Register Description (Continued)**

Address	Name	Description	Mode <sup>(1)</sup>	Default
1.2	Link Status	1 = Link is up 0 = Link is down	RO/LL	0
1.1	Jabber Detect	1 = Jabber detected 0 = Jabber not detected (default is low)	RO/LH	0
1.0	Extended Capability	1 = Supports extended capabilities registers	RO	1
<b>Register 2h – PHY Identifier 1</b>				
2.15:0	PHY ID Number	Assigned to the 3rd through 18th bits of the Organizationally Unique Identifier (OUI). Kendin Communication's OUI is 0010A1 (hex)	RO	0022h
<b>Register 3h – PHY Identifier 2</b>				
3.15:10	PHY ID Number	Assigned to the 19th through 24th bits of the Organizationally Unique Identifier (OUI). Kendin Communication's OUI is 0010A1 (hex)	RO	0001_01
3.9:4	Model Number	Six bit manufacturer's model number	RO	01_0101
3.3:0	Revision Number	Four bit manufacturer's revision number	RO	Indicates silicon revision
<b>Register 4h – Auto-Negotiation Advertisement</b>				
4.15	Next Page	1 = Next page capable 0 = No next page capability.	RW	0
4.14	Reserved		RO	0
4.13	Remote Fault	1 = Remote fault supported 0 = No remote fault	RW	0
4.12	Reserved		RO	0
4.11:10	Pause	[00] = No PAUSE [10] = Asymmetric PAUSE [01] = Symmetric PAUSE [11] = Asymmetric & Symmetric PAUSE	RW	00
4.9	100Base-T4	1 = T4 capable 0 = No T4 capability	RO	0
4.8	100Base-TX Full-Duplex	1 = 100Mbps full-duplex capable 0 = No 100Mbps full-duplex capability	RW	Set by ANEN_SPEED strapping pin. See "Strapping Options" section for details.
4.7	100Base-TX Half-Duplex	1 = 100Mbps half-duplex capable 0 = No 100Mbps half-duplex capability	RW	Set by ANEN_SPEED strapping pin. See "Strapping Options" section for details.
4.6	10Base-T Full-Duplex	1 = 10Mbps full-duplex capable 0 = No 10Mbps full-duplex capability	RW	1
4.5	10Base-T Half-Duplex	1 = 10Mbps half-duplex capable 0 = No 10Mbps half-duplex capability	RW	1
4.4:0	Selector Field	[00001] = IEEE 802.3	RW	0_0001

**Register Description (Continued)**

Address	Name	Description	Mode <sup>(1)</sup>	Default
<b>Register 5h – Auto-Negotiation Link Partner Ability</b>				
5.15	Next Page	1 = Next page capable 0 = No next page capability	RO	0
5.14	Acknowledge	1 = Link code word received from partner 0 = Link code word not yet received	RO	0
5.13	Remote Fault	1 = Remote fault detected 0 = No remote fault	RO	0
5.12	Reserved		RO	0
5.11:10	Pause	[00] = No PAUSE [10] = Asymmetric PAUSE [01] = Symmetric PAUSE [11] = Asymmetric & Symmetric PAUSE	RO	00
5.9	100Base-T4	1 = T4 capable 0 = No T4 capability	RO	0
5.8	100Base-TX Full-Duplex	1 = 100Mbps full-duplex capable 0 = No 100Mbps full-duplex capability	RO	0
5.7	100Base-TX Half-Duplex	1 = 100Mbps half-duplex capable 0 = No 100Mbps half-duplex capability	RO	0
5.6	10Base-T Full-Duplex	1 = 10Mbps full-duplex capable 0 = No 10Mbps full-duplex capability	RO	0
5.5	10Base-T Half-Duplex	1 = 10Mbps half-duplex capable 0 = No 10Mbps half-duplex capability	RO	0
5.4:0	Selector Field	[00001] = IEEE 802.3	RO	0_0001
<b>Register 6h – Auto-Negotiation Expansion</b>				
6.15:5	Reserved		RO	0000_0000_000
6.4	Parallel Detection Fault	1 = Fault detected by parallel detection 0 = No fault detected by parallel detection	RO/LH	0
6.3	Link Partner Next Page Able	1 = Link partner has next page capability 0 = Link partner does not have next page capability	RO	0
6.2	Next Page Able	1 = Local device has next page capability 0 = Local device does not have next page capability	RO	1
6.1	Page Received	1 = New page received 0 = New page not received yet	RO/LH	0
6.0	Link Partner Auto-Negotiation Able	1 = Link partner has auto-negotiation capability 0 = Link partner does not have auto-negotiation capability	RO	0

**Register Description (Continued)**

Address	Name	Description	Mode <sup>(1)</sup>	Default
<b>Register 7h – Auto-Negotiation Next Page</b>				
7.15	Next Page	1 = Additional next page(s) will follow 0 = Last page	RW	0
7.14	Reserved		RO	0
7.13	Message Page	1 = Message page 0 = Unformatted page	RW	1
7.12	Acknowledge2	1 = Will comply with message 0 = Cannot comply with message	RW	0
7.11	Toggle	1 = Previous value of the transmitted link code word equaled logic one 0 = Logic zero	RO	0
7.10:0	Message Field	11-bit wide field to encode 2048 messages	RW	000_0000_0001
<b>Register 8h – Link Partner Next Page Ability</b>				
8.15	Next Page	1 = Additional Next Page(s) will follow 0 = Last page	RO	0
8.14	Acknowledge	1 = Successful receipt of link word 0 = No successful receipt of link word	RO	0
8.13	Message Page	1 = Message page 0 = Unformatted page	RO	0
8.12	Acknowledge2	1 = Able to act on the information 0 = Not able to act on the information	RO	0
8.11	Toggle	1 = Previous value of transmitted link code word equal to logic zero 0 = Previous value of transmitted link code word equal to logic one	RO	0
8.10:0	Message Field		RO	000_0000_0000
<b>Register 10h – Digital Reserved Control</b>				
10.15:5	Reserved		RW	0000_0000_000
10.4	PLL off	1 = Turn PLL off automatically in EDPD mode. 0 = Keep PLL on in EDPD mode. See also register 18h, bit [11] for EDPD mode.	RW	0
10.3:0	Reserved		RW	0000
<b>Register 11h – AFE Control 1</b>				
11.15:6	Reserved		RW	0000_0000_00
11.5	Slow Oscillator Mode Enable	Slow Oscillator Mode is used to disconnect the input reference crystal/clock on the XI pin and select the on-chip slow oscillator when the KSZ8021/31RNL device is not in use after power-up. 1 = Enable 0 = Disable This bit automatically sets software power down to the analog side when enabled.	RW	0
11.4:0	Reserved		RW	0_0000

**Register Description (Continued)**

Address	Name	Description	Mode <sup>(1)</sup>	Default
<b>Register 15h – RXER Counter</b>				
15.15:0	RXER Counter	Receive error counter for Symbol Error frames	RO/SC	0000h
<b>Register 16h – Operation Mode Strap Override</b>				
16.15:11	Reserved		RW	0000_0
16.10	Reserved		RO	0
16.9:7	Reserved		RW	00_0
16.6	RMII B-to-B override	1 = Override strap-in for RMII Back-to-Back mode (set also bit 1 of this register to 1)	RW	0
16.5	NAND Tree override	1 = Override strap-in for NAND Tree mode	RW	0
16.4:2	Reserved		RW	0_00
16.1	RMII override	1 = Override strap-in for RMII mode	RW	1
16.0	Reserved		RW	0
<b>Register 17h – Operation Mode Strap Status</b>				
17.15:13	PHYAD[2:0] strap-in status	[000] = Strap to PHY Address 0 [011] = Strap to PHY Address 3 The KSZ8021/31RNL supports only PHY addresses 0x0h and 0x3h only.	RO	
17.12:2	Reserved		RO	
17.1	RMII strap-in status	1 = Strap to RMII mode	RO	
17.0	Reserved		RO	
<b>Register 18h – Expanded Control</b>				
18.15:12	Reserved		RW	0000
18.11	EDPD Disabled	Energy Detect Power Down (EDPD) mode 1 = Disable 0 = Enable See also register 10h, bit [4] for PLL off.	RW	1
18.10:0	Reserved		RW	000_0000_0000
<b>Register 1Bh – Interrupt Control/Status</b>				
1b.15	Jabber Interrupt Enable	1 = Enable Jabber Interrupt 0 = Disable Jabber Interrupt	RW	0
1b.14	Receive Error Interrupt Enable	1 = Enable Receive Error Interrupt 0 = Disable Receive Error Interrupt	RW	0
1b.13	Page Received Interrupt Enable	1 = Enable Page Received Interrupt 0 = Disable Page Received Interrupt	RW	0
1b.12	Parallel Detect Fault Interrupt Enable	1 = Enable Parallel Detect Fault Interrupt 0 = Disable Parallel Detect Fault Interrupt	RW	0

**Register Description (Continued)**

Address	Name	Description	Mode <sup>(1)</sup>	Default
1b.11	Link Partner Acknowledge Interrupt Enable	1 = Enable Link Partner Acknowledge Interrupt 0 = Disable Link Partner Acknowledge Interrupt	RW	0
1b.10	Link Down Interrupt Enable	1 = Enable Link Down Interrupt 0 = Disable Link Down Interrupt	RW	0
1b.9	Remote Fault Interrupt Enable	1 = Enable Remote Fault Interrupt 0 = Disable Remote Fault Interrupt	RW	0
1b.8	Link Up Interrupt Enable	1 = Enable Link Up Interrupt 0 = Disable Link Up Interrupt	RW	0
1b.7	Jabber Interrupt	1 = Jabber occurred 0 = Jabber did not occurred	RO/SC	0
1b.6	Receive Error Interrupt	1 = Receive Error occurred 0 = Receive Error did not occurred	RO/SC	0
1b.5	Page Receive Interrupt	1 = Page Receive occurred 0 = Page Receive did not occur	RO/SC	0
1b.4	Parallel Detect Fault Interrupt	1 = Parallel Detect Fault occurred 0 = Parallel Detect Fault did not occur	RO/SC	0
1b.3	Link Partner Acknowledge Interrupt	1 = Link Partner Acknowledge occurred 0 = Link Partner Acknowledge did not occur	RO/SC	0
1b.2	Link Down Interrupt	1 = Link Down occurred 0 = Link Down did not occur	RO/SC	0
1b.1	Remote Fault Interrupt	1 = Remote Fault occurred 0 = Remote Fault did not occur	RO/SC	0
1b.0	Link Up Interrupt	1 = Link Up occurred 0 = Link Up did not occur	RO/SC	0

**Register 1Dh – LinkMD<sup>®</sup> Control/Status**

1d.15	Cable Diagnostic Test Enable	1 = Enable cable diagnostic test. After test has completed, this bit is self-cleared. 0 = Indicates cable diagnostic test (if enabled) has completed and the status information is valid for read.	RW/SC	0
1d.14:13	Cable Diagnostic Test Result	[00] = normal condition [01] = open condition has been detected in cable [10] = short condition has been detected in cable [11] = cable diagnostic test has failed	RO	00
1d.12	Short Cable Indicator	1 = Short cable (<10 meter) has been detected by LinkMD <sup>®</sup> .	RO	0
1d.11:9	Reserved		RW	000
1d.8:0	Cable Fault Counter	Distance to fault	RO	0_0000_0000

**Register Description (Continued)**

Address	Name	Description	Mode <sup>(1)</sup>	Default
<b>Register 1Eh – PHY Control 1</b>				
1e.15:10	Reserved		RO	0000_00
1e.9	Enable Pause (Flow Control)	1 = Flow control capable 0 = No flow control capability	RO	0
1e.8	Link Status	1 = Link is up 0 = Link is down	RO	0
1e.7	Polarity Status	1 = Polarity is reversed 0 = Polarity is not reversed	RO	
1e.6	Reserved		RO	0
1e.5	MDI/MDI-X State	1 = MDI-X 0 = MDI	RO	
1e.4	Energy Detect	1 = Presence of signal on receive differential pair 0 = No signal detected on receive differential pair	RO	0
1e.3	PHY Isolate	1 = PHY in isolate mode 0 = PHY in normal operation	RW	0
1e.2:0	Operation Mode Indication	[000] = still in auto-negotiation [001] = 10Base-T half-duplex [010] = 100Base-TX half-duplex [011] = reserved [100] = reserved [101] = 10Base-T full-duplex [110] = 100Base-TX full-duplex [111] = reserved	RO	000
<b>Register 1Fh – PHY Control 2</b>				
1f.15	HP_MDIX	1 = HP Auto MDI/MDI-X mode 0 = Micrel Auto MDI/MDI-X mode	RW	1
1f.14	MDI/MDI-X Select	When Auto MDI/MDI-X is disabled, 1 = MDI-X Mode Transmit on RXP,RXM (pins 4,3) and Receive on TXP,TXM (pins 6,5) 0 = MDI Mode Transmit on TXP,TXM (pins 6,5) and Receive on RXP,RXM (pins 4,3)	RW	0
1f.13	Pair Swap Disable	1 = Disable auto MDI/MDI-X 0 = Enable auto MDI/MDI-X	RW	0
1f.12	Reserved		RW	0
1f.11	Force Link	1 = Force link pass 0 = Normal link operation This bit bypasses the control logic and allow transmitter to send pattern even if there is no link.	RW	0

**Register Description (Continued)**

Address	Name	Description	Mode <sup>(1)</sup>	Default
1f.10	Power Saving	1 = Enable power saving 0 = Disable power saving	RW	0
1f.9	Interrupt Level	1 = Interrupt pin active high 0 = Interrupt pin active low	RW	0
1f.8	Enable Jabber	1 = Enable jabber counter 0 = Disable jabber counter	RW	1
1f.7	RMII Reference Clock Select	1 = RMII – 50MHz Clock Mode; clock input to XI (pin 8) is 50MHz 0 = RMII – 25MHz Clock Mode; clock input to XI (pin 8) is 25MHz	RW	1 (for KSZ8021RNL) 0 (for KSZ8031RNL)
1f.6	Reserved		RW	0
1f.5:4	LED mode	[00] = LED0 : Link/Activity [01] = LED0 : Link [10], [11] = Reserved	RW	00
1f.3	Disable Transmitter	1 = Disable transmitter 0 = Enable transmitter	RW	0
1f.2	Remote Loop-back	1 = Remote (analog) loop back is enable 0 = Normal mode	RW	0
1f.1	Reserved		RW	0
1f.0	Disable Data Scrambling	1 = Disable scrambler 0 = Enable scrambler	RW	0

**Note:**

1. RW = Read/Write.  
RO = Read only.  
SC = Self-cleared.  
LH = Latch high.  
LL = Latch low.

**Absolute Maximum Ratings<sup>(1)</sup>**

Supply Voltage	
(V <sub>DD_1.2</sub> )	-0.5V to +1.8V
(V <sub>DDIO, V<sub>DDA_3.3</sub></sub> )	-0.5V to +4.0V
Input Voltage (all inputs)	-0.5V to +4.0V
Output Voltage (all outputs)	-0.5V to +4.0V
Lead Temperature (soldering, 10sec.)	260°C
Storage Temperature (T <sub>s</sub> )	-55°C to +150°C

**Operating Ratings<sup>(2)</sup>**

Supply Voltage	
(V <sub>DDIO_3.3, V<sub>DDA_3.3</sub></sub> )	+3.135V to +3.465V
(V <sub>DDIO_2.5</sub> )	+2.375V to +2.625V
(V <sub>DDIO_1.8</sub> )	+1.710V to +1.890V
Ambient Temperature	
(T <sub>A, Commercial</sub> )	0°C to +70°C
(T <sub>A, Industrial</sub> )	-40°C to +85°C
Maximum Junction Temperature (T <sub>J Max</sub> )	125°C
Thermal Resistance (θ <sub>JA</sub> )	49.22°C/W
Thermal Resistance (θ <sub>JC</sub> )	25.65°C/W

**Electrical Characteristics<sup>(3)</sup>**

Symbol	Parameter	Condition	Min.	Typ.	Max.	Units
<b>Supply Current (V<sub>DDIO, V<sub>DDA_3.3</sub></sub> = 3.3V)<sup>(4)</sup></b>						
I <sub>DD1</sub>	10Base-T	Full-Duplex Traffic @ 100% Utilization		45		mA
I <sub>DD2</sub>	100Base-TX	Full-Duplex Traffic @ 100% Utilization		49		mA
I <sub>DD3</sub>	Power Saving Mode	Ethernet Cable Disconnected (reg. 1F.10 = 1)		30		mA
I <sub>DD4</sub>	Power Down Mode	Software Power Down (reg. 0.11 = 1)		3.0		mA
<b>CMOS Level Inputs</b>						
V <sub>IH</sub>	Input High Voltage	V <sub>DDIO</sub> = 3.3V	2.0			V
		V <sub>DDIO</sub> = 2.5V	1.8			
		V <sub>DDIO</sub> = 1.8V	1.3			
V <sub>IL</sub>	Input Low Voltage	V <sub>DDIO</sub> = 3.3V			0.8	V
		V <sub>DDIO</sub> = 2.5V			0.7	
		V <sub>DDIO</sub> = 1.8V			0.5	
I <sub>IN</sub>	Input Current	V <sub>IN</sub> = GND ~ V <sub>DDIO</sub>		-10	10	µA
<b>CMOS Level Outputs</b>						
V <sub>OH</sub>	Output High Voltage	V <sub>DDIO</sub> = 3.3V	2.4			V
		V <sub>DDIO</sub> = 2.5V	2.0			
		V <sub>DDIO</sub> = 1.8V	1.5			
V <sub>OL</sub>	Output Low Voltage	V <sub>DDIO</sub> = 3.3V			0.4	V
		V <sub>DDIO</sub> = 2.5V			0.4	
		V <sub>DDIO</sub> = 1.8V			0.3	
I <sub>oz</sub>	Output Tri-State Leakage				10	µA
<b>LED Output</b>						
I <sub>LED</sub>	Output Drive Current	LED0 pin		8		mA
<b>Strapping Pins</b>						
pu	Internal Pull-Up Resistance	V <sub>DDIO</sub> = 3.3V	29	43	76	KΩ
		V <sub>DDIO</sub> = 2.5V	37	59	102	
		V <sub>DDIO</sub> = 1.8V	57	100	187	
pd	Internal Pull-Down Resistance	V <sub>DDIO</sub> = 3.3V	27	43	76	KΩ
		V <sub>DDIO</sub> = 2.5V	35	60	110	
		V <sub>DDIO</sub> = 1.8V	55	100	190	

**Electrical Characteristics<sup>(3)</sup> (Continued)**

Symbol	Parameter	Condition	Min.	Typ.	Max.	Units
<b>100Base-TX Transmit (measured differentially after 1:1 transformer)</b>						
V <sub>O</sub>	Peak Differential Output Voltage	100Ω Termination Across Differential Output	0.95		1.05	V
V <sub>IMB</sub>	Output Voltage Imbalance	100Ω Termination Across Differential Output			2	%
t <sub>r</sub> , t <sub>f</sub>	Rise/Fall Time		3		5	ns
	Rise/Fall Time Imbalance		0		0.5	
	Duty-Cycle Distortion				± 0.25	
	Overshoot				5	%
V <sub>SET</sub>	Reference Voltage of ISET			0.65		V
	Output Jitter	Peak-to-Peak		0.7	1.4	ns
<b>10Base-T Transmit (measured differentially after 1:1 transformer)</b>						
V <sub>P</sub>	Peak Differential Output Voltage	100Ω Termination Across Differential Output	2.2		2.8	V
	Jitter Added	Peak-to-Peak			3.5	ns
t <sub>r</sub> , t <sub>f</sub>	Rise/Fall Time			25		ns
<b>10Base-T Receive</b>						
V <sub>SQ</sub>	Squelch Threshold	5MHz Square Wave		400		mV
<b>REF_CLK Output</b>						
	50MHz RMII Clock Output Jitter	Peak-to-Peak (Applies to RMII – 50MHz Clock Mode only)		600		ps

**Notes:**

1. Exceeding the absolute maximum rating may damage the device. Stresses greater than the absolute maximum rating may cause permanent damage to the device. Operation of the device at these or any other conditions above those specified in the operating sections of this specification is not implied. Maximum conditions for extended periods may affect reliability.
2. The device is not guaranteed to function outside its operating rating.
3. T<sub>A</sub> = 25°C. Specification is for packaged product only.
4. Current consumption is for the single 3.3V supply KSZ8021/31RNL device only, and includes the transmit driver current and the 1.2V supply voltage (V<sub>DD\_1.2</sub>) that are supplied by the KSZ8021/31RNL.

## Timing Diagrams

### RMII Timing

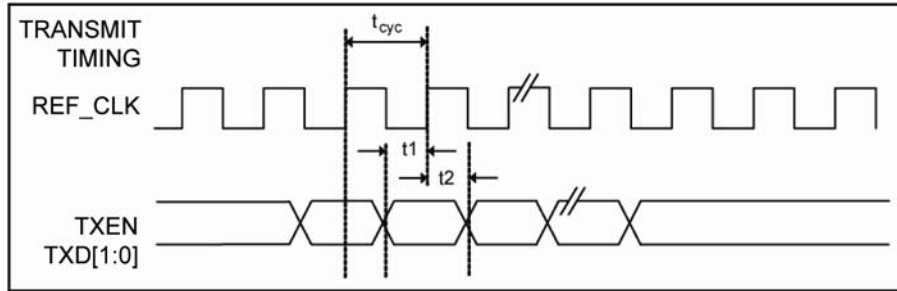

Figure 8. RMII Timing – Data Received from RMII

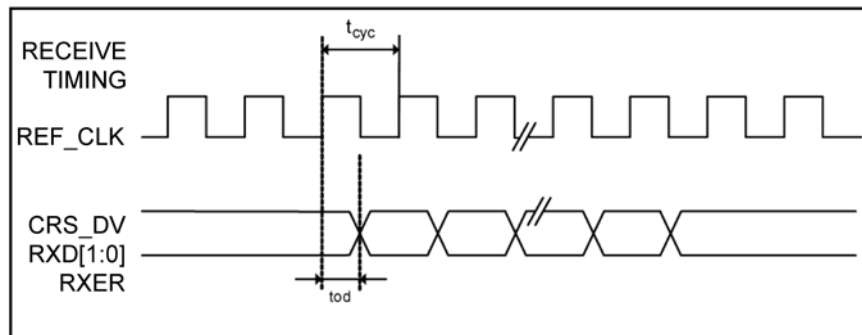

Figure 9. RMII Timing – Data Input to RMII

Timing Parameter	Description	Min.	Typ.	Max.	Unit
$t_{cyc}$	Clock cycle		20		ns
$t_1$	Setup time	4			ns
$t_2$	Hold time	2			ns
$t_{od}$	Output delay	7	9	13	ns

Table 7. RMII Timing Parameters – KSZ8021/31RNL (25MHz input to XI pin, 50MHz output from REF\_CLK pin)

Timing Parameter	Description	Min.	Typ.	Max.	Unit
$t_{cyc}$	Clock cycle		20		ns
$t_1$	Setup time	4			ns
$t_2$	Hold time	8			ns
$t_{od}$	Output delay	9	13	15	ns

Table 8. RMII Timing Parameters – KSZ8021/31RNL (50MHz input to XI pin)

Auto-Negotiation Timing

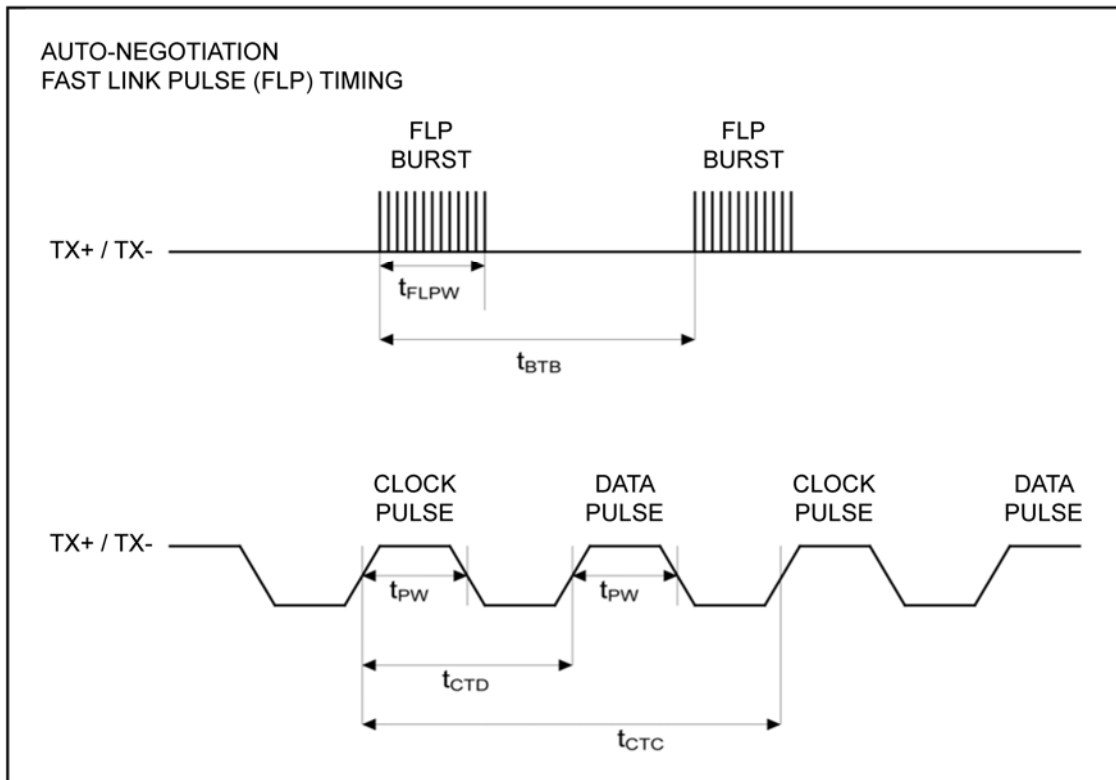
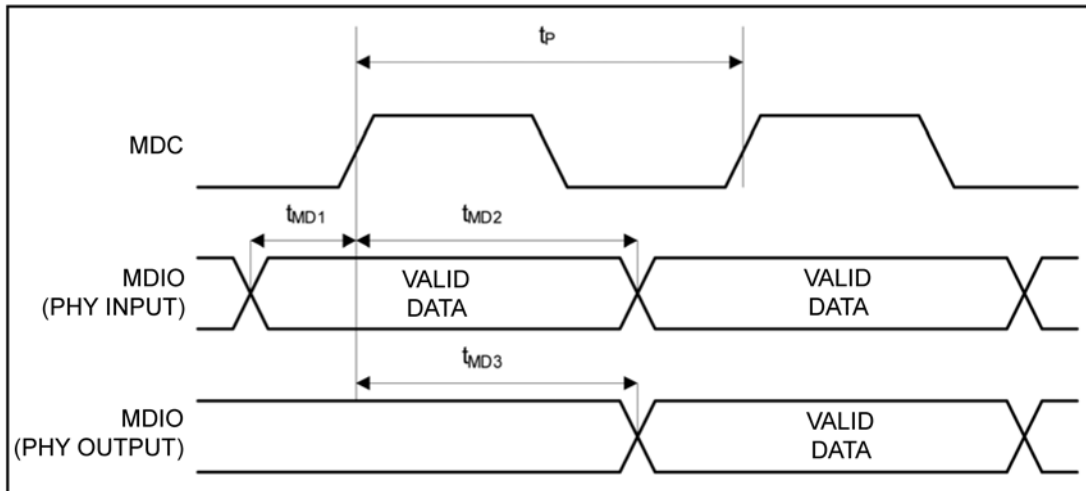

Figure 10. Auto-Negotiation Fast Link Pulse (FLP) Timing

Timing Parameter	Description	Min.	Typ.	Max.	Units
$t_{BTB}$	FLP Burst to FLP Burst	8	16	24	ms
$t_{FLPW}$	FLP Burst width		2		ms
$t_{PW}$	Clock/Data Pulse width		100		ns
$t_{CTD}$	Clock Pulse to Data Pulse	55.5	64	69.5	$\mu$ s
$t_{CTC}$	Clock Pulse to Clock Pulse	111	128	139	$\mu$ s
	Number of Clock/Data Pulse per FLP Burst	17		33	

Table 9. Auto-Negotiation Fast Link Pulse (FLP) Timing Parameters

**MDC/MDIO Timing**



**Figure 11. MDC/MDIO Timing**

Timing Parameter	Description	Min.	Typ.	Max.	Unit
$t_p$	MDC period		400		ns
$t_{1MD1}$	MDIO (PHY input) setup to rising edge of MDC	10			ns
$t_{MD2}$	MDIO (PHY input) hold from rising edge of MDC	4			ns
$t_{MD3}$	MDIO (PHY output) delay from rising edge of MDC * [can vary with MDC clock frequency]		*		ns

**Table 10. MDC/MDIO Timing Parameters**

**Reset Timing**

The KSZ8021/31RNL reset timing requirement is summarized in Figure 12 and Table 11.

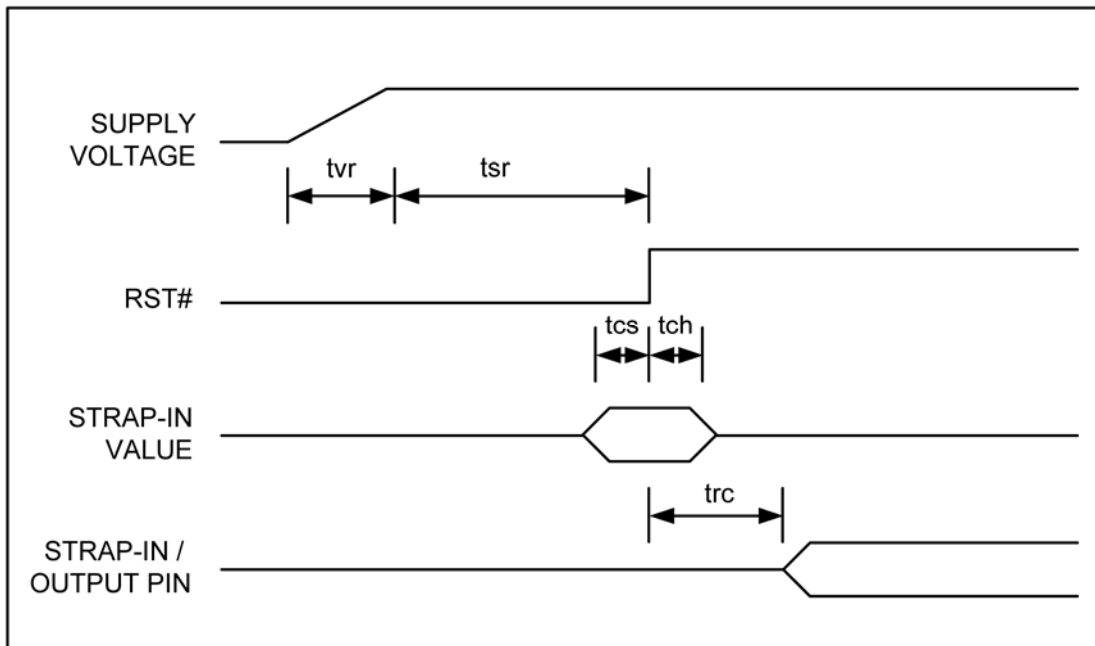

**Figure 12. Reset Timing**

Parameter	Description	Min.	Max.	Units
$t_{vr}$	Supply voltage ( $V_{DDIO}$ , $V_{DDA_{3,3}}$ ) rise time	300		$\mu s$
$t_{sr}$	Stable supply voltage ( $V_{DDIO}$ , $V_{DDA_{3,3}}$ ) to reset high	10		ms
$t_{cs}$	Configuration setup time	5		ns
$t_{ch}$	Configuration hold time	5		ns
$t_{rc}$	Reset to strap-in pin output	6		ns

**Table 11. Reset Timing Parameters**

The supply voltage ( $V_{DDIO}$ , and  $V_{DDA_{3,3}}$ ) power-up waveform should be monotonic, and the 300 $\mu s$  minimum rise time is from 10% to 90%.

After the de-assertion of reset, it is recommended to wait a minimum of 100 $\mu s$  before starting programming on the MIIM (MDC/MDIO) Interface.

## Reset Circuit

The following reset circuit is recommended for powering up the KSZ8021/31RNL if reset is triggered by the power supply.

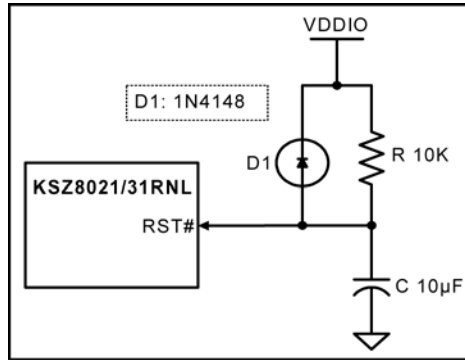

Figure 13. Recommended Reset Circuit

The following reset circuit is recommended for applications where reset is driven by another device (e.g., CPU or FPGA). At power-on-reset, R, C and D1 provide the necessary ramp rise time to reset the KSZ8021/31RNL device. The RST\_OUT\_n from CPU/FPGA provides the warm reset after power up.

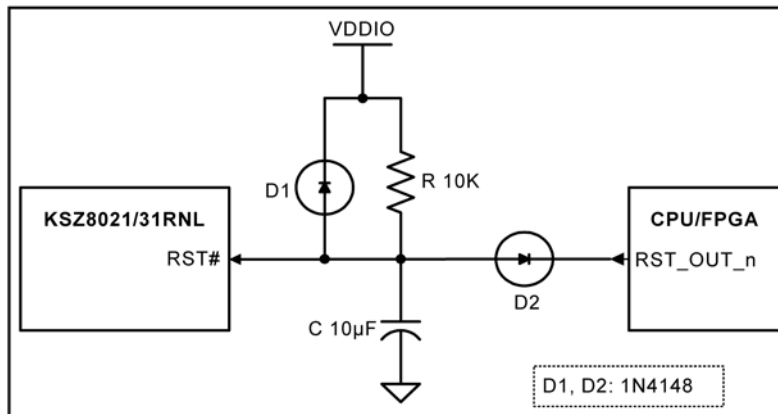

Figure 14. Recommended Reset Circuit for interfacing with CPU/FPGA Reset Output

## Reference Circuit for LED Strapping Pin

The pull-up, float and pull-down reference circuits for the LED0/ANEN\_SPEED strapping pin are shown in Figure 15 for 3.3V and 2.5V VDDIO.

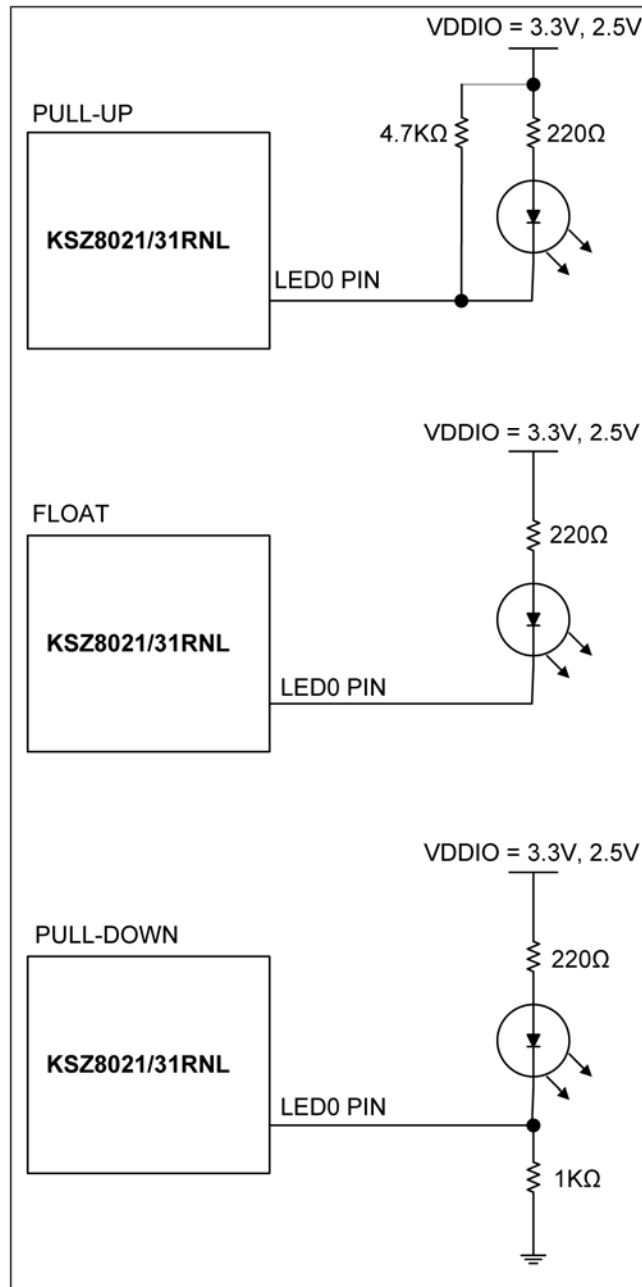

Figure 15. Reference Circuits for LED Strapping Pin

For 1.8V VDDIO, LED indication support is not recommended due to the low voltage. Without the LED indicator, the ANEN\_SPEED strapping pin is functional with 4.7K pull-up to 1.8V VDDIO or float for a value of '1', and with 1.0K pull-down to ground for a value of '0'.

## Magnetics Specification

A 1:1 isolation transformer is required at the line interface. An isolation transformer with integrated common-mode chokes is recommended for exceeding FCC requirements.

Tables 12 and 13 list recommended magnetic characteristics and qualified magnetics for the KSZ8021/31RNL.

Parameter	Value	Test Condition
Turns ratio	1 CT : 1 CT	
Open-circuit inductance (min.)	350 $\mu$ H	100mV, 100kHz, 8mA
Insertion loss (max.)	-1.0dB	100kHz – 100MHz
HIPOT (min.)	1500Vrms	

Table 12. Magnetics Selection Criteria

Magnetic Manufacturer	Part Number	Auto MDI-X	Number of Port
Bel Fuse	S558-5999-U7	Yes	1
Bel Fuse (Mag Jack)	SI-46001-F	Yes	1
Bel Fuse (Mag Jack)	SI-50170-F	Yes	1
Delta	LF8505	Yes	1
LANKom	LF-H41S-1	Yes	1
Pulse	H1102	Yes	1
Pulse (low cost)	H1260	Yes	1
Transpower	HB726	Yes	1
TDK (Mag Jack)	TLA-6T718A	Yes	1

Table 13. Qualified Single Port 10/100 Magnetics

## Reference Clock – Connection and Selection

A crystal or external clock source, such as an oscillator, is used to provide the reference clock for the KSZ8021/31RNL.

For the KSZ8021/31RNL in RMII – 25MHz Clock Mode, the reference clock is 25MHz. The reference clock connections to XI (Pin 8) and XO (Pin 7), and the reference clock selection criteria are provided in Figure 16 and Table 14.

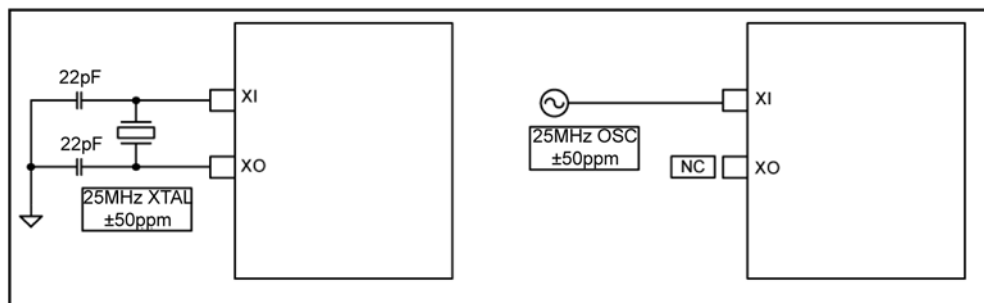
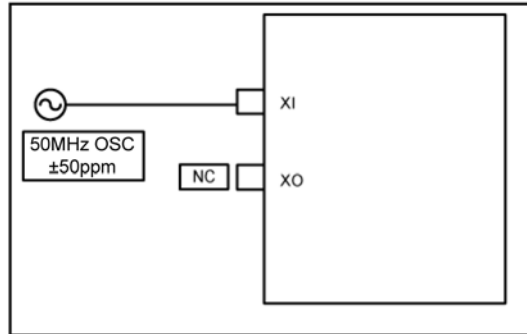

Figure 16. 25MHz Crystal / Oscillator Reference Clock Connection

Characteristics	Value	Units
Frequency	25	MHz
Frequency tolerance (max)	±50	ppm

**Table 14. 25MHz Crystal / Reference Clock Selection Criteria**

For the KSZ8021/31RNL in RMII – 50MHz Clock Mode, the reference clock is 50MHz. The reference clock connection to XI (Pin 8), and the reference clock selection criteria are provided in Figure 17 and Table 15.

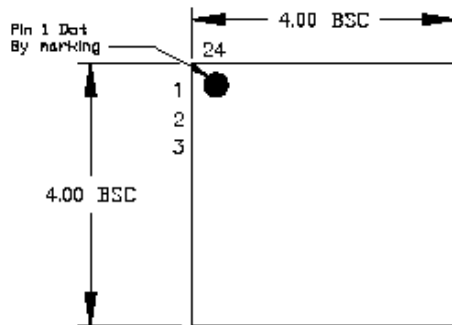

**Figure 17. 50MHz Oscillator Reference Clock Connection**

Characteristics	Value	Units
Frequency	50	MHz
Frequency tolerance (max)	±50	ppm

**Table 15. 50MHz Oscillator / Reference Clock Selection Criteria**

## Package Information



TOP VIEW

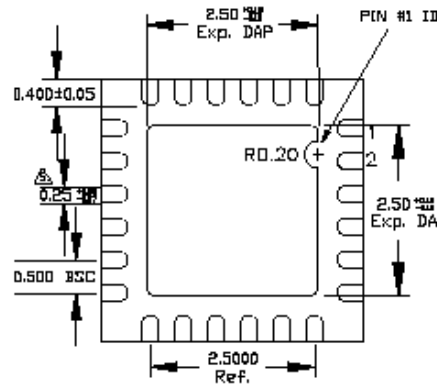

BOTTOM VIEW

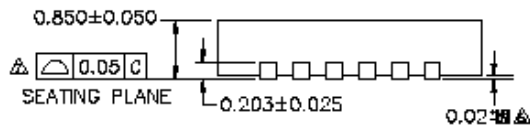

SIDE VIEW

### NOTE:

1. ALL DIMENSIONS ARE IN MILLIMETERS.
  2. MAX. PACKAGE WARPAGE IS 0.05 mm.
  3. MAXIMUM ALLOWABLE BURRS IS 0.076 mm IN ALL DIRECTIONS.
  4. PIN #1 ID ON TOP WILL BE LASER/INK MARKED.
- DIMENSION APPLIES TO METALIZED TERMINAL AND IS MEASURED BETWEEN 0.20 AND 0.25 mm FROM TERMINAL TIP.  
 APPLIED ONLY FOR TERMINALS.  
 APPLIED FOR EXPOSED PAD AND TERMINALS.

### 24-Pin (4mm x 4mm) QFN

**MICREL, INC. 2180 FORTUNE DRIVE SAN JOSE, CA 95131 USA**  
 TEL +1 (408) 944-0800 FAX +1 (408) 474-1000 WEB <http://www.micrel.com>

Micrel makes no representations or warranties with respect to the accuracy or completeness of the information furnished in this data sheet. This information is not intended as a warranty and Micrel does not assume responsibility for its use. Micrel reserves the right to change circuitry, specifications and descriptions at any time without notice. No license, whether express, implied, arising by estoppel or otherwise, to any intellectual property rights is granted by this document. Except as provided in Micrel's terms and conditions of sale for such products, Micrel assumes no liability whatsoever, and Micrel disclaims any express or implied warranty relating to the sale and/or use of Micrel products including liability or warranties relating to fitness for a particular purpose, merchantability, or infringement of any patent, copyright or other intellectual property right.

Micrel Products are not designed or authorized for use as components in life support appliances, devices or systems where malfunction of a product can reasonably be expected to result in personal injury. Life support devices or systems are devices or systems that (a) are intended for surgical implant into the body or (b) support or sustain life, and whose failure to perform can be reasonably expected to result in a significant injury to the user. A Purchaser's use or sale of Micrel Products for use in life support appliances, devices or systems is a Purchaser's own risk and Purchaser agrees to fully indemnify Micrel for any damages resulting from such use or sale.

© 2010 Micrel, Incorporated.

## Looking for pricing, stock, or lifecycle information?

Click below to explore more details on WIN SOURCE:

- ⊖ [View KSZ8031RNL-TR on WIN SOURCE](#)
- ⊖ [Microchip Technology](#) Information

## Optimize Your Supply Chain with WIN SOURCE Solutions

- ✓ Global Sourcing Solution
- ✓ Obsolete Management
- ✓ Cost Control Management
- ✓ Shortage Management
- ✓ Alternative Solution
- ✓ Excess Inventory Management