



**THE DATASHEET OF
KS8993FL**





KS8993F/KS8993FL

Single Chip Fast Ethernet Media Converter with TS-1000 OAM

Revision 1.3

General Description

The Micrel KS8993F is the industry's first single chip Fast Ethernet Media Converter with built-in OAM functions. The KS8993F integrates three MACs, two PHYs, OAM, frame buffer and high performance switch into a single chip. It is ideal for use in 100BASE-FX to 10BASE-T or 100BASE-TX conversion in the FTTx market.

The KS8993F provides remote loop back and OAM (Operation, Administration and Maintenance) to manage subscriber access network from carrier center side to terminal side.

The KS8993F supports advanced features such as rate limiting, force flow control and link transparency.

The KS8993F with built-in Layer 2 switch capability will filter packets and forward them to valid destination. It will discard any unwanted frames and frames with invalid destination.

The KS8993FL is the single supply version with all the identical rich features of the KS8993F.

Features

- First single-chip 10BASE-T/100BASE-TX to 100BASE-FX media converter with TS-1000 OAM
- Integrated 3-Port 10/100 Ethernet Switch with 3 MACs and 2 PHYs
- Unique User Defined Register (UDR) feature brings OAM to low cost/complexity nodes
- Automatic MDI/MDI-X crossover with disable and enable option
- Non-blocking switch fabric assures fast packet delivery by utilizing an 1K MAC Address lookup table and a store-and-forward architecture
- Comprehensive LED indicator support for link, activity, full/half duplex and 10/100 speed
- Full complement of MII/SNI, SPI, MIIM, SMI and I2C interfaces
- Low Power Dissipation: < 800mW (includes PHY transmit drivers)

Block Diagram

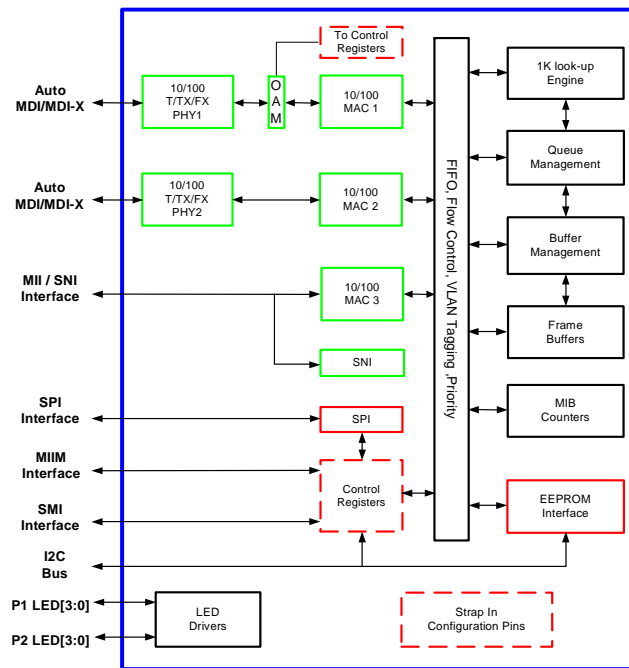

KS8993F / KS8993FL

Micrel is a registered trademark of Micrel, Inc.

Micrel Inc. • 2180 Fortune Drive • San Jose, CA 95131 • USA • tel +1 (408) 944-0800 • fax + 1 (408) 474-1000 • <http://www.micrel.com>

June 2009

M9999-062509
hbwhelp@micrel.com or (408) 955-1690

Features (continued)

- **OAM Features:**
- Supports OAM sub-layer which conforms to TS-1000 specification from TTC (Telecommunication Technology Committee)
- Sends and receives OAM frames to Center or Terminal side
- Loop back mode to support loop back packet from Center side to Terminal side
- Far-end fault detection with disable and enable
- Link Transparency to indicate the link down from link partner
- **Comprehensive Configuration Register access:**
- Serial Management Interface (SMI) to all internal registers
- MII Management (MIIM) Interface to PHY registers
- SPI and I2C Interface to all internal registers
- I/O Pins Strapping and EEPROM to program selective registers in unmanaged switch mode
- Control registers configurable on the fly (port-priority, 802.1p/d/q, AN...)
- **QoS / CoS packets prioritization support**
- per-port, 802.1p and DiffServ based
- Re-mapping of 802.1p priority field per-port basis
- **Advanced Switch Features**
- IEEE 802.1q VLAN support for up to 16 groups (full-range of VLAN ID)
- VLAN ID tag/untag options, per-port basis
- IEEE 802.1p/q tag insertion or removal on a per port basis (egress)
- Programmable Rate Limiting from 0 to 100 Mbps at the ingress & egress port, rate options for high & low priority, per port basis
- Broadcast storm protection with % control (global & per-port basis)
- Double Tagging support

- **Switch Management Features:**
- Port mirroring/monitoring/sniffing: ingress and/or egress traffic to any port or MII
- MIB (Management Information Base) counters for fully compliant statistics gathering, 34 MIB counters per port
- Full-chip hardware power-down (register configuration not saved)
- Per-port based software power-save on PHY (idle link detection, register configuration preserved)
- 0.18um CMOS technology
- Voltages:
 - Core 1.8V
 - I/O and Transceiver 3.3V
- **Available in 128-pin PQFP**

Ordering Information

Part Number		Temperature Range	Package
Pb-Free	Standard		
KSZ8993F	KS8993F	0°– 70° C	128-PQFP
KSZ8993FL	KS8993FL	0°– 70° C	128-PQFP

Revision History

Revision	Date	Summary of Changes
P0	1/14/03	Preliminary Information
P1	2/11/03	Added separate Link and activity on port 1 and port 2's LED (pin #20, pin #23, pin #25). Added disable auto MDI/MDIX (pin #28) Added select of MDI and MDIX (pin #29)
P2	4/1/03	Updated register information
P3	12/4/03	Started overhaul of datasheet. Updated strap option definition for pin #85. Renamed supply voltages and ground references to match schematics. Corrected Remote Loop back path. Updated MC registers descriptions. Changed 3.3V voltage pins to (3.3V or 2.5V).
P4	3/11/04	Completed overhaul of datasheet. Revised datasheet format. Updated KS8993F block diagram. Updated Feature Highlights. Updated MC registers descriptions. Updated Electrical Characteristics (Vih, Vil, Voh, Vol).
P5	3/23/04	Updated MC loop back description in pin #19 and register 11 bits[3:2], and path in loop back diagram. Updated flow diagram for Destination Address resolution flowchart, stage2. Changed S10 status bit from RO to R/W in register 81 bit[2]. Added KS8993FL to General Description (page 1) and Functional Description Overview (section 2.1). Updated pin description for pin 22 to the following: VDDC : For KS8993F, this is an input power pin for the 1.8V digital core VDD. VOUT_1V8 : For KS8993FL, this is an 1.8V output power pin to supply the KS8993FL's input power pins: VDDAP (pin 63), VDDC (pins 91, 123) and VDDA (pins 38, 43, 57). Improved/clarified pin description.
1.0	8/26/04	Updated PPM spec for 25 MHz crystal/oscillator. Improved/clarified pin description for P1LCRCD (pin 18), P2MDIX (pin 29) and MDIO (pin 95). Corrected aging time. Removed loop back support from MIIM and Port Control Registers, so that there is no confusion with MC loop back which is used exclusively in KS8993F application. Updated HWPOVR description in section 2.2.5. Corrected default definition for FEF in section 2.3.6, and MIIM and Port Control Registers. Added register note to indicate port sniffing is not supported if the unicast packets can cross VLAN boundary bit is set. Improved/clarified switch/PHY registers descriptions for Force MDIX and CRC drop. Improved/clarified MC registers descriptions for Remote Command (registers 74, 75, 76), My Status (registers 80, 81) and LNK Partner Status (registers 88, 89). Added register note to set Register 85: My Model Info (1) to values of 0x22, 0x26, 0x2A and 0x2E if the Remote Command feature is used. Updated MIB counters descriptions to indicate counter overflow must be tracked by application.
1.1	4/7/05	Corrected VDDIO, VDDATX, VDDARX supply pins to 3.3V only. Updated reset timing requirement. Corrected 10BASE-T Transmitter Jitters Added.
1.2	5/22/06	Removed Industrial Temperature line from Features and Ordering info.
1.3	6/25/09	Add the parts KSZ8993F, KSZ8993FL on the order information

Table Of Contents

1	Signal Description.....	9
1.1	KS8993F Pin Diagram	9
1.2	Pin Description and I/O Assignment	10
2	Functional Description	20
2.1	Overview	20
2.2	Media Converter Function.....	20
2.2.1	OAM (Operations, Administration, and Management) Frame Format	20
2.2.2	MC (Media Converter) Mode	22
2.2.3	MC Loop Back Function	22
2.2.4	Registers for Media Converter Functions	23
2.2.5	Unique I/O Feature Definition	23
2.2.6	Port 1 LED Indicator Definition	24
2.2.7	Port 2 LED Indicator Definition	24
2.3	Physical Transceiver	25
2.3.1	100BASE-TX Transmit	25
2.3.2	100BASE-TX Receive	25
2.3.3	PLL Clock Synthesizer	25
2.3.4	Scrambler/De-scrambler (100BASE-TX only)	25
2.3.5	100BASE-FX Operation and Signal Detection	25
2.3.6	100BASE-FX Far-End Fault (FEF)	26
2.3.7	10BASE-T Transmit and Receive	26
2.3.8	Power Management.....	27
2.3.9	Auto MDI/MDI-X Crossover	27
2.3.10	Auto Negotiation	29
2.4	MAC and Switch Function.....	29
2.4.1	Address Look Up	29
2.4.2	Learning.....	30
2.4.3	Migration.....	30
2.4.4	Aging	30
2.4.5	Forwarding.....	30
2.4.6	Switching Engine	33
2.4.7	MAC operation.....	33
2.4.8	Back-off Algorithm	33
2.4.9	Late Collision	33
2.4.10	Illegal Frames	33
2.4.11	Flow Control	33
2.4.12	Half Duplex Back Pressure.....	34
2.4.13	Broadcast Storm Protection.....	34
2.5	MII Interface Operation	34
2.6	SNI (7-wire) Interface Operation	35
2.7	MII Management Interface (MIIM)	36
2.8	Serial Management Interface (SMI)	36
2.9	Advanced Switch Function.....	37
2.9.1	Port Mirroring Support	37
2.9.2	IEEE 802.1Q VLAN support	38
2.9.3	QoS Priority	39
2.9.4	Rate Limit Support.....	41
2.10	Configuration Interface.....	41
2.10.1	I ² C Master Serial Bus Configuration	42
2.10.2	I ² C Slave Serial Bus Configuration	43
2.10.3	SPI Slave Serial Bus Configuration	43
3	MII Management (MIIM) Registers	47
	Register 0: MII Basic Control	47
	Register 1: MII Basic Status.....	48
	Register 2: PHYID HIGH	48
	Register 3: PHYID LOW.....	48
	Register 4: Auto-Negotiation Advertisement Ability	49

Register 5: Auto-Negotiation Link Partner Ability	49
4 Register Map: Switch, MC, & PHY (8 bits registers)	50
4.1 Global Registers.....	51
Register 0 (0x00): Chip ID0.....	51
Register 1 (0x01): Chip ID1 / Start Switch.....	51
Register 2 (0x02): Global Control 0.....	51
Register 3 (0x03): Global Control 1.....	52
Register 4 (0x04): Global Control 2.....	53
Register 5 (0x05): Global Control 3.....	53
Register 6 (0x06): Global Control 4.....	54
Register 7 (0x07): Global Control 5.....	55
Register 8 (0x08): Global Control 6.....	55
Register 9 (0x09): Global Control 7.....	55
Register 10 (0x0A): Global Control 8.....	55
Register 11 (0x0B): Global Control 9.....	55
Register 12 (0x0C): Reserved Register	56
Register 13 (0x0D): User Defined Register 1.....	56
Register 14 (0x0E): User Defined Register 2.....	57
Register 15 (0x0F): User Defined Register 3.....	57
4.2 Port Registers	57
Register 16 (0x10): Port 1 Control 0	57
Register 17 (0x11): Port 1 Control 1	58
Register 18 (0x12): Port 1 Control 2	58
Register 19 (0x13): Port 1 Control 3	59
Register 20 (0x14): Port 1 Control 4	59
Register 21 (0x15): Port 1 Control 5	60
Register 22 (0x16): Port 1 Control 6	60
Register 23 (0x17): Port 1 Control 7	60
Register 24 (0x18): Port 1 Control 8	60
Register 25 (0x19): Port 1 Control 9	60
Register 26 (0x1A): Port 1 Control 10.....	60
Register 27 (0x1B): Port 1 Control 11.....	61
Register 28 (0x1C): Port 1 Control 12.....	61
Register 29 (0x1D): Port 1 Control 13.....	62
Register 30 (0x1E): Port 1 Status 0	63
Register 31 (0x1F): Port 1 Status 1.....	64
4.3 Media Converter Registers	65
Register 64 (0x40): PHY Address	65
Register 65 (0x41): Center Side Status	65
Register 66 (0x42): Center Side Command.....	66
Register 67 (0x43): PHY-SW Initialize	66
Register 68 (0x44): Loop Back Setup1	68
Register 69 (0x45): Loop Back Setup2.....	68
Register 70 (0x46): Loop Back Result Counter for CRC Error.....	69
Register 71 (0x47): Loop Back Result Counter for Timeout.....	69
Register 72 (0x48): Loop Back Result Counter for Good Packet.....	69
Register 73 (0x49): Additional Status (Center and Terminal side).....	69
Register 74 (0x4A): Remote Command 1	70
Register 75 (0x4B): Remote Command 2	70
Register 76 (0x4C): Remote Command 3.....	71
Register 77 (0x4D): Valid MC Packet Transmitted Counter.....	71
Register 78 (0x4E): Valid MC Packet Received Counter	71
Register 79 (0x4F): Shadow of 0x58h Register	71
Register 80 (0x50): My Status 1 (Terminal and Center side).....	72
Register 81 (0x51): My Status 2.....	72
Register 82 (0x52): My Vendor Info (1).....	73
Register 83 (0x53): My Vendor Info (2).....	73
Register 84 (0x54): My Vendor Info (3).....	73
Register 85 (0x55): My Model Info (1).....	73
Register 86 (0x56): My Model Info (2).....	73
Register 87 (0x57): My Model Info (3).....	73

Register 88 (0x58): LNK Partner Status (1)	74
Register 89 (0x59): LNK Partner Status (2)	74
Register 90 (0x5A): LNK Partner Vendor Info (1).....	74
Register 91 (0x5B): LNK Partner Vendor Info (2).....	74
Register 92 (0x5C): LNK Partner Vendor Info (3)	74
Register 93 (0x5D): LNK Partner Model Info (1)	74
Register 94 (0x5E): LNK Partner Model Info (2)	74
Register 95 (0x5F): LNK Partner Model Info (3).....	74
4.4 Advanced Control Registers	75
Register 96 (0x60): TOS Priority Control Register 0	75
Register 97 (0x61): TOS Priority Control Register 1	75
Register 98 (0x62): TOS Priority Control Register 2	75
Register 99 (0x63): TOS Priority Control Register 3	75
Register 100 (0x64): TOS Priority Control Register 4	75
Register 101 (0x65): TOS Priority Control Register 5	75
Register 102 (0x66): TOS Priority Control Register 6	75
Register 103 (0x67): TOS Priority Control Register 7	75
Register 104 (0x68): MAC Address Register 0	76
Register 105 (0x69): MAC Address Register 1	76
Register 106 (0x6A): MAC Address Register 2	76
Register 107 (0x6B): MAC Address Register 3.....	76
Register 108 (0x6C): MAC Address Register 4.....	76
Register 109 (0x6D): MAC Address Register 5.....	76
Register 110 (0x6E): Indirect Access Control 0	76
Register 111 (0x6F): Indirect Access Control 1	76
Register 112 (0x70): Indirect Data Register 8.....	77
Register 113 (0x71): Indirect Data Register 7.....	77
Register 114 (0x72): Indirect Data Register 6.....	77
Register 115 (0x73): Indirect Data Register 5.....	77
Register 116 (0x74): Indirect Data Register 4.....	77
Register 117 (0x75): Indirect Data Register 3.....	77
Register 118 (0x76): Indirect Data Register 2.....	77
Register 119 (0x77): Indirect Data Register 1.....	77
Register 120 (0x78): Indirect Data Register 0.....	77
Register 121 (0x79): Digital Testing Status 0.....	77
Register 122 (0x7A): Digital Testing Status 1	77
Register 123 (0x7B): Digital Testing Control 0.....	78
Register 124 (0x7C): Digital Testing Control 1.....	78
Register 125 (0x7D): Analog Testing Control 0.....	78
Register 126 (0x7E): Analog Testing Control 1.....	78
Register 127 (0x7F): Analog Testing Status	78
4.5 Static MAC Address Table	78
4.6 VLAN Table.....	79
4.7 Dynamic MAC Address Table	80
4.8 MIB (Management Information Base) Counters.....	81
5 Electrical Specifications	86
5.1 Absolute Maximum Ratings	86
5.2 Recommended Operating Conditions	86
5.3 Electrical Characteristics.....	87
5.4 100BASE-FX Electrical Specification.....	88
6 Timing Specifications.....	89
6.1 EEPROM Timing.....	89
6.2 SNI Timing	90
6.3 MII Timing	91
6.3.1 MAC Mode MII Timing	91
6.3.2 PHY Mode MII Timing.....	92
6.3.3 SPI Timing.....	92
6.3.4 MDC/MDIO Timing.....	95
6.3.5 Auto Negotiation Timing	96
6.4 Reset Timing	97
6.5 Reset Circuit.....	98

7 Selection of Isolation Transformer99
8 Selection of Crystal/Oscillator99
9 Package Information.....100

List of Tables

Table 1: FX and TX Mode Selection.....	26
Table 2: MDI/MDI-X Pin Definition.....	27
Table 3: MII Signals.....	35
Table 4: SNI (7-wire) Signals.....	35
Table 5: MII Management Interface frame format.....	36
Table 6: Serial Management Interface (SMI) frame format.....	37
Table 7: FID+DA look up in VLAN mode.....	39
Table 8: FID+SA look up in VLAN mode.....	39
Table 9: KS8993F SPI Connections.....	44
Table 10: Format of Static MAC Table (8 entries).....	79
Table 11: Format of Static VLAN Table (16 entries).....	80
Table 12: Format of Dynamic MAC Table (1K entries).....	81
Table 13: Format of “Per Port” MIB Counters.....	82
Table 14: Port 1’s “Per Port” MIB Counters Indirect Memory Offsets.....	82
Table 15: Format of “All Port Dropped Packet” MIB Counters.....	84
Table 16: “All Port Dropped Packet” MIB Counters Indirect Memory Offsets.....	84
Table 17: EEPROM Timing Parameters.....	89
Table 18: SNI Timing Parameters.....	90
Table 19: MAC mode MII Timing Parameters.....	91
Table 20: PHY Mode MII Timing Parameters.....	92
Table 21: SPI Input Timing Parameters.....	93
Table 22: SPI Output Timing Parameters.....	94
Table 23: Reset Timing Parameters.....	97
Table 24: Transformer Selection Criteria.....	99
Table 25: Qualified Single Port Magnetic.....	99
Table 26: Crystal/Oscillator Selection Criteria.....	99

List of Figures

Figure 1: Typical Straight Cable Connection.....	28
Figure 2: Typical Crossover Cable Connection.....	28
Figure 3: Auto Negotiation and Parallel Detection.....	29
Figure 4: Destination Address look up flowchart, stage 1.....	31
Figure 5: Destination Address resolution flowchart, stage 2.....	32
Figure 6: 802.1p Priority Field Format.....	40
Figure 7: KS8993F EEPROM Configuration Timing Diagram.....	42
Figure 8: SPI Write Data Cycle.....	45
Figure 9: SPI Read Data Cycle.....	45
Figure 10: SPI Multiple Write.....	46
Figure 11: SPI Multiple Read.....	46
Figure 12: EEPROM Interface Input Timing Diagram.....	89
Figure 13: EEPROM Interface Output Timing Diagram.....	89
Figure 14: SNI Input Timing Diagram.....	90
Figure 15: SNI Output Timing Diagram.....	90
Figure 16: MAC Mode MII Timing - Data received from MII.....	91
Figure 17: MAC Mode MII Timing - Data transmitted to MII.....	91
Figure 18: PHY Mode MII Timing – Data received from MII.....	92
Figure 19: PHY Mode MII Timing - Data transmitted to MII.....	92
Figure 20: SPI Input Timing.....	93
Figure 21: SPI Output Timing.....	94
Figure 22: MDC/MDIO Timing for MIIM and SMI Interfaces.....	95
Figure 23: Auto Negotiation Timing.....	96
Figure 24: Reset Timing.....	97
Figure 25: Recommended Reset Circuit.....	98
Figure 26: Recommended Reset Circuit for interfacing with CPU/FPGA Reset Output.....	98
Figure 27: 128-pin PQFP Package Outline Drawing.....	100

1 Signal Description

1.1 KS8993F Pin Diagram

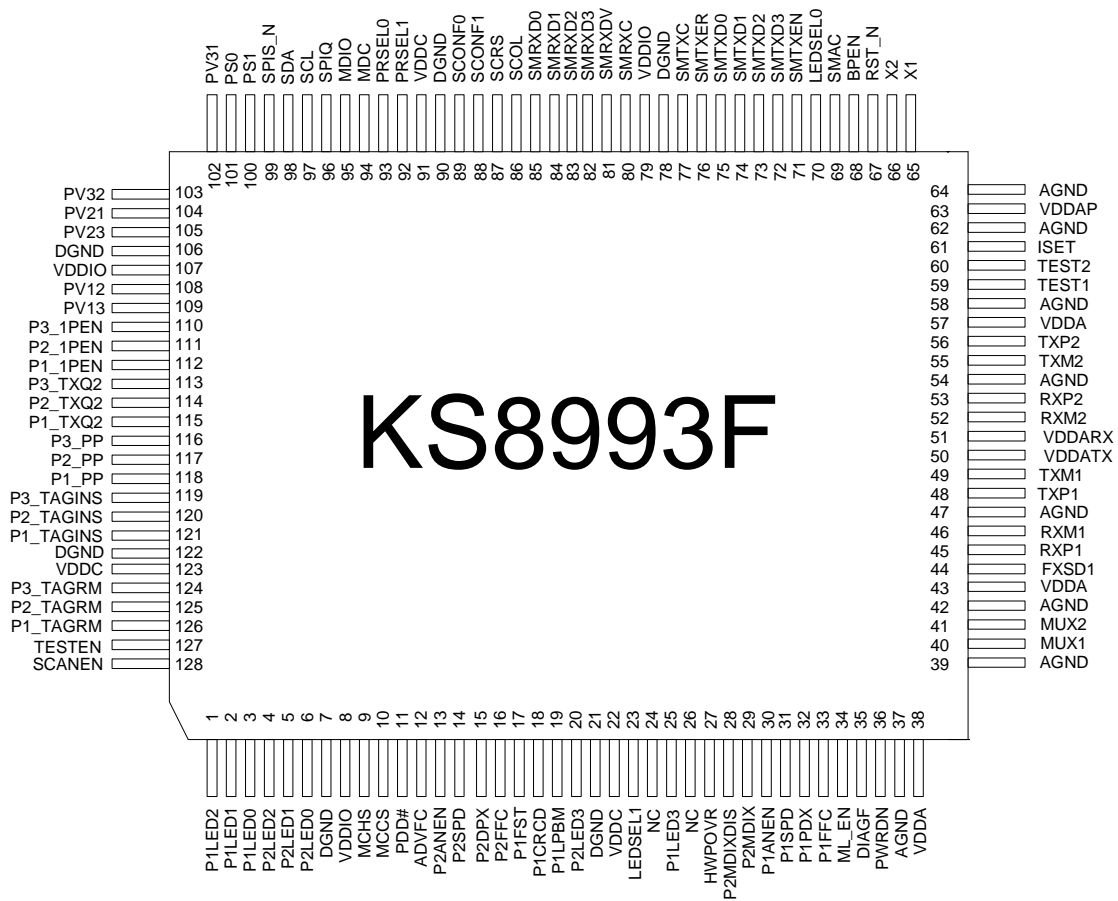

1.2 Pin Description and I/O Assignment

Pin #	Pin Name	Type	Description																																				
1	P1LED2	I(pu)/O	Port 1 LED indicators, defined as below:																																				
2	P1LED1	I(pu)/O																																					
3	P1LED0	I(pu)/O																																					
			<table border="1"> <thead> <tr> <th colspan="3">[LEDSEL1, LEDSEL0]</th> </tr> <tr> <th></th> <th>[0,0]</th> <th>[0,1]</th> </tr> </thead> <tbody> <tr> <td>P1LED3</td> <td>-----</td> <td>-----</td> </tr> <tr> <td>P1LED2</td> <td>LINK/ACT</td> <td>100LINK/ACT</td> </tr> <tr> <td>P1LED1</td> <td>FULLD/COL</td> <td>10LINK/ACT</td> </tr> <tr> <td>P1LED0</td> <td>SPEED</td> <td>FULL_DPX</td> </tr> </tbody> </table> <table border="1"> <thead> <tr> <th colspan="3">[LEDSEL1, LEDSEL0]</th> </tr> <tr> <th></th> <th>[1,0]</th> <th>[1,1]</th> </tr> </thead> <tbody> <tr> <td>P1LED3</td> <td>ACT</td> <td>-----</td> </tr> <tr> <td>P1LED2</td> <td>LINK</td> <td>-----</td> </tr> <tr> <td>P1LED1</td> <td>FULL_DPX/COL</td> <td>-----</td> </tr> <tr> <td>P1LED0</td> <td>SPEED</td> <td>-----</td> </tr> </tbody> </table> <p>Notes: LEDSEL0 is external strap-in pin #70. LEDSEL1 is external strap-in pin #23. P1LED3 is pin #25. During reset, P1LED[2:0] are inputs for internal testing.</p>	[LEDSEL1, LEDSEL0]				[0,0]	[0,1]	P1LED3	-----	-----	P1LED2	LINK/ACT	100LINK/ACT	P1LED1	FULLD/COL	10LINK/ACT	P1LED0	SPEED	FULL_DPX	[LEDSEL1, LEDSEL0]				[1,0]	[1,1]	P1LED3	ACT	-----	P1LED2	LINK	-----	P1LED1	FULL_DPX/COL	-----	P1LED0	SPEED	-----
[LEDSEL1, LEDSEL0]																																							
	[0,0]	[0,1]																																					
P1LED3	-----	-----																																					
P1LED2	LINK/ACT	100LINK/ACT																																					
P1LED1	FULLD/COL	10LINK/ACT																																					
P1LED0	SPEED	FULL_DPX																																					
[LEDSEL1, LEDSEL0]																																							
	[1,0]	[1,1]																																					
P1LED3	ACT	-----																																					
P1LED2	LINK	-----																																					
P1LED1	FULL_DPX/COL	-----																																					
P1LED0	SPEED	-----																																					
4	P2LED2	I(pu)/O	Port 2 LED indicators, defined as below:																																				
5	P2LED1	I(pu)/O																																					
6	P2LED0	I(pu)/O																																					
			<table border="1"> <thead> <tr> <th colspan="3">[LEDSEL1, LEDSEL0]</th> </tr> <tr> <th></th> <th>[0,0]</th> <th>[0,1]</th> </tr> </thead> <tbody> <tr> <td>P2LED3</td> <td>-----</td> <td>-----</td> </tr> <tr> <td>P2LED2</td> <td>LINK/ACT</td> <td>100LINK/ACT</td> </tr> <tr> <td>P2LED1</td> <td>FULLD/COL</td> <td>10LINK/ACT</td> </tr> <tr> <td>P2LED0</td> <td>SPEED</td> <td>FULL_DPX</td> </tr> </tbody> </table> <table border="1"> <thead> <tr> <th colspan="3">[LEDSEL1, LEDSEL0]</th> </tr> <tr> <th></th> <th>[1,0]</th> <th>[1,1]</th> </tr> </thead> <tbody> <tr> <td>P2LED3</td> <td>ACT</td> <td>-----</td> </tr> <tr> <td>P2LED2</td> <td>LINK</td> <td>-----</td> </tr> <tr> <td>P2LED1</td> <td>FULL_DPX/COL</td> <td>-----</td> </tr> <tr> <td>P2LED0</td> <td>SPEED</td> <td>-----</td> </tr> </tbody> </table> <p>Notes: LEDSEL0 is external strap-in pin #70. LEDSEL1 is external strap-in pin #23. P2LED3 is pin #20. During reset, P2LED[2:0] are inputs for internal testing.</p>	[LEDSEL1, LEDSEL0]				[0,0]	[0,1]	P2LED3	-----	-----	P2LED2	LINK/ACT	100LINK/ACT	P2LED1	FULLD/COL	10LINK/ACT	P2LED0	SPEED	FULL_DPX	[LEDSEL1, LEDSEL0]				[1,0]	[1,1]	P2LED3	ACT	-----	P2LED2	LINK	-----	P2LED1	FULL_DPX/COL	-----	P2LED0	SPEED	-----
[LEDSEL1, LEDSEL0]																																							
	[0,0]	[0,1]																																					
P2LED3	-----	-----																																					
P2LED2	LINK/ACT	100LINK/ACT																																					
P2LED1	FULLD/COL	10LINK/ACT																																					
P2LED0	SPEED	FULL_DPX																																					
[LEDSEL1, LEDSEL0]																																							
	[1,0]	[1,1]																																					
P2LED3	ACT	-----																																					
P2LED2	LINK	-----																																					
P2LED1	FULL_DPX/COL	-----																																					
P2LED0	SPEED	-----																																					
7	DGND	Gnd	Digital ground																																				
8	VDDIO	Pwr	3.3V digital VDD																																				

Pin #	Pin Name	Type	Description											
9	MCHS	lpd	KS8993F operating modes, defined as below:											
10	MCCS	lpd												
				<table border="1"> <thead> <tr> <th>(MCHS, MCCS)</th> <th>Description</th> </tr> </thead> <tbody> <tr> <td>(0, 0)</td> <td>Normal 3 port switch mode (3 MAC + 2 PHY) MC mode is disabled. Port 1 is either Fiber or UTP. Port 2 is UTP. Port 3 (MII) is enabled.</td> </tr> <tr> <td>(0, 1)</td> <td>Center MC mode (3 MAC + 2 PHY) MC mode is enabled. Port 1 is Fiber and has Center MC enabled. Port 2 is UTP. Port 3 (MII) is enabled.</td> </tr> <tr> <td>(1, 0)</td> <td>Terminal MC mode (2 MAC + 2 PHY) MC mode is enabled. Port 1 is Fiber and has Terminal MC enabled. Port 2 is UTP. Port 3 (MII) is disabled.</td> </tr> <tr> <td>(1, 1)</td> <td>Terminal MC mode (3 MAC + 2 PHY) MC mode is enabled. Port 1 is Fiber and has Terminal MC enabled. Port 2 is UTP. Port 3 (MII) is enabled.</td> </tr> </tbody> </table>	(MCHS, MCCS)	Description	(0, 0)	Normal 3 port switch mode (3 MAC + 2 PHY) MC mode is disabled. Port 1 is either Fiber or UTP. Port 2 is UTP. Port 3 (MII) is enabled.	(0, 1)	Center MC mode (3 MAC + 2 PHY) MC mode is enabled. Port 1 is Fiber and has Center MC enabled. Port 2 is UTP. Port 3 (MII) is enabled.	(1, 0)	Terminal MC mode (2 MAC + 2 PHY) MC mode is enabled. Port 1 is Fiber and has Terminal MC enabled. Port 2 is UTP. Port 3 (MII) is disabled.	(1, 1)	Terminal MC mode (3 MAC + 2 PHY) MC mode is enabled. Port 1 is Fiber and has Terminal MC enabled. Port 2 is UTP. Port 3 (MII) is enabled.
(MCHS, MCCS)	Description													
(0, 0)	Normal 3 port switch mode (3 MAC + 2 PHY) MC mode is disabled. Port 1 is either Fiber or UTP. Port 2 is UTP. Port 3 (MII) is enabled.													
(0, 1)	Center MC mode (3 MAC + 2 PHY) MC mode is enabled. Port 1 is Fiber and has Center MC enabled. Port 2 is UTP. Port 3 (MII) is enabled.													
(1, 0)	Terminal MC mode (2 MAC + 2 PHY) MC mode is enabled. Port 1 is Fiber and has Terminal MC enabled. Port 2 is UTP. Port 3 (MII) is disabled.													
(1, 1)	Terminal MC mode (3 MAC + 2 PHY) MC mode is enabled. Port 1 is Fiber and has Terminal MC enabled. Port 2 is UTP. Port 3 (MII) is enabled.													
11	PDD#	lpu	<p>Power Down Detect 1 = normal operation 0 = power down detected</p> <p>In Terminal MC mode (pin MCHS is '1'), a high to low transition to this pin will cause port 1 (fiber) to generate and send out an "Indicate Terminal MC Condition" OAM frame with the S0 status bit set to '1'.</p>											
12	ADVFC	lpu	<p>1 = advertise the switch's flow control capability via auto negotiation. 0 = will not advertise the switch's flow control capability via auto negotiation.</p>											
13	P2ANEN	lpu	<p>1 = enable auto negotiation on port 2. 0 = disable auto negotiation on port 2.</p>											
14	P2SPD	lpd	<p>1 = Force port 2 to 100BT if P2ANEN = 0. 0 = Force port 2 to 10BT if P2ANEN = 0.</p>											
15	P2DPX	lpd	<p>1 = port 2 default to full duplex mode if P2ANEN = 1 and auto negotiation fails. Force port 2 in full duplex mode if P2ANEN = 0. 0 = port 2 default to half duplex mode if P2ANEN = 1 and auto negotiation fails. Force port 2 in half duplex mode if P2ANEN = 0.</p>											
16	P2FFC	lpd	<p>1 = always enable (force) port 2 flow control feature. 0 = port 2 flow control feature enable is determined by auto negotiation result.</p>											
17	P1FST	Opu	<p>1 = normal function 0 = MC in loop back mode, or MC abnormal conditions happen</p>											
18	P1LCRCD	lpd	<p>In MC loop back mode,</p> <p>1 = Drop OAM frames and Ethernet frames with the following errors –</p>											

Pin #	Pin Name	Type	Description
			CRC, undersize, oversize. Loop back Ethernet frames with only good CRC and valid length. 0 = Drop OAM frames only. Loop back all Ethernet frames including those with errors.
19	P1LPBM	l _{pd}	0 = perform MC loop back at MAC of port 2 1 = reserve. Do not use.
20	P2LED3	O _{pd}	Port 2 LED Indicator Note: Internal pull down is weak; it will not turn ON the LED. <i>See description in pin# (4).</i>
21	DGND	Gnd	Digital ground
22	VDDC / VOUT_1V8	Pwr	VDDC : For KS8993F, this is an input power pin for the 1.8V digital core VDD. VOUT_1V8 : For KS8993FL, this is an 1.8V output power pin to supply the KS8993FL's input power pins: VDDAP (pin 63), VDDC (pins 91, 123) and VDDA (pins 38, 43, 57).
23	LEDSEL1	l _{pd}	LED display mode select <i>See description in pin# (1,4).</i>
24	NC	O _{pd}	Reserved
25	P1LED3	O _{pd}	Port 1 LED Indicator Note: An external 1K pull down is needed on this pin if it is connected to a LED. <i>See description in pin# (1).</i>
26	NC	O _{pd}	Reserved
27	HWPOVR	l _{pd}	Hardware Pin Overwrite 0 = Disable. All strap-in pins configurations are overwritten by the EEPROM configuration data. 1 = Enable. All strap-in pins configurations are overwritten by the EEPROM configuration data, except for P2ANEN (pin 13), P2SPD (pin 14), P2DPX (pin 15) and ML_EN (pin 34).
28	P2MDIXDIS	l _{pd}	Port 2 auto MDI/MDI-X 0 = enable (default) 1 = disable
29	P2MDIX	l _{pd}	Port 2 MDI/MDI-X setting when auto MDI/MDI-X is disabled 0 = MDI-X (default), {transmit on TXP2/TXM2 pins} 1 = MDI, {transmit on RXP2/RXM2 pins}
30	P1ANEN	l _{pu}	1 = enable auto negotiation on port 1 0 = disable auto negotiation on port 1
31	P1SPD	l _{pd}	1 = Force port 1 to 100BT if P1ANEN = 0. 0 = Force port 1 to 10BT if P1ANEN = 0.
32	P1DPX	l _{pd}	1 = port 1 default to full duplex mode if P1ANEN = 1 and auto negotiation fails. Force port 1 in full duplex mode if P1ANEN = 0. 0 = port 1 default to half duplex mode if P1ANEN = 1 and auto negotiation fails. Force port 1 in half duplex mode if P1ANEN = 0.
33	P1FFC	l _{pd}	1 = always enable (force) port 1 flow control feature 0 = port 1 flow control feature enable is determined by auto negotiation result.
34	ML_EN	l _{pd}	1 = enable missing link

Pin #	Pin Name	Type	Description
			0 = disable missing link
35	DIAGF	lpd	1 = diagnostic fail 0 = diagnostic normal
36	PWRDN	l	Chip power down input (active low)
37	AGND	Gnd	Analog ground
38	VDDA	Pwr	1.8V analog VDD
39	AGND	Gnd	Analog ground
40	MUX1	l	Factory test pin – float for normal operation
41	MUX2	l	Factory test pin – float for normal operation
42	AGND	Gnd	Analog ground
43	VDDA	Pwr	1.8V analog VDD
44	FXSD1	l	Fiber signal detect / factory test pin
45	RXP1	I/O	Physical receive or transmit signal (+ differential)
46	RXM1	I/O	Physical receive or transmit signal (- differential)
47	AGND	Gnd	Analog ground
48	TXP1	I/O	Physical transmit or receive signal (+ differential)
49	TXM1	I/O	Physical transmit or receive signal (- differential)
50	VDDATX	Pwr	3.3V analog VDD
51	VDDARX	Pwr	3.3V analog VDD
52	RXM2	I/O	Physical receive or transmit signal (– differential)
53	RXP2	I/O	Physical receive or transmit signal (+ differential)
54	AGND	Gnd	Analog ground
55	TXM2	I/O	Physical transmit or receive signal (– differential)
56	TXP2	I/O	Physical transmit or receive signal (+ differential)
57	VDDA	Pwr	1.8V analog VDD
58	AGND	Gnd	Analog ground
59	TEST1	l	Factory test pin – float for normal operation
60	TEST2	l	Factory test pin – float for normal operation
61	ISET	O	Set physical transmit output current. Pull down this pin with a 3.01K 1% resistor to ground.
62	AGND	Gnd	Analog ground
63	VDDAP	Pwr	1.8V analog VDD for PLL
64	AGND	Gnd	Analog ground
65	X1	l	25 MHz crystal/oscillator clock connections Pins (X1, X2) connect to a crystal. If an oscillator is used, X1 connects to a 3.3V tolerant oscillator and X2 is a no connect. Note: Clock is +/- 50ppm for both crystal and oscillator.
66	X2	O	
67	RST_N	lpu	Hardware reset pin (active low)
68	BPEN	lpd	Half Duplex Backpressure 1 = enable 0 = disable
69	SMAC	lpd	Special Mac Mode In this mode, the switch will do faster backoffs than normal. 1 = enable 0 = disable
70	LEDSELO	lpd	LED display mode select <i>See description in pin# (1,4).</i>
71	SMTXEN	lpd	Switch MII transmit enable
72	SMTXD3	lpd	Switch MII transmit data bit 3

Pin #	Pin Name	Type	Description	
73	SMTXD2	lpd	Switch MII transmit data bit 2	
74	SMTXD1	lpd	Switch MII transmit data bit 1	
75	SMTXD0	lpd	Switch MII transmit data bit 0	
76	SMTXER	lpd	Switch MII transmit error	
77	SMTXC	lpd/O	Switch MII transmit clock Output in PHY MII mode Input in MAC MII mode	
78	DGND	Gnd	Digital ground	
79	VDDIO	Pwr	3.3V digital VDD	
80	SMRXC	lpd/O	Switch MII receive clock Output in PHY MII mode Input in MAC MII mode	
81	SMRXDV	O	Switch MII receive data valid	
82	SMRXD3	lpd/O	Switch MII receive data bit 3 Strap option: Switch MII full duplex flow control PD (default) = disable PU = enable	
83	SMRXD2	lpd / O	Switch MII receive bit 2 Strap option: Switch MII is in PD (default) = full duplex mode PU = half duplex mode	
84	SMRXD1	lpd/O	Switch MII receive bit 1 Strap option: Switch MII is in PD (default) = 100Mbps mode PU = 10Mbps mode	
85	SMRXD0	lpd/O	Switch MII receive bit 0 Strap option: Switch will accept packet size up to PD (default) = 1536 bytes (inclusive); PU = 1522 bytes (tagged), 1518 bytes (untagged)	
86	SCOL	lpd/O	Switch MII collision detect	
87	SCRS	lpd/O	Switch MII carrier sense	
88	SCONF1	lpd	Switch MII interface configuration	
89	SCONF0	lpd		
		(SCONF1, SCONF0)		Description
		(0,0)		disable, output tri-stated
		(0,1)	PHY mode MII	
		(1,0)	MAC mode MII	
		(1,1)	PHY mode SNI	
90	DGND	Gnd	Digital ground	
91	VDDC	Pwr	1.8V digital VDD	
92	PRSEL1	lpd	Priority Select Select queue servicing if using split queues. Use the table	

Pin #	Pin Name	Type	Description										
93	PRSELO	lpd	<p>below to select the desired servicing. Note that this selection affects all split transmit queue ports in the same way.</p> <table border="1"> <thead> <tr> <th>(PRSEL,PRSELO)</th> <th>Description</th> </tr> </thead> <tbody> <tr> <td>(0,0)</td> <td>Transmit all high priority before low priority</td> </tr> <tr> <td>(0,1)</td> <td>Transmit high priority and low priority at 10:1 ratio.</td> </tr> <tr> <td>(1,0)</td> <td>Transmit high priority and low priority at 5:1 ratio.</td> </tr> <tr> <td>(1,1)</td> <td>Transmit high priority and low priority at 2:1 ratio.</td> </tr> </tbody> </table>	(PRSEL,PRSELO)	Description	(0,0)	Transmit all high priority before low priority	(0,1)	Transmit high priority and low priority at 10:1 ratio.	(1,0)	Transmit high priority and low priority at 5:1 ratio.	(1,1)	Transmit high priority and low priority at 2:1 ratio.
(PRSEL,PRSELO)	Description												
(0,0)	Transmit all high priority before low priority												
(0,1)	Transmit high priority and low priority at 10:1 ratio.												
(1,0)	Transmit high priority and low priority at 5:1 ratio.												
(1,1)	Transmit high priority and low priority at 2:1 ratio.												
94	MDC	lpu	MII Management interface: clock input										
95	MDIO	lpu/O	<p>MII Management interface: data input/output</p> <p>Note: An external 4.7K pull up is needed on this pin when it is in use.</p>										
96	SPIQ	Opu	<p>SPI slave mode: serial data output</p> <p><i>See description in pin# (100, 101)</i></p>										
97	SCL	lpu/O	<p>SPI slave mode / I2C slave mode: clock input</p> <p>I2C master mode: clock output</p> <p><i>See description in pin# (100, 101)</i></p>										
98	SDA	lpu/O	<p>SPI slave mode: serial data input</p> <p>I2C master/slave mode: serial data input/output</p> <p><i>See description in pin# (100, 101)</i></p>										
99	SPIS_N	lpu	<p>SPI slave mode: chip select (active low)</p> <p>When SPIS_N is high, the KS8993F is deselected and SPIQ is held in high impedance state.</p> <p>A high-to-low transition is used to initiate SPI data transfer.</p> <p><i>See description in pin# (100, 101)</i></p>										
100	PS1	lpd	Serial bus configuration pins to select mode of access to KS8993F internal										

Pin #	Pin Name	Type	Description																																													
101	PS0	lpd	<p>registers.</p> <p>[PS1, PS0] = [0, 0] --- I2C master (EEPROM) mode (If EEPROM is not detected, the power up default values of the KS8993F internal registers will be used)</p> <table border="1"> <thead> <tr> <th>Interface Signals</th> <th>Type</th> <th>Description</th> </tr> </thead> <tbody> <tr> <td>SPIQ</td> <td>O</td> <td>Not used. (tri-stated)</td> </tr> <tr> <td>SCL</td> <td>O</td> <td>I2C clock</td> </tr> <tr> <td>SDA</td> <td>I/O</td> <td>I2C data I/O</td> </tr> <tr> <td>SPIS_N</td> <td>lpu</td> <td>Not used.</td> </tr> </tbody> </table> <p>[PS1, PS0] = [0, 1] --- I2C slave mode The external I2C master will drive the SCL clock. The KS8993F device addresses are: 1011_1111 <read> 1011_1110 <write></p> <table border="1"> <thead> <tr> <th>Interface Signals</th> <th>Type</th> <th>Description</th> </tr> </thead> <tbody> <tr> <td>SPIQ</td> <td>O</td> <td>Not used. (tri-stated)</td> </tr> <tr> <td>SCL</td> <td>I</td> <td>I2C clock</td> </tr> <tr> <td>SDA</td> <td>I/O</td> <td>I2C data I/O</td> </tr> <tr> <td>SPIS_N</td> <td>lpu</td> <td>Not used.</td> </tr> </tbody> </table> <p>[PS1, PS0] = [1, 0] --- SPI slave mode</p> <table border="1"> <thead> <tr> <th>Interface Signals</th> <th>Type</th> <th>Description</th> </tr> </thead> <tbody> <tr> <td>SPIQ</td> <td>O</td> <td>SPI Data Out</td> </tr> <tr> <td>SCL</td> <td>I</td> <td>SPI clock</td> </tr> <tr> <td>SDA</td> <td>I</td> <td>SPI Data In</td> </tr> <tr> <td>SPIS_N</td> <td>lpu</td> <td>SPI chip select</td> </tr> </tbody> </table> <p>[PS1, PS0] = [1, 1] --- SMI mode In this mode, the KS8993F provides access to all its internal 8 bit registers thru its MDC and MDIO pins.</p> <p>Note When (PS1, PS0) ≠ (1,1), the KS8993F provides access to its 16 bit MIIM registers thru its MDC and MDIO pins.</p>	Interface Signals	Type	Description	SPIQ	O	Not used. (tri-stated)	SCL	O	I2C clock	SDA	I/O	I2C data I/O	SPIS_N	lpu	Not used.	Interface Signals	Type	Description	SPIQ	O	Not used. (tri-stated)	SCL	I	I2C clock	SDA	I/O	I2C data I/O	SPIS_N	lpu	Not used.	Interface Signals	Type	Description	SPIQ	O	SPI Data Out	SCL	I	SPI clock	SDA	I	SPI Data In	SPIS_N	lpu	SPI chip select
Interface Signals	Type	Description																																														
SPIQ	O	Not used. (tri-stated)																																														
SCL	O	I2C clock																																														
SDA	I/O	I2C data I/O																																														
SPIS_N	lpu	Not used.																																														
Interface Signals	Type	Description																																														
SPIQ	O	Not used. (tri-stated)																																														
SCL	I	I2C clock																																														
SDA	I/O	I2C data I/O																																														
SPIS_N	lpu	Not used.																																														
Interface Signals	Type	Description																																														
SPIQ	O	SPI Data Out																																														
SCL	I	SPI clock																																														
SDA	I	SPI Data In																																														
SPIS_N	lpu	SPI chip select																																														
102	PV31	lpu	<p>Port 3 port based VLAN mask bits. Use to select which ports may transmit packets received on port 3.</p> <p>PV31 = 1, port 1 may transmit packets received on port 3. PV31 = 0, port 1 will not transmit any packets received on port 3.</p> <p>PV32 = 1, port 2 may transmit packets received on port 3. PV32 = 0, port 2 will not transmit any packets received on port 3.</p>																																													
103	PV32	lpu																																														
104	PV21	lpu	<p>Port 2 port based VLAN mask bits. Use to select which ports may transmit packets received on port 2.</p> <p>PV21 = 1, port 1 may transmit packets received on port 2. PV21 = 0, port 1 will not transmit any packets received on port 2.</p> <p>PV23 = 1, port 3 may transmit packets received on port 2. PV23 = 0, port 3 will not transmit any packets received on port 2.</p>																																													
105	PV23	lpu																																														
106	DGND	Gnd	Digital ground																																													

Pin #	Pin Name	Type	Description
107	VDDIO	Pwr	3.3V digital VDD
108	PV12	lpu	<p>Port 1 port based VLAN mask bits. Use to select which ports may transmit packets received on port 1.</p> <p>PV12 = 1, port 2 may transmit packets received on port 1. PV12 = 0, port 2 will not transmit any packets received on port 1.</p> <p>PV13 = 1, port 3 may transmit packets received on port 1. PV13 = 0, port 3 will not transmit any packets received on port 1.</p>
109	PV13	lpu	
110	P3_1PEN	lpd	<p>Enable 802.1p priority classification on port 3 ingress</p> <p>1 = enable 0 = disable</p> <p>Enable is from the receive perspective. If 802.1p processing is disabled or there is no tag, priority is determined by the P3_PP pin.</p>
111	P2_1PEN	lpd	<p>Enable 802.1p priority classification on port 2 ingress</p> <p>1 = enable 0 = disable</p> <p>Enable is from the receive perspective. If 802.1p processing is disabled or there is no tag, priority is determined by the P2_PP pin.</p>
112	P1_1PEN	lpd	<p>Enable 802.1p priority classification on port 1 ingress</p> <p>1 = enable 0 = disable</p> <p>Enable is from the receive perspective. If 802.1p processing is disabled or there is no tag, priority is determined by the P1_PP pin.</p>
113	P3_TXQ2	lpd	<p>Select transmit queue split on port 3</p> <p>1 = split 0 = no split</p> <p>The split sets up high and low priority queues. Packet priority classification is done on ingress ports, via port-based, 802.1p or TOS based scheme. The priority enabled queuing on port 3 is set by P3_TXQ2.</p>
114	P2_TXQ2	lpd	<p>Select transmit queue split on port 2</p> <p>1 = split 0 = no split</p> <p>The split sets up high and low priority queues. Packet priority classification is done on ingress ports, via port-based, 802.1p or TOS based scheme. The priority enabled queuing on port 2 is set by P2_TXQ2.</p>
115	P1_TXQ2	lpd	<p>Select transmit queue split on port 1</p> <p>1 = split 0 = no split</p> <p>The split sets up high and low priority queues. Packet priority classification is done on ingress ports, via port-based, 802.1p or TOS based scheme. The priority enabled queuing on port 1 is set by P1_TXQ2.</p>
116	P3_PP	lpd	Select port-based priority on port 3 ingress

Pin #	Pin Name	Type	Description
			<p>1 = high 0 = low <default> 802.1p and Diffserv, if applicable, will take precedence.</p>
117	P2_PP	lpd	<p>Select port-based priority on port 2 ingress 1 = high 0 = low <default> 802.1p and Diffserv, if applicable, will take precedence.</p>
118	P1_PP	lpd	<p>Select port-based priority on port 1 ingress 1 = high 0 = low <default> 802.1p and Diffserv, if applicable, will take precedence.</p>
119	P3_TAGINS	lpd	<p>Enable tag insertion on port 3 egress 1 = enable 0 = disable All packets transmitted from port 3 will have 802.1Q tag. Packets received with tag will be sent out intact. Packets received without tag will be tagged with ingress port's default tag.</p>
120	P2_TAGINS	lpd	<p>Enable tag insertion on port 2 egress 1 = enable 0 = disable All packets transmitted from port 2 will have 802.1Q tag. Packets received with tag will be sent out intact. Packets received without tag will be tagged with ingress port's default tag.</p>
121	P1_TAGINS	lpd	<p>Enable tag insertion on port 1 egress 1 = enable 0 = disable All packets transmitted from port 1 will have 802.1Q tag. Packets received with tag will be sent out intact. Packets received without tag will be tagged with ingress port's default tag.</p>
122	DGND	Gnd	Digital ground
123	VDDC	Pwr	1.8V digital VDD
124	P3_TAGRM	lpd	<p>Enable tag removal on port 3 egress 1 = enable 0 = disable All packets transmitted from port 3 will not have 802.1Q tag. Packets received with tag will be modified by removing 802.1Q tag. Packets received without tag will be sent out intact.</p>
125	P2_TAGRM	lpd	<p>Enable tag removal on port 2 egress 1 = enable 0 = disable All packets transmitted from port 2 will not have 802.1Q tag. Packets received with tag will be modified by removing 802.1Q tag. Packets received without tag will be sent out intact.</p>
126	P1_TAGRM	lpd	Enable tag removal on port 1 egress

Pin #	Pin Name	Type	Description
			1 = enable 0 = disable All packets transmitted from port 1 will not have 802.1Q tag. Packets received with tag will be modified by removing 802.1Q tag. Packets received without tag will be sent out intact.
127	TESTEN	lpd	Scan Test Enable For normal operation, pull down this pin to ground
128	SCANEN	lpd	Scan Test Scan Mux Enable For normal operation, pull down this pin to ground

Note:

Pwr = power supply;

Gnd = ground;

I = input;

O = output;

I/O = bi-directional

Ipu = input w/ internal pull up;

Ipd = input w/ internal pull down;

Ipu/O = input w/ internal pull up during
reset, output pin otherwise;Ipd/O = input w/ internal pull down during
reset, output pin otherwise;

PD = strap pull down;

PU = strap pull up;

Otri = output tri-stated;

Opu = Output with internal pull-up;

Opd = Output with internal pull-down

2 Functional Description

2.1 Overview

The KS8993F is a single-chip Fast Ethernet media converter. It contains two 10/100 physical layer transceivers, three MAC (Media Access Control) units, layer-2 managed switch, and frame buffer. On the media side, the KS8993F supports IEEE 802.3 10BASE-T, 100BASE-TX on ports 1 and 2, and 100BASE-FX on port 1.

The KS8993F implements the unique OAM sub-layer, which resides between RS and PCS layer in the IEEE 802.3 standard. The KS8993F sends and receives an OAM frame that has a fixed length of 96 bits. This special frame is used for the transmission of OAM information between center MC and terminal MC.

The KS8993F has the flexibility to reside in an unmanaged or managed design. An unmanaged design is achieved through I/O strapping or EEPROM programming at system reset time. In a managed design, a host processor has complete control of the KS8993F via the SMI, MIIM, SPI or I²C interface.

The KS8993F supports advanced Quality Of Service, port mirroring, rate limiting, broadcast storm protection, and management via SNMP.

The KS8993FL is the single supply version with all the identical rich features of the KS8993F. In the KS8993FL version, pin number 22 provides 1.8V output power to the KS8993FL's VDDC, VDDA and VDDAP power pins. Refer to the pin description of pin number 22 in section 1.2, Pin Description and I/O Assignment, for more details.

Physical signal transmission and reception are enhanced through the use of patented analog circuitry that makes the design more efficient, and allows for lowest power consumption and smaller chip die size.

2.2 Media Converter Function

The KS8993F is the industry's first single-chip Fast Ethernet media converter that conforms to the TS-1000 spec. The TS-1000 spec. has been standardized by the TELECOMMUNICATION TECHNOLOGY COMMITTEE (TTC) of Japan in May 2002 and can be purchased from TTC. Some key TS-1000 features include:

- Private point-to-point communication between two TS-1000 compliant devices
- 96 bits (12 bytes) frames for the transmission of OAM information between center MC and terminal MC
- Transmission of MC status between center MC and terminal MC
- Automatic generation of OAM frame to inform MC link partner of local MC's status change
- Transmission of vendor code and model number information between center MC and terminal MC for device identification
- Inquisition of terminal MC status by center MC
- Remote loop back for diagnostic by center MC

2.2.1 OAM (Operations, Administration, and Management) Frame Format

Bit	Command	Description
F0-F7	Preamble	1010 1010
C0	Conservation Delimiter	0
C1	Direction Delimiter	0: Upstream (from terminal MC to center MC) 1: Downstream (from center MC to terminal MC)
C2-C3	Configuration Delimiter	10: request 11:reponse 01: indication 00:reserved
C4-C7	Version	0000
C8-C15	Control signal	1000 0000: Start loop back test 0000 0000: Stop loop back test 0100 0000: Notify status
S0	Power	0: normal operation 1: power down
S1	Optical	0: normal 1:abnormal
S2	UTP link	0: link up 1: link down
S3	MC	0: normal 1:brake
S4	Way for information	0: use conservation frame 1: use FEFI
S5	Loop mode	0: normal operation 1: in loop mode
S6	Terminal MC Link option	0: Center side MC have to set always "0" 1: Terminal side MC have to set always "1"
S7	Terminal MC Link Speed1	This bit must be set "0"
S8	Terminal MC Link Speed2	0: 10Mbps 1: 100Mbps These bits have to be set "0", if S2 is "1" (Center side MC have to set always "0")
S9	Terminal MC Link Duplex	0: Half Duplex 1: Full Duplex This bit have to be set "0", if S2 is "1" (Center side MC have to set always "0")
S10	Terminal MC Auto-Negotiation capability	0: Not Support Auto-Negotiation 1: Support Auto-Negotiation (Center side MC have to set always "0")
S11	Multiple link partner	0: one link partner on UTP side 1: multiple link partner on UTP side
S12 - S15	Reserve	All bits must be set "0"
M0-M23	Vendor code	
M24-M47	Model number	
E0-E7	FCS	Create FCS at this sub-layer (C0-M47)

2.2.2 MC (Media Converter) Mode

MC (Media Converter) mode is selected and configured using hardware pins: MCCS and MCHS.

Terminal MC mode without port 3 support is enabled when MCCS=0 and MCHS=1. In this mode, port 1 is 100BASE-FX, port 2 is 10BASE-TX or 100BASE-TX and port 3 is disabled. Terminal MC function is enabled, and the OAM sub-layer responds to the center MC with OAM frames, such as condition inform reply, loop mode start reply, and loop mode stop reply.

Terminal MC mode with port 3 support is enabled when MCCS=1 and MCHS=1. In this mode, port 1 is 100BASE-FX, port 2 is 10BASE-T or 100BASE-TX and port 3 supports MII or SNI interface. Terminal MC function is enabled, and the OAM sub-layer responds to the center MC with OAM frames, such as condition inform reply, loop mode start reply, and loop mode stop reply.

Center MC mode with port 3 support is enabled when MCCS=1 and MCHS=0. In this mode, port 1 is 100BASE-FX, port 2 is 10BASE-T or 100BASE-TX and port 3 supports MII or SNI interface. Center MC function is enabled, and the OAM sub-layer generates and sends OAM frames, such as condition inform request, loop mode start request and loop mode stop request to the terminal MC.

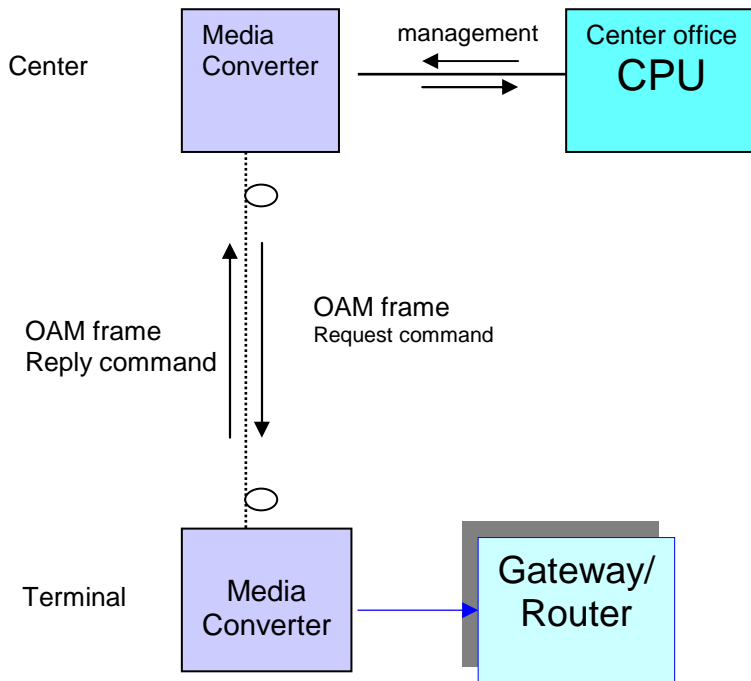

2.2.3 MC Loop Back Function

MC loop back operation is initiated and enabled by the center MC. The terminal MC provides the loop back path to return the loop back packet back to the center MC. In terminal MC mode, the KS8993F provides the following loop back path:

- Receive loop back packet from center MC at RXP1/RXM1 input pins of port 1 (fiber).
- Turn around loop back packet at MAC of port 2 (copper).
- Transmit loop back packet back to center MC from TXP1/TXM1 output pins of port 1 (fiber).

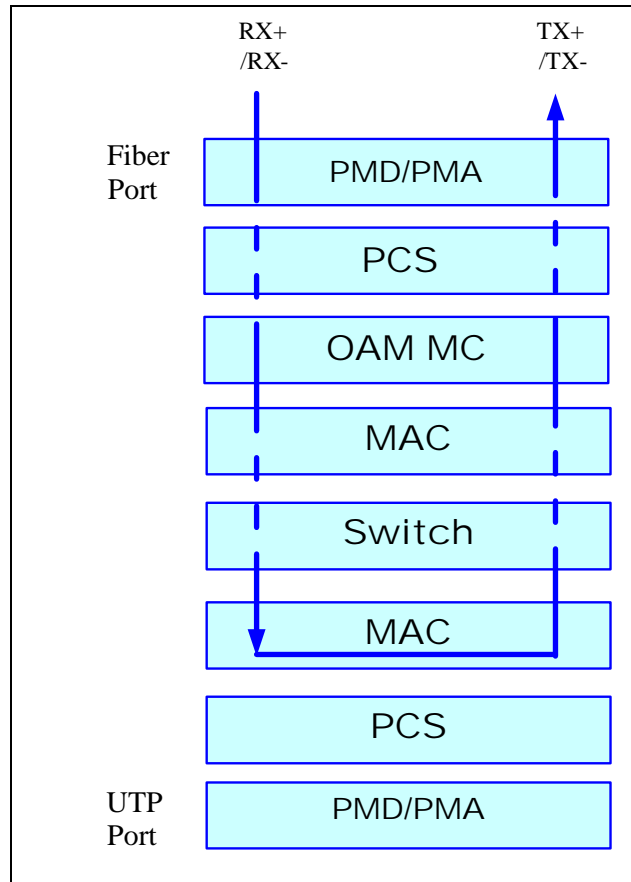

2.2.4 Registers for Media Converter Functions

The KS8993F provides 32 dedicated registers (0x40 to 0x5F) for MC communication between center MC and terminal MC. Some MC register functions include:

- PHY address & configuration
- Loop back counters for CRC error, timeout, good packet
- Remote commands
- Counters for valid MC packet transmitted and received
- MC - status, vendor code, and model number
- Link Partner - status, vendor code, and model number

2.2.5 Unique I/O Feature Definition

Pin	Signal Name	Type	Description
#27	HWPOVR	Input	<p>Hardware pin strapping to override the EEPROM value after reset</p> <p>When HWPOVR = 0, the reset sequence for KS8993F are:</p> <ul style="list-style-type: none"> • Reads HW pin strapping configuration after reset. • Reads EEPROM configuration for all registers. <p>When HWPOVR = 1, the reset sequence for KS8993F are:</p> <ul style="list-style-type: none"> • Reads HW pin strapping configuration after reset. • Reads EEPROM configuration for all registers, except for port 2 (auto negotiation, speed, duplex) and Missing Link. <p>When HWPOVR = 1 during normal switch operation:</p> <ol style="list-style-type: none"> 1. Port 2 (auto negotiation, speed, duplex) can be updated via pins P2ANEN, P2SPD and P2DPX, respectively. These three pins are polled by the KS8993F.

2.2.6 Port 1 LED Indicator Definition

	LEDSEL1 = 0		LEDSEL1 = 1	
	LEDSEL0=0	LEDSEL0=1	LEDSEL0=0	LEDSEL0=1
P1LED3	Tri-state, Pull-Down	Tri-state, Pull-Down	Activity	---
P1LED2	Link/Activity	100BASE-TX Link/Activity	Link	---
P1LED1	Full Duplex/ Collision	10BASE-T Link/Activity	Full Duplex/ Collision	---
P1LED0	Speed	Full Duplex	Speed	---

2.2.7 Port 2 LED Indicator Definition

	LEDSEL1 = 0		LEDSEL1 = 1	
	LEDSEL0=0	LEDSEL0=1	LEDSEL0=0	LEDSEL0=1
P2LED3	Tri-state, Pull-Down	Tri-state, Pull-Down	Activity	---
P2LED2	Link/Activity	100BASE-TX Link/Activity	Link	---
P2LED1	Full Duplex/ Collision	10BASE-T Link/Activity	Full Duplex/ Collision	---
P2LED0	Speed	Full Duplex	Speed	---

2.3 Physical Transceiver

2.3.1 100BASE-TX Transmit

The 100BASE-TX transmit function performs parallel to serial conversion, 4B/5B coding, scrambling, NRZ to NRZI conversion, MLT3 encoding and transmission. The circuit starts with a parallel to serial conversion, which converts the MII data from the MAC into a 125 MHz serial bit stream. The data and control stream is then converted into 4B/5B coding followed by a scrambler. The serialized data is further converted from NRZ to NRZI format, and then transmitted in MLT3 current output. The output current is set by an external 1% 3.01 K Ω resistor for the 1:1 transformer ratio. It has a typical rise/fall time of 4 ns and complies with the ANSI TP-PMD standard regarding amplitude balance, overshoot and timing jitter. The wave-shaped 10BASE-T output is also incorporated into the 100BASE-TX transmitter.

2.3.2 100BASE-TX Receive

The 100BASE-TX receiver function performs adaptive equalization, DC restoration, MLT3 to NRZI conversion, data and clock recovery, NRZI to NRZ conversion, de-scrambling, 4B/5B decoding and serial to parallel conversion. The receiving side starts with the equalization filter to compensate for inter-symbol interference (ISI) over the twisted pair cable. Since the amplitude loss and phase distortion is a function of the length of the cable, the equalizer has to adjust its characteristics to optimize the performance. In this design, the variable equalizer will make an initial estimation based on comparisons of incoming signal strength against some known cable characteristics, then it tunes itself for optimization. This is an ongoing process and can self adjust against environmental changes such as temperature variations.

The equalized signal then goes through a DC restoration and data conversion block. The DC restoration circuit is used to compensate for the effect of base line wander and improve the dynamic range. The differential data conversion circuit converts the MLT3 format back to NRZI. The slicing threshold is also adaptive.

The clock recovery circuit extracts the 125 MHz clock from the edges of the NRZI signal. This recovered clock is then used to convert the NRZI signal into the NRZ format. The signal is then sent through the de-scrambler followed by the 4B/5B decoder. Finally, the NRZ serial data is converted to the MII format and provided as the input data to the MAC.

2.3.3 PLL Clock Synthesizer

The KS8993F generates 125 MHz, 31.25 MHz, 25 MHz and 10 MHz clocks for system timing. Internal clocks are generated from an external 25 MHz crystal or oscillator.

2.3.4 Scrambler/De-scrambler (100BASE-TX only)

The purpose of the scrambler is to spread the power spectrum of the signal in order to reduce EMI and baseline wander. Transmitted data is scrambled through the use of an 11-bit wide linear feedback shift register (LFSR). The scrambler can generate a 2047-bit non-repetitive sequence. The receiver will then de-scramble the incoming data stream with the same sequence at the transmitter.

2.3.5 100BASE-FX Operation and Signal Detection

100BASE-FX operation is very similar to 100BASE-TX operation with the differences being that the scrambler/de-scrambler and MLT3 encoder/decoder are bypassed on transmission and reception. In this mode, the auto negotiation feature is bypassed since there is no standard that supports fiber auto negotiation, and the auto MDI/MDI-X feature is also disabled.

For 100BASE-FX operation, the KS8993F FXSD1 (fiber signal detect) input pin is usually connected to the fiber transceiver SD (signal detect) output pin. 100BASE-FX mode is activated when FXSD1 is greater than 1V. When FXSD1 is between 1V and 1.8V, no fiber signal is detected and a Far-End Fault is generated if the feature is enabled. Alternatively, FXSD1 can be tied high to force 100BASE-FX mode if the Far-End Fault feature is not used. When FXSD1 is greater than 2.2V, the fiber signal is detected.

100BASE-FX signal detection is summarized in the following table.

Table 1: FX and TX Mode Selection

FXSD1 (pin 44)	Condition
Less than 0.2V	TX mode
Greater than 1V, but less than 1.8V	FX mode No signal detected; Far-End Fault generated (if enabled)
Greater than 2.2V	FX mode Signal detected

To ensure proper operation, a resistive voltage divider is recommended to adjust the fiber transceiver SD output voltage swing to match the KS8993F FXSD1 input voltage threshold. Refer to KS8993F schematic for recommended fiber transceiver connections.

2.3.6 100BASE-FX Far-End Fault (FEF)

Far-End Fault (FEF) occurs when the signal detection is logically false on the receive side of the fiber transceiver. The KS8993F detects a FEF when its FXSD1 input is between 1.0V and 1.8V. When a FEF occurs, the transmission side signals the link partner by sending 84 ones followed by 1 zero in the idle period between frames.

Upon receiving a FEF, the link will go down (even when the fiber signal is detected) to indicate a fault condition. The transmitting side is not affected when a FEF is received, and will continue to send out its normal transmit pattern from the MAC.

By default, FEF is enabled. FEF can be disabled through register setting.

2.3.7 10BASE-T Transmit and Receive

The output 10BASE-T driver is incorporated into the 100BASE-TX driver to allow transmission with the same magnetic. They are internally wave-shaped and pre-emphasized into outputs with a typical 2.3 V amplitude. The harmonic contents are at least 27 dB below the fundamental when driven by an all-ones Manchester-encoded signal.

On the receive side, input buffer and level detecting squelch circuits are employed. A differential input receiver circuit and a PLL perform the decoding function. The Manchester-encoded data stream is separated into clock signal and NRZ data. A squelch circuit rejects signals with levels less than 400 mV or with short pulse widths in order to prevent noises at the RXP or RXM input from falsely triggering the decoder. When the input exceeds the squelch limit, the PLL locks onto the incoming signal and the KS8993F decodes a data frame. The receiver clock is maintained active during idle periods in between data reception.

2.3.8 Power Management

The KS8993F features a per-port power down mode. To save power, a port that is not being used can be powered down through the port control registers, or MIIM control registers. In addition, there is a full chip power down mode. When activated, the entire chip will be shut down.

2.3.9 Auto MDI/MDI-X Crossover

The KS8993F supports auto MDI/MDI-X crossover. This facilitates the use of either a straight connection CAT-5 cable or a crossover CAT-5 cable. The auto-sense function will detect remote transmit and receive pairs, and correctly assign the transmit and receive pairs from the KS8993F device. This feature can be extremely useful when the end users are unaware of cable type differences, and can also save on an additional uplink configuration connection.

By default, auto MDI/MDI-X is enabled. It can be disabled through the port control registers.

Based on the IEEE 802.3 standard, the MDI and MDI-X definitions are as follows:

Table 2: MDI/MDI-X Pin Definition

<u>MDI</u>		<u>MDI-X</u>	
RJ45 pins	Signals	RJ45 pins	Signals
1	TD+	1	RD+
2	TD-	2	RD-
3	RD+	3	TD+
6	RD-	6	TD-

A "Straight Cable" connects a MDI device to a MDI-X device, or a MDI-X device to a MDI device. The following diagram depicts a typical "Straight Cable" connection between a NIC card (MDI) and a switch, or hub (MDI-X).

Figure 1: Typical Straight Cable Connection

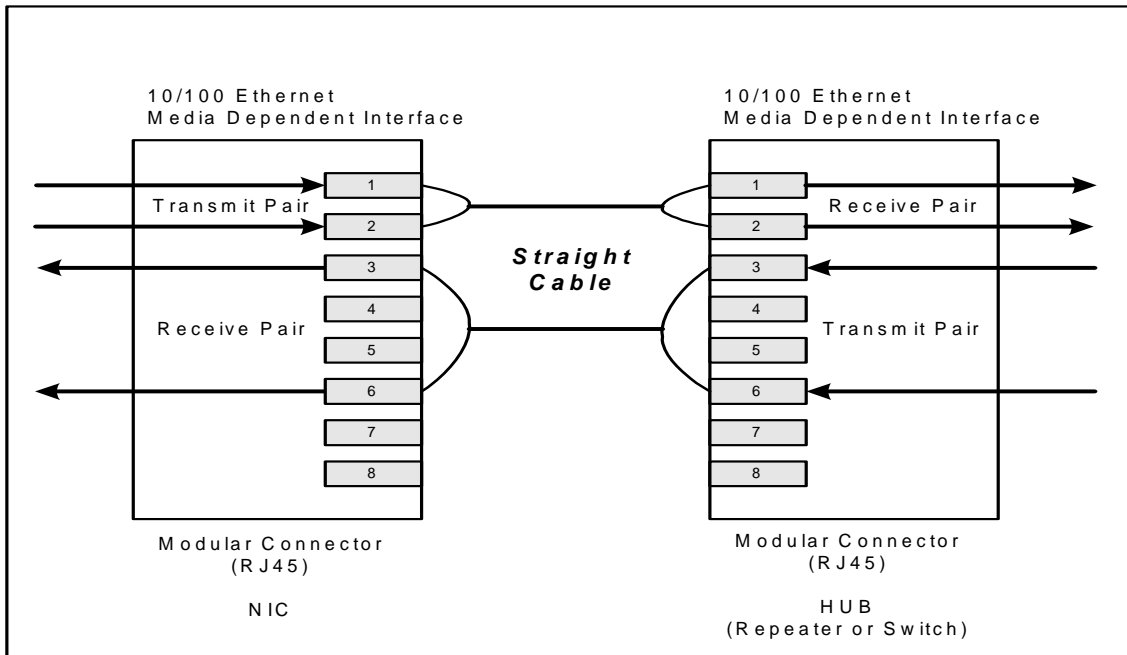

A "Crossover Cable" connects a MDI device to another MDI device, or a MDI-X device to another MDI-X device. The following diagram depicts a typical "Crossover Cable" connection between two switches, or hubs (two MDI-X devices).

Figure 2: Typical Crossover Cable Connection

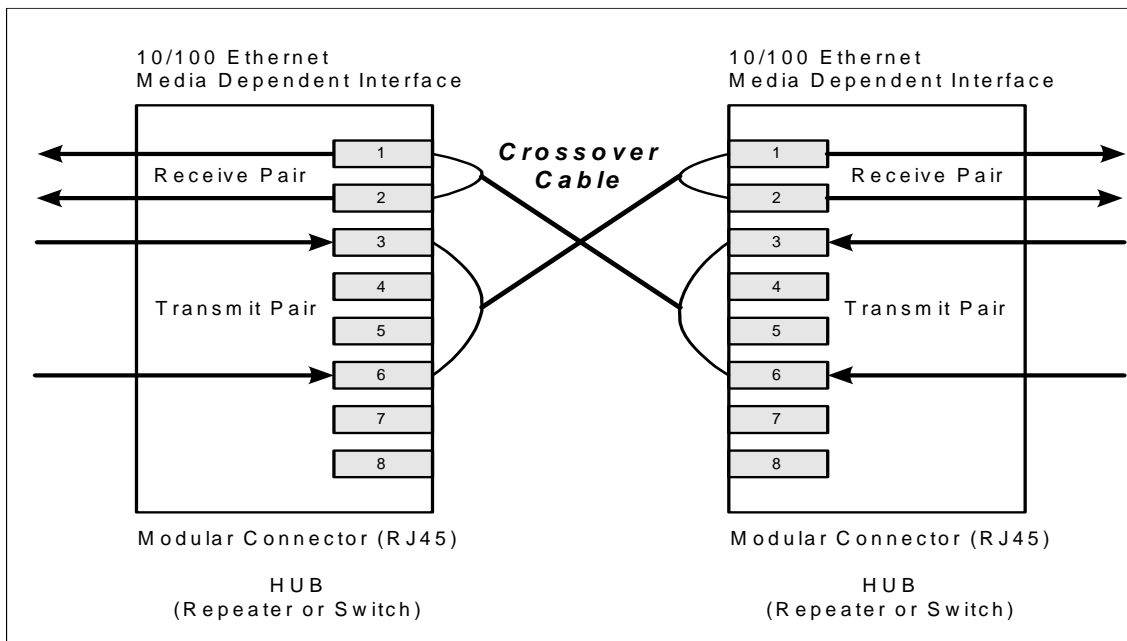

2.3.10 Auto Negotiation

The KS8993F conforms to the auto negotiation protocol as described by the 802.3 committee. Auto negotiation allows UTP (Unshielded Twisted Pair) link partners to select the best common mode of operation. In auto negotiation the link partners advertise capabilities across the link to each other. If auto negotiation is not supported or the link partner to the KS8993F is forced to bypass auto negotiation, then the mode is set by observing the signal at the receiver. This is known as parallel mode because while the transmitter is sending auto negotiation advertisements, the receiver is listening for advertisements or a fixed signal protocol.

The link set up is depicted in the following flow diagram.

Figure 3: Auto Negotiation and Parallel Detection

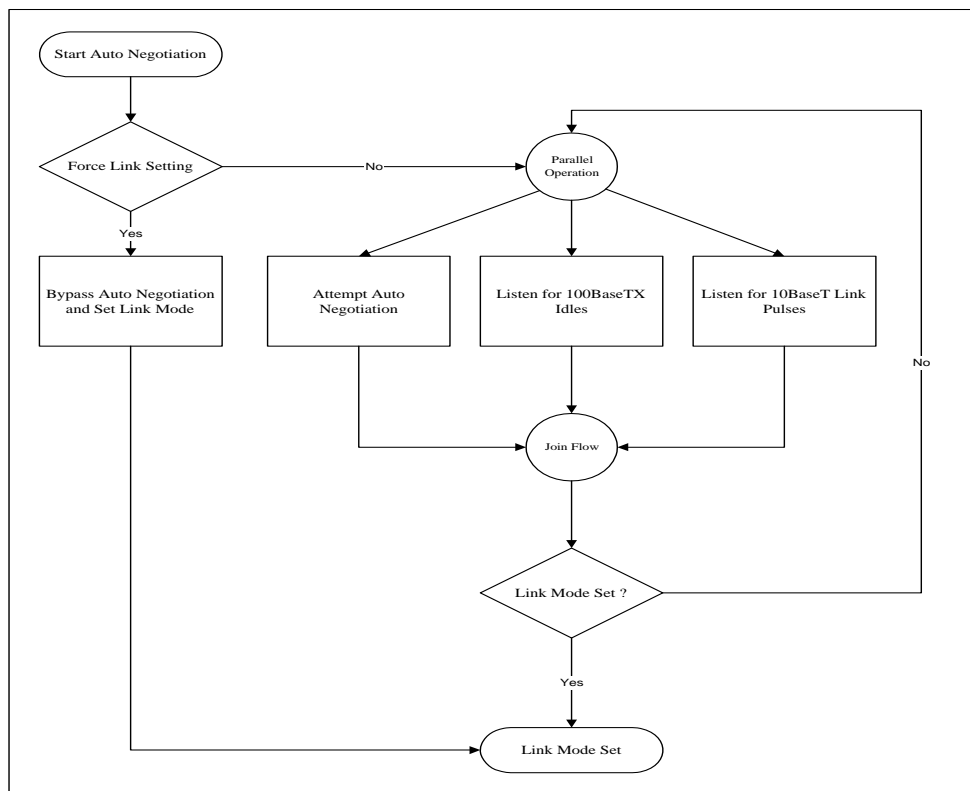

2.4 MAC and Switch Function

2.4.1 Address Look Up

The internal look up table stores MAC addresses and their associated information. It contains a 1K uni-cast address table plus switching information. The KS8993F is guaranteed to learn 1K addresses and distinguishes itself from hash-based look up tables, which depending on the operating environment and probabilities, may not guarantee the absolute number of addresses it can learn.

2.4.2 Learning

The internal look up engine will update its table with a new entry if the following conditions are met:

1. The received packet's Source Address (SA) does not exist in the look up table.
2. The received packet is good, has no receiving errors, and is of legal length.

The look up engine will insert the qualified Source Address into the table, along with the port number and time stamp. If the table is full, the last entry of the table will be deleted to make room for the new entry.

2.4.3 Migration

The internal look up engine also monitors whether a station has moved. If so, it will update the table accordingly. Migration happens when the following conditions are met:

1. The received packet's Source Address (SA) is in the table but the associated source port information is different.
2. The received packet is good, has no receiving errors, and is of legal length.

The look up engine will update the existing record in the table with the new source port information.

2.4.4 Aging

The look up engine will update the time stamp information of a record whenever the corresponding Source Address appears. The time stamp is used in the aging process. If a record is not updated for a period of time, the look up engine will remove the record from the table. The look up engine constantly performs the aging process and will continuously remove aging records. The aging period is 200 seconds. This feature can be enabled or disabled through Global Register 3 (0x03).

2.4.5 Forwarding

The KS8993F will forward packets using an algorithm that is depicted in the following flowcharts. Figure 4 shows stage one of the forwarding algorithm where the search engine looks up the VLAN ID, static table, and dynamic table for the destination address, and comes up with "port to forward 1" (PTF1). PTF1 is then further modified by Spanning Tree, Port Mirroring and Port VLAN processes to come up with "port to forward 2" (PTF2) as shown in Figure 5. PTF2 is where the packet will be sent.

Figure 4: Destination Address look up flowchart, stage 1

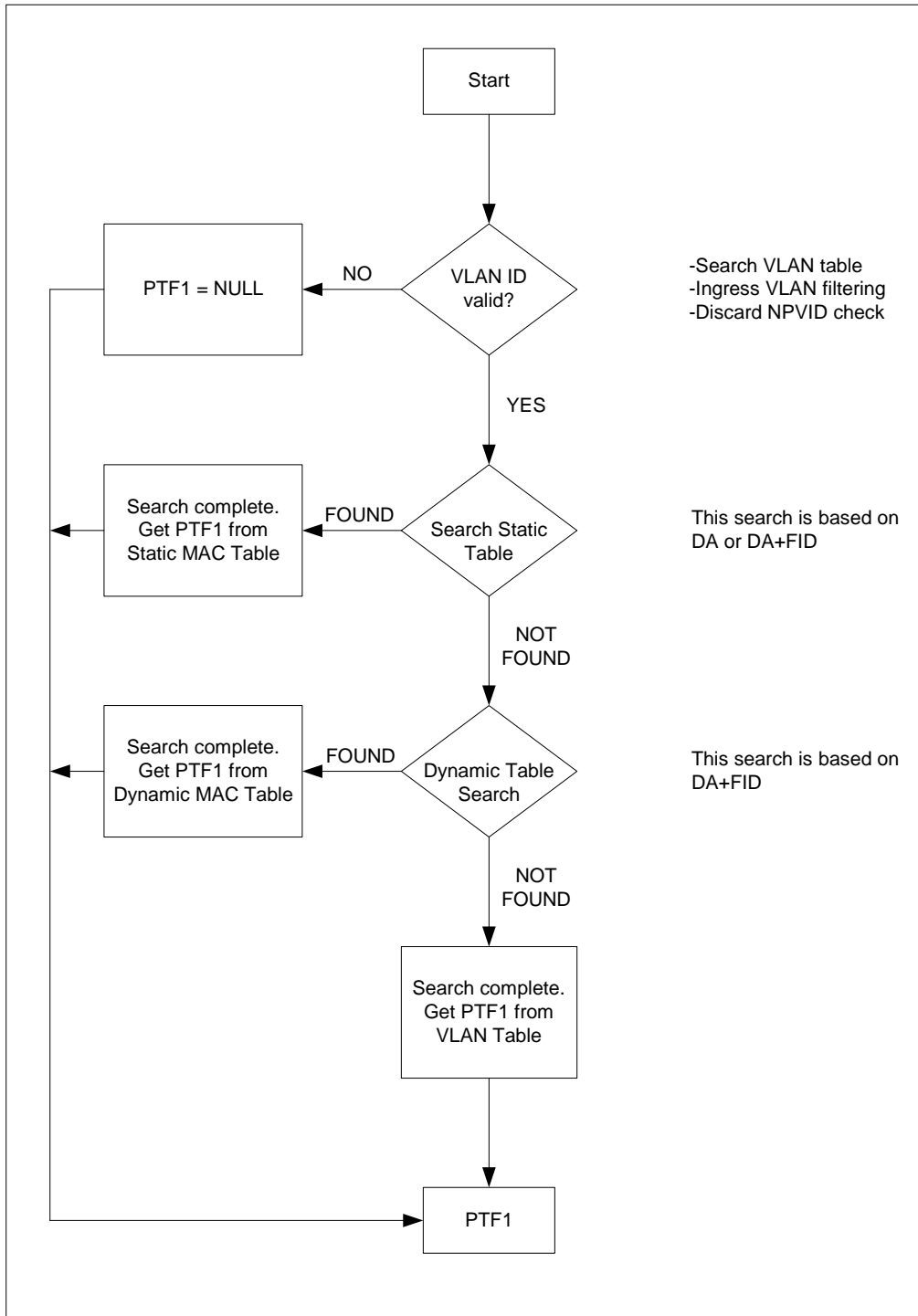
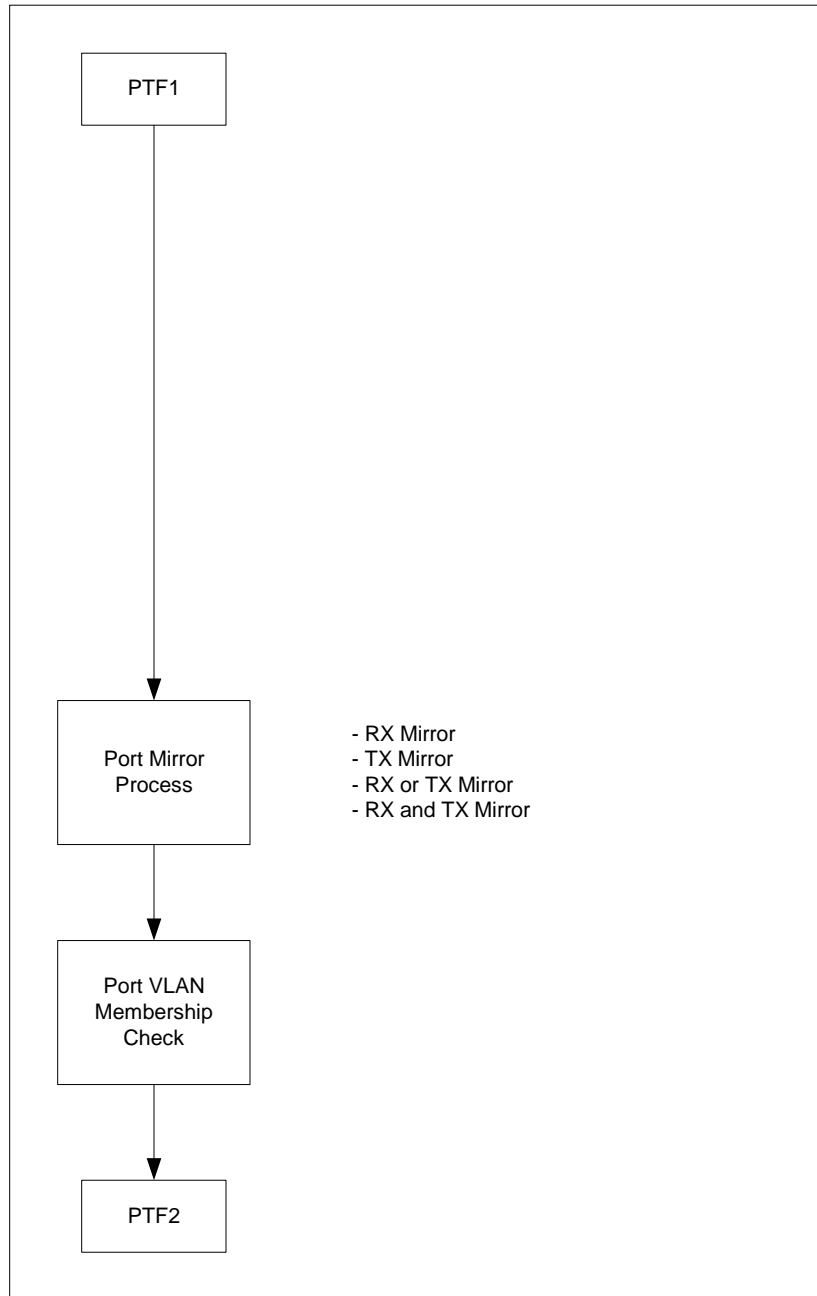

Figure 5: Destination Address resolution flowchart, stage 2



The KS8993F will not forward the following packets:

1. Error packets. These include framing errors, FCS errors, alignment errors, and illegal size packet errors.
2. 802.3x pause frames. The KS8993F will intercept these packets and perform the appropriate actions.
3. "Local" packets. Based on Destination Address (DA) look up, if the destination port from the look up table matches the port where the packet was from, the packet is defined as "local".

2.4.6 Switching Engine

The KS8993F features a high-performance switching engine to move data to and from the MAC using built-in frame buffers. It operates in store and forward mode, while the efficient switching mechanism reduces overall latency.

The KS8993F has a 32KB internal frame buffer. This resource is shared between all three ports. The buffer sharing mode can be programmed through Global Register 2 (0x02). In one mode, ports are allowed to use any free buffers in the buffer pool. In the second mode, each port is only allowed to use 1/3 of the total buffer pool. There are a total of 250 buffers available. Each buffer is 128 bytes in size.

2.4.7 MAC operation

The KS8993F strictly abides by IEEE 802.3 standards to maximize compatibility.

Inter Packet Gap (IPG)

If a frame is successfully transmitted, the 96-bit time IPG is measured between the two consecutive MTXEN. If the current packet is experiencing collision, the 96-bit time IPG is measured from MCRS and the next MTXEN.

2.4.8 Back-off Algorithm

The KS8993F implements the IEEE Standard 802.3 binary exponential back-off algorithm, and optional "aggressive mode" back-off. After 16 collisions, the packet will be optionally dropped depending on the chip configuration in Global Register 3 (0x03).

2.4.9 Late Collision

If a transmit packet experiences collisions after 512 bit times of the transmission, the packet will be dropped.

2.4.10 Illegal Frames

The KS8993F discards frames less than 64 bytes long and can be programmed to accept frames up to 1536 bytes long in Global Register 4 (0x04). For special applications, the KS8993F can also be programmed to accept frames up to 1916 bytes long in the same global register. Since the KS8993F supports VLAN tags, the maximum sizing is adjusted when these tags are present.

2.4.11 Flow Control

The KS8993F supports standard 802.3x flow control frames on both transmit and receive sides.

On the receive side, if the KS8993F receives a pause control frame, the KS8993F will not transmit the next normal frame until the timer, specified in the pause control frame, expires. If another pause frame is received before the current timer expires, the timer will be updated with the new value from the second pause frame. During this period (being flow controlled), only flow control packets from the KS8993F will be transmitted.

On the transmit side, the KS8993F has intelligent and efficient means to determine when to invoke flow control. The flow control is based on the availability of system resources, including available buffers, available transmit queues and available receive queues.

The KS8993F will flow control a port, which just received a packet, if the destination port resource is being used up. The KS8993F will issue a flow control frame (XOFF), containing the maximum pause time defined in IEEE standard 802.3x. Once the resource is freed up, the KS8993F will send out the other flow control frame (XON) with zero pause time to turn off the flow control (turn on transmission to the port). A hysteresis feature is provided to prevent the flow control mechanism from being activated and deactivated too many times.

The KS8993F will flow control all ports if the receive queue becomes full.

2.4.12 Half Duplex Back Pressure

A half-duplex back-pressure option (Note: not in IEEE 802.3 standards) is also provided. The activation and deactivation conditions are the same as the above in full duplex mode. If back-pressure is required, the KS8993F will send preambles to defer the other stations' transmission (carrier sense deference). To avoid jabber and excessive deference defined in 802.3 standard, after a certain time it will discontinue the carrier sense but it will raise the carrier sense quickly. This short silent time (no carrier sense) is to prevent other stations from sending out packets and keeps other stations in carrier sense deferred state. If the port has packets to send during a back-pressure situation, the carrier sense type back-pressure will be interrupted and those packets will be transmitted instead. If there are no more packets to send, carrier sense type back-pressure will be active again until switch resources free up. If a collision occurs, the binary exponential back-off algorithm is skipped and carrier sense is generated immediately, reducing the chance of further colliding and maintaining carrier sense to prevent reception of packets.

To ensure no packet loss in 10 BASE-T or 100 BASE-TX half duplex modes, the following should be enabled:

1. Aggressive back off (set Global Register 3 (0x03), bit 0 to '1', or pull high SMAC (pin 69))
2. No excessive collision drop (set Global Register 4 (0x04), bit 3 to '1', or pull high SMAC (pin 69))

These bits are not set as defaults because the settings are not part of the IEEE standard.

2.4.13 Broadcast Storm Protection

The KS8993F has an intelligent option to protect the switch system from receiving too many broadcast packets. Broadcast packets will be forwarded to all ports except the source port, and thus use too many switch resources (bandwidth and available space in transmit queues). The KS8993F has the option to include "multicast packets" for storm control. The broadcast storm rate parameters are programmed globally, and can be enabled or disabled on a per port basis. The rate is based on a 67ms interval for 100BT and a 500 ms interval for 10BT. At the beginning of each interval, the counter is cleared to zero, and the rate limit mechanism starts to count the number of bytes during the interval. The rate definition is described in Global Registers 6 (0x06) and 7 (0x07). The default setting for registers 6 and 7 is 0x63, which is 99 decimal. This is equal to a rate of 1 %, calculated as follows:

$$148,800 \text{ frames/sec} * 67 \text{ ms/interval} * 1\% = 99 \text{ frames/interval (approx.)} = 0x63h$$

This means the KS8993F accepts only 1% of broadcast data and filters out 99%.

2.5 MII Interface Operation

The MII (Media Independent Interface) is specified by the IEEE 802.3 committee and provides a common interface between physical layer and MAC layer devices. The MII Interface provided by the KS8993F is connected to the device's third MAC. The interface contains two distinct groups of signals: one for transmission and the other for reception. The following table describes the signals used in the MII interface.

Table 3: MII Signals

KS8993F PHY mode connections		Pin Description	KS8993F MAC mode connections	
External MAC signals	KS8993F PHY signals		External PHY signals	KS8993F MAC signals
MTXEN	SMTXEN	Transmit enable	MTXEN	SMRXDV
MTXER	SMTXER	Transmit error	MTXER	(not used)
MTXD3	SMTXD[3]	Transmit data bit 3	MTXD3	SMRXD[3]
MTXD2	SMTXD[2]	Transmit data bit 2	MTXD2	SMRXD[2]
MTXD1	SMTXD[1]	Transmit data bit 1	MTXD1	SMRXD[1]
MTXD0	SMTXD[0]	Transmit data bit 0	MTXD0	SMRXD[0]
MTXC	SMTXC	Transmit clock	MTXC	SMRXC
MCOL	SCOL	Collision detection	MCOL	SCOL
MCRS	SCRS	Carrier sense	MCRS	SCRS
MRXDV	SMRXDV	Receive data valid	MRXDV	SMTXEN
MRXER	(not used)	Receive error	MRXER	SMTXER
MRXD3	SMRXD[3]	Receive data bit 3	MRXD3	SMTXD[3]
MRXD2	SMRXD[2]	Receive data bit 2	MRXD2	SMTXD[2]
MRXD1	SMRXD[1]	Receive data bit 1	MRXD1	SMTXD[1]
MRXD0	SMRXD[0]	Receive data bit 0	MRXD0	SMTXD[0]
MRXC	SMRXC	Receive clock	MRXC	SMTXC

The MII interface operates in either PHY mode or MAC mode. The interface is a nibble wide data interface, and therefore runs at ¼ the network bit rate (not encoded). Additional signals on the transmit side indicate when data is valid or when an error occurs during transmission. Likewise, the receive side has indicators that convey when the data is valid and without physical layer errors. For half duplex operation, there is a signal that indicates a collision has occurred during transmission.

Note that the signal MRXER is not provided on the interface for PHY mode operation and the signal MTXER is not provided on the interface for MAC mode operation. Normally, MRXER would indicate a receive error coming from the physical layer device. MTXER would indicate a transmit error from the MAC device. These signals are not appropriate for this configuration. For PHY mode operation, if the device interfacing with the KS8993F has an MRXER pin, it should be tied low. For MAC mode operation, if the device interfacing with the KS8993F has an MTXER pin, it should be tied low.

2.6 SNI (7-wire) Interface Operation

The SNI (Serial Network Interface) or 7-wire is compatible with some controllers used for network layer protocol processing. In SNI mode, the KS8993F acts like a PHY and the external controller functions as the MAC. The KS8993F can interface directly with external controllers using the 7-wire interface. These signals are divided into two groups, one for transmission and the other for reception. The signals involved are described in the following table.

Table 4: SNI (7-wire) Signals

Pin Description	SNI signals	KS8993F signals
-----------------	-------------	-----------------

Transmit enable	TXEN	SMTXEN
Serial transmit data	TXD	SMTXD[0]
Transmit clock	TXC	SMTXC
Collision detection	COL	SCOL
Carrier sense	CRS	SMRXDV
Serial receive data	RXD	SMRXD[0]
Receive clock	RXC	SMRXC

The SNI interface is a bit wide data interface and therefore runs at the network bit rate (not encoded). An additional signal on the transmit side indicates when data is valid. Similarly, the receive side has an indicator that conveys when the data is valid.

For half duplex operation, the KS8993F SCOL signal is used to indicate that a collision has occurred during transmission.

2.7 MII Management Interface (MIIM)

The KS8993F supports the IEEE 802.3 MII Management Interface, also known as the Management Data Input / Output (MDIO) Interface. This interface allows upper-layer devices to monitor and control the states of the KS8993F. An external device with MDC/MDIO capability can be used to read the PHY status or configure the PHY settings. Further details on the MIIM interface can be found in section 22.2.4.5 of the IEEE 802.3 specification.

The MIIM interface consists of the following:

- ❑ A physical connection that incorporates the data line (MDIO) and the clock line (MDC).
- ❑ A specific protocol that operates across the aforementioned physical connection that allows an external controller to communicate with the KS8993F device.
- ❑ Access to a set of six 16-bits registers, consisting of standard MIIM registers [0:5].

The following table depicts the MII Management Interface frame format.

Table 5: MII Management Interface frame format

	Preamble	Start of Frame	Read/Write OP Code	PHY Address Bits [4:0]	REG Address Bits [4:0]	TA	Data Bits [15:0]	Idle
Read	32 1's	01	10	xx0AA	RRRRR	Z0	DDDDDDDD_DDDDDDDD	Z
Write	32 1's	01	01	xx0AA	RRRRR	10	DDDDDDDD_DDDDDDDD	Z

For the KS8993F, MIIM register access is selected when bit 2 of the PHY address is set to '0'. PHY address bits [4:3] are not defined for MIIM register access, and hence can be set to either 0's or 1's in read/write operation.

2.8 Serial Management Interface (SMI)

The Serial Management Interface is the KS8993F non-standard MIIM interface that provides access to all KS8993F configuration registers. This interface allows an external device to completely monitor and control the states of the KS8993F.

The SMI interface consists of the following:

- ❑ A physical connection that incorporates the data line (MDIO) and the clock line (MDC).
- ❑ A specific protocol that operates across the aforementioned physical connection that allows an external controller to communicate with the KS8993F device.
- ❑ Access to all KS8993F configuration registers. Registers access includes the Global, Port and Advanced Control Registers 0-127 (0x00 – 0x7F), and indirect access to the standard MIIM registers [0:5].

The following table depicts the Serial Management Interface frame format.

Table 6: Serial Management Interface (SMI) frame format

	Preamble	Start of Frame	Read/Write OP Code	PHY Address Bits [4:0]	REG Address Bits [4:0]	TA	Data Bits [15:0]	Idle
Read	32 1's	01	10	RR1xx	RRRRR	Z0	0000_0000_DDDD_DDDD	Z
Write	32 1's	01	01	RR1xx	RRRRR	10	xxxx_xxxx_DDDD_DDDD	Z

For the KS8993F, SMI register access is selected when bit 2 of the PHY address is set to '1'. PHY address bits [1:0] are not defined for SMI register access, and hence can be set to either 0's or 1's in read/write operation.

To access the KS8993F registers 0-127 (0x00 – 0x7F), the following applies:

- ❑ PHYAD[4:3] and REGAD[4:0] are concatenated to form the 7-bits address. i.e., {PHYAD[4:3], REGAD[4:0]} = bits [6:0] of the 7-bits address.
- ❑ Registers are 8 data bits wide. For read operation, data bits [15:8] are read back as 0's. For write operation, data bits [15:8] are not defined, and hence can be set to either 0's or 1's.

SMI register access is the same as the MIIM register access, except for the register access requirements presented in this section.

2.9 Advanced Switch Function

2.9.1 Port Mirroring Support

KS8993F supports “Port Mirroring” comprehensively as:

- 1) “receive only” mirror on a port** All the packets received on the port will be mirrored on the sniffer port. For example, port 1 is programmed to be “receive sniff” and port 3 is programmed to be the “sniffer port”. A packet, received on port 1, is destined to port 2 after the internal look up. The KS8993F will forward the packet to both port 2 and port 3. The KS8993F can optionally forward even “bad” received packets to the “sniffer port”.
- 2) “transmit only” mirror on a port** All the packets transmitted on the port will be mirrored on the sniffer port. For example, port 1 is programmed to be “transmit sniff” and port 3 is programmed to be the “sniffer port”. A packet received on port 2 is destined to port 1 after the internal look up. The KS8993F will forward the packet to both port 1 and port 3.
- 3) “receive and transmit” mirror on two ports** All the packets received on port A and transmitted on port B will be mirrored on the sniffer port. To turn on the “AND” feature, set register 5 bit 0 to “1”. For example, port 1 is programmed to be “receive sniff”, port 2 is programmed to be “transmit sniff” and port 3 is programmed to be the “sniffer port”. A packet received on port 1 is destined to port 2 after the internal look up. The KS8993F will forward the packet to both port 2 and 3.

Multiple ports can be selected to be “receive sniff” or “transmit sniff”. And any port can be selected to be the “sniffer port”. All these per port features can be selected through registers 17, 33 and 49 for ports 1, 2 and 3, respectively.

2.9.2 IEEE 802.1Q VLAN support

The KS8993F supports 16 active VLANs out of the 4096 possible VLANs specified in the IEEE 802.1Q specification. KS8993F provides a 16-entries VLAN Table, which converts the 12-bits VLAN ID (VID) to the 4-bits Filter ID (FID) for address look up. If a non-tagged or null-VID-tagged packet is received, the ingress port default VID is used for look up. In VLAN mode, the look up process starts with VLAN Table look up to determine whether the VID is valid. If the VID is not valid, the packet will be dropped and its address will not be learned. If the VID is valid, the FID is retrieved for further look up. The FID + Destination Address (FID+DA) are used to determine the destination port. The FID + Source Address (FID+SA) are used for address learning.

Table 7: FID+DA look up in VLAN mode

DA found in Static MAC Table?	Use FID flag?	FID match?	DA+FID found in Dynamic MAC Table?	Action
No	Don't care	Don't care	No	Broadcast to the membership ports defined in the VLAN Table bits [18:16]
No	Don't care	Don't care	Yes	Send to the destination port defined in the Dynamic MAC Address Table bits [53:52]
Yes	0	Don't care	Don't care	Send to the destination port(s) defined in the Static MAC Address Table bits [50:48]
Yes	1	No	No	Broadcast to the membership ports defined in the VLAN Table bits [18:16]
Yes	1	No	Yes	Send to the destination port defined in the Dynamic MAC Address Table bits [53:52]
Yes	1	Yes	Don't care	Send to the destination port(s) defined in the Static MAC Address Table bits [50:48]

Table 8: FID+SA look up in VLAN mode

FID+SA found in Dynamic MAC Table?	Action
No	Learn and add FID+SA to the Dynamic MAC Address Table
Yes	Update time stamp

Advanced VLAN features, such as “Ingress VLAN filtering” and “Discard Non PVID packets” are also supported by the KS8993F. These features can be set on a per port basis, and are defined in register 18, bit 6 and 5, respectively for port 1.

2.9.3 QoS Priority

This feature provides Quality of Service (QoS) for applications, such as VoIP and video conferencing. The KS8993F per port transmit queue could be split into two priority queues: a high priority queue and a low priority queue. Bit 0 of registers 16, 32 and 48 is used to enable split transmit queues for ports 1, 2 and 3, respectively. Optionally, the Px_TXQ2 strap-in pins can be used to enable this feature. With split transmit queues, high priority packets will be placed in the high priority queue and low priority packets will be placed in the low priority queue.

For split transmit queues, the KS8993F provides four priority schemes:

1. "Transmit all high priority packets before low priority packets", i.e. a low priority packet could be transmitted only when the high priority queue is empty;
2. "Transmit high priority packets and low priority packets at 10:1 ratio", i.e. transmit a low priority packet after every 10 high priority packets are transmitted, if both queues are busy;
3. "Transmit high priority packets and low priority packets at 5:1 ratio";
4. "Transmit high priority packets and low priority packets at 2:1 ratio".

If a port's transmit queue is not split, both high priority packets and low priority packets have equal priority in the transmit queue. Register 5 bits [3:2] are used to select the desired priority scheme. Optionally, the PRSEL1 and PRSEL0 strap-in pins can be used.

Port based priority

With port based priority, each ingress port can be individually classified as a high priority receiving port. All packets received at the high priority receiving port are marked as high priority, and will be sent to the high priority transmit queue if the corresponding transmit queue is split. Bit 4 of registers 16, 32 and 48 is used to enable port based priority for ports 1, 2 and 3, respectively. Optionally, the Px_PP strap-in pins can be used to enable this feature.

802.1p based priority

For 802.1p based priority, the KS8993F will examine the ingress (incoming) packets to determine whether they are tagged. If tagged, the 3-bits priority field in the VLAN tag is retrieved and compared against the "priority base" value, specified by register 2 bits [6:4]. The "priority base" value is programmable; its default value is 0x4.

The following figure illustrates how the 802.1p priority field is embedded in the 802.1Q VLAN tag.

Figure 6: 802.1p Priority Field Format

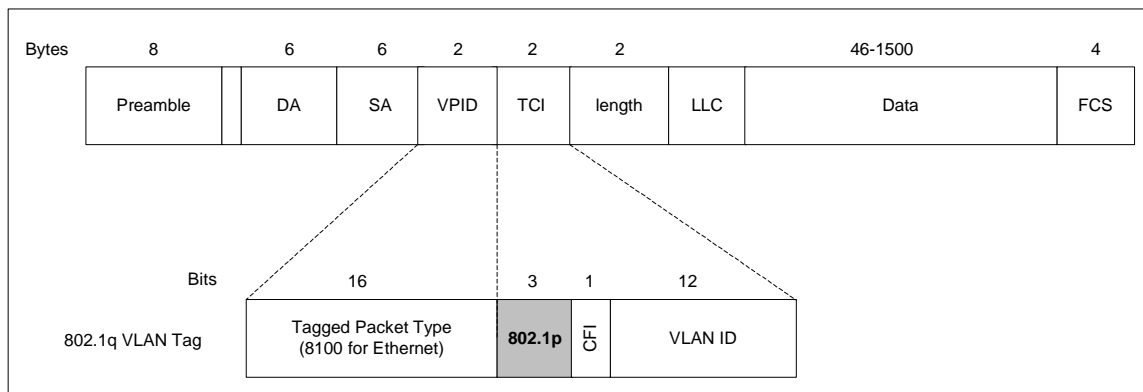

If an ingress packet has an equal or higher priority value than the "priority base" value, the packet will be placed in the high priority transmit queue if the corresponding transmit queue is split. 802.1p based priority is enabled by bit 5 of registers 16, 32 and 48 for ports 1, 2 and 3, respectively. Optionally, the Px_1PEN strap-in pins can be used to enable this feature.

The KS8993F provides the option to insert or remove the priority tagged frame's header at each individual egress port. This header, consisting of the 2 bytes VLAN Protocol ID (VPID) and the 2 bytes Tag Control Information field (TCI), is also refer to as the 802.1Q VLAN Tag.

Tag insertion is enabled by bit 2 of registers 16, 32 and 48 for ports 1, 2 and 3, respectively. Optionally, the Px_TAGINS strap-in pins can be used to enable this feature. At the egress port, untagged packets are tagged with the ingress port's default tag. The default tags are programmed in register sets {19,20}, {35,36} and {51,52} for ports 1, 2 and 3, respectively. The KS8993F will not add tags to already tagged packets.

Tag removal is enabled by bit 1 of registers 16, 32 and 48 for ports 1, 2 and 3, respectively. Optionally, the Px_TAGRM strap-in pins can be used to enable this feature. At the egress port, tagged packets will have their 802.1Q VLAN Tags removed. The KS8993F will not modify untagged packets.

The CRC is recalculated for both tag insertion and tag removal.

802.1p priority field re-mapping is a QoS feature that allows the KS8993F to set the "User Priority Ceiling" at any ingress port. If the ingress packet's priority field has a higher priority value than the default tag's priority field of the ingress port, the packet's priority field is replaced with the default tag's priority field. The "User Priority Ceiling" is enabled by bit 3 of registers 16, 32 and 48 for ports 1, 2 and 3, respectively.

DiffServ based priority

DiffServ based priority uses registers 96 to 103. More details are provided at the beginning of the **Advanced Control Registers** section.

2.9.4 Rate Limit Support

The KS8993F supports hardware rate limiting independently on the "receive side" and on the "transmit side" on a per port basis. Rate limiting is supported in both priority and non-priority environment. The rate limit starts from 0 kbps and goes up to the line rate in steps of 32 kbps. The KS8993F uses "one second" as the rate limiting interval. At the beginning of each interval, the counter is cleared to zero, and the rate limit mechanism starts to count the number of bytes during the interval.

On the "receive side", if the number of bytes exceeds the programmed limit, the switch will stop receiving packets on the port until the "one second" interval expires. Flow control can be enabled to prevent packet loss. If the rate limit is programmed greater than or equal to 128 kbps and the byte counter is 8 Kbytes below the limit, flow control will be triggered. If the rate limit is programmed lower than 128 kbps and the byte counter is 2 Kbytes below the limit, flow control will also be triggered.

On the "transmit side", if the number of bytes exceeds the programmed limit, the switch will stop transmitting packets on the port until the "one second" interval expires.

If priority is enabled, the KS8993F can be programmed to support different rate limits for high priority packets and low priority packets.

2.10 Configuration Interface

The KS8993F can operate as both a managed switch and an unmanaged switch.

In unmanaged mode, the KS8993F is typically programmed using an EEPROM. If no EEPROM is present, the KS8993F is configured using its default register settings. Some default register settings can be overridden via strap-in pin options. The strap-in pins are indicated in the "KS8993F Pin Description and I/O Assignment" table in section 1.2.

2.10.1 I²C Master Serial Bus Configuration

With an additional I²C (“2-wire”) EEPROM, the KS8993F can perform more advanced switch features like “broadcast storm protection” and “rate control” without the need of an external processor.

For KS8993F I²C Master configuration, the EEPROM stores the configuration data for register 0 to register 109 (as defined in the KS8993F register map) with the exception of the “Read Only” status registers. After the de-assertion of reset, the KS8993F will sequentially read in the configuration data for all 110 registers, starting from register 0. The configuration access time (t_{prgm}) is less than 15 ms, as depicted in the following figure.

Figure 7: KS8993F EEPROM Configuration Timing Diagram

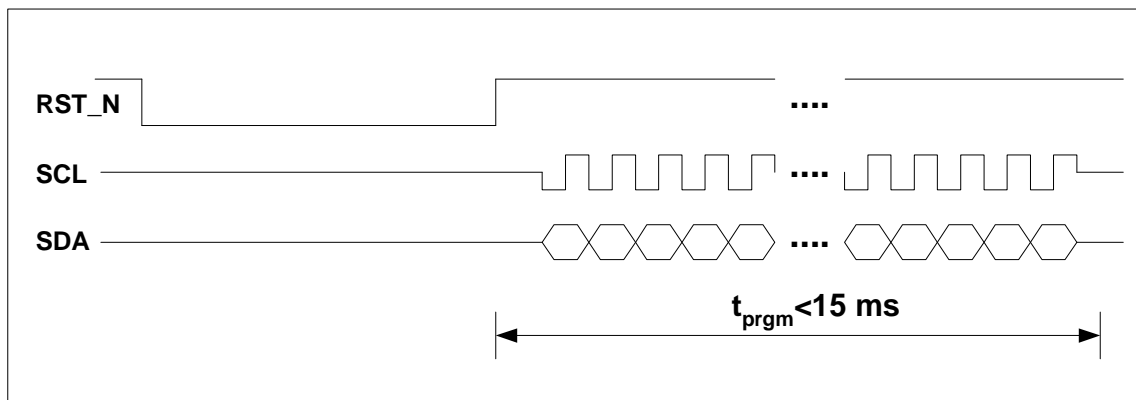

The following is a sample procedure for programming the KS8993F with a pre-configured EEPROM:

1. Connect the KS8993F to the EEPROM by joining the SCL and SDA signals of the respective devices. For the KS8993F, SCL is pin 97 and SDA is pin 98.
2. Enable I²C master mode by setting the KS8993F strap-in pins, PS[1:0] (pins 100 and 101, respectively) to “00”.
3. Check to ensure that the KS8993F reset signal input, RST_N (pin 67), is properly connected to the external reset source at the board level.
4. Program the desired configuration data into the EEPROM.
5. Place the EEPROM on the board and power up the board.
6. Assert an active-low reset to the RST_N pin of the KS8993F. After reset is de-asserted, the KS8993F will begin reading the configuration data from the EEPROM. The KS8993F will check that the first byte read from the EEPROM is “93”. If this value is correct, EEPROM configuration will continue. If not, EEPROM configuration access is denied and all other data sent from the EEPROM will be ignored by the KS8993F. The configuration access time (t_{prgm}) is less than 15 ms.

Note: For proper operation, check to ensure that the KS8993F PWRDN input signal (pin 36) is not asserted during the reset operation. The PWRDN input is active low.

2.10.2 I²C Slave Serial Bus Configuration

In managed mode, the KS8993F can be configured as an I²C slave device. In this mode, an I²C master device (external controller/CPU) has complete programming access to the KS8993F's 128 registers. Programming access includes the Global Registers, Port Registers, Media Converter Registers, Advanced Control Registers and indirect access to the "Static MAC Table", "VLAN Table", "Dynamic MAC Table" and "MIB Counters". The tables and counters are indirectly accessed via registers 110 thru 120.

In I²C slave mode, the KS8993F operates like other I²C slave devices. Addressing the KS8993F's 8 bit registers is similar to addressing Atmel's AT24C02 EEPROM's memory locations. Details of I²C read/write operations and related timing information can be found in the AT24C02 Datasheet.

Two fixed 8 bit device addresses are used to address the KS8993F in I²C slave mode. One is for read; the other is for write. The addresses are as follow:

```
1011_1111 <read>
1011_1110 <write>
```

The following is a sample procedure for programming the KS8993F using the I²C slave serial bus:

1. Enable I²C slave mode by setting the KS8993F strap-in pins PS[1:0] (pins 100 and 101 respectively) to "01".
2. Power up the board and assert reset to the KS8993F. After reset, the "Start Switch" bit (register 1 bit 0) will be set to '0'.
3. Configure the desired register settings in the KS8993F, using the I²C write operation.
4. Read back and verify the register settings in the KS8993F, using the I²C read operation.
5. Write a '1' to the "Start Switch" bit to start the KS8993F with the programmed settings.

Note: The "Start Switch" bit cannot be set to '0' to stop the switch after an '1' is written to this bit. Thus, it is recommended that all switch configuration settings are programmed before the "Start Switch" bit is set to '1'.

Some of the configuration settings, such as "Aging enable", "Auto Negotiation Enable", "Force Speed" and "Power down" can be programmed after the switch has been started.

2.10.3 SPI Slave Serial Bus Configuration

In managed mode, the KS8993F can be configured as a SPI slave device. In this mode, a SPI master device (external controller/CPU) has complete programming access to the KS8993F's 128 registers. Programming access includes the Global Registers, Port Registers, Media Converter Registers, Advanced Control Registers and indirect access to the "Static MAC Table", "VLAN Table", "Dynamic MAC Table" and "MIB Counters". The tables and counters are indirectly accessed via registers 110 thru 120.

The KS8993F supports two standard SPI commands: '0000_0011' for data read and '0000_0010' for data write. SPI multiple read and multiple write are also supported by the KS8993F to expedite register read back and register configuration, respectively.

SPI multiple read is initiated when the master device continues to drive the KS8993F SPIS_N input pin (SPI Slave Select signal) low after a byte (a register) is read. The KS8993F internal address counter will increment automatically to the next byte (next register) after the read. The next byte at the next register address will be shifted out onto the KS8993F SPIQ output pin. SPI multiple read will continue until the SPI master device terminates it by de-asserting the SPIS_N signal to the KS8993F.

Similarly, SPI multiple write is initiated when the master device continues to drive the KS8993F SPIS_N input pin low after a byte (a register) is written. The KS8993F internal address counter will increment automatically to the next byte (next register) after the write. The next byte that is sent from the master device to the KS8993F SDA input pin will be written to the next register address. SPI multiple write will continue until the SPI master device terminates it by de-asserting the SPIS_N signal to the KS8993F.

For both SPI multiple read and multiple write, the KS8993F internal address counter will wrap back to register address zero once the highest register address is reached. This feature allows all 128 KS8993F registers to be read, or written with a single SPI command and any initial register address.

The KS8993F is capable of supporting a 5 MHz SPI bus.

The following is a sample procedure for programming the KS8993F using the SPI bus:

1. At the board level, connect the KS8993F pins as follows:

Table 9: KS8993F SPI Connections

KS8993F Pin #	KS8993F Signal Name	External Processor Signal Description
99	SPIS_N	SPI Slave Select
97	SCL (SPIC)	SPI Clock
98	SDA (SPID)	SPI Data (Master output; Slave input)
96	SPIQ	SPI Data (Master input; Slave output)

2. Enable SPI slave mode by setting the KS8993F strap-in pins PS[1:0] (pins 100 and 101 respectively) to "10".
3. Power up the board and assert reset to the KS8993F. After reset, the "Start Switch" bit (register 1 bit 0) will be set to '0'.
4. Configure the desired register settings in the KS8993F, using the SPI write or multiple write command.
5. Read back and verify the register settings in the KS8993F, using the SPI read or multiple read command.
6. Write a '1' to the "Start Switch" bit to start the KS8993F with the programmed settings.

Note: The "Start Switch" bit cannot be set to '0' to stop the switch after an '1' is written to this bit. Thus, it is recommended that all switch configuration settings are programmed before the "Start Switch" bit is set to '1'.

Some of the configuration settings, such as "Aging enable", "Auto Negotiation Enable", "Force Speed" and "Power down" can be programmed after the switch has been started.

The following four figures illustrate the SPI data cycles for “Write”, “Read”, “Multiple Write” and “Multiple Read”. The read data is registered out of SPIQ on the falling edge of SPIC, and the data input on SPID is registered on the rising edge of SPIC.

Figure 8: SPI Write Data Cycle

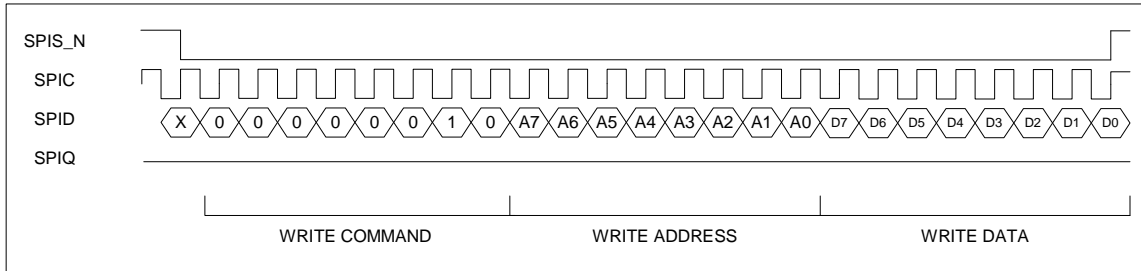

Figure 9: SPI Read Data Cycle

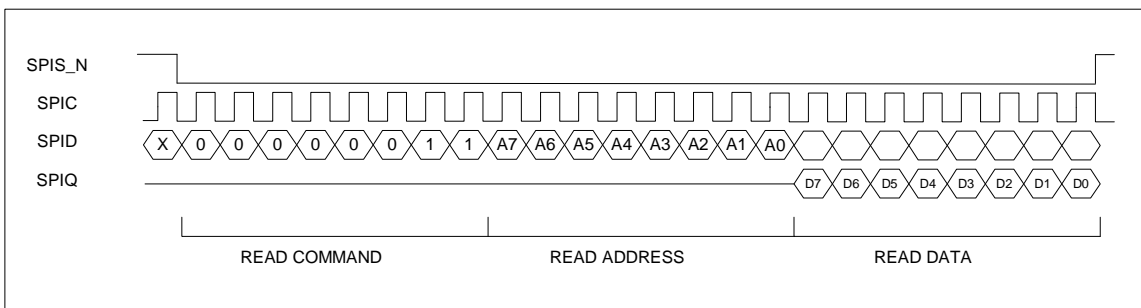

Figure 10: SPI Multiple Write

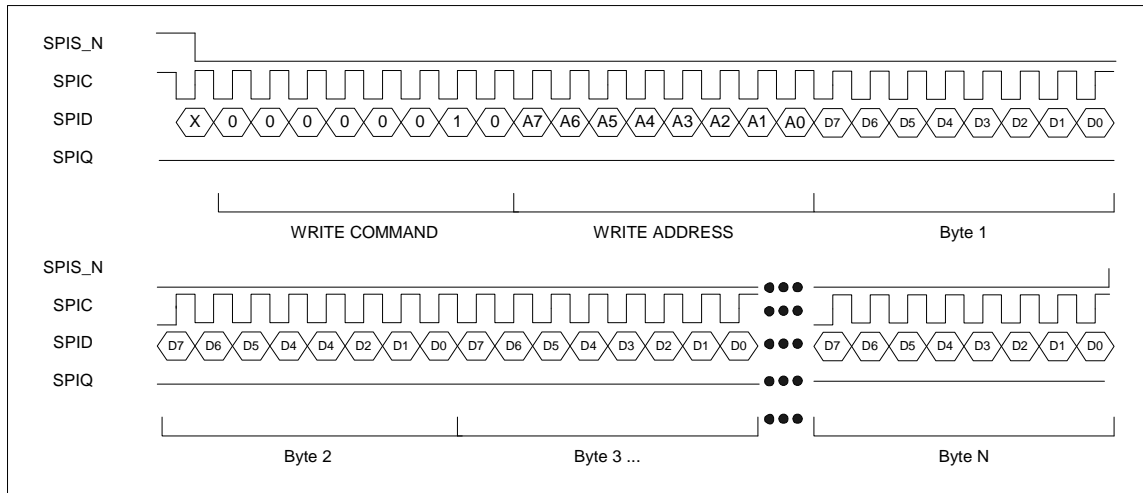
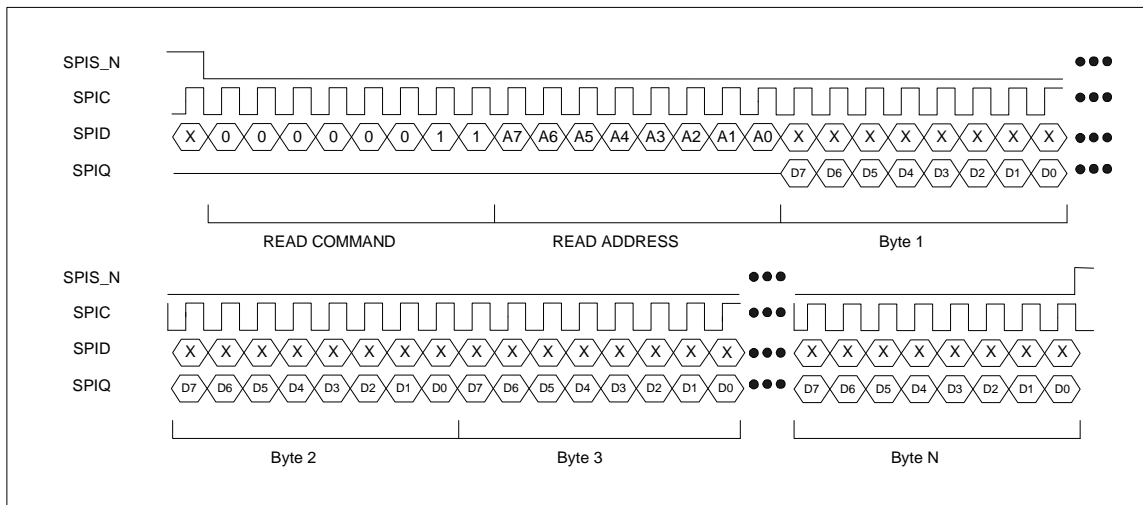

Figure 11: SPI Multiple Read



3 MII Management (MIIM) Registers

The MIIM interface is used to access the MII PHY registers defined in this section. The SPI, I2C and SMI interfaces can also be used to access these registers. The latter three interfaces use a different mapping mechanism than the MIIM interface.

As defined in the IEEE 802.3 specification, the “PHYAD” are assigned as “0x1” for PHY port 1 and “0x2” for PHY port 2. The “REGAD” supported are 0,1,2,3,4 and 5. When the switch is in “center side media converter mode”. only PHY port 1 is accessible after the PHYAD is programmed via the SPI, I2C or SMI interface.

Register Number	Description
0x0	Basic Control Register
0x1	Basic Status Register
0x2	Physical Identifier I
0x3	Physical Identifier II
0x4	Auto-Negotiation Advertisement Register
0x5	Auto-Negotiation Link Partner Ability Register
0x6 – 0x1F	Not supported

Register 0: MII Basic Control

Bit	Name	R/W	Description	Default	Reference
15	Soft reset	RO	NOT SUPPORTED	0	
14	Loop back	R/W	NOT SUPPORTED	0	
13	Force 100	R/W	=1, 100 Mbps =0, 10 Mbps	0	Reg. 28, bit 6 Reg. 44, bit 6
12	AN enable	R/W	=1, Auto-Negotiation enabled =0, Auto-Negotiation disabled	1	
11	Power down	R/W	=1, power down =0, normal operation	0	Reg. 29, bit 3 Reg. 45, bit 3
10	Isolate	RO	NOT SUPPORTED	0	
9	Restart AN	R/W	=1, restart Auto-Negotiation =0, normal operation	0	Reg. 29, bit 5 Reg. 45, bit 5
8	Force full duplex	R/W	=1, full duplex =0, half duplex	0	Reg. 28, bit 5 Reg. 44, bit 5
7	Collision test	RO	NOT SUPPORTED	0	
6	Reserved	RO		0	
5	Reserved	RO		0	
4	Force MDI	R/W	=1, force MDI (transmit on RXP/RXM pins) =0, normal operation (transmit on TXP/TXM pins)	0	Reg. 29, bit 1 Reg. 45, bit 1
3	Disable MDI-X	R/W	=1, disable auto MDI/MDI-X =0, normal operation	0	Reg. 29, bit 2 Reg. 45, bit 2
2	Disable Far-End fault	R/W	=1, disable Far-End fault detection =0, normal operation	0	Reg. 29, bit 4
1	Disable transmit	R/W	=1, disable transmit =0, normal operation	0	Reg. 29, bit 6 Reg. 45, bit 6
0	Disable LED	R/W	=1, disable LED =0, normal operation	0	Reg. 29, bit 7 Reg. 45, bit 7

Register 1: MII Basic Status

Bit	Name	R/W	Description	Default	Reference
15	T4 capable	RO	=0, Not 100 BASE-T4 capable	0	
14	100 Full capable	RO	=1, 100BASE-TX full duplex capable =0, Not capable of 100BASE-TX full duplex	1	Always 1
13	100 Half capable	RO	=1, 100BASE-TX half duplex capable =0, Not 100BASE-TX half duplex capable	1	Always 1
12	10 Full capable	RO	=1, 10BASE-T full duplex capable =0, Not 10BASE-T full duplex capable	1	Always 1
11	10 Half capable	RO	=1, 10BASE-T half duplex capable =0, Not 10BASE-T half duplex capable	1	Always 1
10-7	Reserved	RO		0	
6	Preamble suppressed	RO	NOT SUPPORTED	0	
5	AN complete	RO	=1, Auto-Negotiation complete =0, Auto-Negotiation not completed	0	Reg. 30, bit 6 Reg. 46, bit 6
4	Far-End fault	RO	=1, Far-End fault detected =0, No Far-End fault detected	0	Reg. 31, bit 0
3	AN capable	RO	=1, Auto-Negotiation capable =0, Not Auto-Negotiation capable	1	Reg. 28, bit 7 Reg. 44, bit 7
2	Link status	RO	=1, Link is up =0, Link is down	0	Reg. 30, bit 5 Reg. 46, bit 5
1	Jabber test	RO	NOT SUPPORTED	0	
0	Extended capable	RO	=0, Not extended register capable	0	

Register 2: PHYID HIGH

Bit	Name	R/W	Description	Default
15-0	PHYID high	RO	High order PHYID bits	0x0022

Register 3: PHYID LOW

Bit	Name	R/W	Description	Default
15-0	PHYID low	RO	Low order PHYID bits	0x1430

Register 4: Auto-Negotiation Advertisement Ability

Bit	Name	R/W	Description	Default	Reference
15	Next page	RO	NOT SUPPORTED	0	
14	Reserved	RO		0	
13	Remote fault	RO	NOT SUPPORTED	0	
12-11	Reserved	RO		0	
10	Pause	R/W	=1, advertise pause ability =0, do not advertise pause ability	1	Reg. 28, bit 4 Reg. 44, bit 4
9	Reserved	R/W		0	
8	Adv 100 Full	R/W	=1, advertise 100 Full duplex ability =0, do not advertise 100 full duplex ability	1	Reg. 28, bit 3 Reg. 44, bit 3
7	Adv 100 Half	R/W	=1, advertise 100 half duplex ability =0, do not advertise 100 half duplex ability	1	Reg. 28, bit 2 Reg. 44, bit 2
6	Adv 10 Full	R/W	=1, advertise 10 full duplex ability =0, do not advertise 10 full duplex ability	1	Reg. 28, bit 1 Reg. 44, bit 1
5	Adv 10 Half	R/W	=1, advertise 10 half duplex ability =0, do not advertise 10 half duplex ability	1	Reg. 28, bit 0 Reg. 44, bit 0
4-0	Selector field	RO	802.3	00001	

Register 5: Auto-Negotiation Link Partner Ability

Bit	Name	R/W	Description	Default	Reference
15	Next page	RO	NOT SUPPORTED	0	
14	LP ACK	RO	NOT SUPPORTED	0	
13	Remote fault	RO	NOT SUPPORTED	0	
12-11	Reserved	RO		0	
10	Pause	RO	Link partner pause capability	0	Reg. 30, bit 4 Reg. 46, bit 4
9	Reserved	RO		0	
8	Adv 100 Full	RO	Link partner 100 full capability	0	Reg. 30, bit 3 Reg. 46, bit 3
7	Adv 100 Half	RO	Link partner 100 half capability	0	Reg. 30, bit 2 Reg. 46, bit 2
6	Adv 10 Full	RO	Link partner 10 full capability	0	Reg. 30, bit 1 Reg. 46, bit 1
5	Adv 10 Half	RO	Link partner 10 half capability	0	Reg. 30, bit 0 Reg. 46, bit 0
4-0	Reserved	RO		00000	

4 Register Map: Switch, MC, & PHY (8 bits registers)

Global Registers

Register (Decimal)	Register (Hex)	Description
0-1	0x00 - 0x01	Chip ID Registers
2-11	0x02 - 0x0B	Global Control Registers
12	0x0C	Reserved Register
13-15	0x0D - 0x0F	User Defined Registers

Port Registers

Register (Decimal)	Register (Hex)	Description
16-29	0x10 – 0x1D	Port 1 Control Registers, including MII PHY registers
30-31	0x1E – 0x1F	Port 1 Status Registers, including MII PHY registers
32-45	0x20 – 0x2D	Port 2 Control Registers, including MII PHY registers
46-47	0x2E – 0x2F	Port 2 Status Registers, including MII PHY registers
48-61	0x30 – 0x3D	Port 3 Control Registers, including MII PHY registers
62-63	0x3E – 0x3F	Port 3 Status Registers, including MII PHY registers

Media Converter Registers

Register (Decimal)	Register (Hex)	Description
64	0x40	PHY Address
65	0x41	Center Side Status
66	0x42	Center Side Command
67	0x43	PHY-SW Initialize
68	0x44	Loop Back Setup1
69	0x45	Loop Back Setup2
70	0x46	Loop Back Result Counter for CRC Error
71	0x47	Loop Back Result Counter for Timeout
72	0x48	Loop Back Result Counter for Good Packet
73	0x49	Additional Status
74	0x4A	Remote Command1
75	0x4B	Remote Command2
76	0x4C	Remote Command3
77	0x4D	Valid MC Packet Transmitted Counter
78	0x4E	Valid MC Packet Received Counter
79	0x4F	Shadow of Register 0x58h
80	0x50	My Status 1
81	0x51	My Status 2
82	0x52	My Vendor Info (1)
83	0x53	My Vendor Info (2)
84	0x54	My Vendor Info (3)
85	0x55	My Model Info (1)
86	0x56	My Model Info (2)
87	0x57	My Model Info (3)
88	0x58	LNK Partner Status (1)
89	0x59	LNK Partner Status (2)
90	0x5A	LNK Partner Vendor Info (1)
91	0x5B	LNK Partner Vendor Info (2)

92	0x5C	LNK Partner Vendor Info (3)
93	0x5D	LNK Partner Model Info (1)
94	0x5E	LNK Partner Model Info (2)
95	0x5F	LNK Partner Model Info (3)

Advanced Control Registers

Register (Decimal)	Register (Hex)	Description
96-103	0x60-0x67	TOS Priority Control Registers
104-109	0x68-0x6D	Switch Engine's MAC Address Registers
110-111	0x6E-0x6F	Indirect Access Control Registers
112-120	0x70-0x78	Indirect Data Registers
121-122	0x79-0x7A	Digital Testing Status Registers
123-124	0x7B-0x7C	Digital Testing Control Registers
125-126	0x7D-0x7E	Analog Testing Control Registers
127	0x7F	Analog Testing Status Register

4.1 Global Registers**Register 0 (0x00): Chip ID0**

Bit	Name	R/W	Description	Default
7-0	Family ID	RO	Chip family	0x93

Register 1 (0x01): Chip ID1 / Start Switch

Bit	Name	R/W	Description	Default
7-4	Chip ID	RO	0x0 is assigned to F series. (93F)	0x0
3-1	Revision ID	RO	Revision ID	-
0	Start Switch	RW	<p>= 1, start the chip when external pins (PS1, PS0) = (0,1), (1,0), or (1,1)</p> <p>Note: In (PS1, PS0) = (0, 0) mode, the chip will start automatically after trying to read the external EEPROM. If EEPROM does not exist, the chip will use pin strapping and default values for all internal registers. If EEPROM is present, the contents in the EEPROM will be checked. The switch will check: (1) Register 0 = 0x93, (2) Register 1 bits [7:4] = 0x0. If this check is OK, the contents in the EEPROM will override chip register default values.</p> <p>= 0, chip will not start when external pins (PS1, PS0) = (0,1), (1,0), or (1,1)</p>	-

Register 2 (0x02): Global Control 0

Bit	Name	R/W	Description	Default
7	New Back-off Enable	R/W	New back-off algorithm designed for UNH 1 = Enable 0 = Disable	0x0
6-4	802.1p base priority	R/W	Used to classify priority for incoming 802.1Q packets. "user priority" is compared against this value.	0x4

			>= : classified as high priority < : classified as low priority	
3	Pass flow control packet	R/W	= 1, switch will not filter 802.1x "flow control" packets	0x0
2	Buffer share mode	R/W	= 1, buffer pool is shared by all ports. A port can use more buffer when other ports are not busy. = 0, a port is only allowed to use 1/3 of the buffer pool	0x1
1	Reserved	R/W	Reserved	0
0	Link change age	R/W	= 1, link change from "link" to "no link" will cause fast aging (<800us) to age address table faster. After an age cycle is complete, the age logic will return to normal (about 200 seconds). Note: If any port is unplugged, all addresses will be automatically aged out.	0

Register 3 (0x03): Global Control 1

Bit	Name	R/W	Description	Default
7	Pass all frames	R/W	= 1, switch all packets including bad ones. Used solely for debugging purposes. Works in conjunction with Sniffer mode only.	0
6	Repeater Mode	R/W	= 0, normal mode = 1, repeater mode (Half duplex Hub mode)	0
5	IEEE 802.3x Transmit direction flow control enable	R/W	= 1, will enable transmit direction flow control feature. = 0, will not enable transmit direction flow control feature. Switch will not generate any flow control packets.	1
4	IEEE 802.3x Receive direction flow control enable	R/W	= 1, will enable receive direction flow control feature. = 0, will not enable receive direction flow control feature. Switch will not react to any received flow control packets.	1
3	Frame Length field check	R/W	= 1, will check frame length field in the IEEE packets. If the actual length does not match, the packet will be dropped (for Length/Type field < 1500).	0
2	Aging enable	R/W	= 1, enable age function in the chip = 0, disable age function in the chip	1
1	Fast age enable	R/W	= 1, turn on fast age (800 us)	0
0	Aggressive back off enable	R/W	= 1, enable more aggressive back off algorithm in half duplex mode to enhance performance. This is not an IEEE standard.	SMAC (pin 69) value during reset

Register 4 (0x04): Global Control 2

Bit	Name	R/W	Description	Default
7	Unicast port-VLAN mismatch discard	R/W	This feature is used for port-VLAN and is described in reg. 17, reg. 33, ...) = 1, all packets can not cross VLAN boundary = 0, unicast packets (excluding unknown/multicast/broadcast) can cross VLAN boundary. Note: Port mirroring is not supported if this bit is set to '0'.	1
6	Multicast Storm protection Disable	R/W	= 1, "Broadcast Storm Protection" does not include multicast packets. Only DA = FFFFFFFF packets will be regulated. = 0, "Broadcast Storm Protection" includes DA = FFFFFFFF and DA[40] = 1 packets.	1
5	Back pressure mode	R/W	= 1, carrier sense based backpressure is selected = 0, collision based backpressure is selected	1
4	Flow control and back pressure fair mode	R/W	= 1, fair mode is selected. In this mode, if a flow control port and a non-flow control port talk to the same destination port, packets from the non-flow control port may be dropped. This is to prevent the flow control port from being flow controlled for an extended period of time. = 0, in this mode, if a flow control port and a non-flow control port talk to the same destination port, the flow control port will be flow controlled. This may not be "fair" to the flow control port.	1
3	No excessive collision drop	R/W	= 1, the switch will not drop packets when 16 or more collisions occur. = 0, the switch will drop packets when 16 or more collisions occur.	SMAC (pin 69) value during reset
2	Huge packet support	R/W	= 1, will accept packet sizes up to 1916 bytes (inclusive). This bit setting will override setting from bit 1 of the same register. = 0, the max packet size will be determined by bit 1 of this register.	0
1	Legal Maximum Packet size check enable	R/W	= 0, will accept packet sizes up to 1536 bytes (inclusive). = 1, 1522 bytes for tagged packets, 1518 bytes for untagged packets. Any packets larger than the specified value will be dropped.	SMRXD0 (pin 85) value during reset
0	Priority Buffer reserve	R/W	= 1, each output queue is pre-allocated 48 buffers, used exclusively for high priority packets. It is recommended to enable this when priority queue feature is turned on. = 0, no reserved buffers for high priority packets.	1

Register 5 (0x05): Global Control 3

Bit	Name	R/W	Description	Default
7	802.1Q VLAN enable	R/W	= 1, 802.1Q VLAN mode is turned on. VLAN table needs to set up before the operation. = 0, 802.1Q VLAN is disabled.	0
6	Reserved	R/W		0

5	Reserved	R/W		0
4	Reserved	R/W		0
3-2	Priority Scheme select	R/W	00 = always deliver high priority packets first 01 = deliver high/low packets at ratio 10/1 10 = deliver high/low packets at ratio 5/1 11 = deliver high/low packets at ratio 2/1	00
1	Reserved	R/W		0
0	Sniff mode select	R./W	= 1, will do rx AND tx sniff (both source port and destination port need to match) = 0, will do rx OR tx sniff (Either source port or destination port needs to match). This is the mode used to implement rx only sniff.	0

Register 6 (0x06): Global Control 4

Bit	Name	R/W	Description	Default
7	Reserved	R/W		0
6	Switch MII half duplex mode	R/W	=1, enable MII interface half duplex mode. =0, enable MII interface full duplex mode.	Pin SMRXD2 strap option. Pull down(0): Full duplex mode Pull up(1): Half duplex mode Note: SMRXD2 has internal pull down
5	Switch MII flow control enable	R/W	= 1, enable full duplex flow control on Switch MII interface. = 0, disable full duplex flow control on Switch MII interface.	Pin SMRXD3 strap option. Pull down(0): Disable flow control Pull up(1): Enable flow control Note: SMRXD3 has internal pull down
4	Switch MII	R/W	= 1, the switch interface is in 10Mbps mode	Pin

	10BT		= 0, the switch interface is in 100Mbps mode	SMRXD1 strap option. Pull down(0): Enable 100Mbps Pull up(1): Enable 10Mbps Note: SMRXD1 has internal pull down
3	Null VID replacement	R/W	= 1, will replace NULL VID with port VID(12 bits) = 0, no replacement for NULL VID	0
2-0	Broadcast storm protection rate Bit [10:8]	R/W	This register along with the next register determines how many "64 byte blocks" of packet data allowed on an input port in a preset period. The period is 67ms for 100BT or 500ms for 10BT. The default is 1%.	000

Register 7 (0x07): Global Control 5

Bit	Name	R/W	Description	Default
7-0	Broadcast storm protection rate Bit [7:0]	R/W	This register along with the previous register determines how many "64 byte blocks" of packet data are allowed on an input port in a preset period. The period is 67ms for 100BT or 500ms for 10BT. The default is 1%.	0x63

100BT Rate: $148,800 \text{ frames/sec} * 67 \text{ ms/interval} * 1\% = 99 \text{ frames/interval (approx.)} = 0x63$

Register 8 (0x08): Global Control 6

Bit	Name	R/W	Description	Default
7-0	Factory testing	R/W	Reserved	0x4E

Register 9 (0x09): Global Control 7

Bit	Name	R/W	Description	Default
7-0	Factory testing	R/W	Reserved	0x24

Register 10 (0x0A): Global Control 8

Bit	Name	R/W	Description	Default
7-0	Factory testing	R/W	Reserved	0x24

Register 11 (0x0B): Global Control 9

Bit	Name	R/W	Description	Default
7	Reserved		Reserved	0

6	PHY power save	R/W	= 1, enable PHY power save mode = 0, disable PHY power save mode	0																																				
5	CRC drop	R/W	In MC loop back mode, = 1, drop OAM frames and Ethernet frames with the following errors – CRC, undersize, oversize. Loop back Ethernet frames with only good CRC and valid length. = 0, drop OAM frames only. Loop back all Ethernet frames including those with errors.	P1LCRCD (pin 18) value during reset																																				
4	Reserved	RW	Testing mode, must be 0	0																																				
3	MCLBM1	R/W	<u>MCLBM1</u> <u>MCLBM0</u> <u>Loop back position</u>	1																																				
2	MCLBM0	R/W	1 0 at Port 2 MAC MCLBM[1:0] = {0,0}, {0,1} and {1,1} are reserved. Do not use these settings.	P1LPBM (pin 19) value during reset. This value needs to be "0".																																				
1	LED mode	R/W	This register bit sets the LEDSEL0 selection only. LEDSEL1 is set via strap-in pin. Port x LED Indicators , defined as below: <table border="1" style="margin-left: auto; margin-right: auto;"> <thead> <tr> <th colspan="3">[LEDSEL1, LEDSEL0]</th> </tr> <tr> <th></th> <th>[0, 0]</th> <th>[0, 1]</th> </tr> </thead> <tbody> <tr> <td>PxLED3</td> <td>-----</td> <td>-----</td> </tr> <tr> <td>PxLED2</td> <td>LINK/ACT</td> <td>100LINK/ACT</td> </tr> <tr> <td>PxLED1</td> <td>FULL_DPX/COL</td> <td>10LINK/ACT</td> </tr> <tr> <td>PxLED0</td> <td>SPEED</td> <td>FULL_DPX</td> </tr> </tbody> </table> <table border="1" style="margin-left: auto; margin-right: auto;"> <thead> <tr> <th colspan="3">[LEDSEL1, LEDSEL0]</th> </tr> <tr> <th></th> <th>[1, 0]</th> <th>[1, 1]</th> </tr> </thead> <tbody> <tr> <td>PxLED3</td> <td>ACT</td> <td>-----</td> </tr> <tr> <td>PxLED2</td> <td>LINK</td> <td>-----</td> </tr> <tr> <td>PxLED1</td> <td>FULL_DPX/COL</td> <td>-----</td> </tr> <tr> <td>PxLED0</td> <td>SPEED</td> <td>-----</td> </tr> </tbody> </table> <u>Notes:</u> LEDSEL0 is external strap-in pin #70. LEDSEL1 is external strap-in pin #23.	[LEDSEL1, LEDSEL0]				[0, 0]	[0, 1]	PxLED3	-----	-----	PxLED2	LINK/ACT	100LINK/ACT	PxLED1	FULL_DPX/COL	10LINK/ACT	PxLED0	SPEED	FULL_DPX	[LEDSEL1, LEDSEL0]				[1, 0]	[1, 1]	PxLED3	ACT	-----	PxLED2	LINK	-----	PxLED1	FULL_DPX/COL	-----	PxLED0	SPEED	-----	LEDSEL0 (pin 70) value during reset
[LEDSEL1, LEDSEL0]																																								
	[0, 0]	[0, 1]																																						
PxLED3	-----	-----																																						
PxLED2	LINK/ACT	100LINK/ACT																																						
PxLED1	FULL_DPX/COL	10LINK/ACT																																						
PxLED0	SPEED	FULL_DPX																																						
[LEDSEL1, LEDSEL0]																																								
	[1, 0]	[1, 1]																																						
PxLED3	ACT	-----																																						
PxLED2	LINK	-----																																						
PxLED1	FULL_DPX/COL	-----																																						
PxLED0	SPEED	-----																																						
0	Reserved	R/W	Reserved	0																																				

Register 12 (0x0C): Reserved Register

Bit	Name	R/W	Description	Default
7-0	Reserved		Reserved	0x00

Register 13 (0x0D): User Defined Register 1

Bit	Name	R/W	Description	Default
7-0	UDR1	R/W		0x00

Register 14 (0x0E): User Defined Register 2

Bit	Name	R/W	Description	Default
7-0	UDR2	R/W		0x00

Register 15 (0x0F): User Defined Register 3

Bit	Name	R/W	Description	Default
7-0	UDR3	R/W		0x00

4.2 Port Registers

The following registers are used to enable features that are assigned on a per port basis. The register bit assignments are the same for all ports, but the address for each port is different, as indicated.

Register 16 (0x10): Port 1 Control 0*Register 32 (0x20): Port 2 Control 0**Register 48 (0x30): Port 3 Control 0*

Bit	Name	R/W	Description	Default
7	Broadcast storm protection enable	R/W	= 1, enable broadcast storm protection for ingress packets on the port = 0, disable broadcast storm protection	0
6	Diffserv priority classification enable	R/W	= 1, enable diffserv priority classification for ingress packets on port = 0, disable diffserv function	0
5	802.1p priority classification enable	R/W	= 1, enable 802.1p priority classification for ingress packets on port = 0, disable 802.1p	Pin value during reset: P1_1PEN (port 1), P2_1PEN (port 2), P3_1PEN (port 3)
4	Port based priority classification enable	R/W	= 1, ingress packets on the port will be classified as high priority if "Diffserv" or "802.1p" classification is not enabled or fails to classify. = 0, ingress packets on port will be classified as low priority if "Diffserv" or "802.1p" classification is not enabled or fails to classify. Note: "Diffserv", "802.1p" and port priority can be enabled at the same time. The OR'ed result of 802.1p and DSCP overwrites the port priority.	Pin value during reset: P1_PP (port 1), P2_PP (port 2), P3_PP (port 3)
3	User Priority Ceiling	R/W	= 1, if the packet's "user priority field" is greater than the "user priority field" in the port default tag register, replace the packet's "user priority field" with the "user priority field" in the port default tag register. = 0, do no compare and replace the packet's 'user priority field"	0
2	Tag insertion	R/W	= 1, when packets are output on the port, the switch will add 802.1p/q tags to packets without 802.1p/q tags when received. The switch will not add tags to packets already tagged. The tag inserted is the ingress port's "port VID".	Pin value during reset: P1_TAGINS (port 1), P2_TAGINS (port 2),

			= 0, disable tag insertion	P3_TAGINS (port 3)
1	Tag removal	R/W	= 1, when packets are output on the port, the switch will remove 802.1p/q tags from packets with 802.1p/q tags when received. The switch will not modify packets received without tags. = 0, disable tag removal	Pin value during reset: P1_TAGRM (port 1), P2_TAGRM (port 2), P3_TAGRM (port 3)
0	Priority Enable	R/W	= 1, the port output queue is split into high and low priority queues. = 0, single output queue on the port. There is no priority differentiation even though packets are classified into high or low priority.	Pin value during reset: P1_TXQ2 (port 1), P2_TXQ2 (port 2), P3_TXQ2 (port 3)

Register 17 (0x11): Port 1 Control 1*Register 33 (0x21): Port 2 Control 1**Register 49 (0x31): Port 3 Control 1*

Bit	Name	R/W	Description	Default
7	Sniffer port	R/W	= 1, Port is designated as sniffer port and will transmit packets that are monitored. = 0, Port is a normal port	0
6	Receive sniff	R/W	= 1, All the packets received on the port will be marked as "monitored packets" and forwarded to the designated "sniffer port" = 0, no receive monitoring	0
5	Transmit sniff	R/W	= 1, All the packets transmitted on the port will be marked as "monitored packets" and forwarded to the designated "sniffer port" = 0, no transmit monitoring	0
4	Double tag	R/W	= 1, all packets will be tagged with port default tag of ingress port regardless of the original packets are tagged or not = 0, do not double tagged on all packets	0
3	Reserved	R/W		0
2-0	Port VLAN membership	R/W	Define the port's Port VLAN membership. Bit 2 stands for port 3, bit 1 for port 2, and bit 0 for port 1. The Port can only communicate within the membership. An '1' includes a port in the membership; an '0' excludes a port from the membership.	Pin value during reset: For port 1, (PV13, PV12, 1) For port 2, (PV23, 1, PV21) For port 3, (1, PV32, PV31)

Register 18 (0x12): Port 1 Control 2*Register 34 (0x22): Port 2 Control 2**Register 50 (0x32): Port 3 Control 2*

Bit	Name	R/W	Description	Default
-----	------	-----	-------------	---------

7	Reserved		Reserved	0
6	Ingress VLAN filtering	R/W	= 1, the switch will discard packets whose VID port membership in VLAN table bits [18:16] does not include the ingress port. = 0, no ingress VLAN filtering	0
5	Discard Non PVID packets	R/W	= 1, the switch will discard packets whose VID does not match ingress port default VID. = 0, no packets will be discarded	0
4	Force flow control	R/W	= 1, will always enable flow control on the port, regardless of AN result. = 0, the flow control is enabled based on AN result.	Pin value during reset: For port 1, P1FFC pin For port 2, P2FFC pin For port 3, this bit has no meaning. Flow control is controlled by Reg. 6, bit 5
3	Back pressure enable	R/W	= 1, enable port's half duplex back pressure = 0, disable port's half duplex back pressure.	Pin value during reset: BPEN pin
2	Transmit enable	R/W	= 1, enable packet transmission on the port = 0, disable packet transmission on the port	1
1	Receive enable	R/W	= 1, enable packet reception on the port = 0, disable packet reception on the port	1
0	Learning disable	R/W	= 1, disable switch address learning capability = 0, enable switch address learning capability	0

Register 19 (0x13): Port 1 Control 3

Register 35 (0x23): Port 2 Control 3

Register 51 (0x33): Port 3 Control 3

Bit	Name	R/W	Description	Default
7-0	Default tag [15:8]	R/W	Port's default tag, containing 7-5 : User Priority bits 4 : CFI bit 3-0 : VID[11:8]	0x00

Register 20 (0x14): Port 1 Control 4

Register 36 (0x24): Port 2 Control 4

Register 52 (0x34): Port 3 Control 4

Bit	Name	R/W	Description	Default
7-0	Default tag [7:0]	R/W	Port's default tag, containing 7-0 : VID[7:0]	0x01

Note: Registers 19 and 20 (and those corresponding to other ports) serve two purposes:
 (1) Associated with the ingress untagged packets, and used for egress tagging.
 (2) Default VID for the ingress untagged or null-VID-tagged packets, and used for address look up.

Register 21 (0x15): Port 1 Control 5*Register 37 (0x25): Port 2 Control 5**Register 53 (0x35): Port 3 Control 5*

Bit	Name	R/W	Description	Default
7-0	Transmit high priority rate control [7:0]	R/W	This register along with port control 7, bits [3:0] form a 12-bits field to determine how many "32Kbps" high priority blocks can be transmitted. (in a unit of 4K bytes in a one second period).	0x00

Register 22 (0x16): Port 1 Control 6*Register 38 (0x26): Port 2 Control 6**Register 54 (0x36): Port 3 Control 6*

Bit	Name	R/W	Description	Default
7-0	Transmit low priority rate control [7:0]	R/W	This register along with port control 7, bits [7:4] form a 12-bits field to determine how many "32Kbps" low priority blocks can be transmitted. (in a unit of 4K bytes in a one second period).	0x00

Register 23 (0x17): Port 1 Control 7*Register 39 (0x27): Port 2 Control 7**Register 55 (0x37): Port 3 Control 7*

Bit	Name	R/W	Description	Default
7-4	Transmit low priority rate control [11:8]	R/W	These bits along with port control 6, bits [7:0] form a 12-bits field to determine how many "32Kbps" low priority blocks can be transmitted. (in a unit of 4K bytes in a one second period)	0x0
3-0	Transmit high priority rate control [11:8]	R/W	These bits along with port control 5, bits [7:0] form a 12-bits field to determine how many "32Kbps" high priority blocks can be transmitted. (in a unit of 4K bytes in a one second period)	0x0

Register 24 (0x18): Port 1 Control 8*Register 40 (0x28): Port 2 Control 8**Register 56 (0x38): Port 3 Control 8*

Bit	Name	R/W	Description	Default
7-0	Receive high priority rate control [7:0]	R/W	This register along with port control 10, bits [3:0] form a 12-bits field to determine how many "32Kbps" high priority blocks can be received. (in a unit of 4K bytes in a one second period)	0x00

Register 25 (0x19): Port 1 Control 9*Register 41 (0x29): Port 2 Control 9**Register 57 (0x39): Port 3 Control 9*

Bit	Name	R/W	Description	Default
7-0	Receive low priority rate control [7:0]	R/W	This register along with port control 10, bits [7:4] form a 12-bits field to determine how many "32Kbps" low priority blocks can be received. (in a unit of 4K bytes in a one second period)	0x00

Register 26 (0x1A): Port 1 Control 10*Register 42 (0x2A): Port 2 Control 10**Register 58 (0x3A): Port 3 Control 10*

Bit	Name	R/W	Description	Default
7-4	Receive low priority rate control [11:8]	R/W	These bits along with port control 9, bits [7:0] form a 12-bits field to determine how many "32Kbps" low priority blocks can be received. (in a unit of 4K bytes in a one second period)	0x0

3-0	Receive high priority rate control [11:8]	R/W	These bits along with port control 8, bits [7:0] form a 12-bits field to determine how many "32Kbps" high priority blocks can be received. (in a unit of 4K bytes in a one second period)	0x0
-----	---	-----	---	-----

Register 27 (0x1B): Port 1 Control 11*Register 43 (0x2B): Port 2 Control 11**Register 59 (0x3B): Port 3 Control 11*

Bit	Name	R/W	Description	Default
7	Receive differential priority rate control	R/W	= 1, If bit 6 is also '1', this will enable receive rate control for this port on low priority packets at the low priority rate. If bit 5 is also '1', this will enable receive rate control on high priority packets at the high priority rate. = 0, receive rate control will be based on the low priority rate for all packets on this port.	0
6	Low priority receive rate control enable	R/W	= 1, enable port's low priority receive rate control feature = 0, disable port's low priority receive rate control feature	0
5	High priority receive rate control enable	R/W	= 1, If bit 7 is also '1', this will enable the port's high priority receive rate control feature. If bit 7 is a '0' and bit 6 is a '1', all receive packets on this port will be rate controlled at the low priority rate. = 0, disable port's high priority receive rate control feature	0
4	Low priority receive rate flow control enable	R/W	= 1, flow control may be asserted if the port's low priority receive rate is exceeded = 0, flow control is not asserted if the port's low priority receive rate is exceeded	0
3	High priority receive rate flow control enable	R/W	= 1, flow control may be asserted if the port's high priority receive rate is exceeded. (to use this, differential receive rate control must be ON) = 0, flow control is not asserted if the port's high priority receive rate is exceeded.	0
2	Transmit differential priority rate control	R/W	= 1, will do transmit rate control on both high and low priority packets based on the rate counters defined by the high and low priority packets respectively. = 0, will do transmit rate control on any packets. The rate counters defined in low priority will be used.	0
1	Low priority transmit rate control enable	R/W	= 1, enable the port's low priority transmit rate control feature = 0, disable the port's low priority transmit rate control feature	0
0	High priority transmit rate control enable	R/W	= 1, enable the port's high priority transmit rate control feature = 0, disable the port's high priority transmit rate control feature	0

NOTE: Port Control Registers 12 and 13, and Port Status Register 0 contents can also be accessed with the MIIM (MDC/MDIO) interface via the standard MIIM registers.

Register 28 (0x1C): Port 1 Control 12*Register 44 (0x2C): Port 2 Control 12**Register 60 (0x3C): Reserved, not applied to port 3*

Bit	Name	R/W	Description	Default
-----	------	-----	-------------	---------

7	Auto Negotiation Enable	R/W	= 0, disable auto negotiation, speed and duplex are decided by bit 6 and 5 of the same register. = 1, auto negotiation is ON	For port 1, P1ANEN pin value during reset For port 2, P2ANEN pin value during reset
6	Force Speed	R/W	= 1, force 100BT if AN is disabled (bit 7) = 0, force 10BT if AN is disabled (bit 7)	For port 1, P1SPD pin value during reset. For port 2, P2SPD pin value during reset
5	Force duplex	R/W	= 1, force full duplex if (1) AN is disabled or (2) AN is enabled but failed. = 0, force half duplex if (1) AN is disabled or (2) AN is enabled but failed.	For port 1, P1DPX pin value during reset. For port 2, P2DPX pin value during reset
4	Advertised flow control capability	R/W	= 1, advertise flow control (pause) capability = 0, suppress flow control (pause) capability from transmission to link partner	ADVFC pin value during reset
3	Advertised 100BT Full duplex capability	R/W	= 1, advertise 100BT Full duplex capability = 0, suppress 100BT Full duplex capability from transmission to link partner	1
2	Advertised 100BT Half duplex capability	R/W	= 1, advertise 100BT Half duplex capability = 0, suppress 100BT Half duplex capability from transmission to link partner	1
1	Advertised 10BT Full duplex capability	R/W	= 1, advertise 10BT Full duplex capability = 0, suppress 10BT Full duplex capability from transmission to link partner	1
0	Advertised 10BT Half duplex capability	R/W	= 1, advertise 10BT Half duplex capability = 0, suppress 10BT Half duplex capability from transmission to link partner	1

Register 29 (0x1D): Port 1 Control 13*Register 45 (0x2D): Port 2 Control 13**Register 61 (0x3D): Reserved, not applied to port 3*

Bit	Name	R/W	Description	Default
7	LED off	R/W	= 1, Turn off all port's LEDs (LEDx_3, LEDx_2, LEDx_1, LEDx_0, where "x" is the port number). These pins will be driven high if this bit is set to one.	0

			= 0, normal operation	
6	Txids	R/W	= 1, disable port's transmitter = 0, normal operation	0
5	Restart AN	R/W	= 1, restart auto negotiation = 0, normal operation	0
4	Disable Far-End fault	R/W	= 1, disable Far-End fault detection & pattern transmission. = 0, enable Far-End fault detection & pattern transmission	0 Note: Only Port 1 supports fiber. This bit is applicable to port 1 only.
3	Power down	R/W	= 1, power down = 0, normal operation	0
2	Disable auto MDI/MDI-X	R/W	= 1, disable auto MDI/MDI-X function = 0, enable auto MDI/MDI-X function	0 For port 2, P2MDIXDIS pin value during reset
1	Force MDI	R/W	If auto MDI/MDI-X is disabled, = 1, force PHY into MDI mode (transmit on RXP/RXM pins) = 0, force PHY into MDI-X mode (transmit on TXP/TXM pins)	0 For port 2, P2MDIX pin value during reset
0	Reserve	R/W	= 1, reserve = 0, normal operation	0

Register 30 (0x1E): Port 1 Status 0*Register 46 (0x2E): Port 2 Status 0**Register 62 (0x3E): Reserved, not applied to port 3*

Bit	Name	R/W	Description	Default
7	MDI-X status	RO	= 1, MDI-X = 0, MDI	0
6	AN done	RO	= 1, AN done = 0, AN not done	0
5	Link good	RO	= 1, Link good = 0, Link not good	0
4	Partner flow control capability	RO	= 1, link partner flow control (pause) capable = 0, link partner not flow control (pause) capable	0
3	Partner 100BT Full duplex capability	RO	= 1, link partner 100BT Full duplex capable = 0, link partner not 100BT Full duplex capable	0
2	Partner 100BT Half duplex capability	RO	= 1, link partner 100BT Half duplex capable = 0, link partner not 100BT Half duplex capable	0

1	Partner 10BT Full duplex capability	RO	= 1, link partner 10BT Full duplex capable = 0, link partner not 10BT Full duplex capable	0
0	Partner 10BT Half duplex capability	RO	= 1, link partner 10BT Half duplex capable = 0, link partner not 10BT Half duplex capable	0

Register 31 (0x1F): Port 1 Status 1*Register 47 (0x2F): Port 2 Status 1**Register 63 (0x3F): Port 3 Status 1*

Bit	Name	R/W	Description	Default
7	Reserved	RO		0
6-5	Reserved	RO		00
4	Receive flow control enable	RO	1 = Receive flow control feature is active 0 = Receive flow control feature is inactive	0
3	Transmit flow control enable	RO	1 = transmit flow control feature is active 0 = transmit flow control feature is inactive	0
2	Operation Speed	RO	1 = link speed is 100Mbps 0 = link speed is 10Mbps	0
1	Operation duplex	Ro	1 = link duplex is full 0 = link duplex is half	0
0	Far-End fault	RO	1 = Far-End fault status detected 0 = no Far-End fault status detected	0

Note:
Only Port 1 supports fiber.
This bit is applicable to port 1 only.

4.3 Media Converter Registers

Register 64 (0x40): PHY Address

Bit	Name	R/W	Description	Default
7–5	Reserved	RO	N/A	000
4	Addr4	R/W	For Center side MC mode , these bits are port 1's PHY address. 0 0000 : N/A 0 0001 : Port 1's PHY address is 0x01h 0 0011 : Port 1's PHY address is 0x03h other values : N/A For Terminal side MC mode , these bits are fixed at 0x01h for port 1's PHY address. Notes (1) If pins [MCHS,MCCS] = [0,1], a write to these bits with port 1's PHY address is required to enable port 1 and start the Center side MC. (2) If pins [MCHS,MCCS] = [0,1], the MIIM bus can only access port 1. (3) If pins [MCHS, MCCS] != [0,1], the MIIM bus will access port 1 using PHY address 0x01h and port 2 using PHY address 0x02h.	0
3	Addr3	R/W		0
2	Addr2	R/W		0
1	Addr1	R/W		0
0	Addr0	R/W		1

Register 65 (0x41): Center Side Status

Bit	Name	R/W	Description	Default
7	BUSY	RO	1 = indicate MC loop back mode inprogress, or receive reply frame/timeout is pending 0 = exclude the above situations	0
6	Vendor mode	R/W	1 = non special vendor mode 0 = special vendor mode (compare My & LNK Partner Vendor Info = 0x009099h)	0
5–3	Reserved	RO	Reserved	000
2	Option b	R/W	1 = clear status bits S6 to S10 to zero on Terminal MC side 0 = normal operation – supporting option b	0
1	Option a	R/W	1 = disable “Indicate Center MC Condition” frame 0 = enable “Indicate Center MC condition” frame	0
0	Request	RO	1 = indicate change of status/value in registers # 0x50h, 0x51h, 0x58h, 0x59h, 0x5Dh, 0x5Eh, 0x5Fh. This bit is self-cleared after a read. 0 = exclude the above situations	0

Note: This register is managed by the Center side.

Register 66 (0x42): Center Side Command

Bit	Name	R/W	Description	Default
7-5	Timer Delay	R/W	000 = Reserved (Do Not Use) 001 = 32us (default) 010 = 128us 011 = 256us 100 = 512us 101 = 1ms 110 = 2m 111 = 4ms	001
4	Com4	R/W	To send a maintenance frame, an external controller writes to these command bits via the SMI, SPI, or I2C interface. 0 0000 : No request 0 0001 : Send "Condition Inform Request" frame 0 0010 : Send "Loop Mode Start Request" frame 0 0100 : Send "Loop Mode Stop Request" frame 0 1000 : Send "Remote Command". Here, the Maintenance frame will be made up of the "Condition Inform Request/Reply" frame, but the My Model Info bits MM24-MM47 will be mapped to Registers 4Ah-4Ch, instead of Registers 55h-57h. 1 0000 : Send "Indicate Center/Terminal MC Condition" frame. Usually, "Indicate Center/Terminal MC Condition" frame will be sent automatically. But this OAM frame can be sent manually using this command. Other values : N/A Note Except for the "Indicate Center/Terminal MC Condition" frame, all maintenance frames here are sent by the Center side MC only.	0
3	Com3	R/W		0
2	Com2	R/W		0
1	Com1	R/W		0
0	Com0	R/W		0

Register 67 (0x43): PHY-SW Initialize

Bit	Name	R/W	Description	Default
7	P2 SPEED	R/W	1 = 100Mbps 0 = 10Mbps This bit share the same physical register as Reg. 2Ch bit 6.	P2SPD pin value during reset
6	P2 DUPLEX	R/W	1 = Full duplex 0 = Half duplex This bit share the same physical register as Reg. 2Ch bit 5.	P2DPX pin value during reset
5	P2 Auto Negotiation	R/W	1 = AN enable 0 = AN disable This bit share the same physical register as Reg. 2Ch bit 7.	P2ANEN pin value during reset

4	SW reset	R/W	1 = reset MC sub-layer, MACs of both PHY ports and switch fabric to their default states. This bit is self-cleared after an '1' is written to it. 0 = normal operation	0
3	Remote Command Enable	R/W	1 = enable "Remote Command" access at Center side and Terminal side 0 = disable "Remote Command" access at Center side and Terminal side	0
2	Enhanced ML_EN	R/W	1 = defined as follows: In Terminal side MC mode , if a link down is detected on the fiber or the Center side UTP, the Terminal side will disable the TX on its UTP and turn off the LEDs to its UTP. In Center side MC mode , this bit has no meaning. 0 = normal operation	ML_EN pin value during reset
1	P1 TX_DIS	R/W	1 = disable (tri-state) transmit to Fiber PHY (port 1) 0 = normal operation	0
0	PHY reset	R/W	1 = reset the PHY of both PHY ports to their default states. This bit is self-cleared after an '1' is written to it. 0 = normal operation Note: MC (maintenance) sub-layer registers are not reset by this bit.	1 (Powered on value in Center side MC mode. After reg. 0x40h is programmed, this bit will be cleared.) ----- 0 (Default value for non Center side MC mode)

Register 68 (0x44): Loop Back Setup1

Bit	Name	R/W	Description	Default
7	T7	R/W	Center and Terminal sides	0
6	T6	R/W		0
5	T5	R/W		0
4	T4	R/W		0
3	T3	R/W		0
2	T2	R/W		1
1	T1	R/W		1
0	T0	R/W		1
			0000_0000 : Clear valid transmit and valid receive counters in registers 4Dh and 4Eh. Also for center side, clear loop back counters in registers 46h, 47h and 48h.	
			Center side only	
			0000_0001 : Send 1 MC loop back packet	
			0000_0010 : Send 2 MC loop back packets	
			:	
			0000_0111 : Send 7 MC loop back packets (default)	
			:	
			0110_0100 : Send 100 MC loop back packets	
			other values (0x65h to 0xFFh) : N/A	

Register 69 (0x45): Loop Back Setup2

Bit	Name	R/W	Description	Default	
7	P7	R/W	Center side only	0	
6	P6	R/W		Use to select pattern for MC loop back packet	0
5	P5	R/W		0	
4	P4	R/W		0000_0000 : 64 bytes DA: Unicast Data: 55AA	0
3	P3	R/W		0000_0001 : 1518 bytes DA: Unicast Data: 55AA	0
2	P2	R/W		0000_0010 : 64 bytes DA: Broadcast Data: 55AA	0
1	P1	R/W		0000_0100 : 1518 bytes DA: Broadcast Data: 55AA	0
0	P0	R/W		0000_1000 : 64 bytes DA: Unicast Data: 0F0F	0
				0001_0000 : 1518 bytes DA: Unicast Data: 0F0F	
				0010_0000 : 64 bytes DA: Broadcast Data: 0F0F	
			0100_0000 : 1518 bytes DA: Broadcast Data: 0F0F		
			1000_0000 : 1518 bytes DA: Broadcast Data: FF00		
			other values : N/A		
			where the packet's:		
			DA is [Register #52h][Register #53h][Register #54h] [Register #55h][Register #56h]([Register #57h] + 1).		
			And the last byte ([Register #57h] + 1) increments repeatedly by 1 for the next loop back packet.		
			SA is [Register #52h][Register #53h][Register #54h] [Register #55h][Register #56h][Register #57h]		
			Type/length is 0x0800h		

Register 70 (0x46): Loop Back Result Counter for CRC Error

Bit	Name	R/W	Description	Default
7	CRC7	RO	Center side only This counter is incremented when loop back packet has CRC error. 0000_0000 : No CRC error received 0000_0001 : 1 CRC error received : 1111_1111 : 255 CRC errors received This counter is cleared when 0x00h is written to reg. 0x44h.	0
6	CRC6	RO		0
5	CRC5	RO		0
4	CRC4	RO		0
3	CRC4	RO		0
2	CRC2	RO		0
1	CRC1	RO		0
0	CRC0	RO		0

Register 71 (0x47): Loop Back Result Counter for Timeout

Bit	Name	R/W	Description	Default
7	TO7	RO	Center side only This counter is incremented when loop back packet has timeout. 0000_0000 : No timeout occurred 0000_0001 : 1 timeout occurred : 1111_1111 : 255 timeouts occurred This counter is cleared when 0x00h is written to reg. 0x44h.	0
6	TO6	RO		0
5	TO5	RO		0
4	TO4	RO		0
3	TO3	RO		0
2	TO2	RO		0
1	TO1	RO		0
0	TO0	RO		0

Register 72 (0x48): Loop Back Result Counter for Good Packet

Bit	Name	R/W	Description	Default
7	GO7	RO	Center side only This counter is incremented when loop back packet is returned good. 0000_0000 : No good packet 0000_0001 : 1 good packet : 1111_1111 : 255 good packets This counter is cleared when 0x00h is written to reg. 0x44h.	0
6	GO6	RO		0
5	GO5	RO		0
4	GO4	RO		0
3	GO3	RO		0
2	GO2	RO		0
1	GO1	RO		0
0	GO0	RO		0

Register 73 (0x49): Additional Status (Center and Terminal side)

Bit	Name	R/W	Description	Default
7	Hard Version 1	RO	Hard Version (bits [7:6])	0
6	Hard Version 0	RO		1
5	Model Version 1	RW	Model Version (bits [5:4]): 00: 15km model 01: 40km model others: Reserved	0
4	Model Version 0	RW		0
3	HMC Loop	RO	1 = Center side receives "Loop Mode Stop Indication" frame from the	0

	Back Timeout		Terminal side. This bit is self-cleared after it is read. 0 = normal operation	
2	CMC Loop Back Timeout	RO	1 = Center side is in Loop Back mode too long and the T1 timer has timeout. This bit is self-cleared after it is read. 0 = normal operation	0
1	Timeout	RO	1 = Center side does not receive reply frame from the Terminal side and the TE timer has timeout. This bit is self-cleared after it is read. 0 = normal operation	0
0	P1 LNK Down	RO	1 = Link is down on port 1 0 = Link is up on port 1	0

NOTE: Registers 74, 75 and 76 are accessed by the Center side only

Register 74 (0x4A): Remote Command 1

Bit	Name	R/W	Description	Default
7	AMM31	R/W	Reserved	0
6	AMM30	R/W	(These two bits must be set to '00' for normal operation)	0
5	AMM29	R/O	Indicate support capability for "A-vendor" only. If Operating Mode (bits[1:0] of this register) is set to "10", these two bits are used by "A-vendor" to indicate support for "extended mode". 10: Support "extended mode" others: Reserved	1
4	AMM28	R/O		0
3	AMM27	R/W	Operating Code If Operating Mode (bits[1:0] of this register) is set to "10", these two bits are used to select one of the following Operating Codes: 00: read reply 01: read request 10: write reply 11: write request	0
2	AMM26	R/W		0
1	AMM25	R/W	Operating Mode Select between "normal mode" and "extended mode", defined as follows: 00: normal mode, MM24-MM47 (registers 0x55h to 0x57h) are used for My Model Info. 10: extended mode, MM24-MM47 (registers 0x55h to 0x57h) are mapped to Remote Command (registers 0x4Ah to 0x4Ch) 01: reserved 11: reserved	1
0	AMM24	R/W		0

Register 75 (0x4B): Remote Command 2

Bit	Name	R/W	Description	Default
7	AMM39	R/W	If Center MC sends the "Remote Command" in register 0x42h, this register value will be used for M39-M32 of the Maintenance frame, instead of register 0x56h. [AMM39:AMM32] = bits[7:0] of the KS8993F address byte if the Operating Mode in register 0x4Ah bits[1:0] is set to "10"	0
6	AMM38	R/W		0
5	AMM37	R/W		0
4	AMM36	R/W		0
3	AMM35	R/W		0
2	AMM34	R/W		0
1	AMM33	R/W		0
0	AMM32	R/W	0	

Register 76 (0x4C): Remote Command 3

Bit	Name	R/W	Description	Default
7	AMM47	R/W	If Center MC sends the "Remote Command" in register 0x42h, this register value will be used for M47-M40 of the Maintenance frame, instead of register 0x57h. [AMM47:AMM40] = bits[7:0] of the KS8993F data byte if the Operating Mode in register 0x4Ah bits[1:0] is set to "10"	0
6	AMM46	R/W		0
5	AMM45	R/W		0
4	AMM44	R/W		0
3	AMM43	R/W		0
2	AMM42	R/W		0
1	AMM41	R/W		0
0	AMM40	R/W		0

Register 77 (0x4D): Valid MC Packet Transmitted Counter

Bit	Name	R/W	Description	Default
7	VMTX7	RO	At both the Center and Terminal sides, this counter is incremented when a valid maintenance packet is transmitted. 0000_0000 : No valid maintenance packet transmitted 0000_0001 : 1 valid maintenance packet transmitted : 1111_1111 : 255 valid maintenance packets transmitted This counter is cleared when 0x00h is written to reg. 0x44h.	0
6	VMTX6	RO		0
5	VMTX5	RO		0
4	VMTX4	RO		0
3	VMTX3	RO		0
2	VMTx2	RO		0
1	VMTX1	RO		0
0	VMTx0	RO		0

Register 78 (0x4E): Valid MC Packet Received Counter

Bit	Name	R/W	Description	Default
7	VMRX7	RO	At both the Center and Terminal sides, this counter is incremented when a valid maintenance packet (good CRC, valid OP code, valid direction) is received. 0000_0000 : No valid maintenance packet received 0000_0001 : 1 valid maintenance packet received : 1111_1111 : 255 valid maintenance packets received This counter is cleared when 0x00h is written to reg. 0x44h.	0
6	VMRX6	RO		0
5	VMRX5	RO		0
4	VMRX4	RO		0
3	VMRX3	RO		0
2	VMRX2	RO		0
1	VMRX1	RO		0
0	VMRX0	RO		0

Register 79 (0x4F): Shadow of 0x58h Register

Bit	Name	R/W	Description	Default
7-0	SHA7-0	RO	This register is shadow of 0x58h register when the OPT link is up.	0x07 (Terminal side) ----- 0x47 (Center side)

Register 80 (0x50): My Status 1 (Terminal and Center side)

Bit	Name	R/W	Description	Default
7	S7	RO	H-MC Link speed 1	0
6	S6	RO	H-MC Link Option 1 = Terminal MC mode 0 = Center MC mode	1 (Terminal side) 0 (Center side)
5	S5	RO	Loop back mode indication 1 = In loop back state (CST1, CST2, UST1) 0 = Normal	0
4	S4	R/W	Loss of optical signal notification 1 = use FEFI 0 = use maintenance frame (Center side - CPU will update this bit Terminal side - Hardware will update this bit based on external pin value)	0
3	S3	R/W	DIAG result 1 = Diagnostic Fail 0 = Normal operation (Center side - CPU will update this bit. Terminal side - This bit will be updated through DIAGF pin.)	DIAGF pin value DIAGF (Ipd)
2	S2	R/W	UTP Link Down 1 = link down 0 = link up (Center side - CPU will update this bit. Terminal side - This bit is read only and updated by hardware.)	1
1	S1	RO	SD disable 1 = abnormal (no optical signal detected) 0 = normal (optical signal detected)	1
0	S0	RO	Power down 1 = power down 0 = normal operation	Inverse of PDD# pin value PDD# (Ipu)

Register 81 (0x51): My Status 2

Bit	Name	R/W	Description	Default
7-4	S15 – S12	RO	Reserved	0
3	S11	R/W	Number of Physical interface making up the UTP link 0 = one 1 = greater than one	0
2	S10	R/W	For Terminal MC mode, this bit indicates the auto negotiation capability. For Center MC mode, this bit must always be "0". 1 = auto negotiation is supported 0 = auto negotiation is not supported	P2ANEN pin value (Terminal MC) ----- 0 (Center MC)
1	S9	RO	For Terminal MC mode, this bit indicates the UTP port's DUPLEX	0

			status. For Center MC mode, this bit is always "0". 1 = Full Duplex 0 = Half Duplex, or Register 0x50h bit[2] is "1" (UTP link is down)	
0	S8	RO	For Terminal MC mode, this bit indicates the UTP port's SPEED status. For Center MC mode, this bit is always "0". 1 = 100Mbps 0 = 10 Mbps, or Register 0x50h bit[2] is "1" (UTP link is down)	0

Register 82 (0x52): My Vendor Info (1)

Bit	Name	R/W	Description	Default
7-0	MM7–MM0	RW		0x00

Register 83 (0x53): My Vendor Info (2)

Bit	Name	R/W	Description	Default
7-0	MM15–MM8	RW		0x00

Register 84 (0x54): My Vendor Info (3)

Bit	Name	R/W	Description	Default
7-0	MM23–MM16	RW		0x00

Register 85 (0x55): My Model Info (1)

Bit	Name	R/W	Description	Default
7-0	MM31–MM24	RW	Note: If Remote Command feature is used, this register value can not be set to 0x22, 0x26, 0x2A and 0x2E. All other values are valid.	0x00

Register 86 (0x56): My Model Info (2)

Bit	Name	R/W	Description	Default
7-0	MM39–MM32	RW		0x00

Register 87 (0x57): My Model Info (3)

Bit	Name	R/W	Description	Default
7-0	MM47–MM40	RW		0x00

Register 88 (0x58): LNK Partner Status (1)

Bit	Name	R/W	Description	Default
7-0	LS7–LS0	RO	This register has the same bits descriptions as register 80 (0x50).	0x47 (Center side) 0x07 (Terminal side)

Register 89 (0x59): LNK Partner Status (2)

Bit	Name	R/W	Description	Default
7-0	LS15–LS8	RO	This register has the same bits descriptions as register 81 (0x51).	0x00

Register 90 (0x5A): LNK Partner Vendor Info (1)

Bit	Name	R/W	Description	Default
7-0	LM7–LM0	RO		0x00

Register 91 (0x5B): LNK Partner Vendor Info (2)

Bit	Name	R/W	Description	Default
7-0	LM15–LM8	RO		0x00

Register 92 (0x5C): LNK Partner Vendor Info (3)

Bit	Name	R/W	Description	Default
7-0	LM23–LM16	RO		0x00

Register 93 (0x5D): LNK Partner Model Info (1)

Bit	Name	R/W	Description	Default
7-0	LM31–LM24	RO		0x00

Register 94 (0x5E): LNK Partner Model Info (2)

Bit	Name	R/W	Description	Default
7-0	LM39–LM32	RO		0x00

Register 95 (0x5F): LNK Partner Model Info (3)

Bit	Name	R/W	Description	Default
7-0	LM47–LM40	RO		0x00

4.4 Advanced Control Registers

The IPv4 TOS priority control registers implement a fully decoded 64 bit DSCP (Differentiated Services Code Point) register used to determine priority from the 6 bit TOS field in the IP header. The most significant 6 bits of the TOS field are fully decoded into 64 possibilities, and the singular code that results is compared against the corresponding bit in the DSCP register. If the register bit is a 1, the priority is high; if it is a 0, the priority is low.

Register 96 (0x60): TOS Priority Control Register 0

Bit	Name	R/W	Description	Default
7-0	DSCP[63:56]	R/W		0000_0000

Register 97 (0x61): TOS Priority Control Register 1

Bit	Name	R/W	Description	Default
7-0	DSCP[55:48]	R/W		0000_0000

Register 98 (0x62): TOS Priority Control Register 2

Bit	Name	R/W	Description	Default
7-0	DSCP[47:40]	R/W		0000_0000

Register 99 (0x63): TOS Priority Control Register 3

Bit	Name	R/W	Description	Default
7-0	DSCP[39:32]	R/W		0000_0000

Register 100 (0x64): TOS Priority Control Register 4

Bit	Name	R/W	Description	Default
7-0	DSCP[31:24]	R/W		0000_0000

Register 101 (0x65): TOS Priority Control Register 5

Bit	Name	R/W	Description	Default
7-0	DSCP[23:16]	R/W		0000_0000

Register 102 (0x66): TOS Priority Control Register 6

Bit	Name	R/W	Description	Default
7-0	DSCP[15:8]	R/W		0000_0000

Register 103 (0x67): TOS Priority Control Register 7

Bit	Name	R/W	Description	Default
7-0	DSCP[7:0]	R/W		0000_0000

Registers 104 to 109 define the switching engine's MAC address. This 48-bit address is used as the source address for MAC pause control frames.

Register 104 (0x68): MAC Address Register 0

Bit	Name	R/W	Description	Default
7-0	MACA[47:40]	R/W		0x00

Register 105 (0x69): MAC Address Register 1

Bit	Name	R/W	Description	Default
7-0	MACA[39:32]	R/W		0x10

Register 106 (0x6A): MAC Address Register 2

Bit	Name	R/W	Description	Default
7-0	MACA[31:24]	R/W		0xA1

Register 107 (0x6B): MAC Address Register 3

Bit	Name	R/W	Description	Default
7-0	MACA[23:16]	R/W		0xFF

Register 108 (0x6C): MAC Address Register 4

Bit	Name	R/W	Description	Default
7-0	MACA[15:8]	R/W		0xFF

Register 109 (0x6D): MAC Address Register 5

Bit	Name	R/W	Description	Default
7-0	MACA[7:0]	R/W		0xFF

Use registers 110 and 111 to read or write data to the static MAC address table, VLAN table, dynamic MAC address table, or the MIB counters.

Register 110 (0x6E): Indirect Access Control 0

Bit	Name	R/W	Description	Default
7-5	Reserved	R/W	Reserved	000
4	Read High Write Low	R/W	= 1, read cycle = 0, write cycle	0
3-2	Table select	R/W	00 = static MAC address table selected 01 = VLAN table selected 10 = dynamic MAC address table selected 11 = MIB counter selected	00
1-0	Indirect address high	R/W	Bit [9-8] of indirect address	00

Register 111 (0x6F): Indirect Access Control 1

Bit	Name	R/W	Description	Default
7-0	Indirect address low	R/W	Bit [7-0] of indirect address	0000_0000

Note: A write to reg. 111 will actually trigger a command. Read or write access will be decided by bit 4 of reg. 110.

Register 112 (0x70): Indirect Data Register 8

Bit	Name	R/W	Description	Default
68-64	Indirect data	R/W	Bit 68-64 of indirect data	0_0000

Register 113 (0x71): Indirect Data Register 7

Bit	Name	R/W	Description	Default
63-56	Indirect data	R/W	Bit 63-56 of indirect data	0000_0000

Register 114 (0x72): Indirect Data Register 6

Bit	Name	R/W	Description	Default
55-48	Indirect data	R/W	Bit 55-48 of indirect data	0000_0000

Register 115 (0x73): Indirect Data Register 5

Bit	Name	R/W	Description	Default
47-40	Indirect data	R/W	Bit 47-40 of indirect data	0000_0000

Register 116 (0x74): Indirect Data Register 4

Bit	Name	R/W	Description	Default
39-32	Indirect data	R/W	Bit 39-32 of indirect data	0000_0000

Register 117 (0x75): Indirect Data Register 3

Bit	Name	R/W	Description	Default
31-24	Indirect data	R/W	Bit 31-24 of indirect data	0000_0000

Register 118 (0x76): Indirect Data Register 2

Bit	Name	R/W	Description	Default
23-16	Indirect data	R/W	Bit 23-16 of indirect data	0000_0000

Register 119 (0x77): Indirect Data Register 1

Bit	Name	R/W	Description	Default
15-8	Indirect data	R/W	Bit 15-8 of indirect data	0000_0000

Register 120 (0x78): Indirect Data Register 0

Bit	Name	R/W	Description	Default
7-0	Indirect data	R/W	Bit 7-0 of indirect data	0000_0000

**DO NOT WRITE/READ TO/FROM REGISTERS 121 TO 127. DOING SO MAY PREVENT PROPER OPERATION.
MICREL INTERNAL TESTING ONLY**

Register 121 (0x79): Digital Testing Status 0

Bit	Name	R/W	Description	Default
7-0	Factory testing	RO	Reserved Qm_split status	0x00

Register 122 (0x7A): Digital Testing Status 1

Bit	Name	R/W	Description	Default
-----	------	-----	-------------	---------

7-0	Factory testing	RO	Reserved Dbg[7:0]	0x00
-----	-----------------	----	----------------------	------

Register 123 (0x7B): Digital Testing Control 0

Bit	Name	R/W	Description	Default
7-0	Factory testing	R/W	Reserved Dbg[12:8]	0x00

Register 124 (0x7C): Digital Testing Control 1

Bit	Name	R/W	Description	Default
7-0	Factory testing	R/W	Reserved	0x00

Register 125 (0x7D): Analog Testing Control 0

Bit	Name	R/W	Description	Default
7-0	Factory testing	R/W	Reserved	0x00

Register 126 (0x7E): Analog Testing Control 1

Bit	Name	R/W	Description	Default
7-0	Factory testing	R/W	Reserved	0x00

Register 127 (0x7F): Analog Testing Status

Bit	Name	R/W	Description	Default
7-0	Factory testing	RO	Reserved	0x00

4.5 Static MAC Address Table

The KS8993F has both a static and a dynamic MAC address table. When a Destination Address (DA) look up is requested, both tables are searched to make a packet forwarding decision. When a Source Address (SA) look up is requested, only the dynamic table is searched for aging, migration and learning purposes. The static DA look up result will have precedence over the dynamic DA look up result. If there is a DA match in both tables, the result from the static table will be used. The static table can be accessed and controlled by an external processor via the SMI, SPI and I2C interfaces. The external processor performs all addition, modification and deletion of static MAC table entries. These entries in the static MAC table will not be aged out by the KS8993F.

Table 10: Format of Static MAC Table (8 entries)

Bit	Name	R/W	Description	Default
57-54	FID	R/W	Filter VLAN ID, representing one of the 16 active VLANs	0000
53	Use FID	R/W	= 1, use (FID+MAC) to look up in static table = 0, use MAC only to look up in static table	0
52	Override	R/W	= 1, override port setting "transmit enable=0" or "receive enable=0" setting. = 0, no override	0
51	Valid	R/W	= 1, this entry is valid, the look up result will be used = 0, this entry is not valid	0
50-48	Forwarding ports	R/W	These 3 bits control the forwarding port(s): 001, forward to port 1 010, forward to port 2 100, forward to port 3 011, forward to port 1 and port 2 110, forward to port 2 and port 3 101, forward to port 1 and port 3 111, broadcasting (excluding the ingress port)	000
47-0	MAC address	R/W	48 bits MAC Address	0x0000_0000_0000

Examples:**1) Static Address Table Read (read the 2nd entry)**

Write to reg. 110 with 0x10 (read static table selected)
 Write to reg. 111 with 0x01 (trigger the read operation)
 Then
 Read reg. 113 (57-56)
 Read reg. 114 (55-48)
 Read reg. 115 (47-40)
 Read reg. 116 (39-32)
 Read reg. 117 (31-24)
 Read reg. 118 (23-16)
 Read reg. 119 (15-8)
 Read reg. 120 (7-0)

2) Static Address Table Write (write the 8th entry)

Write reg. 113 (57-56)
 Write reg. 114 (55-48)
 Write reg. 115 (47-40)
 Write reg. 116 (39-32)
 Write reg. 117 (31-24)
 Write reg. 118 (23-16)
 Write reg. 119 (15-8)
 Write reg. 120 (7-0)
 Write to reg. 110 with 0x00 (write static table selected)
 Write to reg. 111 with 0x07 (trigger the write operation)

4.6 VLAN Table

VLAN table is used to do VLAN table look up. If 802.1Q VLAN mode is enabled (Register 5, Bit 7 = 1), this table will be used to retrieve the VLAN information that is associated with the ingress packet. This information includes FID (filter ID), VID (VLAN ID), and VLAN membership as described below:

Table 11: Format of Static VLAN Table (16 entries)

Bit	Name	R/W	Description	Default
19	Valid	R/W	= 1, the entry is valid = 0, entry is invalid	1
18-16	Membership	R/W	Specify which ports are members of the VLAN. If a DA look up fails (no match in both static and dynamic tables), the packet associated with this VLAN will be forwarded to ports specified in this field. E.g. 101 means port 3 and 1 are in this VLAN.	111
15-12	FID	R/W	Filter ID. KS8993F supports 16 active VLANs represented by these four bit fields. FID is the mapped ID. If 802.1Q VLAN is enabled, the look up will be based on FID+DA and FID+SA.	0x0
11-0	VID	R/W	IEEE 802.1Q 12 bits VLAN ID	0x001

If 802.1Q VLAN mode is enabled, KS8993F will assign a VID to every ingress packet. If the packet is untagged or tagged with a null VID, the packet is assigned with the default port VID of the ingress port. If the packet is tagged with non null VID, the VID in the tag will be used. The look up process will start from the VLAN table look up. If the VID is not valid, the packet will be dropped and no address learning will take place. If the VID is valid, the FID is retrieved. The FID+DA and FID+SA lookups are performed. The FID+DA look up determines the forwarding ports. If FID+DA fails, the packet will be broadcast to all the members (excluding the ingress port) of the VLAN. If FID+SA fails, the FID+SA will be learned.

Examples:

1) VLAN Table Read (read the 3rd entry)

Write to reg. 110 with 0x14 (read VLAN table selected)
Write to reg. 111 with 0x02 (trigger the read operation)
Then
Read reg. 118 (VLAN table bits 19-16)
Read reg. 119 (VLAN table bits 15-8)
Read reg. 120 (VLAN table bits 7-0)

2) VLAN Table Write (write the 7th entry)

Write to reg. 118 (VLAN table bits 19-16)
Write to reg. 119 (VLAN table bits 15-8)
Write to reg. 120 (VLAN table bits 7-0)
Write to reg. 110 with 0x04 (write VLAN table selected)
Write to reg. 111 with 0x06 (trigger the write operation)

4.7 Dynamic MAC Address Table

This table is read only. The table contents are maintained by KS8993F only.

Table 12: Format of Dynamic MAC Table (1K entries)

Bit	Name	R/W	Description	Default
71	Data not ready	RO	= 1, entry is not ready, retry until this bit is set to 0 = 0, entry is ready	
70-67	Reserved	RO	Reserved	
66	MAC empty	RO	= 1, there is no valid entry in the table = 0, there are valid entries in the table	1
65-56	No of valid entries	RO	Indicates how many valid entries in the table 0x3ff means 1 K entries 0x001 means 2 entries 0x000 and bit 66 = 0 means 1 entry 0x000 and bit 66 = 1 means 0 entry	00_0000_0000
55-54	Time Stamp	RO	2 bits counter for internal aging	
53-52	Source port	RO	The source port where FID+MAC is learned 00, port 1 01, port 2 10, port 3	00
51-48	FID	RO	Filter ID	0x0
47-0	MAC Address	RO	48 bits MAC address	0x0000_0000_0000

Example:**Dynamic MAC Address Table Read (read the 1st entry and retrieve the MAC Table size)**

Write to reg. 110 with 0x18 (read dynamic table selected)

Write to reg. 111 with 0x00 (trigger the read operation)

Then

Read reg. 112 (71-64) // if bit 71 = 1, restart (reread) from this register

Read reg. 113 (63-56)

Read reg. 114 (55-48)

Read reg. 115 (47-40)

Read reg. 116 (39-32)

Read reg. 117 (31-24)

Read reg. 118 (23-16)

Read reg. 119 (15-8)

Read reg. 120 (7-0)

4.8 MIB (Management Information Base) Counters

The KS8993F provides 34 MIB counters per port. These counters are used to monitor the port activity for network management. The MIB counters have two format groups: "Per Port" and "All Port Dropped Packet".

Table 13: Format of "Per Port" MIB Counters

Bit	Name	R/W	Description	Default
31	Reserve	RO	Reserve	0
30	Count Valid	RO	= 1, Counter value is valid = 0, Counter value is not valid	0
29-0	Counter Values	RO	Counter value	0

"Per Port" MIB Counters are read using indirect memory access. The base address offsets and address ranges for all three ports are:

Port 1 : base is 0x00 and range is (0x00-0x1f)

Port 2 : base is 0x20 and range is (0x20-0x3f)

Port 3 : base is 0x40 and range is (0x40-0x5f)

Port 1's "Per Port" MIB Counters Indirect Memory Offsets are shown in the following table:

Table 14: Port 1's "Per Port" MIB Counters Indirect Memory Offsets

Offset	Counter Name	Description
0x0	RxLoPriorityByte	Rx lo-priority (default) octet count including bad packets
0x1	RxHiPriorityByte	Rx hi-priority octet count including bad packets
0x2	RxUndersizePkt	Rx undersize packets w/ good CRC
0x3	RxFragments	Rx fragment packets w/ bad CRC, symbol errors or alignment errors
0x4	RxOversize	Rx oversize packets w/ good CRC (max: 1536 or 1522 bytes)
0x5	RxJabbers	Rx packets longer than 1522 bytes w/ either CRC errors, Alignment errors, or symbol errors. (Depends on max packet size setting).
0x6	RxSymbolError	Rx packets w/ invalid data symbol and legal packet size.
0x7	RxCRCError	Rx packets within (64,1522) bytes w/ an integral number of bytes and a bad CRC (Upper limit depends on max packet size setting).
0x8	RxAlignmentError	Rx packets within (64,1522) bytes w/ a non-integral number of bytes and a bad CRC (Upper limit depends on max packet size setting).
0x9	RxControl8808Pkts	The number of MAC control frames received by a port with 88-08h in EtherType field.
0xA	RxPausePkts	The number of PAUSE frames received by a port. PAUSE

		frame is qualified with EtherType (88-08h), DA, control opcode (00-01), data length (64B min), and a valid CRC
0xB	RxBroadcast	Rx good broadcast packets (not including error broadcast packets or valid multicast packets)
0xC	RxMulticast	Rx good multicast packets (not including MAC control frames, error multicast packets or valid broadcast packets)
0xD	RxUnicast	Rx good unicast packets
0xE	Rx64Octets	Total Rx packets (bad packets included) that were 64 octets in length
0xF	Rx65to127Octets	Total Rx packets (bad packets included) that are between 65 and 127 octets in length
0x10	Rx128to255Octets	Total Rx packets (bad packets included) that are between 128 and 255 octets in length
0x11	Rx256to511Octets	Total Rx packets (bad packets included) that are between 256 and 511 octets in length
0x12	Rx512to1023Octets	Total Rx packets (bad packets included) that are between 512 and 1023 octets in length
0x13	Rx1024to1522Octets	Total Rx packets (bad packets included) that are between 1024 and 1522 octets in length (Upper limit depends on max packet size setting).
0x14	TxLoPriorityByte	Tx lo-priority good octet count, including PAUSE packets
0x15	TxHiPriorityByte	Tx hi-priority good octet count, including PAUSE packets
0x16	TxLateCollision	The number of times a collision is detected later than 512 bit-times into the Tx of a packet.
0x17	TxPausePkts	The number of PAUSE frames transmitted by a port
0x18	TxBroadcastPkts	Tx good broadcast packets (not including error broadcast or valid multicast packets)
0x19	TxMulticastPkts	Tx good multicast packets (not including error multicast packets or valid broadcast packets)
0x1A	TxUnicastPkts	Tx good unicast packets
0x1B	TxDeferred	Tx packets by a port for which the 1st Tx attempt is delayed due to the busy medium
0x1C	TxTotalCollision	Tx total collision, half duplex only
0x1D	TxExcessiveCollision	A count of frames for which Tx fails due to excessive collisions

0x1E	TxSingleCollision	Successfully Tx frames on a port for which Tx is inhibited by exactly one collision
0x1F	TxMultipleCollision	Successfully Tx frames on a port for which Tx is inhibited by more than one collision

Table 15: Format of "All Port Dropped Packet" MIB Counters

Bit	Name	R/W	Description	Default
30-16	Reserved	N/A	Reserved	N/A
15-0	Counter values	RO	Counter value	0

"All Port Dropped Packet" MIB Counters are read using indirect memory access. The address offsets for these counters are shown in the following table:

Table 16: "All Port Dropped Packet" MIB Counters Indirect Memory Offsets

Offset	Counter Name	Description
0x100	Port1 TX Drop Packets	TX packets dropped due to lack of resources
0x101	Port2 TX Drop Packets	TX packets dropped due to lack of resources
0x102	Port3 TX Drop Packets	TX packets dropped due to lack of resources
0x103	Port1 RX Drop Packets	RX packets dropped due to lack of resources
0x104	Port2 RX Drop Packets	RX packets dropped due to lack of resources
0x105	Port3 RX Drop Packets	RX packets dropped due to lack of resources

Examples:

1) MIB counter read (read port 1 "Rx64Octets" counter)

Write to reg. 110 with 0x1c (read MIB counters selected)

Write to reg. 111 with 0x0e (trigger the read operation)

Then

Read reg. 117 (counter value 30-24) // If bit 30 = 0, restart (reread) from this register

Read reg. 118 (counter value 23-16)

Read reg. 119 (counter value 15-8)

Read reg. 120 (counter value 7-0)

2) MIB counter read (read port 2 "Rx64Octets" counter)

Write to reg. 110 with 0x1c (read MIB counter selected)

Write to reg. 111 with 0x2e (trigger the read operation)

Then

Read reg. 117 (counter value 30-24) // If bit 30 = 0, restart (reread) from this register

Read reg. 118 (counter value 23-16)

Read reg. 119 (counter value 15-8)

Read reg. 120 (counter value 7-0)

3) MIB counter read (read "Port1 TX Drop Packets" counter)

Write to reg. 110 with 0x1d (read MIB counter selected)
Write to reg. 111 with 0x00 (trigger the read operation)
Then
Read reg. 119 (counter value 15-8)
Read reg. 120 (counter value 7-0)

NOTES:

1. Both “Per Port” and “All Port Dropped Packet” MIB Counters do not indicate overflow. The application must keep track of overflow conditions for these counters.
2. “All Port Dropped Packet” MIB Counters do not indicate if count is valid. The application must keep track of valid conditions for these counters.
3. To read out all the counters, the best performance over the SPI bus is $(160+3)*8*200 = 260$ ms, where there are 160 registers, 3 overheads, 8 clocks per access, **at 5 MHz**. In the heaviest condition, the counters will overflow in 2 minutes. It is recommended that the software read all the counters at least every 30 seconds.
4. A high performance SPI master is recommended to prevent counters overflow.
5. “Per Port” MIB Counters are designed as “read clear”. These counters will be cleared after they are read.
6. “All Port Dropped Packet” MIB counters are not cleared after they are read.

5 Electrical Specifications

Stresses greater than those listed in this table may cause permanent damage to the device. Operation of the device at these or any other conditions above those specified in the operating sections of this specification is not implied. Maximum conditions for extended periods may affect reliability. Unused inputs must always be tied to an appropriate logic voltage level.

5.1 Absolute Maximum Ratings

Storage Temperature (T_S) -55°C to +150°C
 Supply Voltages VDDA, VDDAP,
 VDDC -0.5V to +2.4 V
 Supply Voltages VDDATX, VDDARX,
 VDDIO -0.5V to +4.0 V
 All Inputs -0.5V to +4.0 V
 All Outputs -0.5V to +4.0 V

5.2 Recommended Operating Conditions

Parameter	Symbol	Min	Typ	Max	Unit
Supply Voltages	VDDA, VDDAP, VDDC	1.710	1.8	1.890	V
	VDDATX, VDDARX, VDDIO	3.135	3.3	3.465	V
Ambient Operating Temperature	T_A	0		70	°C
Maximum Junction Temperature	T_J			125	°C
Thermal Resistance Junction to Ambient	θ_{JA}		32		°C/W

5.3 Electrical Characteristics

Parameter	Sym	Test Condition	Min	Typ	Max	Unit
Supply Current (including TX output driver current for KS8993F device only)						
		100BASE-TX operation (total)				A
100BASE-TX	I_{dd}	VDDA, VDDAP, VDDC = 1.8V VDDATX, VDDARX, VDDIO = 3.3V		0.10 0.16		A
		10BASE-T operation (total)				A
10BASE-T	I_{dd}	VDDA, VDDAP, VDDC = 1.8V VDDATX, VDDARX, VDDIO = 3.3V		0.07 0.19		A
100BASE-TX (analog)	I_{da}			TBD		A
100BASE-TX (digital)	I_{dd}			TBD		A
10BASE-T(analog)	I_{dx}			TBD		A
10BASE-T(digital)	I_{dx}			TBD		A
TTL Inputs						
Input High Voltage	V_{ih}		2.0			V
Input Low Voltage	V_{il}				0.8	V
Input Current	I_{in}	$V_{in} = GND \sim VDDIO$	-10		10	μA
TTL Outputs						
Output High Voltage	V_{oh}	$I_{oh} = -4 \text{ mA}$	2.4			V
Output Low Voltage	V_{ol}	$I_{ol} = 4 \text{ mA}$			0.4	V
Output Tri-state Leakage	$ I_{oz} $				10	μA
100BASE-TX Transmit (measured differentially after 1:1 transformer)						
Peak Differential Output Voltage	V_o	100 Ω termination on the differential output.	0.95		1.05	V
Output Voltage Imbalance	V_{imb}	100 Ω termination on the differential output			2	%
Rise/Fall time	T_r/T_f		3		5	ns
Rise/Fall time Imbalance			0		0.5	ns
100BASE-TX Transmit (measured differentially after 1:1 transformer)						
Duty Cycle Distortion					0.5	ns
Overshoot					5	%
Reference Voltage of ISET	V_{set}			0.5		V
Output Jitters		Peak to peak		0.7	1.4	ns
10BASE-T Receive						
Squelch Threshold	V_{sq}	5 MHz square wave		400		mV

10BASE-T Transmit (measured differentially after 1:1 transformer)

Peak Differential Output Voltage	V_p	100 Ω termination on the differential output.		2.3		V
Jitters Added		100 Ω termination on the differential output.			± 8	ns
Rise/Fall time				25		ns

5.4 100BASE-FX Electrical Specification

Parameter	Sym	Test Condition	Min	Typ	Max	Unit
-----------	-----	----------------	-----	-----	-----	------

Supply Current (including FX output driver current)

	100BASE-FX operation - total			TBD		A
100BASE-FX (transmitter)	I_{dx}			TBD		A
100BASE-FX (analog)	I_{da}			TBD		A
100BASE-FX (digital)	I_{dd}			TBD		A

100BASE-FX Transmit

Peak Differential Output Voltage	V_o	100 Ω termination on the differential output.	0.95		1.05	V
Output Voltage Imbalance	V_{imb}	100 Ω termination on the differential output			2	%
Rise/Fall time	T_r/T_f		3		5	ns
Rise/Fall time Imbalance			0		0.5	ns

Fiber Detection Pin (FXSD)

Fiber turn on	Fxon	100BASE-FX mode	1.0		1.8	V
Fiber signal detect	Fxsd	100BASE-FX mode	2.2			V

6 Timing Specifications

6.1 EEPROM Timing

Figure 12: EEPROM Interface Input Timing Diagram

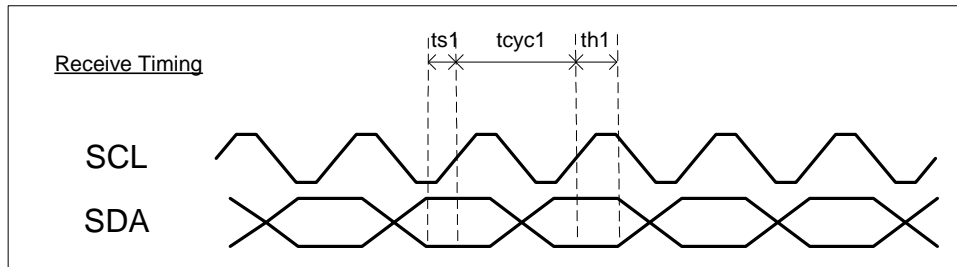

Figure 13: EEPROM Interface Output Timing Diagram

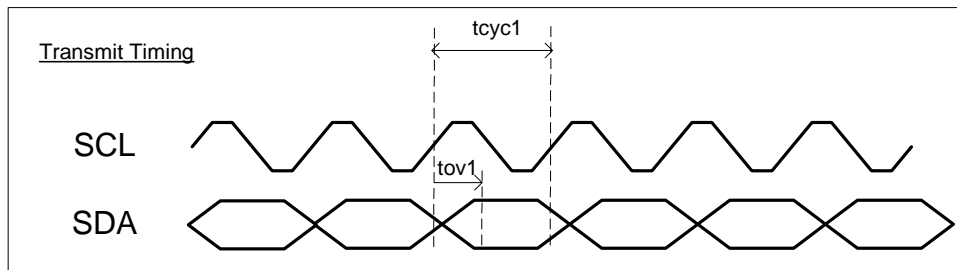

Table 17: EEPROM Timing Parameters

Timing Parameter	Description	Min	Typ	Max	Unit
tcyc1	Clock cycle		16384		ns
ts1	Setup time	20			ns
th1	Hold time	20			ns
tov1	Output Valid	4096	4112	4128	ns

6.2 SNI Timing

Figure 14: SNI Input Timing Diagram

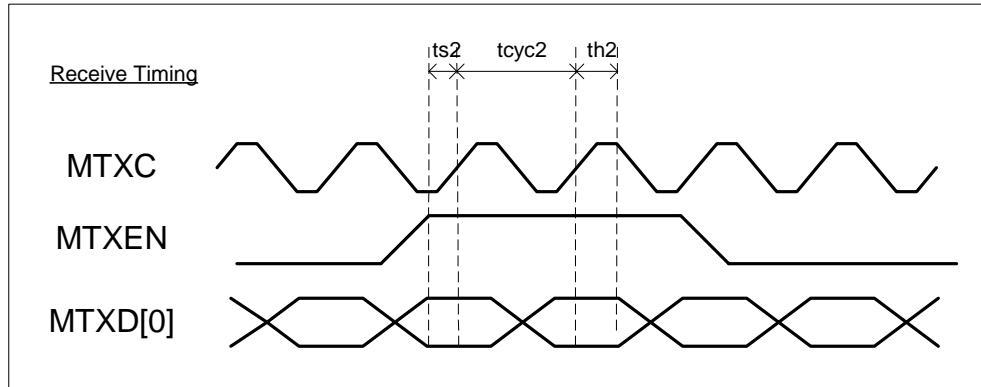

Figure 15: SNI Output Timing Diagram

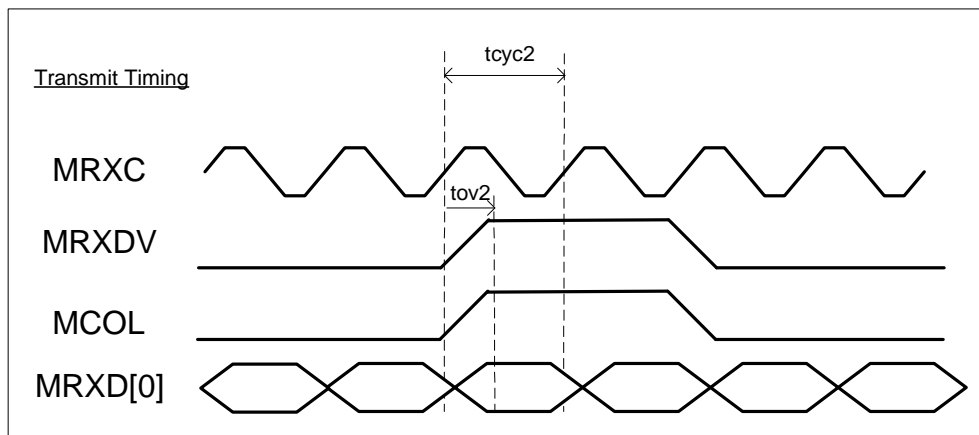

Table 18: SNI Timing Parameters

Timing Parameter	Description	Min	Typ	Max	Unit
tcyc2	Clock cycle		100		ns
ts2	Setup time	10			ns
th2	Hold time	0			ns
tov2	Output Valid	0	3	6	ns

6.3 MII Timing

6.3.1 MAC Mode MII Timing

Figure 16: MAC Mode MII Timing - Data received from MII

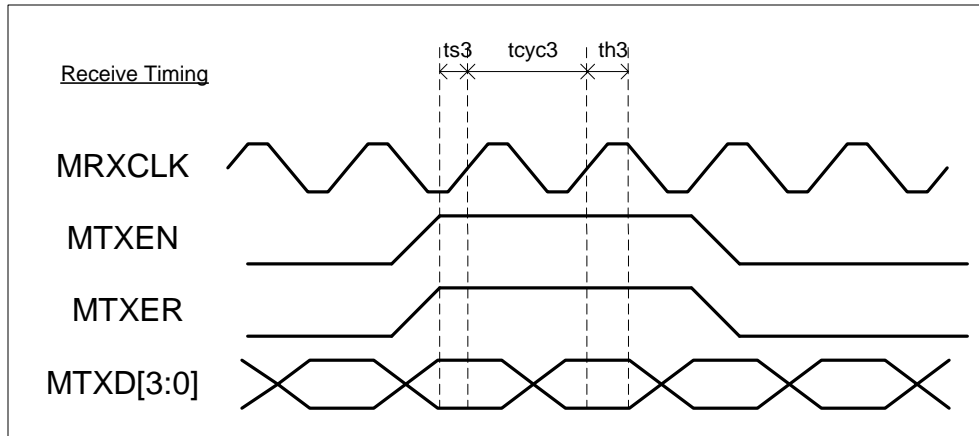

Figure 17: MAC Mode MII Timing - Data transmitted to MII

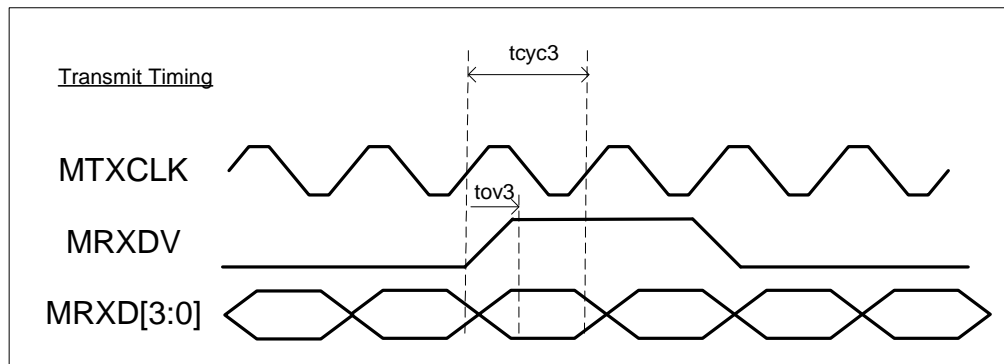

Table 19: MAC mode MII Timing Parameters

Timing Parameter	Description	Min	Typ	Max	Unit
tcyc3 (100BASE-TX)	Clock cycle 100BASE-TX		40		ns
tcyc3 (10BASE-T)	Clock cycle 10BASE-T		400		ns
ts3	Setup time	10			ns
th3	Hold time	5			ns
tov3	Output Valid	7	11	16	ns

6.3.2 PHY Mode MII Timing

Figure 18: PHY Mode MII Timing – Data received from MII

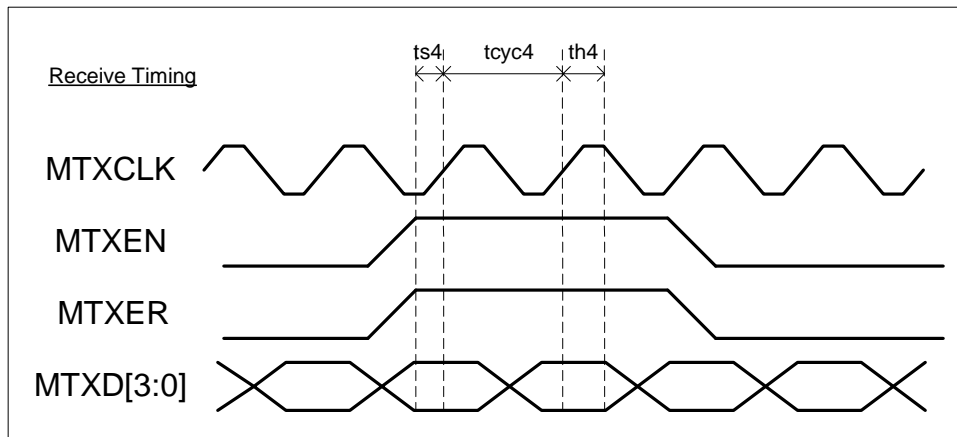

Figure 19: PHY Mode MII Timing - Data transmitted to MII

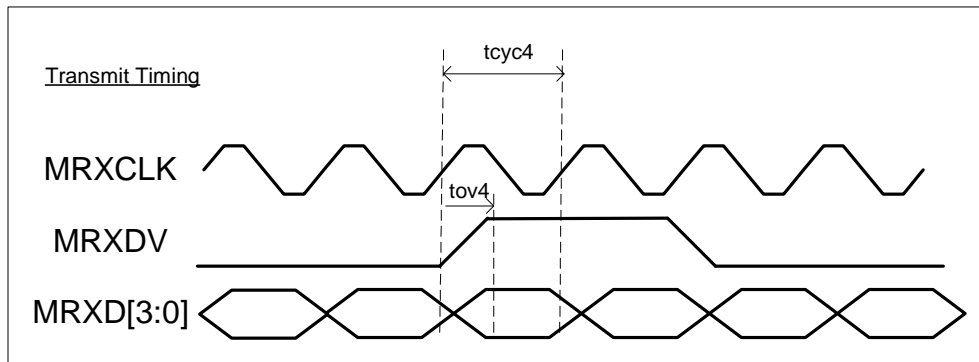

Table 20: PHY Mode MII Timing Parameters

Timing Parameter	Description	Min	Typ	Max	Unit
tcyc4 (100BASE-TX)	Clock cycle 100BASE-TX		40		ns
tcyc4 (10BASE-T)	Clock cycle 10BASE-T		400		ns
ts4	Setup time	10			ns
th4	Hold time	0			ns
tov4	Output Valid	18	25	28	ns

6.3.3 SPI Timing

Figure 20: SPI Input Timing

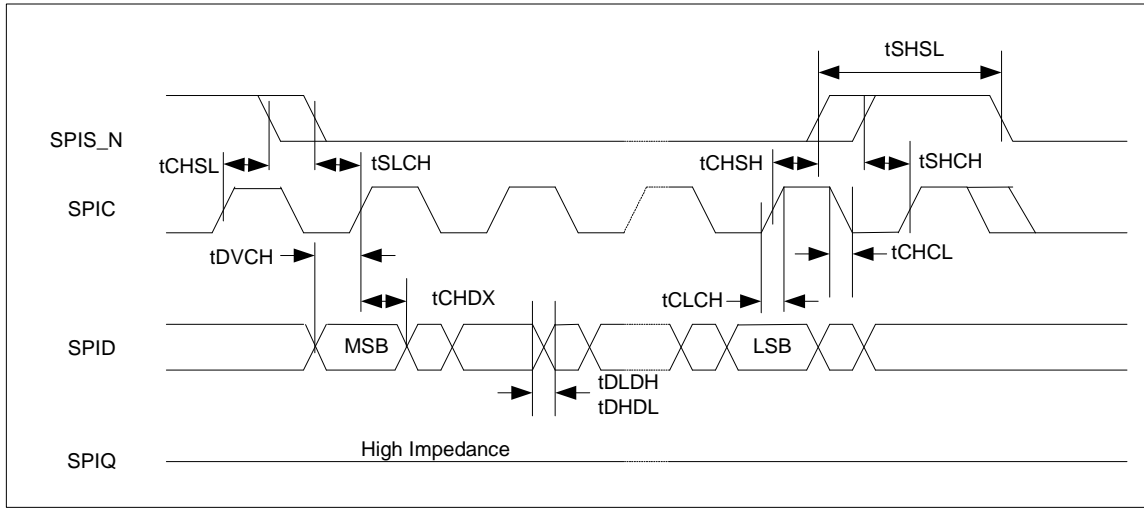

Table 21: SPI Input Timing Parameters

Timing Parameter	Description	Min	Max	Units
fC	Clock Frequency		5	MHz
tCHSL	SPIS_N Inactive Hold Time	90		ns
tSLCH	SPIS_N Active Setup Time	90		ns
tCHSH	SPIS_N Active Hold Time	90		ns
tSHCH	SPIS_N Inactive Setup Time	90		ns
tSHSL	SPIS_N Deselect Time	100		ns
tDVCH	Data Input Setup Time	20		ns
tCHDX	Data Input Hold Time	30		ns
tCLCH	Clock Rise Time		1	us
tCHCL	Clock Fall Time		1	us
tDLDH	Data Input Rise Time		1	us
tDHDL	Data Input Fall Time		1	us

Figure 21: SPI Output Timing

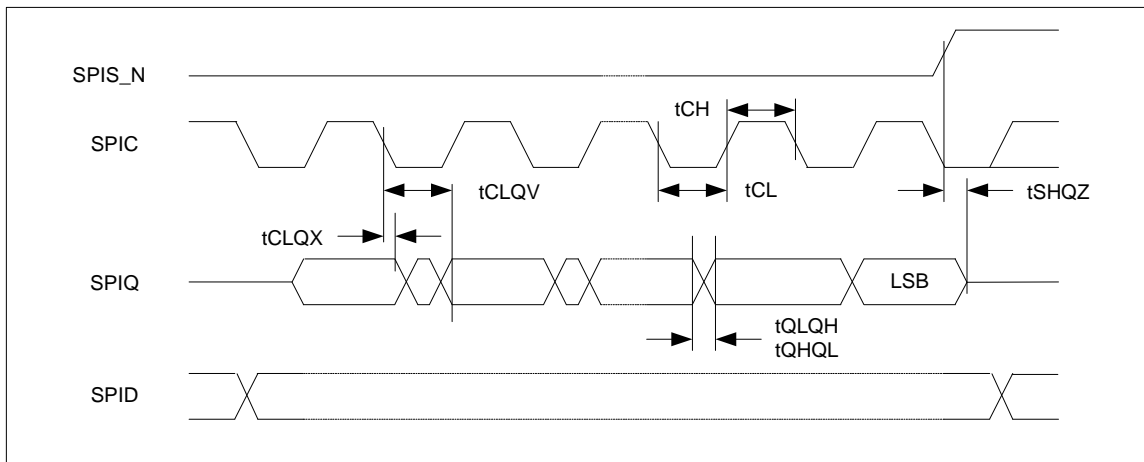
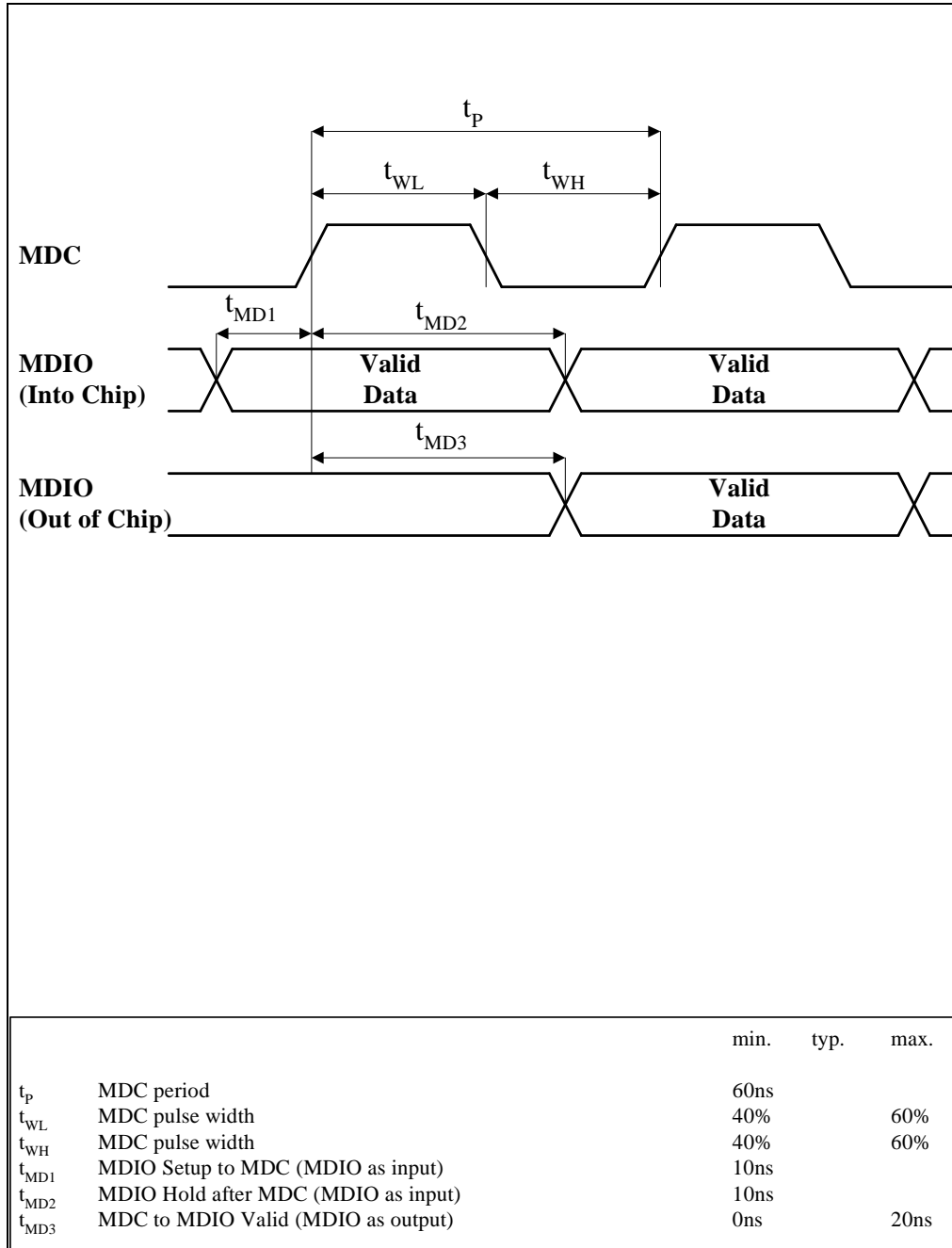

Table 22: SPI Output Timing Parameters

Timing Parameter	Description	Min	Max	Units
fC	Clock Frequency		5	MHz
tCLQX	SPIQ Hold Time	0	0	ns
tCLQV	Clock Low to SPIQ Valid		60	ns
tCH	Clock High Time	90		ns
tCL	Clock Low Time	90		
tQLQH	SPIQ Rise Time		50	ns
tQHQL	SPIQ Fall Time		50	ns
tSHQZ	SPIQ Disable Time		100	ns

6.3.4 MDC/MDIO Timing

Figure 22: MDC/MDIO Timing for MIIM and SMI Interfaces



6.3.5 Auto Negotiation Timing

Figure 23: Auto Negotiation Timing

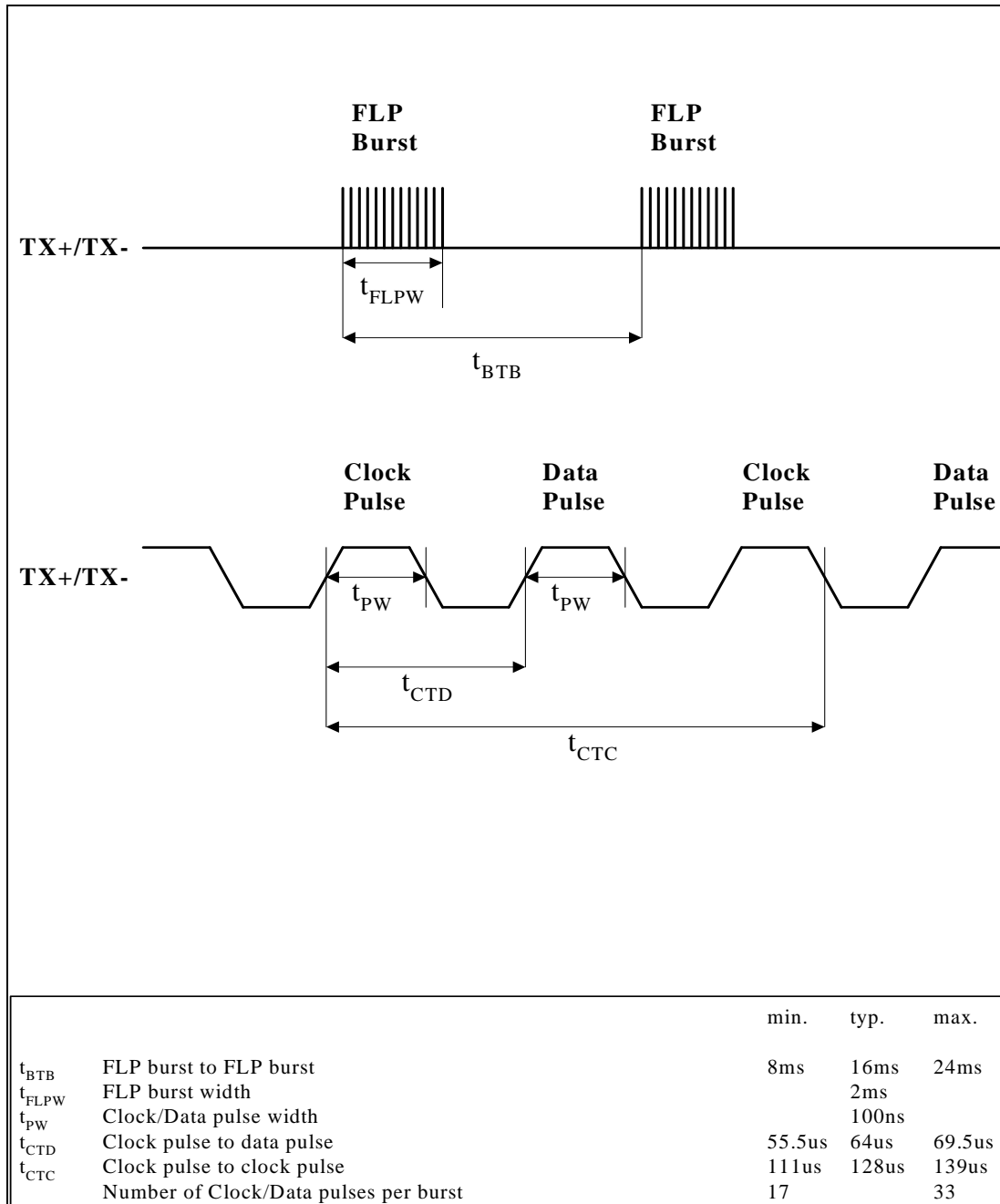

6.4 Reset Timing

The KS8993F should be powered up with the VDD core voltages applied before the VDDIO voltage. In the worst case, both VDD core and VDDIO voltages can be applied simultaneously.

Additional, reset timing requirement are summarized in the following figure and table.

Figure 24: Reset Timing

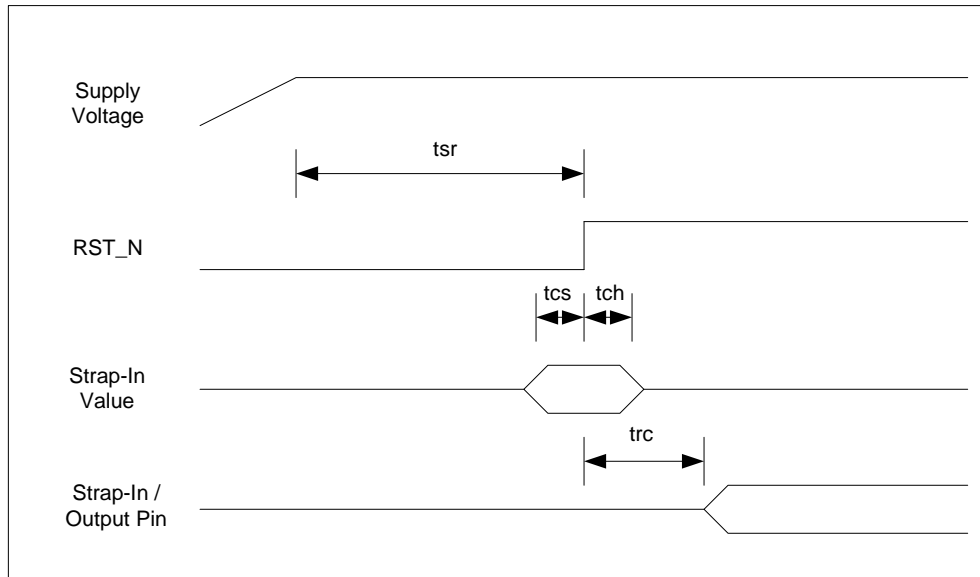

Table 23: Reset Timing Parameters

Parameter	Description	Min	Max	Units
t_{sr}	Stable supply voltages to reset high	10		ms
t_{cs}	Configuration setup time	50		ns
t_{ch}	Configuration hold time	50		ns
t_{rc}	Reset to Strap-In pin output	50		us

After the de-assertion of reset, it is recommended to wait a minimum of 100 us before starting programming on the managed interface (I2C slave, SPI slave, SMI, MIIM).

6.5 Reset Circuit

The reset circuit in Figure 25 is recommended for powering up the KS8993F if reset is triggered only by the power supply.

Figure 25: Recommended Reset Circuit

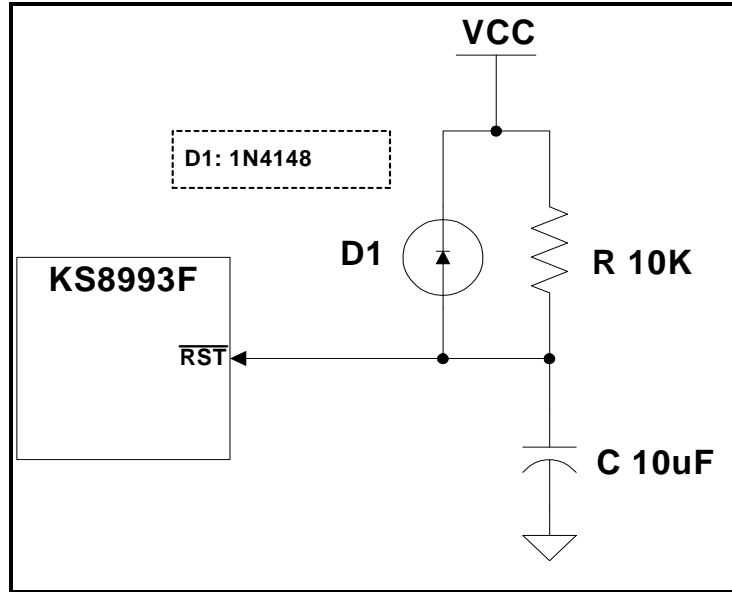

The reset circuit in Figure 26 is recommended for applications where reset is driven by another device (e.g., CPU, FPGA, etc). At power-on-reset, R, C and D1 provide the necessary ramp rise time to reset the KS8993F device. The RST_OUT_n from CPU/FPGA provides the warm reset after power up.

Figure 26: Recommended Reset Circuit for interfacing with CPU/FPGA Reset Output

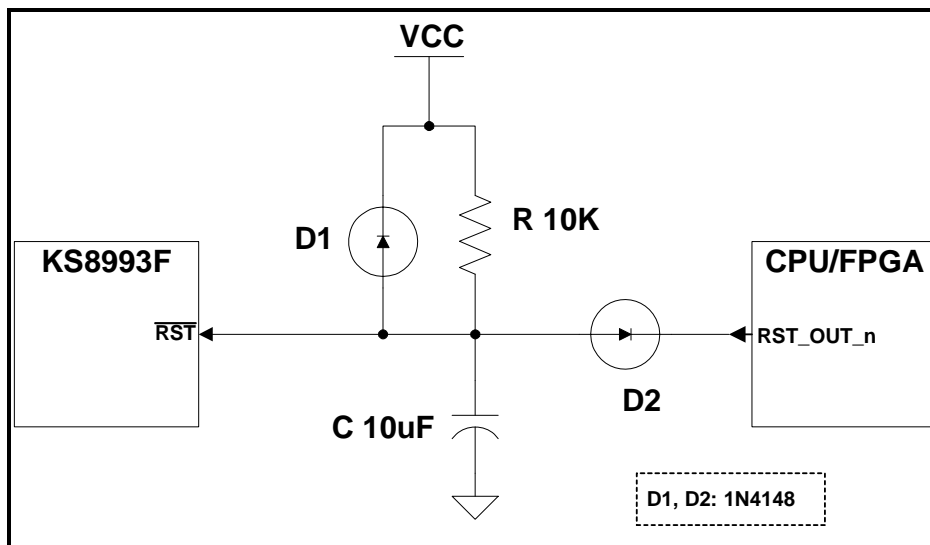

7 Selection of Isolation Transformer

An 1:1 isolation transformer is required at the line interface. An isolation transformer with integrated common-mode choke is recommended for exceeding FCC requirements. The following table gives recommended transformer characteristics.

Table 24: Transformer Selection Criteria

Parameter	Value	Test Condition
Turns Ratio	1 CT : 1 CT	
Open-Circuit Inductance (min.)	350 uH	100 mV, 100 kHz, 8 mA
Leakage Inductance (max.)	0.4 uH	1 MHz (min.)
Inter-Winding Capacitance (max.)	12 pF	
D.C. Resistance (max.)	0.9 Ohms	
Insertion Loss (max.)	1.0 dB	0-65 MHz
HIPOT (min.)	1500 Vrms	

The following are recommended transformers for the KS8993F.

Table 25: Qualified Single Port Magnetic

Magnetic Manufacturer	Part Number	Auto MDI-X
Pulse	H1102	Yes
Pulse (low cost)	H1260	Yes
Transpower	HB726	Yes
Bel Fuse	S558-5999-U7	Yes
Delta	LF8505	Yes
LanKom	LF-H41S	Yes

8 Selection of Crystal/Oscillator

A crystal or oscillator with the following typical characteristics is recommended.

Table 26: Crystal/Oscillator Selection Criteria

Charateristics	Value	Units
Frequency	25.00000	MHz
Frequency Tolerance (max)	±50	ppm
Load Capacitance (max)	20	pF
Series Resistance	25	Ω

9 Package Information

Figure 27: 128-pin PQFP Package Outline Drawing

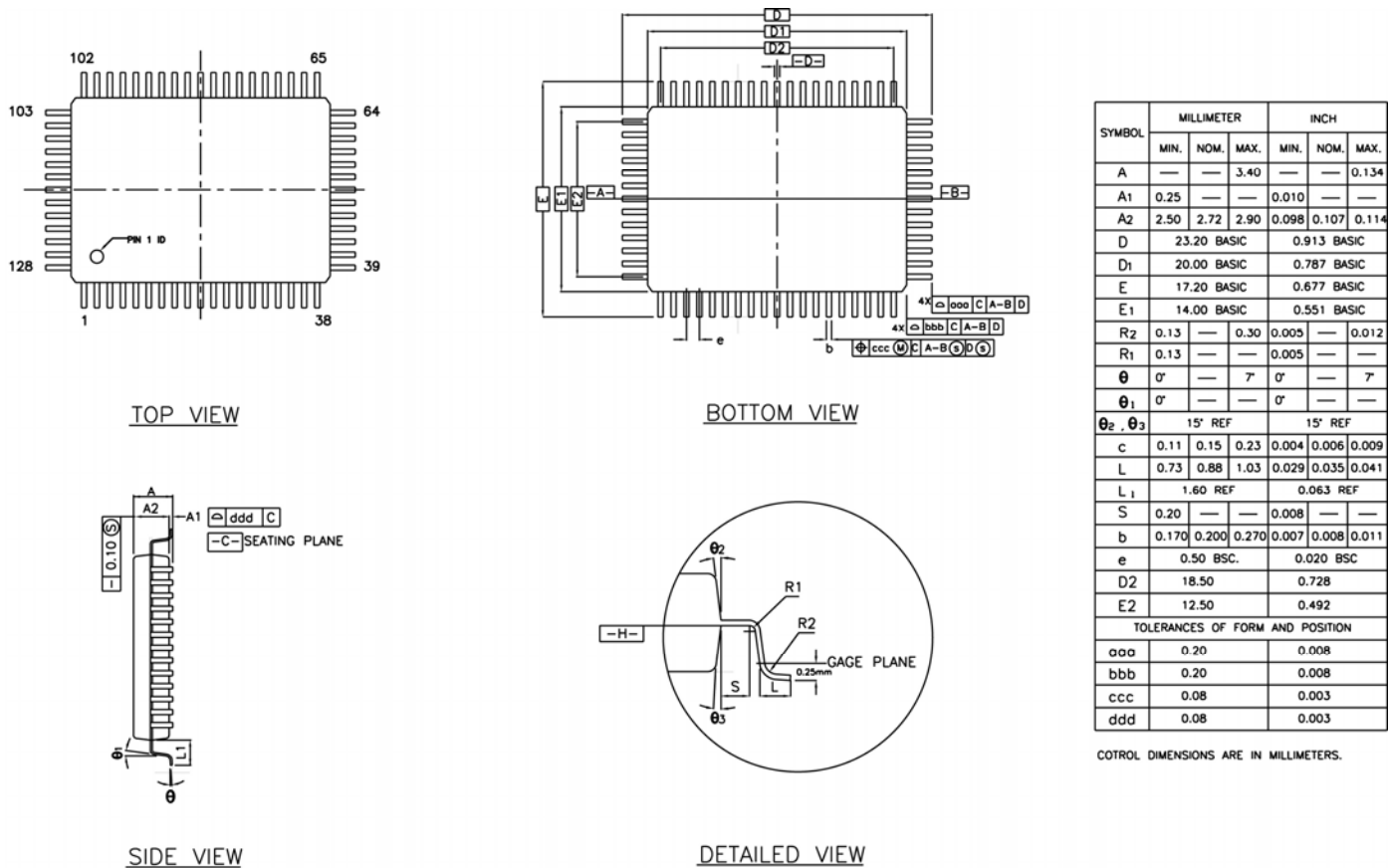

NOTES :

1. DIMENSION D1 AND E1 DO NOT INCLUDE MOLD PROTRUSION. ALLOWABLE PROTRUSION IS 0.25mm PER SIDE. DIMENSIONS D1 AND E1 DO INCLUDE MOLD MISMATCH AND ARE DETERMINED AT DATUM PLANE \perp -H-
2. DIMENSION b DOES NOT INCLUDE DAMBAR PROTRUSION. ALLOWABLE DAMBAR PROTRUSION SHALL BE 0.08mm TOTAL IN EXCESS OF THE b DIMENSION AT MAXIMUM MATERIAL CONDITION. DAMBAR CANNOT BE LOCATED ON THE LOWER RADIUS OR THE LEAD FOOT.
3. THE DIAGRAMS DO NOT REPRESNET THE ACTUAL PIN COUNT.

MICREL, INC. 2180 FORTUNE DRIVE SAN JOSE, CA 95131 USA
 TEL +1 (408) 944-0800 FAX +1 (408) 474-1000 WEB <http://www.micrel.com>



The information furnished by Micrel in this data sheet is believed to be accurate and reliable. However, no responsibility is assumed by Micrel for its use. Micrel reserves the right to change circuitry and specifications at any time without notification to the customer.

Micrel Products are not designed or authorized for use as components in life support appliances, devices or systems where malfunction of a product can reasonably be expected to result in personal injury. Life support devices or systems are devices or systems that (a) are intended for surgical implant into the body or (b) support or sustain life, and whose failure to perform can be reasonably expected to result in a significant injury to the user. A Purchaser's use or sale of Micrel Products for use in life support appliances, devices or systems is a Purchaser's own risk and Purchaser agrees to fully indemnify Micrel for any damages resulting from such use or sale.

© 2006 Micrel, Incorporated.

Looking for pricing, stock, or lifecycle information?

Click below to explore more details on WIN SOURCE:

-  [View KS8993FL on WIN SOURCE](#)
-  [Microchip Technology](#) Information

Optimize Your Supply Chain with WIN SOURCE Solutions

-  Global Sourcing Solution
-  Obsolete Management
-  Cost Control Management
-  Shortage Management
-  Alternative Solution
-  Excess Inventory Management