



THE DATASHEET OF KNH21C105DA3TS



PUBLICATION No.

Reference

Messrs. Digi-key

EMI FILTER Specification

Part No. :KNH21 Series

RoHS Compliant

19.Aug., 2011

Approved by Masanori Somazu

Checked by Kazuaki Higashi

Checked by Kazuki Shimizu

Issued by Takafumi Nogi

EMI FILTER SPECIFICATION

1. Apply

This specification applies to Kyocera chip EMI filter KNH21 Series.

2. Nomenclature

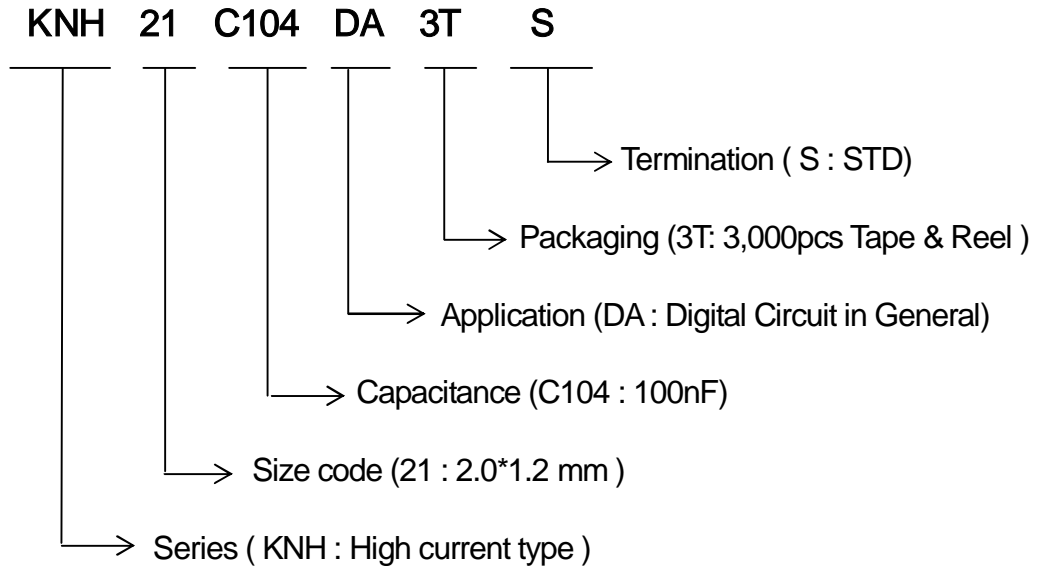

3. Performance / Requirement

3-1 Standard requirement

A: Insulation resistance Min. 500 (M ohm)
 B: Operating temperature -40 to 85 (deg.)

3-2 Electrical characteristics

Parts Number	Capacitance (+50 / -20 %) (pF)	Rated current (A)	Rated voltage (V)	Direct - current resistance (Ohm)
KNH21C221DA3TS	220	1.0	50	Max. 0.08
KNH21C471DA3TS	470	1.0	50	Max. 0.08
KNH21C473DA3TS	47,000	2.0	50	Max. 0.02
KNH21C104DA3TS	100,000	2.0	25	Max. 0.02
KNH21C105DA3TS	1,000,000	4.0	10	Max. 0.02
KNH21C475DA3TS	4,700,000	4.0	6.3	Max. 0.02
KNH21C106DA3TS	10,000,000	6.0	6.3	Max. 0.01

3-3 Frequency Characteristics

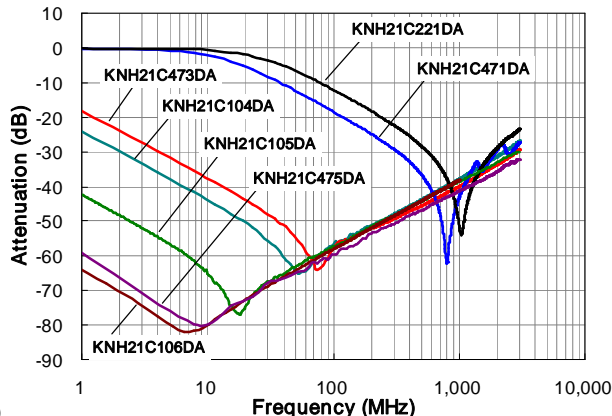

4. Size and dimensions

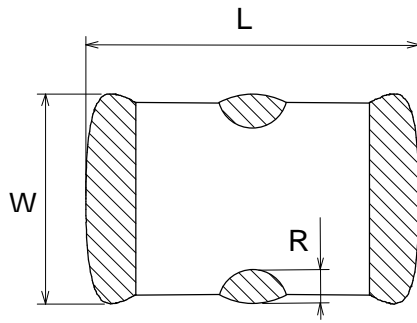

Unit : mm

Symbol	Dimensions
L	2.00 +/- 0.20
W	1.25 +/- 0.20
T	0.85 +/- 0.15 *1
P	0.30 +/- 0.20
Q	0.40 +/- 0.20
R	Min. 0.01

*1 KNH21C475DA: 1.0+/- 0.15

*1 KNH21C106DA: 1.0+/- 0.15

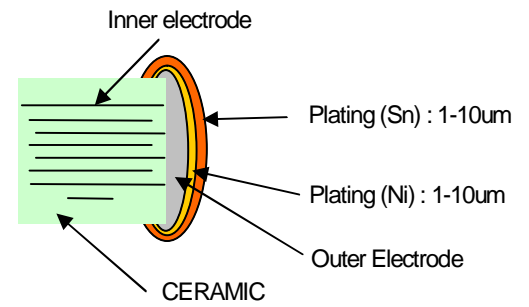
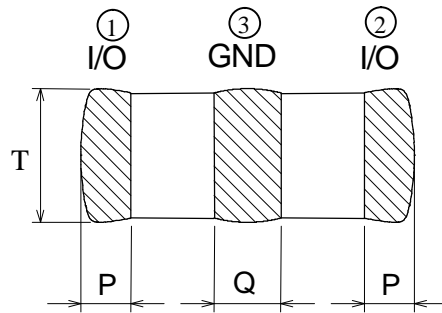

(Figure – 1)

(Figure – 2)

5. Recommended land pattern

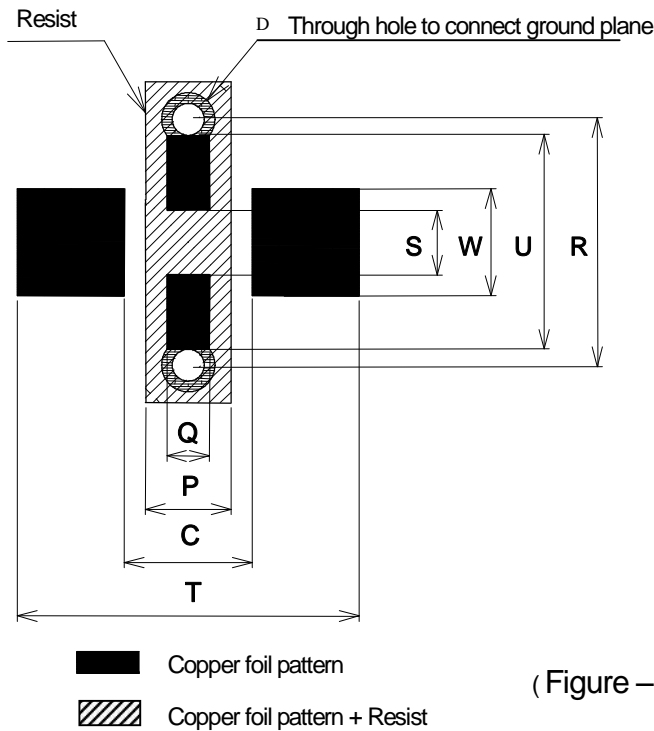

Unit : mm

Symbol	Dimensions
T	3.20
W	1.00
R	2.30
C	1.20
P	0.80
Q	0.40
S	0.60
U	2.00
D	0.3 to 0.4

(Figure – 3)

6. Requirement and measurement method

No	Contents	Requirement	Measurement method and conditions								
1	Appearance	No serious defect.	Microscope (10 magnifications).								
2	Dimensions	Figure – 1	Digital caliper and measurement microscope.								
3	Capacitance	3 – 2 item	Measured by HP4278A. <table border="1" data-bbox="906 622 1414 851"> <thead> <tr> <th>Capacitance</th> <th>Measured frequency</th> <th>Measured voltage</th> </tr> </thead> <tbody> <tr> <td>22pF to 470pF</td> <td>1MHz +- 10kHz</td> <td rowspan="2">1V+- 0.2V rms</td> </tr> <tr> <td>47nF to 10uF</td> <td>1kHz +-10Hz</td> </tr> </tbody> </table>	Capacitance	Measured frequency	Measured voltage	22pF to 470pF	1MHz +- 10kHz	1V+- 0.2V rms	47nF to 10uF	1kHz +-10Hz
Capacitance	Measured frequency	Measured voltage									
22pF to 470pF	1MHz +- 10kHz	1V+- 0.2V rms									
47nF to 10uF	1kHz +-10Hz										
4	Insulation resistance	3 – 1 item	Measured by super meg ohmmeter model SM – 9E (made by TOA). 1-3 or 2-3 (at figure – 1) measured. To measure after charging with the rated voltage for 1 minute at room temperature and normal humidity.								
5	Dielectric strength	No problem observed.	To charge between 1 (or 3) and 2 (at figure – 1) with the 2.5 times high of the rated voltage for 1 to 5 seconds.								
6	Current resistance	No problem observed.	Print rated current for 1 to 5 seconds between 1-2 (at figure – 1).								
7	Solderability	Coverage Min. 90 % Each termination.	Completely coat parts with flux and propanol solution and preheat for 1 minute at 120 to 150deg.. Afterwards, dip parts into solder bath for 2+-0.5 seconds at 230+-5deg.. Solder level checked by naked eye under microscope.								

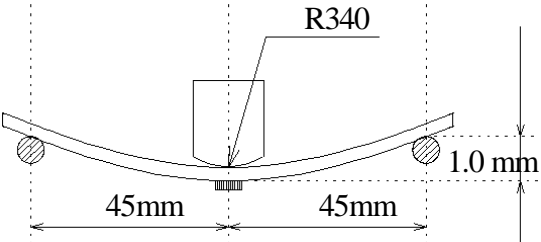
No	Contents	Requirement	Measurement method and conditions															
8	Soldering heat resistance	No mechanical defect. I.R. ; Min. 500M ohms Capacitance variation ; + 20%	Completely coat parts with flux and propanol solution and preheat for 1 minute at 120 to 150deg.. Afterwards, dip parts into solder bath for 10+-1 seconds at 260+-5deg.. Measure after 24+-2 hours.															
9	Bending strength test	No mechanical defect.	As shown below glass epoxy board (t=1.6mm) is soldered. Mechanical pressure is applied and bent 1 mm for 3 seconds.  (Figure - 4)															
10	Temperature cycle	No mechanical defect. I.R. ; Min. 500M ohms Capacitance variation ; + 30%	As specified below, the steps are repeated 10 cycles. <table border="1" data-bbox="906 1176 1412 1406"> <thead> <tr> <th></th> <th>Temperature (deg.)</th> <th>Time (Minutes)</th> </tr> </thead> <tbody> <tr> <td>1</td> <td>-25+-3</td> <td>30+-3</td> </tr> <tr> <td>2</td> <td>Room Temp.</td> <td>2 to 5</td> </tr> <tr> <td>3</td> <td>85+-2</td> <td>30+-3</td> </tr> <tr> <td>4</td> <td>Room Temp.</td> <td>2 to 5</td> </tr> </tbody> </table> Measure after 24+-2 hours.		Temperature (deg.)	Time (Minutes)	1	-25+-3	30+-3	2	Room Temp.	2 to 5	3	85+-2	30+-3	4	Room Temp.	2 to 5
	Temperature (deg.)	Time (Minutes)																
1	-25+-3	30+-3																
2	Room Temp.	2 to 5																
3	85+-2	30+-3																
4	Room Temp.	2 to 5																
11	Humidity test	No mechanical defect. I.R. ; Min. 500M ohm Capacitance variation ; + 30%	Leave at 40+-2deg., humidity 90 to 95%Rh atmosphere for 500+-12 hours. Measure after 24+-2 hours.															
12	High temperature with loading	No mechanical defect. I.R. ; Min. 500Mohm Capacitance variation ; + 30%	Loading rated direct – current voltage continuously under 85+-3 deg. environment for 500+-12 hours. Measure after 24+-2 hours.															

7. Outgoing quality standards

Randomly inspected by ANSi – ASQC Z 1.4

Contents	Standard	AQL(%)
Size-dimension	S-1	2.5
Appearance	I	1
Capacitance	S-4	1
Direct-current resistance	S-4	1
Insulation resistance	S-4	1

8. Recommended storage conditions

Temperature ; -10 to 45 deg.
Humidity ; 45 to 75 %RH

9. Product site

KYOCERA Corporation Kagoshima Kokubu plant Japan

10. Standard soldering conditions

[Reflow soldering condition]

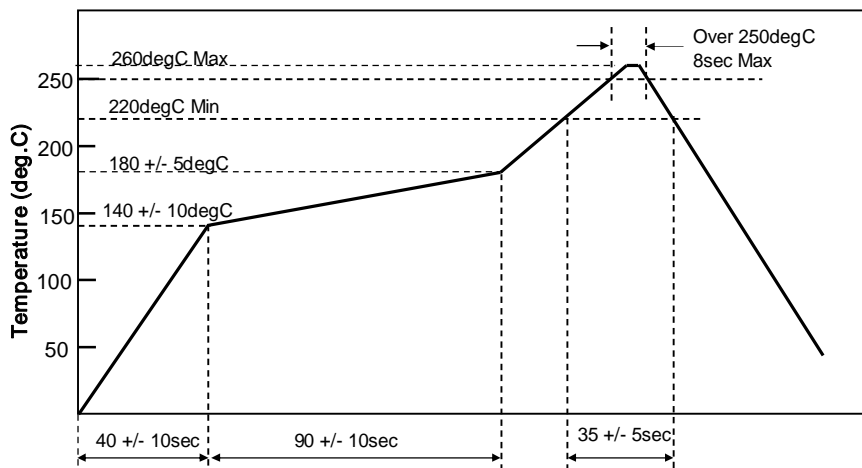

*Pre-heating : 150 degree, 1minute Min.

*Set a temperature difference between Pre-heating and Peak to less than 130 degree

(Figure – 5)

Taping specification

1) Apply

This specification applies to Kyocera chip EMI filter [KNH21 series] taping.

2) Tape

2-1 Material Plastic

2-2 Dimensions

(mm)

Symbol	A	B	C	D	E
Dimensions	1.45±0.2	2.25±0.2	8.0±0.3	3.5±0.05	1.75±0.1
F	G	H	J	t	K
4.0±0.1	2.0±0.05	4.0±0.1	1.5 ^{+0.1} ₋₀	0.25±0.05	1.15 ^{+0.07} _{-0.05}

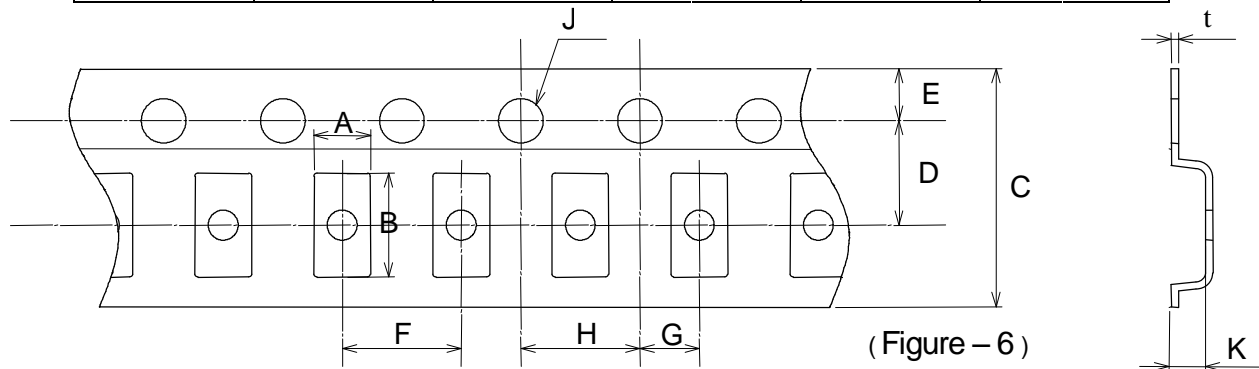

3) Taping configuration

3-1 Unit by reel

Taping for 1 reel is 3,000 pcs STD. Also, components should be placed in consecutively without any vacancy.

3-2 Reel dimensions

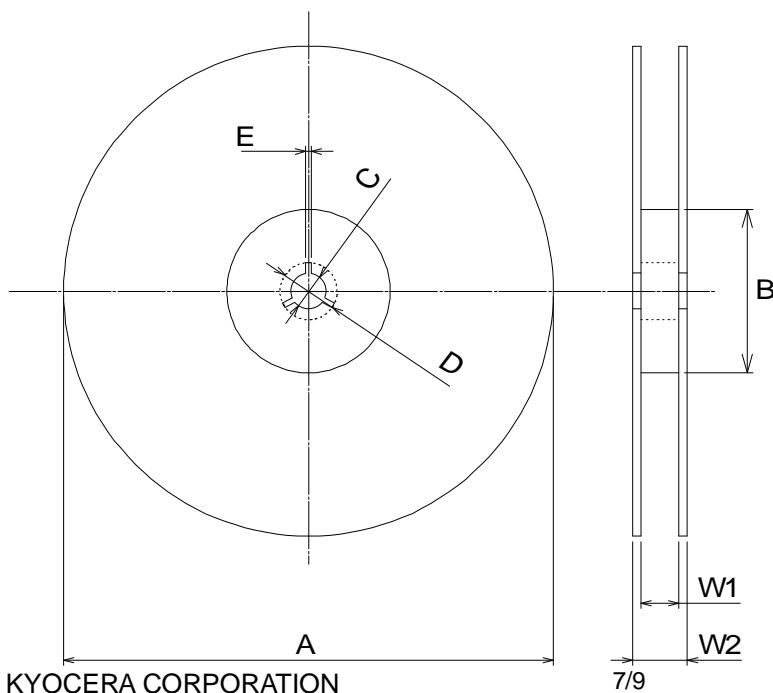

Symbol	Dimensions
A	d180 ⁺⁰ _{-3.0}
B	D60 ^{+1.0} ₋₀
C	d13 ± 0.5
D	d21 ± 0.8
E	2.0 ± 0.5
W1	9.3 ⁺⁰ _{-0.15}
W2	11.4 ± 1.0

No.EE21-KHDC000-02

3 – 3 Leader portion and blank portion

(Figure - 9)

As shown in drawing 8, there is space for leader portion and blank portion. Furthermore, the pulling strength of carrier tape and top tape is 45 + 35 g as shown in drawing 9.

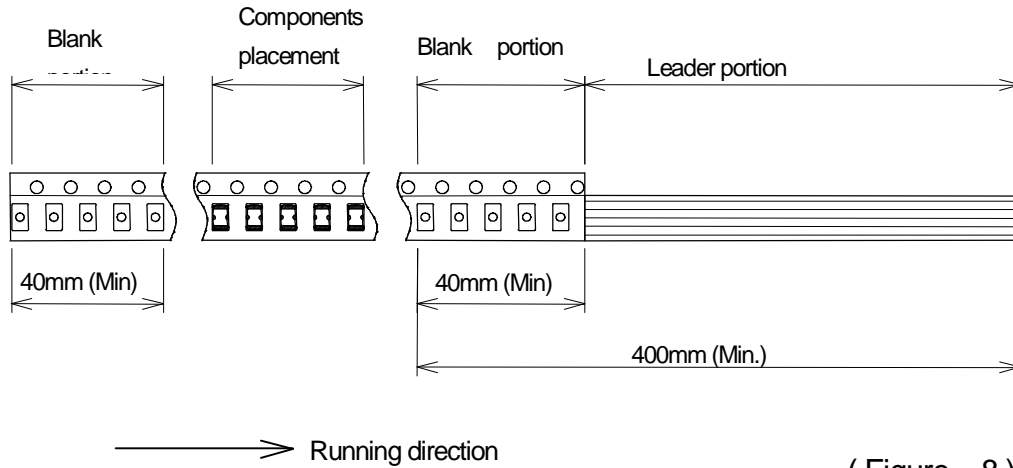

(Figure – 8)

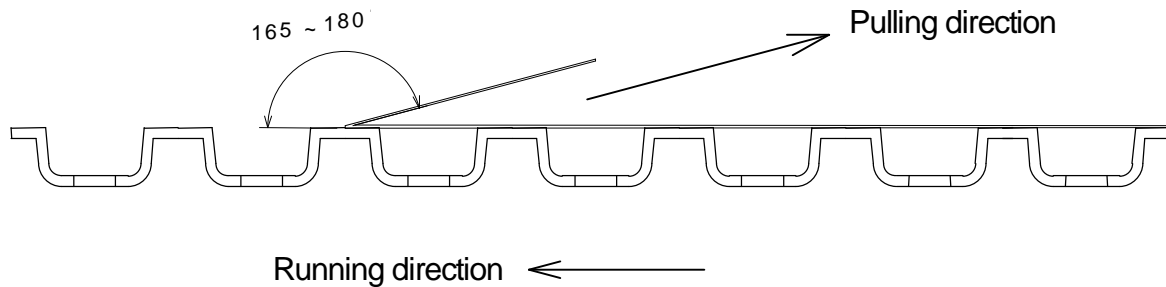

(Figure – 9)

3 – 4 Reel marking

The following contents are marked on one side of reel.

- a) Part number b) Lot number c) Quantity d) Customer name

3 – 5 Other case marking

Adequate packaging is done to avoid damages during delivery.

The other cases have the following marking.

- a) Part number b) Lot number c) Quantity d) Shipment date
- e) Customer name

Limitation of use

Make sure to contact us in advance before considering using this product for the following applications which would require particularly high reliability due to possibility of direct harm to lives and/or properties.

- (1) Use in aerospace or space
- (2) Use in seabed or underground
- (3) Use in control of power station – firepower, waterpower, nuclearpower, etc
- (4) Use in medical treatments including instruments related to lifesaver
- (5) Use in transportation – cars, trains, ships, etc.
- (6) Use in traffic controls
- (7) Use in protection/prevention against disasters or crimes
- (8) Use in information processing
- (9) Others – Use in the equivalent applications mentioned above

This product is designed and manufactured with intention to be used in general electronic equipments for standard applications but with no intention to be used in the following environments which may affect performance of this product. Therefore, make sure to have enough confirmation on performance and reliability of this product in the following environments in advance before use.

- (1) Use in liquids such as water, oil, medical liquid, organic solvent, etc
- (2) Use in direct sunshine, rain, wind, or dust/dirt
- (3) Use in sea wind or place with corrosive gas such as Cl₂, H₂S, NH₃, SO₂, NO₂, etc
- (4) Use in environment with strong static electricity or electromagnetic wave
- (5) Use in located nearby to heat generating part or flammable materials such as vinyl wires
- (6) Use in condensation
- (7) Use in sealed or coated by materials such as resin, etc

Looking for pricing, stock, or lifecycle information?

Click below to explore more details on WIN SOURCE:

-  [View KNH21C105DA3TS on WIN SOURCE](#)
-  [AVX Corp/Kyocera Corp Information](#)

Optimize Your Supply Chain with WIN SOURCE Solutions

-  Global Sourcing Solution
-  Obsolete Management
-  Cost Control Management
-  Shortage Management
-  Alternative Solution
-  Excess Inventory Management