

# BQ25622E I<sup>2</sup>C Controlled 1-Cell, 3A, Maximum 18V Input, Buck Battery Charger with NVDC Power Path Management

## 1 Features

- High-efficiency, 1.5MHz, synchronous switching mode buck charger for single cell battery
  - >90% efficiency down to 25mA output current from 5V input
  - Charge termination from 10mA to 620mA, 10mA steps
  - Flexible JEITA profile for safe charging over temperature
- BATFET control to support shutdown, ship mode and full system reset
  - 1.5µA quiescent current in battery only mode
  - 0.15µA battery leakage current in ship mode
  - 0.1µA battery leakage current in shutdown
- Supports a wide range of input sources
  - wide input operating voltage range with 26V absolute maximum input voltage
  - Maximizes source power with input voltage regulation (VINDPM) and input current regulation (IINDPM)
  - VINDPM threshold automatically tracks battery voltage
- Efficient battery operation with 15mΩ BATFET
- Narrow VDC (NVDC) power path management
  - System instant-on with depleted or no battery
  - Battery supplement when adapter is fully loaded
- Flexible autonomous or I<sup>2</sup>C-controlled modes
- Integrated 12-bit ADC for voltage, current, temperature monitoring
- High accuracy
  - ±0.5% charge voltage regulation
  - ±5% charge current regulation
  - ±5% input current regulation
- Safety
  - Thermal regulation and thermal shutdown
  - Input, system, battery overvoltage protection
  - Battery, converter overcurrent protection
  - Charging safety timer
- Safety Related Certifications
  - IEC 62368-1 CB Certification

## 2 Applications

- [Tablet](#)
- [Gaming and Computer Accessories](#)
- [IP Camera, EPOS](#)
- [Portable Medical Equipment](#)

## 3 Description

The BQ25622E is a highly-integrated 3A switch-mode battery charge management and system power path management device for single cell Li-Ion and Li-polymer batteries. The solution is highly integrated with built-in current sensing, loop compensation, input reverse-blocking FET (RBFET, Q1), high-side switching FET (HSFET, Q2), low-side switching FET (LSFET, Q3), and battery FET (BATFET, Q4) between system and battery. The device uses narrow VDC power path management, regulating the system slightly above the battery voltage without dropping below a configurable minimum system voltage. The low impedance power path optimizes switch-mode operation efficiency, reduces battery charging time, extends battery life during discharging phase, and the ultra-low 0.15µA ship mode current extends battery shelf life. The I<sup>2</sup>C serial interface with charging and system settings makes the BQ25622E a truly flexible solution.

### Device Information

PART NUMBER	PACKAGE <sup>(1)</sup>	BODY SIZE (NOM)
BQ25622E	RYK (WQFN 18)	2.50mm × 3.00mm

(1) For all available packages, see [Section 14](#).

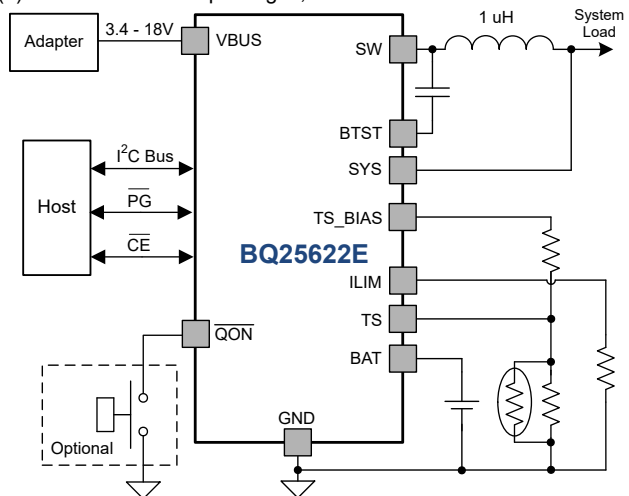

**BQ25622E Simplified Application Diagram**



## Table of Contents

<b>1 Features</b> .....	1	8.6 Register Maps.....	35
<b>2 Applications</b> .....	1	<b>9 Application and Implementation</b> .....	60
<b>3 Description</b> .....	1	9.1 Application Information.....	60
<b>4 Description (continued)</b> .....	3	9.2 Typical Application.....	60
<b>5 Device Comparison</b> .....	4	<b>10 Power Supply Recommendations</b> .....	64
<b>6 Pin Configuration and Functions</b> .....	5	<b>11 Layout</b> .....	65
<b>7 Specifications</b> .....	7	11.1 Layout Guidelines.....	65
7.1 Absolute Maximum Ratings.....	7	11.2 Layout Example.....	65
7.2 ESD Ratings.....	7	<b>12 Device and Documentation Support</b> .....	68
7.3 Recommended Operating Conditions.....	7	12.1 Device Support.....	68
7.4 Thermal Information.....	8	12.2 Documentation Support.....	68
7.5 Electrical Characteristics.....	8	12.3 Receiving Notification of Documentation Updates..	68
7.6 Timing Requirements.....	14	12.4 Support Resources.....	68
7.7 Typical Characteristics.....	16	12.5 Trademarks.....	68
<b>8 Detailed Description</b> .....	17	12.6 Electrostatic Discharge Caution.....	68
8.1 Overview.....	17	12.7 Glossary.....	68
8.2 Functional Block Diagram.....	18	<b>13 Revision History</b> .....	68
8.3 Feature Description.....	19	<b>14 Mechanical, Packaging, and Orderable Information</b> .....	70
8.4 Device Functional Modes.....	30		
8.5 Programming.....	32		

## 4 Description (continued)

The BQ25622E has an ILIM pin to set the default input current limit and a TS\_BIAS pin for controlled thermistor bias.

The power path management regulates the system slightly above battery voltage but does not drop below the programmable minimum system voltage. With this feature, the system maintains operation even when the battery is completely depleted or removed. When the input current limit or input voltage limit is reached, the power path management automatically reduces the charge current. As the system load continues to increase, the battery starts to discharge until the system power requirement is met. This supplement mode prevents overloading the input source.

The BQ25622E initiates and completes a charging cycle without host control. By sensing the battery voltage, it charges the battery in four different phases: trickle charge, pre-charge, constant current (CC) charge, and constant voltage (CV) charge. At the end of the charging cycle, the charger automatically terminates when the charge current is below a preset threshold and the battery voltage is higher than the recharge threshold. Termination is supported for all TS pin temperature zones.

The BQ25622E provides various safety features for battery charging and system operations, including battery negative temperature coefficient thermistor monitoring, charging safety timer, and overvoltage and overcurrent protections. The thermal regulation reduces charge current when the junction temperature exceeds the programmable threshold. The STAT output reports the charging status and any fault conditions. Other safety features include battery temperature sensing for charge mode, thermal shutdown and input UVLO and overvoltage protection. The  $\overline{\text{INT}}$  output notifies the host when a fault occurs or status changes.

The BQ25622E is available in a 18-pin, 2.5mm × 3.0mm WQFN package.

## 5 Device Comparison

**Table 5-1. Device Comparison**

FUNCTION	BQ25620	BQ25622	BQ25622E
Input Voltage Range	3.9V - 18V	3.9V - 18V	3.9V - 18V
Part Configuration	I2C	I2C	I2C
Programmable Charge Voltage	3.5 - 4.8V (10mV per step)	3.5 - 4.8V (10mV per step)	3.5 - 4.8V (10mV per step)
D+/D- USB Detection	Yes	No	No
ILIM Pin	No	Yes	Yes
TS Profile	JEITA	JEITA	JEITA
Quiescent Battery Current	1.5 $\mu$ A	1.5 $\mu$ A	1.5 $\mu$ A
OTG	Yes	Yes	No
OTG Current Limit	2.4A	2.4A	-
ADC	12-bit ADC	12-bit ADC	12-bit ADC
Package	2.5x3mm <sup>2</sup> QFN (18)	2.5x3mm <sup>2</sup> QFN (18)	2.5x3mm <sup>2</sup> QFN (18)

## 6 Pin Configuration and Functions

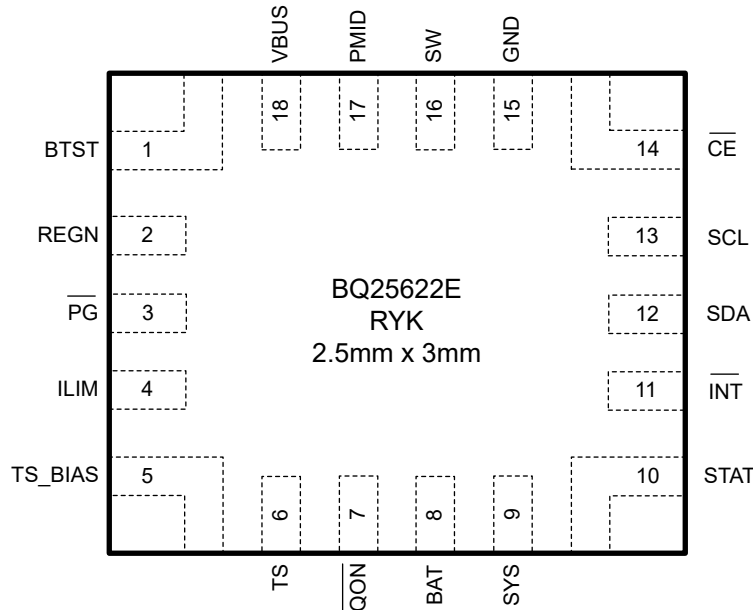

Figure 6-1. BQ25622E Pinout, 18-Pin WQFN Top View

Table 6-1. Pin Functions

NAME	NO.	TYPE <sup>(1)</sup>	DESCRIPTION
BTST	1	P	<b>High Side Switching MOSFET Gate Driver Power Supply</b> – Connect a 10 V or higher rating, 47-nF ceramic capacitor between SW and BTST as the bootstrap capacitor for driving high side switching MOSFET (Q2).
REGN	2	P	<b>The Charger Internal Linear Regulator Output</b> – Internally, REGN is connected to the anode of the boost-strap diode. Connect a 10 V or higher rating, 4.7- $\mu$ F ceramic capacitor from REGN to power ground. The capacitor should be placed close to the IC. The REGN LDO output is used for the internal MOSFETs gate driving voltage.
$\overline{\text{PG}}$	3	DO	<b>Open Drain Active Low Power Good Indicator</b> – Connect to the pull up rail via 10-k $\Omega$ resistor. LOW indicates an input source of $V_{\text{VBUS\_UVLO}} < \text{VBUS} < V_{\text{VBUS\_OVP}}$ . Failing poor source detection or triggering the sleep comparator ( $\text{VBUS} < \text{VBAT} + V_{\text{SLEEP}}$ ) also causes $\overline{\text{PG}}$ to transition HIGH.
ILIM	4	AIO	<b>Input Current Limit Setting Input Pin</b> – ILIM pin sets the input current limit as $I_{\text{INREG}} = K_{\text{ILIM}} / R_{\text{ILIM}}$ , where $R_{\text{ILIM}}$ is connected from ILIM pin to GND. The input current is limited to the lower of the two values set by ILIM pin and IINDPM register bits. The ILIM pin can also be used to monitor input current. The input current is proportional to the voltage on ILIM pin and can be calculated by $I_{\text{IN}} = (K_{\text{ILIM}} \times V_{\text{ILIM}}) / (R_{\text{ILIM}} \times 0.8)$ . The ILIM pin function is disabled when EN_EXTILIM bit is set to 0.
TS_BIAS	5	P	<b>Bias for the TS Resistor Voltage Divider</b> – Provides the bias voltage for the TS resistor voltage divider.
TS	6	AI	<b>Temperature Qualification Voltage Input</b> – Connect a negative temperature coefficient thermistor. Program temperature window with a resistor divider from TS pin bias reference to TS, then to GND. Charge suspends when TS pin voltage is out of range. Recommend a 103AT-2 10-k $\Omega$ thermistor.
$\overline{\text{QON}}$	7	DI	<b>BATFET Enable or System Power Reset Control Input</b> – If the charger is in ship mode, a logic low on this pin with $t_{\text{SM\_EXIT}}$ duration forces the device to exit ship mode. If the charger is not in ship mode, a logic low on this pin with $t_{\text{QON\_RST}}$ initiates a full system power reset if either $V_{\text{VBUS}} < V_{\text{VBUS\_UVLO}}$ or $\text{BATFET\_CTRL\_WVBUS} = 1$ . $\overline{\text{QON}}$ has no effect during shutdown mode. The pin contains an internal pull-up to maintain default high logic.
BAT	8	P	<b>The Battery Charging Power Connection</b> – Connect to the positive terminal of the battery pack. The internal BATFET is connected between SYS and BAT.
SYS	9	P	<b>The Charger Output Voltage to System</b> –The Buck converter output connection point to the system. The internal BATFET is connected between SYS and BAT.
STAT	10	DO	<b>Open Drain Charge Status Output</b> – It indicates various charger operations. Connect to the pull up rail via 10-k $\Omega$ resistor. LOW indicates charging in progress. HIGH indicates charging completed or charging disabled. When any fault condition occurs, STAT pin blinks at 1Hz. Setting DIS_STAT = 1 disables the STAT pin function, causing the pin to be pulled HIGH. Leave floating if unused.

**Table 6-1. Pin Functions (continued)**

NAME	NO.	TYPE <sup>(1)</sup>	DESCRIPTION
INT	11	DO	<b>Open Drain Interrupt Output.</b> – Connect to the pull up rail via 10-kΩ resistor. The INT pin sends an active low, 256-μs pulse to the host to report the charger device status and faults.
SDA	12	DIO	<b>I<sup>2</sup>C Interface Data</b> – Connect SDA to the logic rail through a 10-kΩ resistor.
SCL	13	DI	<b>I<sup>2</sup>C Interface Clock</b> – Connect SCL to the logic rail through a 10-kΩ resistor.
CE	14	DI	<b>Active Low Charge Enable Pin</b> – Battery charging is enabled when EN_CHG bit is 1 and CE pin is LOW. CE pin must be pulled HIGH or LOW, do not leave floating.
GND	15	P	<b>Ground Return</b>
SW	16	P	<b>Switching Node Connecting to Output Inductor</b> – Internally SW is connected to the source of the n-channel HSFET and the drain of the n-channel LSFET. Connect the 47-nF bootstrap capacitor from SW to BTST.
PMID	17	P	<b>HSFET Drain Connection</b> – Internally PMID is connected to the drain of the reverse blocking MOSFET (RBFET) and the drain of HSFET.
VBUS	18	P	<b>Charger Input Voltage</b> – The internal n-channel reverse block MOSFET (RBFET) is connected between VBUS and PMID with VBUS on source.

(1) AI = Analog input, AO = Analog Output, AIO = Analog input Output, DI = Digital input, DO = Digital Output, DIO = Digital input Output, P = Power

## 7 Specifications

### 7.1 Absolute Maximum Ratings

over operating free-air temperature range (unless otherwise noted)<sup>(1)</sup>

		MIN	MAX	UNIT
Voltage range (with respect to GND)	VBUS (converter not switching)	-2	26	V
	PMID (converter not switching)	-0.3	26	V
	BAT, SYS (converter not switching)	-0.3	6	V
	SW	-2 (50ns)	21	V
	BTST (when converter switching)	-0.3	27	V
	$\overline{CE}$ , STAT, SCL, SDA, $\overline{INT}$ , REGN, $\overline{QON}$	-0.3	6	V
	ILIM, $\overline{PG}$ , TS, TS_BIAS	-0.3	6	V
Output Sink Current	$\overline{INT}$ , STAT, $\overline{PG}$		6	mA
Differential Voltage	BTST-SW	-0.3	6	V
	PMID-VBUS	-0.3	6	V
	SYS-BAT	-0.3	6	V
T <sub>J</sub>	Junction temperature	-40	150	°C
T <sub>stg</sub>	Storage temperature	-55	150	°C

- (1) Stresses beyond those listed under *Absolute Maximum Rating* may cause permanent damage to the device. These are stress ratings only, which do not imply functional operation of the device at these or any other conditions beyond those indicated under *Recommended Operating Condition*. Exposure to absolute-maximum-rated conditions for extended periods may affect device reliability.

### 7.2 ESD Ratings

			VALUE	UNIT
V <sub>(ESD)</sub>	Electrostatic discharge	Human body model (HBM), per ANSI/ESDA/JEDEC JS-001, all pins <sup>(1)</sup>	±2000	V
		Charged device model (CDM), per JEDEC specification JESD22-C101, all pins <sup>(2)</sup>	±250	

- (1) JEDEC document JEP155 states that 500-V HBM allows safe manufacturing with a standard ESD control process.  
(2) JEDEC document JEP157 states that 250-V CDM allows safe manufacturing with a standard ESD control process.

### 7.3 Recommended Operating Conditions

over operating free-air temperature range (unless otherwise noted)

		MIN	NOM	MAX	UNIT
V <sub>VBUS</sub>	Input voltage	3.9		18	V
V <sub>BAT</sub>	Battery voltage			4.8	V
I <sub>VBUS</sub>	Input current			3.2	A
I <sub>SW</sub>	Output current (SW)			3.5	A
I <sub>BAT</sub>	Fast charging current			3	A
	RMS discharge current (continuously)			6	A
	Peak discharge current (up to 50ms)			10	A
I <sub>REGN</sub>	Maximum REGN Current			20	mA
T <sub>A</sub>	Ambient temperature	-40		85	°C
T <sub>J</sub>	Junction temperature	-40		125	°C
L <sub>SW</sub>	Inductor for the switching regulator	0.68		2.2	μH
C <sub>VBUS</sub>	VBUS capacitor (without de-rating)	1			μF
C <sub>PMID</sub>	PMID capacitor (without de-rating)	10			μF
C <sub>SYS</sub>	SYS capacitor (without de-rating)	20		500	μF

### 7.3 Recommended Operating Conditions (continued)

over operating free-air temperature range (unless otherwise noted)

		MIN	NOM	MAX	UNIT
C <sub>BAT</sub>	BAT capacitor (without de-rating)	10			μF

### 7.4 Thermal Information

THERMAL METRIC <sup>(1)</sup>		BQ25622E		UNIT
		RYK (QFN)		
		18 pins		
R <sub>θJA</sub>	Junction-to-ambient thermal resistance	60.1		°C/W
R <sub>θJC(top)</sub>	Junction-to-case (top) thermal resistance	42.1		°C/W
R <sub>θJB</sub>	Junction-to-board thermal resistance	13.0		°C/W
Ψ <sub>JT</sub>	Junction-to-top characterization parameter	1.3		°C/W
Ψ <sub>JB</sub>	Junction-to-board characterization parameter	12.8		°C/W

(1) For more information about traditional and new thermal metrics, see the [Semiconductor and IC Package Thermal Metrics](#) application report.

### 7.5 Electrical Characteristics

V<sub>VBUS\_UVLOZ</sub> < V<sub>VBUS</sub> < V<sub>VBUS\_OVP</sub>, T<sub>J</sub> = -40°C to +125°C, and T<sub>J</sub> = 25°C for typical values (unless otherwise noted)

PARAMETER		TEST CONDITIONS	MIN	TYP	MAX	UNIT
<b>QUIESCENT CURRENTS</b>						
I <sub>Q_BAT</sub>	Quiescent battery current (BAT, SYS, SW) when the charger is in the battery only mode, BATFET is enabled, ADC is disabled	VBAT = 4V, No VBUS, BATFET is enabled, I2C enabled, ADC disabled, system is powered by battery. -40 °C < T <sub>J</sub> < 60 °C		1.5	3	μA
I <sub>Q_BAT_ADC</sub>	Quiescent battery current (BAT, SYS, SW) when the charger is in the battery only mode, BATFET is enabled, ADC is enabled	VBAT = 4V, No VBUS, BATFET is enabled, I2C enabled, ADC enabled, system is powered by battery. -40 °C < T <sub>J</sub> < 60 °C		260		μA
I <sub>Q_BAT_SD</sub>	Quiescent battery current (BAT) when the charger is in shutdown mode, BATFET is disabled, ADC is disabled	VBAT = 4V, No VBUS, BATFET is disabled, I2C disabled, in shutdown mode, ADC disabled, T <sub>J</sub> < 60 °C		0.1	0.2	μA
I <sub>Q_BAT_SHIP</sub>	Quiescent battery current (BAT) when the charger is in ship mode, BATFET is disabled, ADC is disabled	VBAT = 4V, No VBUS, BATFET is disabled, I2C disabled, in ship mode, ADC disabled, T <sub>J</sub> < 60 °C		0.15	0.5	μA
I <sub>Q_VBUS</sub>	Quiescent input current (VBUS)	VBUS = 5V, VBAT = 4V, charge disabled, converter switching, ISYS = 0A, PFM enabled		450		μA
I <sub>Q_VBUS_HIZ</sub>	Quiescent input current (VBUS) in HIZ	VBUS = 5V, VBAT = 4V, HIZ mode, ADC disabled		5	20	μA
		VBUS = 15V, VBAT = 4V, HIZ mode, ADC disabled		20	35	μA
<b>VBUS / VBAT SUPPLY</b>						
V <sub>VBUS_OP</sub>	VBUS operating range		3.9		18	V
V <sub>VBUS_UVLO</sub>	VBUS falling to turn off I2C, no battery	VBUS falling	3.0	3.15	3.3	V
V <sub>VBUS_UVLOZ</sub>	VBUS rising for active I2C, no battery	VBUS rising	3.2	3.35	3.5	V
V <sub>VBUS_OVP</sub>	VBUS overvoltage rising threshold	VBUS rising, VBUS_OVP = 0	6.1	6.4	6.7	V
V <sub>VBUS_OVPZ</sub>	VBUS overvoltage falling hreshold	VBUS rising, VBUS_OVP = 0	5.8	6.0	6.2	V

## 7.5 Electrical Characteristics (continued)

$V_{VBUS\_UVLOZ} < V_{VBUS} < V_{VBUS\_OVP}$ ,  $T_J = -40^{\circ}\text{C}$  to  $+125^{\circ}\text{C}$ , and  $T_J = 25^{\circ}\text{C}$  for typical values (unless otherwise noted)

PARAMETER		TEST CONDITIONS	MIN	TYP	MAX	UNIT
$V_{VBUS\_OVP}$	VBUS overvoltage rising threshold	VBUS rising, $V_{VBUS\_OVP} = 1$	18.2	18.5	18.8	V
$V_{VBUS\_OVPZ}$	VBUS overvoltage falling threshold	VBUS falling, $V_{VBUS\_OVP} = 1$	17.4	17.7	18.0	V
$V_{SLEEP}$	Enter Sleep mode threshold	(VBUS - VBAT), VBUS falling	9	45	85	mV
$V_{SLEEPZ}$	Exit Sleep mode threshold	(VBUS - VBAT), VBUS rising	115	220	340	mV
$V_{BAT\_UVLOZ}$	BAT voltage for active I2C, turn on BATFET, no VBUS	VBAT rising	2.3	2.4	2.5	V
$V_{BAT\_UVLO}$	BAT voltage to turnoff I2C, turn off BATFET, no VBUS	VBAT falling, $V_{BAT\_UVLO} = 0$	2.1	2.2	2.3	V
		VBAT falling, $V_{BAT\_UVLO} = 1$	1.7	1.8	1.9	V
$V_{POORSRC}$	Bad adapter detection threshold	VBUS falling	3.6	3.7	3.75	V
$I_{POORSRC}$	Bad adapter detection current source			10		mA
<b>POWER-PATH MANAGEMENT</b>						
$V_{SYS\_REG\_ACC}$	Typical system voltage regulation	ISYS = 0A, VBAT > VSYSMIN, Charge Disabled. Offset above VBAT		50		mV
		ISYS = 0A, $V_{BAT} < VSYSMIN$ , Charge Disabled. Offset above VSYSMIN		230		mV
$V_{SYSMIN\_RNG}$	VSYSMIN register range		2.56		3.84	V
$V_{SYSMIN\_REG\_STEP}$	VSYSMIN register step size			80		mV
$V_{SYSMIN\_REG\_ACC}$	Minimum DC system voltage output	ISYS = 0A, $V_{BAT} < VSYSMIN = B00h$ (3.52V), Charge Disabled	3.52	3.75		V
$V_{SYS\_SHORT}$	VSYS short voltage falling threshold to enter forced PFM			0.9		V
$V_{SYS\_SHORTZ}$	VSYS short voltage rising threshold to exit forced PFM			1.1		V
<b>BATTERY CHARGER</b>						
$V_{REG\_RANGE}$	Typical charge voltage regulation range		3.50		4.80	V
$V_{REG\_STEP}$	Typical charge voltage step			10		mV
$V_{REG\_ACC}$	Charge voltage accuracy	$T_J = 25^{\circ}\text{C}$	-0.3		0.3	%
		$T_J = -10^{\circ}\text{C} - 85^{\circ}\text{C}$	-0.4		0.4	%
$I_{CHG\_RANGE}$	Typical charge current regulation range		0.08		3.04	A
$I_{CHG\_STEP}$	Typical charge current regulation step			80		mA
$I_{CHG\_ACC}$	Charge current accuracy	VBAT = 3.1V or 3.8V, ICHG = 1760mA, $T_J = -10^{\circ}\text{C} - 85^{\circ}\text{C}$	-5		5	%
		VBAT = 3.1V or 3.8V, ICHG = 1040mA, $T_J = -10^{\circ}\text{C} - 85^{\circ}\text{C}$	-5.5		5.5	%
		VBAT = 3.1V or 3.8V, ICHG = 320mA, $T_J = -10^{\circ}\text{C} - 85^{\circ}\text{C}$	-5.5		5.5	%
$I_{PRECHG\_RANGE}$	Typical pre-charge current range		20		620	mA
$I_{PRECHG\_STEP}$	Typical pre-charge current step			20		mA
$I_{PRECHG\_ACC}$	Pre-charge current accuracy when $V_{BAT}$ below $V_{SYSMIN}$ setting	VBAT = 2.5V, $I_{PRECHG} = 500\text{mA}$ , $T_J = -10^{\circ}\text{C} - 85^{\circ}\text{C}$	-12		12	%
		VBAT = 2.5V, $I_{PRECHG} = 200\text{mA}$ , $T_J = -10^{\circ}\text{C} - 85^{\circ}\text{C}$	-12		12	%
		VBAT = 2.5V, $I_{PRECHG} = 100\text{mA}$ , $T_J = -10^{\circ}\text{C} - 85^{\circ}\text{C}$	-15		15	%

## 7.5 Electrical Characteristics (continued)

$V_{VBUS\_UVLOZ} < V_{VBUS} < V_{VBUS\_OVP}$ ,  $T_J = -40^{\circ}\text{C}$  to  $+125^{\circ}\text{C}$ , and  $T_J = 25^{\circ}\text{C}$  for typical values (unless otherwise noted)

PARAMETER		TEST CONDITIONS	MIN	TYP	MAX	UNIT
$I_{TERM\_RANGE}$	Typical termination current range		10		620	mA
$I_{TERM\_STEP}$	Typical termination current step			10		mA
$I_{TERM\_ACC}$	Termination current accuracy	$I_{TERM} = 20\text{mA}$ , $T_J = -10^{\circ}\text{C} - 85^{\circ}\text{C}$	-60		60	%
		$I_{TERM} = 100\text{mA}$ , $T_J = -10^{\circ}\text{C} - 85^{\circ}\text{C}$	-15		15	%
		$I_{TERM} = 300\text{mA}$ , $T_J = -10^{\circ}\text{C} - 85^{\circ}\text{C}$	-13		13	%
$V_{BAT\_SHORTZ}$	Battery short voltage rising threshold to start pre-charge	VBAT rising		2.25		V
$V_{BAT\_SHORT}$	Battery short voltage falling threshold to stop pre-charge	VBAT falling, $V_{BAT\_UVLO}=0$		2.05		V
$V_{BAT\_SHORT}$	Battery short voltage falling threshold to stop pre-charge	VBAT falling, $V_{BAT\_UVLO}=1$		1.85		V
$I_{BAT\_SHORT}$	Battery short trickle charging current	$VBAT < V_{BAT\_SHORTZ}$ , $I_{TRICKLE} = 0$	15	25	35	mA
		$VBAT < V_{BAT\_SHORTZ}$ , $I_{TRICKLE} = 1$	62	82	102	mA
$V_{BAT\_LOWVZ}$	Battery voltage rising threshold	Transition from pre-charge to fast charge	2.9	3.0	3.1	V
$V_{BAT\_LOWV}$	Battery voltage falling threshold	Transition from fast charge to pre-charge	2.7	2.8	2.9	V
$V_{RECHG}$	Battery recharge threshold below $V_{REG}$	VBAT falling, $V_{RECHG} = 0$		100		mV
		VBAT falling, $V_{RECHG} = 1$		200		mV
$I_{PMID\_LOAD}$	PMID discharge load current		20	30		mA
$I_{BAT\_LOAD}$	Battery discharge load current		20	30		mA
$I_{SYS\_LOAD}$	System discharge load current		20	30		mA
<b>BATFET</b>						
$R_{BATFET}$	MOSFET on resistance from SYS to BAT			15	25	m $\Omega$
<b>BATTERY PROTECTIONS</b>						
$V_{BAT\_OVP}$	Battery overvoltage rising threshold	As percentage of $V_{REG}$	103	104	105	%
$V_{BAT\_OVPZ}$	Battery overvoltage falling threshold	As percentage of $V_{REG}$	101	102	103	%
$I_{BATFET\_OCP}$	BATFET over-current rising threshold		6			A
$I_{BAT\_PK}$	Battery discharging peak current rising threshold	$IBAT\_PK = 10$	6			A
		$IBAT\_PK = 11$	12			A
<b>INPUT VOLTAGE / CURRENT REGULATION</b>						
$V_{INDPM\_RANGE}$	Typical input voltage regulation range		3.8		16.8	V
$V_{INDPM\_STEP}$	Typical input voltage regulation step			40		mV
$V_{INDPM\_ACC}$	Input voltage regulation accuracy	$V_{INDPM}=4.6\text{V}$	-4		4	%
		$V_{INDPM}=8\text{V}$	-3		3	%
		$V_{INDPM}=16\text{V}$	-2		2	%
$V_{INDPM\_BAT\_TRACK}$	Battery tracking $V_{INDPM}$ accuracy	$VBAT = 3.9\text{V}$ , $V_{INDPM\_BAT\_TRACK}=1$ , $V_{INDPM} = 4\text{V}$	4.15	4.3	4.45	V
$I_{INDPM\_RANGE}$	Typical input current regulation range		0.1		3.2	A
$I_{INDPM\_STEP}$	Typical input current regulation step			20		mA

## 7.5 Electrical Characteristics (continued)

$V_{VBUS\_UVLOZ} < V_{VBUS} < V_{VBUS\_OVP}$ ,  $T_J = -40^{\circ}\text{C}$  to  $+125^{\circ}\text{C}$ , and  $T_J = 25^{\circ}\text{C}$  for typical values (unless otherwise noted)

PARAMETER		TEST CONDITIONS	MIN	TYP	MAX	UNIT
I <sub>INDPM\_ACC</sub>	Input current regulation accuracy	IINDPM = 500mA, VBUS=5V	450	475	500	mA
		IINDPM = 900mA, VBUS=5V	810	855	900	mA
		IINDPM = 1500mA, VBUS=5V	1350	1425	1500	mA
K <sub>ILIM</sub>	ILIM Pin Scale Factor, IINREG = K <sub>ILIM</sub> / R <sub>ILIM</sub>	INREG = 1.6 A	2250	2500	2750	AΩ
<b>THERMAL REGULATION AND THERMAL SHUTDOWN</b>						
T <sub>REG</sub>	Junction temperature regulation accuracy	TREG = 1		120		°C
		TREG = 0		60		°C
T <sub>SHUT</sub>	Thermal Shutdown Rising Threshold	Temperature Increasing		140		°C
T <sub>SHUT\_HYS</sub>	Thermal Shutdown Falling Hysteresis	Temperature Decreasing by T <sub>SHUT\_HYS</sub>		30		°C
<b>THERMISTOR COMPARATORS (CHARGE MODE)</b>						
V <sub>TS\_COLD</sub>	TS pin rising voltage threshold for TH1 comparator to transition from TS_COOL to TS_COLD. Charge suspended above this voltage.	As Percentage to TS pin bias reference (-5°C w/ 103AT), TS_TH1_TH2_TH3 = 100, 101, 110	75.0	75.5	76.0	%
		As Percentage to TS pin bias reference (0°C w/ 103AT), TS_TH1_TH2_TH3 = 000, 001, 010, 011, 111	72.8	73.3	73.8	%
V <sub>TS\_COLDZ</sub>	TS pin falling voltage threshold for TH1 comparator to transition from TS_COLD to TS_COOL. TS_COOL charge settings resume below this voltage.	As Percentage to TS pin bias reference (-2.5°C w/ 103AT), TS_TH1_TH2_TH3 = 100, 101, 110	73.9	74.4	74.9	%
		As Percentage to TS pin bias reference (2.5°C w/ 103AT), TS_TH1_TH2_TH3 = 000, 001, 010, 011, 111	71.7	72.2	72.7	%
V <sub>TS\_COOL</sub>	TS pin rising voltage threshold for TH2 comparator to transition from TS_PRECOOL to TS_COOL. TS_COOL charging settings used above this voltage.	As Percentage to TS pin bias reference (5°C w/ 103AT), TS_TH1_TH2_TH3 = 000, 100	70.6	71.1	71.6	%
		As Percentage to TS pin bias reference (10°C w/ 103AT), TS_TH1_TH2_TH3 = 001, 101, 110, 111	67.9	68.4	68.9	%
		As Percentage to TS pin bias reference (15°C w/ 103AT), TS_TH1_TH2_TH3 = 010	65.0	65.5	66.0	%
		As Percentage to TS pin bias reference (20°C w/ 103AT), TS_TH1_TH2_TH3 = 011	61.9	62.4	62.9	%
V <sub>TS\_COOLZ</sub>	TS pin falling voltage threshold for TH2 comparator to transition from TS_COOL to TS_PRECOOL. TS_PRECOOL charging settings resume below this voltage.	As Percentage to TS pin bias reference (7.5°C w/ 103AT), TS_TH1_TH2_TH3 = 000, 100	69.3	69.8	70.3	%
		As Percentage to TS pin bias reference (12.5°C w/ 103AT), TS_TH1_TH2_TH3 = 001, 101, 110, 111	66.6	67.1	67.6	%
		As Percentage to TS pin bias reference (17.5°C w/ 103AT), TS_TH1_TH2_TH3 = 010	63.7	64.2	64.7	%
		As Percentage to TS pin bias reference (22.5°C w/ 103AT), TS_TH1_TH2_TH3 = 011	60.6	61.1	61.6	%

## 7.5 Electrical Characteristics (continued)

$V_{VBUS\_UVLOZ} < V_{VBUS} < V_{VBUS\_OVP}$ ,  $T_J = -40^{\circ}\text{C}$  to  $+125^{\circ}\text{C}$ , and  $T_J = 25^{\circ}\text{C}$  for typical values (unless otherwise noted)

PARAMETER		TEST CONDITIONS	MIN	TYP	MAX	UNIT
$V_{TS\_PRECOOL}$	TS pin rising voltage threshold for TH3 comparator to transition from TS_NORMAL to TS_PRECOOL. TS_PRECOOL charge settings used above this voltage.	As Percentage to TS pin bias reference (15°C w/ 103AT), TS_TH1_TH2_TH3 = 000, 001, 100, 101	65.0	65.5	66.0	%
		As Percentage to TS pin bias reference (20°C w/ 103AT), TS_TH1_TH2_TH3 = 010, 011, 110, 111	61.9	62.4	62.9	%
$V_{TS\_PRECOOLZ}$	TS pin falling voltage threshold for TH3 comparator to transition from TS_PRECOOL to TS_NORMAL. Normal charging resumes below this voltage.	As Percentage to TS pin bias reference (17.5°C w/ 103AT), TS_TH1_TH2_TH3 = 000, 001, 100, 101	63.7	64.2	64.7	%
		As Percentage to TS pin bias reference (22.5°C w/ 103AT), TS_TH1_TH2_TH3 = 010, 011, 110, 111	60.6	61.1	61.6	%
$V_{TS\_PREWARM}$	TS pin falling voltage threshold for TH4 comparator to transition from TS_NORMAL to TS_PREWARM. TS_PREWARM charging settings used below this voltage.	As Percentage to TS pin bias reference (35°C w/ 103AT), TS_TH4_TH5_TH6 = 000, 001, 010, 100, 101	51.5	52.0	52.5	%
		As Percentage to TS pin bias reference (40°C w/ 103AT), TS_TH4_TH5_TH6 = 011, 110, 111	47.9	48.4	48.9	%
$V_{TS\_PREWARMZ}$	TS pin rising voltage threshold for TH4 comparator to transition from TS_PREWARM to TS_NORMAL. Normal charging resumes above this voltage.	As Percentage to TS pin bias reference (32.5°C w/ 103AT), TS_TH4_TH5_TH6 = 000, 001, 010, 100, 101	53.3	53.8	54.3	%
		As Percentage to TS pin bias reference (37.5°C w/ 103AT), TS_TH4_TH5_TH6 = 011, 110, 111	49.2	49.7	50.2	%
$V_{TS\_WARM}$	TS pin falling voltage threshold for TH5 comparator to transition from TS_PREWARM to TS_WARM. TS_WARM charging settings used below this voltage.	As Percentage to TS pin bias reference (40°C w/ 103AT), TS_TH4_TH5_TH6 = 000, 100	47.9	48.4	48.9	%
		As Percentage to TS pin bias reference (45°C w/ 103AT), TS_TH4_TH5_TH6 = 001, 101, 110	44.3	44.8	45.3	%
		As Percentage to TS pin bias reference (50°C w/ 103AT), TS_TH4_TH5_TH6 = 010, 111	40.7	41.2	41.7	%
		As Percentage to TS pin bias reference (55°C w/ 103AT), TS_TH4_TH5_TH6 = 011	37.2	37.7	38.2	%
$V_{TS\_WARMZ}$	TS pin rising voltage threshold for TH5 comparator to transition from TS_WARM to TS_PREWARM. TS_PREWARM charging settings resume above this voltage.	As Percentage to TS pin bias reference (37.5°C w/ 103AT), TS_TH4_TH5_TH6 = 000, 100	49.2	49.7	50.2	%
		As Percentage to TS pin bias reference (42.5°C w/ 103AT), TS_TH4_TH5_TH6 = 001, 101, 110	45.6	46.1	46.6	%
		As Percentage to TS pin bias reference (47.5°C w/ 103AT), TS_TH4_TH5_TH6 = 010, 111	42.0	42.5	43.0	%
		As Percentage to TS pin bias reference (52.5°C w/ 103AT), TS_TH4_TH5_TH6 = 011	38.5	39	39.5	%
$V_{TS\_HOT}$	TS pin falling voltage threshold for TH6 comparator to transition from TS_WARM to TS_HOT. Charging is suspended below this voltage.	As Percentage to TS pin bias reference (50°C w/ 103AT), TS_TH4_TH5_TH6 = 100 or 101	40.7	41.2	41.7	%
		As Percentage to TS pin bias reference (60°C w/ 103AT), TS_TH4_TH5_TH6 = 000, 001, 010, 011, 110 or 111	33.9	34.4	34.9	%

## 7.5 Electrical Characteristics (continued)

 $V_{VBUS\_UVLOZ} < V_{VBUS} < V_{VBUS\_OVP}$ ,  $T_J = -40^{\circ}\text{C}$  to  $+125^{\circ}\text{C}$ , and  $T_J = 25^{\circ}\text{C}$  for typical values (unless otherwise noted)

PARAMETER		TEST CONDITIONS	MIN	TYP	MAX	UNIT
$V_{TS\_HOTZ}$	TS pin rising voltage threshold for TH6 comparator to transition from TS_HOT to TS_WARM. TS_WARM charging settings resume above this voltage.	As Percentage to TS pin bias reference (47.5°C w/ 103AT), TS_TH4_TH5_TH6 = 100 or 101	42.0	42.5	43.0	%
		As Percentage to TS pin bias reference (57.5°C w/ 103AT), TS_TH4_TH5_TH6 = 000, 001, 010, 011, 110 or 111	35.2	35.7	36.2	%
<b>SWITCHING CONVERTER</b>						
$F_{SW}$	PWM switching frequency	Oscillator frequency	1.35	1.5	1.65	MHz
<b>MOSFET TURN-ON RESISTANCE</b>						
$R_{Q1\_ON}$	VBUS to PMID on resistance	$T_J = -40^{\circ}\text{C}-85^{\circ}\text{C}$		26	34	mΩ
$R_{Q2\_ON}$	Buck high-side switching MOSFET turn on resistance between PMID and SW	$T_J = -40^{\circ}\text{C}-85^{\circ}\text{C}$		55	78	mΩ
$R_{Q3\_ON}$	Buck low-side switching MOSFET turn on resistance between SW and PGND	$T_J = -40^{\circ}\text{C}-85^{\circ}\text{C}$		60	90	mΩ
<b>REGN LDO</b>						
$V_{REGN}$	REGN LDO output voltage	$V_{VBUS} = 5\text{V}$ , $I_{REGN} = 20\text{mA}$	4.4	4.6		V
		$V_{VBUS} = 9\text{V}$ , $I_{REGN} = 20\text{mA}$	4.8	5.0	5.2	V
$V_{REGNZ\_OK}$	REGN not good falling threshold	Converter switching		3.2		V
		Converter not switching		2.3		V
$I_{REGN\_LIM}$	REGN LDO current limit	$V_{VBUS} = 5\text{V}$ , $V_{REGN} = 4.3\text{V}$	20			mA
$I_{TS\_BIAS\_FAULT}$	Rising threshold to transition from TSBIAS good condition to fault condition	REGN=5V; ISINK applied on TS_BIAS pin	2.5	4.5	8	mA
$I_{TS\_BIAS\_FAULTZ}$	Falling threshold to transition from TSBIAS fault condition to good condition	REGN=5V; ISINK applied on TS_BIAS pin	2	3.85	7	mA
<b>ADC MEASUREMENT ACCURACY AND PERFORMANCE</b>						
$t_{ADC\_CONV}$	Conversion-time, Each Measurement	ADC_SAMPLE = 00		30		ms
		ADC_SAMPLE = 01		15		ms
		ADC_SAMPLE = 10		7.5		ms
		ADC_SAMPLE = 11		3.75		ms
$ADC_{RES}$	Effective Resolution	ADC_SAMPLE = 00	11	12		bits
		ADC_SAMPLE = 01	10	11		bits
		ADC_SAMPLE = 10	9	10		bits
		ADC_SAMPLE = 11	8	9		bits
<b>ADC MEASUREMENT RANGE AND LSB</b>						
$IBUS\_ADC$	ADC Bus Current Reading	Range	-4		4	A
		LSB		2		mA
$VBUS\_ADC$	ADC VBUS Voltage Reading	Range	0		18.00	V
		LSB		3.97		mV
$V_{PMID\_ADC}$	ADC PMID Voltage Reading	Range	0		18.00	V
		LSB		3.97		mV
$VBAT\_ADC$	ADC BAT Voltage Reading	Range	0		5.572	V
		LSB		1.99		mV
$VSYS\_ADC$	ADC SYS Voltage Reading	Range	0		5.572	V
		LSB		1.99		mV

## 7.5 Electrical Characteristics (continued)

$V_{VBUS\_UVLOZ} < V_{VBUS} < V_{VBUS\_OVP}$ ,  $T_J = -40^{\circ}\text{C}$  to  $+125^{\circ}\text{C}$ , and  $T_J = 25^{\circ}\text{C}$  for typical values (unless otherwise noted)

PARAMETER		TEST CONDITIONS	MIN	TYP	MAX	UNIT
IBAT_ADC	ADC BAT Current Reading	Range	-7.5		4.0	A
		LSB		4		mA
TS_ADC	ADC TS Voltage Reading	Range as a percent of REGN ( $-40^{\circ}\text{C}$ to $85^{\circ}\text{C}$ for 103AT)	20.9		83.2	%
	ADC TS Voltage Reading	LSB		0.0961		%
TDIE_ADC	ADC Die Temperature Reading	Range	-40		140	$^{\circ}\text{C}$
		LSB		0.5		$^{\circ}\text{C}$
<b>I2C INTERFACE (SCL, SDA)</b>						
$V_{IH}$	Input high threshold level, SDA and SCL		0.78			V
$V_{IL}$	Input low threshold level, SDA and SCL				0.42	V
$V_{OL\_SDA}$	Output low threshold level	Sink current = 5mA, 1.2V VDD			0.3	V
$I_{BIAS}$	High-level leakage current	Pull up rail 1.8V			1	$\mu\text{A}$
$C_{BUS}$	Capacitive load for each bus line				400	pF
<b>LOGIC OUTPUT PIN (INT, PG, STAT)</b>						
$V_{OL}$	Output low threshold level	Sink current = 5mA			0.3	V
$I_{OUT\_BIAS}$	High-level leakage current	Pull up rail 1.8V			1	$\mu\text{A}$
<b>LOGIC INPUT PIN (CE, QON)</b>						
$V_{IH\_CE}$	Input high threshold level, /CE		0.78			V
$V_{IL\_CE}$	Input low threshold level, /CE				0.4	V
$I_{IN\_BIAS\_CE}$	High-level leakage current, /CE	Pull up rail 1.8V			1	$\mu\text{A}$
$V_{IH\_QON}$	Input high threshold level, /QON		1.3			V
$V_{IL\_QON}$	Input low threshold level, /QON				0.4	V
$V_{QON}$	Internal /QON pull up	/QON is pulled up internally.		5.0		V
$R_{QON}$	Internal /QON pull up resistance			250		k $\Omega$

## 7.6 Timing Requirements

PARAMETER		TEST CONDITIONS	MIN	NOM	MAX	UNIT
<b>VBUS / VBAT POWER UP</b>						
$t_{VBUS\_OVP}$	VBUS OVP deglitch time to set VBUS_FAULT_STAT and VBUS_FAULT_FLAG			200		$\mu\text{s}$
$t_{POORSRC}$	Bad adapter detection duration			30		ms
<b>BATTERY CHARGER</b>						
$t_{TOP\_OFF}$	Typical top-off timer accuracy	TOPOFF_TMR = 01	12	17	21	min
		TOPOFF_TMR = 10	24	35	41	min
		TOPOFF_TMR = 11	36	52	61	min
$t_{SAFETY\_TRKCHG}$	Charge safety timer accuracy in trickle charge		0.85	1.25	1.35	hr
$t_{SAFETY\_PRECHG}$	Charge safety timer accuracy in pre-charge	PRECHG_TMR = 0	1.75	2.5	2.75	hr
		PRECHG_TMR = 1	0.43	0.62	0.68	hr
$t_{SAFETY}$	Charge safety timer accuracy in fast charge	CHG_TMR = 0	10.5	14.5	15.5	hr
		CHG_TMR = 1	21.0	28	31	hr
<b>BATFET CONTROL</b>						

## 7.6 Timing Requirements (continued)

PARAMETER		TEST CONDITIONS	MIN	NOM	MAX	UNIT
t <sub>BATFET_DLY</sub>	Time after writing to BATFET_CTRL before BATFET turned off for ship mode or shutdown	BATFET_DLY = 1		12.5		s
		BATFET_DLY = 0		25		ms
t <sub>SM_EXIT</sub>	Deglitch time for $\overline{QON}$ to be pulled low in order to exit from Ship Mode		0.55	0.8	0.93	s
t <sub>QON_RST</sub>	Time $\overline{QON}$ is held low to initiate system power reset		9.0	12.5	14.5	s
t <sub>BATFET_RST</sub>	Duration that BATFET is disabled during system power reset			430		ms
<b>I2C INTERFACE</b>						
f <sub>SCL</sub>	SCL clock frequency	See Serial Interface section for more details.			1.0	MHz
<b>DIGITAL CLOCK AND WATCHDOG</b>						
t <sub>LP_WDT</sub>	Watchdog Reset time (EN_HIZ = 1, WATCHDOG = 11)		100	200		s
t <sub>WDT</sub>	Watchdog Reset time (EN_HIZ = 0, WATCHDOG = 11)		136	200		s

## 7.7 Typical Characteristics

$C_{VBUS} = 1 \mu\text{F}$ ,  $C_{PMID} = 10 \mu\text{F}$ ,  $C_{SYS} = 20 \mu\text{F}$ ,  $C_{BAT} = 1 \mu\text{F}$ ,  $L = 1 \mu\text{H}$  (unless otherwise specified)

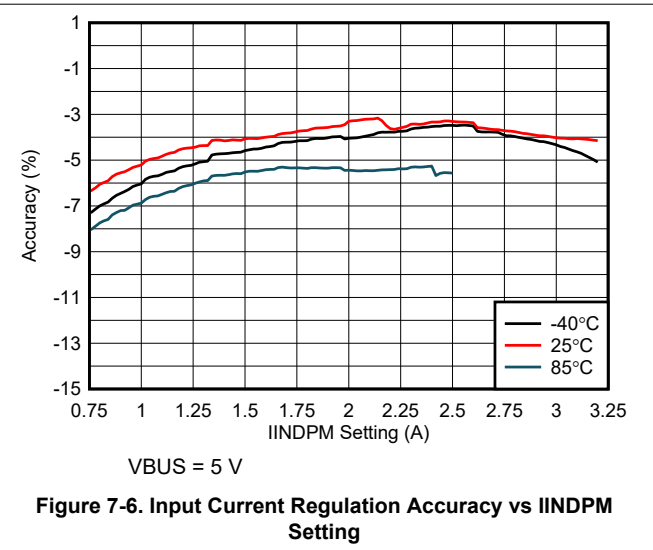
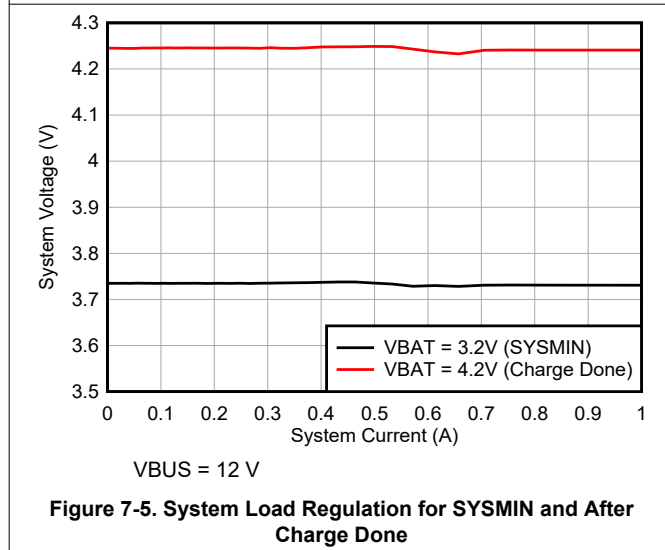
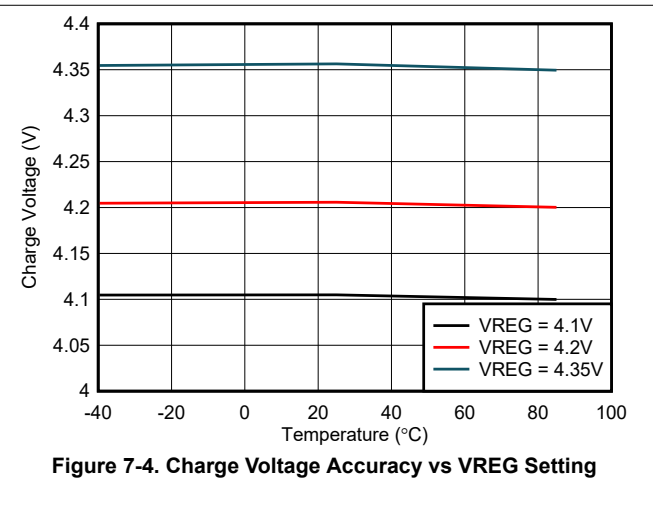
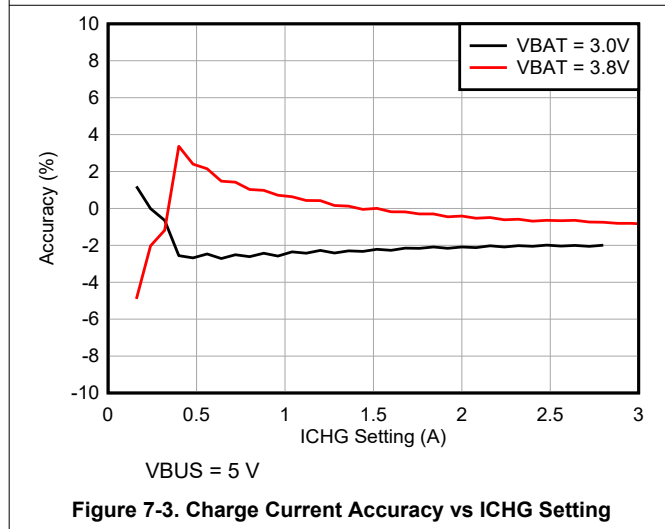
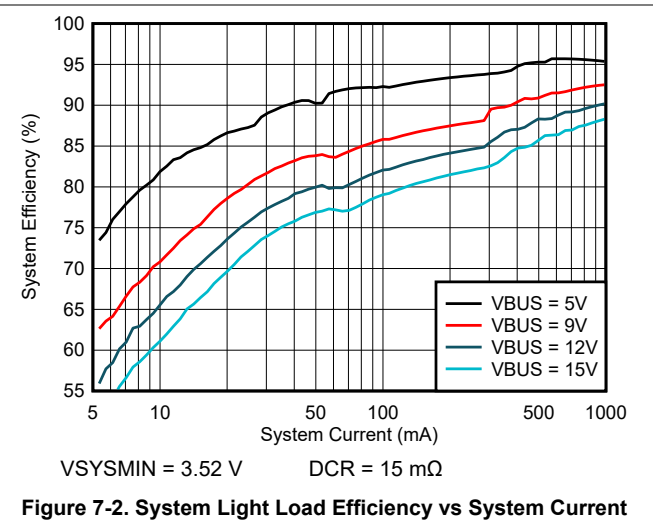
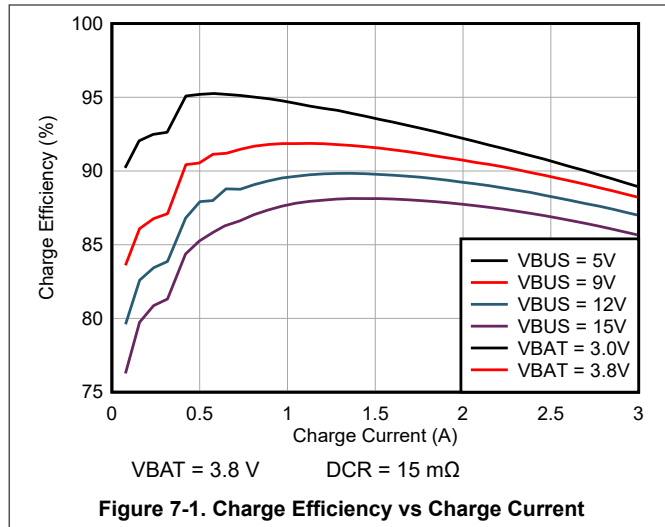

## 8 Detailed Description

### 8.1 Overview

The BQ25622E is a highly-integrated 3-A switch-mode battery charger for single-cell Li-ion and Li-polymer batteries. The device includes input reverse-blocking FET (RBFET, Q1), high-side switching FET (HSFET, Q2), low-side switching FET (LSFET, Q3), battery FET (BATFET, Q4), and bootstrap diode for the high-side gate driver.

## 8.2 Functional Block Diagram

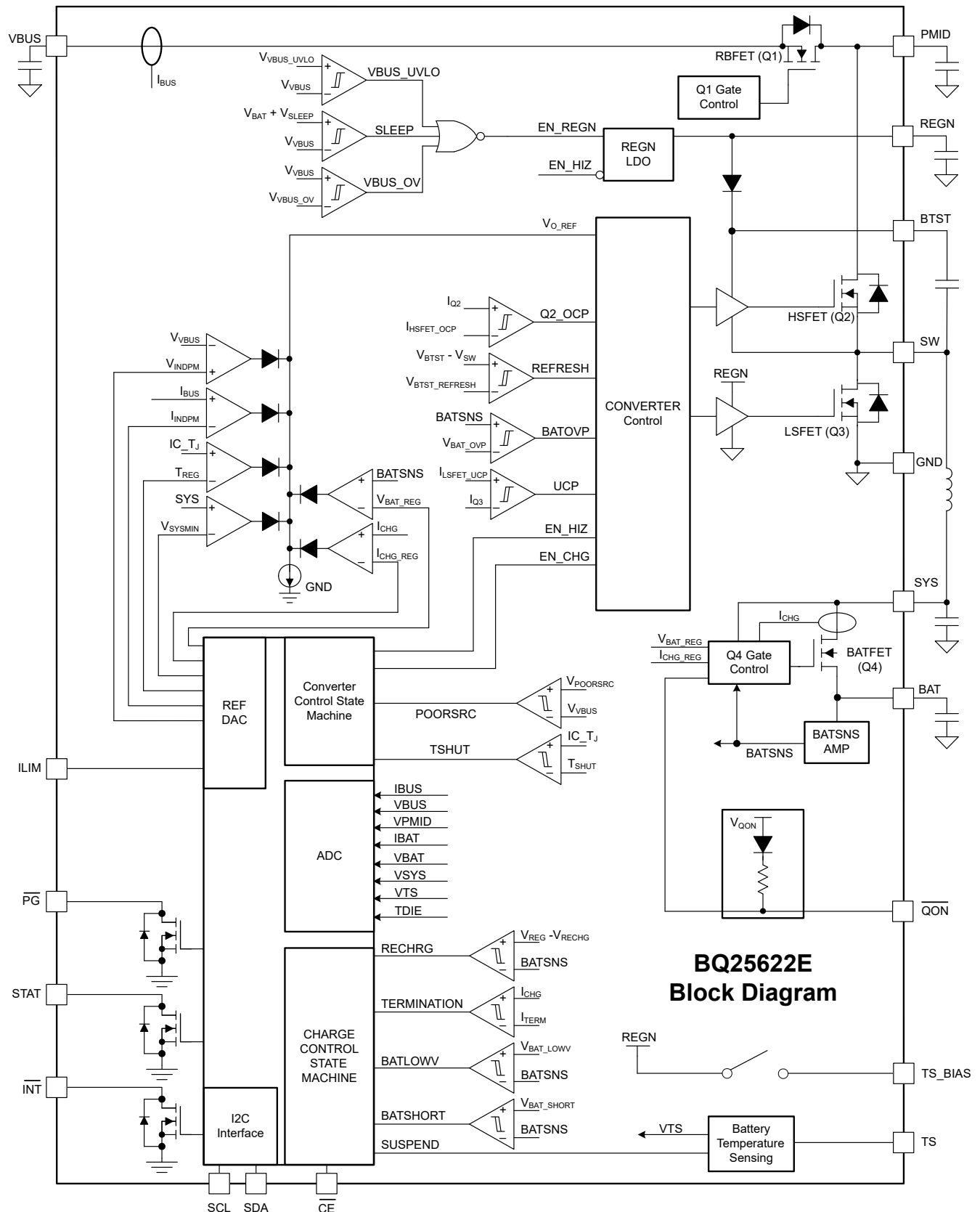

## 8.3 Feature Description

### 8.3.1 Power-On-Reset (POR)

The BQ25622E powers internal bias circuits from the higher voltage of VBUS and BAT. When either voltage rises above its undervoltage lockout (UVLO) threshold, all registers are reset to their POR values and the I<sup>2</sup>C interface is enabled for communication. A non-maskable INT pulse is generated, after which the host can access all of the registers.

### 8.3.2 Device Power Up from Battery

If only the battery is present and the VBAT is above depletion threshold ( $V_{BAT\_UVLOZ}$ ), the BQ25622E performs a power-on reset then turns on the BATFET to connect the battery to system. The REGN LDO output remains off to minimize the quiescent current. The low RDSON of BATFET and the low quiescent current on BAT minimize the conduction loss and maximize the battery run time.

### 8.3.3 Device Power Up from Input Source

When a valid input source is plugged in with  $V_{BAT} < V_{BAT\_UVLOZ}$ , the BQ25622E performs a power-on reset then checks the input source voltage to turn on the REGN LDO and all the bias circuits. It detects and sets the input current limit before the buck converter is started. The power up sequence from input source is as listed:

1. REGN LDO power up ([Section 8.3.3.1](#))
2. Poor source qualification ([Section 8.3.3.2](#))
3. Input voltage limit threshold setting ([Section 8.3.3.4](#))
4. Converter power-up ([Section 8.3.3.5](#))

#### 8.3.3.1 REGN LDO Power Up

The REGN LDO regulator supplies internal bias circuits as well as the HSFET and LSFET gate drive. The REGN LDO also provides bias rail to TS external resistors. The pull-up rail of STAT can be connected to REGN as well. The REGN is enabled when all the below conditions are valid:

- VBUS above  $V_{VBUS\_UVLOZ}$
- VBUS above  $V_{BAT} + V_{SLEEPZ}$
- EN\_HIZ = 0
- After 220-ms delay is completed

If any one of the above conditions is not valid, the REGN LDO and the converter power stage remain off with the converter disabled. In this state, the battery supplies power to the system.

#### 8.3.3.2 Poor Source Qualification

After the REGN LDO powers up, the device checks the current capability of the input source. The input source has to meet the following requirements in order to move forward to the next power on steps.

1. VBUS voltage below  $V_{VBUS\_OVP}$
2. VBUS voltage above  $V_{POORSRC}$  when pulling  $I_{POORSRC}$

Once these conditions are met, the device proceeds to input source type detection.

#### 8.3.3.3 ILIM Pin

The ILIM pin clamps the input current limit to  $I_{INREG} = K_{ILIM} / R_{ILIM}$ , where  $R_{ILIM}$  is connected from the ILIM pin to GND. The ILIM pin can be used to limit the input current limit from 100 mA - 3.2 A. The input current is limited to the lower of the two values set by the ILIM pin and IINDPM register bits. The ILIM pin can also be used to monitor input current. The input current is proportional to the voltage on the ILIM pin and can be calculated by  $I_{IN} = (K_{ILIM} \times V_{ILIM}) / (R_{ILIM} \times 0.8)$ . The ILIM pin function is disabled when the EN\_EXTILIM bit is set to 0.

An RC filter in parallel with  $R_{ILIM}$  is required when the input current setting on the ILIM pin is either:

- below 400 mA or
- above 2 A when using a 2.2- $\mu$ H inductor

The value for the RC filter is 1.2 k $\Omega$  and 330 nF, respectively.

#### 8.3.3.4 Input Voltage Limit Threshold Setting (VINDPM Threshold)

The BQ25622E supports a wide range of input voltage limit (3.8 V – 16.8 V). Its POR default VINDPM threshold is set at 4.6 V. The BQ25622E also supports dynamic VINDPM tracking, which tracks the battery voltage to ensure a sufficient margin between input and battery voltages for proper operation of the buck converter. This function is enabled via the VINDPM\_BAT\_TRACK register bit. When enabled, the actual input voltage limit is the higher of the VINDPM register or  $V_{\text{INDPM\_BAT\_TRACK}}$  ( $V_{\text{BAT}} + 400\text{-mV}$  typical offset.)

#### 8.3.3.5 Converter Power-Up

After the input current and voltage limits are set, the converter is enabled and the HSFET and LSFET start switching. If battery charging is disabled, the BATFET turns off. Otherwise, the BATFET stays on to charge the battery. Converter startup requires the following conditions:

- VBUS has passed poor source qualification (refer to [Section 8.3.3.2](#))
- $V_{\text{BUS}} > V_{\text{BAT}} + V_{\text{SLEEPZ}}$
- $V_{\text{VBUS}} < V_{\text{VBUS\_OVP}}$
- EN\_HIZ = 0
- $V_{\text{SYS}} < V_{\text{SYS\_OVP}}$
- $T_{\text{J}} < T_{\text{SHUT}}$

The BQ25622E provides soft start when the system rail is ramped up by setting IINDPM to its lowest programmable value and stepping up through each available setting until reaching the value set by IINDPM register. Concurrently, the system short protection limits the output current to approximately 0.5 A when the system rail is below  $V_{\text{SYS\_SHORT}}$ .

The device uses a highly efficient 1.5-MHz, fixed frequency pulse width modulated (PWM) step-down switching regulator. The internally compensated feedback loop keep tight control of the switching frequency under all conditions of input voltage, battery voltage, charge current and temperature, simplifying output filter design.

The device switches to pulse frequency modulation (PFM) control at light load condition. The PFM\_FWD\_DIS bit can be used to disable the PFM operation.

### 8.3.4 Power Path Management

The BQ25622E accommodates a wide range of input sources from a USB, wall adapter, wireless charger, to car charger. It provides automatic power path selection to supply the system from an input source, battery, or both.

#### 8.3.4.1 Narrow VDC Architecture

The BQ25622E uses the Narrow VDC architecture (NVDC) with BATFET separating system from battery. The minimum system voltage is set by VSYSTEMIN register setting. Even with a fully depleted battery, the system is regulated to the minimum system voltage. If charging is enabled, the BATFET operates in linear mode (LDO mode). The default minimum system voltage at POR is 3.52 V.

As the battery voltage rises above the minimum system voltage, the BATFET is turned fully on. When battery charging is disabled and  $V_{\text{BAT}}$  is above the minimum system voltage setting, or charging is terminated, the system is regulated 50 mV (typical) above battery voltage.

#### 8.3.4.2 Dynamic Power Management

To meet the USB maximum current limit and avoid overloading the adapter, the device features Dynamic Power Management (DPM), which continuously monitors the input current and input voltage. When the input source is overloaded, either the current exceeds the input current limit (IINDPM) or the voltage falls below the input voltage limit (VINDPM). The device then reduces the charge current until the input current falls below the input current limit and the input voltage rises above the input voltage limit.

When the charge current is reduced to zero, but the input source is still overloaded, the system voltage starts to drop. Once the system voltage falls below the battery voltage by  $V_{\text{SUPP}}$ , the device automatically enters the supplement mode where the BATFET turns on and the battery starts discharging so that the system is supported from both the input source and battery.

### 8.3.4.3 High Impedance Mode

The host may place the BQ25622E into high impedance mode by writing EN\_HIZ = 1. In high impedance mode, RBFET (Q1), HSFET (Q2) and LSFET (Q3) are turned off. The RBFET and HSFET block current flow to and from VBUS, putting the VBUS pin into a high impedance state. The BATFET (Q4) is turned on to connect the BAT to SYS. During high impedance mode, REGN is disabled and the digital clock is slowed to conserve power.

### 8.3.5 Battery Charging Management

The BQ25622E charges a 1-cell Li-Ion battery with up to a 3.0-A charge current. The 15-mΩ BATFET improves charging efficiency and minimizes the voltage drop during discharging.

#### 8.3.5.1 Autonomous Charging Cycle

When battery charging is enabled (EN\_CHG bit = 1 and  $\overline{CE}$  pin is LOW), the BQ25622E autonomously completes a charging cycle without host involvement. The device default charging parameters are listed in [Table 8-1](#). The host can always control the charging operations and optimize the charging parameters by writing to the corresponding registers through I<sup>2</sup>C.

**Table 8-1. Charging Parameter Default Setting**

	VREG	VRECHG	ITRICKLE	IPRECHG	ICHG	ITERM	TOPOFF TIMER
BQ25622E	4.2 V	VREG - 100 mV	20 mA	100 mA	1040 mA	60 mA	Disabled

A new charge cycle starts when the following conditions are valid:

- Converter starts per the conditions in [Section 8.3.3.5](#)
- EN\_CHG = 1
- $\overline{CE}$  pin is low
- No thermistor fault on TS
- No safety timer fault

The BQ25622E automatically terminates the charging cycle when the charging current is below termination threshold, battery voltage is above recharge threshold, and device not is in DPM or thermal regulation. When a fully charged battery is discharged below VRECHG, the device automatically starts a new charging cycle. After charging terminates, toggling  $\overline{CE}$  pin or EN\_CHG bit also initiates a new charging cycle.

The STAT output indicates the charging status. Refer to [Section 8.3.7.3](#) for details of STAT pin operation. In addition, the status register (CHG\_STAT) indicates the different charging phases: 00-charging disabled or terminated, 01-constant current, 10 constant voltage, 11-topoff charging.

#### 8.3.5.2 Battery Charging Profile

The BQ25622E charges the battery in five phases: trickle charge, pre-charge, constant current, constant voltage and an optional top-off charging phase. At the beginning of a charging cycle, the device checks the battery voltage and regulates current and voltage accordingly.

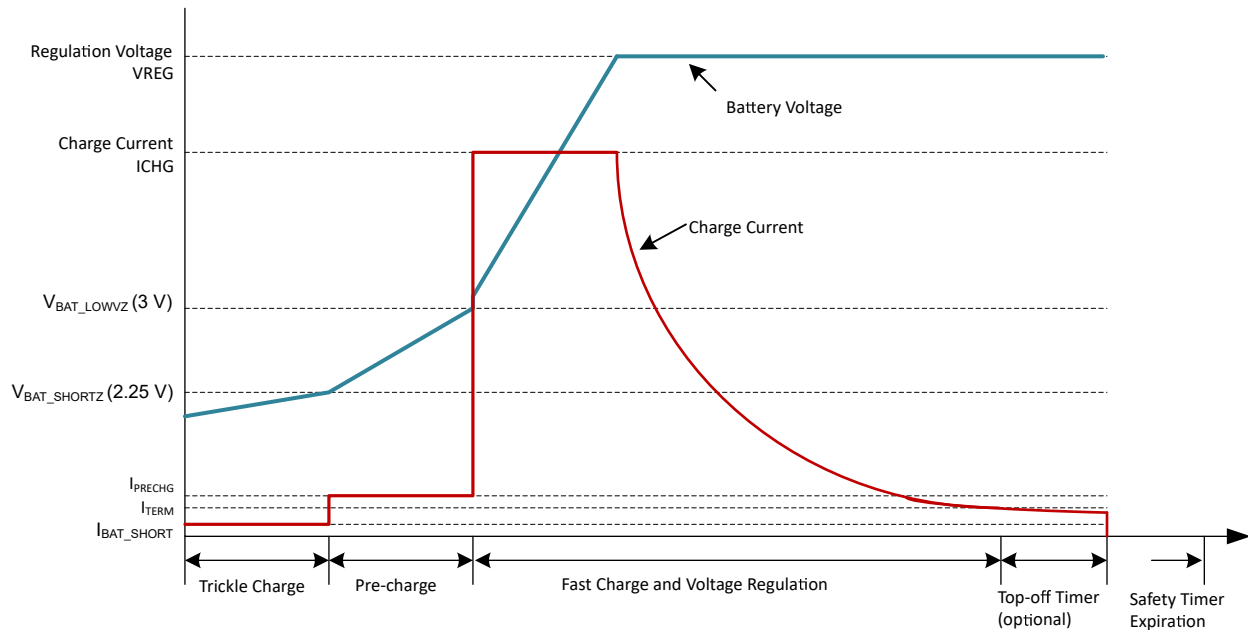

**Figure 8-1. Battery Charging Profile**

### 8.3.5.3 Charging Termination

The BQ25622E terminates a charge cycle when the battery voltage is above recharge threshold, and the current is below  $I_{TERM}$ . To avoid early termination, the BQ25622E does not terminate while  $I_{INDPM}$ ,  $V_{INDPM}$  or thermal regulation loops are active. After the charging cycle is completed, the BATFET turns off. The converter keeps running to power the system, and the BATFET can turn on again to engage supplement mode. Termination can be permanently disabled by writing 0 to  $EN\_TERM$  bit prior to charge termination.

At low termination currents, due to the comparator offset, the actual termination current may be 10 mA to 20 mA higher than the termination target. In order to compensate for comparator offset, a programmable top-off timer can be applied after termination is detected. The top-off timer follows safety timer constraints, such that if the safety timers suspend, so does the top-off timer. Similarly, if the safety timers count at half-clock rate, so does the top-off timer. Refer to [Section 8.3.5.5](#) for the list of conditions. The host can read  $CHG\_STAT$  to find out the termination status.

Top-off timer gets reset by any of the following conditions:

1. Charging cycle stop and restart (toggle CE pin, toggle  $EN\_CHG$  bit, charged battery falls below recharge threshold or adapter removed and replugged)
2. Termination status low to high
3.  $REG\_RST$  register bit is set

The top-off timer settings are read in after is detected by the charger. Programming a top-off timer value after termination has no effect unless a recharge cycle is initiated.  $CHG\_FLAG$  is set to 1 when entering top-off timer segment and again when the top-off timer expires.

### 8.3.5.4 Thermistor Qualification

The BQ25622E provides a single thermistor input for battery temperature monitoring. The TS pin input of the battery temperature can be ignored by the charger if  $TS\_IGNORE = 1$ . When the TS pin feedback is ignored, the charger considers the TS to always be valid for charging mode and  $TS\_STAT$  always reports 000. The TS pin may be left floating if  $TS\_IGNORE$  is set to 1.

When  $TS\_IGNORE=1$ , the  $TS\_ADC$  channel is disabled, with  $TS\_ADC\_DIS$  forced to 1; Attempting to write to 0 is ignored.

When TS\_IGNORE = 0, the charger adjusts the charging profile based on the TS pin feedback information according to the configurable profile described in Section 8.3.5.4.1. When the battery temperature crosses from one temperature range to another, TS\_STAT is updated accordingly, and the charger sets the FLAG bit for the newly-entered temperature range. If TS\_MASK is set to 0, any change to TS\_STAT, including a transition to TS\_NORMAL, generates an INT pulse.

### 8.3.5.4.1 Advanced Temperature Profile in Charge Mode

To improve the safety of charging Li-ion batteries, JEITA guideline was released on April 20, 2007. The guideline emphasized the importance of avoiding a high charge current and high charge voltage at certain low and high temperature ranges. As battery technology continues to evolve, battery manufacturers have released temperature safety specifications that extend beyond the JEITA standard. The BQ25622E features a highly flexible temperature-based charging profile to meet these advanced specifications while remaining backwards compatible with the original JEITA standard. Figure 8-2 shows the programmability for charger behavior under different battery temperature (TS) operating regions.

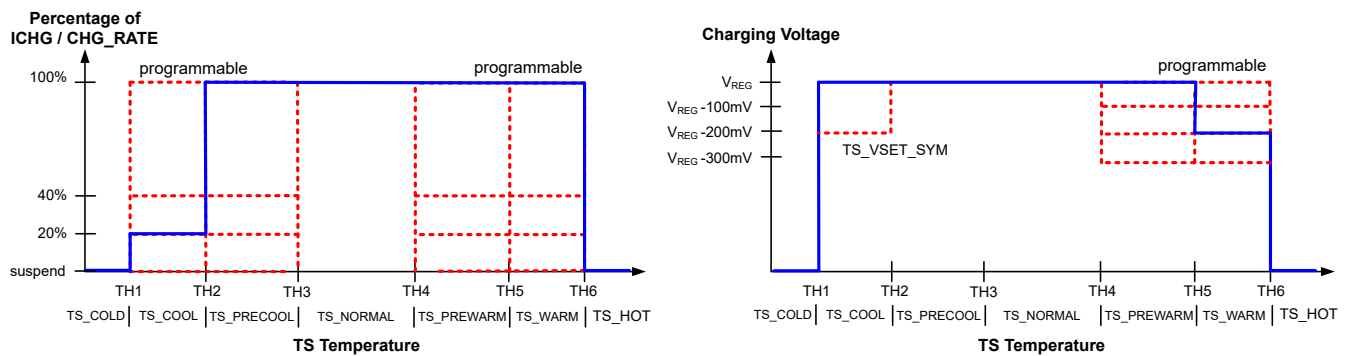

Figure 8-2. TS Charging Values

Charging safety timer is adjusted within the temperature zones to reflect changes to the charging current. When IPRECHG and ICHG are reduced to 20% or 40% in the cool or warm temperature zones, the charging safety timer counts at half rate. If charging is suspended, the safety timer is suspended, the STAT pin blinks and CHG\_STAT is set to 00 (not charging or charge terminated.)

### 8.3.5.4.2 TS Pin Thermistor Configuration

The typical TS resistor network is illustrated below.

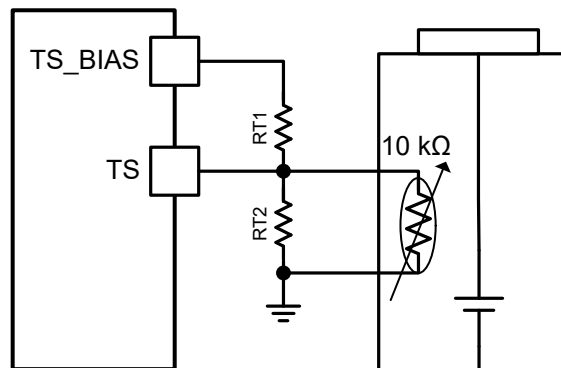

Figure 8-3. TS Resistor Network

The value of RT1 and RT2 are determined from the resistance of the thermistor at 0 and 60°C ( $R_{TH_{0degC}}$  and  $R_{TH_{60degC}}$ ) and the corresponding voltage thresholds  $V_{TS_{0degC}}$  and  $V_{TS_{60degC}}$  (expressed as percentage of REGN with value between 0 and 1). For the most accurate thermistor curve fitting, use the rising threshold

for  $V_{TS\_COLD}$  at 0°C and the falling threshold for  $V_{TS\_HOT}$  at 60°C, regardless of the actual register settings for  $TS\_TH1\_TH2\_TH3$  and  $TS\_TH4\_TH5\_TH6$ .

$$RT2 = \frac{RTH_{0degC} \times RTH_{60degC} \times \left( \frac{1}{V_{TS\_0degC}} - \frac{1}{V_{TS\_60degC}} \right)}{RTH_{60degC} \times \left( \frac{1}{V_{TS\_60degC}} - 1 \right) - RTH_{0degC} \times \left( \frac{1}{V_{TS\_0degC}} - 1 \right)} \quad (1)$$

$$RT1 = \frac{\frac{1}{V_{TS\_0degC}} - 1}{\frac{1}{RT2} + \frac{1}{RTH_{0degC}}} \quad (2)$$

Assuming a 103AT NTC thermistor on the battery pack, the RT1 and RT2 are calculated to be 5.23 kΩ and 30.1 kΩ respectively.

#### 8.3.5.4.3 JEITA Charge Rate Scaling

The  $TS\_ISET\_PRECOOL$ ,  $TS\_ISET\_COOL$ ,  $TS\_ISET\_PREWARM$  and  $TS\_ISET\_WARM$  cool and warm charge current fold backs are based on a 1C charging rate. The 1C rate is the battery capacity in mA-hours divided by 1 hour, so that a 500 mA-hour battery would have a 1C charging rate of 500 mA. The same battery would have a 2C charging rate of 1,000 mA. In order to convert the charging foldback, the host must set the  $CHG\_RATE$  register to the C rate for the battery. This scales the foldback accordingly.

When  $TS\_ISET\_PRECOOL$ ,  $TS\_ISET\_COOL$ ,  $TS\_ISET\_PREWARM$  or  $TS\_ISET\_WARM$  is set to either 00 (suspend) or 11 (unchanged), the  $CHG\_RATE$  setting has no effect. A summary is provided in [Table 8-2](#).

**Table 8-2. ICHG Fold Back**

$TS\_ISET\_PRECOOL$ , $TS\_ISET\_COOL$ , $TS\_ISET\_PREWARM$ or $TS\_ISET\_WARM$	$CHG\_RATE$	FOLD-BACK CURRENT AS PERCENTAGE OF ICHG
00	Any	0% (Suspended)
01 (20%)	00 (1C)	20%
	01 (2C)	10%
	10 (4C)	5%
	11 (6C)	3.3%
10 (40%)	00 (1C)	40%
	01 (2C)	20%
	10 (4C)	10%
	11 (6C)	6.6%
11	Any	100%

#### 8.3.5.4.4 $TS\_BIAS$ Pin

The BQ25622E has the  $TS\_BIAS$  pin to isolate the battery temperature sensing thermistor and associated resistor-divider from  $REGN$ . The 103AT thermistor with typical resistor-divider network requires about 400 μA to bias. The BQ25622E provides the  $TS\_BIAS$  pin, which is internally connected to the  $REGN$  LDO via a back-to-back MOSFET switch. When no temperature measurement is being taken, the switch is disabled to disconnect the thermistor and resistor-divider from the  $REGN$  LDO, saving the 400-μA bias current from being expended unnecessarily.

The  $TS\_BIAS$  pin has short-circuit protection. If a short is detected on the  $TS\_BIAS$  pin, the switch is disabled to disconnect the short from  $REGN$ . If this condition occurs,  $TS\_STAT$  register is set to 0x3. Charging is suspended until the short is removed.

### 8.3.5.5 Charging Safety Timers

The BQ25622E has three built-in safety timers to prevent extended charging cycle due to abnormal battery conditions. The fast charge safety timer and pre-charge safety timers are set through I<sup>2</sup>C CHG\_TMR and PRECHG\_TMR fields, respectively. The trickle charge timer is fixed at 1 hour.

The trickle charging, pre-charging and fast charging safety timers can be disabled by setting EN\_SAFETY\_TMRS = 0. EN\_SAFETY\_TMRS can be enabled anytime regardless of which charging stage the charger is in. Each timer starts to count as soon as the following two conditions are simultaneously true: EN\_SAFETY\_TMRS=1 and the corresponding charging stage is active.

When either the fast charging, trickle charging or pre-charging safety timer expires, the SAFETY\_TMR\_STAT and SAFETY\_TMR\_FLAG bits are set to 1.

Events that cause a reduction in charging current also cause the charging safety timer to count at half-clock rate if TMR2X\_EN bit is set.

During faults which suspend charging, the charge, pre-charge and trickle safety timers are also suspended, regardless of the state of the TMR2X\_EN bit. Once the fault goes away, charging resumes and the safety timer resumes from where it stopped.

The charging safety timer and the charging termination can be disabled at the same time. Under this condition, the charging keeps running until it is disabled by the host.

### 8.3.6 Integrated 12-Bit ADC for Monitoring

The BQ25622E provides an integrated 12-bit ADC for the host to monitor various system parameters.

To enable the ADC, the ADC\_EN bit must be set to '1'. The ADC is disabled by default (ADC\_EN = 0) to conserve power. The ADC is allowed to operate if either VBUS > VPOORSRC or VBAT > VBAT\_LOWV is valid. If ADC\_EN is set to '1' before VBUS or VBAT reach their respective valid thresholds, then ADC\_EN stays '0'. When the charger enters HIZ mode, the ADC is temporarily suspended.

At battery only condition, if the TS\_ADC channel is enabled, the ADC only operates when the battery voltage is higher than 3.2 V (the minimal value to turn on REGN), otherwise, the ADC operates when the battery voltage is higher than V<sub>BAT\_LOWV</sub>.

The ADC\_DONE\_STAT, ADC\_DONE\_FLAG bits are set when a conversion is complete in one-shot mode only. During continuous conversion mode, the ADC\_DONE\_STAT, ADC\_DONE\_FLAG bits have no meaning and remain at 0. In one-shot mode, the ADC\_EN bit is set to 0 at the completion of the conversion, at the same time as the ADC\_DONE\_FLAG bit is set. In continuous mode, the ADC\_EN bit remains at 1 until the user disables the ADC by setting it to 0.

### 8.3.7 Status Outputs ( $\overline{PG}$ , STAT, $\overline{INT}$ )

#### 8.3.7.1 $\overline{PG}$ Pin Power Good Indicator

The  $\overline{PG}$  pin goes LOW to indicate a good input source when:

- V<sub>VBUS</sub> is above V<sub>VBUS\_UVLOZ</sub>
- V<sub>VBUS</sub> is above battery (not in sleep)
- V<sub>VBUS</sub> is below V<sub>VBUS\_OVP</sub> threshold
- V<sub>VBUS</sub> is above V<sub>POORSRC</sub> when I<sub>POORSRC</sub> current is applied (not a poor source)

#### 8.3.7.2 Interrupts and Status, Flag and Mask Bits

The device incorporates an interrupt pin ( $\overline{INT}$ ) to inform a host microcontroller of status changes without requiring microcontroller polling. Each reported event has a status field, a flag bit and a mask bit. The status field reports the status at the time that it is read. The flag bit is latched and, once set to 1, will remain at 1 until the host reads the bit, which will clear it to 0. The mask bit determines whether or not an interrupt pulse will be generated when the flag bit is set.

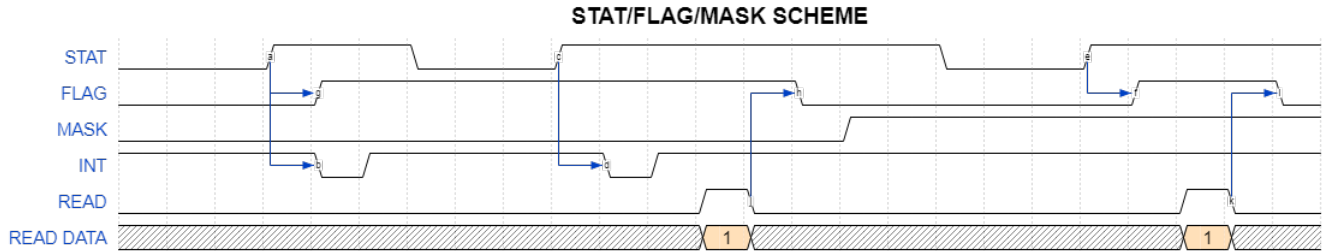

**Figure 8-4. Relationship Between STAT, FLAG, and MASK**

The flag bit is set upon certain transitions of the status field. These transitions also generate an  $\overline{\text{INT}}$  pulse if the associated mask bit is set to 0. Because the  $\overline{\text{INT}}$  is generated from the status field transition and not the flag bit, an  $\overline{\text{INT}}$  pulse is sent to the host even if the associated flag is already set to 1 when the status transition occurs. Details of this behavior are shown in [Figure 8-4](#).

The default behavior is to generate a 256- $\mu\text{s}$   $\overline{\text{INT}}$  pulse when any flag bit is set to 1. These pulses may be masked out on a flag-by-flag basis by setting a flag's mask bit to 1. Setting the mask bit does not affect the transition of the flag bit from 0 to 1, only the generation of the 256- $\mu\text{s}$   $\overline{\text{INT}}$  pulse.

### 8.3.7.3 Charging Status Indicator (STAT)

The BQ25622E indicates charging state on the open drain STAT pin. The STAT pin can drive an LED. The STAT pin function can be disabled via the DIS\_STAT bit.

**Table 8-3. STAT Pin State**

CHARGING STATE	STAT INDICATOR
Charging in progress (including recharge)	LOW
Not charging, no fault detected. (Includes charging complete, Charge Disabled, no adapter present.)	HIGH
Charge suspend	Blinking at 1 Hz

### 8.3.7.4 Interrupt to Host ( $\overline{\text{INT}}$ )

In many applications, the host does not continually poll the charger status registers. Instead, the INT pin may be used to notify the host of a status change with a 256- $\mu\text{s}$   $\overline{\text{INT}}$  pulse. Upon receiving the interrupt pulse, the host may read the flag registers (Charger\_Flag\_X and FAULT\_Flag\_X) to determine the event that caused the interrupt, and for each flagged event, read the corresponding status registers (Charger\_Status\_X and FAULT\_Status\_X) to determine the current state. Once set to 1, the flag bits remain latched at 1 until they are read by the host, which clears them. The status bits, however, are updated whenever there is a change to status and always represent the current state of the system.

All of the  $\overline{\text{INT}}$  events can be masked off to prevent  $\overline{\text{INT}}$  pulses from being sent out when they occur, with the exception of the initial power-up interrupt. Interrupt events are masked by setting their mask bit in registers (Charger\_Mask\_X and FAULT\_Mask\_X). Events always cause the corresponding flag bit to be set to 1, regardless of whether or not the interrupt pulse has been masked.

### 8.3.8 BATFET Control

The BQ25622E has an integrated, bi-directionally blocking BATFET that can be turned off to remove leakage current from the battery to the system. The BATFET is controlled by the BATFET\_CTRL register bits, and supports shutdown mode, ship mode and system power reset.

**Table 8-4. BATFET Control Modes**

MODE	BATFET	I <sup>2</sup> C	ENTRY, NO ADAPTER	ENTRY, WITH ADAPTER, BATFET_CTRL_WVBUS = 0	ENTRY, WITH ADAPTER, BATFET_CTRL_WVBUS = 1	EXIT
Normal	On	Active	N/A	N/A	N/A	N/A

**Table 8-4. BATFET Control Modes (continued)**

MODE	BATFET	I <sup>2</sup> C	ENTRY, NO ADAPTER	ENTRY, WITH ADAPTER, BATFET_CTRL_WVBUS = 0	ENTRY, WITH ADAPTER, BATFET_CTRL_WVBUS = 1	EXIT
Ship mode	Off	Off	Writing BATFET_CTRL = 10 turns off BATFET after BATFET_DLY and enters ship mode.	Writing BATFET_CTRL = 10 has no effect while adapter is present. When both BATFET_DLY has expired and the adapter is removed, the device turns off BATFET and enters ship mode. Writing BATFET_CTRL = 00 before adapter is removed aborts ship mode.	Writing BATFET_CTRL = 10 turns off BATFET after BATFET_DLY. When both BATFET_DLY has expired and adapter is removed, the device enters ship mode. Writing BATFET_CTRL = 00 before adapter is removed turns BATFET on and aborts ship mode.	QON or adapter plug-in
System reset	On to Off to On	Active	Writing BATFET_CTRL = 11 initiates system reset after BATFET_DLY. Holding QON low for t <sub>QON_RST</sub> initiates immediate reset (BATFET_DLY is not applied.)	Writing BATFET_CTRL = 11 is ignored and BATFET_CTRL resets to 00. Holding QON low for t <sub>QON_RST</sub> is ignored.	Writing BATFET_CTRL = 11 initiates system reset after BATFET_DLY. Holding QON low for t <sub>QON_RST</sub> initiates immediate reset. Converter is placed in HIZ during system reset and exits HIZ when system reset completes.	N/A
Shutdown mode	Off	Off	Writing BATFET_CTRL = 01 turns off BATFET after BATFET_DLY and enters shutdown.	Writing BATFET_CTRL = 01 with adapter present is ignored, regardless of BATFET_CTRL_WVBUS setting, and BATFET_CTRL is reset to 00.		Adapter plug-in

### 8.3.8.1 Shutdown Mode

For the lowest battery leakage current, the host can shut down the BQ25622E by setting the register bits BATFET\_CTRL to 01. In this mode, the BATFET is turned off to prevent the battery from powering the system, the I<sup>2</sup>C is disabled and the charger is totally shut down. The BQ25622E can only be woken up by plugging in an adapter. When the adapter is plugged in, the BQ25622E starts back up with all register settings in their POR default.

After the host sets BATFET\_CTRL to 01, the BATFET turns off after waiting either 25 ms or 12.5 s as configured by BATFET\_DLY register bit. Shutdown mode can only be entered when  $V_{VBUS} < V_{VBUS\_UVLO}$ , regardless of the BATFET\_CTRL\_WVBUS setting, which has no effect on shutdown mode entry. If the host writes BATFET\_CTRL = 01 with  $V_{VBUS} > V_{VBUS\_UVLO}$ , the request is ignored and the BATFET\_CTRL bits are set back to 00.

QON has no effect during shutdown mode. The internal pull-up on the QON pin is disabled during shutdown to prevent leakage through the pin.

### 8.3.8.2 Ship Mode

The host may place the BQ25622E into ship mode by setting BATFET\_CTRL = 10. In ship mode, the BATFET is turned off to prevent the battery from powering the system, and the I<sup>2</sup>C is disabled. Ship mode has slightly higher quiescent current than shutdown mode, but QON may be used to exit from ship mode. The BQ25622E is taken out of ship mode by either of these methods:

- Pulling the QON pin low for t<sub>SM\_EXIT</sub>
- $V_{VBUS} > V_{VBUS\_UVLO}$  (adapter plug-in)

When the BQ25622E exits from ship mode, the registers are reset to their POR values.

Ship mode is only entered when the adapter is not present. Setting `BATFET_CTRL = 10` while  $V_{VBUS} > V_{VBUS\_UVLOZ}$  (adapter present) either disables the BATFET or has no immediate effect depending on the setting of `BATFET_CTRL_WVBUS`.

### 8.3.8.3 System Power Reset

The BATFET functions as a load switch between battery and system when the converter is not running. By changing the state of BATFET from on to off, systems connected to SYS can be power cycled. Any of the following conditions initiates a system power reset:

- `BATFET_CTRL_WVBUS = 1` and  $\overline{QON}$  is pulled low for  $t_{QON\_RST}$
- `BATFET_CTRL_WVBUS = 1` and `BATFET_CTRL = 11`
- `BATFET_CTRL_WVBUS = 0` and  $V_{BUS} < V_{VBUS\_UVLO}$  simultaneously with  $\overline{QON}$  pulled low for  $t_{QON\_RST}$
- `BATFET_CTRL_WVBUS = 0` and  $V_{BUS} < V_{VBUS\_UVLO}$  and `BATFET_CTRL = 11`

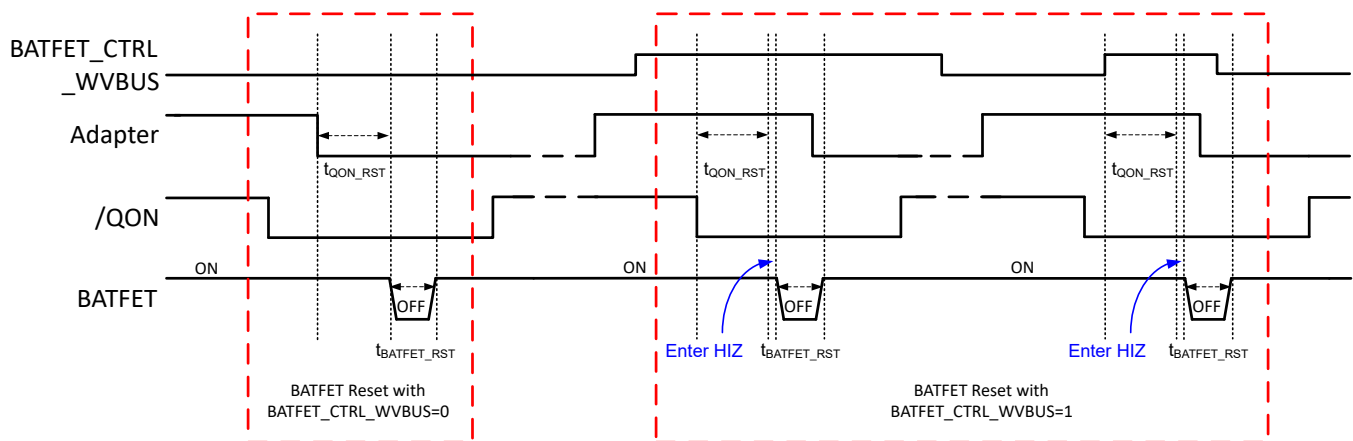

**Figure 8-5. System Power Reset Timing**

When `BATFET_CTRL_WVBUS` is set to 1, system power reset proceeds if either `BATFET_CTRL` is set to 11 or  $\overline{QON}$  is pulled low for  $t_{QON\_RST}$ , regardless of whether  $V_{BUS}$  is present or not. There is a delay of  $t_{BATFET\_DLY}$  before initiating the system power reset. If  $\overline{QON}$  is pulled low, there is no delay after the  $t_{QON\_RST}$  completes, regardless of `BATFET_DLY` setting.

The system power reset can be initiated from the battery only condition or from the forward charging mode with adapter present.

## 8.3.9 Protections

### 8.3.9.1 Voltage and Current Monitoring in Battery Only and HIZ Modes

The BQ25622E monitors a reduced set of voltages and currents when operating from battery without an adapter or when operating from battery in high impedance mode.

#### 8.3.9.1.1 Battery Undervoltage Lockout

In battery-only mode, the BQ25622E disables the BATFET if  $V_{BAT}$  falls below  $V_{BAT\_UVLO}$ , separating the system from the battery. I<sup>2</sup>C is disabled as well. Upon exit from the undervoltage lockout condition when either  $V_{BAT}$  rises above  $V_{BAT\_UVLOZ}$  or  $V_{VBUS}$  rises above  $V_{VBUS\_UVLOZ}$ , I<sup>2</sup>C will be re-enabled and the registers are reset to their POR values.

#### 8.3.9.1.2 Battery Overcurrent Protection

The BQ25622E has a two-level battery overcurrent protection. The  $I_{BAT\_PK}$  threshold is set by `IBAT_PK` and provides a fast (100  $\mu$ s) protection for the battery discharging. `IBATFET_OCP` provides a slower (50 ms), fixed-threshold protection for the BATFET. If the battery discharge current becomes higher than either threshold for its protection timer, the `BAT_FAULT_STAT` and `BAT_FAULT_FLAG` fault register bits are set to 1, and the BATFET

enters hiccup mode with 100-ms off-time and ~1% on-time. The BAT\_FAULT\_STAT will return to 0 once the BATFET is disabled for the hiccup mode. Once the BATFET is turned back on, the I<sub>BAT\_PK</sub> and I<sub>BATFET\_OCP</sub> thresholds are re-evaluated.

### 8.3.9.2 Voltage and Current Monitoring in Buck Mode

#### 8.3.9.2.1 Input Overvoltage

If V<sub>BUS</sub> voltage rises above V<sub>VBUS\_OVP</sub>, the converter stops switching to protect the internal power MOSFETs and I<sub>PMID\_LOAD</sub> discharge current is applied to bring down V<sub>BUS</sub> voltage. V<sub>BUS\_FAULT\_FLAG</sub> and V<sub>BUS\_FAULT\_STAT</sub> are set to 1. When V<sub>BUS</sub> falls back below V<sub>VBUS\_OVPZ</sub>, V<sub>BUS\_FAULT\_STAT</sub> will transition to 0 and the converter will resume switching.

#### 8.3.9.2.2 System Overvoltage Protection (SYSOVP)

When V<sub>SYS</sub> rises above the V<sub>SYS\_OVP</sub> threshold (around 250 mV above V<sub>BAT</sub> when not charging) in forward converter operation, the converter stops switching to limit voltage overshoot and applies I<sub>SYS\_LOAD</sub> to pull down the system voltage. V<sub>SYS\_FAULT\_FLAG</sub> and V<sub>SYS\_FAULT\_STAT</sub> are set to 1. Once V<sub>SYS</sub> drops below V<sub>SYS\_OVP</sub>, the converter resumes switching, the 30 mA discharge current is removed and V<sub>SYS\_FAULT\_STAT</sub> transitions to 0.

#### 8.3.9.2.3 Forward Converter Cycle-by-Cycle Current Limit

The converter has cycle-by-cycle peak overcurrent protection in the switching MOSFETs. In forward mode, if the current through Q2 exceeds I<sub>HSFET\_OCP</sub>, the converter will immediately turn off the high-side gate drive for the remainder of the switching cycle. Normal switching resumes on the next switching cycle.

#### 8.3.9.2.4 System Short

When the SYS voltage falls below V<sub>SYS\_SHORT</sub>, the charger enters PFM operation to limit the output current to approximately 0.5 A or less. SYS\_FAULT\_STAT and SYS\_FAULT\_FLAG bits are set to 1. If V<sub>SYS</sub> rises above V<sub>SYS\_SHORTZ</sub>, the converter exits forced PFM mode, and the SYS\_FAULT\_STAT bit is set to 0.

#### 8.3.9.2.5 Battery Overvoltage Protection (BATOVP)

When V<sub>BAT</sub> transitions above V<sub>BAT\_OVP</sub>, the BQ25622E disables charging by disabling the BATFET and applies I<sub>BAT\_LOAD</sub> current source to discharge excess BAT voltage. If battery voltage remains above the threshold, BAT\_FAULT\_FLAG is set to 1 and BAT\_FAULT\_STAT transitions to 1. Once V<sub>BAT</sub> falls below V<sub>BAT\_OVPZ</sub>, charging resumes and BAT\_FAULT\_STAT transitions back to 0.

#### 8.3.9.2.6 Sleep and Poor Source Comparators

The sleep comparator is used to suspend the converter if the adapter voltage is insufficient to maintain buck converter operation while charging the battery. If V<sub>VBUS</sub> falls below V<sub>BAT</sub> + V<sub>SLEEP</sub>, the converter stops switching, the  $\overline{\text{PG}}$  pin transitions high, and V<sub>BUS\_FAULT\_STAT</sub> and V<sub>BUS\_FAULT\_FLAG</sub> are set to 1. If V<sub>VBUS</sub> rises back above V<sub>BAT</sub> + V<sub>SLEEPZ</sub>, the converter restarts, and the  $\overline{\text{PG}}$  pin transitions low.

If V<sub>VBUS</sub> falls below V<sub>POORSRC</sub>, the converter stops switching and the  $\overline{\text{PG}}$  pin transitions high (if not already suspended and high due to the sleep comparator), and the V<sub>BUS\_STAT</sub> transitions to 000 and the device transitions to battery-only mode. If V<sub>VBUS</sub> rises above V<sub>POORSRC</sub>, it is a new adapter attach, and poor source qualification will be run in addition to D+/D- detection if enabled. V<sub>BUS\_STAT</sub> and the  $\overline{\text{PG}}$  pin state will be determined by the adapter attach sequence as outlined in [Section 8.3.3](#).

### 8.3.9.3 Thermal Regulation and Thermal Shutdown

#### 8.3.9.3.1 Thermal Protection in Buck Mode

The BQ25622E monitors the internal junction temperature T<sub>J</sub> to avoid overheating the chip and limits the IC junction temperature in buck mode. When the internal junction temperature exceeds the T<sub>REG</sub> thermal regulation limit (T<sub>REG</sub> register configuration), the device lowers the charging current. During thermal regulation, the safety timer runs at half the clock rate, and the T<sub>REG\_FLAG</sub> and T<sub>REG\_STAT</sub> bits are set to 1. Additionally, the device has thermal shutdown to turn off the converter and BATFET when IC junction temperature exceeds T<sub>SHUT</sub>. The

fault bit TSHUT\_FLAG is set to 1 and TSHUT\_STAT transitions to 1. The BATFET and converter are re-enabled when IC temperature is  $T_{SHUT\_HYS}$  below  $T_{SHUT}$ , and TSHUT\_STAT transitions to 0.

#### 8.3.9.3.2 Thermal Protection in Battery-Only Mode

The BQ25622E monitors the internal junction temperature  $T_J$  to avoid overheating the chip and limits the IC junction temperature in battery-only mode. The device has thermal shutdown to turn off the BATFET when IC junction temperature exceeds  $T_{SHUT}$ . The fault bit TSHUT\_FLAG is set to 1 and TSHUT\_STAT transitions to 1. The BATFET is re-enabled when IC temperature is  $T_{SHUT\_HYS}$  below  $T_{SHUT}$ , and TSHUT\_STAT transitions to 0.

## 8.4 Device Functional Modes

### 8.4.1 Host Mode and Default Mode

The device is a host controlled charger, but it can operate in default mode without host management. In default mode, the device can be used as an autonomous charger with no host or while host is in sleep mode. When the charger is in default mode, WD\_STAT bit becomes HIGH, WD\_FLAG is set to 1, and an  $\overline{INT}$  is asserted low to alert the host (unless masked by WD\_MASK). The WD\_FLAG bit would read as 1 upon the first read and then 0 upon subsequent reads. When the charger is in host mode, WD\_STAT bit is LOW.

After power-on-reset, the device starts in default mode with watchdog timer expired. All the registers are in the default settings.

In default mode, the device keeps charging the battery with default 1-hour trickle charging safety timer, 2-hour pre-charging safety timer and the 12-hour fast charging safety timer. At the end of the 1-hour or 2-hour or 12-hour timer expired, the charging is stopped and the buck converter continues to operate to supply system load.

A write to any I<sup>2</sup>C register transitions the charger from default mode to host mode, and initiates the watchdog timer. All the device parameters can be programmed by the host. To keep the device in host mode, the host has to reset the watchdog timer by writing 1 to WD\_RST bit before the watchdog timer expires (WD\_STAT bit is set), or disable watchdog timer by setting WATCHDOG bits = 00.

When the watchdog expires, the device returns to default mode. The ICHG value is divided in half when the watchdog timer expires, and a number of other fields are reset to their POR default values as shown in the notes column of the register tables in [Section 8.6](#). When watchdog timer expires, WD\_STAT and WD\_FLAG is set to 1, and an  $\overline{INT}$  is asserted low to alert the host (unless masked by WD\_MASK).

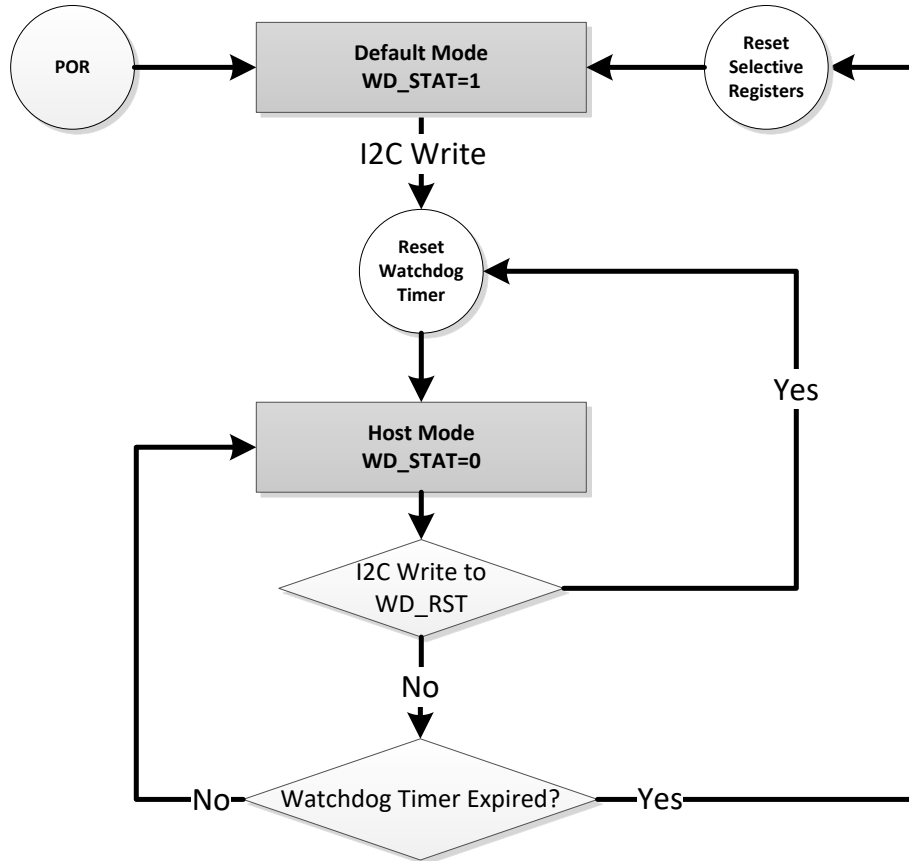

**Figure 8-6. Watchdog Timer Flow Chart**

**8.4.2 Register Bit Reset**

Beside a register reset by the watchdog timer in default mode, the register and the timer can be reset to the default value by writing the REG\_RST bit to 1. The register bits, which can be reset by the REG\_RST bit, are noted in the [Register Map](#) section. After the register reset, the REG\_RST bit goes back from 1 to 0 automatically.

## 8.5 Programming

### 8.5.1 Serial Interface

The BQ25622E uses an I<sup>2</sup>C compatible interface for flexible charging parameter programming and instantaneous device status reporting. I<sup>2</sup>C is a bi-directional 2-wire serial interface. Only two open-drain bus lines are required: a serial data line (SDA), and a serial clock line (SCL).

The device has 7-bit I<sup>2</sup>C address 0x6B, receiving control inputs from a host device such as a micro-controller or digital signal processor through register addresses 0x02 – 0x38. The host device initiates all transfers and the charger responds. Register reads outside of these addresses return 0xFF. When the bus is free, both SDA and SCL lines are HIGH.

The I<sup>2</sup>C interface supports standard mode (up to 100 kbits/s), fast mode (up to 400 kbits/s) and fast mode plus (up to 1 Mbits/s.) These lines are pulled up to a reference voltage via pull-up resistor. The device I<sup>2</sup>C detection thresholds support a communication reference voltage from 1.2 V to 5 V.

Due to the ultra low I<sub>Q</sub> when the device operates in low power mode, it is necessary ensure a minimum of 90µs between a START command and any subsequent START command on the I<sup>2</sup>C bus. The recommended minimum t<sub>buf</sub> (bus free time between a STOP and START condition) depends on the I<sup>2</sup>C mode:

- Standard mode (100 kbits/s):
  - No additional requirements
- Fast mode (400 kbits/s):
  - Increase I<sup>2</sup>C t<sub>buf</sub> to at least 68 µs
  - If using repeated start commands, ensure I<sup>2</sup>C tsu:STA is at least 68 µs
- Fast mode plus (1 Mbits/s):
  - Increase I<sup>2</sup>C t<sub>buf</sub> to at least 81 µs
  - If using repeated start commands, ensure I<sup>2</sup>C tsu:STA is at least 81 µs

These recommendations assume a successful I<sup>2</sup>C transaction. It is also necessary to ensure a minimum 90µs time between two START commands in the case of a NACK.

#### 8.5.1.1 Data Validity

The data on the SDA line must be stable during the HIGH period of the clock. The HIGH or LOW state of the data line can only change when the clock signal on the SCL line is LOW. One clock pulse is generated for each data bit transferred.

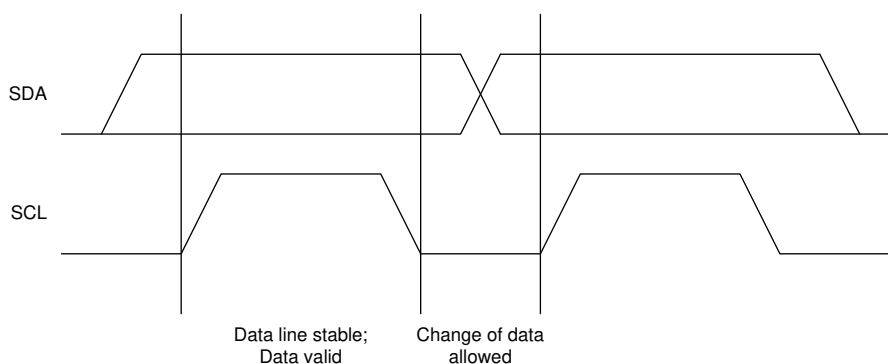
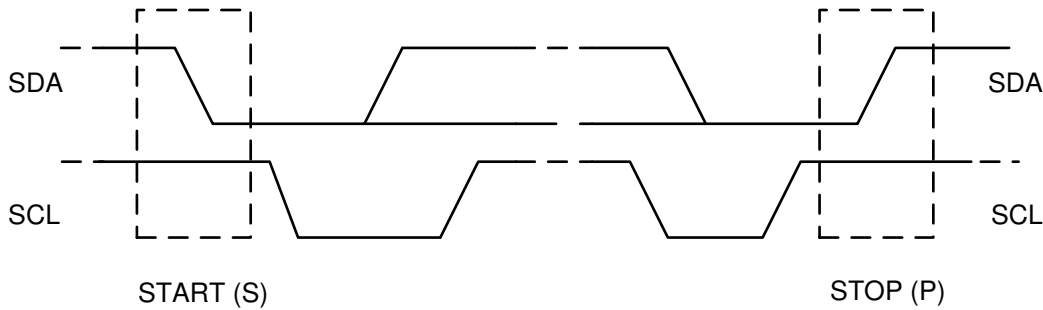

**Figure 8-7. Bit Transfer on the I<sup>2</sup>C Bus**

#### 8.5.1.2 START and STOP Conditions

All transactions begin with a START (S) and are terminated with a STOP (P). A HIGH to LOW transition on the SDA line while SCL is HIGH defines a START condition. A LOW to HIGH transition on the SDA line when the SCL is HIGH defines a STOP condition.

START and STOP conditions are always generated by the host. The bus is considered busy after the START condition, and free after the STOP condition.



**Figure 8-8. START and STOP Conditions on the I<sup>2</sup>C Bus**

### 8.5.1.3 Byte Format

Every byte on the SDA line must be 8 bits long. The number of bytes to be transmitted per transfer is unrestricted. Each byte has to be followed by an ACKNOWLEDGE (ACK) bit. Data is transferred with the Most Significant Bit (MSB) first. If target cannot receive or transmit another complete byte of data until it has performed some other function, it can hold the SCL line low to force the host into a wait state (clock stretching). Data transfer then continues when the target is ready for another byte of data and releases the SCL line.

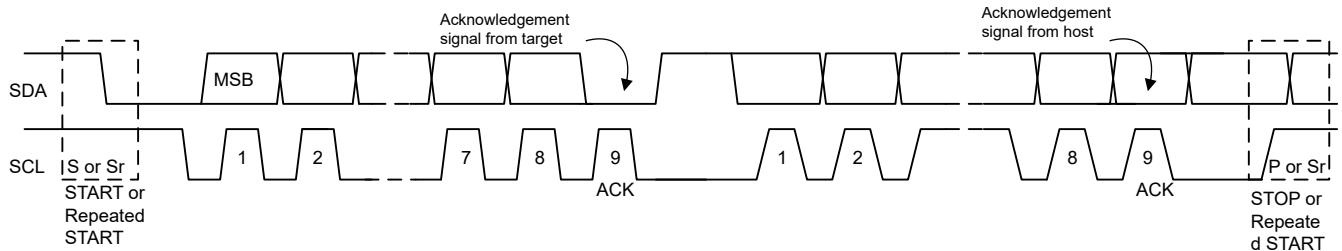

**Figure 8-9. Data Transfer on the I<sup>2</sup>C Bus**

### 8.5.1.4 Acknowledge (ACK) and Not Acknowledge (NACK)

The ACK signaling takes place after each transmitted byte. The ACK bit allows the target to signal the host that the byte was successfully received and another byte may be sent. All clock pulses, including the acknowledge 9<sup>th</sup> clock pulse, are generated by the host.

The host releases the SDA line during the acknowledge clock pulse so the target can pull the SDA line LOW and it remains stable LOW during the HIGH period of this 9<sup>th</sup> clock pulse.

A NACK is signaled when the SDA line remains HIGH during the 9<sup>th</sup> clock pulse. The host can then generate either a STOP to abort the transfer or a repeated START to start a new transfer.

### 8.5.1.5 Target Address and Data Direction Bit

After the START signal, a target address is sent. This address is 7 bits long, followed by the 8 bit as a data direction bit (bit R/W). A zero indicates a transmission (WRITE) and a one indicates a request for data (READ). The device 7-bit address is defined as

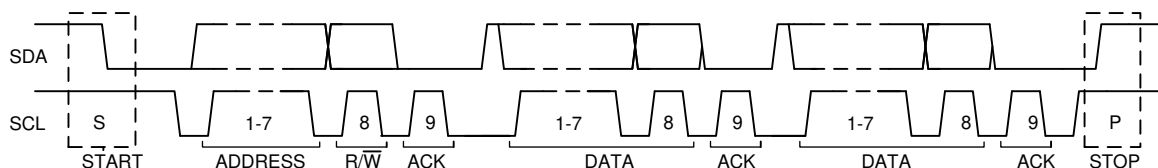

**Figure 8-10. Complete Data Transfer on the I<sup>2</sup>C Bus**



## 8.6 Register Maps

I<sup>2</sup>C Device Address: 0x6B.

### 8.6.1 Register Programming

The BQ25622E contains 8-bit and 16-bit registers. When writing to 16-bit registers, I<sup>2</sup>C transactions follow the little endian format, starting at the address of the least significant byte and writing both register bytes in a single 16-bit transaction.

## 8.6.2 BQ25622E Registers

Table 8-5 lists the memory-mapped registers for the BQ25622E registers. All register offset addresses not listed in Table 8-5 should be considered as reserved locations and the register contents should not be modified.

**Table 8-5. BQ25622E Registers**

Address	Acronym	Register Name	Section
2h	REG0x02_Charge_Current_Limit	Charge Current Limit	<a href="#">Go</a>
4h	REG0x04_Charge_Voltage_Limit	Charge Voltage Limit	<a href="#">Go</a>
6h	REG0x06_Input_Current_Limit	Input Current Limit	<a href="#">Go</a>
8h	REG0x08_Input_Voltage_Limit	Input Voltage Limit	<a href="#">Go</a>
Eh	REG0x0E_Minimal_System_Voltage	Minimal System Voltage	<a href="#">Go</a>
10h	REG0x10_Pre-charge_Control	Pre-charge Control	<a href="#">Go</a>
12h	REG0x12_Termination_Control	Termination Control	<a href="#">Go</a>
14h	REG0x14_Charge_Control_0	Charge Control 0	<a href="#">Go</a>
15h	REG0x15_Charge_Timer_Control	Charge Timer Control	<a href="#">Go</a>
16h	REG0x16_Charger_Control_1	Charger Control 1	<a href="#">Go</a>
17h	REG0x17_Charger_Control_2	Charger Control 2	<a href="#">Go</a>
18h	REG0x18_Charger_Control_3	Charger Control 3	<a href="#">Go</a>
19h	REG0x19_Charger_Control_4	Charger Control 4	<a href="#">Go</a>
1Ah	REG0x1A_NTC_Control_0	NTC Control 0	<a href="#">Go</a>
1Bh	REG0x1B_NTC_Control_1	NTC Control 1	<a href="#">Go</a>
1Ch	REG0x1C_NTC_Control_2	NTC Control 2	<a href="#">Go</a>
1Dh	REG0x1D_Charger_Status_0	Charger Status 0	<a href="#">Go</a>
1Eh	REG0x1E_Charger_Status_1	Charger Status 1	<a href="#">Go</a>
1Fh	REG0x1F_FAULT_Status_0	FAULT Status 0	<a href="#">Go</a>
20h	REG0x20_Charger_Flag_0	Charger Flag 0	<a href="#">Go</a>
21h	REG0x21_Charger_Flag_1	Charger Flag 1	<a href="#">Go</a>
22h	REG0x22_FAULT_Flag_0	FAULT Flag 0	<a href="#">Go</a>
23h	REG0x23_Charger_Mask_0	Charger Mask 0	<a href="#">Go</a>
24h	REG0x24_Charger_Mask_1	Charger Mask 1	<a href="#">Go</a>
25h	REG0x25_FAULT_Mask_0	FAULT Mask 0	<a href="#">Go</a>
26h	REG0x26_ADC_Control	ADC Control	<a href="#">Go</a>
27h	REG0x27_ADC_Function_Disable_0	ADC Function Disable 0	<a href="#">Go</a>
28h	REG0x28_IBUS_ADC	IBUS ADC	<a href="#">Go</a>
2Ah	REG0x2A_IBAT_ADC	IBAT ADC	<a href="#">Go</a>
2Ch	REG0x2C_VBUS_ADC	VBUS ADC	<a href="#">Go</a>
2Eh	REG0x2E_VPMID_ADC	VPMID ADC	<a href="#">Go</a>
30h	REG0x30_VBAT_ADC	VBAT ADC	<a href="#">Go</a>
32h	REG0x32_VSYS_ADC	VSYS ADC	<a href="#">Go</a>
34h	REG0x34_TS_ADC	TS ADC	<a href="#">Go</a>
36h	REG0x36_TDIE_ADC	TDIE ADC	<a href="#">Go</a>
38h	REG0x38_Part_Information	Part Information	<a href="#">Go</a>

Complex bit access types are encoded to fit into small table cells. Table 8-6 shows the codes that are used for access types in this section.

**Table 8-6. BQ25622E Access Type Codes**

Access Type	Code	Description
Read Type		
R	R	Read
Write Type		
W	W	Write
Reset or Default Value		
-n		Value after reset or the default value

**8.6.2.1 REG0x02\_Charge\_Current\_Limit Register (Address = 2h) [Reset = 0340h]**

REG0x02\_Charge\_Current\_Limit is shown in [Figure 8-15](#) and described in [Table 8-7](#).

Return to the [Summary Table](#).

Charge Current Limit

**Figure 8-15. REG0x02\_Charge\_Current\_Limit Register**

15	14	13	12	11	10	9	8
RESERVED						ICHG	
R-0h						R/W-Dh	
7	6	5	4	3	2	1	0
ICHG		RESERVED					
R/W-Dh		R-0h					

**Table 8-7. REG0x02\_Charge\_Current\_Limit Register Field Descriptions**

Bit	Field	Type	Reset	Notes	Description
15:12	RESERVED	R	0h		Reserved
11:6	ICHG	R/W	Dh	WATCHDOG Timer Expiration sets ICHG to 1/2 its previous value (rounded down) Reset by: REG_RESET	Charge Current Regulation Limit: This 16-bit register follows the little-endian convention. ICHG[5:2] falls in REG0x03[3:0], and ICHG[1:0] falls in REG0x02[7:6]. POR: 1040mA (Dh) Range: 80mA-3040mA (1h-26h) Clamped Low Clamped High Bit Step: 80mA (1h) NOTE: When Q4_FULLON=1, this register has a minimum value of 160mA
5:0	RESERVED	R	0h		Reserved

### 8.6.2.2 REG0x04\_Charge\_Voltage\_Limit Register (Address = 4h) [Reset = 0D20h]

REG0x04\_Charge\_Voltage\_Limit is shown in [Figure 8-16](#) and described in [Table 8-8](#).

Return to the [Summary Table](#).

Charge Voltage Limit

**Figure 8-16. REG0x04\_Charge\_Voltage\_Limit Register**

15	14	13	12	11	10	9	8
RESERVED				VREG			
R-0h				R/W-1A4h			
7	6	5	4	3	2	1	0
VREG				RESERVED			
R/W-1A4h				R-0h			

**Table 8-8. REG0x04\_Charge\_Voltage\_Limit Register Field Descriptions**

Bit	Field	Type	Reset	Notes	Description
15:12	RESERVED	R	0h		Reserved
11:3	VREG	R/W	1A4h	Reset by: REG_RESET	Battery Voltage Regulation Limit: This 16-bit register follows the little-endian convention. VREG[8:5] falls in REG0x05[3:0], and VREG[4:0] falls in REG0x04[7:3]. POR: 4200mV (1A4h) Range: 3500mV-4800mV (15Eh-1E0h) Clamped Low Clamped High Bit Step: 10mV
2:0	RESERVED	R	0h		Reserved

### 8.6.2.3 REG0x06\_Input\_Current\_Limit Register (Address = 6h) [Reset = 0A00h]

REG0x06\_Input\_Current\_Limit is shown in [Figure 8-17](#) and described in [Table 8-9](#).

Return to the [Summary Table](#).

Input Current Limit

**Figure 8-17. REG0x06\_Input\_Current\_Limit Register**

15	14	13	12	11	10	9	8
RESERVED				IINDPM			
R-0h				R/W-A0h			
7	6	5	4	3	2	1	0
IINDPM				RESERVED			
R/W-A0h				R-0h			

**Table 8-9. REG0x06\_Input\_Current\_Limit Register Field Descriptions**

Bit	Field	Type	Reset	Notes	Description
15:12	RESERVED	R	0h		Reserved
11:4	IINDPM	R/W	A0h	Reset by: REG_RESET Adapter Removal	Input Current Regulation Limit: This 16-bit register follows the little-endian convention. POR: 3200mA (A0h) Range: 100mA-3200mA (5h-A0h) Clamped Low Clamped High Bit Step: 20mA When the adapter is removed, IINDPM is reset to its POR value of 3.2 A.

**Table 8-9. REG0x06\_Input\_Current\_Limit Register Field Descriptions (continued)**

Bit	Field	Type	Reset	Notes	Description
3:0	RESERVED	R	0h		Reserved

#### 8.6.2.4 REG0x08\_Input\_Voltage\_Limit Register (Address = 8h) [Reset = 0E60h]

REG0x08\_Input\_Voltage\_Limit is shown in [Figure 8-18](#) and described in [Table 8-10](#).

Return to the [Summary Table](#).

Input Voltage Limit

**Figure 8-18. REG0x08\_Input\_Voltage\_Limit Register**

15		14		13		12		11		10		9		8	
RESERVED						VINDPM									
R-0h						R/W-73h									
7		6		5		4		3		2		1		0	
VINDPM						RESERVED									
R/W-73h						R-0h									

**Table 8-10. REG0x08\_Input\_Voltage\_Limit Register Field Descriptions**

Bit	Field	Type	Reset	Notes	Description
15:14	RESERVED	R	0h		Reserved
13:5	VINDPM	R/W	73h		Absolute Input Voltage Regulation Limit: This 16-bit register follows the little-endian convention. VINDPM[8:3] falls in REG0x09[5:0], and VINDPM[2:0] falls in REG0x08[7:5]. POR: 4600mV (73h) Range: 3800mV-16800mV (5Fh-1A4h) Clamped Low Clamped High Bit Step: 40mV
4:0	RESERVED	R	0h		Reserved

#### 8.6.2.5 REG0x0E\_Minimal\_System\_Voltage Register (Address = Eh) [Reset = 0B00h]

REG0x0E\_Minimal\_System\_Voltage is shown in [Figure 8-19](#) and described in [Table 8-11](#).

Return to the [Summary Table](#).

Minimal System Voltage

**Figure 8-19. REG0x0E\_Minimal\_System\_Voltage Register**

15		14		13		12		11		10		9		8	
RESERVED						VSYSMIN									
R-0h						R/W-2Ch									
7		6		5		4		3		2		1		0	
VSYSMIN						RESERVED									
R/W-2Ch						R-0h									

**Table 8-11. REG0x0E\_Minimal\_System\_Voltage Register Field Descriptions**

Bit	Field	Type	Reset	Notes	Description
15:12	RESERVED	R	0h		Reserved

**Table 8-11. REG0x0E\_Minimal\_System\_Voltage Register Field Descriptions (continued)**

Bit	Field	Type	Reset	Notes	Description
11:6	VSYSMIN	R/W	2Ch	Reset by: REG_RESET	Minimal System Voltage: This 16-bit register follows the little-endian convention. VSYSMIN[5:2] falls in REG0x0F[3:0], and VSYSMIN[1:0] falls in REG0x0E[7:6]. POR: 3520mV (2Ch) Range: 2560mV-3840mV (20h-30h) Clamped Low Clamped High Bit Step: 80mV
5:0	RESERVED	R	0h		Reserved

**8.6.2.6 REG0x10\_Pre-charge\_Control Register (Address = 10h) [Reset = 0050h]**

REG0x10\_Pre-charge\_Control is shown in [Figure 8-20](#) and described in [Table 8-12](#).

Return to the [Summary Table](#).

Pre-charge Control

**Figure 8-20. REG0x10\_Pre-charge\_Control Register**

15	14	13	12	11	10	9	8
RESERVED							IPRECHG
R-0h							R/W-5h
7	6	5	4	3	2	1	0
IPRECHG				RESERVED			
R/W-5h				R-0h			

**Table 8-12. REG0x10\_Pre-charge\_Control Register Field Descriptions**

Bit	Field	Type	Reset	Notes	Description
15:9	RESERVED	R	0h		Reserved
8:4	IPRECHG	R/W	5h	Reset by: REG_RESET	Pre-charge current regulation limit: This 16-bit register follows the little-endian convention. IPRECHG[4] falls in REG0x11[0], and IPRECHG[3:0] falls in REG0x10[7:4] POR: 100mA (5h) Range: 20mA-620mA (1h-1Fh) Clamped Low Bit Step: 20mA (1h) NOTE: When Q4_FULLON=1, this register has a minimum value of 80mA
3:0	RESERVED	R	0h		Reserved

### 8.6.2.7 REG0x12\_Termination\_Control Register (Address = 12h) [Reset = 0030h]

REG0x12\_Termination\_Control is shown in [Figure 8-21](#) and described in [Table 8-13](#).

Return to the [Summary Table](#).

Termination Control

**Figure 8-21. REG0x12\_Termination\_Control Register**

15	14	13	12	11	10	9	8
RESERVED							ITERM
R-0h							R/W-6h
7	6	5	4	3	2	1	0
ITERM					RESERVED		
R/W-6h					R-0h		

**Table 8-13. REG0x12\_Termination\_Control Register Field Descriptions**

Bit	Field	Type	Reset	Notes	Description
15:9	RESERVED	R	0h		Reserved
8:3	ITERM	R/W	6h	Reset by: REG_RESET	Termination Current Threshold: This 16-bit register follows the little-endian convention. ITERM[5] falls in REG0x13[0], and ITERM[4:0] falls in REG0x12[7:3]. POR: 60mA (6h) Range: 10mA-620mA (1h-3Eh) Clamped Low Bit Step: 10mA (1h) NOTE: When Q4_FULLLON=1, this register has a minimum value of 120mA, so Reset value becomes 120mA in this case
2:0	RESERVED	R	0h		Reserved

### 8.6.2.8 REG0x14\_Charge\_Control\_0 Register (Address = 14h) [Reset = 06h]

REG0x14\_Charge\_Control\_0 is shown in [Figure 8-22](#) and described in [Table 8-14](#).

Return to the [Summary Table](#).

Charge Control 0

**Figure 8-22. REG0x14\_Charge\_Control\_0 Register**

7	6	5	4	3	2	1	0
Q1_FULLLON	Q4_FULLLON	ITRICKLE	TOPOFF_TMR	EN_TERM	VINDPM_BAT_TRAC K	VRECHG	
R/W-0h	R/W-0h	R/W-0h	R/W-0h	R/W-1h	R/W-1h	R/W-0h	

**Table 8-14. REG0x14\_Charge\_Control\_0 Register Field Descriptions**

Bit	Field	Type	Reset	Notes	Description
7	Q1_FULLLON	R/W	0h		Forces RBFET (Q1) into low resistance state (26 mOhm) , regardless of IINDPM setting. 0b = RBFET RDSON determined by IINDPM setting (default) 1b = RBFET RDSON is always 26 mOhm
6	Q4_FULLLON	R/W	0h		Forces BATFET (Q4) into low resistance state (15 mOhm), regardless of ICHG setting. (Only applies when VBAT > VSYSMIN. Otherwise BATFET operates in linear mode.) 0b = BATFET RDSON determined by charge current (default) 1b = BATFET RDSON is always 15 mOhm

**Table 8-14. REG0x14\_Charge\_Control\_0 Register Field Descriptions (continued)**

Bit	Field	Type	Reset	Notes	Description
5	ITRICKLE	R/W	0h	Reset by: REG_RESET	Trickle charging current setting: 0b = 20mA (default) 1b = 80mA
4:3	TOPOFF_TMR	R/W	0h	Reset by: REG_RESET	Top-off timer control: 00b = Disabled (default) 01b = 17 mins 10b = 35 mins 11b = 52 mins
2	EN_TERM	R/W	1h	Reset by: REG_RESET WATCHDOG	Enable termination 0b = Disable 1b = Enable (default)
1	VINDPM_BAT_TRACK	R/W	1h	Reset by: REG_RESET	Sets VINDPM to track BAT voltage. Actual VINDPM is higher of the VINDPM register value and VBAT + VINDPM_BAT_TRACK. 0b = Disable function (VINDPM set by register) 1b = VBAT + 400 mV (default)
0	VRECHG	R/W	0h	Reset by: REG_RESET	Battery Recharge Threshold Offset (Below VREG) 0b = 100mV (default) 1b = 200mV

**8.6.2.9 REG0x15\_Charge\_Timer\_Control Register (Address = 15h) [Reset = 0Ch]**

REG0x15\_Charge\_Timer\_Control is shown in [Figure 8-23](#) and described in [Table 8-15](#).

Return to the [Summary Table](#).

Charge Timer Control

**Figure 8-23. REG0x15\_Charge\_Timer\_Control Register**

7	6	5	4	3	2	1	0
DIS_STAT	RESERVED			TMR2X_EN	EN_SAFETY_TMRS	PRECHG_TMR	CHG_TMR
R/W-0h	R-0h			R/W-1h	R/W-1h	R/W-0h	R/W-0h

**Table 8-15. REG0x15\_Charge\_Timer\_Control Register Field Descriptions**

Bit	Field	Type	Reset	Notes	Description
7	DIS_STAT	R/W	0h	Reset by: REG_RESET	Disable the STAT pin output 0b = Enable (default) 1b = Disable
6:4	RESERVED	R	0h		Reserved
3	TMR2X_EN	R/W	1h	Reset by: REG_RESET	2X charging timer control 0b = Trickle charge, pre-charge and fast charge timer not slowed by 2X during input DPM or thermal regulation. 1b = Trickle charge, pre-charge and fast charge timer slowed by 2X during input DPM or thermal regulation (default)
2	EN_SAFETY_TMRS	R/W	1h	Reset by: REG_RESET WATCHDOG	Enable fast charge, pre-charge and trickle charge timers 0b = Disable 1b = Enable (default)
1	PRECHG_TMR	R/W	0h	Reset by: REG_RESET	Pre-charge safety timer setting 0b = 2.5 hrs (default) 1b = 0.62 hrs
0	CHG_TMR	R/W	0h	Reset by: REG_RESET	Fast charge safety timer setting 0b = 14.5 hrs (default) 1b = 28 hrs

### 8.6.2.10 REG0x16\_Charger\_Control\_1 Register (Address = 16h) [Reset = A1h]

REG0x16\_Charger\_Control\_1 is shown in [Figure 8-24](#) and described in [Table 8-16](#).

Return to the [Summary Table](#).

Charger Control 1

**Figure 8-24. REG0x16\_Charger\_Control\_1 Register**

7	6	5	4	3	2	1	0
EN_AUTO_IBATDIS	FORCE_IBATDIS	EN_CHG	EN_HIZ	FORCE_P MID_DIS	WD_RST	WATCHDOG	
R/W-1h	R/W-0h	R/W-1h	R/W-0h	R/W-0h	R/W-0h	R/W-1h	

**Table 8-16. REG0x16\_Charger\_Control\_1 Register Field Descriptions**

Bit	Field	Type	Reset	Notes	Description
7	EN_AUTO_IBATDIS	R/W	1h	Reset by: REG_RESET	Enable the auto battery discharging during the battery OVP fault 0b = The charger does NOT apply a discharging current on BAT during battery OVP triggered 1b = The charger does apply a discharging current on BAT during battery OVP triggered (default)
6	FORCE_IBATDIS	R/W	0h	Reset by: REG_RESET WATCHDOG	Force a battery discharging current (~30mA) 0b = IDLE (default) 1b = Force the charger to apply a discharging current on BAT
5	EN_CHG	R/W	1h	Reset by: REG_RESET WATCHDOG	Charger enable configuration 0b = Charge Disable 1b = Charge Enable (default)
4	EN_HIZ	R/W	0h	Reset by: REG_RESET WATCHDOG Adapter Plug In	Enable HIZ mode. 0b = Disable (default) 1b = Enable
3	FORCE_P MID_DIS	R/W	0h	Reset by: REG_RESET WATCHDOG	Force a PMID discharge current (~30mA.) 0b = Disable (default) 1b = Enable
2	WD_RST	R/W	0h	Reset by: REG_RESET	I2C watch dog timer reset 0b = Normal (default) 1b = Reset (this bit goes back to 0 after timer reset)
1:0	WATCHDOG	R/W	1h	Reset by: REG_RESET	Watchdog timer setting 00b = Disable 01b = 50s (default) 10b = 100s 11b = 200s

### 8.6.2.11 REG0x17\_Charger\_Control\_2 Register (Address = 17h) [Reset = 4Fh]

REG0x17\_Charger\_Control\_2 is shown in [Figure 8-25](#) and described in [Table 8-17](#).

Return to the [Summary Table](#).

Charger Control 2

**Figure 8-25. REG0x17\_Charger\_Control\_2 Register**

7	6	5	4	3	2	1	0
REG_RST	TREG	SET_CONV_FREQ	SET_CONV_STRN	RESERVED	VBUS_OVP		
R/W-0h	R/W-1h	R/W-0h	R/W-3h	R-0h	R/W-1h		

**Table 8-17. REG0x17\_Charger\_Control\_2 Register Field Descriptions**

Bit	Field	Type	Reset	Notes	Description
7	REG_RST	R/W	0h	REG_RESET	Reset registers to default values and reset timer Value resets to 0 after reset completes. 0b = Not reset (default) 1b = Reset
6	TREG	R/W	1h	Reset by: REG_RESET	Thermal regulation thresholds. 0b = 60C 1b = 120C (default)
5:4	SET_CONV_FREQ	R/W	0h	Reset by: REG_RESET	Adjust switching frequency of the converter 00b = Nominal, 1.5 MHz (default) 01b = -10%, 1.35 MHz 10b = +10%, 1.65 MHz 11b = RESERVED
3:2	SET_CONV_STRN	R/W	3h	Reset by: REG_RESET	Adjust the high side and low side drive strength of the converter to adjust efficiency versus EMI. 00b = weak 01b = normal 10b = RESERVED 11b = strong
1	RESERVED	R	0h		Reserved
0	VBUS_OVP	R/W	1h	Reset by: REG_RESET	Sets VBUS overvoltage protection threshold 0b = 6.3 V 1b = 18.5 V

**8.6.2.12 REG0x18\_Charger\_Control\_3 Register (Address = 18h) [Reset = 04h]**

REG0x18\_Charger\_Control\_3 is shown in [Figure 8-26](#) and described in [Table 8-18](#).

Return to the [Summary Table](#).

Charger Control 3

**Figure 8-26. REG0x18\_Charger\_Control\_3 Register**

7	6	5	4	3	2	1	0
RESERVED			PFM_FWD_DIS	BATFET_CTRL_WV BUS	BATFET_DLY	BATFET_CTRL	
R-0h			R/W-0h	R/W-0h	R/W-1h	R/W-0h	

**Table 8-18. REG0x18\_Charger\_Control\_3 Register Field Descriptions**

Bit	Field	Type	Reset	Notes	Description
7:5	RESERVED	R	0h		Reserved
4	PFM_FWD_DIS	R/W	0h	Reset by: REG_RESET	Disable PFM in forward buck mode 0b = Enable (Default) 1b = Disable
3	BATFET_CTRL_WV BUS	R/W	0h		Optionally allows BATFET off or system power reset with adapter present. 0b = Allow BATFET off or system power reset only if VBUS < VVBUS_UVLO. (default) 1b = Allow BATFET off or system power reset whether or not VBUS < VVBUS_UVLO.
2	BATFET_DLY	R/W	1h	Reset by: REG_RESET	Delay time added to the taking action in bits [1:0] of the BATFET_CTRL 0b = Add 25 ms delay time 1b = Add 12.5 s delay time (default)

**Table 8-18. REG0x18\_Charger\_Control\_3 Register Field Descriptions (continued)**

Bit	Field	Type	Reset	Notes	Description
1:0	BATFET_CTRL	R/W	0h	Reset by: REG_RESET	BATFET control The control logic of the BATFET to force the device enter different modes. 00b = Normal (default) 01b = Shutdown Mode 10b = Ship Mode 11b = System Power Reset

### 8.6.2.13 REG0x19\_Charger\_Control\_4 Register (Address = 19h) [Reset = C0h]

REG0x19\_Charger\_Control\_4 is shown in [Figure 8-27](#) and described in [Table 8-19](#).

Return to the [Summary Table](#).

Charger Control 4

**Figure 8-27. REG0x19\_Charger\_Control\_4 Register**

7	6	5	4	3	2	1	0
IBAT_PK	VBAT_UVLO	RESERVED		EN_EXTILIM	CHG_RATE		
R/W-3h	R/W-0h	R-0h		R/W-0h	R/W-0h		

**Table 8-19. REG0x19\_Charger\_Control\_4 Register Field Descriptions**

Bit	Field	Type	Reset	Notes	Description
7:6	IBAT_PK	R/W	3h	Reset by: REG_RESET	Battery discharging peak current protection threshold setting 00b = RESERVED 01b = RESERVED 10b = 6A 11b = 12A (default)
5	VBAT_UVLO	R/W	0h	Reset by: REG_RESET	Select the VBAT_UVLO falling threshold and VBAT_SHORT threshold 0b = VBAT_UVLO 2.2V, VBAT_SHORT 2.05V (default) 1b = VBAT_UVLO 1.8V, VBAT_SHORT 1.85V
4:3	RESERVED	R	0h		Reserved
2	EN_EXTILIM	R/W	0h	Reset by: REG_RESET WATCHDOG	Enable the external ILIM pin input current regulation 0b = Disabled 1b = Enabled (default)
1:0	CHG_RATE	R/W	0h	Reset by: REG_RESET	The charge rate definition for the fast charge stage. The charging current fold back value is equal to ICHG register setting times the fold back ratio, then divided by the charge rate. 00b = 1C (default) 01b = 2C 10b = 4C 11b = 6C

### 8.6.2.14 REG0x1A\_NTC\_Control\_0 Register (Address = 1Ah) [Reset = 0Dh]

REG0x1A\_NTC\_Control\_0 is shown in [Figure 8-28](#) and described in [Table 8-20](#).

Return to the [Summary Table](#).

NTC Control 0

**Figure 8-28. REG0x1A\_NTC\_Control\_0 Register**

7	6	5	4	3	2	1	0
TS_IGNORE	RESERVED			TS_ISET_WARM		TS_ISET_COOL	
R/W-0h	R-0h			R/W-3h		R/W-1h	

**Table 8-20. REG0x1A\_NTC\_Control\_0 Register Field Descriptions**

Bit	Field	Type	Reset	Notes	Description
7	TS_IGNORE	R/W	0h	Reset by: REG_RESET WATCHDOG	Ignore the TS feedback: the charger considers the TS is always good to allow charging, TS_STAT reports TS_NORMAL condition. 0b = Not ignore (Default) 1b = Ignore
6:4	RESERVED	R	0h		Reserved
3:2	TS_ISET_WARM	R/W	3h	Reset by: REG_RESET	TS_WARM Current Setting 00b = Charge Suspend 01b = Set ICHG to 20% 10b = Set ICHG to 40% 11b = ICHG unchanged (default)
1:0	TS_ISET_COOL	R/W	1h	Reset by: REG_RESET	TS_COOL Current Setting 00b = Charge Suspend 01b = Set ICHG to 20% (default) 10b = Set ICHG to 40% 11b = ICHG unchanged

### 8.6.2.15 REG0x1B\_NTC\_Control\_1 Register (Address = 1Bh) [Reset = 25h]

REG0x1B\_NTC\_Control\_1 is shown in [Figure 8-29](#) and described in [Table 8-21](#).

Return to the [Summary Table](#).

NTC Control 1

**Figure 8-29. REG0x1B\_NTC\_Control\_1 Register**

7	6	5	4	3	2	1	0
TS_TH1_TH2_TH3			TS_TH4_TH5_TH6			TS_VSET_WARM	
R/W-1h			R/W-1h			R/W-1h	

**Table 8-21. REG0x1B\_NTC\_Control\_1 Register Field Descriptions**

Bit	Field	Type	Reset	Notes	Description
7:5	TS_TH1_TH2_TH3	R/W	1h	Reset by: REG_RESET	TH1, TH2 and TH3 comparator falling temperature thresholds when a 103AT NTC thermistor is used, RT1=5.24kΩ and RT2=30.31kΩ. 000b = TH1 is 0°C, TH2 is 5°C, TH3 is 15°C 001b = TH1 is 0°C, TH2 is 10°C, TH3 is 15°C (default) 010b = TH1 is 0°C, TH2 is 15°C, TH3 is 20°C 011b = TH1 is 0°C, TH2 is 20°C, TH3 is 20°C 100b = TH1 is -5°C, TH2 is 5°C, TH3 is 15°C 101b = TH1 is -5°C, TH2 is 10°C, TH3 is 15°C 110b = TH1 is -5°C, TH2 is 10°C, TH3 is 20°C 111b = TH1 is 0°C, TH2 is 10°C, TH3 is 20°C

**Table 8-21. REG0x1B\_NTC\_Control\_1 Register Field Descriptions (continued)**

Bit	Field	Type	Reset	Notes	Description
4:2	TS_TH4_TH5_TH6	R/W	1h	Reset by: REG_RESET	TH4, TH5 and TH6 comparator rising temperature thresholds when a 103AT NTC thermistor is used, RT1=5.24kΩ and RT2=30.31kΩ. 000b = TH4 is 35°C, TH5 is 40°C, TH6 is 60°C 001b = TH4 is 35°C, TH5 is 45°C, TH6 is 60°C (default) 010b = TH4 is 35°C, TH5 is 50°C, TH6 is 60°C 011b = TH4 is 40°C, TH5 is 55°C, TH6 is 60°C 100b = TH4 is 35°C, TH5 is 40°C, TH6 is 50°C 101b = TH4 is 35°C, TH5 is 45°C, TH6 is 50°C 110b = TH4 is 40°C, TH5 is 45°C, TH6 is 60°C 111b = TH4 is 40°C, TH5 is 50°C, TH6 is 60°C
1:0	TS_VSET_WARM	R/W	1h	Reset by: REG_RESET	TS_WARM Voltage Setting 00b = Set VREG to VREG-300mV 01b = Set VREG to VREG-200mV (default) 10b = Set VREG to VREG-100mV 11b = VREG unchanged

**8.6.2.16 REG0x1C\_NTC\_Control\_2 Register (Address = 1Ch) [Reset = 3Fh]**

REG0x1C\_NTC\_Control\_2 is shown in [Figure 8-30](#) and described in [Table 8-22](#).

Return to the [Summary Table](#).

NTC Control 2

**Figure 8-30. REG0x1C\_NTC\_Control\_2 Register**

7	6	5	4	3	2	1	0
RESERVED	TS_VSET_SYM	TS_VSET_PREWARM		TS_ISET_PREWARM		TS_ISET_PRECOOL	
R-0h	R/W-0h	R/W-3h		R/W-3h		R/W-3h	

**Table 8-22. REG0x1C\_NTC\_Control\_2 Register Field Descriptions**

Bit	Field	Type	Reset	Notes	Description
7	RESERVED	R	0h		RESERVED
6	TS_VSET_SYM	R/W	0h	Reset by: REG_RESET	When this bit is set to 0, the voltage regulation for TS_PRECOOL and TS_COOL is unchanged. When this bit is set to 1, TS_PRECOOL uses the TS_VSET_PREWARM setting of TS_PREWARM and TS_COOL uses the TS_VSET_WARM setting of TS_WARM. 00b = VREG unchanged (default) 01b = TS_COOLx matches TS_WARMx
5:4	TS_VSET_PREWARM	R/W	3h	Reset by: REG_RESET	Advanced temperature profile voltage setting for TS_PREWARM (TH4 - TH5) 00b = Set VREG to VREG-300mV 01b = Set VREG to VREG-200mV 10b = Set VREG to VREG-100mV 11b = VREG unchanged (default)
3:2	TS_ISET_PREWARM	R/W	3h	Reset by: REG_RESET	Advanced temperature profile current setting for TS_PREWARM zone(TH4 - TH5) 00b = Charge Suspend 01b = Set ICHG to 20% 10b = Set ICHG to 40% 11b = ICHG unchanged (default)

**Table 8-22. REG0x1C\_NTC\_Control\_2 Register Field Descriptions (continued)**

Bit	Field	Type	Reset	Notes	Description
1:0	TS_ISET_PRECOOL	R/W	3h	Reset by: REG_RESET	Advanced temperature profile current setting for TS_PRECOOL zone (TH2 - TH3) 00b = Charge Suspend 01b = Set ICHG to 20% 10b = Set ICHG to 40% 11b = ICHG unchanged (default)

**8.6.2.17 REG0x1D\_Charger\_Status\_0 Register (Address = 1Dh) [Reset = 00h]**

REG0x1D\_Charger\_Status\_0 is shown in [Figure 8-31](#) and described in [Table 8-23](#).

Return to the [Summary Table](#).

Charger Status 0

**Figure 8-31. REG0x1D\_Charger\_Status\_0 Register**

7	6	5	4	3	2	1	0
RESERVED	ADC_DONE_STAT	TREG_STAT	VSYS_STAT	IINDPM_STAT	VINDPM_STAT	SAFETY_TMR_STAT	WD_STAT
R-0h	R-0h	R-0h	R-0h	R-0h	R-0h	R-0h	R-0h

**Table 8-23. REG0x1D\_Charger\_Status\_0 Register Field Descriptions**

Bit	Field	Type	Reset	Notes	Description
7	RESERVED	R	0h		Reserved
6	ADC_DONE_STAT	R	0h		ADC Conversion Status (in one-shot mode only) Note: Always reads 0 in continuous mode 0b = Conversion not complete 1b = Conversion complete
5	TREG_STAT	R	0h		IC Thermal regulation status 0b = Normal 1b = Device in thermal regulation
4	VSYS_STAT	R	0h		VSYS Regulation Status (forward mode) 0b = Not in VSYSMIN regulation (BAT>VSYSMIN) 1b = In VSYSMIN regulation (BAT<VSYSMIN)
3	IINDPM_STAT	R	0h		In forward mode, indicates that either IINDPM regulation is active or ILIM pin regulation is active 0b = Normal 1b = In IINDPM/ILIM regulation
2	VINDPM_STAT	R	0h		VINDPM status (forward mode) 0b = Normal 1b = In VINDPM regulation
1	SAFETY_TMR_STAT	R	0h		Fast charge, trickle charge and pre-charge timer status 0b = Normal 1b = Safety timer expired
0	WD_STAT	R	0h		I2C watch dog timer status 0b = Normal 1b = WD timer expired

### 8.6.2.18 REG0x1E\_Charger\_Status\_1 Register (Address = 1Eh) [Reset = 00h]

REG0x1E\_Charger\_Status\_1 is shown in [Figure 8-32](#) and described in [Table 8-24](#).

Return to the [Summary Table](#).

Charger Status 1

**Figure 8-32. REG0x1E\_Charger\_Status\_1 Register**

7	6	5	4	3	2	1	0
RESERVED			CHG_STAT		VBUS_STAT		
R-0h			R-0h		R-0h		

**Table 8-24. REG0x1E\_Charger\_Status\_1 Register Field Descriptions**

Bit	Field	Type	Reset	Notes	Description
7:5	RESERVED	R	0h		Reserved
4:3	CHG_STAT	R	0h		Charge Status bits 00b = Not Charging or Charge Terminated 01b = Trickle Charge, Pre-charge or Fast charge (CC mode) 10b = Taper Charge (CV mode) 11b = Top-off Timer Active Charging
2:0	VBUS_STAT	R	0h		VBUS status bits 000b = Not powered from VBUS 100b = Unknown Adapter (default IINDPM setting)

### 8.6.2.19 REG0x1F\_FAULT\_Status\_0 Register (Address = 1Fh) [Reset = 00h]

REG0x1F\_FAULT\_Status\_0 is shown in [Figure 8-33](#) and described in [Table 8-25](#).

Return to the [Summary Table](#).

FAULT Status 0

**Figure 8-33. REG0x1F\_FAULT\_Status\_0 Register**

7	6	5	4	3	2	1	0
VBUS_FAULT_STAT	BAT_FAULT_STAT	SYS_FAULT_STAT	RESERVED	TSHUT_STAT	TS_STAT		
R-0h	R-0h	R-0h	R-0h	R-0h	R-0h		

**Table 8-25. REG0x1F\_FAULT\_Status\_0 Register Field Descriptions**

Bit	Field	Type	Reset	Notes	Description
7	VBUS_FAULT_STAT	R	0h		VBUS fault status, VBUS OVP and sleep comparator 0b = Normal 1b = Device not switching due to over voltage protection or sleep comparator
6	BAT_FAULT_STAT	R	0h		BAT fault status, IBAT OCP and VBAT OVP 0b = Normal 1b = Device in battery over current protection or battery overvoltage protection
5	SYS_FAULT_STAT	R	0h		VSYS under voltage and over voltage status 0b = Normal 1b = SYS in SYS short circuit or over voltage
4	RESERVED	R	0h		Reserved
3	TSHUT_STAT	R	0h		IC temperature shutdown status 0b = Normal 1b = Device in thermal shutdown protection

**Table 8-25. REG0x1F\_FAULT\_Status\_0 Register Field Descriptions (continued)**

Bit	Field	Type	Reset	Notes	Description
2:0	TS_STAT	R	0h		The TS temperature zone. 000b = TS_NORMAL 001b = TS_COLDor TS resistor string power rail is not available. 010b = TS_HOT 011b = TS_COOL 100b = TS_WARM 101b = TS_PRECOOL 110b = TS_PREWARM 111b = TS pin bias reference fault

**8.6.2.20 REG0x20\_Charger\_Flag\_0 Register (Address = 20h) [Reset = 00h]**

REG0x20\_Charger\_Flag\_0 is shown in [Figure 8-34](#) and described in [Table 8-26](#).

Return to the [Summary Table](#).

Charger Flag 0

**Figure 8-34. REG0x20\_Charger\_Flag\_0 Register**

7	6	5	4	3	2	1	0
RESERVED	ADC_DONE_FLAG	TREG_FLAG	VSYS_FLAG	IINDPM_FLAG	VINDPM_FLAG	SAFETY_TMR_FLAG	WD_FLAG
R-0h	R-0h	R-0h	R-0h	R-0h	R-0h	R-0h	R-0h

**Table 8-26. REG0x20\_Charger\_Flag\_0 Register Field Descriptions**

Bit	Field	Type	Reset	Notes	Description
7	RESERVED	R	0h		Reserved
6	ADC_DONE_FLAG	R	0h		ADC conversion flag (only in one-shot mode) 0b = Conversion not completed 1b = Conversion completed
5	TREG_FLAG	R	0h		IC Thermal regulation flag 0b = Normal 1b = TREG signal rising threshold detected
4	VSYS_FLAG	R	0h		VSYS min regulation flag 0b = Normal 1b = Entered or existed VSYS min regulation
3	IINDPM_FLAG	R	0h		Indicates that either the IINDPM regulation loop or ILIM pin regulation has been entered. 0b = Normal 1b = IINDPM or ILIM regulation signal rising edge detected
2	VINDPM_FLAG	R	0h		VINDPM flag 0b = Normal 1b = VINDPM regulation signal rising edge detected
1	SAFETY_TMR_FLAG	R	0h		Fast charge, trickle charge and pre-charge timer flag 0b = Normal 1b = Fast charge timer expired rising edge detected
0	WD_FLAG	R	0h		I2C watchdog timer flag 0b = Normal 1b = WD timer signal rising edge detected

**8.6.2.21 REG0x21\_Charger\_Flag\_1 Register (Address = 21h) [Reset = 00h]**

REG0x21\_Charger\_Flag\_1 is shown in [Figure 8-35](#) and described in [Table 8-27](#).

Return to the [Summary Table](#).

### Charger Flag 1

**Figure 8-35. REG0x21\_Charger\_Flag\_1 Register**

7	6	5	4	3	2	1	0
RESERVED			CHG_FLAG	RESERVED			VBUS_FLAG
R-0h			R-0h	R-0h			R-0h

**Table 8-27. REG0x21\_Charger\_Flag\_1 Register Field Descriptions**

Bit	Field	Type	Reset	Notes	Description
7:4	RESERVED	R	0h		Reserved
3	CHG_FLAG	R	0h		Charge status flag 0b = Normal 1b = Charge status changed
2:1	RESERVED	R	0h		Reserved
0	VBUS_FLAG	R	0h		VBUS status flag 0b = Normal 1b = VBUS status changed

### 8.6.2.22 REG0x22\_FAULT\_Flag\_0 Register (Address = 22h) [Reset = 00h]

REG0x22\_FAULT\_Flag\_0 is shown in [Figure 8-36](#) and described in [Table 8-28](#).

Return to the [Summary Table](#).

### FAULT Flag 0

**Figure 8-36. REG0x22\_FAULT\_Flag\_0 Register**

7	6	5	4	3	2	1	0
VBUS_FAULT_FLAG	BAT_FAULT_FLAG	SYS_FAULT_FLAG	RESERVED	TSHUT_FLAG	RESERVED		TS_FLAG
R-0h	R-0h	R-0h	R-0h	R-0h	R-0h		R-0h

**Table 8-28. REG0x22\_FAULT\_Flag\_0 Register Field Descriptions**

Bit	Field	Type	Reset	Notes	Description
7	VBUS_FAULT_FLAG	R	0h		VBUS over-voltage or sleep flag 0b = Normal 1b = Entered VBUS OVP or sleep
6	BAT_FAULT_FLAG	R	0h		IBAT over-current and VBAT over-voltage flag 0b = Normal 1b = Entered battery discharged OCP or VBAT OVP
5	SYS_FAULT_FLAG	R	0h		VSYS over voltage and SYS short flag 0b = Normal 1b = Stopped switching due to system over-voltage or SYS short fault
4	RESERVED	R	0h		Reserved
3	TSHUT_FLAG	R	0h		IC thermal shutdown flag 0b = Normal 1b = TS shutdown signal rising threshold detected
2:1	RESERVED	R	0h		Reserved
0	TS_FLAG	R	0h		TS status flag 0b = Normal 1b = A change to TS status was detected

### 8.6.2.23 REG0x23\_Charger\_Mask\_0 Register (Address = 23h) [Reset = 00h]

REG0x23\_Charger\_Mask\_0 is shown in [Figure 8-37](#) and described in [Table 8-29](#).

Return to the [Summary Table](#).

Charger Mask 0

**Figure 8-37. REG0x23\_Charger\_Mask\_0 Register**

7	6	5	4	3	2	1	0
RESERVED	ADC_DONE_MASK	TREG_MASK	VSYS_MASK	IINDPM_MASK	VINDPM_MASK	SAFETY_TMR_MAS K	WD_MASK
R-0h	R/W-0h	R/W-0h	R/W-0h	R/W-0h	R/W-0h	R/W-0h	R/W-0h

**Table 8-29. REG0x23\_Charger\_Mask\_0 Register Field Descriptions**

Bit	Field	Type	Reset	Notes	Description
7	RESERVED	R	0h		Reserved
6	ADC_DONE_MASK	R/W	0h	Reset by: REG_RESET	ADC conversion mask flag (only in one-shot mode) 0b = ADC conversion done does produce $\overline{\text{INT}}$ pulse 1b = ADC conversion done does not produce $\overline{\text{INT}}$ pulse
5	TREG_MASK	R/W	0h	Reset by: REG_RESET	IC thermal regulation mask flag 0b = Entering TREG does produce $\overline{\text{INT}}$ 1b = Entering TREG does not produce $\overline{\text{INT}}$
4	VSYS_MASK	R/W	0h	Reset by: REG_RESET	VSYS min regulation mask flag 0b = Enter or exit VSYSMIN regulation does produce $\overline{\text{INT}}$ pulse 1b = Enter or exit VSYSMIN regulation does not produce $\overline{\text{INT}}$ pulse
3	IINDPM_MASK	R/W	0h	Reset by: REG_RESET	IINDPM or ILIM mask 0b = Enter IINDPM or ILIM does produce $\overline{\text{INT}}$ pulse 1b = Enter IINDPM or ILIM does not produce $\overline{\text{INT}}$ pulse
2	VINDPM_MASK	R/W	0h	Reset by: REG_RESET	VINDPM mask 0b = Enter VINDPM does produce $\overline{\text{INT}}$ pulse 1b = Enter VINDPM does not produce $\overline{\text{INT}}$ pulse
1	SAFETY_TMR_MAS K	R/W	0h	Reset by: REG_RESET	Fast charge, trickle charge and pre-charge timer mask flag 0b = Fast charge, trickle charge or pre-charge timer expiration does produce $\overline{\text{INT}}$ 1b = Fast charge, trickle charge or pre-charge timer expiration does not produce $\overline{\text{INT}}$
0	WD_MASK	R/W	0h	Reset by: REG_RESET	I2C watch dog timer mask 0b = I2C watch dog timer expired does produce $\overline{\text{INT}}$ pulse 1b = I2C watch dog timer expired does not produce $\overline{\text{INT}}$ pulse

#### 8.6.2.24 REG0x24\_Charger\_Mask\_1 Register (Address = 24h) [Reset = 00h]

REG0x24\_Charger\_Mask\_1 is shown in [Figure 8-38](#) and described in [Table 8-30](#).

Return to the [Summary Table](#).

Charger Mask 1

**Figure 8-38. REG0x24\_Charger\_Mask\_1 Register**

7	6	5	4	3	2	1	0
RESERVED				CHG_MASK	RESERVED		VBUS_MASK
R-0h				R/W-0h	R-0h		R/W-0h

**Table 8-30. REG0x24\_Charger\_Mask\_1 Register Field Descriptions**

Bit	Field	Type	Reset	Notes	Description
7:4	RESERVED	R	0h		Reserved

**Table 8-30. REG0x24\_Charger\_Mask\_1 Register Field Descriptions (continued)**

Bit	Field	Type	Reset	Notes	Description
3	CHG_MASK	R/W	0h	Reset by: REG_RESET	Charge status mask flag 0b = Charging status change does produce $\overline{\text{INT}}$ 1b = Charging status change does not produce $\overline{\text{INT}}$
2:1	RESERVED	R	0h		Reserved
0	VBUS_MASK	R/W	0h	Reset by: REG_RESET	VBUS status mask flag 0b = VBUS status change does produce $\overline{\text{INT}}$ 1b = VBUS status change does not produce $\overline{\text{INT}}$

### 8.6.2.25 REG0x25\_FAULT\_Mask\_0 Register (Address = 25h) [Reset = 00h]

REG0x25\_FAULT\_Mask\_0 is shown in [Figure 8-39](#) and described in [Table 8-31](#).

Return to the [Summary Table](#).

FAULT Mask 0

**Figure 8-39. REG0x25\_FAULT\_Mask\_0 Register**

7	6	5	4	3	2	1	0
VBUS_FAULT_MAS K	BAT_FAULT_MASK	SYS_FAULT_MASK	RESERVED	TSHUT_MASK	RESERVED		TS_MASK
R/W-0h	R/W-0h	R/W-0h	R-0h	R/W-0h	R-0h		R/W-0h

**Table 8-31. REG0x25\_FAULT\_Mask\_0 Register Field Descriptions**

Bit	Field	Type	Reset	Notes	Description
7	VBUS_FAULT_MAS K	R/W	0h	Reset by: REG_RESET	VBUS over-voltage and sleep comparator mask flag 0b = Entering VBUS OVP or sleep does produce $\overline{\text{INT}}$ 1b = Entering VBUS OVP or sleep does not produce $\overline{\text{INT}}$
6	BAT_FAULT_MASK	R/W	0h	Reset by: REG_RESET	IBAT over current and VBAT overvoltage mask flag 0b = IBAT OCP fault or VBAT OVP fault does produce $\overline{\text{INT}}$ 1b = Neither IBAT OCP fault nor VBAT OVP fault produces $\overline{\text{INT}}$
5	SYS_FAULT_MASK	R/W	0h	Reset by: REG_RESET	SYS over voltage and SYS short mask 0b = System over-voltage or SYS short fault does produce $\overline{\text{INT}}$ 1b = Neither system over voltage nor SYS short fault produces $\overline{\text{INT}}$
4	RESERVED	R	0h		Reserved
3	TSHUT_MASK	R/W	0h	Reset by: REG_RESET	IC thermal shutdown mask flag 0b = TSHUT does produce $\overline{\text{INT}}$ 1b = TSHUT does not produce $\overline{\text{INT}}$
2:1	RESERVED	R	0h		
0	TS_MASK	R/W	0h	Reset by: REG_RESET	Temperature charging profile interrupt mask 0b = A change to TS temperature zone does produce $\overline{\text{INT}}$ 1b = A change to the TS temperature zone does not produce $\overline{\text{INT}}$

### 8.6.2.26 REG0x26\_ADC\_Control Register (Address = 26h) [Reset = 30h]

REG0x26\_ADC\_Control is shown in [Figure 8-40](#) and described in [Table 8-32](#).

Return to the [Summary Table](#).

ADC Control

**Figure 8-40. REG0x26\_ADC\_Control Register**

7	6	5	4	3	2	1	0
ADC_EN	ADC_RATE	ADC_SAMPLE		ADC_AVG	ADC_AVG_INIT	RESERVED	
R/W-0h	R/W-0h	R/W-3h		R/W-0h	R/W-0h	R-0h	

**Table 8-32. REG0x26\_ADC\_Control Register Field Descriptions**

Bit	Field	Type	Reset	Notes	Description
7	ADC_EN	R/W	0h	Reset by: REG_RESET WATCHDOG	ADC Control The registers POR to all 0 's, then after that always retain the last measurement, and never clear. 0b = Disable (default) 1b = Enable
6	ADC_RATE	R/W	0h	Reset by: REG_RESET	ADC conversion rate control 0b = Continuous conversion (default) 1b = One shot conversion
5:4	ADC_SAMPLE	R/W	3h	Reset by: REG_RESET	ADC sample speed 00b = 12 bit effective resolution 01b = 11 bit effective resolution 10b = 10 bit effective resolution 11b = 9 bit effective resolution (default)
3	ADC_AVG	R/W	0h	Reset by: REG_RESET	ADC average control 0b = Single value (default) 1b = Running average
2	ADC_AVG_INIT	R/W	0h	Reset by: REG_RESET	ADC average initial value control 0b = Start average using the existing register value (default) 1b = Start average using a new ADC conversion
1:0	RESERVED	R	0h		Reserved

**8.6.2.27 REG0x27\_ADC\_Function\_Disable\_0 Register (Address = 27h) [Reset = 00h]**

REG0x27\_ADC\_Function\_Disable\_0 is shown in [Figure 8-41](#) and described in [Table 8-33](#).

Return to the [Summary Table](#).

ADC Function Disable 0

**Figure 8-41. REG0x27\_ADC\_Function\_Disable\_0 Register**

7	6	5	4	3	2	1	0
IBUS_ADC_DIS	IBAT_ADC_DIS	VBUS_ADC_DIS	VBAT_ADC_DIS	VSYS_ADC_DIS	TS_ADC_DIS	TDIE_ADC_DIS	VPMID_ADC_DIS
R/W-0h	R/W-0h	R/W-0h	R/W-0h	R/W-0h	R/W-0h	R/W-0h	R/W-0h

**Table 8-33. REG0x27\_ADC\_Function\_Disable\_0 Register Field Descriptions**

Bit	Field	Type	Reset	Notes	Description
7	IBUS_ADC_DIS	R/W	0h	Reset by: REG_RESET	IBUS ADC control 0b = Enable (Default) 1b = Disable
6	IBAT_ADC_DIS	R/W	0h	Reset by: REG_RESET	IBAT ADC control 0b = Enable (Default) 1b = Disable
5	VBUS_ADC_DIS	R/W	0h	Reset by: REG_RESET	VBUS ADC control 0b = Enable (Default) 1b = Disable
4	VBAT_ADC_DIS	R/W	0h	Reset by: REG_RESET	VBAT ADC control 0b = Enable (Default) 1b = Disable
3	VSYS_ADC_DIS	R/W	0h	Reset by: REG_RESET	VSYS ADC control 0b = Enable (Default) 1b = Disable

**Table 8-33. REG0x27\_ADC\_Function\_Disable\_0 Register Field Descriptions (continued)**

Bit	Field	Type	Reset	Notes	Description
2	TS_ADC_DIS	R/W	0h	Reset by: REG_RESET	TS ADC control 0b = Enable (Default) 1b = Disable
1	TDIE_ADC_DIS	R/W	0h	Reset by: REG_RESET	TDIE ADC control 0b = Enable (Default) 1b = Disable
0	VPMID_ADC_DIS	R/W	0h	Reset by: REG_RESET	VPMID ADC control 0b = Enable (Default) 1b = Disable

### 8.6.2.28 REG0x28\_IBUS\_ADC Register (Address = 28h) [Reset = 0000h]

REG0x28\_IBUS\_ADC is shown in [Figure 8-42](#) and described in [Table 8-34](#).

Return to the [Summary Table](#).

IBUS ADC

**Figure 8-42. REG0x28\_IBUS\_ADC Register**

15	14	13	12	11	10	9	8
IBUS_ADC							
R-0h							
7	6	5	4	3	2	1	0
IBUS_ADC						RESERVED	
R-0h						R-0h	

**Table 8-34. REG0x28\_IBUS\_ADC Register Field Descriptions**

Bit	Field	Type	Reset	Notes	Description
15:1	IBUS_ADC	R	0h		IBUS ADC reading Reported in 2 's Complement. When the current is flowing from VBUS to PMID, IBUS ADC reports positive value. POR: 0mA (0h) Format: 2s Complement Range: -4000mA-4000mA (7830h-7FFFh), (0h-7D0h) Clamped Low Clamped High Bit Step: 2mA
0	RESERVED	R	0h		Reserved

### 8.6.2.29 REG0x2A\_IBAT\_ADC Register (Address = 2Ah) [Reset = 0000h]

REG0x2A\_IBAT\_ADC is shown in [Figure 8-43](#) and described in [Table 8-35](#).

Return to the [Summary Table](#).

IBAT ADC

**Figure 8-43. REG0x2A\_IBAT\_ADC Register**

15	14	13	12	11	10	9	8
IBAT_ADC							
R-0h							
7	6	5	4	3	2	1	0
IBAT_ADC						RESERVED	
R-0h						R-0h	

**Table 8-35. REG0x2A\_IBAT\_ADC Register Field Descriptions**

Bit	Field	Type	Reset	Notes	Description
15:2	IBAT_ADC	R	0h		IBAT ADC reading Reported in 2 's Complement. The IBAT ADC reports positive value for the battery charging current, and negative value for the battery discharging current. The IBAT ADC resets to zero when EN_CHG=0. POR: 0mA (0h) Format: 2s Complement Range: -7500mA-4000mA (38ADh-3FFFh), (0h-3E8h) Clamped Low Clamped High Bit Step: 4mA The IBAT ADC current can only be positive or zero in forward mode, and negative or zero in battery-only mode. If polarity of battery current changes from charging to discharging or vice-versa during the ADC measurement, the conversion is aborted and the register reports code 0x8000 (which is code 0x2000 for IBAT_ADC field)
1:0	RESERVED	R	0h		Reserved

**8.6.2.30 REG0x2C\_VBUS\_ADC Register (Address = 2Ch) [Reset = 0000h]**

REG0x2C\_VBUS\_ADC is shown in [Figure 8-44](#) and described in [Table 8-36](#).

Return to the [Summary Table](#).

VBUS ADC

**Figure 8-44. REG0x2C\_VBUS\_ADC Register**

15	14	13	12	11	10	9	8
RESERVED		VBUS_ADC					
R-0h		R-0h					
7	6	5	4	3	2	1	0
VBUS_ADC						RESERVED	
R-0h						R-0h	

**Table 8-36. REG0x2C\_VBUS\_ADC Register Field Descriptions**

Bit	Field	Type	Reset	Notes	Description
15	RESERVED	R	0h		Reserved
14:2	VBUS_ADC	R	0h		VBUS ADC reading POR: 0mV (0h) Range: 0mV-18000mV (0h-11B6h) Clamped High Bit Step: 3.97mV
1:0	RESERVED	R	0h		Reserved

### 8.6.2.31 REG0x2E\_VPMID\_ADC Register (Address = 2Eh) [Reset = 0000h]

REG0x2E\_VPMID\_ADC is shown in [Figure 8-45](#) and described in [Table 8-37](#).

Return to the [Summary Table](#).

VPMID ADC

**Figure 8-45. REG0x2E\_VPMID\_ADC Register**

15	14	13	12	11	10	9	8
RESERVED				VPMID_ADC			
R-0h				R-0h			
7	6	5	4	3	2	1	0
VPMID_ADC						RESERVED	
R-0h						R-0h	

**Table 8-37. REG0x2E\_VPMID\_ADC Register Field Descriptions**

Bit	Field	Type	Reset	Notes	Description
15	RESERVED	R	0h		Reserved
14:2	VPMID_ADC	R	0h		VPMID ADC reading POR: 0mV (0h) Range: 0mV-18000mV (0h-11B6h) Clamped High Bit Step: 3.97mV
1:0	RESERVED	R	0h		Reserved

### 8.6.2.32 REG0x30\_VBAT\_ADC Register (Address = 30h) [Reset = 0000h]

REG0x30\_VBAT\_ADC is shown in [Figure 8-46](#) and described in [Table 8-38](#).

Return to the [Summary Table](#).

VBAT ADC

**Figure 8-46. REG0x30\_VBAT\_ADC Register**

15	14	13	12	11	10	9	8
RESERVED				VBAT_ADC			
R-0h				R-0h			
7	6	5	4	3	2	1	0
VBAT_ADC						RESERVED	
R-0h						R-0h	

**Table 8-38. REG0x30\_VBAT\_ADC Register Field Descriptions**

Bit	Field	Type	Reset	Notes	Description
15:13	RESERVED	R	0h		Reserved
12:1	VBAT_ADC	R	0h		VBAT ADC reading POR: 0mV (0h) Range: 0mV-5572mV (0h-AF0h) Clamped High Bit Step: 1.99mV
0	RESERVED	R	0h		Reserved

### 8.6.2.33 REG0x32\_VSYS\_ADC Register (Address = 32h) [Reset = 0000h]

REG0x32\_VSYS\_ADC is shown in [Figure 8-47](#) and described in [Table 8-39](#).

Return to the [Summary Table](#).

## VSYS ADC

**Figure 8-47. REG0x32\_VSYS\_ADC Register**

15	14	13	12	11	10	9	8
RESERVED				VSYS_ADC			
R-0h				R-0h			
7	6	5	4	3	2	1	0
VSYS_ADC							RESERVED
R-0h							R-0h

**Table 8-39. REG0x32\_VSYS\_ADC Register Field Descriptions**

Bit	Field	Type	Reset	Notes	Description
15:13	RESERVED	R	0h		Reserved
12:1	VSYS_ADC	R	0h		VSYS ADC reading POR: 0mV (0h) Range: 0mV-5572mV (0h-AF0h) Clamped High Bit Step: 1.99mV
0	RESERVED	R	0h		Reserved

**8.6.2.34 REG0x34\_TS\_ADC Register (Address = 34h) [Reset = 0000h]**

REG0x34\_TS\_ADC is shown in [Figure 8-48](#) and described in [Table 8-40](#).

Return to the [Summary Table](#).

## TS ADC

**Figure 8-48. REG0x34\_TS\_ADC Register**

15	14	13	12	11	10	9	8
RESERVED				TS_ADC			
R-0h				R-0h			
7	6	5	4	3	2	1	0
TS_ADC							
R-0h							

**Table 8-40. REG0x34\_TS\_ADC Register Field Descriptions**

Bit	Field	Type	Reset	Notes	Description
15:12	RESERVED	R	0h		Reserved
11:0	TS_ADC	R	0h	Reset by: Adapter Plug In	TS ADC reading as TS pin voltage in percentage of bias reference. Valid with TS pin bias reference active. POR: 0%(0h) Range: 0% - 98.3103% (0h-3FFh) Clamped High Bit Step: 0.0961%

### 8.6.2.35 REG0x36\_TDIE\_ADC Register (Address = 36h) [Reset = 0000h]

REG0x36\_TDIE\_ADC is shown in [Figure 8-49](#) and described in [Table 8-41](#).

Return to the [Summary Table](#).

TDIE ADC

**Figure 8-49. REG0x36\_TDIE\_ADC Register**

15	14	13	12	11	10	9	8
RESERVED				TDIE_ADC			
R-0h				R-0h			
7	6	5	4	3	2	1	0
TDIE_ADC							
R-0h							

**Table 8-41. REG0x36\_TDIE\_ADC Register Field Descriptions**

Bit	Field	Type	Reset	Notes	Description
15:12	RESERVED	R	0h		Reserved
11:0	TDIE_ADC	R	0h		TDIE ADC reading Reported in 2 's Complement. POR: 0°C(0h) Format: 2s Complement Range: -40°C - 140°C (FB0h-118h) Clamped Low Clamped High Bit Step: 0.5°C

### 8.6.2.36 REG0x38\_Part\_Information Register (Address = 38h) [Reset = 02h]

REG0x38\_Part\_Information is shown in [Figure 8-50](#) and described in [Table 8-42](#).

Return to the [Summary Table](#).

Part Information

**Figure 8-50. REG0x38\_Part\_Information Register**

7	6	5	4	3	2	1	0
RESERVED		PN			DEV_REV		
R-0h		R-0h			R-2h		

**Table 8-42. REG0x38\_Part\_Information Register Field Descriptions**

Bit	Field	Type	Reset	Notes	Description
7:6	RESERVED	R	0h		Reserved
5:3	PN	R	0h		Device Part number All the other options are reserved 3h = BQ25622E
2:0	DEV_REV	R	2h		Device Revision

## 9 Application and Implementation

### Note

Information in the following applications sections is not part of the TI component specification, and TI does not warrant its accuracy or completeness. TI's customers are responsible for determining suitability of components for their purposes, as well as validating and testing their design implementation to confirm system functionality.

### 9.1 Application Information

A typical application consists of the device configured as an I<sup>2</sup>C controlled power path management device and a single cell battery charger for Li-Ion and Li-polymer batteries used in a wide range of smartphone and other portable devices. It integrates an input reverse-block FET (RBFET, Q1), high-side switching FET (HSFET, Q2), low-side switching FET (LSFET, Q3), and battery FET (BATFET Q4) between the system and battery. The device also integrates a bootstrap diode for the high-side gate drive.

### 9.2 Typical Application

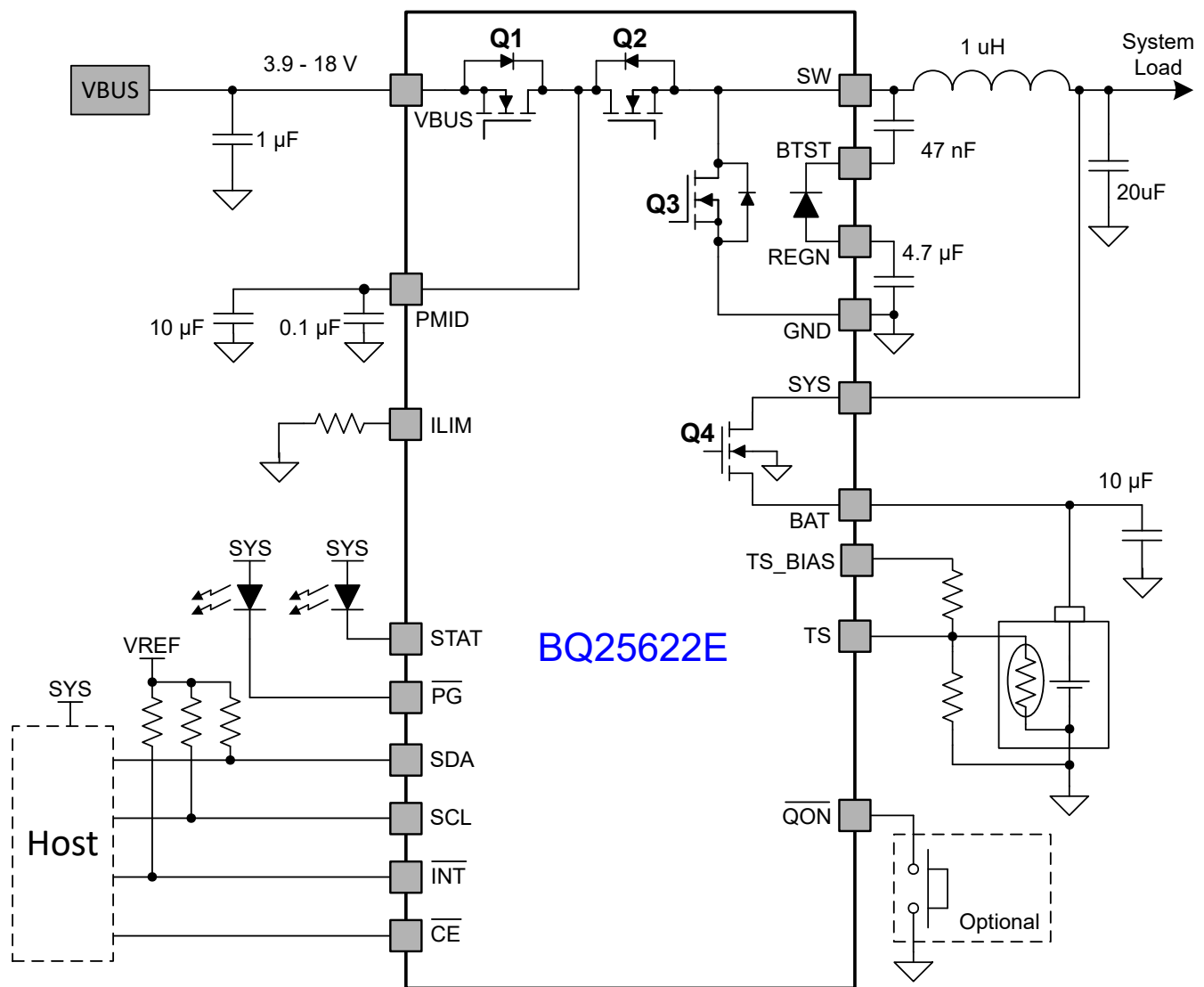

Figure 9-1. BQ25622E Application Diagram

## 9.2.1 Design Requirements

### 9.2.2 Detailed Design Procedure

#### 9.2.2.1 Inductor Selection

The 1.5-MHz switching frequency allows the use of small inductor and capacitor values to maintain an inductor saturation current higher than the charging current ( $I_{CHG}$ ) plus half the ripple current ( $I_{RIPPLE}$ ):

$$I_{SAT} \geq I_{CHG} + (1/2) I_{RIPPLE} \quad (3)$$

The inductor ripple current depends on the input voltage ( $V_{VBUS}$ ), the duty cycle ( $D = V_{BAT}/V_{VBUS}$ ), the switching frequency ( $f_S$ ) and the inductance (L).

$$I_{RIPPLE} = \frac{V_{IN} \times D \times (1 - D)}{f_S \times L} \quad (4)$$

The maximum inductor ripple current occurs when the duty cycle (D) is approximately 0.5. Usually inductor ripple is designed between 20% and 40% of the maximum charging current as a trade-off between inductor size and efficiency.

#### 9.2.2.2 Input Capacitor

Design input capacitance to provide enough ripple current rating to absorb input switching ripple current. The worst case RMS ripple current is half of the charging current when duty cycle is 0.5. If the converter does not operate at 50% duty cycle, then the worst case capacitor RMS current  $I_{CIN}$  occurs where the duty cycle is closest to 50% and can be estimated using [Equation 5](#).

$$I_{CIN} = I_{CHG} \times \sqrt{D \times (1 - D)} \quad (5)$$

Low ESR ceramic capacitor such as X7R or X5R is preferred for input decoupling capacitor and should be placed as close as possible to the drain of the high-side MOSFET (PMID) and source of the low-side MOSFET (GND). Voltage rating of the capacitor must be higher than normal input voltage level. A rating of 25-V or higher capacitor is preferred for 15 V input voltage. 10- $\mu$ F ceramic capacitor is suggested for typical of 3.5A charging current.

#### 9.2.2.3 Output Capacitor

Ensure that the output capacitance has enough ripple current rating to absorb the output switching ripple current. [Equation 6](#) shows the output capacitor RMS current  $I_{COUT}$  calculation.

$$I_{COUT} = \frac{I_{RIPPLE}}{2 \times \sqrt{3}} \approx 0.29 \times I_{RIPPLE} \quad (6)$$

The output capacitor voltage ripple can be calculated as follows:

$$\Delta V_{SYS} = \frac{V_{SYS}}{8 \times L \times C_{SYS} \times f_{SW}^2} \left( 1 - \frac{V_{SYS}}{V_{VBUS}} \right) \quad (7)$$

At certain input and output voltage and switching frequency, the voltage ripple can be reduced by increasing the output filter LC.

The charger device has internal loop compensation optimized for  $\geq 10$ - $\mu$ F ceramic output capacitor. The preferred ceramic capacitor is 10-V rating, X7R or X5R.

### 9.2.3 Application Curves

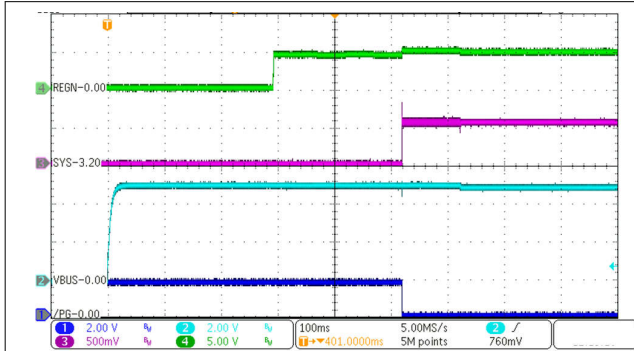

$V_{VBUS} = 5\text{ V}$                        $V_{BAT} = 3.2\text{ V}$   
 $I_{CHG} = 1\text{ A}$

**Figure 9-2. Power-Up with Charge Enabled**

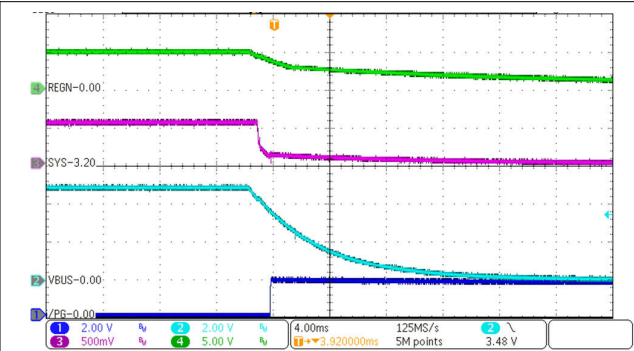

$V_{VBUS} = 5\text{ V}$                        $V_{BAT} = 3.2\text{ V}$   
 $I_{CHG} = 1\text{ A}$

**Figure 9-3. Power-Down**

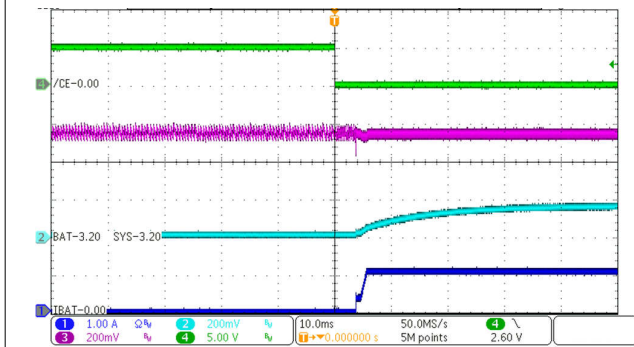

$V_{VBUS} = 5\text{ V}$                        $V_{BAT} = 3.2\text{ V}$   
 $I_{CHG} = 1\text{ A}$

**Figure 9-4. Charge Enable**

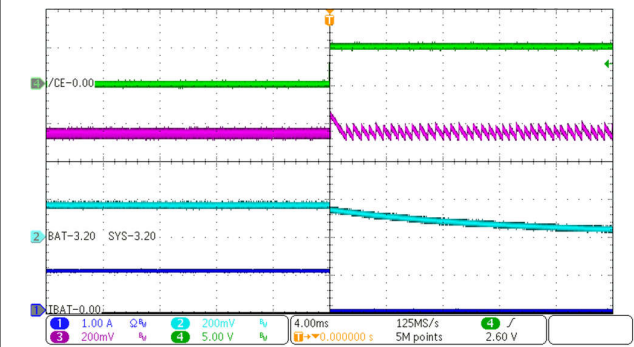

$V_{VBUS} = 5\text{ V}$                        $V_{BAT} = 3.2\text{ V}$   
 $I_{CHG} = 1\text{ A}$

**Figure 9-5. Charge Disable**

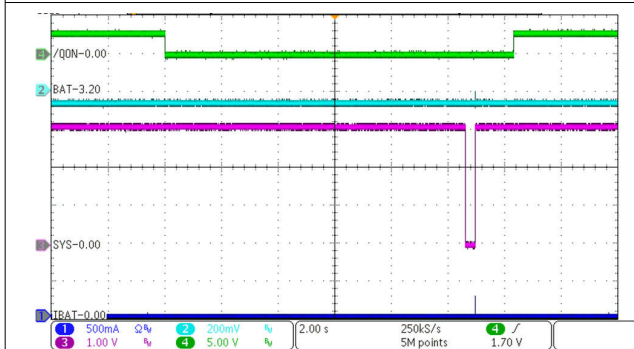

$V_{BAT} = 3.2\text{ V}$

**Figure 9-6. System Reset by QON without VBUS Present**

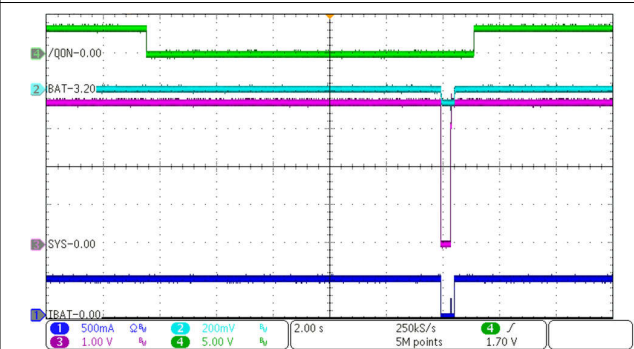

$V_{VBUS} = 5\text{ V}$                        $V_{BAT} = 3.2\text{ V}$   
 $I_{CHG} = 480\text{mA}$

**Figure 9-7. System Reset by QON with VBUS Present**

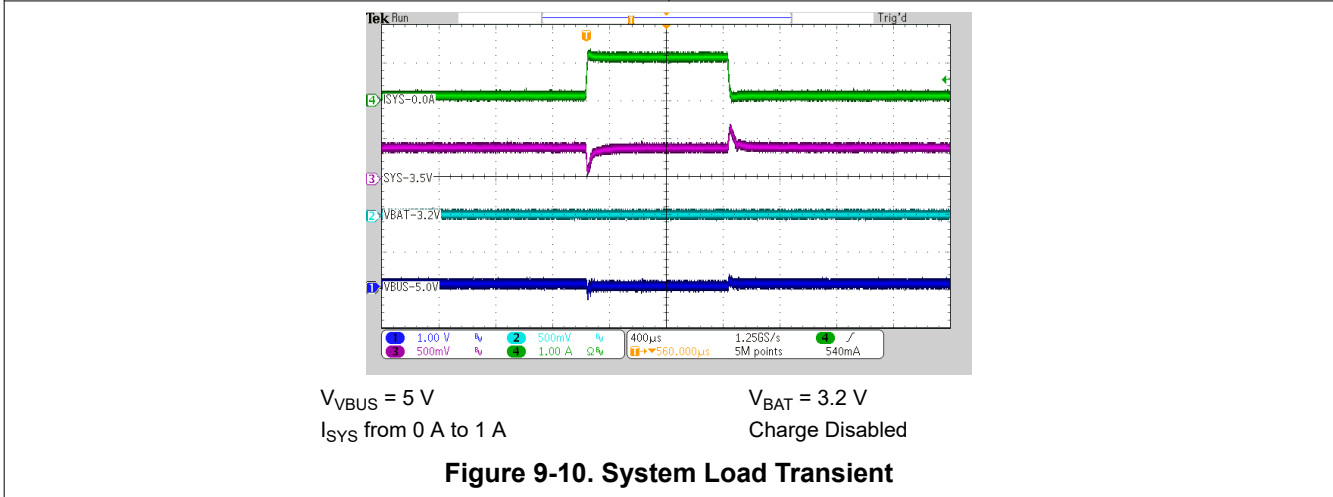
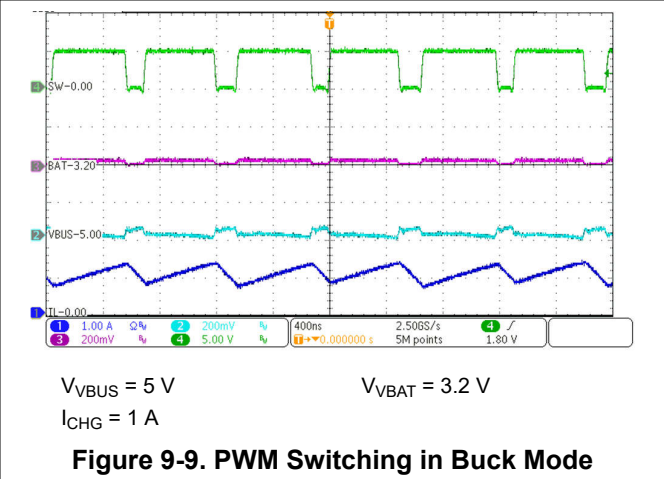
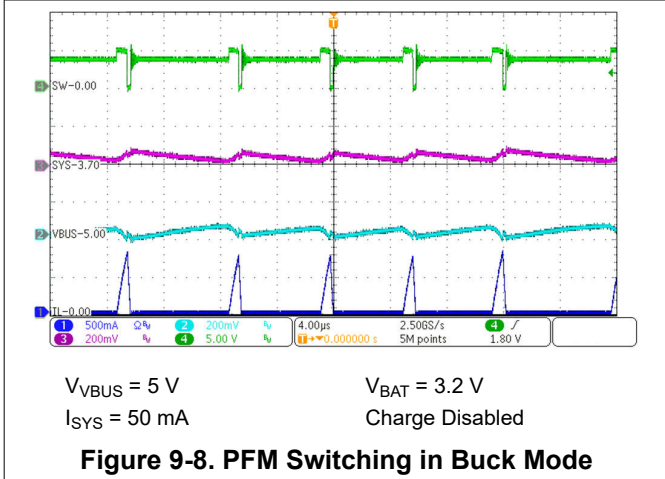

## 10 Power Supply Recommendations

In order to provide an output voltage on SYS, the device requires a power supply between 3.9 V and 18.0 V input with at least 100-mA current rating connected to VBUS or a single-cell Li-Ion battery with voltage >  $V_{BATUVLO}$  connected to BAT.

## 11 Layout

### 11.1 Layout Guidelines

The switching node rise and fall times should be minimized for lowest switching loss. Proper layout of the components to minimize high frequency current path loop (see [Figure 11-1](#)) is important to prevent electrical and magnetic field radiation and high frequency resonant problems. Follow this specific order carefully to achieve the proper layout.

1. For lowest switching noise during forward/charge mode, place the decoupling capacitor CPMID1 and then bulk capacitor CPMID2 positive terminals as close as possible to PMID pin. Place the capacitor ground terminal close to the GND pin using the shortest copper trace connection or GND plane on the same layer as the IC. See [Figure 11-2](#).
2. For lowest switching noise during reverse/OTG mode, place the CSYS1 and CSYS2 output capacitors' positive terminals near the SYS pin. The capacitors' ground terminals must be via'd down through multiple vias to an all ground internal layer that returns to IC GND pin through multiple vias under the IC. See [Figure 11-2](#).
3. Since REGN powers the internal gate drivers, place the CREGN capacitor positive terminal close to REGN pin to minimize switching noise. The capacitor's ground terminal must be via'd down through multiple vias to an all ground internal layer that returns to IC GND pin through multiple vias under the IC. See [Figure 11-2](#).
4. Place the CVBUS and CBAT capacitors positive terminals as close to the VBUS and BAT pins as possible. The capacitors' ground terminals must be via'd down through multiple vias to an all ground internal layer that returns to IC GND pin through multiple vias under the IC. See [Figure 11-2](#).
5. Place the inductor input pin near the positive terminal of the SYS pin capacitors. Due to the PMID capacitor placement requirements, the inductor's switching node terminal must be via'd down with multiple via's to a second internal layer with a wide trace that returns to the SW pin with multiple vias. See [Figure 11-3](#). Using multiple vias ensures that the via's additional resistance is negligible compared to the inductor's dc resistance and therefore does not impact efficiency. The vias additional series inductance is negligible compared to the inductor's inductance.
6. Place the BTST capacitor on the opposite side from the IC using vias to connect to the BTST pin and SW node. See [Figure 11-4](#).
7. A separate analog GND plane for non-power related resistors and capacitors is not required if those components are placed away from the power components traces and planes.
8. Ensure that the I2C SDA and SCL lines are routed away from the SW node.

Additionally, it is important that the PCB footprint and solder mask for the BQ25622E cover the entire length of each of the pins. GND, SW, PMID, SYS and BAT pins extend further into the package than the other pins. Using the entire length of these pins reduces parasitic resistance and increases thermal conductivity from the package into the board.

### 11.2 Layout Example

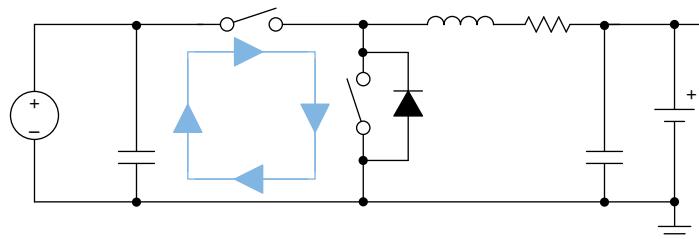

**Figure 11-1. High Frequency Current Path**

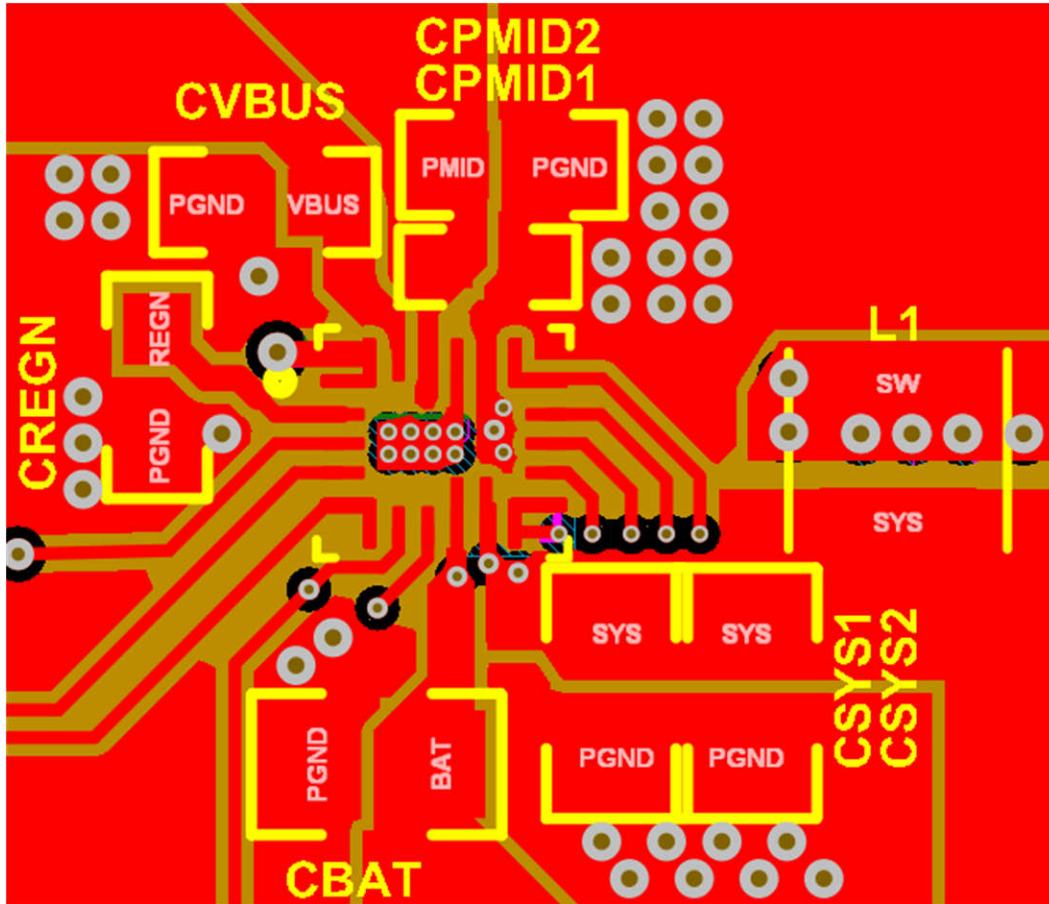

Figure 11-2. Layout Example: Top Layer (red) and All PGND Internal Layer 2 (brown)

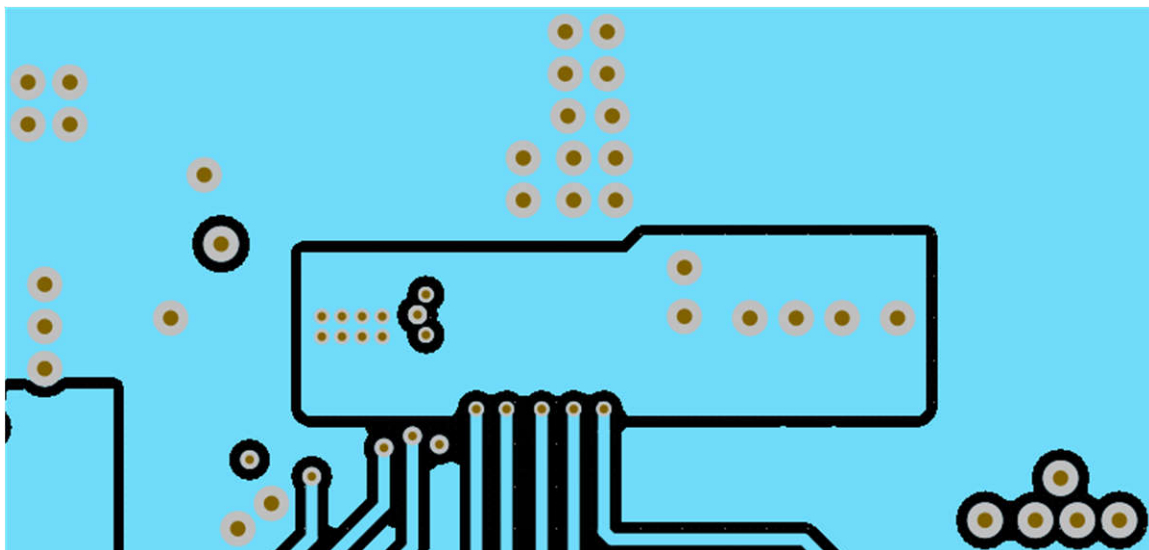

Figure 11-3. Layout Example: Inner Layer 3 (AGND pour; SW node pour; signal routing)

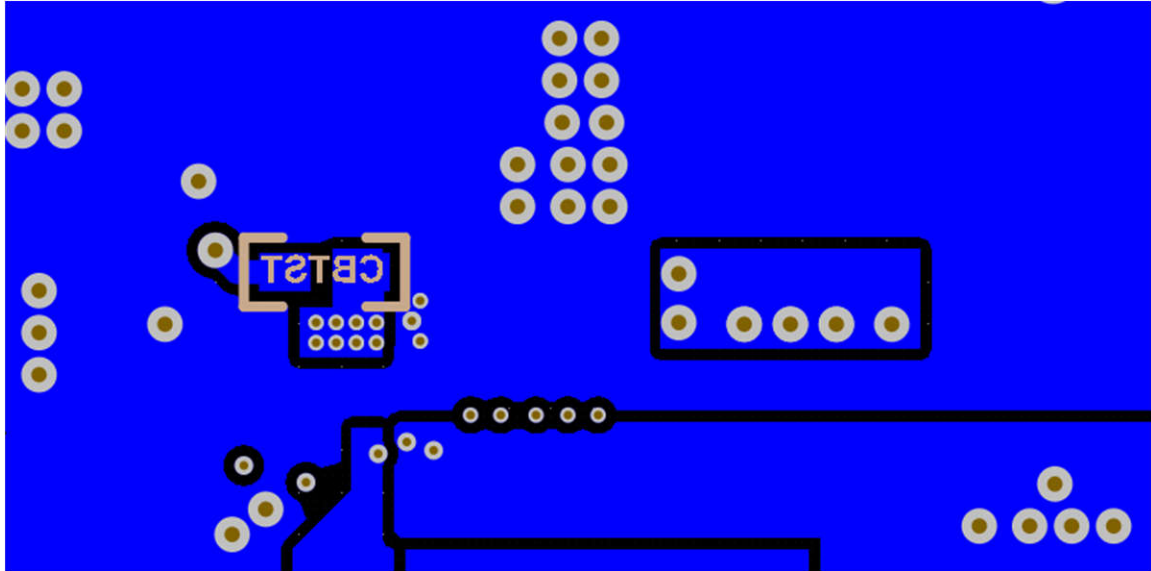

Figure 11-4. Layout Example: Bottom Layer X-Ray From Top (PGND pour; BTST capacitor; redundant SW, SYS and BAT pours)

## 12 Device and Documentation Support

### 12.1 Device Support

#### 12.1.1 Third-Party Products Disclaimer

TI'S PUBLICATION OF INFORMATION REGARDING THIRD-PARTY PRODUCTS OR SERVICES DOES NOT CONSTITUTE AN ENDORSEMENT REGARDING THE SUITABILITY OF SUCH PRODUCTS OR SERVICES OR A WARRANTY, REPRESENTATION OR ENDORSEMENT OF SUCH PRODUCTS OR SERVICES, EITHER ALONE OR IN COMBINATION WITH ANY TI PRODUCT OR SERVICE.

### 12.2 Documentation Support

#### 12.2.1 Related Documentation

For related documentation see the following:

- [BQ25601 and BQ25601D \(PWR877\) Evaluation Module User's Guide](#)

### 12.3 Receiving Notification of Documentation Updates

To receive notification of documentation updates, navigate to the device product folder on [ti.com](http://ti.com). Click on *Notifications* to register and receive a weekly digest of any product information that has changed. For change details, review the revision history included in any revised document.

### 12.4 Support Resources

[TI E2E™ support forums](#) are an engineer's go-to source for fast, verified answers and design help — straight from the experts. Search existing answers or ask your own question to get the quick design help you need.

Linked content is provided "AS IS" by the respective contributors. They do not constitute TI specifications and do not necessarily reflect TI's views; see TI's [Terms of Use](#).

### 12.5 Trademarks

TI E2E™ is a trademark of Texas Instruments.

All trademarks are the property of their respective owners.

### 12.6 Electrostatic Discharge Caution



This integrated circuit can be damaged by ESD. Texas Instruments recommends that all integrated circuits be handled with appropriate precautions. Failure to observe proper handling and installation procedures can cause damage.

ESD damage can range from subtle performance degradation to complete device failure. Precision integrated circuits may be more susceptible to damage because very small parametric changes could cause the device not to meet its published specifications.

### 12.7 Glossary

[TI Glossary](#) This glossary lists and explains terms, acronyms, and definitions.

## 13 Revision History

NOTE: Page numbers for previous revisions may differ from page numbers in the current version.

Changes from Revision B (February 2024) to Revision C (February 2025)	Page
• Removed 1.5A and 3A IBAT_PK Settings.....	8
• Changed T <sub>ADC_CONV</sub> Typical values.....	8
• Deleted "The converter is in constant-voltage regulation" from <a href="#">Section 8.3.5.3</a> .....	22
• Changed recommended values of RT1 and RT2 in <a href="#">Section 8.3.5.4.2</a> .....	23
• Updated description of ADC behavior in HIZ Mode in <a href="#">Section 8.3.6</a> .....	25
• Updated references to BATFET_DLY timing in <a href="#">Section 8.3.8.1</a> .....	27
• Changed 'VBUS_OVP_STAT' to 'VBUS_FAULT_STAT' in <a href="#">Section 8.3.9.2.1</a> .....	29
• Updated wait times related to I2C communication in <a href="#">Section 8.5.1</a> .....	32

• Removed IBAT_PK 1.5A and 3A Settings in Register Map.....	35
• Added Notes column to Register Map.....	35

---

**Changes from Revision A (January 2024) to Revision B (February 2024)**

**Page**

• Added IEC 62368-1 CB Certification.....	1
• Changed T <sub>TOP_OFF</sub> Typical and Maximum Limit.....	14
• Changed T <sub>SAFETY_TRKCHG</sub> Typical and Maximum Limit.....	14
• Changed T <sub>SAFETY_PRECHG</sub> Typical and Maximum Limit.....	14
• Changed T <sub>SAFETY</sub> Typical and Maximum Limit.....	14
• Changed T <sub>BATFET_DLY</sub> Typical Value.....	14
• Changed T <sub>SM_EXIT</sub> Typical and Maximum Limit.....	14
• Changed T <sub>QON_RST</sub> Typical and Maximum Limit.....	14
• Changed T <sub>BATFET_RST</sub> Typical Value.....	14
• Changed T <sub>LP_WDT</sub> Typical Value.....	14
• Changed T <sub>WDT</sub> Typical Value.....	14
• Added I <sup>2</sup> C timing requirements for fast mode and fast mode plus in <a href="#">Section 8.5.1</a> .....	32
• Changed TOPOFF_TMR values in Charge_Control_0 Register Description, PRECHG_TMR and CHG_TMR values in Charge_Timer_Control Register Description, and WATCHDOG values in Charger_Control_1 Register Description.....	35
• Updated behavior of IBAT_ADC in IBAT_ADC Register Description.....	35

---

**Changes from Revision \* (July 2023) to Revision A (January 2024)**

**Page**

• Changed t <sub>RST</sub> to t <sub>QON_RST</sub> in $\overline{QON}$ pin description.....	5
• Added $\overline{PG}$ pin description.....	5
• Added Maximum limit to V <sub>POORSRC</sub> .....	8
• Changed IBAT_ADC LSB from 2mA to 4mA.....	8
• Removed typical specs for t <sub>VBUS_OVP_PROP</sub> , T <sub>POORSRC_RETRY</sub> , t <sub>POORSRC_RESTART</sub> , t <sub>VBUS_PD</sub> , t <sub>TERM_DGL</sub> , t <sub>RECHG_DGL</sub> .....	14
• Clarified register conditions for T <sub>TOP_OFF</sub> specifications.....	14
• Added <a href="#">Figure 8-3</a> to TS Pin Thermistor Configuration.....	23
• Updated behavior of battery overcurrent protection in <a href="#">Section 8.3.9.1.2</a> .....	28
• Deleted invalid reference in <a href="#">Section 8.3.9.2.1</a> to improve clarity.....	29
• Deleted invalid reference in <a href="#">Section 8.3.9.2.2</a> to improve clarity.....	29
• Deleted invalid reference in <a href="#">Section 8.3.9.2.4</a> to improve clarity.....	29
• Deleted invalid reference in <a href="#">Section 8.3.9.2.5</a> to improve clarity.....	29
• Deleted invalid reference in <a href="#">Section 8.3.9.2.6</a> to improve clarity.....	29
• Added I <sup>2</sup> C address in <a href="#">Section 8.5.1</a> .....	32
• Changed bit 5 to Reserved, ICHG Reset from X to Dh, POR from 1Ah to Dh, Range from 2h-4Ch to 1h-26h, and Bit Step from 2h to 1h in Register Fields and Descriptions for REG0x02_Charge_Current_Limit register.....	35
• Changed bit 3 to Reserved, IPRECHG Reset from 0xA to 5h, POR from Ah to 5h, Range from 2h-3Eh to 1h-1Fh, and Bit Step from 2h to 1h in Register Fields and Descriptions for REG0x10_Pre-charge_Control register.....	35
• Changed bit 2 to Reserved, ITERM Reset from 0xC to 6h, POR from Ch to 6h, Range from 2h-7Ch to 1h-3Eh, and Bit Step from 2h to 1h in Register Fields and Descriptions for REG0x12_Termination_Control register.....	35
• Changed VBUS_ADC range maximum from 11B6h to 11B6h in REG0x2C_VBUS_ADC Register Field Descriptions.....	35

---

## 14 Mechanical, Packaging, and Orderable Information

The following pages include mechanical, packaging, and orderable information. This information is the most current data available for the designated devices. This data is subject to change without notice and revision of this document. For browser-based versions of this data sheet, refer to the left-hand navigation.

**PACKAGING INFORMATION**

Orderable part number	Status (1)	Material type (2)	Package   Pins	Package qty   Carrier	RoHS (3)	Lead finish/ Ball material (4)	MSL rating/ Peak reflow (5)	Op temp (°C)	Part marking (6)
<a href="#">BQ25622ERYKR</a>	Active	Production	WQFN-HR (RYK)   18	3000   LARGE T&R	Yes	SN	Level-2-260C-1 YEAR	-40 to 85	BQ622E
BQ25622ERYKR.A	Active	Production	WQFN-HR (RYK)   18	3000   LARGE T&R	Yes	SN	Level-2-260C-1 YEAR	-40 to 85	BQ622E

(1) **Status:** For more details on status, see our [product life cycle](#).

(2) **Material type:** When designated, preproduction parts are prototypes/experimental devices, and are not yet approved or released for full production. Testing and final process, including without limitation quality assurance, reliability performance testing, and/or process qualification, may not yet be complete, and this item is subject to further changes or possible discontinuation. If available for ordering, purchases will be subject to an additional waiver at checkout, and are intended for early internal evaluation purposes only. These items are sold without warranties of any kind.

(3) **RoHS values:** Yes, No, RoHS Exempt. See the [TI RoHS Statement](#) for additional information and value definition.

(4) **Lead finish/Ball material:** Parts may have multiple material finish options. Finish options are separated by a vertical ruled line. Lead finish/Ball material values may wrap to two lines if the finish value exceeds the maximum column width.

(5) **MSL rating/Peak reflow:** The moisture sensitivity level ratings and peak solder (reflow) temperatures. In the event that a part has multiple moisture sensitivity ratings, only the lowest level per JEDEC standards is shown. Refer to the shipping label for the actual reflow temperature that will be used to mount the part to the printed circuit board.

(6) **Part marking:** There may be an additional marking, which relates to the logo, the lot trace code information, or the environmental category of the part.

Multiple part markings will be inside parentheses. Only one part marking contained in parentheses and separated by a "~" will appear on a part. If a line is indented then it is a continuation of the previous line and the two combined represent the entire part marking for that device.

**Important Information and Disclaimer:** The information provided on this page represents TI's knowledge and belief as of the date that it is provided. TI bases its knowledge and belief on information provided by third parties, and makes no representation or warranty as to the accuracy of such information. Efforts are underway to better integrate information from third parties. TI has taken and continues to take reasonable steps to provide representative and accurate information but may not have conducted destructive testing or chemical analysis on incoming materials and chemicals. TI and TI suppliers consider certain information to be proprietary, and thus CAS numbers and other limited information may not be available for release.

In no event shall TI's liability arising out of such information exceed the total purchase price of the TI part(s) at issue in this document sold by TI to Customer on an annual basis.

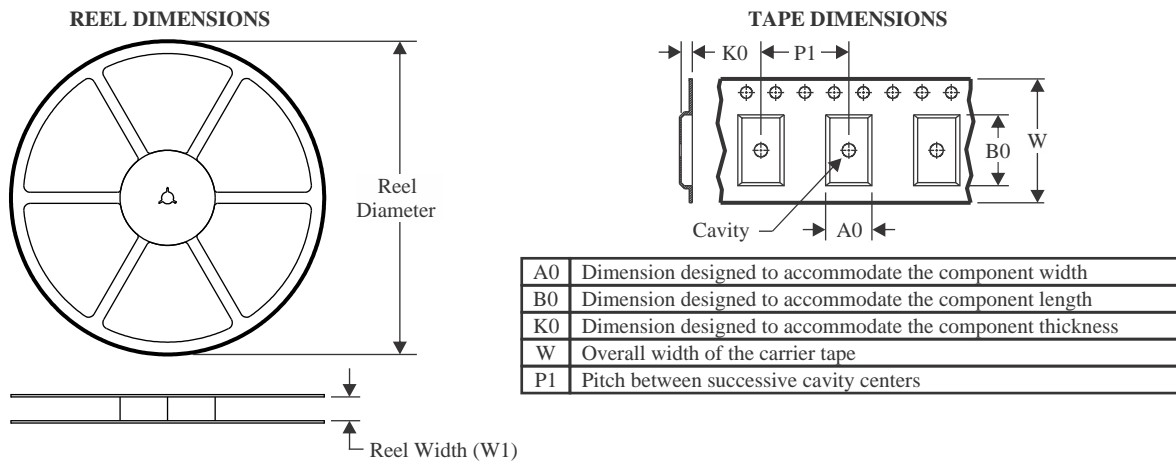
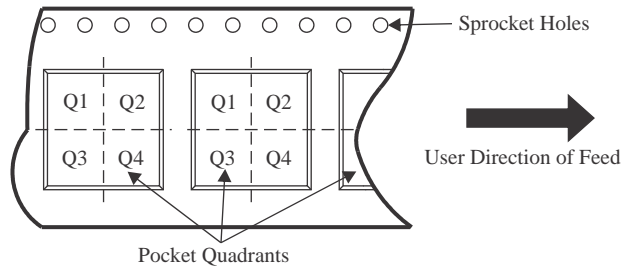
**TAPE AND REEL INFORMATION**

**QUADRANT ASSIGNMENTS FOR PIN 1 ORIENTATION IN TAPE**

\*All dimensions are nominal

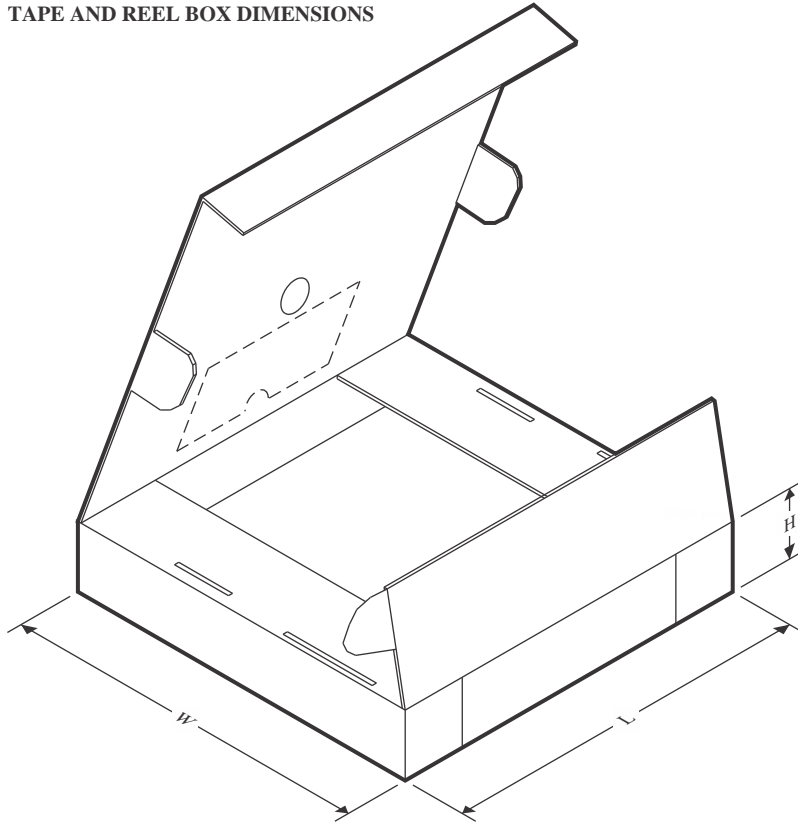
Device	Package Type	Package Drawing	Pins	SPQ	Reel Diameter (mm)	Reel Width W1 (mm)	A0 (mm)	B0 (mm)	K0 (mm)	P1 (mm)	W (mm)	Pin1 Quadrant
BQ25622ERYKR	WQFN-HR	RYK	18	3000	180.0	12.4	2.8	3.3	1.1	4.0	12.0	Q2

**TAPE AND REEL BOX DIMENSIONS**

\*All dimensions are nominal

Device	Package Type	Package Drawing	Pins	SPQ	Length (mm)	Width (mm)	Height (mm)
BQ25622ERYKR	WQFN-HR	RYK	18	3000	210.0	185.0	35.0

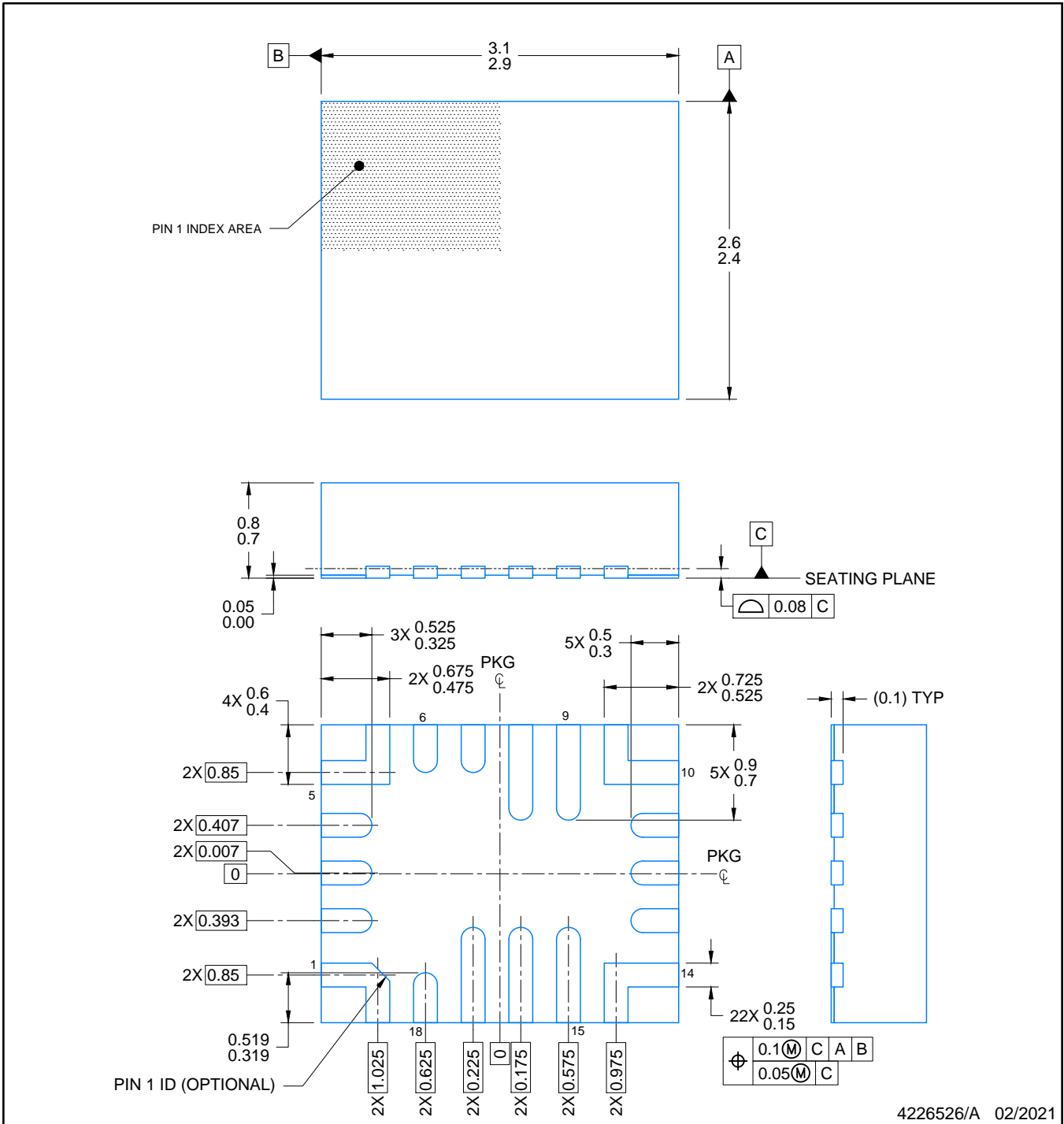

**NOTES:**

1. All linear dimensions are in millimeters. Any dimensions in parenthesis are for reference only. Dimensioning and tolerancing per ASME Y14.5M.
2. This drawing is subject to change without notice.

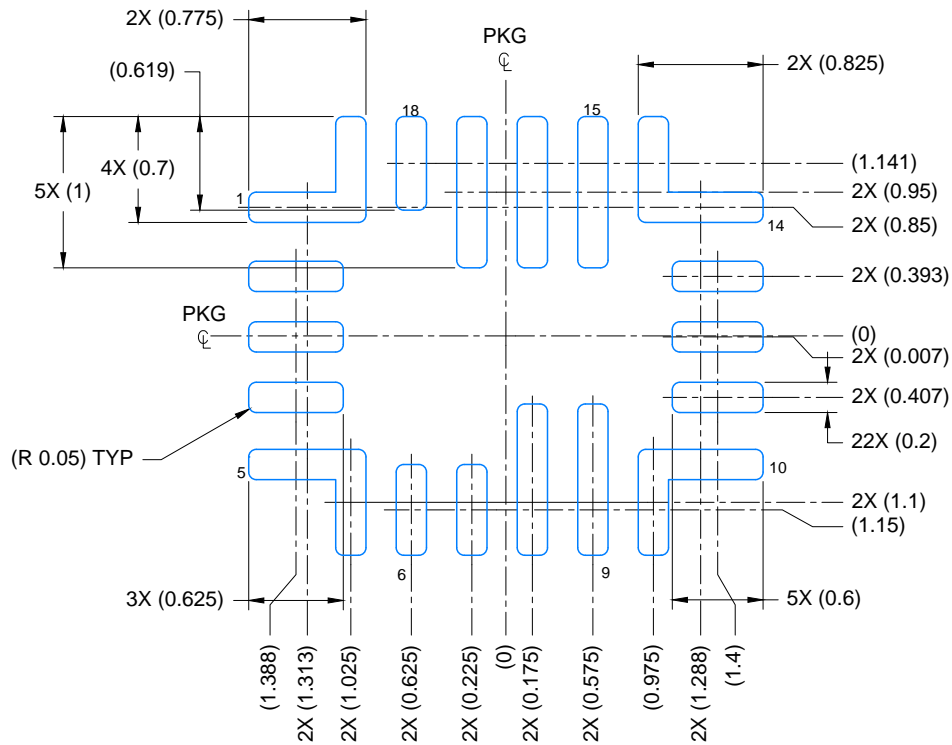

**LAND PATTERN EXAMPLE**  
EXPOSED METAL SHOWN  
SCALE: 20X

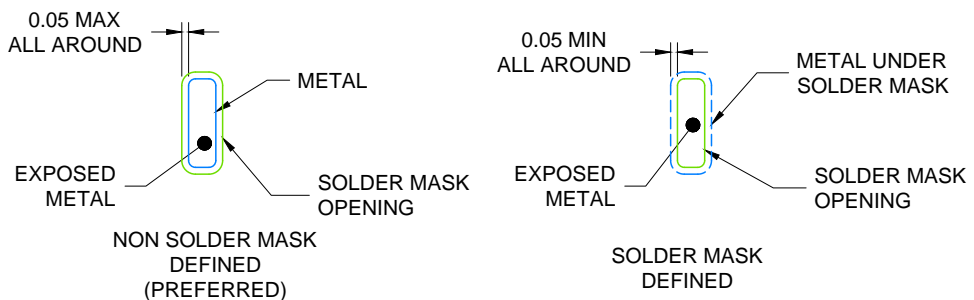

**SOLDER MASK DETAILS**

4226526/A 02/2021

NOTES: (continued)

3. For more information, see Texas Instruments literature number SLUA271 ([www.ti.com/lit/sluea271](http://www.ti.com/lit/sluea271)) .
4. Solder mask tolerances between and around signal pads can vary based on board fabrication site.

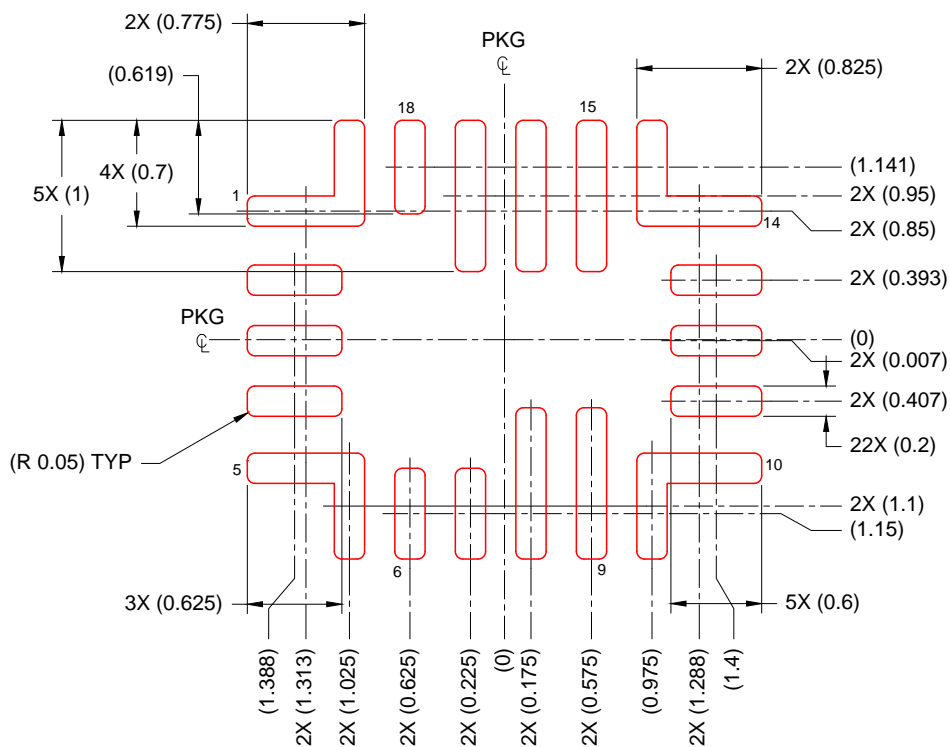

**SOLDER PASTE EXAMPLE**  
 BASED ON 0.100 mm THICK STENCIL  
 SCALE: 20X

4226526/A 02/2021

NOTES: (continued)

5. Laser cutting apertures with trapezoidal walls and rounded corners may offer better paste release. IPC-7525 may have alternate design recommendations.

## IMPORTANT NOTICE AND DISCLAIMER

TI PROVIDES TECHNICAL AND RELIABILITY DATA (INCLUDING DATASHEETS), DESIGN RESOURCES (INCLUDING REFERENCE DESIGNS), APPLICATION OR OTHER DESIGN ADVICE, WEB TOOLS, SAFETY INFORMATION, AND OTHER RESOURCES "AS IS" AND WITH ALL FAULTS, AND DISCLAIMS ALL WARRANTIES, EXPRESS AND IMPLIED, INCLUDING WITHOUT LIMITATION ANY IMPLIED WARRANTIES OF MERCHANTABILITY, FITNESS FOR A PARTICULAR PURPOSE OR NON-INFRINGEMENT OF THIRD PARTY INTELLECTUAL PROPERTY RIGHTS.

These resources are intended for skilled developers designing with TI products. You are solely responsible for (1) selecting the appropriate TI products for your application, (2) designing, validating and testing your application, and (3) ensuring your application meets applicable standards, and any other safety, security, regulatory or other requirements.

These resources are subject to change without notice. TI grants you permission to use these resources only for development of an application that uses the TI products described in the resource. Other reproduction and display of these resources is prohibited. No license is granted to any other TI intellectual property right or to any third party intellectual property right. TI disclaims responsibility for, and you fully indemnify TI and its representatives against any claims, damages, costs, losses, and liabilities arising out of your use of these resources.

TI's products are provided subject to [TI's Terms of Sale](#), [TI's General Quality Guidelines](#), or other applicable terms available either on [ti.com](#) or provided in conjunction with such TI products. TI's provision of these resources does not expand or otherwise alter TI's applicable warranties or warranty disclaimers for TI products. Unless TI explicitly designates a product as custom or customer-specified, TI products are standard, catalog, general purpose devices.

TI objects to and rejects any additional or different terms you may propose.

Copyright © 2025, Texas Instruments Incorporated

Last updated 10/2025

## Looking for pricing, stock, or lifecycle information?

Click below to explore more details on WIN SOURCE:

 [View BQ25622ERYKR on WIN SOURCE](#)

 [Texas Instruments](#) Information

## Optimize Your Supply Chain with WIN SOURCE Solutions

-  Global Sourcing Solution
-  Obsolete Management
-  Cost Control Management
-  Shortage Management
-  Alternative Solution
-  Excess Inventory Management