

## Precision Analog Microcontroller with RF Transceiver, ARM Cortex-M3

### FEATURES

- ▶ Analog input/output (I/O)
- ▶ 6-channel, 12-bit SAR ADC
  - ▶ Single-ended and differential inputs
  - ▶ Programmable data rate of up to 167 kSPS
  - ▶ On-chip voltage reference
  - ▶ Supply range: 2.2 V to 3.6 V
- ▶ Power consumption
  - ▶ 280 nA in shutdown mode, nonretained state
  - ▶ 1.9  $\mu$ A in hibernate mode, processor memory and transceiver memory retained, RF transceiver in sleep mode
  - ▶ 210  $\mu$ A/MHz Cortex-M3 dynamic current
  - ▶ 12.8 mA transceiver in receive mode, Cortex-M3 in hibernate mode
  - ▶ 9 mA to 32 mA transceiver in transmit mode, Cortex-M3 in hibernate mode
- ▶ RF transceiver
  - ▶ Frequency bands
    - ▶ 862 MHz to 928 MHz
    - ▶ 431 MHz to 464 MHz
  - ▶ Multiple configurations supported
  - ▶ Receiver sensitivity, bit error rate (BER)
    - ▶ -107.5 dBm at 38.4 kbps, 2FSK
  - ▶ Single-ended and differential power amplifier (PA)
  - ▶ Low external bill of materials (BOM)
- ▶ Microcontroller
  - ▶ 32-bit ARM Cortex-M3 processor
  - ▶ Serial wire download and debug
    - ▶ External watch crystal for wake-up timer
    - ▶ 16 MHz internal oscillator with 8-way, programmable divider
- ▶ Memory
  - ▶ 128 kB Flash/EE memory, 16 kB SRAM
  - ▶ 10,000-cycle Flash/EE endurance
  - ▶ 10-year Flash/EE retention
  - ▶ In-circuit download via serial wire and UART
- ▶ On-chip peripherals
  - ▶ UART, I<sup>2</sup>C, and SPI serial I/O
  - ▶ 28-pin GPIO port
  - ▶ 2 general-purpose, 16-bit timers
  - ▶ 32-bit wake-up timer
  - ▶ 16-bit watchdog timer
  - ▶ 8-channel pulse-width modulation (PWM)
- ▶ Package
  - ▶ 64-lead, 9 mm  $\times$  9 mm LFCSP
  - ▶ Temperature range: -40°C to +85°C
- ▶ Tools
  - ▶ Low cost development system
  - ▶ Third-party compiler and emulator tool support

### APPLICATIONS

- ▶ Battery-powered wireless sensors
- ▶ Medical telemetry systems
- ▶ Industrial and home automation
- ▶ Asset tracking
- ▶ Security systems (access systems)
- ▶ Health and fitness applications

### FUNCTIONAL BLOCK DIAGRAM

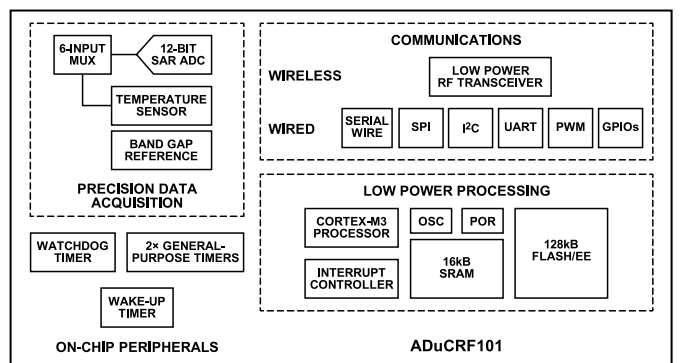

Figure 1.

Rev. B

DOCUMENT FEEDBACK

TECHNICAL SUPPORT

Information furnished by Analog Devices is believed to be accurate and reliable "as is". However, no responsibility is assumed by Analog Devices for its use, nor for any infringements of patents or other rights of third parties that may result from its use. Specifications subject to change without notice. No license is granted by implication or otherwise under any patent or patent rights of Analog Devices. Trademarks and registered trademarks are the property of their respective owners.

**TABLE OF CONTENTS**

Features.....	1	Absolute Maximum Ratings.....	12
Applications.....	1	Thermal Resistance.....	12
Functional Block Diagram.....	1	ESD Caution.....	12
General Description.....	3	Pin Configuration and Function Descriptions.....	13
Specifications.....	4	Typical Performance Characteristics.....	17
Electrical Specifications.....	4	Outline Dimensions.....	19
RF Link Specifications.....	6	Ordering Guide.....	19
Timing Specifications.....	8	Evaluation Boards.....	19

**REVISION HISTORY****10/2024—Rev. A to Rev. B**

Changed Master to Main and Slave to Subordinate (Throughout).....	1
---	---

## GENERAL DESCRIPTION

The ADuCRF101 is a fully integrated, data acquisition solution that is designed for low power, wireless applications. It features a 12-bit analog-to-digital converter (ADC), a low power ARM® Cortex®-M3 processor, a 862 MHz to 928 MHz and 431 MHz to 464 MHz RF transceiver, and Flash®/EE memory. The ADuCRF101 is packaged in a 9 mm × 9 mm LFCSP.

The data acquisition section consists of a 12-bit SAR ADC. The six inputs can be configured in single-ended or differential mode. When configured in single-ended mode, they can be used for ratiometric measurements on sensors that are powered, when required, from the internal low dropout regulator (LDO). An internal battery monitor channel and an on-chip temperature sensor are also available.

This wireless data acquisition system is designed to operate in battery-powered applications where low power is critical. The device can be configured in normal operating mode or different low power modes under direct program control. In flexi mode, any peripheral can wake up the device and operate it. In hibernate mode, the internal wake-up timer remains active. In shutdown mode, only an external interrupt can wake up the device.

The ADuCRF101 integrates a low power ARM Cortex-M3 processor. It is a 32-bit RISC machine, offering up to 1.25 DMIPS peak performance. The ARM Cortex-M3 processor also has a flexible 14-channel direct memory access (DMA) controller that supports communication peripherals, serial peripheral interface (SPI), UART,

and I<sup>2</sup>C. Also provided on chip are 128 kB of nonvolatile Flash/EE memory and 16 kB of SRAM.

A 16 MHz on-chip oscillator generates the system clock. This clock can be internally divided for the processor to operate at a lower frequency, thus saving power. A low power, internal 32 kHz oscillator is available and can be used to clock the four timers, as follows: two general-purpose timers, a wake-up timer, and a system watchdog timer.

A range of communication peripherals can be configured, as required, in a specific application. These peripherals include UART, I<sup>2</sup>C, SPI, GPIO ports, PWM, and RF transceivers.

The RF transceiver communicates in the 862 MHz to 928 MHz and 431 MHz to 464 MHz frequency bands using multiple configurations.

On-chip factory firmware supports in-circuit serial download via the UART, and nonintrusive emulation and program download are also supported via the serial wire interface. These features are incorporated into a low cost development system supporting this precision analog microcontroller family.

The ADuCRF101 operates from 2.2 V to 3.6 V and is specified over an industrial temperature range of -40°C to +85°C. It is available in a 64-lead LFCSP package.

## SPECIFICATIONS

## ELECTRICAL SPECIFICATIONS

AVDD = IOVDD = VDDBAT1 = VDDBAT2 = 2.2 V to 3.6 V, V<sub>REF</sub> = 1.25 V internal reference, f<sub>CORE</sub> = 16 MHz, T<sub>A</sub> = -40°C to +85°C, unless otherwise noted. Default ADC sampling frequency of 167 kSPS (eight acquisition clocks and ADC clock frequency of 4 MHz).

Table 1.

Parameter	Test Conditions/Comments	Min	Typ	Max	Unit
DC ACCURACY	Single-ended input mode; applies to all ADC input channels				
Resolution			12		Bits
Integral Nonlinearity	V <sub>REF</sub> = 1.25 V from internal reference		-2.5 to +1		LSB
	V <sub>REF</sub> = 1.8 V from LDO		-2.5 to +0.5		LSB
Differential Nonlinearity	Guaranteed no missing code at 167 kSPS		±1		LSB
DC Code Distribution					
Differential	ADC input shorted, V <sub>CM</sub> = 0.4 V		1		LSB
Ratiometric Measurement	Using two 10 kΩ resistors		5		LSB
CALIBRATED ENDPOINT ERRORS	Measured using the factory-set default values of the ADCOF and ADCGN registers <sup>1</sup>				
Offset Error			±1.6		LSB
Gain Error			±1		LSB
DYNAMIC PERFORMANCE	f <sub>IN</sub> = 1 kHz sine wave				
Signal-to-Noise Ratio (SNR)			68		dB
Signal-to-Noise + Distortion Ratio (SINAD)			66		dB
Total Harmonic Distortion (THD)			-69		dB
Spurious-Free Dynamic Range (SFDR)			70		dB
ANALOG INPUT					
Input Voltage Ranges <sup>2</sup>					
Single-Ended Input		0		V <sub>REF</sub>	V
Differential Input		0		V <sub>CM</sub> ± V <sub>REF</sub> /2	V
Leakage Current	Excluding VREF pin		100		nA
Input Capacitance	During ADC acquisition		20		pF
ON-CHIP VOLTAGE REFERENCE					
Output Voltage			1.25		V
Accuracy	Measured at T <sub>A</sub> = 25°C		±5		mV
Reference Temperature Coefficient			±40		ppm/°C
Power Supply Rejection Ratio (PSRR)			60		dB
Output Impedance			2		Ω
Internal V <sub>REF</sub> Power-On Time	0.47 μF external capacitor		5		ms
TEMPERATURE SENSOR <sup>2</sup>	Indicates die temperature				
Voltage Output at 25°C			435		mV
Voltage Temperature Coefficient			1.14		mV/°C
Thermal Impedance			35		°C/W
CURRENT CONSUMPTION					
Cortex-M3 in Shutdown Mode	RF transceiver in sleep mode, memory not retained		280		nA
Cortex-M3 in Hibernate Mode	Wake-up timer running from external 32 kHz crystal, 8 kB of SRAM retained (8 kB not retained)				
RF Transceiver in Sleep Mode					
Memory Retained			1.9		μA
Memory Not Retained			1.75		μA
RF Transceiver in Receive Mode			12.8		mA
RF Transceiver in Transmit Mode			9 to 32		mA

## SPECIFICATIONS

Table 1. (Continued)

Parameter	Test Conditions/Comments	Min	Typ	Max	Unit
Cortex-M3 in Active Mode Static Current	RF transceiver idle (PHY_ON state or PHY_OFF state) <sup>1</sup>		2.0		mA
Dynamic Current			210		µA/MHz
START-UP TIME <sup>2</sup>					
From Flexi Mode	FCLK is the Cortex-M3 clock or divided version of the 16 MHz oscillator		3 to 5		FCLK
From Hibernate Mode	From wake-up event to user code execution		13.4		µs
From Power-On and Shutdown Mode	From applying power/asserting active external interrupt to user code execution		55		ms
RF Link, Waking Up from Sleep Mode	Includes 310 µs for 26 MHz crystal startup (7 pF load capacitor at T <sub>A</sub> = 25°C)		562.8		µs
POWER SUPPLY REQUIREMENTS					
Power Supply Voltage Range <sup>2</sup>		2.2		3.6	V
POWER SUPPLY MONITOR					
Trip Point Voltage			2		V
WATCHDOG TIMER <sup>2</sup>					
Timeout Period	Programmable	0		512	sec
FLASH/EE MEMORY <sup>2</sup>					
Endurance <sup>3</sup>		10,000			Cycles
Data Retention <sup>4</sup>	T <sub>J</sub> = 85°C	10			Years
DIGITAL INPUTS					
Input Current (Leakage Current)	All digital inputs, excluding LFXTAL1 and XOSC26P V <sub>INH</sub> = IOVDD or V <sub>INH</sub> = 2.2 V, pull-up disabled; V <sub>INL</sub> = 0 V, pull-up disabled		10		nA
Input Capacitance	Excluding P2.4		10		pF
LOGIC INPUTS	All logic inputs, including LFXTAL1 but excluding XOSC26P				
Input Low Voltage, V <sub>INL</sub>				0.2 × IOVDD	V
Input High Voltage, V <sub>INH</sub>		0.7 × IOVDD			V
LOGIC OUTPUTS					
Output High Voltage, V <sub>OH</sub>	I <sub>SOURCE</sub> = 1 mA	IOVDD - 0.4			V
Output Low Voltage, V <sub>OL</sub>	I <sub>SINK</sub> = 1 mA			0.36	V
32.768 kHz CRYSTAL					
Input Current (Leakage Current)	32.768 kHz crystal, for use with timers V <sub>INH</sub> = IOVDD or V <sub>INH</sub> = 2.2 V, V <sub>INL</sub> = 0 V		50		nA
LFXTAL1 Input Capacitance			5		pF
LFXTAL2 Output Capacitance			5		pF
26 MHz CRYSTAL					
XOSC26P Input Capacitance			10		pF
XOSC26N Output Capacitance			10		pF
INTERNAL HIGH FREQUENCY (HF) OSCILLATOR	Processor clock by default		16		MHz
Tolerance			±3		%
INTERNAL LOW FREQUENCY (LF) OSCILLATOR			32.768		kHz
Tolerance			±20		%
MCU CLOCK DIVIDER <sup>2</sup>	Eight programmable core clock dividers	1		128	
EXTERNAL CLOCK INPUT <sup>2</sup>	External MCU clock range allowed				
Range		32.768		16,000	kHz

<sup>1</sup> For detailed information, see the [UG-231 User Guide](#).

## SPECIFICATIONS

<sup>2</sup> These values are not production tested; they are guaranteed by design and/or characterization data at production release.

<sup>3</sup> Endurance is qualified to 10,000 cycles as per JEDEC Standard No. 22-A117 and measured at -40°C, +25°C, and +85°C. Typical endurance at 25°C is 170,000 cycles.

<sup>4</sup> Retention lifetime equivalent at a junction temperature ( $T_J$ ) of 85°C as per JEDEC Standard No. 22-A117. Retention lifetime derates with junction temperature.

## RF LINK SPECIFICATIONS

Table 2.

Parameter	Test Conditions/Comments	Min	Typ	Max	Unit
FREQUENCY BANDS RANGE		862 431		928 464	MHz MHz
PHASE-LOCKED LOOP					
Channel Frequency Resolution			396.7		Hz
Phase Noise (In Band)	10 kHz offset, power amplifier (PA) output power = 10 dBm		-88		dBc/Hz
DATA RATE					
2FSK/GFSK		1		300	kbps
DIFFERENTIAL POWER AMPLIFIER (PA)					
Transmit Power <sup>1</sup>	Programmable		-17 to +10		dBm
Transmit Power Variation vs. Temperature	From -40°C to +85°C, RF frequency = 868 MHz		±1		dB
Transmit Power Flatness	From 902 MHz to 928 MHz and 863 MHz to 870 MHz		±1		dB
SINGLE-ENDED PA					
Transmit Power <sup>1</sup>	Programmable		-21 to 13		dBm
Transmit Power Variation vs. Temperature	From -40°C to +85°C, RF frequency = 868 MHz		±0.5		dB
Transmit Power Flatness	From 431 MHz to 464 MHz and 862 MHz to 928 MHz		±1		dB
HARMONICS	868 MHz, unfiltered conductive, PA output power = 10 dBm				
Single-Ended PA					
Second Harmonic			-29.8		dBc
Third Harmonic			-15.9		dBc
Fourth Harmonic			-24		dBc
Differential PA					
Second Harmonic			-33.6		dBc
Third Harmonic			-15.6		dBc
Fourth Harmonic			-36.7		dBc
OPTIMUM PA LOAD IMPEDANCE					
Single-Ended PA, Transmit Mode					
$f_{RF} = 915$ MHz			31.2 + j10.4		Ω
$f_{RF} = 868$ MHz			23.5 + j9.7		Ω
$f_{RF} = 433$ MHz			35.4 + j3.4		Ω
Single-Ended PA, Receive Mode					
$f_{RF} = 915$ MHz			7.3 - j126.3		Ω
$f_{RF} = 868$ MHz			6.9 - j134.2		Ω
Differential PA, Transmit Mode	Load impedance between RFIO_1P and RFIO_1N to ensure maximum output power				
$f_{RF} = 915$ MHz			38.7 + j20.6		Ω
$f_{RF} = 868$ MHz			42.2 + j20.1		Ω
$f_{RF} = 433$ MHz			55.6 + j54.9		Ω
2FSK/GFSK INPUT SENSITIVITY, BER	At BER = 10 <sup>-3</sup>				
1.0 kbps	Frequency deviation = 10 kHz, IF filter bandwidth = 100 kHz		-116		dBm
38.4 kbps	Frequency deviation = 20.0 kHz, IF filter bandwidth = 100 kHz		-107.5		dBm
300 kbps	Frequency deviation = 75 kHz, IF filter bandwidth = 300 kHz		-100.0		dBm

## SPECIFICATIONS

Table 2. (Continued)

Parameter	Test Conditions/Comments	Min	Typ	Max	Unit
2FSK/GFSK INPUT SENSITIVITY, PACKET ERROR RATE (PER)	At PER = 1%, packet length = 20 bytes, packet mode				
1.0 kbps	Frequency deviation = 10 kHz, IF filter bandwidth = 100 kHz		-114		dBm
38.4 kbps	Frequency deviation = 20.0 kHz, IF filter bandwidth = 100 kHz		-105.5		dBm
300 kbps	Frequency deviation = 75 kHz, IF filter bandwidth = 300 kHz		-96		dBm
ADJACENT CHANNEL REJECTION					
Continuous Wave (CW) Interferer	Wanted signal 3 dB above the input sensitivity level (BER = $10^{-3}$ ), CW interferer power level increased until BER = $10^{-3}$ , image calibrated				
±200 kHz Channel Spacing	IF bandwidth (BW) = 100 kHz, wanted signal: $f_{DEV} = 12.5$ kHz, DR = 50 kbps +200 kHz channel spacing/-200 kHz channel spacing		36/36		dB
±300 kHz Channel Spacing	IF BW = 100 kHz, wanted signal: $f_{DEV} = 25$ kHz, DR = 100 kbps +300 kHz channel spacing/-300 kHz channel spacing		39/39		dB
±600 kHz Channel Spacing	IF BW = 300 kHz, wanted signal: $f_{DEV} = 75$ kHz, DR = 300 kbps +600 kHz channel spacing/-600 kHz channel spacing		38/30		dB
Modulated Interferer	Wanted signal 3 dB above the input sensitivity level (BER = $10^{-3}$ ), modulated interferer with the same modulation as the wanted signal; interferer power level increased until BER = $10^{-3}$ , image calibrated				
±200 kHz Channel Spacing	IF BW = 100 kHz, wanted signal: $f_{DEV} = 12.5$ kHz, DR = 50 kbps +200 kHz channel spacing/-200 kHz channel spacing		34/34		dB
±300 kHz Channel Spacing	IF BW = 100 kHz, wanted signal: $f_{DEV} = 25$ kHz, DR = 100 kbps +300 kHz channel spacing/-300 kHz channel spacing		39/35		dB
±600 kHz Channel Spacing	IF BW = 300 kHz, wanted signal: $f_{DEV} = 75$ kHz, DR = 300 kbps +600 kHz channel spacing/-600 kHz channel spacing		35/16		dB
CO-CHANNEL REJECTION	Wanted signal 10 dB above the input sensitivity level (BER = $10^{-3}$ ), data rate = 38.4 kbps, frequency deviation = 20 kHz		-4		dB
BLOCKING, ETSI EN 300 220	Measurement procedure as per ETSI EN 300 220-1 V2.3.1; wanted signal 3 dB above the ETSI EN 300 220 reference sensitivity level of -99 dBm, IF bandwidth = 100 kHz, data rate = 38.4 kbps, unmodulated interferer				
±2 MHz			-29		dBm
±10 MHz			-20.5		dBm
WIDEBAND INTERFERENCE REJECTION	Swept from 10 MHz to 100 MHz either side of the RF frequency		75		dB
IMAGE CHANNEL ATTENUATION	Measured as image attenuation at the IF filter output, carrier wave interferer at 400 kHz below the channel frequency, 100 kHz IF filter bandwidth				
868 MHz	Uncalibrated <sup>2</sup> /calibrated		36/42		dB
RSSI					
Range at Input			-97 to -26		dBm
Linearity			±2		dB
Absolute Accuracy			±3		dB
LNA INPUT IMPEDANCE					
Receive Mode					
$f_{RF} = 915$ MHz			68.9 - j36.1		Ω
$f_{RF} = 868$ MHz			71.6 - j36.4		Ω
$f_{RF} = 433$ MHz			99.2 - j31.3		Ω
Transmit Mode					
$f_{RF} = 915$ MHz			8.6 + j21.1		Ω
$f_{RF} = 868$ MHz			8.6 + j20.4		Ω
$f_{RF} = 433$ MHz			8.2 + j11.4		Ω

## SPECIFICATIONS

Table 2. (Continued)

Parameter	Test Conditions/Comments	Min	Typ	Max	Unit
RX SPURIOUS EMISSIONS <sup>3</sup>					
Maximum < 1 GHz	At antenna input, unfiltered conductive		-66		dBm
Maximum > 1 GHz	At antenna input, unfiltered conductive		-51		dBm

<sup>1</sup> Measured as the maximum unmodulated power.

<sup>2</sup> Measured with Bits IMAGE\_REJECT\_CAL\_AMPLITUDE = 0x7 and Bits IMAGE\_REJECT\_CAL\_PHASE = 0x16. For more detailed information, see the [UG-231 User Guide](#).

<sup>3</sup> To achieve the relevant FCC/ETSI specifications, follow the matching and layout guideline information provided in the UG-231 User Guide.

## TIMING SPECIFICATIONS

I<sup>2</sup>C Timing

Capacitive load for each of the I<sup>2</sup>C bus lines, C<sub>b</sub> = 400 pF maximum as per the I<sup>2</sup>C bus specifications. I<sup>2</sup>C timing is guaranteed by design and not production tested.

I<sup>2</sup>C Timing in Fast Mode (400 KHz)

Table 3.

Parameter	Description	Min	Max	Unit
t <sub>L</sub>	Clock (I2CSCL) low pulse width	1300		ns
t <sub>H</sub>	Clock (I2CSCL) high pulse width	600		ns
t <sub>SHD</sub>	Start condition hold time	600		ns
t <sub>DSU</sub>	Data (I2CSDA) setup time	100		ns
t <sub>DHD</sub>	Data (I2CSDA) hold time	0		ns
t <sub>RSU</sub>	Setup time for repeated start	600		ns
t <sub>PSU</sub>	Stop condition setup time	600		ns
t <sub>BUF</sub>	Bus free time between a stop condition and a start condition	1.3		μs
t <sub>R</sub>	Rise time for both clock and data	20 + 0.1 C <sub>b</sub>	300	ns
t <sub>F</sub>	Fall time for both clock and data	20 + 0.1 C <sub>b</sub>	300	ns
t <sub>SUP</sub>	Pulse width of spike suppressed	0	50	ns

I<sup>2</sup>C Timing in Standard Mode (100 KHz)

Table 4.

Parameter	Description	Min	Max	Unit
t <sub>L</sub>	Clock (I2CSCL) low pulse width	4.7		μs
t <sub>H</sub>	Clock (I2CSCL) high pulse width	4.0		μs
t <sub>SHD</sub>	Start condition hold time	4.7		μs
t <sub>DSU</sub>	Data (I2CSDA) setup time	250		ns
t <sub>DHD</sub>	Data (I2CSDA) hold time	0		μs
t <sub>RSU</sub>	Setup time for repeated start	4.0		μs
t <sub>PSU</sub>	Stop condition setup time	4.0		μs
t <sub>BUF</sub>	Bus free time between a stop condition and a start condition	4.7		μs
t <sub>R</sub>	Rise time for both clock and data		1	μs
t <sub>F</sub>	Fall time for both clock and data		300	ns

SPECIFICATIONS

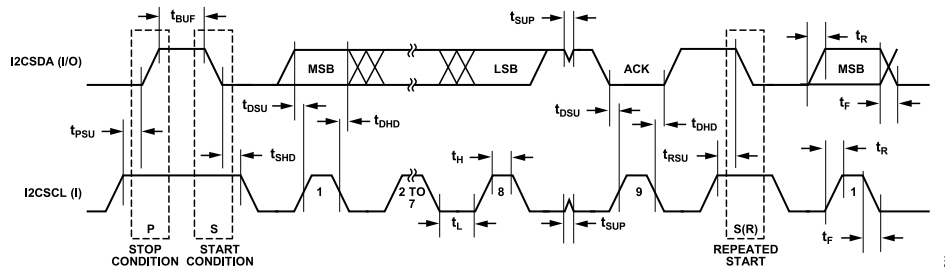

Figure 2. I<sup>2</sup>C Compatible Interface Timing

SPI Timing

SPI timing is guaranteed by design and not production tested.

SPI Main Mode Timing

Table 5.

Parameter	Description	Min	Typ	Max	Unit
$t_{SL}$	SCLK low pulse width <sup>1</sup>		$(SPIDIV^2 + 1) \times t_{UCLK}$		ns
$t_{SH}$	SCLK high pulse width <sup>1</sup>		$(SPIDIV^2 + 1) \times t_{UCLK}$		ns
$t_{DAV}$	Data output valid after SCLK edge		0	32.0	ns
$t_{DOSU}$	Data output setup before SCLK edge <sup>1</sup>	$(SPIDIV^2 + 1) \times t_{UCLK}$			ns
$t_{DSU}$	Data input setup time before SCLK edge	59.8			ns
$t_{DHD}$	Data input hold time after SCLK edge	16.0			ns
$t_{DF}$	Data output fall time		10.6	32.0	ns
$t_{DR}$	Data output rise time		10.6	32.0	ns
$t_{SR}$	SCLK rise time		10.6	32.0	ns
$t_{SF}$	SCLK fall time		10.6	32.0	ns

<sup>1</sup>  $t_{UCLK} = 62.5$  ns. It corresponds to the internal 16 MHz clock before the clock divider.

<sup>2</sup> For more information about SPIDIV, see the [UG-231 User Guide](#).

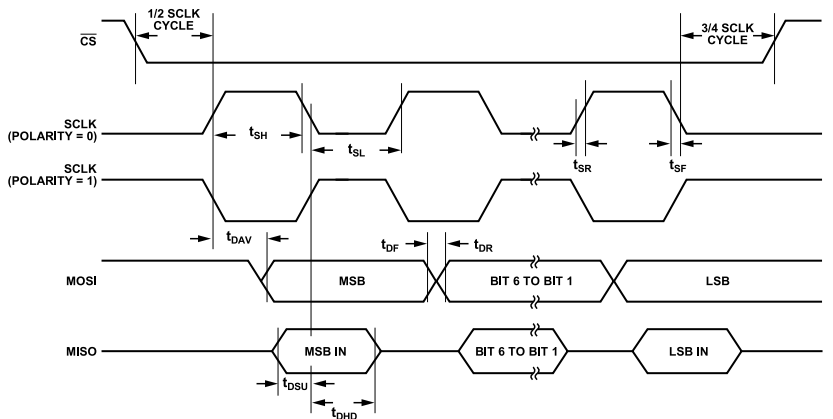

Figure 3. SPI Main Mode Timing (Phase Mode = 1)

SPECIFICATIONS

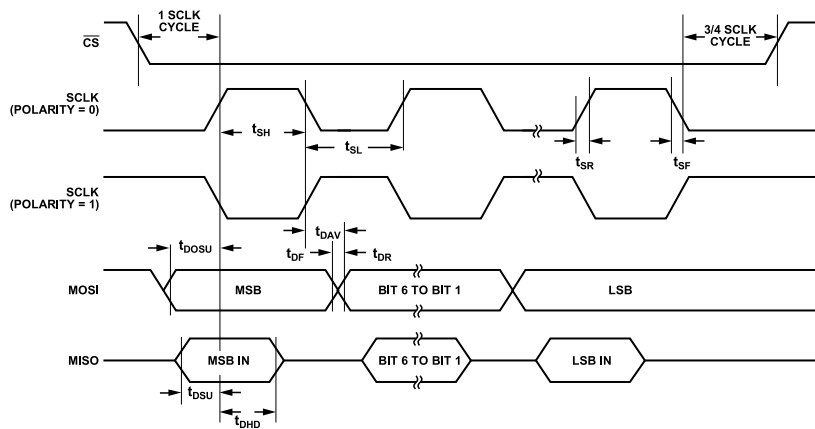

Figure 4. SPI Main Mode Timing (Phase Mode = 0)

SPI Subordinate Mode Timing

Table 6.

Parameter	Description	Min	Typ	Max	Unit
$t_{CS}$	$\overline{CS}$ to SCLK edge	12.9			ns
$t_{SL}$	SCLK low pulse width <sup>1</sup>		$(SPIDIV^2 + 1) \times t_{UCLK}$		ns
$t_{SH}$	SCLK high pulse width <sup>1</sup>	62.5	$(SPIDIV^2 + 1) \times t_{UCLK}$		ns
$t_{DAV}$	Data output valid after SCLK edge			47.4	ns
$t_{DSU}$	Data input setup time before SCLK edge	25.8			ns
$t_{DHD}$	Data input hold time after SCLK edge	12.9			ns
$t_{DF}$	Data output fall time		10.6	32.0	ns
$t_{DR}$	Data output rise time		10.6	32.0	ns
$t_{SR}$	SCLK rise time		10.6	32.0	ns
$t_{SF}$	SCLK fall time		10.6	32.0	ns
$t_{DOCS}$	Data output valid after $\overline{CS}$ edge			59.8	ns
$t_{SFS}$	$\overline{CS}$ high after SCLK edge	12.9			ns

<sup>1</sup>  $t_{UCLK} = 62.5$  ns. It corresponds to the internal 16 MHz clock before the clock divider.

<sup>2</sup> For more information about SPIDIV, see the [UG-231 User Guide](#).

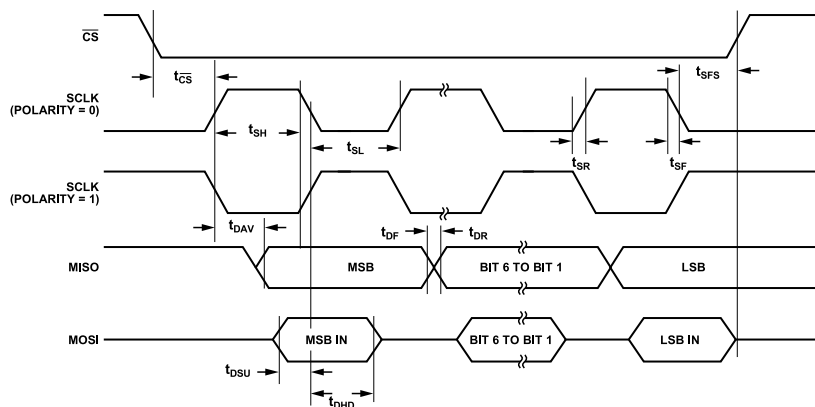

Figure 5. SPI Subordinate Mode Timing (Phase Mode = 1)

SPECIFICATIONS

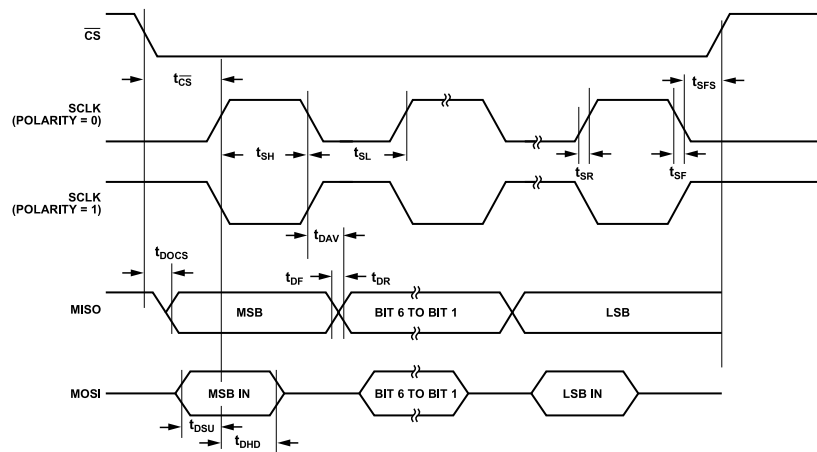

Figure 6. SPI Subordinate Mode Timing (Phase Mode = 0)

015

**ABSOLUTE MAXIMUM RATINGS**

$T_A = 25^\circ\text{C}$ , unless otherwise noted

**Table 7.**

Parameter	Rating
AVDD, IOVDD, VDDBAT1, and VDDBAT2 to GND	-0.3 V to +3.96 V
Digital Input Voltage to GND	-0.3 V to +3.96 V
Digital Output Voltage to GND	-0.3 V to +3.96 V
VREF to GND	-0.3 V to +3.96 V
Analog Inputs to GND	-0.3 V to +2.1 V
ESD (Human Body Model)	$\pm 2.5$ kV
Temperature	
Operating Temperature Range	$-40^\circ\text{C}$ to $+85^\circ\text{C}$
Storage Temperature Range	$-65^\circ\text{C}$ to $+150^\circ\text{C}$
Junction Temperature	$105^\circ\text{C}$
Peak Solder Reflow Temperature	
Pb-Free Assemblies (30 sec)	$260^\circ\text{C}$

Stresses at or above those listed under Absolute Maximum Ratings may cause permanent damage to the product. This is a stress rating only; functional operation of the product at these or any other conditions above those indicated in the operational section of this specification is not implied. Operation beyond the maximum operating conditions for extended periods may affect product reliability.

The exposed package paddle must be soldered to a metal pad on the printed circuit board (PCB) and connected to ground.

**THERMAL RESISTANCE**

$\theta_{JA}$  is specified for the worst-case conditions, that is, a device soldered in a circuit board for surface-mount packages.

**Table 8. Thermal Resistance**

Package Type	$\theta_{JA}$	Unit
64-Lead LFCSP_VQ	35	$^\circ\text{C/W}$

**ESD CAUTION**

**ESD (electrostatic discharge) sensitive device.** Charged devices and circuit boards can discharge without detection. Although this product features patented or proprietary protection circuitry, damage may occur on devices subjected to high energy ESD. Therefore, proper ESD precautions should be taken to avoid performance degradation or loss of functionality.

PIN CONFIGURATION AND FUNCTION DESCRIPTIONS

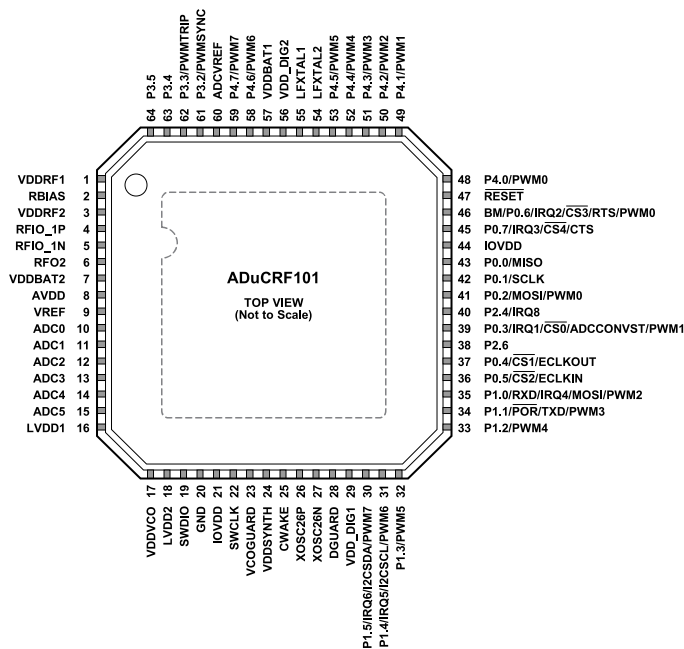

NOTES  
 1. THE EXPOSED PACKAGE PADDLE MUST BE SOLDERED TO A METAL PAD ON THE PCB AND CONNECTED TO GROUND.

Figure 7. Pin Configuration

Table 9. Pin Function Descriptions

Pin No.	Mnemonic	Description
1	VDDRF1	Voltage Regulator Output for RF Block. For regulator stability and noise rejection, place a 220 nF capacitor between this pin and ground.
2	RBIAS	External Bias Resistor. Use a 36 kΩ resistor with 2% tolerance.
3	VDDRF2	Voltage Regulator Output for RF Block. For regulator stability and noise rejection, place a 220 nF capacitor between this pin and ground.
4	RFIO_1P	LNA Positive Input in Receive Mode; Differential PA Positive Output in Transmit Mode.
5	RFIO_1N	LNA Negative Input in Receive Mode; Differential PA Negative Output in Transmit Mode.
6	RFO2	Single-Ended PA Output.
7	VDDBAT2	Battery Terminal <sup>1</sup> . Supply for the LDOs used in the RF section of the transceiver.
8	AVDD	Battery Terminal <sup>1</sup> . Supply for the analog circuits such as the ADC and ADC internal reference, POR, PSM, and LDOs.
9	VREF	Internal 1.25 V ADC Reference. Place a 0.47 μF capacitor between this pin and ground.
10	ADC0	ADC Input Channel 0. Input of DIFF0 pair in differential mode. <sup>2</sup>
11	ADC1	ADC Input Channel 1. Input of DIFF0 pair in differential mode. <sup>2</sup>
12	ADC2	ADC Input Channel 2. Input of DIFF1 pair in differential mode. <sup>2</sup>
13	ADC3	ADC Input Channel 3. Input of DIFF1 pair in differential mode. <sup>2</sup>
14	ADC4	ADC Input Channel 4. Input of DIFF2 pair in differential mode. <sup>2</sup>
15	ADC5	ADC Input Channel 5. Input of DIFF2 pair in differential mode. <sup>2</sup>
16	LVDD1	On-Chip LDO Decoupling Output. Connect a 0.47 μF capacitor to the 1.8 V output to ensure that the core operating voltage is stable. For correct operation, connect a 1 μF capacitor between this pin and LVDD2 (Pin 18).
17	VDDVCO	Voltage Regulator Output for Voltage Controlled Oscillator (VCO). For regulator stability and noise rejection, place a 220 nF capacitor between this pin and ground.
18	LVDD2	On-Chip LDO Decoupling Output. Connect a 0.47 μF capacitor to the 1.32 V output to ensure that the core operating voltage is stable. For correct operation, connect a 1 μF capacitor between this pin and LVDD1 (Pin 16).
19	SWDIO	Serial Wire Bidirectional Data.
20	GND	Ground. Connect this pin to the exposed pad.
21	IOVDD	General-Purpose I/O Supply <sup>1</sup> . Connect this pin to the battery terminal.

## PIN CONFIGURATION AND FUNCTION DESCRIPTIONS

Table 9. Pin Function Descriptions (Continued)

Pin No.	Mnemonic	Description
22	SWCLK	Serial Wire Debug Clock.
23	VCOGUARD	Guard, Screen for VCO. Connect this pin to VDDVCO.
24	VDDSYNTH	Voltage Regulator Output for Synthesizer. For regulator stability and noise rejection, place a 220 nF capacitor between this pin and ground.
25	CWAKE	External Capacitor for Wake-Up Control. Place a 150 nF capacitor between this pin and ground.
26	XOSC26P	Connect the 26 MHz reference crystal between this pin and XOSC26N (HFXTAL). <sup>3</sup>
27	XOSC26N	Connect the 26 MHz reference crystal between this pin and XOSC26P (HFXTAL).
28	DGUARD	Internal Guard, Screen for Digital Cells. Connect this pin to VDD_DIG1.
29	VDD_DIG1	Voltage Regulator Output for the Digital Section of the Transceiver. For regulator stability and noise rejection, place a 220 nF capacitor between this pin and ground.
30	P1.5/IRQ6/I2CSDA/PWM7	General-Purpose Input and Output Port 1.5 (P1.5). External Interrupt 6 (IRQ6). I <sup>2</sup> C Serial Data (I2CSDA). PWM Channel 7 (PWM7).
31	P1.4/IRQ5/I2CSCL/PWM6	General-Purpose Input and Output Port 1.4 (P1.4). External Interrupt 5 (IRQ5). I <sup>2</sup> C Serial Clock (I2CSCL). PWM Channel 6 (PWM6).
32	P1.3/PWM5	General-Purpose Input and Output Port 1.3 (P1.3). PWM Channel 5 (PWM5).
33	P1.2/PWM4	General-Purpose Input and Output Port 1.2 (P1.2). PWM Channel 4 (PWM4).
34	P1.1/ $\overline{POR}$ /TXD/PWM3	General-Purpose Input and Output Port 1.1 (P1.1). Power-On Reset Output ( $\overline{POR}$ ). UART TXD (TXD). PWM Channel 3 (PWM3).
35	P1.0/RXD/IRQ4/MOSI/PWM2	General-Purpose Input and Output Port 1.0 (P1.0). UART RXD (RXD). External Interrupt 4 (IRQ4). SPI1 Main Out, Subordinate In (MOSI). PWM Channel 2 (PWM2).
36	P0.5/ $\overline{CS2}$ /ECLKIN	General-Purpose Input and Output Port 0.5 (P0.5). SPI1 Chip Select 2 ( $\overline{CS2}$ ). External Clock Input (ECLKIN).
37	P0.4/ $\overline{CS1}$ /ECLKOUT	General-Purpose Input and Output Port 0.4 (P0.4). SPI1 Chip Select 1 ( $\overline{CS1}$ ). External Clock Output (ECLKOUT).
38	P2.6	General-Purpose Input and Output Port 2.6. Do not connect this pin. This pin is connected internally to the RF transceiver. It can be used for BER measurements.
39	P0.3/IRQ1/ $\overline{CS0}$ /ADCCONVST/PWM1	General-Purpose Input and Output Port 0.3 (P0.3). External Interrupt 1 (IRQ1). SPI1 Chip Select 0 ( $\overline{CS0}$ ). ADC Convert Start (ADCCONVST). PWM Channel 1 (PWM1).
40	P2.4/IRQ8	General-Purpose Input and Output Port 2.4 (P2.4). Do not connect this pin. This pin is connected internally to the RF transceiver and can be used for debug purposes to monitor RF transceiver interrupts. External Interrupt 8 (IRQ8).
41	P0.2/MOSI/PWM0	General-Purpose Input and Output Port 0.2 (P0.2). SPI1 Main Out, Subordinate In (MOSI).

## PIN CONFIGURATION AND FUNCTION DESCRIPTIONS

Table 9. Pin Function Descriptions (Continued)

Pin No.	Mnemonic	Description
42	P0.1/SCLK	PWM Channel 0 (PWM0). General-Purpose Input and Output Port 0.1 (P0.1). SPI1 Serial Clock (SCLK).
43	P0.0/MISO	General-Purpose Input and Output Port 0.0 (P0.0). SPI1 Main In, Subordinate Out (MISO).
44	IOVDD	General-Purpose I/O Supply <sup>1</sup> . Connect this pin to the battery terminal.
45	P0.7/IRQ3/ $\overline{CS4}$ /CTS	General-Purpose Input and Output Port 0.7 (P0.7). External Interrupt 3 (IRQ3). SPI1 Chip Select 4 ( $\overline{CS4}$ ). UART Handshake (CTS).
46	BM/P0.6/IRQ2/ $\overline{CS3}$ /RTS/PWM0	Boot Mode (BM). The ADuCRF101 enters serial download mode if P0.6 is low during, and for a short time after, an external reset event. It executes user code after any reset event or if P0.6 is high during an external reset event. General-Purpose Input and Output Port 0.6 (P0.6). External Interrupt 2 (IRQ2). SPI1 Chip Select 3 ( $\overline{CS3}$ ). UART Handshake (RTS). PWM Channel 0 (PWM0).
47	$\overline{RESET}$	Reset, Active Low. A low signal on this pin for 24 system clocks causes the device to reset.
48	P4.0/PWM0	General-Purpose Input and Output Port 4.0 (P4.0). PWM Channel 0 (PWM0).
49	P4.1/PWM1	General-Purpose Input and Output Port 4.1 (P4.1). PWM Channel 1 (PWM1).
50	P4.2/PWM2	General-Purpose Input and Output Port 4.2 (P4.2). PWM Channel 2 (PWM2).
51	P4.3/PWM3	General-Purpose Input and Output Port 4.3 (P4.3). PWM Channel 3 (PWM3).
52	P4.4/PWM4	General-Purpose Input and Output Port 4.4 (P4.4). PWM Channel 4 (PWM4).
53	P4.5/PWM5	General-Purpose Input and Output Port 4.5 (P4.5). PWM Channel 5 (PWM5).
54	LFXTAL2	32.768 kHz Watch Crystal Input for Wake-Up Timers.
55	LFXTAL1	32.768 kHz Watch Crystal Output for Wake-Up Timers.
56	VDD_DIG2	Voltage Regulator Output for the Digital Section of the Transceiver. For regulator stability and noise rejection, place a 220 nF capacitor between this pin and ground.
57	VDDBAT1	Battery Terminal <sup>1</sup> . Supply for the digital section of the transceiver and GPIOs.
58	P4.6/PWM6	General-Purpose Input and Output Port 4.6 (P4.6). PWM Channel 6 (PWM6).
59	P4.7/PWM7	General-Purpose Input and Output Port 4.7 (P4.7). PWM Channel 7 (PWM7).
60	ADCVREF	Transceiver ADC Reference Output. For adequate noise rejection, place a 220 nF capacitor between this pin and ground.
61	P3.2/PWMSYNC	General-Purpose Input and Output Port 3.2 (P3.2). PWM Synchronization (PWMSYNC).
62	P3.3/PWMTRIP	General-Purpose Input and Output Port 3.3 (P3.3). PWM Safety Cutoff (PWMTRIP).
63	P3.4	General-Purpose Input and Output Port 3.4.
64	P3.5	General-Purpose Input and Output Port 3.5.

**PIN CONFIGURATION AND FUNCTION DESCRIPTIONS****Table 9. Pin Function Descriptions (Continued)**

Pin No.	Mnemonic	Description
65	EP	Exposed Pad. The exposed package paddle must be soldered to a metal pad on the PCB and connected to ground.

<sup>1</sup> VDDBAT1, VDDBAT2, AVDD, and IOVDD must all be connected together.

<sup>2</sup> For detailed information about the DIFF0 to DIFF2 differential input pairs, see the [UG-231 User Guide](#).

<sup>3</sup> For detailed information about HFXTAL, a 26 MHz external crystal used to set the RF transceiver communication frequency, see the UG-231 User Guide.

TYPICAL PERFORMANCE CHARACTERISTICS

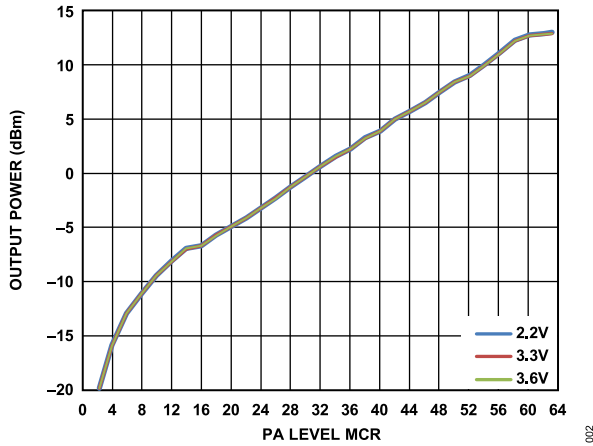

Figure 8. Single-Ended PA at 868 MHz, Output Power vs. PA Level MCR Setting and  $V_{DD}$

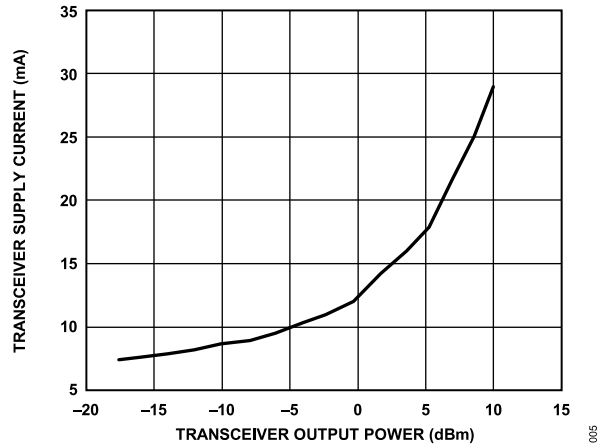

Figure 11. Differential PA at 868 MHz, Transceiver Supply Current vs. Transceiver Output Power;  $V_{DD} = 3.3 V$

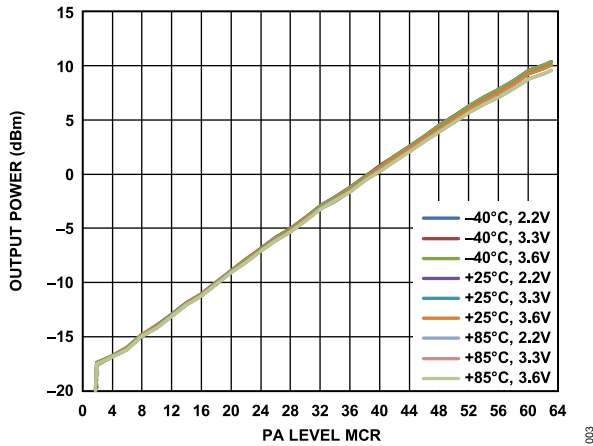

Figure 9. Differential PA at 868 MHz; Output Power vs. PA Level MCR Setting, Temperature, and  $V_{DD}$

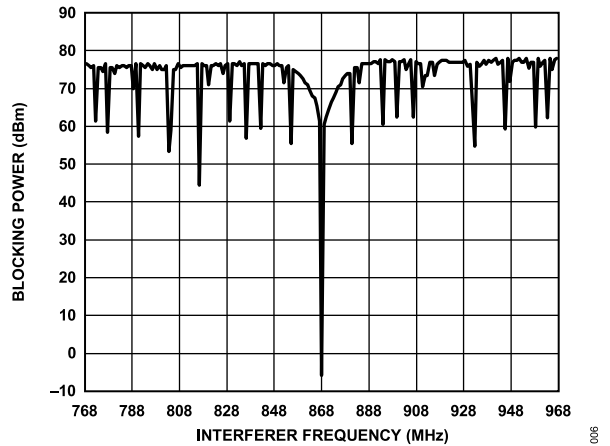

Figure 12. Typical Receiver Wideband Blocking at 868 MHz,  $V_{DD} = 3.3 V$ , Data Rate = 38.4 kbps, Frequency Deviation = 20 kHz, Measured as per ETSI EN 300 220

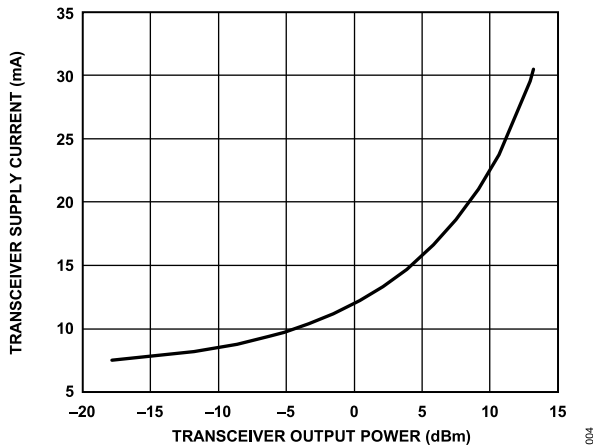

Figure 10. Single-Ended PA at 868 MHz, Transceiver Supply Current vs. Transceiver Output Power,  $V_{DD} = 3.3 V$

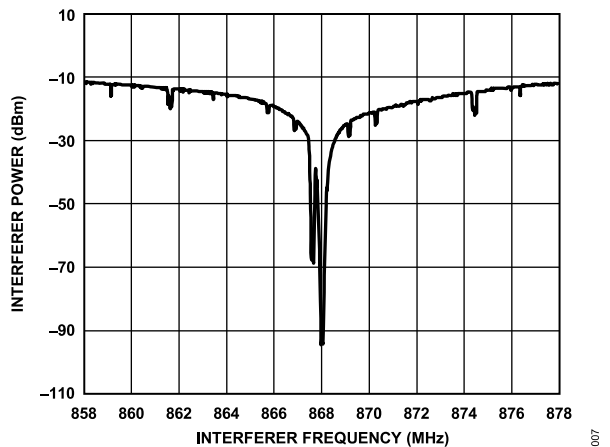

Figure 13. Typical Receiver Blocking at 868 MHz,  $V_{DD} = 3.3 V$ , Data Rate = 38.4 kbps, Frequency Deviation = 20 kHz, Measured as per ETSI EN 300 220

TYPICAL PERFORMANCE CHARACTERISTICS

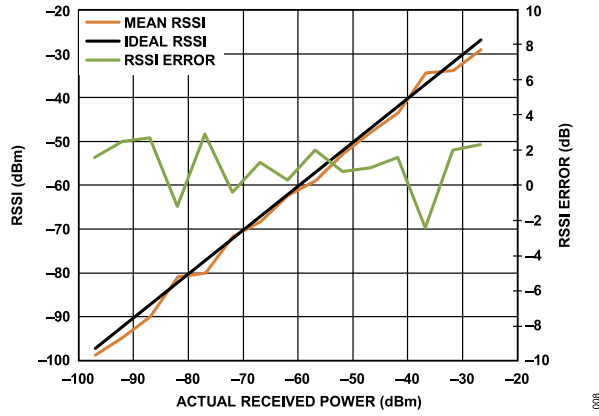

Figure 14. RSSI vs. Actual Received Power, 868 MHz, FSK, Data Rate = 38.4 kbps, Frequency Deviation = 20 kHz, IF Bandwidth = 100 kHz

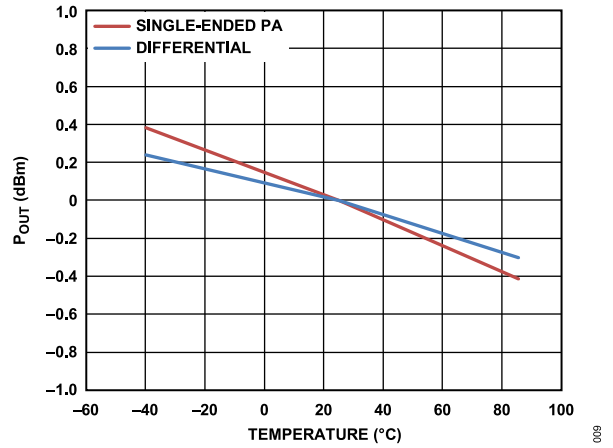

Figure 15. Single-Ended and Differential PA Output Power ( $P_{OUT}$ ) Deviation vs. Temperature; 868 MHz,  $V_{DD} = 3.3\text{ V}$

## OUTLINE DIMENSIONS

Package Drawing (Option)	Package Type	Package Description
CP-64-5	LFCSP	64-Lead Lead Frame Chip Scale Package

For the latest package outline information and land patterns (footprints), go to [Package Index](#).

## ORDERING GUIDE

Model <sup>1</sup>	Temperature Range	Package Description	Packing Quantity	Package Option
ADuCRF101BCPZ128	-40°C to +85°C	64-Lead Lead Frame Chip Scale Package (LFCSP)	Tray, 250	CP-64-5
ADuCRF101BCPZ128R7	-40°C to +85°C	64-Lead Lead Frame Chip Scale Package (LFCSP)	Reel, 750	CP-64-5
ADuCRF101BCPZ128RL	-40°C to +85°C	64-Lead Lead Frame Chip Scale Package (LFCSP)	Reel, 2500	CP-64-5

<sup>1</sup> Z = RoHS Compliant Part.

## EVALUATION BOARDS

Model <sup>1</sup>	Description
EV-ADuCRF101MK3Z	Evaluation Board 433 MHz Operation
EV-ADuCRF101MK1Z	Evaluation Board for 868 MHz/915 MHz Operation
EV-ADuCRF101QSP1Z	QuickStart Plus for 868 MHz/915 MHz Operation
EV-ADuCRF101QSP3Z	QuickStart Plus for 433 MHz Operation
EV-ADuCRF101QS1Z	QuickStart for 868 MHz/915 MHz Operation
EV-ADuCRF101QS3Z	QuickStart for 433 MHz Operation

<sup>1</sup> Z = RoHS Compliant Part.

I<sup>2</sup>C refers to a communications protocol originally developed by Philips Semiconductors (now NXP Semiconductors).

## Looking for pricing, stock, or lifecycle information?

Click below to explore more details on WIN SOURCE:

- ⊖ [View ADUCRF101BCPZ128RL on WIN SOURCE](#)
- ⊖ [Analog Devices Inc. Information](#)

## Optimize Your Supply Chain with WIN SOURCE Solutions

- ✓ Global Sourcing Solution
- ✓ Obsolete Management
- ✓ Cost Control Management
- ✓ Shortage Management
- ✓ Alternative Solution
- ✓ Excess Inventory Management