



Please note that Cypress is an Infineon Technologies Company.

The document following this cover page is marked as “Cypress” document as this is the company that originally developed the product. Please note that Infineon will continue to offer the product to new and existing customers as part of the Infineon product portfolio.

Continuity of document content

The fact that Infineon offers the following product as part of the Infineon product portfolio does not lead to any changes to this document. Future revisions will occur when appropriate, and any changes will be set out on the document history page.

Continuity of ordering part numbers

Infineon continues to support existing part numbers. Please continue to use the ordering part numbers listed in the datasheet for ordering.



PRELIMINARY

CYW43353

Single-Chip 5G MAC/Baseband/Radio with Integrated Bluetooth 4.1 for Automotive and Industrial Applications

General Description

The Cypress® CYW43353 single-chip device provides the highest level of integration for Automotive and Industrial connectivity systems with integrated single-stream IEEE 802.11ac MAC/baseband/radio, Bluetooth 4.1. In IEEE 802.11ac mode, the WLAN operation supports rates of MCS0–MCS9 (up to 256 QAM) in 20 MHz, 40 MHz, and 80 MHz channels for data rates up to 433.3 Mbps. In addition, all the rates specified in IEEE 802.11a/b/g/n are supported. Included on-chip are 2.4 GHz and 5 GHz transmit amplifiers, and receive low-noise amplifiers. Optional external PAs, LNAs, and antenna diversity are also supported.

The CYW43353 offers an SDIO v3.0 interface for high speed 802.11ac connectivity. The Bluetooth host controller is interfaced over a 4-wire high speed UART and includes PCM for audio.

The CYW43353 brings the latest mobile connectivity technology to automotive infotainment, telematics, rear seat entertainment, and industrial applications. Offering automotive Grade 3 (-40C to +85C) temperature performance, the CYW43353 is tested to AECQ100 environmental stress guidelines and manufactured in ISO9001 and TS16949 certified facilities.

The CYW43353 implements highly sophisticated enhanced collaborative coexistence hardware mechanisms and algorithms, which ensure that WLAN and Bluetooth collaboration is optimized for maximum performance. In addition, coexistence support for external radios (such as LTE cellular, GPS, and WiMAX) is provided via an external interface. As a result, enhanced overall quality for simultaneous voice, video, and data transmission is achieved.

Features

IEEE 802.11x Key Features

- IEEE 802.11ac compliant.
- Single-stream spatial multiplexing up to 433.3 Mbps data rate.
- Supports 20, 40, and 80 MHz channels with optional SGI (256 QAM modulation).
- Full IEEE 802.11a/b/g/n legacy compatibility with enhanced performance.
- Supports Rx space-time block coding (STBC)
- Supports IEEE 802.11ac/n beamforming.
- On-chip power amplifiers and low-noise amplifiers for both bands.
- Support for optional front-end modules (FEM) with external PAs and LNAs
- Shared Bluetooth and WLAN receive signal path eliminates the need for an external power splitter while maintaining excellent sensitivity for both Bluetooth and WLAN.
- Internal fractional nPLL allows support for a wide range of reference clock frequencies
- Supports IEEE 802.15.2 external coexistence interface to optimize bandwidth utilization with other co-located wireless technologies such as LTE, GPS, or WiMAX
- Supports standard SDIO v3.0 (including DDR50 mode at 50 MHz and SDR104 mode at 208 MHz, 4-bit and 1-bit), and gSPI (48 MHz) host interfaces.
- Backward compatible with SDIO v2.0 host interfaces.

- Integrated ARMCR4™ processor with tightly coupled memory for complete WLAN subsystem functionality, minimizing the need to wake up the applications processor for standard WLAN functions. This allows for further minimization of power consumption, while maintaining the ability to field upgrade with future features. On-chip memory includes 768 KB SRAM and 640 KB ROM.
- OneDriver™ software architecture for easy migration from existing embedded WLAN and Bluetooth devices as well as future devices.

Bluetooth Key Features

- Complies with Bluetooth Core Specification Version 4.1 for automotive and industrial applications with provisions for supporting future specifications.
- Bluetooth Class 1 or Class 2 transmitter operation.
- Supports extended synchronous connections (eSCO), for enhanced voice quality by allowing for retransmission of dropped packets.
- Adaptive frequency hopping (AFH) for reducing radio frequency interference.
- Interface support, host controller interface (HCI) using a high-speed UART interface and PCM for audio data.
- Supports multiple simultaneous Advanced Audio Distribution Profiles (A2DP) for stereo sound.
- Automatic frequency detection for standard crystal and TCXO values.

- Supports low energy host wake-up for long term system sleep capability.

General Features

- Supports battery voltage range from 3.0V to 4.8 supplies with internal switching regulator.
- Programmable dynamic power management
- OTP: 502 bytes of user-accessible memory
- Nine GPIOs
- Package options:
 - 145 ball WLBGA (4.87 mm × 5.413 mm, 0.4 mm pitch)

Security:

- WPA™ and WPA2™ (Personal) support for powerful encryption and authentication
- AES and TKIP in hardware for faster data encryption and IEEE 802.11i compatibility
- Reference WLAN subsystem provides Cisco® Compatible Extensions (CCX, CCX 2.0, CCX 3.0, CCX 4.0, CCX 5.0)
- Reference WLAN subsystem provides Wi-Fi Protected Setup (WPS)
- Worldwide regulatory support: Global products supported with worldwide homologated design.

Figure 1: Functional Block Diagram

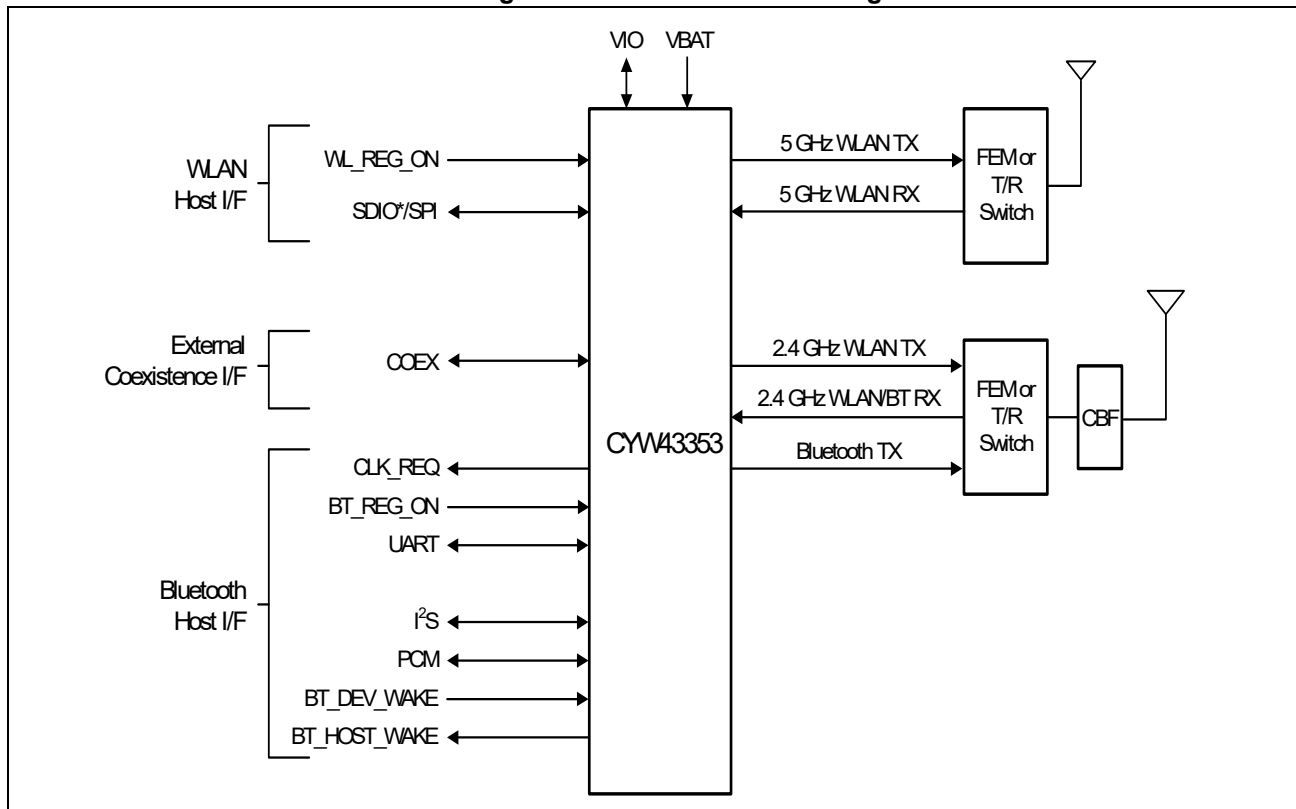

Contents

1. Overview	5	5.8 Fast Connection (Interlaced Page and Inquiry Scans)	25
1.1 Overview	5		
1.2 Features	7		
1.3 Standards Compliance	7		
1.4 Automotive and Industrial Usage Model	8		
2. Power Supplies and Power Management	9	6. Microprocessor and Memory Unit for Bluetooth	26
2.1 Power Supply Topology	9	6.1 RAM, ROM, and Patch Memory	26
2.2 PMU Features	9	6.2 Reset	26
2.3 WLAN Power Management	11	7. Bluetooth Peripheral Transport Unit.....	27
2.4 PMU Sequencing	11	7.1 PCM Interface	27
2.5 Power-Off Shutdown	12	7.1.1 Slot Mapping	27
2.6 Power-Up/Power-Down/Reset Circuits	12	7.1.2 Frame Synchronization	27
		7.1.3 Data Formatting	27
		7.1.4 Wideband Speech Support	27
		7.1.5 Multiplexed Bluetooth Over PCM	27
		7.1.6 PCM Interface Timing	29
3. Frequency References	13	7.2 UART Interface	33
3.1 Crystal Interface and Clock Generation	13	7.3 I ² S Interface	35
3.2 External Frequency Reference	14	7.3.1 I ² S Timing	35
3.3 Frequency Selection	15		
3.4 External 32.768 kHz Low-Power Oscillator	16	8. WLAN Global Functions.....	38
4. Bluetooth Subsystem Overview	17	8.1 WLAN CPU and Memory Subsystem	38
4.1 Features	17	8.2 One-Time Programmable Memory	38
4.2 Bluetooth Radio	18	8.3 GPIO Interface	38
4.2.1 Transmit	18	8.4 External Coexistence Interface	39
4.2.2 Digital Modulator	18	8.5 UART Interface	39
4.2.3 Digital Demodulator and Bit Synchronizer	18	8.6 JTAG Interface	39
4.2.4 Power Amplifier	18	9. WLAN Host Interfaces	40
4.2.5 Receiver	18	9.1 SDIO v3.0	40
4.2.6 Digital Demodulator and Bit Synchronizer	18	9.1.1 SDIO Pins	40
4.2.7 Receiver Signal Strength Indicator	19	9.2 Generic SPI Mode	41
4.2.8 Local Oscillator Generation	19	9.2.1 SPI Protocol	42
4.2.9 Calibration	19	9.2.2 gSPI Host-Device Handshake	46
		9.2.3 Boot-Up Sequence	46
5. Bluetooth Baseband Core	20	10. Wireless LAN MAC and PHY.....	49
5.1 Bluetooth 4.1 Features	20	10.1 IEEE 802.11ac MAC	49
5.2 Bluetooth Low Energy	20	10.1.1 PSM	50
5.3 Link Control Layer	21	10.1.2 WEP	50
5.4 Test Mode Support	21	10.1.3 TXE	50
5.5 Bluetooth Power Management Unit	22	10.1.4 RXE	50
5.5.1 RF Power Management	22	10.1.5 IFS	51
5.5.2 Host Controller Power Management	22	10.1.6 TSF	51
5.5.3 BBC Power Management	23	10.1.7 NAV	51
5.5.4 Wideband Speech	24	10.2 IEEE 802.11ac PHY	51
5.5.5 Packet Loss Concealment	24		
5.5.6 Audio Rate-Matching Algorithms	25	11. WLAN Radio Subsystem	53
5.5.7 Codec Encoding	25	11.1 Receiver Path	53
5.5.8 Multiple Simultaneous A2DP Audio Streams	25	11.2 Transmit Path	53
5.6 Adaptive Frequency Hopping	25	11.3 Calibration	53
5.7 Advanced Bluetooth/WLAN Coexistence	25		

12. Pinout and Signal Descriptions	55	16.5 LNLDO	90
12.1 Ball Maps	55	17. System Power Consumption	91
12.2 Signal Descriptions	56	17.1 WLAN Current Consumption	91
12.3 WLAN GPIO Signals and Strapping Options	61	17.2 Bluetooth Current Consumption	93
12.3.1 Multiplexed Bluetooth GPIO Signals	62	18. Interface Timing and AC Characteristics	94
12.4 GPIO/SDIO Alternative Signal Functions	64	18.1 SDIO/gSPI Timing	94
12.5 I/O States	65	18.1.1 SDIO Default Mode Timing	94
13. DC Characteristics	68	18.1.2 SDIO High-Speed Mode Timing	95
13.1 Absolute Maximum Ratings	68	18.1.3 SDIO Bus Timing Specifications in SDR	
13.2 Environmental Ratings	68	Modes	96
13.3 Electrostatic Discharge Specifications	69	18.1.4 SDIO Bus Timing Specifications in DDR50	
13.4 Recommended Operating Conditions and DC		Mode	99
Characteristics	69	18.1.5 gSPI Signal Timing	102
14. Bluetooth RF Specifications	71	18.2 JTAG Timing	102
15. WLAN RF Specifications	77	19. Power-Up Sequence and Timing	103
15.1 Introduction	77	19.1 Sequencing of Reset and Regulator Control	
15.2 2.4 GHz Band General RF Specifications	77	Signals	103
15.3 WLAN 2.4 GHz Receiver Performance		19.1.1 Description of Control Signals	103
Specifications	78	19.1.2 Control Signal Timing Diagrams	103
15.4 WLAN 2.4 GHz Transmitter Performance		20. Package Information	106
Specifications	81	20.1 Package Thermal Characteristics	106
15.5 WLAN 5 GHz Receiver Performance		20.2 Junction Temperature Estimation and PSI_{JT}	
Specifications	82	Versus $THETA_{JC}$	106
15.6 WLAN 5 GHz Transmitter Performance		20.3 Environmental Characteristics	106
Specifications	85	21. Mechanical Information	107
15.7 General Spurious Emissions Specifications	86	22. Ordering Information	109
16. Internal Regulator Electrical Specifications. 86		23. Additional Information	109
16.1 Core Buck Switching Regulator	86	23.1 Acronyms and Abbreviations	109
16.2 3.3V LDO (LDO3P3)	87	23.2 References	109
16.3 2.5V LDO (BTLDO2P5)	88	23.3 IoT Resources	109
16.4 CLDO	89	Document History Page	110
		Sales, Solutions, and Legal Information	112



PRELIMINARY

1. Overview

1.1 Overview

The Cypress CYW43353 single-chip device provides the highest level of integration for automotive and industrial wireless connectivity systems with support for IEEE 802.11a/b/g/n/ac MAC/baseband/radio, and Bluetooth 4.1 + enhanced data rate (EDR).

It provides a small form-factor solution with minimal external components to drive down cost for mass volumes and allows for platform flexibility.

The following figure shows the interconnect of all the major physical blocks in the CYW43353 and their associated external interfaces, which are detailed in the following sections.

Figure 1. CYW43353 Block Diagram

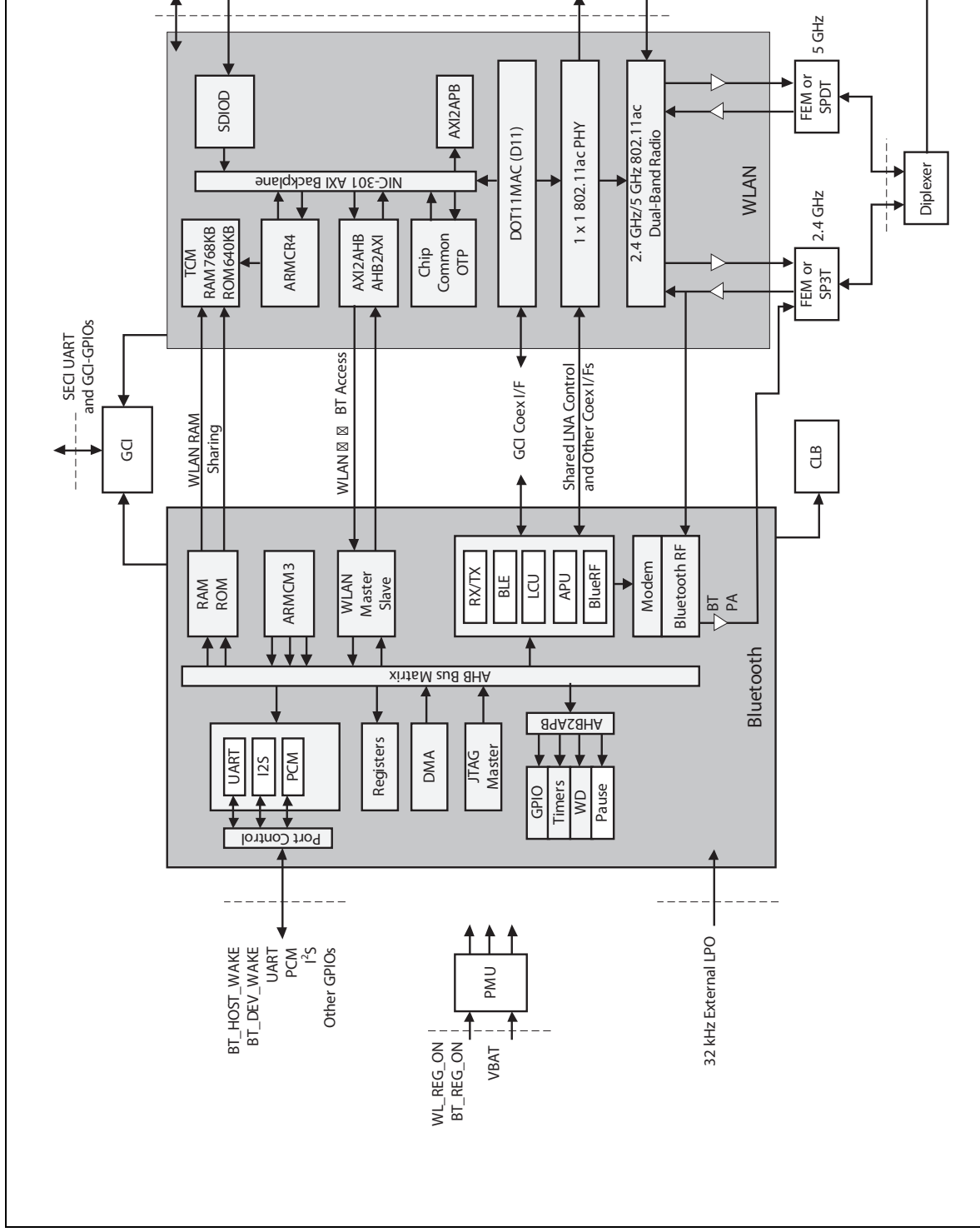

1.2 Features

The CYW43353 supports the following features:

- IEEE 802.11a/b/g/n/ac dual-band radio with virtual-simultaneous dual-band operation
- Bluetooth v4.1 + EDR with integrated Class 1 PA
- Concurrent Bluetooth and WLAN operation
- On-chip WLAN driver execution capable of supporting IEEE 802.11 functionality
- WLAN host interface options:
 - SDIO v3.0 (1-bit/4-bit)—up to 208 MHz clock rate in SDR104 mode
 - gSPI—up to 48 MHz clock rate
- BT host digital interface (which can be used concurrently with the above interfaces):
 - UART (up to 4 Mbps)
- ECI—enhanced coexistence support, ability to coordinate BT SCO transmissions around WLAN receptions
- I²S/PCM for BT audio
- HCI high-speed UART (H4, H4+, H5) transport support
- Wideband speech support (16 bits linear data, MSB first, left justified at 4K samples/s for transparent air coding, both through I²S and PCM interface)
- Bluetooth SmartAudio[®] technology improves voice and music quality for automotive and industrial applications
- Bluetooth low-power inquiry and page scan
- Bluetooth Low Energy (BLE) support
- Bluetooth Packet Loss Concealment (PLC)
- Bluetooth Wide Band Speech (WBS)
- Audio rate-matching algorithms

1.3 Standards Compliance

The CYW43353 supports the following standards:

- Bluetooth 2.1 + EDR
- Bluetooth 3.0
- Bluetooth 4.1 (Bluetooth Low Energy)
- IEEE802.11ac single-stream mandatory and optional requirements for 20 MHz, 40 MHz, and 80 MHz channels
- IEEE 802.11n—Handheld Device Class (Section 11)
- IEEE 802.11a
- IEEE 802.11b
- IEEE 802.11g
- IEEE 802.11d
- IEEE 802.11h
- IEEE 802.11i

- Security:

- WEP
- WPA™ Personal
- WPA2™ Personal
- WMM
- WMM-PS (U-APSD)
- WMM-SA
- AES (Hardware Accelerator)
- TKIP (HW Accelerator)
- CKIP (SW Support)

- Proprietary Protocols:

- CCXv2
- CCXv3
- CCXv4
- CCXv5

- IEEE 802.15.2 Coexistence Compliance—on silicon solution compliant with IEEE 3 wire requirements

The CYW43353 will support the following future drafts/standards:

- IEEE 802.11r—Fast Roaming (between APs)
- IEEE 802.11w—Secure Management Frames
- IEEE 802.11 Extensions:
 - IEEE 802.11e QoS Enhancements (as per the WMM® specification is already supported)
 - IEEE 802.11h 5 GHz Extensions
 - IEEE 802.11i MAC Enhancements
 - IEEE 802.11k Radio Resource Measurement

1.4 Automotive and Industrial Usage Model

The CYW43353 incorporates a number of unique features to simplify integration into automotive and industrial platforms. Its flexible PCM and UART interfaces enable it to transparently connect with existing platform circuits. In addition, the TCXO and LPO inputs allow the use of existing automotive and industrial features to further minimize the size, power, and cost of the complete system.

- The PCM interface provides multiple modes of operation to support both master and slave as well as hybrid interfacing to single or multiple external codec devices.
- The UART interface supports hardware flow control with tight integration to power-control sideband signaling to support the lowest power operation.
- The crystal oscillator interface accommodates any of the typical reference frequencies used by mobile platform architectures.
- The highly linear design of the radio transceiver ensures that the device has the lowest spurious emissions output regardless of the state of operation. It has been fully characterized in the global cellular bands.
- The transceiver design has excellent blocking and intermodulation performance in the presence of a cellular transmission (LTE, GSM®, GPRS, CDMA, WCDMA, or iDEN).

The CYW43353 is designed to directly interface with new and existing automotive and industrial platform designs.

2. Power Supplies and Power Management

2.1 Power Supply Topology

One buck regulator, multiple LDO regulators, and a power management unit (PMU) are integrated into the CYW43353. All regulators are programmable via the PMU. These blocks simplify power supply design for Bluetooth and WLAN functions in embedded designs.

A single VBAT (3.0V to 4.8 DC maximum) and VIO supply (1.8V to 3.3V) can be used, with all additional voltages being provided by the regulators in the CYW43353.

Two control signals, BT_REG_ON and WL_REG_ON, are used to power up the regulators and take the respective section out of reset. The CBUCK CLDO and LNLDO power up when any of the reset signals are deasserted. All regulators are powered down only when both BT_REG_ON and WL_REG_ON are deasserted. The CLDO and LNLDO may be turned off and on based on the dynamic demands of the digital baseband.

The CYW43353 allows for an extremely low power-consumption mode by completely shutting down the CBUCK, CLDO, and LNLDO regulators. When in this state, LPLDO1 and LPLDO2 (which are low-power linear regulators that are supplied by the system VIO supply) provide the CYW43353 with all the voltages it requires, further reducing leakage currents.

2.2 PMU Features

- VBAT to 1.35V (275 mA nominal, 600 mA maximum) Core-Buck (CBUCK) switching regulator
- VBAT to 3.3V (200 mA nominal, 450 mA maximum) LDO3P3
- VBAT to 2.5V (15 mA nominal, 70 mA maximum) BTLDO2P5
- 1.35V to 1.2V (100 mA nominal, 150 mA maximum) LNLDO
- 1.35V to 1.2V (175 mA nominal, 300 mA maximum) CLDO with bypass mode for deep-sleep
- Additional internal LDOs (not externally accessible)

The following figure shows the regulators and a typical power topology.

Figure 2. Typical Power Topology for CYW43353

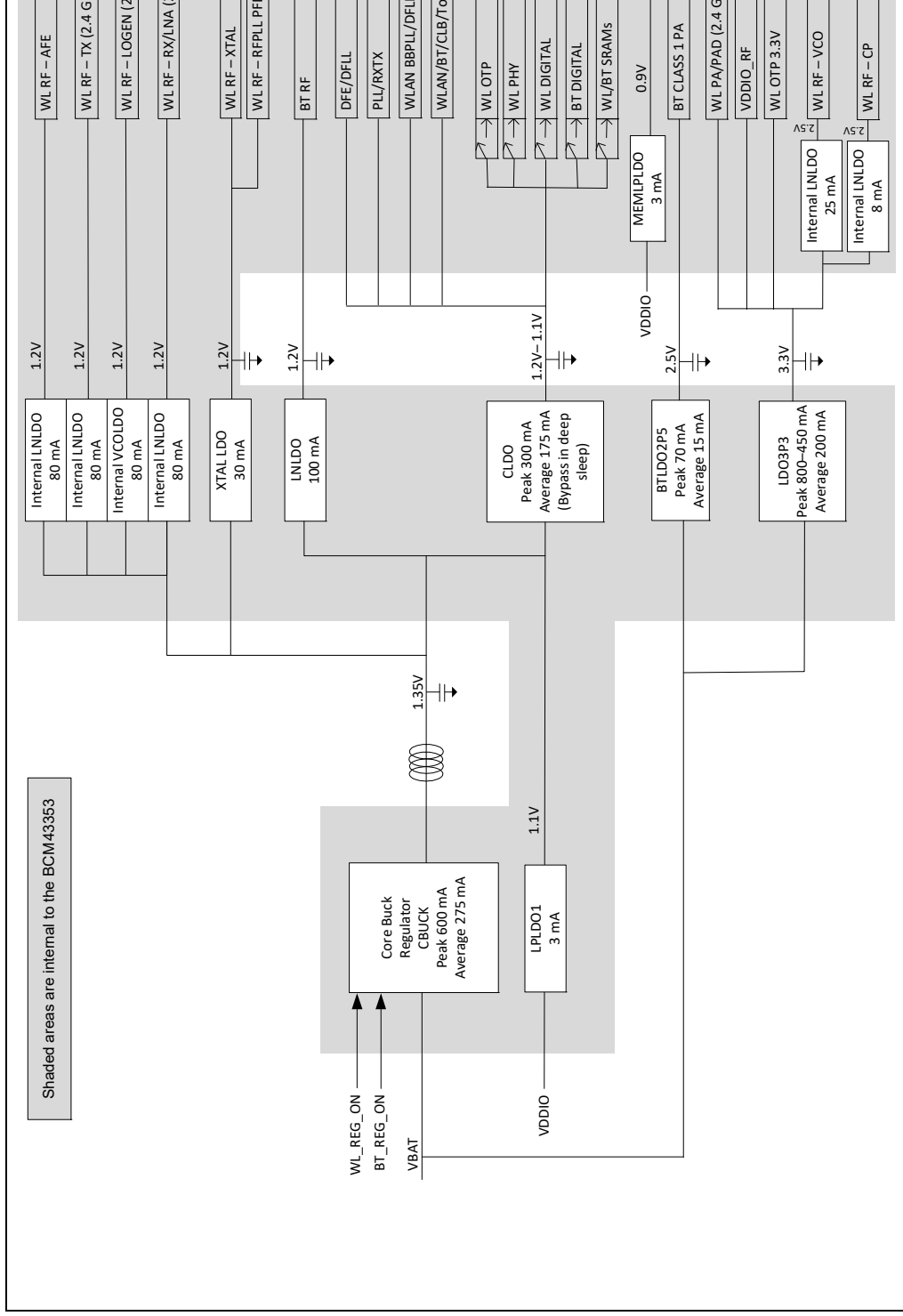

2.3 WLAN Power Management

All areas of the chip design are optimized to minimize power consumption. Silicon processes and cell libraries were chosen to reduce leakage current and supply voltages. Additionally, the CYW43353 integrated RAM is a high Vt memory with dynamic clock control. The dominant supply current consumed by the RAM is leakage current only. Additionally, the CYW43353 includes an advanced WLAN power management unit (PMU) sequencer. The PMU sequencer provides significant power savings by putting the CYW43353 into various power management states appropriate to the current environment and activities that are being performed. The power management unit enables and disables internal regulators, switches, and other blocks based on a computation of the required resources and a table that describes the relationship between resources and the time needed to enable and disable them. Power-up sequences are fully programmable. Configurable, free-running counters (running at the 32.768 kHz LPO clock frequency) in the PMU sequencer are used to turn on and turn off individual regulators and power switches. Clock speeds are dynamically changed (or gated altogether) for the current mode. Slower clock speeds are used wherever possible.

The CYW43353 WLAN power states are described as follows:

- **Active mode**—All WLAN blocks in the CYW43353 are powered up and fully functional with active carrier sensing and frame transmission and receiving. All required regulators are enabled and put in the most efficient mode based on the load current. Clock speeds are dynamically adjusted by the PMU sequencer.
- **Doze mode**—The radio, analog domains, and most of the linear regulators are powered down. The rest of the CYW43353 remains powered up in an IDLE state. All main clocks (PLL, crystal oscillator or TCXO) are shut down to reduce active power consumption to the minimum. The 32.768 kHz LPO clock is available only for the PMU sequencer. This condition is necessary to allow the PMU sequencer to wake up the chip and transition to Active mode. In Doze mode, the primary power consumed is due to leakage current.
- **Deep-sleep mode**—Most of the chip, including both analog and digital domains, and most of the regulators are powered off. Logic states in the digital core are saved and preserved into a retention memory in the always-ON domain before the digital core is powered off. Upon a wake-up event triggered by the PMU timers, an external interrupt, or a host resume through the SDIO bus, logic states in the digital core are restored to their pre-deep-sleep settings to avoid lengthy HW reinitialization.
- **Power-down mode**—The CYW43353 is effectively powered off by shutting down all internal regulators. The chip is brought out of this mode by external logic reenabling the internal regulators.

2.4 PMU Sequencing

The PMU sequencer is responsible for minimizing system power consumption. It enables and disables various system resources based on a computation of the required resources and a table that describes the relationship between resources and the time needed to enable and disable them.

Resource requests may come from several sources: clock requests from cores, the minimum resources defined in the ResourceMin register, and the resources requested by any active resource request timers. The PMU sequencer maps clock requests into a set of resources required to produce the requested clocks.

Each resource is in one of four states (enabled, disabled, transition_on, and transition_off) and has a timer that contains 0 when the resource is enabled or disabled and a nonzero value in the transition states. The timer is loaded with the time_on or time_off value of the resource when the PMU determines that the resource must be enabled or disabled. That timer decrements on each 32.768 kHz PMU clock. When it reaches 0, the state changes from transition_off to disabled or transition_on to enabled. If the time_on value is 0, the resource can go immediately from disabled to enabled. Similarly, a time_off value of 0 indicates that the resource can go immediately from enabled to disabled. The terms enable sequence and disable sequence refer to either the immediate transition or the timer load-decrement sequence.

During each clock cycle, the PMU sequencer performs the following actions:

- Computes the required resource set based on requests and the resource dependency table.
- Decrements all timers whose values are non zero. If a timer reaches 0, the PMU clears the ResourcePending bit for the resource and inverts the ResourceState bit.
- Compares the request with the current resource status and determines which resources must be enabled or disabled.
- Initiates a disable sequence for each resource that is enabled, no longer being requested, and has no powered up dependents.
- Initiates an enable sequence for each resource that is disabled, is being requested, and has all of its dependencies enabled.

2.5 Power-Off Shutdown

The CYW43353 provides a low-power shutdown feature that allows the device to be turned off while the host, and any other devices in the system, remain operational. When the CYW43353 is not needed in the system, VDDIO_RF and VDDC are shut down while VDDIO remains powered. This allows the CYW43353 to be effectively off while keeping the I/O pins powered so that they do not draw extra current from any other devices connected to the I/O.

During a low-power shut-down state, the provided VDDIO remains applied to the CYW43353, all outputs are tristated, and most input signals are disabled. Input voltages must remain within the limits defined for normal operation. This is done to prevent current paths or create loading on any digital signals in the system, and enables the CYW43353 to be fully integrated in an embedded device and take full advantage of the lowest power-savings modes.

When the CYW43353 is powered on from this state, it is the same as a normal power-up, and the device does not retain any information about its state from before it was powered down.

2.6 Power-Up/Power-Down/Reset Circuits

The CYW43353 has two signals (see Table 1) that enable or disable the Bluetooth and WLAN circuits and the internal regulator blocks, allowing the host to control power consumption. For timing diagrams of these signals and the required power-up sequences, see Section 19.: “Power-Up Sequence and Timing”.

Table 1. Power-Up/Power-Down/Reset Control Signals

Signal	Description
WL_REG_ON	This signal is used by the PMU (with BT_REG_ON) to power up the WLAN section. It is also OR-gated with the BT_REG_ON input to control the internal CYW43353 regulators. When this pin is high, the regulators are enabled and the WLAN section is out of reset. When this pin is low, the WLAN section is in reset. If BT_REG_ON and WL_REG_ON are both low, the regulators are disabled. This pin has an internal 200 kΩ pull-down resistor that is enabled by default. It can be disabled through programming.
BT_REG_ON	This signal is used by the PMU (with WL_REG_ON) to decide whether or not to power down the internal CYW43353 regulators. If BT_REG_ON and WL_REG_ON are low, the regulators will be disabled. This pin has an internal 200 kΩ pull-down resistor that is enabled by default. It can be disabled through programming.

3. Frequency References

An external crystal is used for generating all radio frequencies and normal operation clocking. As an alternative, an external frequency reference may be used. In addition, a low-power oscillator (LPO) is provided for lower power mode timing.

3.1 Crystal Interface and Clock Generation

The CYW43353 can use an external crystal to provide a frequency reference. The recommended configuration for the crystal oscillator, including all external components, is shown in [Figure 3](#). Consult the reference schematics for the latest configuration and recommended components.

Figure 3. Recommended Oscillator Configuration

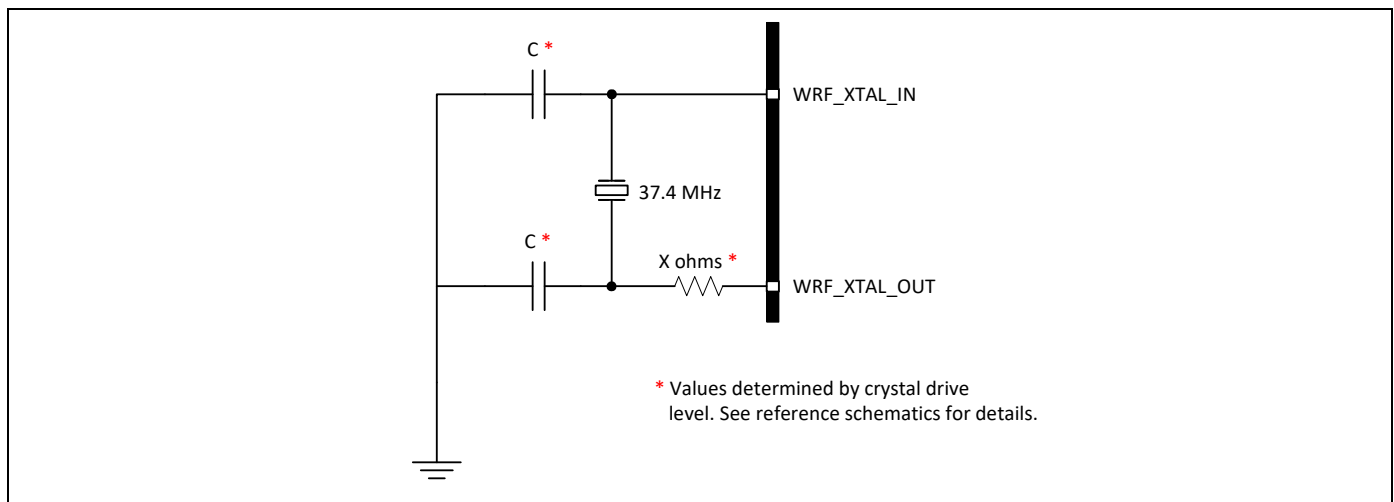

A fractional-N synthesizer in the CYW43353 generates the radio frequencies, clocks, and data/packet timing, enabling the CYW43353 to operate using a wide selection of frequency references.

For SDIO applications, the recommended default frequency reference is a 37.4 MHz crystal. The signal characteristics for the crystal interface are listed in [Table 2](#).

Note: Although the fractional-N synthesizer can support alternative reference frequencies, frequencies other than the default require support to be added in the driver, plus additional extensive system testing. Contact Cypress for details.

3.2 External Frequency Reference

As an alternative to a crystal, an external precision frequency reference can be used. The recommended default frequency is 37.4 MHz. This must meet the phase noise requirements listed in [Table 2](#).

If used, the external clock should be connected to the WRF_XTAL_IN pin through an external 1000 pF coupling capacitor, as shown in [Figure 4](#). The internal clock buffer connected to this pin will be turned off when the CYW43353 goes into sleep mode. When the clock buffer turns on and off, there will be a small impedance variation. Power must be supplied to the WRF_XTAL_BUCK_VDD1P5 pin.

Figure 4. Recommended Circuit to Use with an External Reference Clock

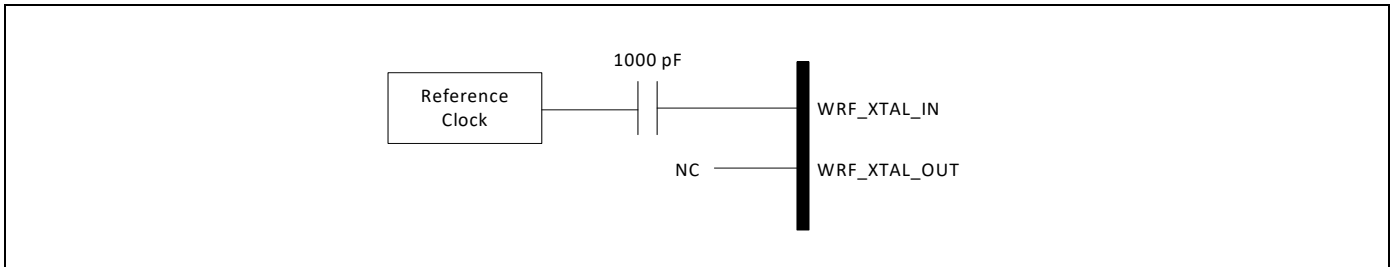

Table 2. Crystal Oscillator and External Clock—Requirements and Performance

Parameter	Conditions/Notes	Crystal ¹			External Frequency Reference ^{2 3}			Units
		Min.	Typ.	Max.	Min.	Typ.	Max.	
Frequency	2.4 GHz and 5 GHz bands, IEEE 802.11ac operation	35	37.4	38.4	–	37.4	–	MHz
Frequency	5 GHz band, IEEE 802.11n operation only	19	37.4	38.4	35	37.4	38.4	MHz
Frequency	2.4 GHz band IEEE 802.11n operation, and both bands legacy 802.11a/b/g operation only	Ranges between 19 MHz and 38.4 MHz ⁴						
Frequency tolerance over the lifetime of the equipment, including temperature ⁵	Without trimming	–20	–	20	–20	–	20	ppm
Crystal load capacitance	–	–	12	–	–	–	–	pF
ESR	–	–	–	60	–	–	–	Ω
Drive level	External crystal must be able to tolerate this drive level.	200	–	–	–	–	–	μW
Input impedance (WRF_XTAL_IN)	Resistive	–	–	–	30k	100k	–	Ω
	Capacitive	–	–	7.5	–	–	7.5	pF
WRF_XTAL_IN input low level	DC-coupled digital signal	–	–	–	0	–	0.2	V
WRF_XTAL_IN input high level	DC-coupled digital signal	–	–	–	1.0	–	1.26	V
WRF_XTAL_IN input voltage (see Figure 4)	AC-coupled analog signal	–	–	–	1000	–	1200	mV _{p-p}
Duty cycle	37.4 MHz clock	–	–	–	40	50	60	%
Phase noise ⁶ (IEEE 802.11b/g)	37.4 MHz clock at 10 kHz offset	–	–	–	–	–	–129	dBc/Hz
	37.4 MHz clock at 100 kHz offset	–	–	–	–	–	–136	dBc/Hz

Table 2. Crystal Oscillator and External Clock—Requirements and Performance (Cont.)

Parameter	Conditions/Notes	Crystal ¹			External Frequency Reference ^{2 3}			Units
		Min.	Typ.	Max.	Min.	Typ.	Max.	
Phase noise ⁶ (IEEE 802.11a)	37.4 MHz clock at 10 kHz offset	–	–	–	–	–	–137	dBc/Hz
	37.4 MHz clock at 100 kHz offset	–	–	–	–	–	–144	dBc/Hz
Phase noise ⁶ (IEEE 802.11n, 2.4 GHz)	37.4 MHz clock at 10 kHz offset	–	–	–	–	–	–134	dBc/Hz
	37.4 MHz clock at 100 kHz offset	–	–	–	–	–	–141	dBc/Hz
Phase noise ⁶ (IEEE 802.11n, 5 GHz)	37.4 MHz clock at 10 kHz offset	–	–	–	–	–	–142	dBc/Hz
	37.4 MHz clock at 100 kHz offset	–	–	–	–	–	–149	dBc/Hz
Phase noise ⁶ (IEEE 802.11ac, 5 GHz)	37.4 MHz clock at 10 kHz offset	–	–	–	–	–	–148	dBc/Hz
	37.4 MHz clock at 100 kHz offset	–	–	–	–	–	–155	dBc/Hz

1. (Crystal) Use WRF_XTAL_IN and WRF_XTAL_OUT.
2. See [External Frequency Reference](#) for alternative connection methods.
3. For a clock reference other than 37.4 MHz, $20 \times \log_{10}(f/37.4)$ dB should be added to the limits, where f = the reference clock frequency in MHz.
4. The frequency step size is approximately 80 Hz.
5. It is the responsibility of the equipment designer to select oscillator components that comply with these specifications.
6. Assumes that external clock has a flat phase-noise response above 100 kHz.

3.3 Frequency Selection

Any frequency within the ranges specified for the crystal and TCXO reference may be used. These include not only the standard mobile platform reference frequencies of 19.2, 19.8, 24, 26, 33.6, 37.4, and 38.4 MHz, but also other frequencies in this range with an approximate resolution of 80 Hz. The CYW43353 must have the reference frequency set correctly in order for any of the UART or PCM interfaces to function correctly, since all bit timing is derived from the reference frequency.

Note: he fractional-N synthesizer can support many reference frequencies. However, frequencies other than the default require support to be added in the driver plus additional, extensive system testing. Contact Cypress for details.

The reference frequency for the CYW43353 may be set in the following ways:

- Set the `xtalfreq=xxxxx` parameter in the `nvrnm.txt` file (used to load the driver) to correctly match the crystal frequency.
- Autodetect any of the standard handset reference frequencies using an external LPO clock.

For applications where the reference frequency is one of the standard frequencies commonly used, the CYW43353 automatically detects the reference frequency and programs itself to the correct reference frequency. In order for automatic frequency detection to work correctly, the CYW43353 must have a valid and stable 32.768 kHz LPO clock that meets the requirements listed in [Table 3](#) and is present during power-on reset.

3.4 External 32.768 kHz Low-Power Oscillator

The CYW43353 uses a secondary low-frequency clock for low-power-mode timing. An external 32.768 kHz precision oscillator is required. Use a precision external 32.768 kHz clock that meets the requirements listed in [Table 3](#).

Table 3. External 32.768 kHz Sleep Clock Specifications

Parameter	LPO Clock	Units
Nominal input frequency	32.768	kHz
Frequency accuracy	±200	ppm
Duty cycle	30–70	%
Input signal amplitude	200–1800	mV, p-p
Signal type	Square-wave or sine-wave	–
Input impedance ¹	>100k <5	Ω pF
Clock jitter (during initial start-up)	<10,000	ppm

1. When power is applied or switched off.

4. Bluetooth Subsystem Overview

The Cypress CYW43353 is a Bluetooth 4.1 + EDR-compliant, baseband processor/2.4 GHz transceiver. It features the highest level of integration and eliminates all critical external components, thus minimizing the footprint, power consumption, and system cost of a Bluetooth solution.

The CYW43353 is the optimal solution for any Bluetooth voice and/or data application. The Bluetooth subsystem presents a standard Host Controller Interface (HCI) via a high-speed UART and PCM for audio. The CYW43353 incorporates all Bluetooth 4.1 features including Secure Simple Pairing, Sniff Subrating, and Encryption Pause and Resume.

The CYW43353 Bluetooth radio transceiver provides enhanced radio performance to meet -40°C to $+85^{\circ}\text{C}$ temperature applications and the tightest integration into automotive and industrial platforms. It is fully compatible with any of the standard TCXO frequencies and provides full radio compatibility to operate simultaneously with GPS, WLAN, and cellular radios.

The Bluetooth transmitter also features a Class 1 power amplifier with Class 2 capability.

4.1 Features

Major Bluetooth features of the CYW43353 include:

- Supports key features of upcoming Bluetooth standards
- Fully supports Bluetooth Core Specification version 4.1 + (Enhanced Data Rate) EDR features:
 - Adaptive Frequency Hopping (AFH)
 - Quality of Service (QoS)
 - Extended Synchronous Connections (eSCO)—Voice Connections
 - Fast Connect (interlaced page and inquiry scans)
 - Secure Simple Pairing (SSP)
 - Sniff Subrating (SSR)
 - Encryption Pause Resume (EPR)
 - Extended Inquiry Response (EIR)
 - Link Supervision Timeout (LST)
- UART baud rates up to 4 Mbps
- Supports Bluetooth 4.1 for automotive and industrial applications
- Supports maximum Bluetooth data rates over HCI UART
- Multipoint operation with up to seven active slaves
 - Maximum of seven simultaneous active ACL links
 - Maximum of three simultaneous active SCO and eSCO connections with scatternet support
- Trigger Cypress fast connect (TBFC)
- Narrowband and wideband packet loss concealment
- Scatternet operation with up to four active piconets with background scan and support for scatter mode
- High-speed HCI UART transport support with low-power out-of-band BT_DEV_WAKE and BT_HOST_WAKE signaling (see [Host Controller Power Management](#))
- Channel quality driven data rate and packet type selection
- Standard Bluetooth test modes
- Extended radio and production test mode features
- Full support for power savings modes

- ❑ Bluetooth clock request
 - ❑ Bluetooth standard sniff
 - ❑ Deep-sleep modes and software regulator shutdown
- TCXO input and autodetection of all standard handset clock frequencies. Also supports a low-power crystal, which can be used during power save mode for better timing accuracy.

4.2 Bluetooth Radio

The CYW43353 has an integrated radio transceiver that has been optimized for use in 2.4 GHz Bluetooth wireless systems. It has been designed to provide low-power, low-cost, robust communications for applications operating in the globally available 2.4 GHz unlicensed ISM band. It is fully compliant with the Bluetooth Radio Specification and EDR specification and meets or exceeds the requirements to provide the highest communication link quality.

4.2.1 Transmit

The CYW43353 features a fully integrated zero-IF transmitter. The baseband transmit data is GFSK-modulated in the modem block and upconverted to the 2.4 GHz ISM band in the transmitter path. The transmitter path performs signal filtering, I/Q upconversion, output power amplification, and RF filtering. The transmitter path also incorporates $\pi/4$ -DQPSK and 8-DPSK modulations for 2 Mbps and 3 Mbps EDR support, respectively. The transmitter section is compatible to the Bluetooth Low Energy specification. The transmitter PA bias can also be adjusted to provide Bluetooth Class 1 or Class 2 operation.

4.2.2 Digital Modulator

The digital modulator performs the data modulation and filtering required for the GFSK, $\pi/4$ -DQPSK, and 8-DPSK signal. The fully digital modulator minimizes any frequency drift or anomalies in the modulation characteristics of the transmitted signal and is much more stable than direct VCO modulation schemes.

4.2.3 Digital Demodulator and Bit Synchronizer

The digital demodulator and bit synchronizer take the low-IF received signal and perform an optimal frequency tracking and bit-synchronization algorithm.

4.2.4 Power Amplifier

The fully integrated PA supports Class 1 or Class 2 output using a highly linearized, temperature-compensated design. This provides greater flexibility in front-end matching and filtering. Due to the linear nature of the PA combined with some integrated filtering, external filtering is required to meet the Bluetooth and regulatory harmonic and spurious requirements. For integrated telematics applications in which Bluetooth is integrated next to the cellular radio, external filtering can be applied to achieve near-thermal-noise levels for spurious and radiated noise emissions. The transmitter features a sophisticated on-chip transmit signal strength indicator (TSSI) block to keep the absolute output power variation within a tight range across process, voltage, and temperature.

4.2.5 Receiver

The receiver path uses a low-IF scheme to downconvert the received signal for demodulation in the digital demodulator and bit synchronizer. The receiver path provides a high degree of linearity, an extended dynamic range, and high-order on-chip channel filtering to ensure reliable operation in the noisy 2.4 GHz ISM band. The front-end topology, with built-in out-of-band attenuation, enables the CYW43353 to be used in most applications with minimal off-chip filtering. For integrated telematics operation, in which the Bluetooth function is integrated close to the cellular transmitter, external filtering is required to eliminate the desensitization of the receiver by the cellular transmit signal.

4.2.6 Digital Demodulator and Bit Synchronizer

The digital demodulator and bit synchronizer take the low-IF received signal and perform an optimal frequency tracking and bit synchronization algorithm.

4.2.7 Receiver Signal Strength Indicator

The radio portion of the CYW43353 provides a Receiver Signal Strength Indicator (RSSI) signal to the baseband, so that the controller can determine whether the transmitter should increase or decrease its output power.

4.2.8 Local Oscillator Generation

Local Oscillator (LO) generation provides fast frequency hopping (1600 hops/second) across the 79 maximum available channels. The LO generation subblock employs an architecture for high immunity to LO pulling during PA operation. The CYW43353 uses an internal RF and IF loop filter.

4.2.9 Calibration

The CYW43353 radio transceiver features an automated calibration scheme that is fully self contained in the radio. No user interaction is required during normal operation or during manufacturing to provide the optimal performance. Calibration optimizes the performance of all the major blocks within the radio to within 2% of optimal conditions, including gain and phase characteristics of filters, matching between key components, and key gain blocks. This takes into account process variation and temperature variation. Calibration occurs during normal operation during the settling time of the hops and calibrates for temperature variations as the device cools and heats during normal operation in its environment.

5. Bluetooth Baseband Core

The Bluetooth Baseband Core (BBC) implements all of the time critical functions required for high-performance Bluetooth operation. The BBC manages the buffering, segmentation, and routing of data for all connections. It also buffers data that passes through it, handles data flow control, schedules SCO/ACL TX/RX transactions, monitors Bluetooth slot usage, optimally segments and packages data into baseband packets, manages connection status indicators, and composes and decodes HCI packets. In addition to these functions, it independently handles HCI event types, and HCI command types.

The following transmit and receive functions are also implemented in the BBC hardware to increase reliability and security of the TX/RX data:

- Symbol timing recovery, data deframing, forward error correction (FEC), header error control (HEC), cyclic redundancy check (CRC), data decryption, and data dewatering in the receiver.
- Data framing, FEC generation, HEC generation, CRC generation, key generation, data encryption, and data whitening in the transmitter.

5.1 Bluetooth 4.1 Features

The BBC supports all Bluetooth 4.1 features, with the following benefits:

- Dual-mode bluetooth Low Energy (BT and BLE operation)
- Extended Inquiry Response (EIR): Shortens the time to retrieve the device name, specific profile, and operating mode.
- Encryption Pause Resume (EPR): Enables the use of Bluetooth technology in a much more secure environment.
- Sniff Subrating (SSR): Optimizes power consumption for low duty cycle asymmetric data flow, which subsequently extends battery life.
- Secure Simple Pairing (SSP): Reduces the number of steps for connecting two devices, with minimal or no user interaction required.
- Link Supervision Time Out (LSTO): Additional commands added to HCI and Link Management Protocol (LMP) for improved link time-out supervision.
- QoS enhancements: Changes to data traffic control, which results in better link performance. Audio, human interface device (HID), bulk traffic, SCO, and enhanced SCO (eSCO) are improved with the erroneous data (ED) and packet boundary flag (PBF) enhancements.

5.2 Bluetooth Low Energy

The CYW43353 supports the Bluetooth Low Energy operating mode.

5.3 Link Control Layer

The link control layer is part of the Bluetooth link control functions that are implemented in dedicated logic in the link control unit (LCU). This layer consists of the command controller that takes commands from the software, and other controllers that are activated or configured by the command controller to perform the link control tasks. Each task performs a different state in the Bluetooth Link Controller.

■ Major states:

- Standby
- Connection

■ Substates:

- Page
- Page Scan
- Inquiry
- Inquiry Scan
- Sniff

5.4 Test Mode Support

The CYW43353 fully supports Bluetooth Test mode as described in Part I:1 of the *Specification of the Bluetooth System Version 3.0*. This includes the transmitter tests, normal and delayed loopback tests, and reduced hopping sequence.

In addition to the standard Bluetooth Test Mode, the CYW43353 also supports enhanced testing features to simplify RF debugging, qualification, and type-approval testing. These features include:

■ Fixed-frequency carrier-wave (unmodulated) transmission

- Simplifies some type-approval measurements (Japan)
- Aids in transmitter performance analysis

■ Fixed-frequency constant-receiver mode

- Receiver output directed to I/O pin
- Allows for direct BER measurements using standard RF test equipment
- Facilitates spurious emissions testing for receive mode

■ Fixed frequency constant transmission

- Eight-bit fixed pattern or PRBS-9
- Enables modulated signal measurements with standard RF test equipment

5.5 Bluetooth Power Management Unit

The Bluetooth Power Management Unit (PMU) provides power management features that can be invoked by either software through power management registers or packet handling in the baseband core. The power management functions provided by the CYW43353 are:

- RF Power Management
- Host Controller Power Management
- BBC Power Management

5.5.1 RF Power Management

The BBC generates power-down control signals to the 2.4 GHz transceiver for the transmit path, receive path, PLL, and power amplifier. The transceiver then processes the power-down functions accordingly.

5.5.2 Host Controller Power Management

When running in UART mode, the CYW43353 may be configured so that dedicated signals are used for power management handshaking between the CYW43353 and the host. The basic power saving functions supported by those handshaking signals include the standard Bluetooth defined power savings modes and standby modes of operation.

Table 4 describes the power-control handshake signals used with the UART interface.

Table 4. Power Control Pin Description

Signal	Mapped to Pin	Type	Description
BT_DEV_WAKE	BT_GPIO_0	I	Bluetooth device wake-up: Signal from the host to the CYW43353 indicating that the host requires attention. <ul style="list-style-type: none"> • Asserted: The Bluetooth device must wake-up or remain awake. • Deasserted: The Bluetooth device may sleep when sleep criteria are met. The polarity of this signal is software configurable and can be asserted high or low.
BT_HOST_WAKE	BT_GPIO_1	O	Host wake up. Signal from the CYW43353 to the host indicating that the CYW43353 requires attention. <ul style="list-style-type: none"> • Asserted: host device must wake-up or remain awake. • Deasserted: host device may sleep when sleep criteria are met. The polarity of this signal is software configurable and can be asserted high or low.
CLK_REQ	BT_CLK_REQ_OUT WL_CLK_REQ_OUT	O	The CYW43353 asserts CLK_REQ when either the Bluetooth or WLAN block wants the host to turn on the reference clock. The CLK_REQ polarity is active-high. Add an external 100 kΩ pull-down resistor to ensure the signal is deasserted when the CYW43353 powers up or resets when VDDIO is present.

Note: Pad function Control Register is set to 0 for these pins. See [DC Characteristics](#) for more details.

Figure 5. Startup Signaling Sequence

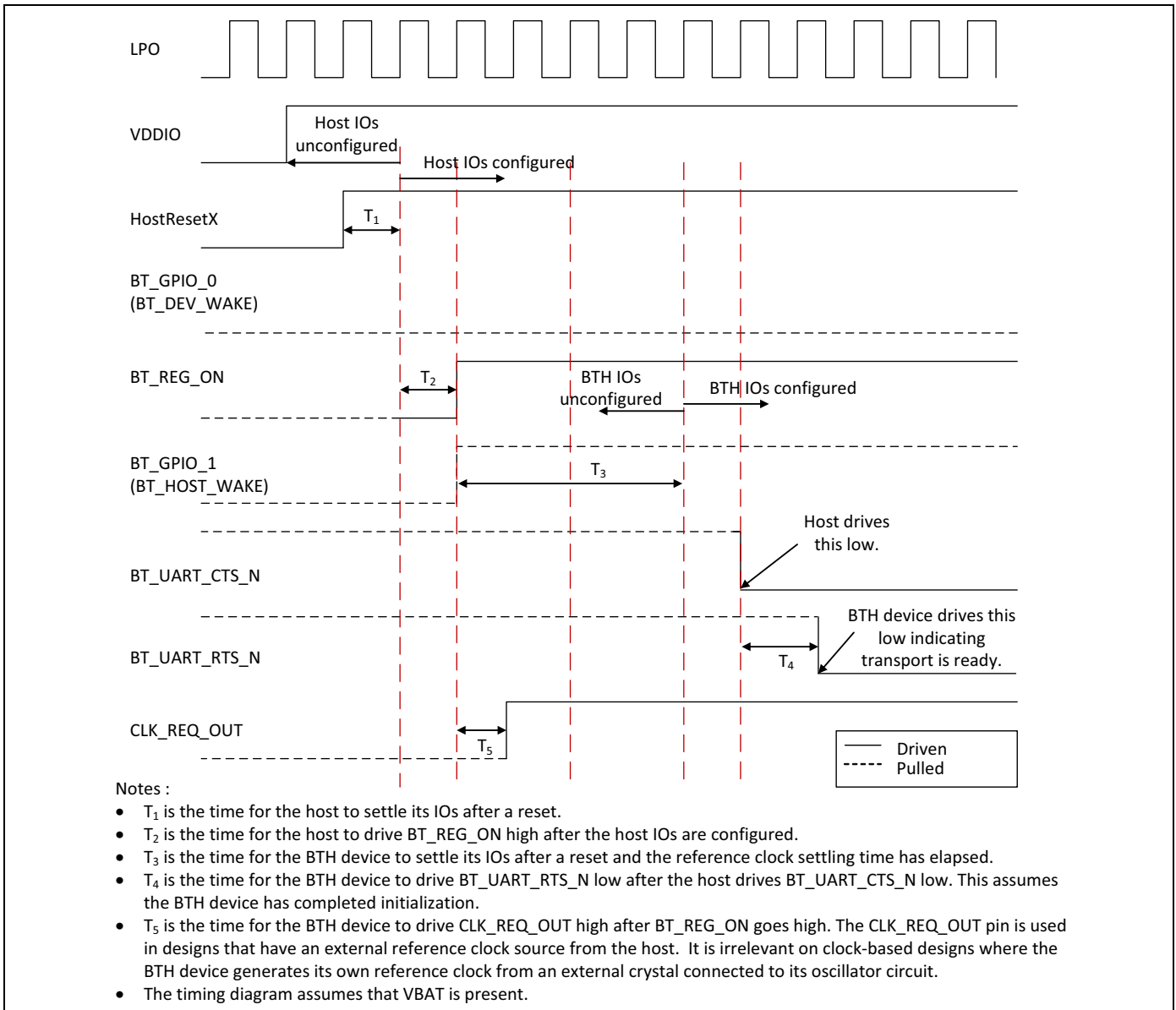

5.5.3 BBC Power Management

The following are low-power operations for the BBC:

- Physical layer packet-handling turns the RF on and off dynamically within transmit/receive packets.
- Bluetooth-specified low-power connection modes: sniff, hold, and park. While in these modes, the CYW43353 runs on the low-power oscillator and wakes up after a predefined time period.
- A low-power shutdown feature allows the device to be turned off while the host and any other devices in the system remain operational. When the CYW43353 is not needed in the system, the RF and core supplies are shut down while the I/O remains powered. This allows the CYW43353 to effectively be off while keeping the I/O pins powered so they do not draw extra current from any other devices connected to the I/O.

During the low-power shut-down state, provided VDDIO remains applied to the CYW43353, all outputs are tristated, and most input signals are disabled. Input voltages must remain within the limits defined for normal operation. This is done to prevent current paths or create loading on any digital signals in the system and enables the CYW43353 to be fully integrated in an embedded device to take full advantage of the lowest power-saving modes.

Two CYW43353 input signals are designed to be high-impedance inputs that do not load the driving signal even if the chip does not have VDDIO power supplied to it: the frequency reference input (WRF_TCXO_IN) and the 32.768 kHz input (LPO). When the CYW43353 is powered on from this state, it is the same as a normal power-up, and the device does not contain any information about its state from the time before it was powered down.

5.5.4 Wideband Speech

The CYW43353 provides support for wideband speech (WBS) using on-chip SmartAudio technology. The CYW43353 can perform subband-codec (SBC), as well as mSBC, encoding and decoding of linear 16 bits at 16 kHz (256 kbps rate) transferred over the PCM bus.

5.5.5 Packet Loss Concealment

Packet Loss Concealment (PLC) improves apparent audio quality for systems with marginal link performance. Bluetooth messages are sent in packets. When a packet is lost, it creates a gap in the received audio bitstream. Packet loss can be mitigated in several ways:

- Fill in zeros.
- Ramp down the output audio signal toward zero (this is the method used in current Bluetooth headsets).
- Repeat the last frame (or packet) of the received bitstream and decode it as usual (frame repeat).

These techniques cause distortion and popping in the audio stream. The CYW43353 uses a proprietary waveform extension algorithm to provide dramatic improvement in the audio quality. [Figure 6](#) and [Figure 7](#) show audio waveforms with and without Packet Loss Concealment. Cypress PLC and bit-error correction (BEC) algorithms also support wideband speech.

Figure 6. CVSD Decoder Output Waveform Without PLC

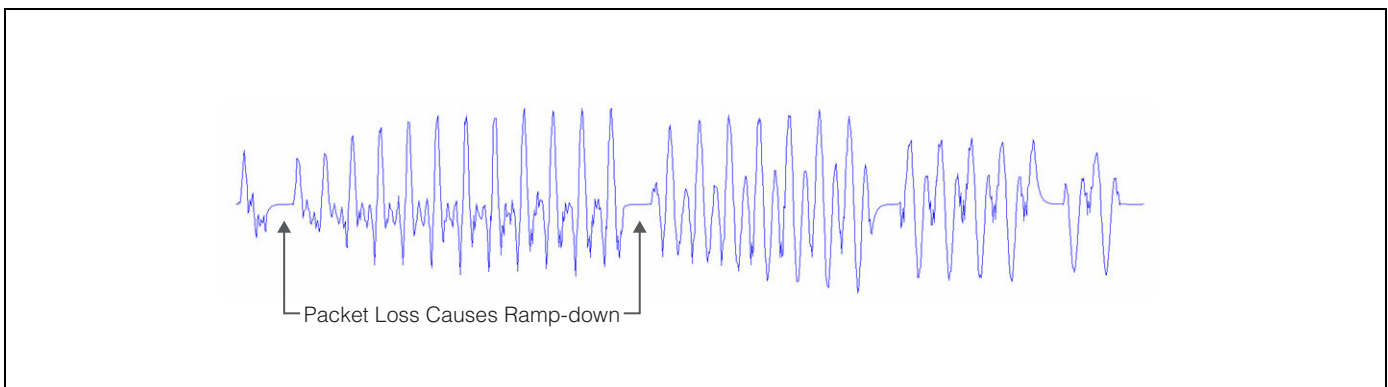
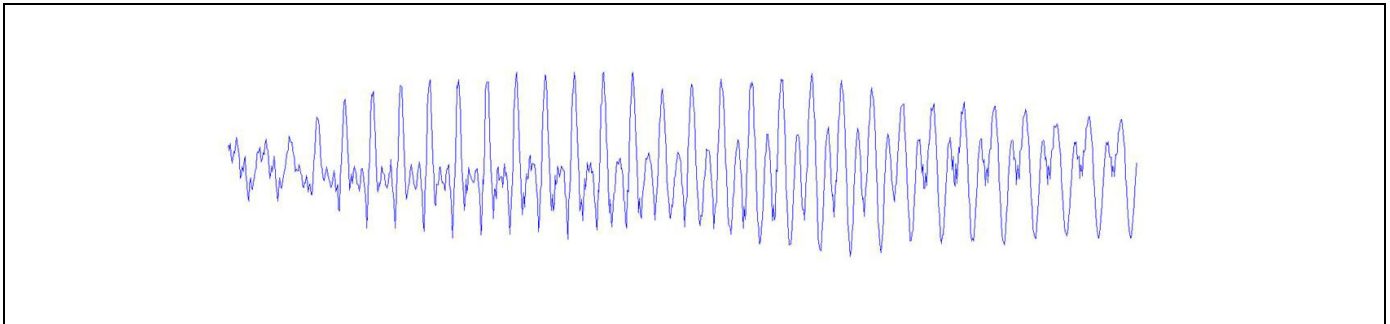

Figure 7. CVSD Decoder Output Waveform After Applying PLC



5.5.6 Audio Rate-Matching Algorithms

The CYW43353 has an enhanced rate-matching algorithm that uses interpolation algorithms to reduce audio stream jitter that may be present when the rate of audio data coming from the host is not the same as the Bluetooth audio data rates.

5.5.7 Codec Encoding

The CYW43353 can support SBC and mSBC encoding and decoding for wideband speech.

5.5.8 Multiple Simultaneous A2DP Audio Streams

The CYW43353 has the ability to take a single audio stream and output it to multiple Bluetooth devices simultaneously. This allows a user to share his or her music (or any audio stream) with a friend.

5.6 Adaptive Frequency Hopping

The CYW43353 gathers link quality statistics on a channel by channel basis to facilitate channel assessment and channel map selection. The link quality is determined using both RF and baseband signal processing to provide a more accurate frequency-hop map.

5.7 Advanced Bluetooth/WLAN Coexistence

The CYW43353 includes advanced coexistence technologies that are only possible with a Bluetooth/WLAN integrated die solution. These coexistence technologies are targeted at small form-factor platforms, such as Automotive and Industrial connectivity systems, including applications such as VoWLAN + SCO and Video-over-WLAN + High Fidelity BT Stereo.

Support is provided for platforms that share a single antenna between Bluetooth and WLAN. The CYW43353 radio architecture allows for lossless simultaneous Bluetooth and WLAN reception for shared antenna applications. This is possible only via an integrated solution (shared LNA and joint AGC algorithm). It has superior performance versus implementations that need to arbitrate between Bluetooth and WLAN reception.

The CYW43353 integrated solution enables MAC-layer signaling (firmware) and a greater degree of sharing via an enhanced coexistence interface. Information is exchanged between the Bluetooth and WLAN cores without host processor involvement.

The CYW43353 also supports Transmit Power Control (TPC) on the STA together with standard Bluetooth TPC to limit mutual interference and receiver desensitization. Preemption mechanisms are utilized to prevent AP transmissions from colliding with Bluetooth frames. Improved channel classification techniques have been implemented in Bluetooth for faster and more accurate detection and elimination of interferers (including non-WLAN 2.4 GHz interference).

The Bluetooth AFH classification is also enhanced by the WLAN core's channel information.

5.8 Fast Connection (Interlaced Page and Inquiry Scans)

The CYW43353 supports page scan and inquiry scan modes that significantly reduce the average inquiry response and connection times. These scanning modes are compatible with the Bluetooth version 2.1 page and inquiry procedures.

6. Microprocessor and Memory Unit for Bluetooth

The Bluetooth microprocessor core is based on the ARM® Cortex-M3™ 32-bit RISC processor with embedded ICE-RT debug and JTAG interface units. It runs software from the link control (LC) layer, up to the host controller interface (HCI).

The ARM core is paired with a memory unit that contains 608 KB of ROM memory for program storage and boot ROM, 192 KB of RAM for data scratch-pad and patch RAM code. The internal ROM allows for flexibility during power-on reset to enable the same device to be used in various configurations. At power-up, the lower-layer protocol stack is executed from the internal ROM memory.

External patches may be applied to the ROM-based firmware to provide flexibility for bug fixes or feature additions. These patches may be downloaded from the host to the CYW43353 through the UART transports.

6.1 RAM, ROM, and Patch Memory

The CYW43353 Bluetooth core has 192 KB of internal RAM which is mapped between general purpose scratch-pad memory and patch memory and 608 KB of ROM used for the lower-layer protocol stack, test mode software, and boot ROM. The patch memory capability enables feature additions and bug fixes to the ROM memory.

6.2 Reset

The CYW43353 has an integrated power-on reset circuit that resets all circuits to a known power-on state. The BT power-on reset (POR) circuit is out of reset after BT_REG_ON goes high. If BT_REG_ON is low, then the POR circuit is held in reset.

7. Bluetooth Peripheral Transport Unit

7.1 PCM Interface

The CYW43353 supports two independent PCM interfaces that share pins with the I²S interfaces. The PCM Interface on the CYW43353 can connect to linear PCM codec devices in master or slave mode. In master mode, the CYW43353 generates the PCM_CLK and PCM_SYNC signals, and in slave mode, these signals are provided by another master on the PCM interface and are inputs to the CYW43353.

The configuration of the PCM interface may be adjusted by the host through the use of vendor-specific HCI commands.

7.1.1 Slot Mapping

The CYW43353 supports up to three simultaneous full-duplex SCO or eSCO channels through the PCM interface. These three channels are time-multiplexed onto the single PCM interface by using a time-slotting scheme where the 8 kHz or 16 kHz audio sample interval is divided into as many as 16 slots. The number of slots is dependent on the selected interface rate of 128 kHz, 512 kHz, or 1024 kHz. The corresponding number of slots for these interface rate is 1, 2, 4, 8, and 16, respectively. Transmit and receive PCM data from an SCO channel is always mapped to the same slot. The PCM data output driver tri-states its output on unused slots to allow other devices to share the same PCM interface signals. The data output driver tristates its output after the falling edge of the PCM clock during the last bit of the slot.

7.1.2 Frame Synchronization

The CYW43353 supports both short- and long-frame synchronization in both master and slave modes. In short-frame synchronization mode, the frame synchronization signal is an active-high pulse at the audio frame rate that is a single-bit period in width and is synchronized to the rising edge of the bit clock. The PCM slave looks for a high on the falling edge of the bit clock and expects the first bit of the first slot to start at the next rising edge of the clock. In long-frame synchronization mode, the frame synchronization signal is again an active-high pulse at the audio frame rate; however, the duration is three bit periods and the pulse starts coincident with the first bit of the first slot.

7.1.3 Data Formatting

The CYW43353 may be configured to generate and accept several different data formats. For conventional narrowband speech mode, the CYW43353 uses 13 of the 16 bits in each PCM frame. The location and order of these 13 bits can be configured to support various data formats on the PCM interface. The remaining three bits are ignored on the input and may be filled with 0s, 1s, a sign bit, or a programmed value on the output. The default format is 13-bit 2's complement data, left justified, and clocked MSB first.

7.1.4 Wideband Speech Support

When the host encodes Wideband Speech (WBS) packets in transparent mode, the encoded packets are transferred over the PCM bus for an eSCO voice connection. In this mode, the PCM bus is typically configured in master mode for a 4 kHz sync rate with 16-bit samples, resulting in a 64 Kbps bit rate. The CYW43353 also supports slave transparent mode using a proprietary rate-matching scheme. In SBC-code mode, linear 16-bit data at 16 kHz (256 Kbps rate) is transferred over the PCM bus.

7.1.5 Multiplexed Bluetooth Over PCM

To support multiple Bluetooth audio streams within the Bluetooth channel, both 16 kHz and 8 kHz streams can be multiplexed. This mode of operation is only supported when the Bluetooth host is the master. [Figure 8](#) shows the operation of the multiplexed transport with three simultaneous SCO connections. To accommodate additional SCO channels, the transport clock speed is increased. To change between modes of operation, the transport must be halted and restarted in the new configuration.

Figure 8. Functional Multiplex Data Diagram

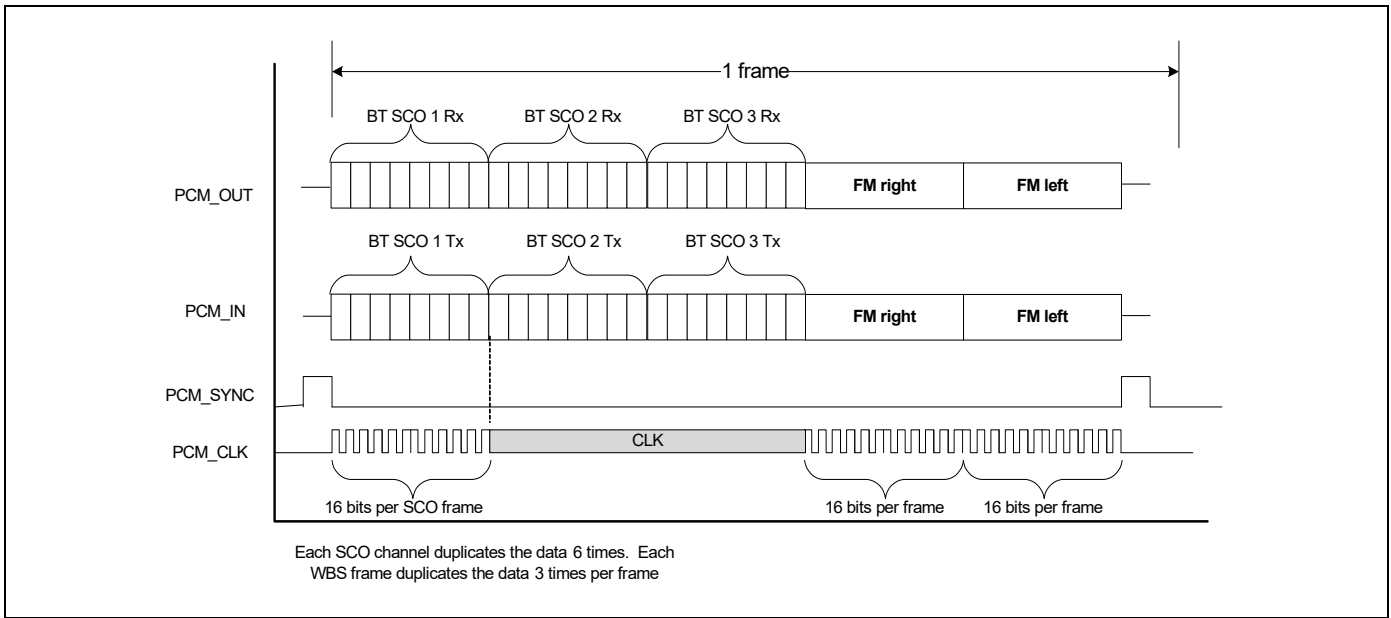

7.1.6 PCM Interface Timing

7.1.6.1. Short Frame Sync, Master Mode

Figure 9. PCM Timing Diagram (Short Frame Sync, Master Mode)

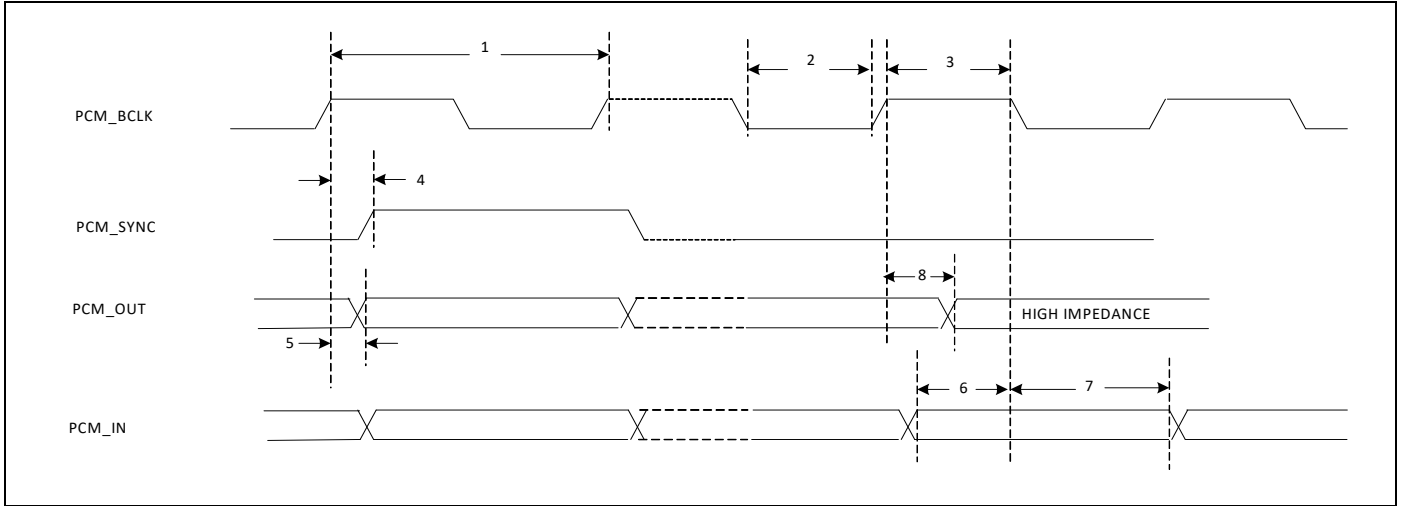

Table 5. PCM Interface Timing Specifications (Short Frame Sync, Master Mode)

Ref No.	Characteristics	Minimum	Typical	Maximum	Unit
1	PCM bit clock frequency	–	–	12	MHz
2	PCM bit clock LOW	41	–	–	ns
3	PCM bit clock HIGH	41	–	–	ns
4	PCM_SYNC delay	0	–	25	ns
5	PCM_OUT delay	0	–	25	ns
6	PCM_IN setup	8	–	–	ns
7	PCM_IN hold	8	–	–	ns
8	Delay from rising edge of PCM_BCLK during last bit period to PCM_OUT becoming high impedance	0	–	25	ns

7.1.6.2. Short Frame Sync, Slave Mode

Figure 10. PCM Timing Diagram (Short Frame Sync, Slave Mode)

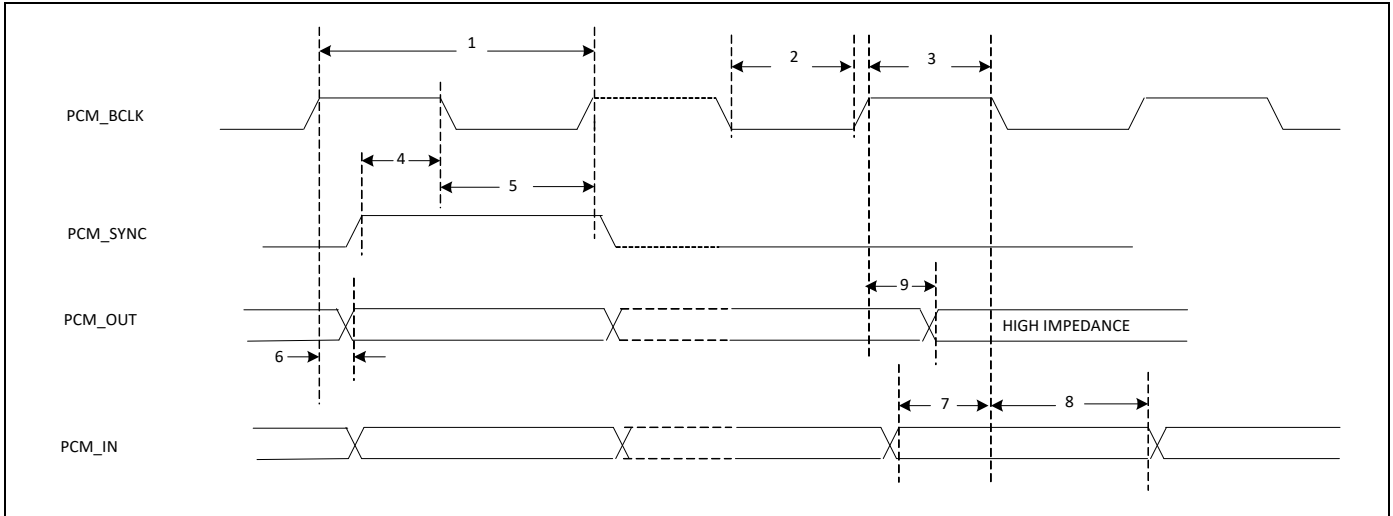

Table 6. PCM Interface Timing Specifications (Short Frame Sync, Slave Mode)

Ref No.	Characteristics	Minimum	Typical	Maximum	Unit
1	PCM bit clock frequency	–	–	12	MHz
2	PCM bit clock LOW	41	–	–	ns
3	PCM bit clock HIGH	41	–	–	ns
4	PCM_SYNC setup	8	–	–	ns
5	PCM_SYNC hold	8	–	–	ns
6	PCM_OUT delay	0	–	25	ns
7	PCM_IN setup	8	–	–	ns
8	PCM_IN hold	8	–	–	ns
9	Delay from rising edge of PCM_BCLK during last bit period to PCM_OUT becoming high impedance	0	–	25	ns

7.1.6.3. Long Frame Sync, Master Mode

Figure 11. PCM Timing Diagram (Long Frame Sync, Master Mode)

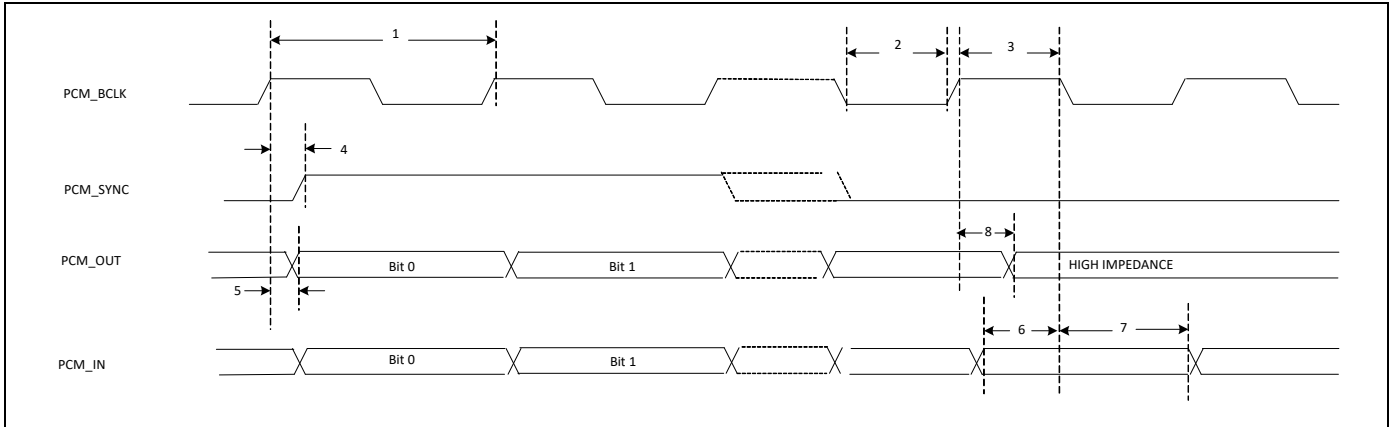

Table 7. PCM Interface Timing Specifications (Long Frame Sync, Master Mode)

Ref No.	Characteristics	Minimum	Typical	Maximum	Unit
1	PCM bit clock frequency	–	–	12	MHz
2	PCM bit clock LOW	41	–	–	ns
3	PCM bit clock HIGH	41	–	–	ns
4	PCM_SYNC delay	0	–	25	ns
5	PCM_OUT delay	0	–	25	ns
6	PCM_IN setup	8	–	–	ns
7	PCM_IN hold	8	–	–	ns
8	Delay from rising edge of PCM_BCLK during last bit period to PCM_OUT becoming high impedance	0	–	25	ns

7.1.6.4. Long Frame Sync, Slave Mode

Figure 12. PCM Timing Diagram (Long Frame Sync, Slave Mode)

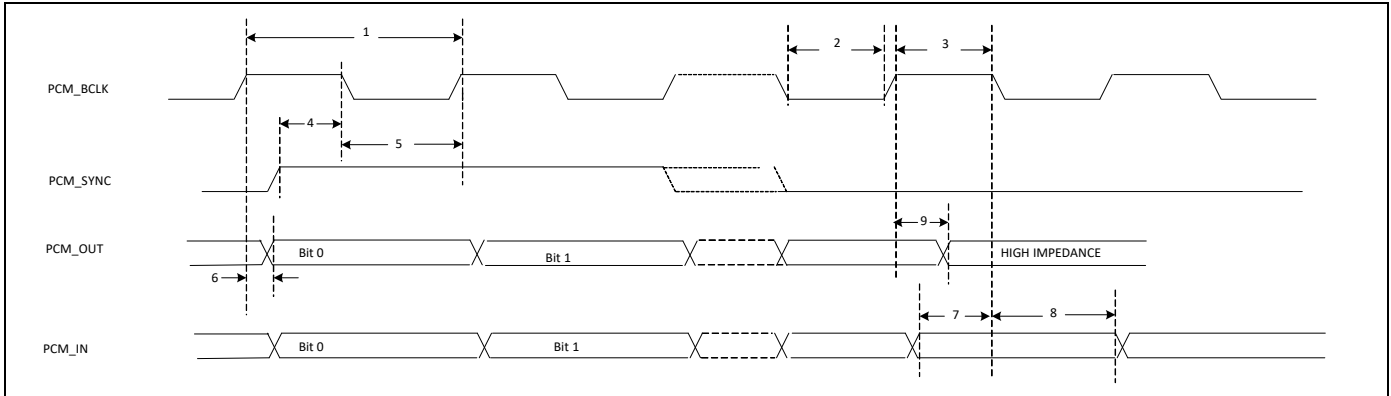

Table 8. PCM Interface Timing Specifications (Long Frame Sync, Slave Mode)

Ref No.	Characteristics	Minimum	Typical	Maximum	Unit
1	PCM bit clock frequency	–	–	12	MHz
2	PCM bit clock LOW	41	–	–	ns
3	PCM bit clock HIGH	41	–	–	ns
4	PCM_SYNC setup	8	–	–	ns
5	PCM_SYNC hold	8	–	–	ns
6	PCM_OUT delay	0	–	25	ns
7	PCM_IN setup	8	–	–	ns
8	PCM_IN hold	8	–	–	ns
9	Delay from rising edge of PCM_BCLK during last bit period to PCM_OUT becoming high impedance	0	–	25	ns

7.2 UART Interface

The UART is a standard 4-wire interface (RX, TX, RTS, and CTS) with adjustable baud rates from 9600 bps to 4.0 Mbps. The interface features an automatic baud rate detection capability that returns a baud rate selection. Alternatively, the baud rate may be selected through a vendor-specific UART HCI command.

UART has a 1040-byte receive FIFO and a 1040-byte transmit FIFO to support EDR. Access to the FIFOs is conducted through the AHB interface through either DMA or the CPU. The UART supports the Bluetooth 4.1 UART HCI specification: H4, a custom Extended H4, and H5. The default baud rate is 115.2 Kbaud.

The UART supports the 3-wire H5 UART transport, as described in the Bluetooth specification (“Three-wire UART Transport Layer”). Compared to H4, the H5 UART transport reduces the number of signal lines required by eliminating the CTS and RTS signals.

The CYW43353 UART can perform XON/XOFF flow control and includes hardware support for the Serial Line Input Protocol (SLIP). It can also perform wake-on activity. For example, activity on the RX or CTS inputs can wake the chip from a sleep state.

Normally, the UART baud rate is set by a configuration record downloaded after device reset, or by automatic baud rate detection, and the host does not need to adjust the baud rate. Support for changing the baud rate during normal HCI UART operation is included through a vendor-specific command that allows the host to adjust the contents of the baud rate registers. The CYW43353 UARTs operate correctly with the host UART as long as the combined baud rate error of the two devices is within $\pm 2\%$.

Table 9. Example of Common Baud Rates

Desired Rate	Actual Rate	Error (%)
4000000	4000000	0.00
3692000	3692308	0.01
3000000	3000000	0.00
2000000	2000000	0.00
1500000	1500000	0.00
1444444	1454544	0.70
921600	923077	0.16
460800	461538	0.16
230400	230796	0.17
115200	115385	0.16
57600	57692	0.16
38400	38400	0.00
28800	28846	0.16
19200	19200	0.00
14400	14423	0.16
9600	9600	0.00

Figure 13. UART Timing

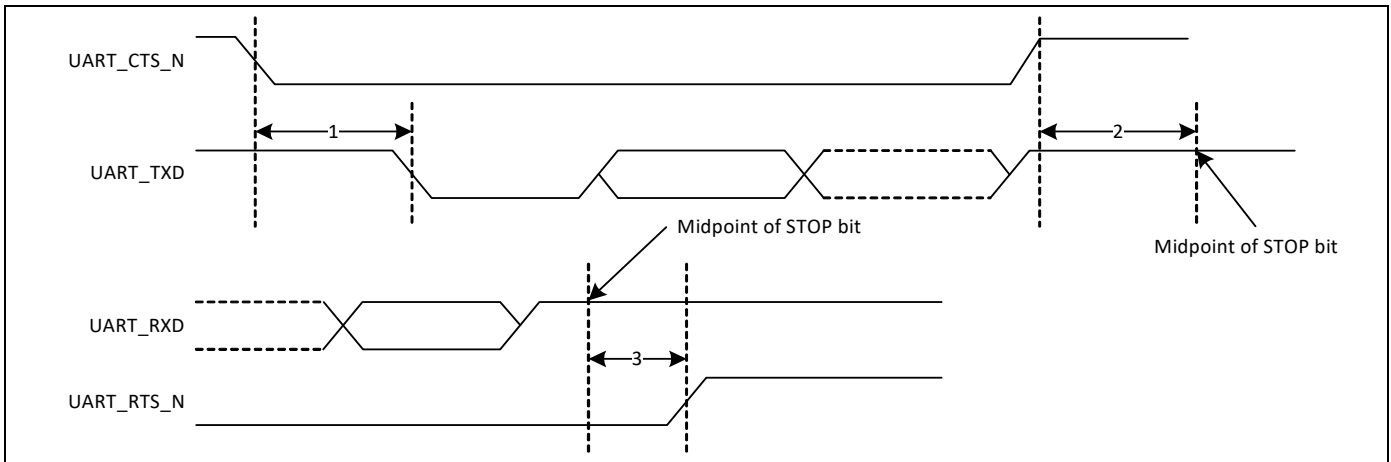

Table 10. UART Timing Specifications

Ref No.	Characteristics	Min.	Typ.	Max.	Unit
1	Delay time, UART_CTS_N low to UART_TXD valid	–	–	1.5	Bit period
2	Setup time, UART_CTS_N high before midpoint of stop bit	–	–	0.5	Bit period
3	Delay time, midpoint of stop bit to UART_RTS_N high	–	–	0.5	Bit period

7.3 I²S Interface

The CYW43353 supports two independent I²S digital audio ports. The I²S signals are:

- I²S clock: I²S SCK
- I²S Word Select: I²S WS
- I²S Data Out: I²S SDO
- I²S Data In: I²S SDI

I²S SCK and I²S WS become outputs in master mode and inputs in slave mode, while I²S SDO always stays as an output. The channel word length is 16 bits and the data is justified so that the MSB of the left-channel data is aligned with the MSB of the I²S bus, per the I²S specification. The MSB of each data word is transmitted one bit clock cycle after the I²S WS transition, synchronous with the falling edge of bit clock. Left-channel data is transmitted when I²S WS is low, and right-channel data is transmitted when I²S WS is high. Data bits sent by the CYW43353 are synchronized with the falling edge of I2S_SCK and should be sampled by the receiver on the rising edge of I2S_SSCK.

The clock rate in master mode is either of the following:

48 kHz x 32 bits per frame = 1.536 MHz

48 kHz x 50 bits per frame = 2.400 MHz

The master clock is generated from the input reference clock using a N/M clock divider.

In the slave mode, any clock rate is supported to a maximum of 3.072 MHz.

7.3.1 I²S Timing

Note: Timing values specified in Table 11 are relative to high and low threshold levels.

Table 11. Timing for I²S Transmitters and Receivers

	Transmitter				Receiver				Notes
	Lower Limit		Upper Limit		Lower Limit		Upper Limit		
	Min.	Max.	Min.	Max.	Min.	Max.	Min.	Max.	
Clock Period T	T _{tr}	–	–	–	T _r	–	–	–	1
Master Mode: Clock generated by transmitter or receiver									
HIGH t _{HC}	0.35T _{tr}	–	–	–	0.35T _{tr}	–	–	–	2
LOW t _{LC}	0.35T _{tr}	–	–	–	0.35T _{tr}	–	–	–	2
Slave Mode: Clock accepted by transmitter or receiver									
HIGH t _{HC}	–	0.35T _{tr}	–	–	–	0.35T _{tr}	–	–	3
LOW t _{LC}	–	0.35T _{tr}	–	–	–	0.35T _{tr}	–	–	3
Rise time t _{RC}	–	–	0.15T _{tr}	–	–	–	–	–	4
Transmitter									
Delay t _{dtr}	–	–	–	0.8T	–	–	–	–	5
Hold time t _{htr}	0	–	–	–	–	–	–	–	4
Receiver									
Setup time t _{sr}	–	–	–	–	–	0.2T _r	–	–	6
Hold time t _{hr}	–	–	–	–	–	0	–	–	6

1. The system clock period T must be greater than T_{tr} and T_r because both the transmitter and receiver have to be able to handle the data transfer rate.
2. At all data rates in master mode, the transmitter or receiver generates a clock signal with a fixed mark/space ratio. For this reason, t_{HC} and t_{LC} are specified with respect to T .
3. In slave mode, the transmitter and receiver need a clock signal with minimum HIGH and LOW periods so that they can detect the signal. So long as the minimum periods are greater than $0.35T_r$, any clock that meets the requirements can be used.
4. Because the delay (t_{dtr}) and the maximum transmitter speed (defined by T_{tr}) are related, a fast transmitter driven by a slow clock edge can result in t_{dtr} not exceeding t_{RC} which means t_{htr} becomes zero or negative. Therefore, the transmitter has to guarantee that t_{htr} is greater than or equal to zero, so long as the clock rise-time t_{RC} is not more than t_{RCmax} , where t_{RCmax} is not less than $0.15T_{tr}$.
5. To allow data to be clocked out on a falling edge, the delay is specified with respect to the rising edge of the clock signal and T , always giving the receiver sufficient setup time.
6. The data setup and hold time must not be less than the specified receiver setup and hold time.

Note: The time periods specified in Figure 14 and Figure 15 are defined by the transmitter speed. The receiver specifications must match transmitter performance.

Figure 14. I²S Transmitter Timing

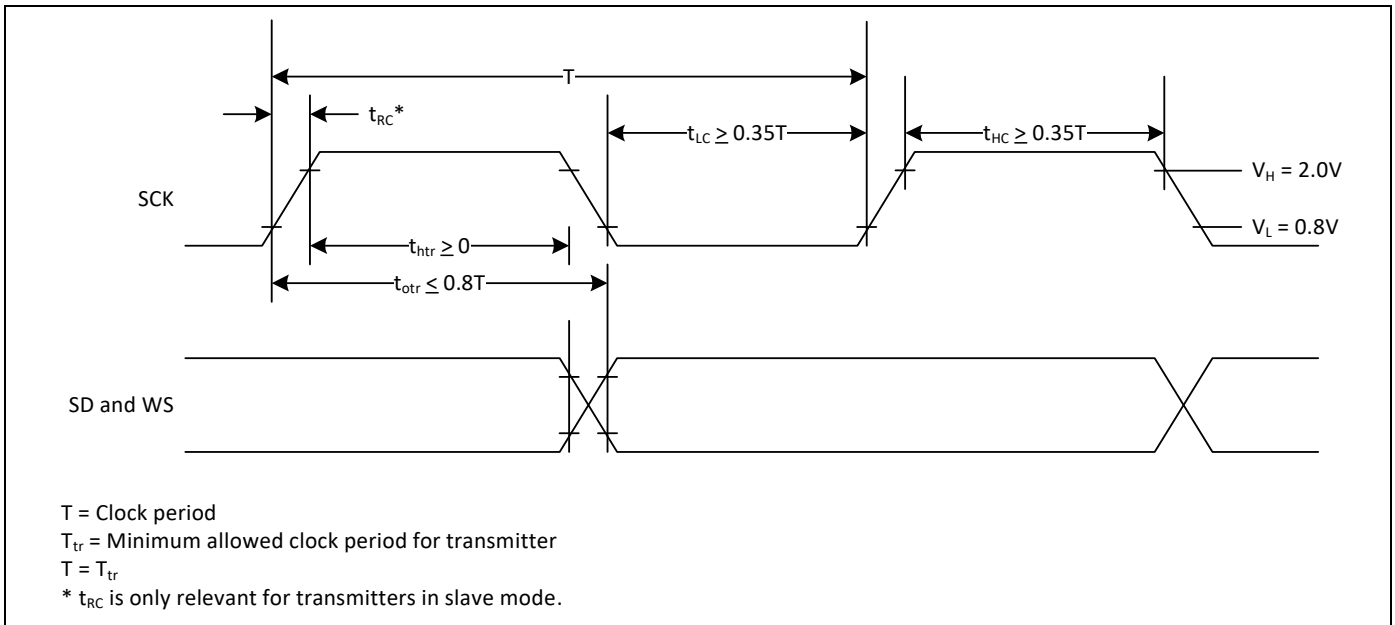
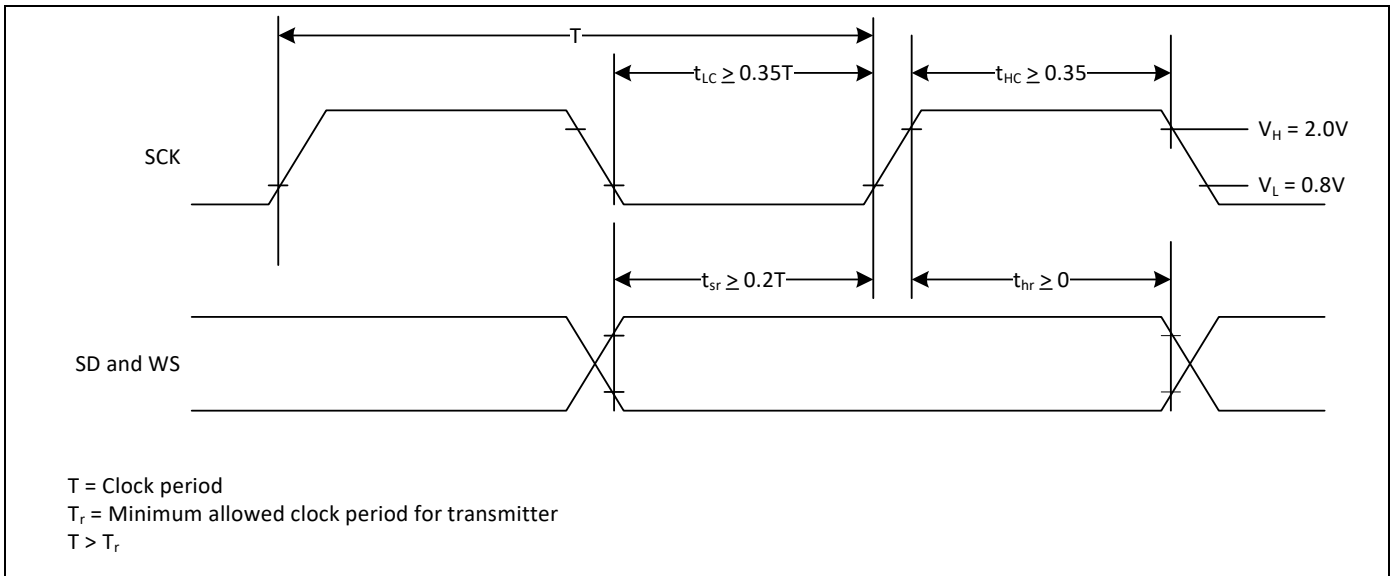

Figure 15. I²S Receiver Timing



8. WLAN Global Functions

8.1 WLAN CPU and Memory Subsystem

The CYW43353 WLAN section includes an integrated ARM Cortex-R4™ 32-bit processor with internal RAM and ROM. The ARM Cortex-R4 is a low-power processor that features low gate count, low interrupt latency, and low-cost debug capabilities. It is intended for deeply embedded applications that require fast interrupt response features. Delivering more than 30% performance gain over ARM7TDMI, the ARM Cortex-R4 implements the ARM v7-R architecture with support for the Thumb®-2 instruction set.

At 0.19 $\mu\text{W}/\text{MHz}$, the Cortex-R4 is the most power efficient general-purpose microprocessor available, outperforming 8- and 16-bit devices on MIPS/ μW . It supports integrated sleep modes.

Using multiple technologies to reduce cost, the ARM Cortex-R4 offers improved memory utilization, reduced pin overhead, and reduced silicon area. It supports independent buses for Code and Data access (ICode/DCode and System buses), and extensive debug features including real time trace of program execution.

On-chip memory for the CPU includes 768 KB SRAM and 640 KB ROM.

8.2 One-Time Programmable Memory

Various hardware configuration parameters may be stored in an internal One-Time Programmable (OTP) memory, which is read by the system software after device reset. In addition, customer-specific parameters, including the system vendor ID and the MAC address can be stored, depending on the specific board design. Customer accessible OTP memory is 502 bytes.

The initial state of all bits in an unprogrammed OTP device is 0. After any bit is programmed to a 1, it cannot be reprogrammed to 0. The entire OTP array can be programmed in a single write cycle using a utility provided with the Cypress WLAN manufacturing test tools. Alternatively, multiple write cycles can be used to selectively program specific bytes, but only bits which are still in the 0 state can be altered during each programming cycle.

Prior to OTP memory programming, all values should be verified using the appropriate editable nvram.txt file, which is provided with the reference board design package.

8.3 GPIO Interface

The following number of general-purpose I/O (GPIO) pins are available on the WLAN section of the CYW43353 that can be used to connect to various external devices:

- WLBGA package – 9 GPIOs

Upon power up and reset, these pins become tristated. Subsequently, they can be programmed to be either input or output pins via the GPIO control register. In addition, the GPIO pins can be assigned to various other functions (see [Table 21, “CYW43353 GPIO/SDIO Alternative Signal Functions,”](#)).

8.4 External Coexistence Interface

An external handshake interface is available to enable signaling between the device and an external co-located wireless device, such as GPS, WiMAX, LTE, or UWB, to manage wireless medium sharing for optimum performance.

Figure 16 shows the LTE coexistence interface. See Table 21, “CYW43353 GPIO/SDIO Alternative Signal Functions,” for details on multiplexed signals such as the GPIO pins.

See Table 9, “Example of Common Baud Rates,” for UART baud rates.

Figure 16. Cypress GCI or BT-SIG Mode LTE Coexistence Interface for CYW43353

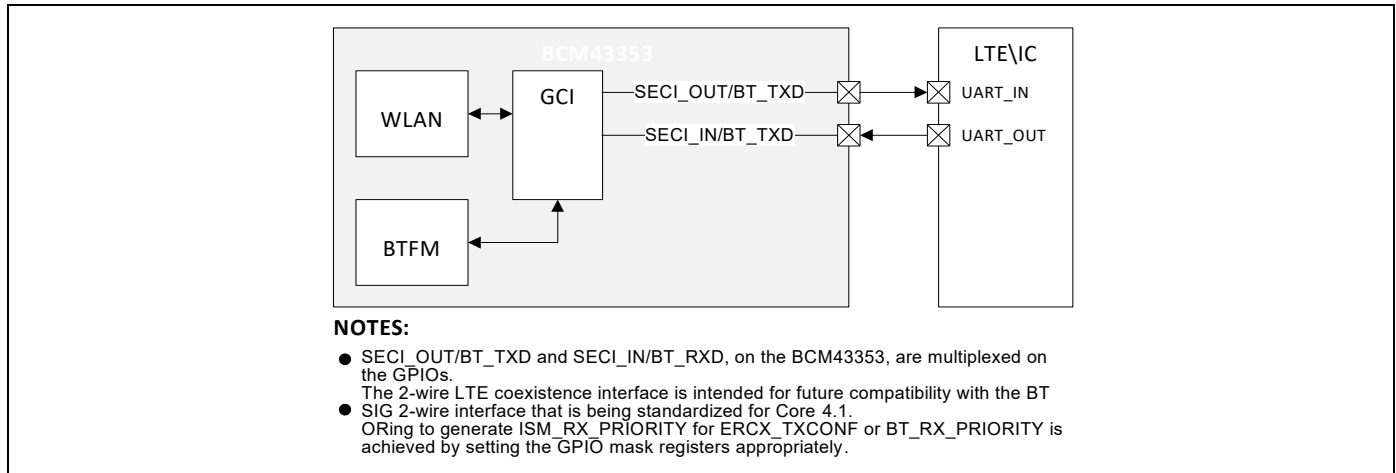

8.5 UART Interface

One 2-wire UART interface can be enabled by software as an alternate function on GPIO pins (see Table 21, “CYW43353 GPIO/SDIO Alternative Signal Functions.”). Provided primarily for debugging during development, this UART enables the CYW43353 to operate as RS-232 data termination equipment (DTE) for exchanging and managing data with other serial devices. It is compatible with the industry standard 16550 UART, and provides a FIFO size of 64 × 8 in each direction.

8.6 JTAG Interface

The CYW43353 supports the IEEE 1149.1 JTAG boundary scan standard for performing device package and PCB assembly testing during manufacturing. In addition, the JTAG interface allows Cypress to assist customers by using proprietary debug and characterization test tools during board bringup. Therefore, it is highly recommended to provide access to the JTAG pins by means of test points or a header on all PCB designs.

See Table 21, “CYW43353 GPIO/SDIO Alternative Signal Functions,” for JTAG pin assignments.

9. WLAN Host Interfaces

9.1 SDIO v3.0

The CYW43353 WLAN section supports SDIO version 3.0, including the new UHS-I modes:

- DS: Default speed (DS) up to 25 MHz, including 1- and 4-bit modes (3.3V signaling).
- HS: High speed up to 50 MHz (3.3V signaling).
- SDR12: SDR up to 25 MHz (1.8V signaling).
- SDR25: SDR up to 50 MHz (1.8V signaling).
- SDR50: SDR up to 100 MHz (1.8V signaling).
- SDR104: SDR up to 208 MHz (1.8V signaling).
- DDR50: DDR up to 50 MHz (1.8V signaling).

Note: The CYW43353 is backward compatible with SDIO v2.0 host interfaces.

The SDIO interface also has the ability to map the interrupt signal on to a GPIO pin for applications requiring an interrupt different from the one provided by the SDIO interface. The ability to force control of the gated clocks from within the device is also provided. SDIO mode is enabled by strapping options. Refer to [Table 16 WLAN GPIO Functions and Strapping Options](#).

The following three functions are supported:

- Function 0 Standard SDIO function (Max. BlockSize/ByteCount = 32B)
- Function 1 Backplane Function to access the internal system-on-chip (SoC) address space (Max. BlockSize/ByteCount = 64B)
- Function 2 WLAN Function for efficient WLAN packet transfer through DMA (Max. BlockSize/ByteCount = 512B)

9.1.1 SDIO Pins

Table 12. SDIO Pin Description

SD 4-Bit Mode		SD 1-Bit Mode		gSPI Mode	
DATA0	Data line 0	DATA	Data line	DO	Data output
DATA1	Data line 1 or Interrupt	IRQ	Interrupt	IRQ	Interrupt
DATA2	Data line 2 or Read Wait	RW	Read Wait	NC	Not used
DATA3	Data line 3	N/C	Not used	CS	Card select
CLK	Clock	CLK	Clock	SCLK	Clock
CMD	Command line	CMD	Command line	DI	Data input

Figure 17. Signal Connections to SDIO Host (SD 4-Bit Mode)

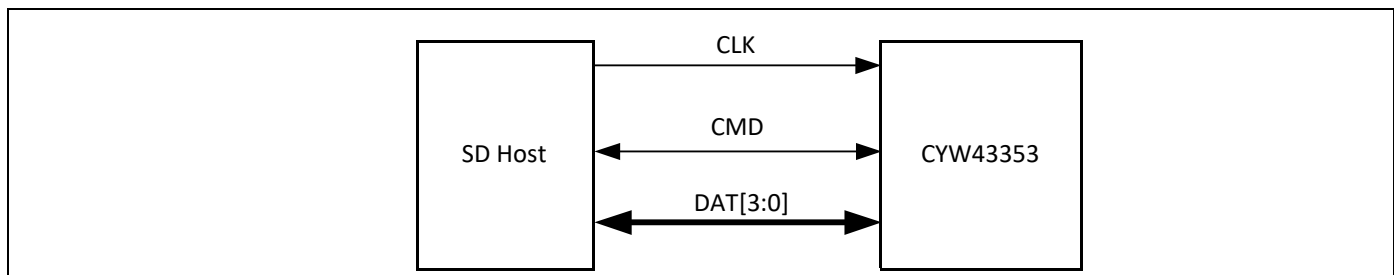
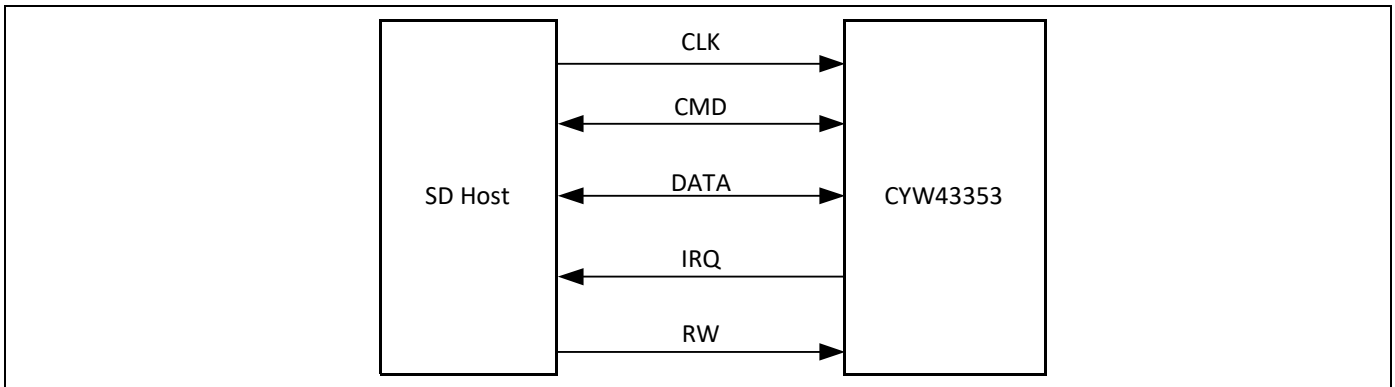

Figure 18. Signal Connections to SDIO Host (SD 1-Bit Mode)



Note: Per Section 6 of the SDIO specification, pull-ups in the 10 kΩ to 100 kΩ range are required on the four DATA lines and the CMD line. This requirement must be met during all operating states either through the use of external pull-up resistors or through proper programming of the SDIO host’s internal pull-ups

9.2 Generic SPI Mode

In addition to the full SDIO mode, the CYW43353 includes the option of using the simplified generic SPI (gSPI) interface/protocol. Characteristics of the gSPI mode include:

- Supports up to 48 MHz operation
- Supports fixed delays for responses and data from device
- Supports alignment to host gSPI frames (16 or 32 bits)
- Supports up to 2 KB frame size per transfer
- Supports little endian (default) and big endian configurations
- Supports configurable active edge for shifting
- Supports packet transfer through DMA for WLAN

gSPI mode is enabled using the strapping option pins strap_host_ifc_[3:1].

Figure 19. Signal Connections to SDIO Host (gSPI Mode)

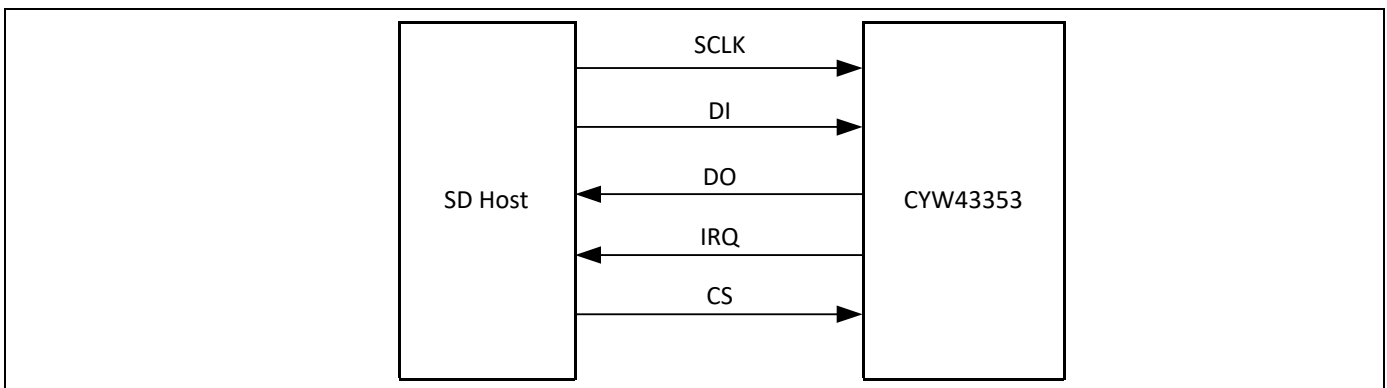

9.2.1 SPI Protocol

The SPI protocol supports both 16-bit and 32-bit word operation. Byte endianness is supported in both modes. Figure 20 and Figure 21 show the basic write and write/read commands.

Figure 20. gSPI Write Protocol

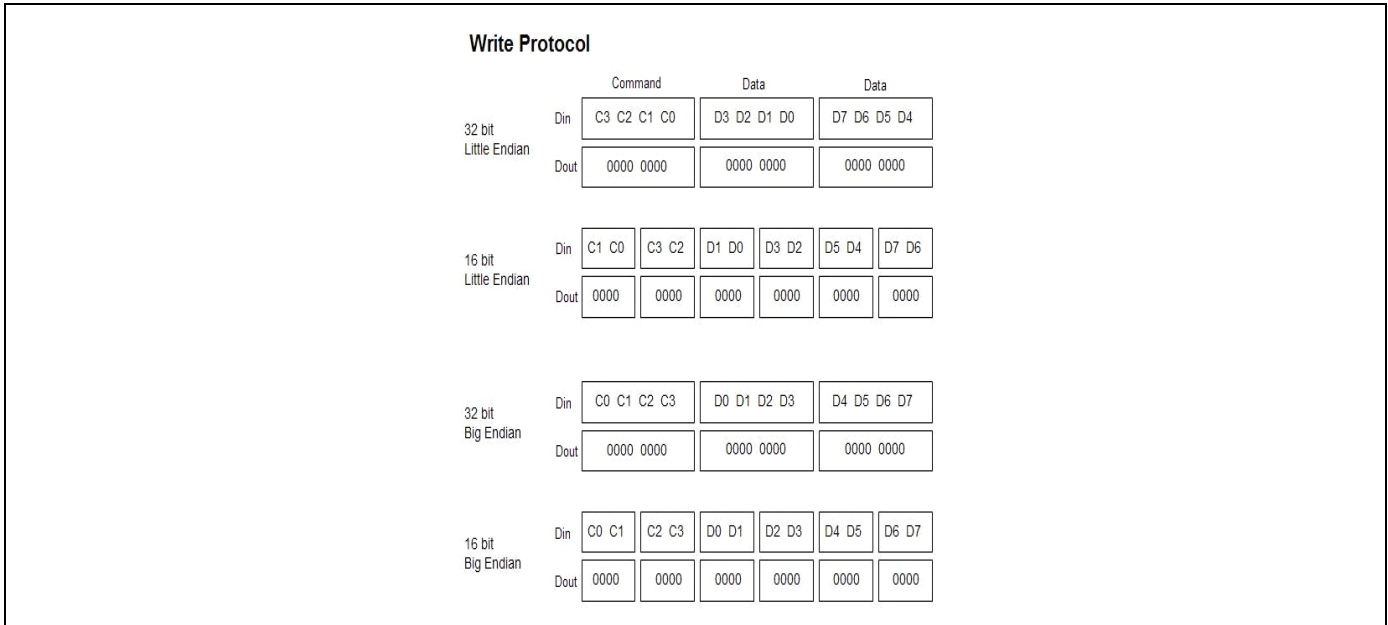
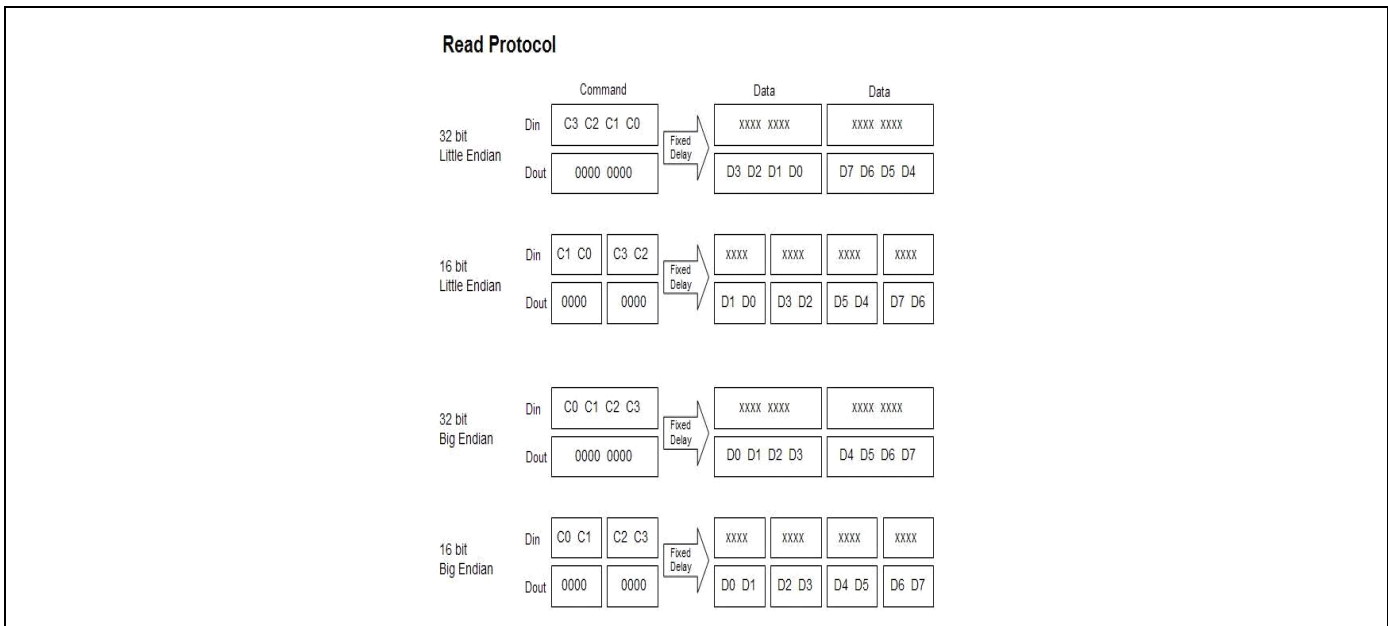

Figure 21. gSPI Read Protocol



9.2.1.1. Command Structure

The gSPI command structure is 32 bits. The bit positions and definitions are as shown in Figure 22.

Figure 22. gSPI Command Structure

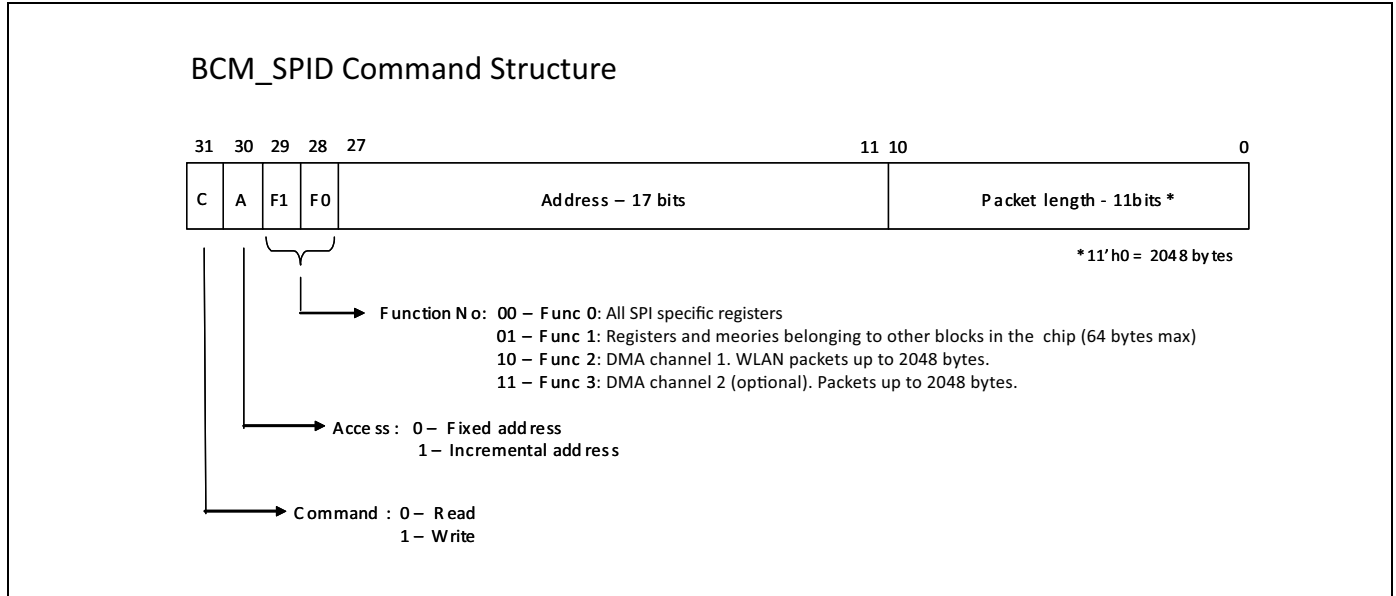

9.2.1.2. Write

The host puts the first bit of the data onto the bus half a clock-cycle before the first active edge following the CS going low. The following bits are clocked out on the falling edge of the gSPI clock. The device samples the data on the active edge.

9.2.1.3. Write/Read

The host reads on the rising edge of the clock requiring data from the device to be made available before the first rising clock edge of the clock burst for the data. The last clock edge of the fixed delay word can be used to represent the first bit of the following data word. This allows data to be ready for the first clock edge without relying on asynchronous delays.

9.2.1.4. Read

The read command always follows a separate write to set up the WLAN device for a read. This command differs from the write/read command in the following respects: a) chip selects go high between the command/address and the data and b) the time interval between the command/address is not fixed.

9.2.1.5. Status

The gSPI interface supports status notification to the host after a read/write transaction. This status notification provides information about any packet errors, protocol errors, information about available packet in the RX queue, etc. The status information helps in reducing the number of interrupts to the host. The status-reporting feature can be switched off using a register bit, without any timing overhead. The gSPI bus timing for read/write transactions with and without status notification are as shown in Figure 23 and Figure 24. See Table 13 for information on status field details.

Figure 23. gSPI Signal Timing Without Status (32-bit Big Endian)

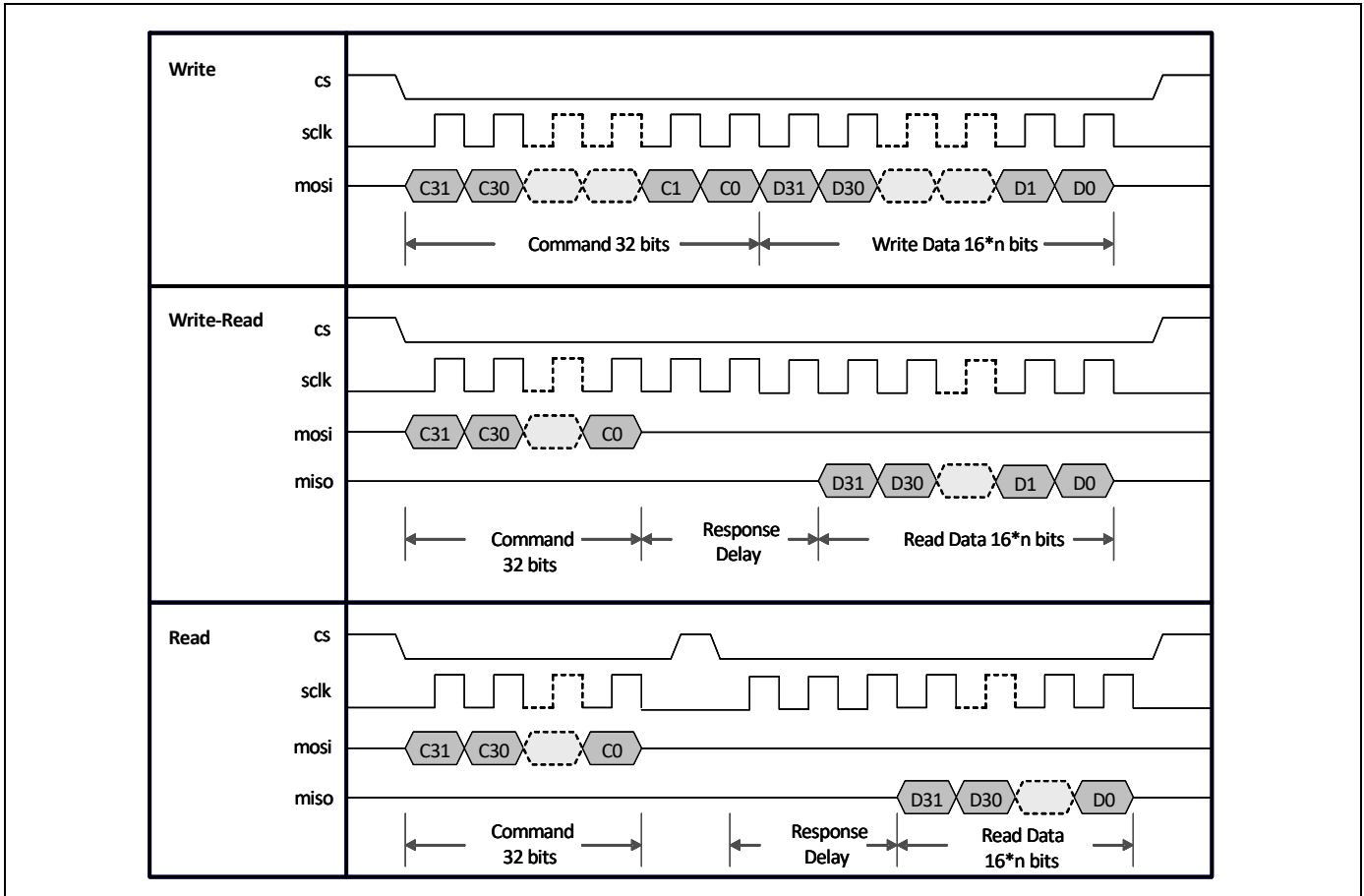

Figure 24. gSPI Signal Timing with Status (Response Delay = 0; 32-bit Big Endian)

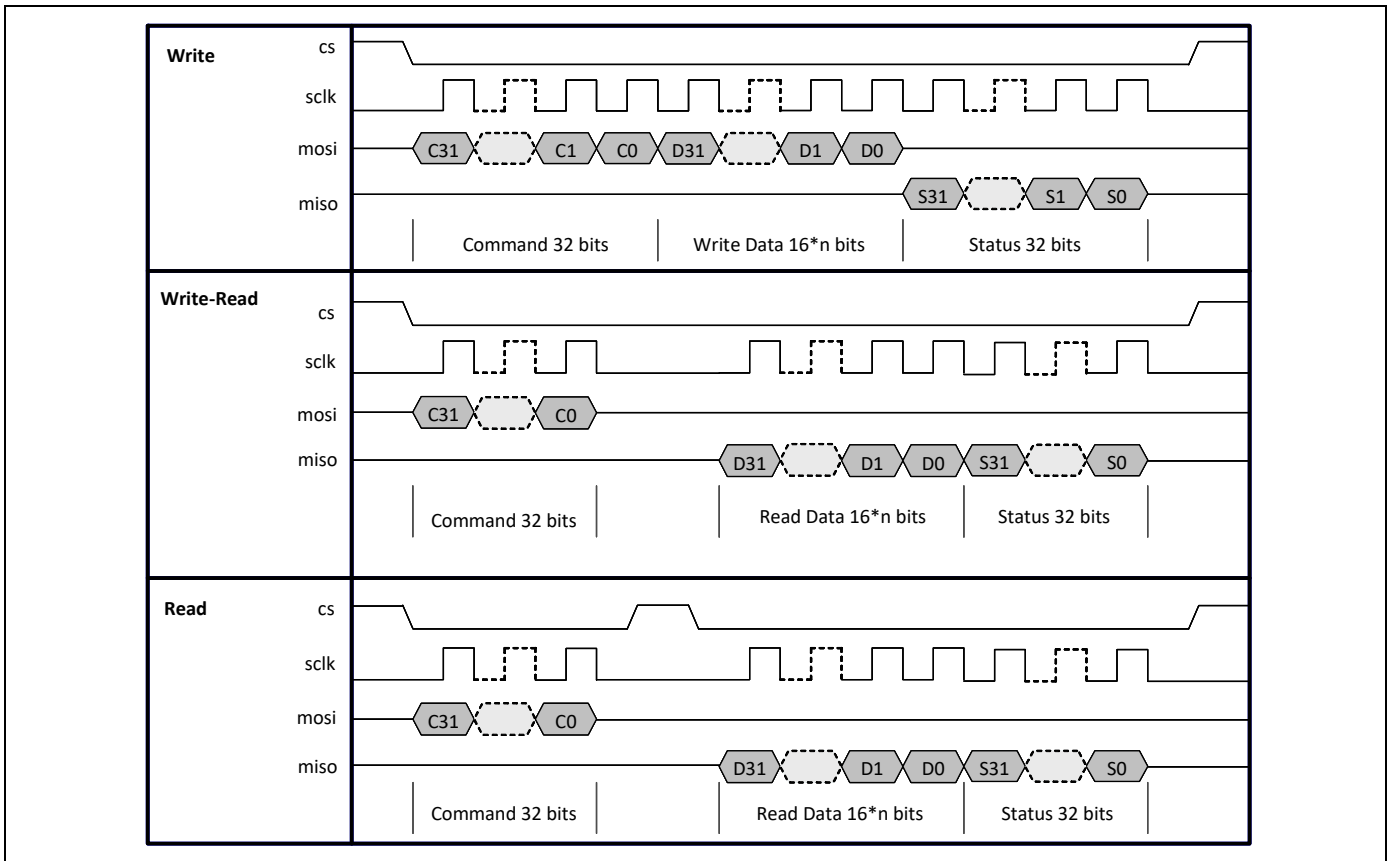

Table 13. gSPI Status Field Details

Bit	Name	Description
0	Data not available	The requested read data is not available
1	Underflow	FIFO underflow occurred due to current (F2, F3) read command
2	Overflow	FIFO overflow occurred due to current (F1, F2, F3) write command
3	F2 interrupt	F2 channel interrupt
4	F3 interrupt	F3 channel interrupt
5	F2 RX Ready	F2 FIFO is ready to receive data (FIFO empty)
6	F3 RX Ready	F3 FIFO is ready to receive data (FIFO empty)
7	Reserved	-
8	F2 Packet Available	Packet is available/ready in F2 TX FIFO
9:19	F2 Packet Length	Length of packet available in F2 FIFO
20	F3 Packet Available	Packet is available/ready in F3 TX FIFO
21:31	F3 Packet Length	Length of packet available in F3 FIFO

9.2.2 gSPI Host-Device Handshake

To initiate communication through the gSPI after power-up, the host needs to bring up the WLAN/Chip by writing to the wake-up WLAN register bit. Writing a 1 to this bit will start up the necessary crystals and PLLs so that the CYW43353 is ready for data transfer. The device can signal an interrupt to the host indicating that the device is awake and ready. This procedure also needs to be followed for waking up the device in sleep mode. The device can interrupt the host using the WLAN IRQ line whenever it has any information to pass to the host. On getting an interrupt, the host needs to read the interrupt and/or status register to determine the cause of interrupt and then take necessary actions.

9.2.3 Boot-Up Sequence

After power-up, the gSPI host needs to wait 150 ms for the device to be out of reset. For this, the host needs to poll with a read command to F0 addr 0x14. Address 0x14 contains a predefined bit pattern. As soon as the host gets a response back with the correct register content, it implies that the device has powered up and is out of reset. After that, the host needs to set the wakeup-WLAN bit (F0 reg 0x00 bit 7). The wakeup-WLAN issues a clock request to the PMU.

For the first time after power-up, the host must wait for the availability of low power clock inside the device. Once that is available, the host must write to a PMU register to set the crystal frequency, which turns on the PLL. After the PLL is locked, the chipActive interrupt is issued to the host. This interrupt indicates the device awake/ready status. See Table 14 for information on gSPI registers.

In Table 14, the following notation is used for register access:

- R: Readable from host and CPU
- W: Writable from host
- U: Writable from CPU

Table 14. gSPI Registers

Address	Register	Bit	Access	Default	Description
x0000	Word length	0	R/W/U	0	0: 16 bit word length 1: 32 bit word length
	Endianness	1	R/W/U	0	0: Little Endian 1: Big Endian
	High-speed mode	4	R/W/U	1	0: Normal mode. RX and TX at different edges. 1: High speed mode. RX and TX on same edge (default).
	Interrupt polarity	5	R/W/U	1	0: Interrupt active polarity is low 1: Interrupt active polarity is high (default)
	Wake-up	7	R/W	0	A write of 1 will denote a wake-up command from the host to the device. This will be followed by an F2 Interrupt from the gSPI device to the host, indicating device awake status.
x0001	Response delay	7:0	R/W/U	8'h04	Configurable read response delay in multiples of 8 bits
x0002	Status enable	0	R/W	1	0: no status sent to host after read/write 1: status sent to host after read/write
	Interrupt with status	1	R/W	0	0: do not interrupt if status is sent 1: interrupt host even if status is sent
	Response delay for all	2	R/W	0	0: response delay applicable to F1 read only 1: response delay applicable to all function read
x0003	Reserved	-	-	-	-

Table 14. gSPI Registers (Cont.)

Address	Register	Bit	Access	Default	Description
x0004	Interrupt register	0	R/W	0	Requested data not available; Cleared by writing a 1 to this location
		1	R	0	F2/F3 FIFO underflow due to last read
		2	R	0	F2/F3 FIFO overflow due to last write
		5	R	0	F2 packet available
		6	R	0	F3 packet available
		7	R	0	F1 overflow due to last write
x0005	Interrupt register	5	R	0	F1 Interrupt
		6	R	0	F2 Interrupt
		7	R	0	F3 Interrupt
x0006–x0007	Interrupt enable register	15:0	R/W/U	16'hE0E7	Particular Interrupt is enabled if a corresponding bit is set
x0008–x000B	Status register	31:0	R	32'h0000	Same as status bit definitions
x000C–x000D	F1 info register	0	R	1	F1 enabled
		1	R	0	F1 ready for data transfer
		13:2	R/U	12'h40	F1 max packet size
x000E–x000F	F2 info register	0	R/U	1	F2 enabled
		1	R	0	F2 ready for data transfer
		15:2	R/U	14'h800	F2 max packet size
x0010–x0011	F3 info register	0	R/U	1	F3 enabled
		1	R	0	F3 ready for data transfer
		15:2	R/U	14'h800	F3 max packet size
x0014–x0017	Test–Read only register	31:0	R	32'hFEED BEAD	This register contains a predefined pattern, which the host can read and determine if the gSPI interface is working properly.
x0018–x001B	Test–R/W register	31:0	R/W/U	32'h00000 000	This is a dummy register where the host can write some pattern and read it back to determine if the gSPI interface is working properly.

Figure 25 shows the WLAN boot-up sequence from power-up to firmware download.

Figure 25. WLAN Boot-Up Sequence

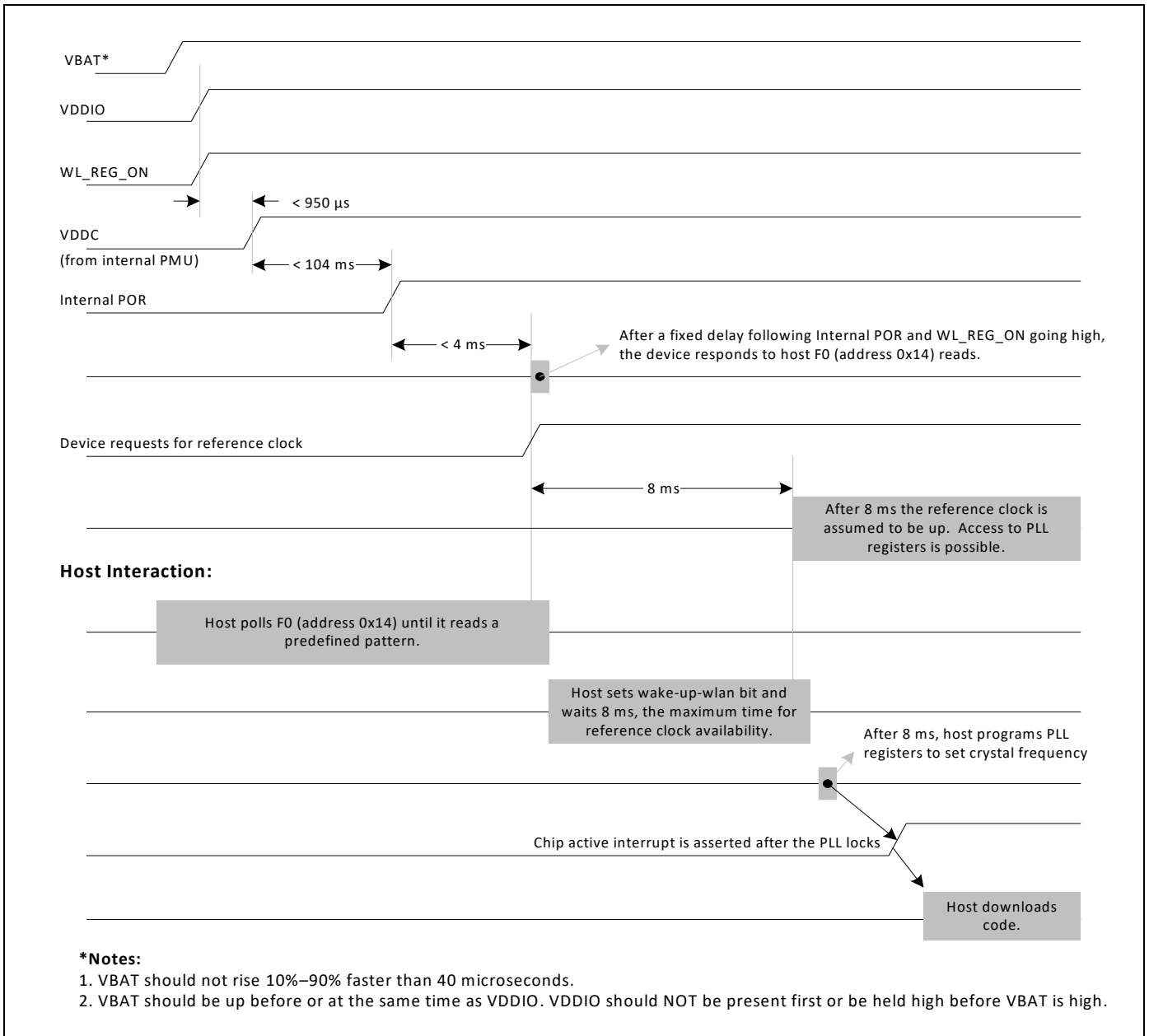

10. Wireless LAN MAC and PHY

10.1 IEEE 802.11ac MAC

The CYW43353 WLAN MAC is designed to support high-throughput operation with low-power consumption. It does so without compromising the Bluetooth coexistence policies, thereby enabling optimal performance over both networks. In addition, several power saving modes have been implemented that allow the MAC to consume very little power while maintaining network-wide timing synchronization. The architecture diagram of the MAC is shown in Figure 26.

The following sections provide an overview of the important modules in the MAC.

Figure 26. WLAN MAC Architecture

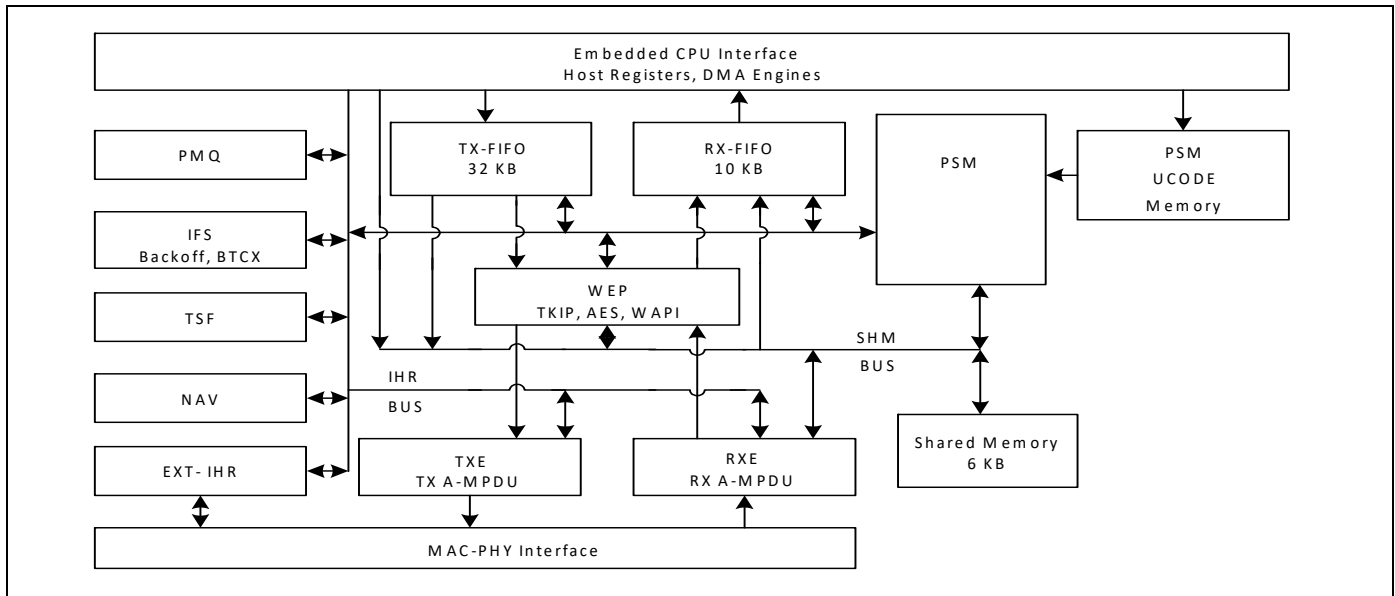

The CYW43353 WLAN media access controller (MAC) supports features specified in the IEEE 802.11 base standard, and amended by IEEE 802.11n. The key MAC features include:

- Enhanced MAC for supporting IEEE 802.11ac features
- Transmission and reception of aggregated MPDUs (A-MPDU) for high throughput (HT)
- Support for power management schemes, including WMM power-save, power-save multi-poll (PSMP) and multiphase PSMP operation
- Support for immediate ACK and Block-ACK policies
- Interframe space timing support, including RIFS
- Support for RTS/CTS and CTS-to-self frame sequences for protecting frame exchanges
- Back-off counters in hardware for supporting multiple priorities as specified in the WMM specification
- Timing synchronization function (TSF), network allocation vector (NAV) maintenance, and target beacon transmission time (TBTT) generation in hardware
- Hardware offload for AES-CCMP, legacy WPA TKIP, legacy WEP ciphers, WAPI, and support for key management
- Support for coexistence with Bluetooth and other external radios
- Programmable independent basic service set (IBSS) or infrastructure basic service set functionality

■ Statistics counters for MIB support

10.1.1 PSM

The programmable state machine (PSM) is a micro-coded engine, which provides most of the low-level control to the hardware, to implement the IEEE 802.11 specification. It is a microcontroller that is highly optimized for flow control operations, which are predominant in implementations of communication protocols. The instruction set and fundamental operations are simple and general, which allows algorithms to be optimized until very late in the design process. It also allows for changes to the algorithms to track evolving IEEE 802.11 specifications.

The PSM fetches instructions from the microcode memory. It uses the shared memory to obtain operands for instructions, as a data store, and to exchange data between both the host and the MAC data pipeline (via the SHM bus). The PSM also uses a scratch-pad memory (similar to a register bank) to store frequently accessed and temporary variables.

The PSM exercises fine-grained control over the hardware engines, by programming internal hardware registers (IHR). These IHRs are co-located with the hardware functions they control, and are accessed by the PSM via the IHR bus.

The PSM fetches instructions from the microcode memory using an address determined by the program counter, instruction literal, or a program stack. For ALU operations the operands are obtained from shared memory, scratch-pad, IHRs, or instruction literals, and the results are written into the shared memory, scratch-pad, or IHRs.

There are two basic branch instructions: conditional branches and ALU based branches. To better support the many decision points in the IEEE 802.11 algorithms, branches can depend on either a readily available signals from the hardware modules (branch condition signals are available to the PSM without polling the IHRs), or on the results of ALU operations.

10.1.2 WEP

The wired equivalent privacy (WEP) engine encapsulates all the hardware accelerators to perform the encryption and decryption, and MIC computation and verification. The accelerators implement the following cipher algorithms: legacy WEP, WPA TKIP, WPA2 AES-CCMP.

The PSM determines, based on the frame type and association information, the appropriate cipher algorithm to be used. It supplies the keys to the hardware engines from an on-chip key table. The WEP interfaces with the TXE to encrypt and compute the MIC on transmit frames, and the RXE to decrypt and verify the MIC on receive frames.

10.1.3 TXE

The transmit engine (TXE) constitutes the transmit data path of the MAC. It coordinates the DMA engines to store the transmit frames in the TXFIFO. It interfaces with WEP module to encrypt frames, and transfers the frames across the MAC-PHY interface at the appropriate time determined by the channel access mechanisms.

The data received from the DMA engines are stored in transmit FIFOs. The MAC supports multiple logical queues to support traffic streams that have different QoS priority requirements. The PSM uses the channel access information from the IFS module to schedule a queue from which the next frame is transmitted. Once the frame is scheduled, the TXE hardware transmits the frame based on a precise timing trigger received from the IFS module.

The TXE module also contains the hardware that allows the rapid assembly of MPDUs into an A-MPDU for transmission. The hardware module aggregates the encrypted MPDUs by adding appropriate headers and pad delimiters as needed.

10.1.4 RXE

The receive engine (RXE) constitutes the receive data path of the MAC. It interfaces with the DMA engine to drain the received frames from the RXFIFO. It transfers bytes across the MAC-PHY interface and interfaces with the WEP module to decrypt frames. The decrypted data is stored in the RXFIFO.

The RXE module contains programmable filters that are programmed by the PSM to accept or filter frames based on several criteria such as receiver address, BSSID, and certain frame types.

The RXE module also contains the hardware required to detect A-MPDUs, parse the headers of the containers, and disaggregate them into component MPDUS.

10.1.5 IFS

The IFS module contains the timers required to determine interframe space timing including RIFS timing. It also contains multiple backoff engines required to support prioritized access to the medium as specified by WMM.

The interframe spacing timers are triggered by the cessation of channel activity on the medium, as indicated by the PHY. These timers provide precise timing to the TXE to begin frame transmission. The TXE uses this information to send response frames or perform transmit frame-bursting (RIFS or SIFS separated, as within a TXOP).

The backoff engines (for each access category) monitor channel activity, in each slot duration, to determine whether to continue or pause the backoff counters. When the backoff counters reach 0, the TXE gets notified, so that it may commence frame transmission. In the event of multiple backoff counters decrementing to 0 at the same time, the hardware resolves the conflict based on policies provided by the PSM.

The IFS module also incorporates hardware that allows the MAC to enter a low-power state when operating under the IEEE power save mode. In this mode, the MAC is in a suspended state with its clock turned off. A sleep timer, whose count value is initialized by the PSM, runs on a slow clock and determines the duration over which the MAC remains in this suspended state. Once the timer expires the MAC is restored to its functional state. The PSM updates the TSF timer based on the sleep duration ensuring that the TSF is synchronized to the network.

The IFS module also contains the PTA hardware that assists the PSM in Bluetooth coexistence functions.

10.1.6 TSF

The timing synchronization function (TSF) module maintains the TSF timer of the MAC. It also maintains the target beacon transmission time (TBTT). The TSF timer hardware, under the control of the PSM, is capable of adopting timestamps received from beacon and probe response frames in order to maintain synchronization with the network.

The TSF module also generates trigger signals for events that are specified as offsets from the TSF timer, such as uplink and downlink transmission times used in PSMP.

10.1.7 NAV

The network allocation vector (NAV) timer module is responsible for maintaining the NAV information conveyed through the duration field of MAC frames. This ensures that the MAC complies with the protection mechanisms specified in the standard.

The hardware, under the control of the PSM, maintains the NAV timer and updates the timer appropriately based on received frames. This timing information is provided to the IFS module, which uses it as a virtual carrier-sense indication.

10.1.7.1. MAC-PHY Interface

The MAC-PHY interface consists of a data path interface to exchange RX/TX data from/to the PHY. In addition, there is a programming interface, which can be controlled either by the host or the PSM to configure and control the PHY.

10.2 IEEE 802.11ac PHY

The CYW43353 WLAN Digital PHY is designed to comply with IEEE 802.11ac and IEEE 802.11a/b/g/n single-stream specifications to provide wireless LAN connectivity supporting data rates from 1 Mbps to 433.3 Mbps for low-power, high-performance handheld applications.

The PHY has been designed to work in the presence of interference, radio nonlinearity, and various other impairments. It incorporates optimized implementations of the filters, FFT and Viterbi decoder algorithms. Efficient algorithms have been designed to achieve maximum throughput and reliability, including algorithms for carrier sense/rejection, frequency/phase/timing acquisition and tracking, channel estimation and tracking. The PHY receiver also contains a robust IEEE 802.11b demodulator. The PHY carrier sense has been tuned to provide high throughput for IEEE 802.11g/11b hybrid networks with Bluetooth coexistence. It has also been designed for shared single antenna systems between WL and BT to support simultaneous RX-RX.

The key PHY features include:

- Programmable data rates from MCS0–9 in 20 MHz, 40 MHz, and 80 MHz channels, as specified in IEEE 802.11ac
- Supports Optional Short GI mode in TX and RX
- Supports optional space-time block code (STBC) receive of two space-time streams for improved throughput and range in fading channel environments.
- All scrambling, encoding, forward error correction, and modulation in the transmit direction and inverse operations in the receive direction.
- Supports IEEE 802.11h/k for worldwide operation
- Advanced algorithms for low power, enhanced sensitivity, range, and reliability
- Algorithms to improve performance in presence of Bluetooth
- Automatic gain control scheme for blocking and non blocking application scenario for cellular applications
- Closed loop transmit power control
- Digital RF chip calibration algorithms to handle CMOS RF chip non-idealities
- On-the-fly channel frequency and transmit power selection
- Supports per packet RX antenna diversity
- Available per-packet channel quality and signal strength measurements
- Designed to meet FCC and other worldwide regulatory requirements

Figure 27. WLAN PHY Block Diagram

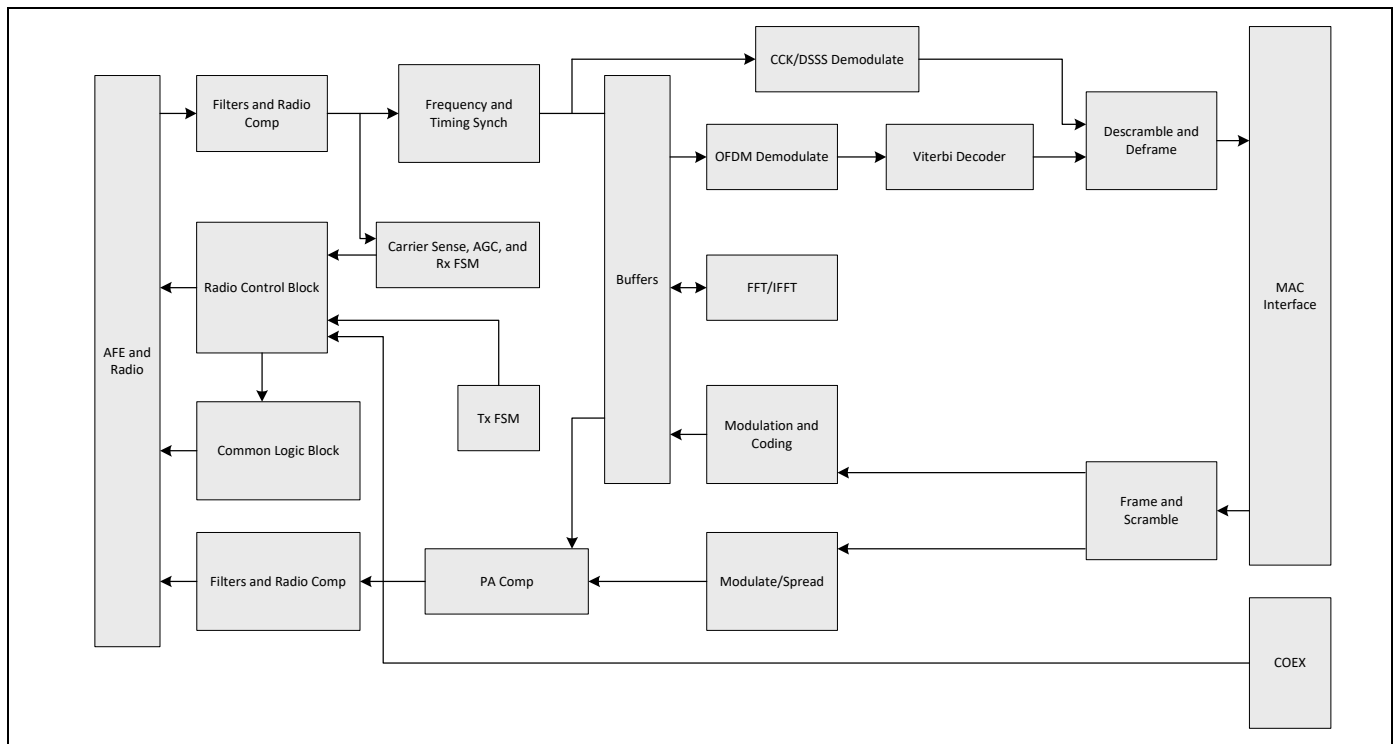

11. WLAN Radio Subsystem

The CYW43353 includes an integrated dual-band WLAN RF transceiver that has been optimized for use in 2.4 GHz and 5 GHz Wireless LAN systems. It has been designed to provide low-power, low-cost, and robust communications for applications operating in the globally available 2.4 GHz unlicensed ISM or 5 GHz U-NII bands. The transmit and receive sections include all on-chip filtering, mixing, and gain control functions.

Ten RF control signals are available to drive external RF switches and support optional external power amplifiers and low-noise amplifiers for each band. See the reference board schematics for further details.

A block diagram of the radio subsystem is shown in [Figure 28](#). Note that integrated on-chip baluns (not shown) convert the fully differential transmit and receive paths to single-ended signal pins.

11.1 Receiver Path

The CYW43353 has a wide dynamic range, direct conversion receiver that employs high order on-chip channel filtering to ensure reliable operation in the noisy 2.4 GHz ISM band or the entire 5 GHz U-NII band. An on-chip low-noise amplifier (LNA) in the 2.4 GHz path is shared between the Bluetooth and WLAN receivers, while the 5 GHz receive path has a dedicated on-chip LNA. Control signals are available that can support the use of optional LNAs for each band, which can increase the receive sensitivity by several dB.

11.2 Transmit Path

Baseband data is modulated and upconverted to the 2.4 GHz ISM or 5-GHz U-NII bands, respectively. Linear on-chip power amplifiers are included, which are capable of delivering high output powers while meeting IEEE 802.11ac and IEEE 802.11a/b/g/n specifications without the need for external PAs. When using the internal PAs, closed-loop output power control is completely integrated. As an option, external PAs can be used for even higher output power, in which case the closed-loop output power control is provided by means of a-band and g-band TSSI inputs from external power detectors.

11.3 Calibration

The CYW43353 features dynamic and automatic on-chip calibration to continually compensate for temperature and process variations across components. These calibration routines are performed periodically in the course of normal radio operation. Examples of some of the automatic calibration algorithms are baseband filter calibration for optimum transmit and receive performance, and LOFT calibration for carrier leakage reduction. In addition, I/Q Calibration, R Calibration, and VCO Calibration are performed on-chip. No per-board calibration is required in manufacturing test, which helps to minimize the test time and cost in large volume production.

Figure 28. Radio Functional Block Diagram

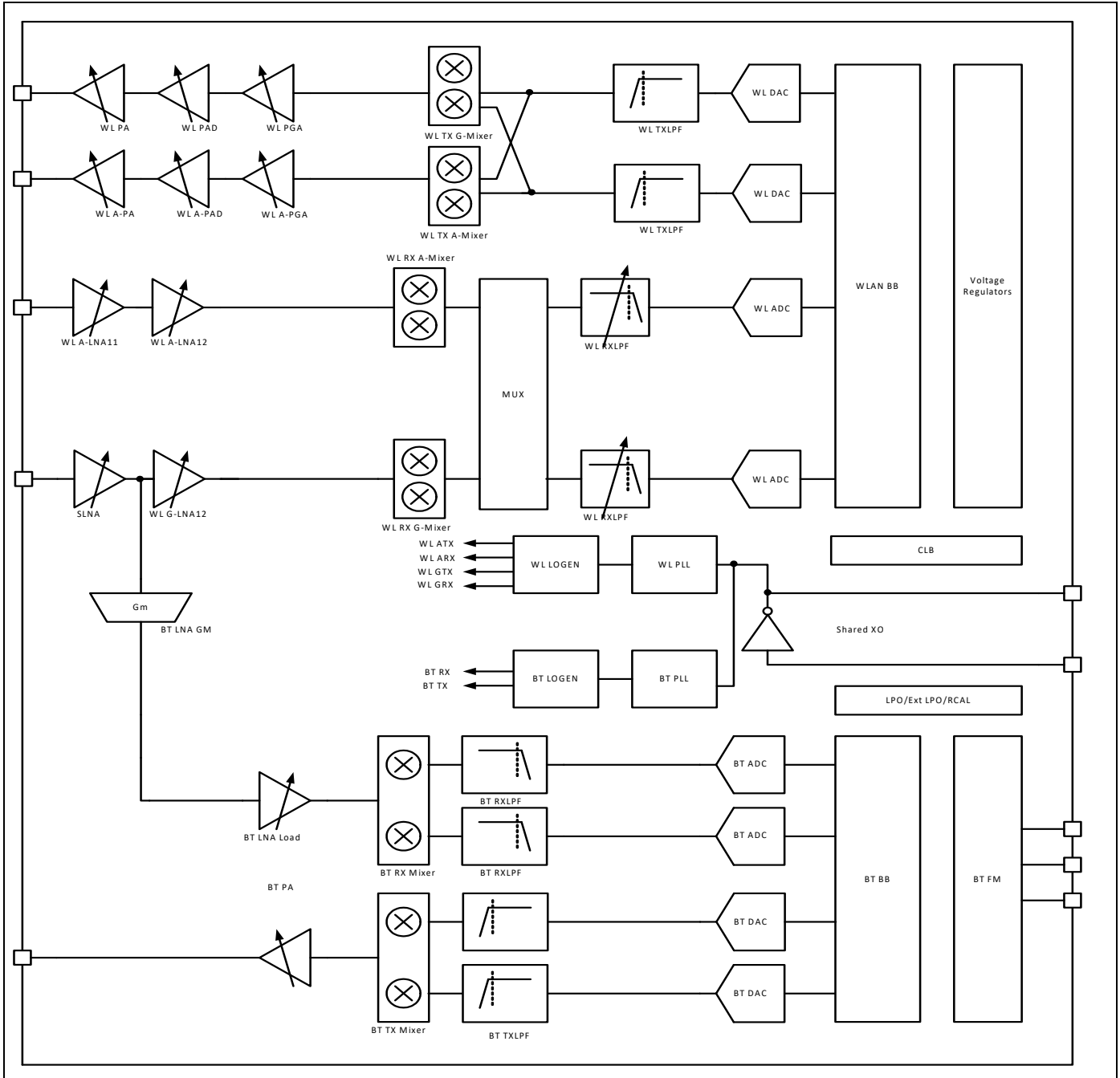

12.2 Signal Descriptions

The signal name, type, and description of each pin in the CYW43353 is listed in [Table 15](#). The symbols shown under Type indicate pin directions (I/O = bidirectional, I = input, O = output) and the internal pull-up/pull-down characteristics (PU = weak internal pull-up resistor and PD = weak internal pull-down resistor), if any.

Table 15. WLBGA Signal Descriptions

WLBGA Ball#	Signal Name	Type	Description
WLAN and Bluetooth RF Signal Interface			
N7	WRF_RFIN_2G	I	2.4 GHz Bluetooth and WLAN receiver shared input.
N5	BT_RF_TX	O	Bluetooth PA output.
N12	WRF_RFIN_5G	I	5 GHz WLAN receiver input.
N8	WRF_RFOUT_2G	O	2.4 GHz WLAN PA output.
N11	WRF_RFOUT_5G	O	5 GHz WLAN PA output.
J7	WRF_TSSI_A	I	5 GHz TSSI input from an optional external power amplifier/power detector.
H7	WRF_RES_EXT/ WRF_GPIO_OUT/WRF_TSSI_G	I/O	GPIO or 2.4 GHz TSSI input from an optional external power amplifier/power detector.
RF Switch Control Lines			
F12	RF_SW_CTRL_0	O	Programmable RF switch control lines. The control lines are programmable via the driver and NVRAM file.
F11	RF_SW_CTRL_1	O	
E12	RF_SW_CTRL_2	O	
E11	RF_SW_CTRL_3	O	
D12	RF_SW_CTRL_4	O	
F8	RF_SW_CTRL_5	O	
H9	RF_SW_CTRL_6	O	
G7	RF_SW_CTRL_7	O	
E10	RF_SW_CTRL_8	O	
F5	RF_SW_CTRL_9	O	
WLAN SDIO Bus Interface			
Note: These signals can also have alternate functionality depending on host interface mode. Refer to Table 21, "CYW43353 GPIO/SDIO Alternative Signal Functions," for additional details.			
B11	SDIO_CLK	I	SDIO clock input.
B12	SDIO_CMD	I/O	SDIO command line.
B10	SDIO_DATA_0	I/O	SDIO data line 0.
C10	SDIO_DATA_1	I/O	SDIO data line 1.
D10	SDIO_DATA_2	I/O	SDIO data line 2.
C11	SDIO_DATA_3	I/O	SDIO data line 3.

Table 15. WLBGA Signal Descriptions (Cont.)

WLBGA Ball#	Signal Name	Type	Description
WLAN GPIO Interface			
Note: The GPIO signals can be multiplexed via software and the JTAG_SEL pin to behave as various specific functions. See Table 21, "CYW43353 GPIO/SDIO Alternative Signal Functions," for additional details.			
B6	GPIO_0	I/O	Programmable GPIO pins. Note: These GPIO signals can be configured by software: as either inputs or outputs, to have internal pull-ups or pull-downs enabled or disabled, and to use either a high or low polarity upon assertion.
C6	GPIO_1	I/O	
D6	GPIO_2	I/O	
B5	GPIO_3	I/O	
C5	GPIO_4	I/O	
D5	GPIO_5	I/O	
C4	GPIO_6	I/O	
D4	GPIO_7	I/O	
H1	GPIO_8	I/O	
JTAG Interface			
E5	JTAG_SEL	I/O	JTAG select. Pull high to select the JTAG interface. If the JTAG interface is not used, this pin may be left floating or connected to ground. Note: See Table 21, "CYW43353 GPIO/SDIO Alternative Signal Functions," for the JTAG signal pins.
Clocks			
H12	WRF_XTAL_IN	I	XTAL oscillator input.
J12	WRF_XTAL_OUT	O	XTAL oscillator output.
B4	LPO_IN	I	External sleep clock input (32.768 kHz).
H3	CLK_REQ	O	Reference clock request (shared by BT and WLAN).
Bluetooth PCM			
G2	BT_PCM_CLK/BT_PCMCLK	I/O	PCM clock; can be master (output) or slave (input).
G1	BT_PCM_IN	I	PCM data input.
J3	BT_PCM_OUT	O	PCM data output.
H2	BT_PCM_SYNC	I/O	PCM sync; can be master (output) or slave (input).
Bluetooth UART			
E6	BT_UART_CTS_N/BT_UART_CTS	I	UART clear-to-send. Active-low clear-to-send signal for the HCI UART interface.
F6	BT_UART_RTS_N/ BT_UART_RTS/BT_LED	O	UART request-to-send. Active-low request-to-send signal for the HCI UART interface. BT LED control pin.
G6	BT_UART_RXD/BT_RFDisable2	I	UART serial input. Serial data input for the HCI UART interface. BT RF disable pin 2.
F7	BT_UART_TXD	O	UART serial output. Serial data output for the HCI UART interface.
Bluetooth/FM I2S			
J6	BT_I2S_CLK	I/O	I ² S clock, can be master (output) or slave (input).
K6	BT_I2S_DO	I/O	I ² S data output.
K5	BT_I2S_DI	I/O	I ² S data input.
H6	BT_I2S_WS	I/O	I ² S WS; can be master (output) or slave (input).

Table 15. WLBGA Signal Descriptions (Cont.)

WLBGA Ball#	Signal Name	Type	Description
Bluetooth GPIO			
M6	BT_AGPIO	I/O	BT analog GPIO pin.
Miscellaneous			
B3	WL_REG_ON	I	Used by PMU to power up or power down the internal CYW43353 regulators used by the WLAN section. Also, when deasserted, this pin holds the WLAN section in reset. This pin has an internal 200 kΩ pull-down resistor that is enabled by default. It can be disabled through programming.
D3	BT_REG_ON	I	Used by PMU to power up or power down the internal CYW43353 regulators used by the Bluetooth/FM section. Also, when deasserted, this pin holds the Bluetooth/FM section in reset. This pin has an internal 200 kΩ pull-down resistor that is enabled by default. It can be disabled through programming.
K3	BT_DEV_WAKE	I/O	Bluetooth DEV_WAKE.
J2	BT_HOST_WAKE	I/O	Bluetooth HOST_WAKE.
B8	HSIC_STROBE/STROBE	I/O	Unsupported. This pin can be connected to ground or left unconnected (no-connect).
B7	HSIC_DATA/DATA	I/O	Unsupported. This pin can be connected to ground or left unconnected (no-connect).
B9	RREFHSIC	I	Unsupported. Leave this pin unconnected (no-connect).
Integrated Voltage Regulators			
C2	SR_VDDBATA5V	I	Quiet VBAT.
C1	SR_VDDBATP5V	I	Power VBAT.
B2	SR_VLX	O	Cbuck switching regulator output. Refer to Table 37 for details of the inductor and capacitor required on this output.
D1	LDO_VDD1P5	I	LNLDO input.
F2	LDO_VDDBAT5V	I	LDO VBAT.
H11	WRF_XTAL_VDD1P5/ WRF_XTAL_BUCK_VDD1P5	I	XTAL LDO input (1.35V).
K12	WRF_XTAL_VDD1P2/ WRF_XTAL_OUT_VDD1P2	O	XTAL LDO output (1.2V).
E2	VOUT_LNLDO	O	Output of LNLDO.
D2	VOUT_CLDO	O	Output of core LDO.
F1	VOUT_BTLD02P5	O	Output of BT LDO.
E1	VOUT_3P3	O	LDO 3.3V output.
Bluetooth Supplies			
N6	BT_PAVDD/BT_PAVDD2P5	PWR	Bluetooth PA power supply.
N4	BT_LNAVDD/BT_LNAVDD1P2	PWR	Bluetooth LNA power supply.
L4	BT_IFVDD/BT_IFVDD1P2	PWR	Bluetooth IF block power supply.
M4	BT_PLLVDD/BT_PLLVDD1P2	PWR	Bluetooth RF PLL power supply.
N3	BT_VCOVDD/BT_VCOVDD1P2	PWR	Bluetooth RF power supply.
Supplies			
N1	LNF_VDD1P2	PWR	Connect to VOUT_LNLDO Output (pin E2).
L2	LNF_VDD1P2	PWR	Connect to VOUT_LNLDO Output (pin E2).
J1	LNF_VDD1P2	PWR	Connect to VOUT_LNLDO Output (pin E2).

Table 15. WLBGA Signal Descriptions (Cont.)

WLBGA Ball#	Signal Name	Type	Description
WLAN Supplies			
H8	WRF_WL_LNLDOIN_VDD1P5	PWR	LNLDO 1.35V supply.
K9	WRF_SYNTH_VBAT_VDD3P3	PWR	Synth VDD 3.3V supply.
L9	WRF_PADRV_VBAT_VDD3P3	PWR	PA Driver VBAT supply.
N10	WRF_PA5G_VBAT_VDD3P3	PWR	5 GHz PA 3.3V VBAT supply.
N9	WRF_PA2G_VBAT_VDD3P3	PWR	2 GHz PA 3.3V VBAT supply.
K10	WRF_MMD_VDD1P2	PWR	1.2V supply.
K11	WRF_PFD_VDD1P2	PWR	1.2V supply.
Miscellaneous Supplies			
C7, C12, G4, G5, G8	VDDC/WL_VDDC	PWR	1.2V core supply for WLAN.
F3	VDDIO /VDDIO2	PWR	1.8V–3.3V supply for WLAN. Must be directly connected to PMU_VDDIO and BT_VDDIO on the PCB.
H5, J4	BT_VDDC	PWR	1.2V core supply for BT.
H4	BT_VDDIO	PWR	1.8V–3.3V supply for BT. Must be directly connected to PMU_VDDIO and VDDIO on the PCB.
D9	VDDIO_SD	PWR	1.8V–3.3V supply for SDIO pads.
E7	VDDIO_RF	PWR	IO supply for RF switch control pads (3.3V).
C8	AVDD12PLL/HSIC_AVDD12PLL	PWR	HSIC is not supported. Connect this pin to ground to minimize leakage.
C9	DVDD12HSIC/HSIC_DVDD12	PWR	HSIC is not supported. Connect this pin to ground to minimize leakage.
G12	BBPLL_AVDD1P2	PWR	1.2V supply for baseband PLL.
Ground			
H10	WRF_VCO_GND1P2/ WRF_VCO_GND	GND	VCO/LOGEN ground.
K7	WRF_AFE_GND1P2	GND	AFE ground.
J8	WRF_BUCK_GND1P5	GND	Internal capacitor-less LDO ground.
M7	WRF_LNA_2G_GND1P2	GND	2 GHz internal LNA ground.
M12	WRF_LNA_5G_GND1P2	GND	5 GHz internal LNA ground.
L8	WRF_TX_GND1P2	GND	TX ground.
L10	WRF_PADRV_VBAT_GND3P3	GND	PAD ground.
G11	WRF_XTAL_GND1P2	GND	XTAL ground.
L7	WRF_RX2G_GND1P2	GND	RX 2GHz ground.
L12	WRF_RX5G_GND1P2	GND	RX 5GHz ground.
L11	WRF_LO_GND1P2_1	GND	LO ground.
K8	WRF_LO_GND1P2_2	GND	LO ground.
M11	WRF_PA_VBAT_GND3P3_1	GND	PA ground.
M10	WRF_PA_VBAT_GND3P3_2	GND	PA ground.
M9	WRF_PA_VBAT_GND3P3_3	GND	PA ground.
M8	WRF_PA_VBAT_GND3P3_4	GND	PA ground.
J9	WRF_MMD_GND1P2	GND	Ground.
J11	WRF_CP_GND1P2/ WRF_CP_GND	GND	Ground.
J10	WRF_PFD_GND1P2	GND	Ground.
D7, D11, E3, E8, J5, K4	VSSC	GND	Core ground for WLAN and BT.
B1	SR_PVSS	GND	Power ground.

Table 15. WLBGA Signal Descriptions (Cont.)

WLBGA Ball#	Signal Name	Type	Description
C3	PMU_AVSS	GND	Quiet ground.
D8	AGND12PLL/HSIC_AGNDPLL	GND	PLL ground.
M5	BT_PAVSS	GND	Bluetooth PA ground.
L6	BT_IFVSS	GND	Bluetooth IF block ground.
L5	BT_PLLVSS	GND	Bluetooth PLL ground.
M3	BT_VCOVSS	GND	Bluetooth VCO ground.
M1	VSSF	GND	Ground.
M2	VSSF	GND	Ground.
L3	VSSF	GND	Ground.
K2	VSSF	GND	Ground.
G10	AVSS_BBPLL/BBPLLAVSS	GND	Baseband PLL ground.
No Connect			
A2, A3, A4, A6, A7, A9, A10, A11	NC	-	No connect

12.3 WLAN GPIO Signals and Strapping Options

The pins listed in [Table 16](#) are sampled at power-on reset (POR) to determine the various operating modes. Sampling occurs a few milliseconds after an internal POR or deassertion of the external POR. After the POR, each pin assumes the GPIO or alternative function specified in the signal descriptions table. Each strapping option pin has an internal pull-up (PU) or pull-down (PD) resistor that determines the default mode. To change the mode, connect an external PU resistor to VDDIO or a PD resistor to GND, using a 10 kΩ resistor or less.

Note: Refer to the reference board schematics for more information.

Table 16. WLAN GPIO Functions and Strapping Options

Pin Name	WLBGAPin #	Default Function	Description
GPIO_7	D4	1	SDIO_SEL ¹
GPIO_8	H1	0	SDIO_PADVDDIO
SDIO_CLK	B11	1	CPU-LESS ¹
SDIO_DATA_2	D10	1	SPI_SEL ¹

1. See [Table 17](#) and [Table 18](#).

Table 17. SDIO/gSPI I/O Voltage Selection

SDIO_SEL	SPI_SEL	SDIO_PADVDDIO	Mode
1	X	0	1.8V I/O
1	X	1	3.3V I/O
0	1	0	1.8V I/O
0	1	1	3.3V I/O
0	0	X	3.3V I/O

Table 18. Host Interface Selection (WLBGA Package)

SDIO_SEL	SPI_SEL	CPULESS	Mode
1	X	X	SDIO Mode (3.3V or 1.8V I/O)
0	1	X	gSPI Mode (3.3V or 1.8V I/O)
0	0	0	Unsupported
0	0	1	Unsupported

12.3.1 Multiplexed Bluetooth GPIO Signals

The Bluetooth GPIO pins (BT_GPIO_0 to BT_GPIO_7) are multiplexed pins and can be programmed to be used as GPIOs or for other Bluetooth[®] I²S. The specific function for a given BT_GPIO_X pin is chosen by programming the Pad Function Control register for that specific pin. Table 19 for each BT_GPIO_X pin. Note that each BT_GPIO_X pin's Pad Function Control register setting is independent (BT_GPIO_1 can be set to I²S, BT_GPIO_3 is set to pad function 0). When the Pad Function Control register is set to 0, the BT_GPIOs do not have specific functions generic GPIOs. The A_GPIO_X pins described below are multiplexed behind the CYW43353's PCM and I²S interface pins.

Table 19. GPIO Multiplexing Matrix

Pin Name	Pad Function Control Register Setting						
	0	1	2	3	4	5	6
BT_UART_CTS_N	UART_CTS_N	-	-	-	-	-	-
BT_UART_RTS_N	UART_RTS_N	-	-	-	-	-	-
BT_UART_RXD	UART_RXD	-	-	-	-	-	-
BT_UART_TXD	UART_TXD	-	-	-	-	-	-
BT_PCM_IN	A_GPIO[3]	PCM_IN	PCM_IN	HCLK	-	-	I ² S
BT_PCM_OUT	A_GPIO[2]	PCM_OUT	PCM_OUT	LINK_IND	-	I2S_MSDO	-
BT_PCM_SYNC	A_GPIO[1]	PCM_SYNC	PCM_SYNC	HCLK	INT_LPO	I2S_MWS	-
BT_PCM_CLK	A_GPIO[0]	PCM_CLK	PCM_CLK	-	-	I2S_MSCK	-
BT_I2S_DO	A_GPIO[5]	PCM_OUT	-	-	I2S_SSDO	I2S_MSDO	-
BT_I2S_DI	A_GPIO[6]	PCM_IN	-	HCLK	I2S_SSDI/MSDI	-	-
BT_I2S_WS	GPIO[7]	PCM_SYNC	-	LINK_IND	-	I2S_MWS	-
BT_I2S_CLK	GPIO[6]	PCM_CLK	-	-	INT_LPO	I2S_MSCK	-
BT_GPIO_1	GPIO[1]	-	-	-	-	-	-
BT_GPIO_0	GPIO[0]	-	-	-	clk_12p288	-	-
CLK_REQ	WL/BT_CLK_REQ	-	-	-	-	-	-

The multiplexed GPIO signals are described in Table 20.

Table 20. Multiplexed GPIO Signals

Pin Name	Type	Description
UART_CTS_N	I	Host UART clear to send.
UART_RTS_N	O	Device UART request to send.
UART_RXD	I	Device UART receive data.
UART_TXD	O	Host UART transmit data.
PCM_IN	I	PCM data input.
PCM_OUT	O	PCM data output.
PCM_SYNC	I/O	PCM sync signal, can be master (output) or slave (input).
PCM_CLK	I/O	PCM clock, can be master (output) or slave (input).
GPIO[7:0]	I/O	General-purpose I/O.
A_GPIO[7:0]	I/O	A group general-purpose I/O.
I2S_MSDO	O	I ² S master data output.
I2S_MWS	O	I ² S master word select.
I2S_MSCK	O	I ² S master clock.
I2S_SSCK	I	I ² S slave clock.
I2S_SSDO	O	I ² S slave data output.
I2S_SWS	I	I ² S slave word select.
I2S_SSDI/MSDI	I	I ² S slave/master data input.
STATUS	O	Signals Bluetooth priority status.
TX_CON_FX	I	WLAN-BT coexist. Transmission confirmation; permission for BT to transmit.
RF_ACTIVE	O	WLAN-BT coexist. Asserted (logic high) during local BT RX and TX slots.
LINK_IND	O	BT receiver/transmitter link indicator.
CLK_REQ	O	WLAN/BT clock request output.
SF_SPI_CLK	O	SFlash SCLK: serial clock (output from master).
SF_MISO	I	SFlash MISO; SOMI: master input, slave output (output from slave).
SF_MOSI	O	SFlash MOSI; SIMO: master output, slave input (output from master).
SF_SPI_CSN	O	SFlash SS: slave select (active low, output from master).

12.4 GPIO/SDIO Alternative Signal Functions

Table 21. CYW43353 GPIO/SDIO Alternative Signal Functions ^{1 2}

Pins	WLBGA SDIO
GPIO_0	WL_HOST_WAKE
GPIO_1	WL_DEV_WAKE
GPIO_2	TCK, GCI_GPIO_1, or UART RX
GPIO_3	TMS or GCI_GPIO_0
GPIO_4	TDI or SECI_IN
GPIO_5	TDO or SECI_OUT
GPIO_6	TRST_L or UART TX
GPIO_7	[Strap, tied High]
GPIO_8	[Strap, tied High or Low]
GPIO_9	N/A
GPIO_10	N/A
GPIO_11	N/A
GPIO_12	N/A
GPIO_13	N/A
GPIO_14	N/A
GPIO_15	N/A
SDIO_CLK	SDIO_CLK
SDIO_CMD	SDIO_CMD
SDIO_DATA_0	SDIO_DATA_0
SDIO_DATA_1	SDIO_DATA_1
SDIO_DATA_2	SDIO_DATA_2
SDIO_DATA_3	SDIO_DATA_3

1. N/A = Pin not available in this package.

2. JTAG signals (TCK, TDI, TDO, TMS, and TRST_L) are selected when JTAG_SEL pin is high.

12.5 I/O States

The following notations are used in Table 22:

- I: Input signal
- O: Output signal
- I/O: Input/Output signal
- PU = Pulled up
- PD = Pulled down
- NoPull = Neither pulled up nor pulled down

Table 22. I/O States

Name	I/O	Keeper ¹	Active Mode	Low Power State/Sleep (All Power Present)	Power-down ² (BT_REG_ON and WL_REG_ON Held Low)	Out-of-Reset; Before SW Download (BT_REG_ON High; WL_REG_ON High)	(WL and E and 0) and Pres
WL_REG_ON	I	N	Input; PD (pull-down can be disabled)	Input; PD (pull-down can be disabled)	Input; PD (of 200K)	Input; PD (of 200K)	Input;
BT_REG_ON	I	N	Input; PD (pull down can be disabled)	Input; PD (pull down can be disabled)	Input; PD (of 200K)	Input; PD (of 200K)	Input;
CLK_REQ	I/O	Y	Open drain or push-pull (programmable), Active high.	Open drain or push-pull (programmable), Active high	PD	Open drain, Active high	Open
BT_HOST_WAKE	I/O	Y	Input/Output; PU, PD, NoPull (programmable)	Input/Output; PU, PD, NoPull (programmable)	High-Z, NoPull	Input, PU	Input;
BT_DEV_WAKE	I/O	Y	Input/Output; PU, PD, NoPull (programmable)	Input; PU, PD, NoPull (programmable)	High-Z, NoPull	Input, PD	Input;
BT_GPIO 2, 3, 4, 5	I/O	Y	Input/Output; PU, PD, NoPull (programmable)	Input/Output; PU, PD, NoPull (programmable)	High-Z, NoPull	Input, PD	Input;
BT_UART_CTS	I	Y	Input; NoPull	Input; NoPull	High-Z, NoPull	Input; PU	Input;
BT_UART_RTS	O	Y	Output; NoPull	Output; NoPull	High-Z, NoPull	Input; PU	Input;
BT_UART_RXD	I	Y	Input; PU	Input; NoPull	High-Z, NoPull	Input; PU	Input;
BT_UART_TXD	O	Y	Output; NoPull	Output; NoPull	High-Z, NoPull	Input; PU	Input;
SDIO Data	I/O	N	Input/Output; PU (SDIO Mode)	Input; PU (SDIO Mode)	High-Z, NoPull	Input; PU (SDIO Mode)	Input;
SDIO CMD	I/O	N	Input/Output; PU (SDIO Mode)	Input; PU (SDIO Mode)	High-Z, NoPull	Input; PU (SDIO Mode)	Input;
SDIO_CLK	I	N	Input; NoPull	Input; noPull	High-Z, NoPull	Input; noPull	Input;
BT_PCM_CLK	I/O	Y	Input; NoPull ³	Input; NoPull ³	High-Z, NoPull	Output	Input;

Table 22. I/O States (Cont.)

Name	I/O	Keeper 1	Active Mode	Low Power State/Sleep (All Power Present)	Power-down ² (BT_REG_ON and WL_REG_ON Held Low)	Out-of-Reset; Before SW Download (BT_REG_ON High; WL_REG_ON High)	(WL and E 0) an Pres
BT_PCM_IN	I/O	Y	Input; NoPull ³	Input; NoPull ³	High-Z, NoPull	Input; NoPull, Hi-Z	Input;
BT_PCM_OUT	I/O	Y	Input; NoPull ³	Input; NoPull ³	High-Z, NoPull	Output	Input;
BT_PCM_SYNC	I/O	Y	Input; NoPull ³	Input; NoPull ³	High-Z, NoPull	Output	Input;
BT_I2S_WS	I/O	Y	PD ⁴	PD ⁴	High-Z, NoPull	Input, PD	Input;
BT_I2S_CLK	I/O	Y	PD ⁴	PD ⁴	High-Z, NoPull	Input, PD	Input;
BT_I2S_DI	I/O	Y	PD ⁴	Input; PD ⁴	High-Z, NoPull	Input, PD	Input;
BT_I2S_DO	I/O	Y	Output ⁴	Output ⁴	High-Z, NoPull	Input, PD	Input;
WL GPIO_0	I/O	Y	Input/Output; PU, PD, NoPull (programmable [Default: PD])	Input/Output; PU, PD, NoPull (programmable [Default: PD])	High-Z, NoPull	Input; PD	Input;
WL GPIO_1	I/O	Y	Input/Output; PU, PD, NoPull (programmable [Default: NoPull])	Input/Output; PU, PD, NoPull (programmable [Default: NoPull])	High-Z, NoPull	Input; NoPull	Input;
WL GPIO_2	I/O	Y	Input/Output; PU, PD, NoPull (programmable [Default: NoPull])	Input/Output; PU, PD, NoPull (programmable [Default: NoPull])	High-Z, NoPull	Input; NoPull	Input;
WL GPIO_3	I/O	Y	Input/Output; PU, PD, NoPull (programmable [Default: PD])	Input/Output; PU, PD, NoPull (programmable [Default: PD])	High-Z, NoPull	Input; PD	Input;
WL GPIO_4	I/O	Y	Input/Output; PU, PD, NoPull (programmable [Default: NoPull])	Input/Output; PU, PD, NoPull (programmable [Default: NoPull])	High-Z, NoPull	Input; NoPull	Input;
WL GPIO_5	I/O	Y	Input/Output; PU, PD, NoPull (programmable [Default: PD])	Input/Output; PU, PD, NoPull (programmable [Default: PD])	High-Z, NoPull	Input; PD	Input;
WL GPIO_6	I/O	Y	Input/Output; PU, PD, NoPull (programmable [Default: NoPull])	Input/Output; PU, PD, NoPull (programmable [Default: NoPull])	High-Z, NoPull	Input; NoPull	Input;
WL GPIO_7	I/O	Y	Input/Output; PU, PD, NoPull (programmable [Default: NoPull])	Input/Output; PU, PD, NoPull (programmable [Default: NoPull])	High-Z, NoPull	Input; NoPull	Input;
WL GPIO_8	I/O	Y	Input/Output; PU, PD, NoPull (programmable [Default: PD]) ⁵	Input/Output; PU, PD, NoPull (programmable [Default: PD]) ⁵	High-Z, NoPull	Input; PD ⁵	Input;
RF_SW_CTRL_X	O	N	Output, NoPull	Output, NoPull	High-Z, NoPull	Output, NoPull	Output

1. Keeper column: N = pad has no keeper. Y = pad has a keeper. Keeper is always active except in Power-down state. If there is no keeper, and it is an input and there is Nopull, then the pad should be driven to prevent leakage due to floating pad (SDIO_CLK, for example).
2. In the Power-down state (xx_REG_ON=0): High-Z; NoPull => the pad is disabled because power is not supplied.
3. Depending on whether the PCM interface is enabled and the configuration of PCM is in master or slave mode, it can be either output or input.
4. Depending on whether the I²S interface is enabled and the configuration of I²S is in master or slave mode, it can be either output or input
5. NoPull when in SDIO mode.

13. DC Characteristics

13.1 Absolute Maximum Ratings

Caution! The absolute maximum ratings in [Table 23](#) indicate levels where permanent damage to the device can occur, even if these limits are exceeded for only a brief duration. Functional operation is not guaranteed under these conditions. Operation at absolute maximum conditions for extended periods can adversely affect long-term reliability of the device.

Table 23. Absolute Maximum Ratings

Rating	Symbol	Value	Unit
DC supply for VBAT and PA driver supply ¹	VBAT	-0.5 to +6.0	V
DC supply voltage for digital I/O	VDDIO	-0.5 to 3.9	V
DC supply voltage for RF switch I/Os	VDDIO_RF	-0.5 to 3.9	V
DC input supply voltage for CLDO and LNLDO	-	-0.5 to 1.575	V
DC supply voltage for RF analog	VDD1P2	-0.5 to 1.32	V
DC supply voltage for core	VDDC	-0.5 to 1.32	V
WRF_TCXO_VDD	-	-0.5 to 3.63	V
Maximum undershoot voltage for I/O ²	V _{undershoot}	-0.5	V
Maximum overshoot voltage for I/O ^b	V _{overshoot}	VDDIO + 0.5	V
Maximum junction temperature	T _j	125	°C

1. The maximum continuous voltage is 4.8V. Voltage transients up to 6.0V (for up to 10 seconds), cumulative duration over the lifetime of the device, are allowed. Voltage transients as high as 5.0V (for up to 250 seconds), cumulative duration over the lifetime of the device, are allowed.

2. Duration not to exceed 25% of the duty cycle.

13.2 Environmental Ratings

The environmental ratings are shown in [Table 24](#).

Table 24. Environmental Ratings

Characteristic	Value	Units	Conditions/Comments
Ambient Temperature (T _A)	-40 to +85	°C	Functional operation ¹
Storage Temperature	-40 to +125	°C	-
Relative Humidity	Less than 60	%	Storage
	Less than 85	%	Operation

1. Functionality is guaranteed but specifications require derating at extreme temperatures; see the specification tables for details.

13.3 Electrostatic Discharge Specifications

Extreme caution must be exercised to prevent electrostatic discharge (ESD) damage. Proper use of wrist and heel grounding straps to discharge static electricity is required when handling these devices. Always store unused material in its antistatic packaging.

Table 25. ESD Specifications

Pin Type	Symbol	Condition	ESD Rating	Unit
ESD, Handling Reference: NQY00083, Section 3.4, Group D9, Table B	ESD_HAND_HBM	Human body model contact discharge per JEDEC EID/JESD22-A114	±1000	V
CDM	ESD_HAND_CDM	Charged device model contact discharge per JEDEC EIA/JESD22-C101	±300	V

13.4 Recommended Operating Conditions and DC Characteristics

Caution! Functional operation is not guaranteed outside of the limits shown in Table 26 and operation outside these limits for extended periods can adversely affect long-term reliability of the device.

Table 26. Recommended Operating Conditions and DC Characteristics

Parameter	Symbol	Value			Unit
		Minimum	Typical	Maximum	
DC supply voltage for VBAT	VBAT	3.0 ¹	–	4.8 ²	V
DC supply voltage for core	VDD	1.14	1.2	1.26	V
DC supply voltage for RF blocks in chip	VDD1P2	1.14	1.2	1.26	V
DC supply voltage for TCXO input buffer	WRF_TCXO_VDD	1.62	1.8	1.98	V
DC supply voltage for digital I/O	VDDIO, VDDIO_SD	1.71	–	3.63	V
DC supply voltage for RF switch I/Os	VDDIO_RF	3.13	3.3	3.46	V
External TSSI input	WRF_TSSI_A, WRF_TSSI_G	0.15	–	0.95	V
Internal POR threshold	Vth_POR	0.4	–	0.7	V
SDIO Interface I/O Pins					
For VDDIO_SD = 1.8V:					
Input high voltage	VIH	1.27	–	–	V
Input low voltage	VIL	–	–	0.58	V
Output high voltage @ 2 mA	VOH	1.40	–	–	V
Output low voltage @ 2 mA	VOL	–	–	0.45	V
For VDDIO_SD = 3.3V:					
Input high voltage	VIH	0.625 × VDDIO	–	–	V
Input low voltage	VIL	–	–	0.25 × VDDIO	V
Output high voltage @ 2 mA	VOH	0.75 × VDDIO	–	–	V
Output low voltage @ 2 mA	VOL	–	–	0.125 × VDDIO	V
Other Digital I/O Pins					
For VDDIO = 1.8V:					
Input high voltage	VIH	0.65 × VDDIO	–	–	V
Input low voltage	VIL	–	–	0.35 × VDDIO	V
Output high voltage @ 2 mA	VOH	VDDIO – 0.45	–	–	V

Table 26. Recommended Operating Conditions and DC Characteristics (Cont.)

Parameter	Symbol	Value			Unit
		Minimum	Typical	Maximum	
Output low voltage @ 2 mA	VOL	–	–	0.45	V
For VDDIO = 3.3V:					
Input high voltage	VIH	2.00	–	–	V
Input low voltage	VIL	–	–	0.80	V
Output high voltage @ 2 mA	VOH	VDDIO – 0.4	–	–	V
Output low Voltage @ 2 mA	VOL	–	–	0.40	V
RF Switch Control Output Pins³					
For VDDIO_RF = 3.3V:					
Output high voltage @ 2 mA	VOH	VDDIO – 0.4	–	–	V
Output low voltage @ 2 mA	VOL	–	–	0.40	V
Output capacitance	C _{OUT}	–	–	5	pF

1. The CYW43353 is functional across this range of voltages. Optimal RF performance specified in the data sheet, however, is guaranteed only for 3.13V < VBAT < 4.8V.
2. The maximum continuous voltage is 4.8V. Voltage transients up to 6.0V (for up to 10 seconds), cumulative duration over the lifetime of the device are allowed. Voltage transients as high as 5.0V (for up to 250 seconds), cumulative duration over the lifetime of the device are allowed.
3. Programmable 2 mA to 16 mA drive strength. Default is 10 mA.

14. Bluetooth RF Specifications

Unless otherwise stated, limit values apply for the conditions specified in Table 24, “Environmental Ratings,” and Table 26, “Recommended Operating Conditions and DC Characteristics,”. Typical values apply for the following conditions:

- VBAT = 3.6V
- Ambient temperature +25°C

Figure 30. Port Locations for Bluetooth Testing

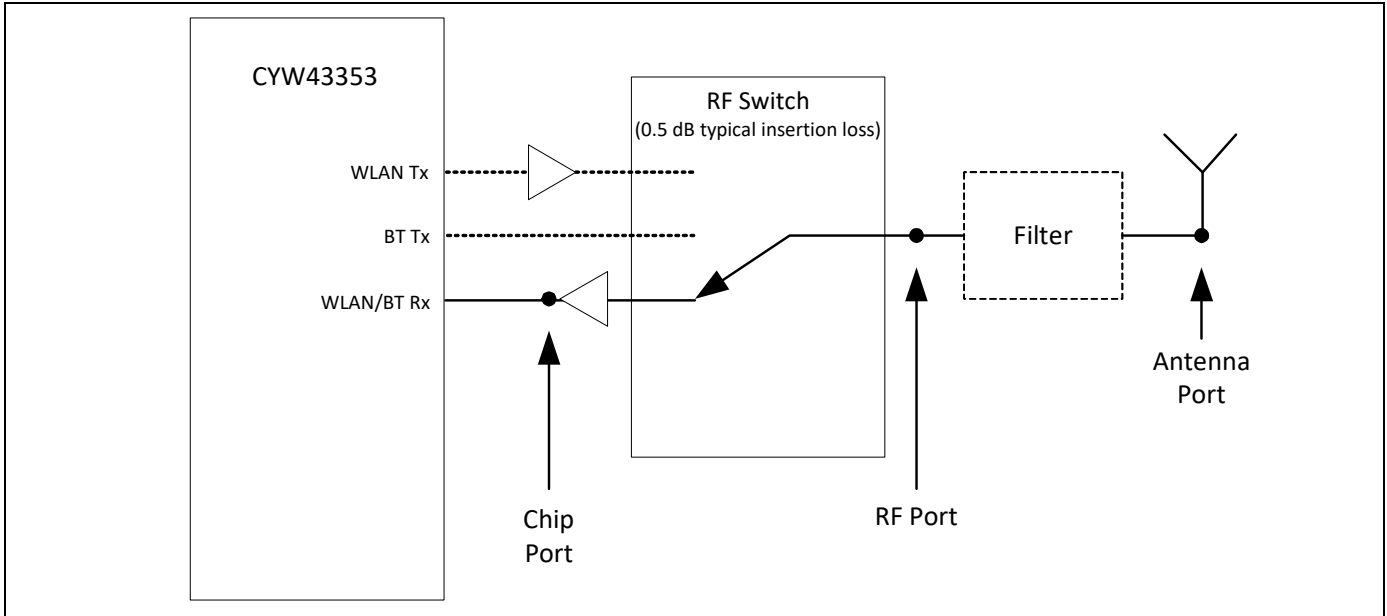

Note: All Bluetooth specifications are measured at the chip port unless otherwise specified.

Table 27. Bluetooth Receiver RF Specifications

Parameter	Conditions	Minimum	Typical	Maximum	Unit
Note: The specifications in this table are measured at the chip port output unless otherwise specified.					
General					
Frequency range	–	2402	–	2480	MHz
RX sensitivity	GFSK, 0.1% BER, 1 Mbps	–	–93.5	–	dBm
	$\pi/4$ -DQPSK, 0.01% BER, 2 Mbps	–	–95.5	–	dBm
	8-DPSK, 0.01% BER, 3 Mbps	–	–89.5	–	dBm
Input IP3	–	–16	–	–	dBm
Maximum input at antenna	–	–	–	–20	dBm
RX LO Leakage					
2.4 GHz band	–	–	–90.0	–80.0	dBm
Interference Performance¹					
C/I co-channel	GFSK, 0.1% BER	–	8	–	dB
C/I 1-MHz adjacent channel	GFSK, 0.1% BER	–	–7	–	dB
C/I 2-MHz adjacent channel	GFSK, 0.1% BER	–	–38	–	dB
C/I \geq 3-MHz adjacent channel	GFSK, 0.1% BER	–	–56	–	dB

Table 27. Bluetooth Receiver RF Specifications (Cont.)

Parameter	Conditions	Minimum	Typical	Maximum	Unit
C/I image channel	GFSK, 0.1% BER	–	–31	–	dB
C/I 1-MHz adjacent to image channel	GFSK, 0.1% BER	–	–46	–	dB
C/I co-channel	$\pi/4$ -DQPSK, 0.1% BER	–	9	–	dB
C/I 1-MHz adjacent channel	$\pi/4$ -DQPSK, 0.1% BER	–	–11	–	dB
C/I 2-MHz adjacent channel	$\pi/4$ -DQPSK, 0.1% BER	–	–39	–	dB
C/I \geq 3-MHz adjacent channel	$\pi/4$ -DQPSK, 0.1% BER	–	–55	–	dB
C/I image channel	$\pi/4$ -DQPSK, 0.1% BER	–	–23	–	dB
C/I 1-MHz adjacent to image channel	$\pi/4$ -DQPSK, 0.1% BER	–	–43	–	dB
C/I co-channel	8-DPSK, 0.1% BER	–	17	–	dB
C/I 1 MHz adjacent channel	8-DPSK, 0.1% BER	–	–4	–	dB
C/I 2 MHz adjacent channel	8-DPSK, 0.1% BER	–	–37	–	dB
C/I \geq 3-MHz adjacent channel	8-DPSK, 0.1% BER	–	–53	–	dB
C/I Image channel	8-DPSK, 0.1% BER	–	–16	–	dB
C/I 1-MHz adjacent to image channel	8-DPSK, 0.1% BER	–	–37	–	dB
Out-of-Band Blocking Performance (CW)					
30–2000 MHz	0.1% BER	–	–10.0	–	dBm
2000–2399 MHz	0.1% BER	–	–27	–	dBm
2498–3000 MHz	0.1% BER	–	–27	–	dBm
3000 MHz–12.75 GHz	0.1% BER	–	–10.0	–	dBm
Out-of-Band Blocking Performance, Modulated Interferer					
GFSK (1 Mbps)²					
698–716 MHz	WCDMA	–	–13.5	–	dBm
776–849 MHz	WCDMA	–	–13.8	–	dBm
824–849 MHz	GSM850	–	–13.5	–	dBm
824–849 MHz	WCDMA	–	–14.3	–	dBm
880–915 MHz	E-GSM	–	–13.1	–	dBm
880–915 MHz	WCDMA	–	–13.1	–	dBm
1710–1785 MHz	GSM1800	–	–18.1	–	dBm
1710–1785 MHz	WCDMA	–	–17.4	–	dBm
1850–1910 MHz	GSM1900	–	–19.4	–	dBm
1850–1910 MHz	WCDMA	–	–18.8	–	dBm
1880–1920 MHz	TD-SCDMA	–	–19.7	–	dBm
1920–1980 MHz	WCDMA	–	–19.6	–	dBm
2010–2025 MHz	TD-SCDMA	–	–20.4	–	dBm
2500–2570 MHz	WCDMA	–	–20.4	–	dBm
2500–2570 MHz ⁵	Band 7	–	–30.5	–	dBm
2300–2400 MHz ⁶	Band 40	–	–34.0	–	dBm
2570–2620 MHz ³	Band 38	–	–30.8	–	dBm
2545–2575 MHz ⁴	XGP Band	–	–29.5	–	dBm
$\pi/4$ DPSK (2 Mbps)²					
698–716 MHz	WCDMA	–	–9.8	–	dBm
776–794 MHz	WCDMA	–	–9.7	–	dBm
824–849 MHz	GSM850	–	–10.7	–	dBm

Table 27. Bluetooth Receiver RF Specifications (Cont.)

Parameter	Conditions	Minimum	Typical	Maximum	Unit
824–849 MHz	WCDMA	–	–11.4	–	dBm
880–915 MHz	E-GSM	–	–10.4	–	dBm
880–915 MHz	WCDMA	–	–10.2	–	dBm
1710–1785 MHz	GSM1800	–	–15.8	–	dBm
1710–1785 MHz	WCDMA	–	–15.4	–	dBm
1850–1910 MHz	GSM1900	–	–16.6	–	dBm
1850–1910 MHz	WCDMA	–	–16.4	–	dBm
1880–1920 MHz	TD-SCDMA	–	–17.9	–	dBm
1920–1980 MHz	WCDMA	–	–16.8	–	dBm
2010–2025 MHz	TD-SCDMA	–	–18.6	–	dBm
2500–2570 MHz	WCDMA	–	–20.4	–	dBm
2500–2570 MHz ⁵	Band 7	–	–31.9	–	dBm
2300–2400 MHz ⁶	Band 40	–	–35.3	–	dBm
2570–2620 MHz ³	Band 38	–	–31.8	–	dBm
2545–2575 MHz ⁴	XGP Band	–	–31.1	–	dBm
8DPSK (3 Mbps)²					
698–716 MHz	WCDMA	–	–12.6	–	dBm
776–794 MHz	WCDMA	–	–12.6	–	dBm
824–849 MHz	GSM850	–	–12.7	–	dBm
824–849 MHz	WCDMA	–	–13.7	–	dBm
880–915 MHz	E-GSM	–	–12.8	–	dBm
880–915 MHz	WCDMA	–	–12.6	–	dBm
1710–1785 MHz	GSM1800	–	–18.1	–	dBm
1710–1785 MHz	WCDMA	–	–17.4	–	dBm
1850–1910 MHz	GSM1900	–	–19.1	–	dBm
1850–1910 MHz	WCDMA	–	–18.6	–	dBm
1880–1920 MHz	TD-SCDMA	–	–19.3	–	dBm
1920–1980 MHz	WCDMA	–	–18.9	–	dBm
2010–2025 MHz	TD-SCDMA	–	–20.4	–	dBm
2500–2570 MHz	WCDMA	–	–21.4	–	dBm
2500–2570 MHz ⁵	Band 7	–	–31.0	–	dBm
2300–2400 MHz ⁶	Band 40	–	–34.5	–	dBm
2570–2620 MHz ³	Band 38	–	–31.2	–	dBm
2545–2575 MHz ⁴	XGP Band	–	–30.0	–	dBm

Table 27. Bluetooth Receiver RF Specifications (Cont.)

Parameter	Conditions	Minimum	Typical	Maximum	Unit
Spurious Emissions					
30 MHz–1 GHz		–	–95	–62	dBm
1–12.75 GHz		–	–70	–47	dBm
851–894 MHz		–	–147	–	dBm/Hz
925–960 MHz		–	–147	–	dBm/Hz
1805–1880 MHz		–	–147	–	dBm/Hz
1930–1990 MHz		–	–147	–	dBm/Hz
2110–2170 MHz		–	–147	–	dBm/Hz

1. The maximum value represents the actual Bluetooth specification required for Bluetooth qualification as defined in the version 4.1 specification.
2. Bluetooth reference level is taken at the 3 dB RX desense on each of the modulation schemes.
3. Interferer: 2380 MHz, BW=10 MHz; measured at 2480 MHz.
4. Interferer: 2355 MHz, BW=10 MHz; measured at 2480 MHz.
5. Interferer: 2560 MHz, BW=10 MHz; measured at 2480 MHz.
6. Interferer: 2360 MHz, BW=10 MHz; measured at 2402 MHz.

Table 28. Bluetooth Transmitter RF Specifications

Parameter	Conditions	Minimum	Typical	Maximum	Unit
Note: The specifications in this table are measured at the chip port output unless otherwise specified.					
General					
Frequency range		2402	–	2480	MHz
Basic rate (GFSK) TX power at Bluetooth ¹		11.0	13.0	–	dBm
QPSK TX Power at Bluetooth ¹		8.0	10.0	–	dBm
8PSK TX Power at Bluetooth ¹		8.0	10.0	–	dBm
Power control step		2	4	8	dB
Note: Output power is with TCA and TSSI enabled.					
GFSK In-Band Spurious Emissions					
–20 dBc BW		–	0.93	1	MHz
EDR In-Band Spurious Emissions					
1.0 MHz < M – N < 1.5 MHz	M – N = the frequency range for which the spurious emission is measured relative to the transmit center frequency.	–	–38	–26.0	dBc
1.5 MHz < M – N < 2.5 MHz		–	–31	–20.0	dBm
M – N ≥ 2.5 MHz ²		–	–43	–40.0	dBm
Out-of-Band Spurious Emissions					
30 MHz to 1 GHz		–	–	–36.0 ^{3, 4}	dBm
1 GHz to 12.75 GHz		–	–	–30.0 ^{b, 5, 6}	dBm
1.8 GHz to 1.9 GHz		–	–	–47.0	dBm
5.15 GHz to 5.3 GHz		–	–	–47.0	dBm
GPS Band Spurious Emissions					
Spurious emissions		–	–103	–	dBm

Table 28. Bluetooth Transmitter RF Specifications (Cont.)

Parameter	Conditions	Minimum	Typical	Maximum	Unit
Out-of-Band Noise Floor⁷					
65–108 MHz	FM RX	–	–147	–	dBm/Hz
776–794 MHz	CDMA2000	–	–147	–	dBm/Hz
869–960 MHz	cdmaOne, GSM850	–	–147	–	dBm/Hz
925–960 MHz	E-GSM	–	–147	–	dBm/Hz
1570–1580 MHz	GPS	–	–146	–	dBm/Hz
1805–1880 MHz	GSM1800	–	–145	–	dBm/Hz
1930–1990 MHz	GSM1900, cdmaOne, WCDMA	–	–144	–	dBm/Hz
2110–2170 MHz	WCDMA	–	–141	–	dBm/Hz
2500–2570 MHz	Band 7	–	–140	–	dBm/Hz
2300–2400 MHz	Band 40	–	–140	–	dBm/Hz
2570–2620 MHz	Band 38	–	–140	–	dBm/Hz
2545–2575 MHz	XGP Band	–	–140	–	dBm/Hz

1. Output power will be 1 dB lower at temperatures between –15°C and –40°C.
2. The typical number is measured at ±3 MHz offset.
3. The maximum value represents the value required for Bluetooth qualification as defined in the v4.1 specification.
4. The spurious emissions during Idle mode are the same as specified in [Table 28](#).
5. Specified at the Bluetooth Antenna port.
6. Meets this specification using a front-end band-pass filter.
7. Transmitted power in cellular at the Bluetooth Antenna port. See [Figure 30](#) for location of the port.

Table 29. Local Oscillator Performance

Parameter	Minimum	Typical	Maximum	Unit
LO Performance				
Lock time	–	72	–	μs
Initial carrier frequency tolerance	–	±25	±75	kHz
Frequency Drift				
DH1 packet	–	±8	±25	kHz
DH3 packet	–	±8	±40	kHz
DH5 packet	–	±8	±40	kHz
Drift rate	–	5	20	kHz/50 μs
Frequency Deviation				
00001111 sequence in payload ¹	140	155	175	kHz
10101010 sequence in payload ²	115	140	–	kHz
Channel spacing	–	1	–	MHz

1. This pattern represents an average deviation in payload.
2. Pattern represents the maximum deviation in payload for 99.9% of all frequency deviations.

Table 30. BLE RF Specifications

Parameter	Conditions	Minimum	Typical	Maximum	Unit
Frequency range	–	2402		2480	MHz
RX sense ¹	GFSK, 0.1% BER, 1 Mbps	–	–95.5	–	dBm
TX power ²	–	–	8.5	–	dBm
Mod Char: delta F1 average	–	225	255	275	kHz
Mod Char: delta F2 max ³	–	99.9	–	–	%
Mod Char: ratio	–	0.8	0.95	–	%

1. Dirty TX is On.
2. BLE TX power can be increased to compensate for front-end losses such as BPF, diplexer, switch, etc.). The output is capped at 12 dBm out. The BLE TX power at the antenna port cannot exceed the 10 dBm specification limit.
3. At least 99.9% of all delta F2 max frequency values recorded over 10 packets must be greater than 185 kHz

15. WLAN RF Specifications

15.1 Introduction

The CYW43353 includes an integrated dual-band direct conversion radio that supports the 2.4 GHz and the 5 GHz bands. This section describes the RF characteristics of the 2.4 GHz and 5 GHz radio.

Unless otherwise stated, limit values apply for the conditions specified in Table 24, “Environmental Ratings,” and Table 26, “Recommended Operating Conditions and DC Characteristics.”. Typical values apply for the following conditions:

- VBAT = 3.6V
- Ambient temperature +25°C

Figure 31. Port Locations Showing Optional ePA and eLNA (Applies to 2.4 GHz and 5 GHz)

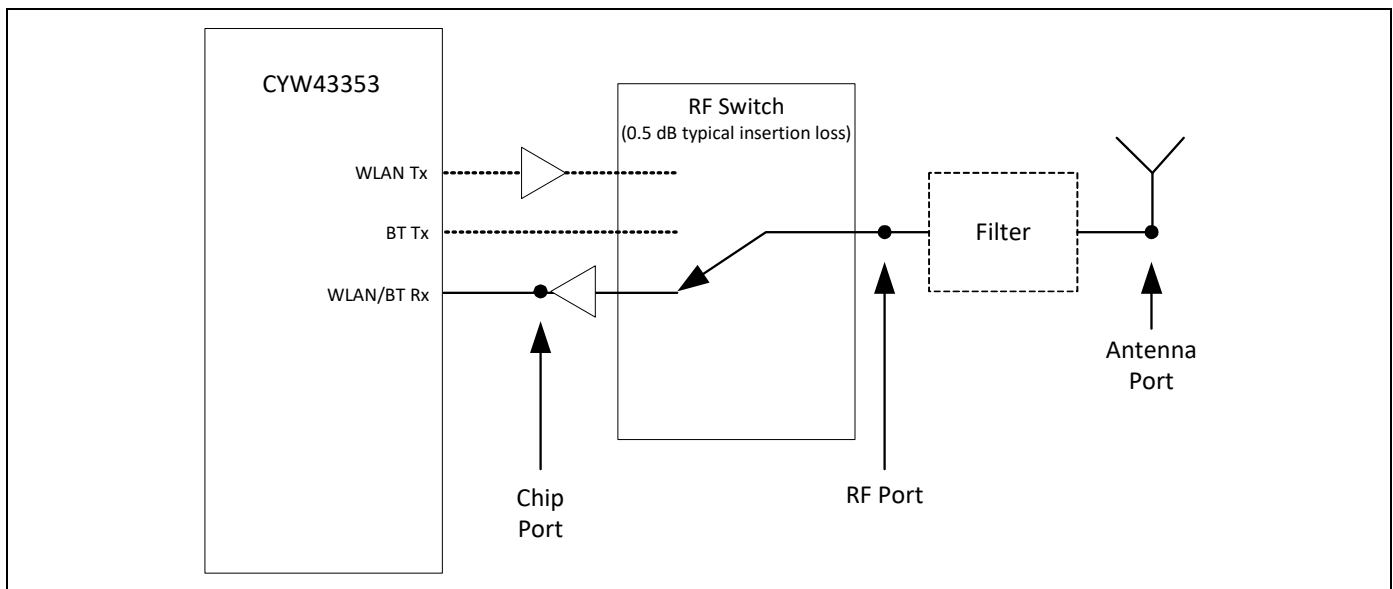

Note: All WLAN specifications are specified at the RF port, unless otherwise specified.

15.2 2.4 GHz Band General RF Specifications

Table 31. 2.4 GHz Band General RF Specifications

Item	Condition	Minimum	Typical	Maximum	Unit
TX/RX switch time	Including TX ramp down	–	–	5	μs
RX/TX switch time	Including TX ramp up	–	–	2	μs
Power-up and power-down ramp time	DSSS/CCK modulations	–	–	< 2	μs

15.3 WLAN 2.4 GHz Receiver Performance Specifications

Note: The specifications in Table 32 are specified at the RF port and include the use of an external FEM with LNA from Cypress's approved-vendor list (AVL), unless otherwise specified. Results with FEMs that are not on Cypress's AVL are not guaranteed.

Table 32. WLAN 2.4 GHz Receiver Performance Specifications

Parameter	Condition/Notes	Minimum	Typical	Maximum	Unit
Frequency range	–	2400	–	2500	MHz
RX sensitivity IEEE 802.11b (8% PER for 1024 octet PSDU) ¹	1 Mbps DSSS	–	–98.4	–	dBm
	2 Mbps DSSS	–	–96.5	–	dBm
	5.5 Mbps DSSS	–	–93.7	–	dBm
	11 Mbps DSSS	–	–91.4	–	dBm
RX sensitivity IEEE 802.11g (10% PER for 1024 octet PSDU) ^a	6 Mbps OFDM	–	–95.5	–	dBm
	9 Mbps OFDM	–	–94.1	–	dBm
	12 Mbps OFDM	–	–93.2	–	dBm
	18 Mbps OFDM	–	–90.6	–	dBm
	24 Mbps OFDM	–	–87.3	–	dBm
	36 Mbps OFDM	–	–84.0	–	dBm
	48 Mbps OFDM	–	–79.3	–	dBm
	54 Mbps OFDM	–	–77.8	–	dBm
RX sensitivity IEEE 802.11n (10% PER for 4096 octet PSDU) ^{a,2} . Defined for default parameters: 800 ns GI and non-STBC.	20 MHz channel spacing for all MCS rates				
	MCS0	–	–95.0	–	dBm
	MCS1	–	–92.7	–	dBm
	MCS2	–	–90.2	–	dBm
	MCS3	–	–87.1	–	dBm
	MCS4	–	–83.5	–	dBm
	MCS5	–	–78.9	–	dBm
	MCS6	–	–77.3	–	dBm
	MCS7	–	–75.7	–	dBm
RX sensitivity IEEE 802.11n (10% PER for 4096 octet PSDU) ^{a,3} . Defined for default parameters: 800 ns GI and non-STBC.	40 MHz channel spacing for all MCS rates				
	MCS0	–	–92.8	–	dBm
	MCS1	–	–89.9	–	dBm
	MCS2	–	–87.5	–	dBm
	MCS3	–	–84.0	–	dBm
	MCS4	–	–80.9	–	dBm
	MCS5	–	–76.2	–	dBm
	MCS6	–	–74.7	–	dBm
	MCS7	–	–73.3	–	dBm
RX sensitivity IEEE 802.11ac (10% PER for 4096 octet PSDU) ^{a,4} . Defined for default parameters: 800 ns GI and non-STBC	20 MHz channel spacing for all MCS rates				
	MCS0	–	–94.3	–	dBm
	MCS1	–	–91.9	–	dBm
	MCS2	–	–90.1	–	dBm
	MCS3	–	–86.9	–	dBm
	MCS4	–	–83.4	–	dBm
	MCS5	–	–78.9	–	dBm
	MCS6	–	–77.3	–	dBm
	MCS7	–	–75.6	–	dBm
MCS8	–	–71.2	–	dBm	

Table 32. WLAN 2.4 GHz Receiver Performance Specifications (Cont.)

Parameter	Condition/Notes		Minimum	Typical	Maximum	Unit
RX sensitivity IEEE 802.11ac (10% PER for 4096 octet PSDU) ^{a,5} . Defined for default parameters: 800 ns GI and non-STBC.	40 MHz channel spacing for all MCS rates					
		MCS0	–	–91.5	–	dBm
		MCS1	–	–89.0	–	dBm
		MCS2	–	–87.2	–	dBm
		MCS3	–	–84.0	–	dBm
		MCS4	–	–80.8	–	dBm
		MCS5	–	–76.3	–	dBm
		MCS6	–	–74.7	–	dBm
		MCS7	–	–73.3	–	dBm
		MCS8	–	–68.9	–	dBm
	MCS9	–	–67.6	–	dBm	
RX sensitivity IEEE 802.11ac 20/40/80 MHz channel spacing (10% PER for 4096 octet PSDU) at WLAN RF port. Defined for default parameters: 800 ns GI, and non-STBC.	MCS7	20 MHz	–	–77.4	–	dBm
	MCS8	20 MHz	–	–74.7	–	dBm
	MCS7	40 MHz	–	–74.6	–	dBm
	MCS8	40 MHz	–	–71.6	–	dBm
	MCS9	40 MHz	–	–70.1	–	dBm
	MCS7	80 MHz	–	–71.5	–	dBm
	MCS8	80 MHz	–	–68.1	–	dBm
	MCS9	80 MHz	–	–66.0	–	dBm
Blocking level for 3 dB RX sensitivity degradation (without external filtering) ⁶	776–794 MHz	CDMA2000	–	–24	–	dBm
	824–849 MHz ⁷	cdmaOne	–	–25	–	dBm
	824–849 MHz	GSM850	–	–15	–	dBm
	880–915 MHz	E-GSM	–	–16	–	dBm
	1710–1785 MHz	GSM1800	–	–18	–	dBm
	1850–1910 MHz	GSM1800	–	–19	–	dBm
	1850–1910 MHz	cdmaOne	–	–26	–	dBm
	1850–1910 MHz	WCDMA	–	–26	–	dBm
	1920–1980 MHz	WCDMA	–	–28.5	–	dBm
	2500–2570 MHz	Band 7	–	–45	–	dBm
	2300–2400 MHz	Band 40	–	–50	–	dBm
	2570–2620 MHz	Band 38	–	–45	–	dBm
2545–2575 MHz	XGP Band	–	–45	–	dBm	
In-band static CW jammer immunity ($f_c - 8 \text{ MHz} < f_{cw} < + 8 \text{ MHz}$)	RX PER < 1%, 54 Mbps OFDM, 1000 octet PSDU for: ($RxSens + 23 \text{ dB} < Rxlevel < \text{max input level}$)		–80	–	–	dBm
Input in-band IP3 ^a	Maximum LNA gain		–	–15.5	–	dBm
	Minimum LNA gain		–	–1.5	–	dBm
Maximum receive level @ 2.4 GHz	@ 1, 2 Mbps (8% PER, 1024 octets)		–3.5	–	–	dBm
	@ 5.5, 11 Mbps (8% PER, 1024 octets)		–9.5	–	–	dBm
	@ 6–54 Mbps (10% PER, 1024 octets)		–9.5	–	–	dBm
	@ MCS0–7 rates (10% PER, 4095 octets)		–9.5	–	–	dBm
	@ MCS8–9 rates (10% PER, 4095 octets)		–11.5	–	–	dBm
LPF 3 dB bandwidth	–		9	–	36	MHz

Table 32. WLAN 2.4 GHz Receiver Performance Specifications (Cont.)

Parameter	Condition/Notes	Minimum	Typical	Maximum	Unit	
Adjacent channel rejection—DSSS (Difference between interfering and desired signal at 8% PER for 1024 octet PSDU with desired signal level as specified in Condition/Notes)	Desired and interfering signal 30 MHz apart					
	1 Mbps DSSS	-74 dBm	35	-	-	dB
	2 Mbps DSSS	-74 dBm	35	-	-	dB
	Desired and interfering signal 25 MHz apart					
	5.5 Mbps DSSS	-70 dBm	35	-	-	dB
	11 Mbps DSSS	-70 dBm	35	-	-	dB
Adjacent channel rejection—OFDM (Difference between interfering and desired signal (25 MHz apart) at 10% PER for 1024 octet PSDU with desired signal level as specified in Condition/Notes)	6 Mbps OFDM	-79 dBm	16	-	-	dB
	9 Mbps OFDM	-78 dBm	15	-	-	dB
	12 Mbps OFDM	-76 dBm	13	-	-	dB
	18 Mbps OFDM	-74 dBm	11	-	-	dB
	24 Mbps OFDM	-71 dBm	8	-	-	dB
	36 Mbps OFDM	-67 dBm	4	-	-	dB
	48 Mbps OFDM	-63 dBm	0	-	-	dB
	54 Mbps OFDM	-62 dBm	-1	-	-	dB
Adjacent channel rejection MCS0–9 (Difference between interfering and desired signal (25 MHz apart) at 10% PER for 4096 octet PSDU with desired signal level as specified in Condition/Notes)	MCS0	-79 dBm	16	-	-	dB
	MCS1	-76 dBm	13	-	-	dB
	MCS2	-74 dBm	11	-	-	dB
	MCS3	-71 dBm	8	-	-	dB
	MCS4	-67 dBm	4	-	-	dB
	MCS5	-63 dBm	0	-	-	dB
	MCS6	-62 dBm	-1	-	-	dB
	MCS7	-61 dBm	-2	-	-	dB
	MCS8	-59 dBm	-4	-	-	dB
	MCS9	-57 dBm	-6	-	-	dB
Maximum receiver gain	-	-	95	-	dB	
Gain control step	-	-	3	-	dB	
RSSI accuracy ⁸	Range -95 dBm ⁹ to -30 dBm	-5	-	5	dB	
	Range above -30 dBm	-8	-	8	dB	
Return loss	Z _o = 50Ω, across the dynamic range	10	11.5	13	dB	
Receiver cascaded noise figure	At maximum gain	-	4	-	dB	

- Derate by 1.5 dB for -40°C to -10°C and 55°C to 85°C.
- Sensitivity degradations for alternate settings in MCS modes. MM: 0.5 dB drop, and SGI: 2 dB drop.
- Sensitivity degradations for alternate settings in MCS modes. MM: 0.5 dB drop, and SGI: 2 dB drop.
- Sensitivity degradations for alternate settings in MCS modes. MM: 0.5 dB drop, and SGI: 2 dB drop.
- Sensitivity degradations for alternate settings in MCS modes. MM: 0.5 dB drop, and SGI: 2 dB drop.
- The cellular standard listed for each band indicates the type of modulation used to generate the interfering signal in that band for the purpose of this test. It is not intended to indicate any specific usage of each band in any specific country.
- The blocking levels are valid for channels 1 to 11. (For higher channels, the performance may be lower due to third harmonic signals (3 × 824 MHz) falling within band.)
- The minimum and maximum values shown have a 95% confidence level.
- 95 dBm with calibration at the time of manufacture, -92 dBm without calibration.

15.4 WLAN 2.4 GHz Transmitter Performance Specifications

Note: The specifications in Table 33 include the use of the CYW43353's internal PAs and are specified at the chip port.

Table 33. WLAN 2.4 GHz Transmitter Performance Specifications

Parameter	Condition/Notes		Minimum	Typical	Maximum	Unit
Frequency range	–		2400	–	2500	MHz
Transmitted power in cellular and FM bands (at 18.5 dBm, 100% duty cycle, 1 Mbps CCK) ¹	76–108 MHz	FM RX	–	–148.5	–	dBm/Hz
	776–794 MHz	–	–	–126.5	–	dBm/Hz
	869–960 MHz	cdmaOne, GSM850	–	–162.5	–	dBm/Hz
	925–960 MHz	E-GSM	–	–162.5	–	dBm/Hz
	1570–1580 MHz	GPS	–	–149.5	–	dBm/Hz
	1805–1880 MHz	GSM1800	–	–140.5	–	dBm/Hz
	1930–1990 MHz	GSM1900, cdmaOne, WCDMA	–	–137.5	–	dBm/Hz
	2110–2170 MHz	WCDMA	–	–128.5	–	dBm/Hz
	2500–2570 MHz	Band 7	–	–104.5	–	dBm/Hz
	2300–2400 MHz	Band 40	–	–94.5	–	dBm/Hz
	2570–2620 MHz	Band 38	–	–119.5	–	dBm/Hz
Harmonic level (at 18 dBm with 100% duty cycle)	4.8–5.0 GHz	2nd harmonic	–	–7.5	–	dBm/1 MHz
	7.2–7.5 GHz	3rd harmonic	–	–17.5	–	dBm/1 MHz
EVM Does Not Exceed						
TX power at the chip port for highest power level setting at 25°C and VBAT = 3.6V with spectral mask and EVM compliance ^{2, 3}	802.11b (DSSS/CCK)	–9 dB	–	21.5	–	dBm
	OFDM, BPSK	–8 dB	–	20	–	dBm
	OFDM, QPSK	–13 dB	–	20	–	dBm
	OFDM, 16-QAM	–19 dB	–	19	–	dBm
	OFDM, 64-QAM (R = 3/4)	–25 dB	–	19	–	dBm
	OFDM, 64-QAM (MCS7, HT20)	–27 dB	–	19	–	dBm
	OFDM, 256-QAM (MCS8, VHT20)	–30 dB	–	17	–	dBm
	OFDM, 256-QAM (MCS8, VHT40)	–32 dB	–	17	–	dBm
Phase noise	37.4 MHz Crystal, Integrated from 10 kHz to 10 MHz		–	0.45	–	Degrees RMS
TX power control dynamic range	–		10	–	–	dB
Closed-loop TX power variation at highest power level setting	Across full temperature and voltage range. Applies across 10 dBm to 20 dBm output power range.		–	–	±1.5	dB
Carrier suppression	–		15	–	–	dBc
Gain control step	–		–	0.25	–	dB
Return loss at Chip port TX	Z _o = 50Ω		–	6	–	dB

1. The cellular standards listed indicate only typical usages of that band in some countries. Other standards may also be used within those bands.
2. Derate by 1.5 dB for temperatures less than –10°C or more than 55°C, or voltages less than 3.0V. Derate by 3.0 dB for voltages of less than 2.7V, or voltages of less than 3.0V at temperatures less than –10°C or greater than 55°C. Derate by 4.5 dB for –40°C to –30°C.
3. TX power for Channel 1 and Channel 11 is specified by nonvolatile memory parameters.

15.5 WLAN 5 GHz Receiver Performance Specifications

Note: The specifications in Table 34 are specified at the RF port and include the use of an external FEM with LNA from Cypress's approved-vendor list (AVL), unless otherwise specified. Results with FEMs that are not on Cypress's AVL are not guaranteed.

Table 34. WLAN 5 GHz Receiver Performance Specifications

Parameter	Condition/Notes	Minimum	Typical	Maximum	Unit
Frequency range	–	4900	–	5845	MHz
RX sensitivity IEEE 802.11a (10% PER for 1000 octet PSDU) ¹	6 Mbps OFDM	–	–94.5	–	dBm
	9 Mbps OFDM	–	–93.1	–	dBm
	12 Mbps OFDM	–	–92.2	–	dBm
	18 Mbps OFDM	–	–89.6	–	dBm
	24 Mbps OFDM	–	–86.3	–	dBm
	36 Mbps OFDM	–	–83	–	dBm
	48 Mbps OFDM	–	–78.3	–	dBm
	54 Mbps OFDM	–	–76.8	–	dBm
RX sensitivity IEEE 802.11n (10% PER for 4096 octet PSDU) ^a Defined for default parameters: 800 ns GI and non-STBC.	20 MHz channel spacing for all MCS rates				
	MCS0	–	–94	–	dBm
	MCS1	–	–91.7	–	dBm
	MCS2	–	–89.2	–	dBm
	MCS3	–	–86.1	–	dBm
	MCS4	–	–82.5	–	dBm
	MCS5	–	–77.9	–	dBm
	MCS6	–	–76.3	–	dBm
RX sensitivity IEEE 802.11n (10% PER for 4096 octet PSDU) ^a Defined for default parameters: 800 ns GI and non-STBC.	40 MHz channel spacing for all MCS rates				
	MCS0	–	–91.8	–	dBm
	MCS1	–	–88.9	–	dBm
	MCS2	–	–86.5	–	dBm
	MCS3	–	–83.0	–	dBm
	MCS4	–	–79.9	–	dBm
	MCS5	–	–75.2	–	dBm
	MCS6	–	–73.7	–	dBm
RX sensitivity IEEE 802.11ac (10% PER for 4096 octet PSDU) ^a Defined for default parameters: 800 ns GI and non-STBC.	20 MHz channel spacing for all MCS rates				
	MCS0	–	–93.3	–	dBm
	MCS1	–	–90.3	–	dBm
	MCS2	–	–87.9	–	dBm
	MCS3	–	–84.9	–	dBm
	MCS4	–	–81.4	–	dBm
	MCS5	–	–76.7	–	dBm
	MCS6	–	–75.1	–	dBm
	MCS7	–	–74.6	–	dBm
MCS8	–	–70.2	–	dBm	

Table 34. WLAN 5 GHz Receiver Performance Specifications (Cont.)

Parameter	Condition/Notes		Minimum	Typical	Maximum	Unit
RX sensitivity IEEE 802.11ac (10% PER for 4096 octet PSDU) ^a Defined for default parameters: 800 ns GI and non-STBC.	40 MHz channel spacing for all MCS rates					
	MCS0		–	–90.5	–	dBm
	MCS1		–	–87.4	–	dBm
	MCS2		–	–85.3	–	dBm
	MCS3		–	–82.1	–	dBm
	MCS4		–	–79	–	dBm
	MCS5		–	–73.9	–	dBm
	MCS6		–	–72.4	–	dBm
	MCS7		–	–72.3	–	dBm
	MCS8		–	–67.9	–	dBm
MCS9		–	–66.6	–	dBm	
RX sensitivity IEEE 802.11ac (10% PER for 4096 octet PSDU) ^a Defined for default parameters: 800 ns GI and non-STBC.	80 MHz channel spacing for all MCS rates					
	MCS0		–	–87	–	dBm
	MCS1		–	–83.9	–	dBm
	MCS2		–	–81.9	–	dBm
	MCS3		–	–78.1	–	dBm
	MCS4		–	–75	–	dBm
	MCS5		–	–73	–	dBm
	MCS6		–	–68.5	–	dBm
	MCS7		–	–68.5	–	dBm
	MCS8		–	–64.3	–	dBm
MCS9		–	–62.7	–	dBm	
RX sensitivity IEEE 802.11ac 20/40/80 MHz channel spacing (10% PER for 4096 octet PSDU) at WLAN RF port. Defined for default parameters: 800 ns GI, and non-STBC.	MCS7	20 MHz	–	–76.4	–	dBm
	MCS8	20 MHz	–	–73.7	–	dBm
	MCS7	40 MHz	–	–73.6	–	dBm
	MCS8	40 MHz	–	–70.6	–	dBm
	MCS9	40 MHz	–	–69.1	–	dBm
	MCS7	80 MHz	–	–70.5	–	dBm
	MCS8	80 MHz	–	–67.1	–	dBm
	MCS9	80 MHz	–	–65.0	–	dBm
Blocking level for 1 dB RX sensitivity degradation (without external filtering) ²	776–794 MHz	CDMA2000	–21	–	–	dBm
	824–849 MHz	cdmaOne	–20	–	–	dBm
	824–849 MHz	GSM850	–12	–	–	dBm
	880–915 MHz	E-GSM	–12	–	–	dBm
	1710–1785 MHz	GSM1800	–15	–	–	dBm
	1850–1910 MHz	GSM1800	–15	–	–	dBm
	1850–1910 MHz	cdmaOne	–20	–	–	dBm
	1850–1910 MHz	WCDMA	–21	–	–	dBm
	1920–1980 MHz	WCDMA	–21	–	–	dBm
	2500–2570 MHz	Band 7	–21	–	–	dBm
	2300–2400 MHz	Band 40	–21	–	–	dBm
	2570–2620 MHz	Band 38	–21	–	–	dBm
2545–2575 MHz	XGP Band	–21	–	–	dBm	
Input in-band IP3 ^a	Maximum LNA gain		–	–15.5	–	dBm
	Minimum LNA gain		–	–1.5	–	dBm

Table 34. WLAN 5 GHz Receiver Performance Specifications (Cont.)

Parameter	Condition/Notes	Minimum	Typical	Maximum	Unit
Maximum receive level @ 5.24 GHz	@ 6, 9, 12 Mbps	-9.5	-	-	dBm
	@ 18, 24, 36, 48, 54 Mbps	-14.5	-	-	dBm
LPF 3 dB bandwidth	-	9	-	36	MHz
Adjacent channel rejection (Difference between interfering and desired signal (20 MHz apart) at 10% PER for 1000 octet PSDU with desired signal level as specified in Condition/Notes)	6 Mbps OFDM	-79 dBm	16	-	dB
	9 Mbps OFDM	-78 dBm	15	-	dB
	12 Mbps OFDM	-76 dBm	13	-	dB
	18 Mbps OFDM	-74 dBm	11	-	dB
	24 Mbps OFDM	-71 dBm	8	-	dB
	36 Mbps OFDM	-67 dBm	4	-	dB
	48 Mbps OFDM	-63 dBm	0	-	dB
	54 Mbps OFDM	-62 dBm	-1	-	dB
	65 Mbps OFDM	-61 dBm	-2	-	dB
Alternate adjacent channel rejection (Difference between interfering and desired signal (40 MHz apart) at 10% PER for 1000 ³ octet PSDU with desired signal level as specified in Condition/Notes)	6 Mbps OFDM	-78.5 dBm	32	-	dB
	9 Mbps OFDM	-77.5 dBm	31	-	dB
	12 Mbps OFDM	-75.5 dBm	29	-	dB
	18 Mbps OFDM	-73.5 dBm	27	-	dB
	24 Mbps OFDM	-70.5 dBm	24	-	dB
	36 Mbps OFDM	-66.5 dBm	20	-	dB
	48 Mbps OFDM	-62.5 dBm	16	-	dB
	54 Mbps OFDM	-61.5 dBm	15	-	dB
65 Mbps OFDM	-60.5 dBm	14	-	dB	
Maximum receiver gain	-	-	95	-	dB
Gain control step	-	-	3	-	dB
RSSI accuracy ⁴	Range -95 dBm ⁵ to -30 dBm	-5	-	5	dB
	Range above -30 dBm	-8	-	8	dB
Return loss	Z _o = 50Ω, across the dynamic range	10	-	13	dB
Receiver cascaded noise figure	At maximum gain	-	4	6	dB

1. Derate by 1.5 dB for -40°C to -10°C and 55°C to 85°C.
2. The cellular standard listed for each band indicates the type of modulation used to generate the interfering signal in that band for the purpose of this test. It is not intended to indicate any specific usage of each band in any specific country.
3. For 65 Mbps, the size is 4096.
4. The minimum and maximum values shown have a 95% confidence level.
5. -95 dBm with calibration at the time of manufacture, -92 dBm without calibration.

15.6 WLAN 5 GHz Transmitter Performance Specifications

Note: The specifications in Table 34 include the use of the CYW43353's internal PAs and are specified at the chip port.

Table 35. WLAN 5 GHz Transmitter Performance Specifications

Parameter	Condition/Notes		Minimum	Typical	Maximum	Unit
Frequency range	–		4900	–	5845	MHz
Transmitted power in cellular and FM bands (at 18.5 dBm) ¹	76–108 MHz	FM RX	–	–161.5	–	dBm/Hz
	776–794 MHz	–	–	–161.5	–	dBm/Hz
	869–960 MHz	cdmaOne, GSM850	–	–161.5	–	dBm/Hz
	925–960 MHz	E-GSM	–	–161.5	–	dBm/Hz
	1570–1580 MHz	GPS	–	–161.5	–	dBm/Hz
	1805–1880 MHz	GSM1800	–	–159.5	–	dBm/Hz
	1930–1990 MHz	GSM1900, cdmaOne, WCDMA	–	–161.5	–	dBm/Hz
	2110–2170 MHz	WCDMA	–	–158.5	–	dBm/Hz
	2400–2483 MHz	BT/WLAN	–	–156.5	–	dBm/Hz
	2500–2570 MHz	Band 7	–	–156.5	–	dBm/Hz
	2300–2400 MHz	Band 40	–	–156.5	–	dBm/Hz
	2570–2620 MHz	Band 38	–	–156.5	–	dBm/Hz
2545–2575 MHz	XGP band	–	–156.5	–	dBm/Hz	
Harmonic level (at 17 dBm)	9.8–11.570 GHz	2nd harmonic	–	–30.5	–	dBm/MHz
TX power at the chip port for highest power level setting at 25°C and VBAT = 3.6V with spectral mask and EVM compliance ^{2, 3}	OFDM, QPSK	–13 dB	–	21.5	–	dBm
	OFDM, 16-QAM	–19 dB	–	19	–	dBm
	OFDM, 64-QAM (R = 3/4)	–25 dB	–	19	–	dBm
	OFDM, 64-QAM (MCS7, HT20)	–27 dB	–	19	–	dBm
	OFDM, 256-QAM (MCS8, VHT80)	–30 dB	–	17	–	dBm
	OFDM, 256-QAM (MCS9, VHT40 and VHT80)	–32 dB	–	17	–	dBm
Phase noise	37.4 MHz crystal, integrated from 10 kHz to 10 MHz		–	0.45	–	Degrees RMS
TX power control dynamic range	–		10	–	–	dB
Closed loop TX power variation at highest power level setting	Across full-temperature and voltage range. Applies across 10 to 20 dBm output power range.		–	–	±2.0	dB
Carrier suppression	–		15	–	–	dBc
Gain control step	–		–	0.25	–	dB
Return loss	Z _o = 50Ω		–	6	–	dB

- The cellular standards listed indicate only typical usages of that band in some countries. Other standards may also be used within those bands.
- Derate by 1.5 dB for temperatures less than –10°C or more than 55°C, or voltages less than 3.0V. Derate by 3.0 dB for voltages of less than 2.7V, or voltages of less than 3.0V at temperatures less than –10°C or greater than 55°C. Derate by 4.5 dB for –40°C to –30°C.
- TX power for Channel 1 and Channel 11 is specified by non-volatile memory parameters.

15.7 General Spurious Emissions Specifications

Table 36. General Spurious Emissions Specifications

Parameter	Condition/Notes		Min.	Typ.	Max.	Unit
Frequency range	–		2400	–	2500	MHz
General Spurious Emissions						
TX emissions	30 MHz < f < 1 GHz	RBW = 100 kHz	–	–93	–	dBm
	1 GHz < f < 12.75 GHz	RBW = 1 MHz	–	–45.5	–	dBm
	1.8 GHz < f < 1.9 GHz	RBW = 1 MHz	–	–72	–	dBm
	5.15 GHz < f < 5.3 GHz	RBW = 1 MHz	–	–87	–	dBm
RX/standby emissions	30 MHz < f < 1 GHz	RBW = 100 kHz	–	–107	–	dBm
	1 GHz < f < 12.75 GHz	RBW = 1 MHz	–	–65 ¹	–	dBm
	1.8 GHz < f < 1.9 GHz	RBW = 1 MHz	–	–87	–	dBm
	5.15 GHz < f < 5.3 GHz	RBW = 1 MHz	–	–100	–	dBm

1. The value presented in this table is the result of LO leakage at $3/2 * f_c$ for 2.4 GHz or $2/3 * f_c$ for 5 GHz (where f_c is the carrier frequency). For all other emissions in this range, the value is –96 dBm.

16. Internal Regulator Electrical Specifications

Functional operation is not guaranteed outside of the specification limits provided in this section.

16.1 Core Buck Switching Regulator

Table 37. Core Buck Switching Regulator (CLOCK) Specifications

Specification	Notes	Min.	Typ.	Max.	Units
Input supply voltage (DC)	DC voltage range inclusive of disturbances.	3.0	3.6	4.8 ¹	V
PWM mode switching frequency	CCM, Load > 100 mA VBAT = 3.6V	2.8	4	5.2	MHz
PWM output current	–	–	–	600	mA
Output current limit	–	–	1400	–	mA
Output voltage range	Programmable, 30 mV steps Default = 1.35V	1.2	1.35	1.5	V
PWM output voltage DC accuracy	Includes load and line regulation. Forced PWM mode	–4	–	4	%
PWM ripple voltage, static	Measure with 20 MHz bandwidth limit. Static Load. Max. Ripple based on VBAT = 3.6V, Vout = 1.35V, Fsw = 4 MHz, 2.2 μH inductor L > 1.05 μH, Cap + Board total-ESR < 20 mΩ, Cout > 1.9 μF, ESL < 200pH	–	7	20	mVpp
PWM mode peak efficiency	Peak Efficiency at 200 mA load	78	86	–	%
PFM mode efficiency	10 mA load current	70	81	–	%
Start-up time from power down	VIO already ON and steady. Time from REG_ON rising edge to CLDO reaching 1.2V	–	–	850	μs
External inductor	0806 size, ± 30%, 0.11 ± 25% Ohms	–	2.2	–	μH
External output capacitor	Ceramic, X5R, 0402, ESR < 30 mΩ at 4 MHz, ± 20%, 6.3V	2.0 ²	4.7	10 ³	μF
External input capacitor	For SR_VDDBATP5V pin, ceramic, X5R, 0603, ESR < 30 mΩ at 4 MHz, ± 20%, 6.3V, 4.7 μF	0.67 ²	4.7	–	μF

Table 37. Core Buck Switching Regulator (CBUCK) Specifications (Cont.)

Specification	Notes	Min.	Typ.	Max.	Units
Input supply voltage ramp-up time	0 to 4.3V	40	–	–	μs

1. The maximum continuous voltage is 4.8V. Voltage transients up to 6.0V (for up to 10 seconds), cumulative duration over the lifetime of the device, are allowed. Voltage transients as high as 5.0V (for up to 250 seconds), cumulative duration over the lifetime of the device, are allowed.
2. Minimum capacitor value refers to the residual capacitor value after taking into account the part-to-part tolerance, DC-bias, temperature, and aging.
3. Total capacitance includes those connected at the far end of the active load.

16.2 3.3V LDO (LDO3P3)

Table 38. LDO3P3 Specifications

Specification	Notes	Min.	Typ.	Max.	Units
Input supply voltage, V_{in}	Min. = $V_o + 0.2V = 3.5V$ dropout voltage requirement must be met under maximum load for performance specifications.	3.0	3.6	4.8 ¹	V
Output current	–	0.001	–	450	mA
Nominal output voltage, V_o	Default = 3.3V	–	3.3	–	V
Dropout voltage	At max load.	–	–	200	mV
Output voltage DC accuracy	Includes line/load regulation.	–5	–	+5	%
Quiescent current	No load	–	–	100	μA
Line regulation	V_{in} from ($V_o + 0.2V$) to 4.8V, max load	–	–	3.5	mV/V
Load regulation	load from 1 mA to 450 mA	–	–	0.3	mV/mA
PSRR	$V_{in} \geq V_o + 0.2V$, $V_o = 3.3V$, $C_o = 4.7 \mu F$, Max. load, 100 Hz to 100 kHz	20	–	–	dB
LDO turn-on time	Chip already powered up.	–	160	250	μs
External output capacitor, C_o	Ceramic, X5R, 0402, (ESR: 5 mΩ–240 mΩ), ± 10%, 10V	1.0 ²	4.7	10	μF
External input capacitor	For SR_VDDBATA5V pin (shared with Bandgap) Ceramic, X5R, 0402, (ESR: 30m–200 mΩ), ± 10%, 10V. Not needed if sharing VBAT capacitor 4.7 μF with SR_VDDBATP5V.	–	4.7	–	μF

1. The maximum continuous voltage is 4.8V. Voltage transients up to 6.0V (for up to 10 seconds), cumulative duration over the lifetime of the device, are allowed. Voltage transients as high as 5.0V (for up to 250 seconds), cumulative duration over the lifetime of the device, are allowed.
2. Minimum capacitor value refers to the residual capacitor value after taking into account the part-to-part tolerance, DC-bias, temperature, and aging.

16.3 2.5V LDO (BTLDO2P5)

Table 39. BTLDO2P5 Specifications

Specification	Notes	Min.	Typ.	Max.	Units
Input supply voltage	Min. = 2.5V + 0.2V = 2.7V. Dropout voltage requirement must be met under maximum load for performance specifications.	3.0	3.6	4.8 ¹	V
Nominal output voltage	Default = 2.5V.	–	2.5	–	V
Output voltage programmability	Range	2.2	2.5	2.8	V
	Accuracy at any step (including line/load regulation), load > 0.1 mA.	–5	–	5	%
Dropout voltage	At maximum load.	–	–	200	mV
Output current	–	0.1	–	70	mA
Quiescent current	No load.	–	8	16	μA
	Maximum load at 70 mA.	–	660	700	μA
Leakage current	Power-down mode.	–	1.5	5	μA
Line regulation	V _{in} from (V _o + 0.2V) to 4.8V, maximum load.	–	–	3.5	mV/V
Load regulation	Load from 1 mA to 70 mA, V _{in} = 3.6V.	–	–	0.3	mV/mA
PSRR	V _{in} ≥ V _o + 0.2V, V _o = 2.5V, C _o = 2.2 μF, maximum load, 100 Hz to 100 kHz.	20	–	–	dB
LDO turn-on time	Chip already powered up.	–	–	150	μs
In-rush current	V _{in} = V _o + 0.15V to 4.8V, C _o = 2.2 μF, No load.	–	–	250	mA
External output capacitor, C _o	Ceramic, X5R, 0402, (ESR: 5–240 mΩ), ±10%, 10V	0.7 ²	2.2	2.64	μF
External input capacitor	For SR_VDDBATA5V pin (shared with Bandgap) ceramic, X5R, 0402, (ESR: 30–200 mΩ), ±10%, 10V. Not needed if sharing VBAT 4.7 μF capacitor with SR_VDDBATP5V.	–	4.7	–	μF

1. The maximum continuous voltage is 4.8V. Voltage transients up to 6.0V (for up to 10 seconds), cumulative duration over the lifetime of the device, are allowed. Voltage transients as high as 5.0V (for up to 250 seconds), cumulative duration over the lifetime of the device, are allowed.

2. The minimum value refers to the residual capacitor value after taking into account part-to-part tolerance, DC-bias, temperature, and aging.

16.4 CLDO

Table 40. CLDO Specifications

Specification	Notes	Min.	Typ.	Max.	Units
Input supply voltage, V_{in}	Min. = $1.2 + 0.15V = 1.35V$ dropout voltage requirement must be met under maximum load.	1.3	1.35	1.5	V
Output current	–	0.2	–	300	mA
Output voltage, V_o	Programmable in 25 mV steps. Default = 1.2V	1.1	1.2	1.275	V
Dropout voltage	At max. load	–	–	150	mV
Output voltage DC accuracy	Includes line/load regulation	–4	–	+4	%
Quiescent current	No load	–	24	–	μA
	300 mA load	–	2.1	–	mA
Line regulation	V_{in} from $(V_o + 0.15V)$ to 1.5V, maximum load	–	–	5	mV/V
Load regulation	Load from 1 mA to 300 mA	–	0.02	0.05	mV/mA
Leakage current	Power down	–	–	20	μA
	Bypass mode	–	1	3	μA
PSRR	@1 kHz, $V_{in} \geq 1.35V$, $C_o = 4.7 \mu F$	20	–	–	dB
Start-up time of PMU	VIO up and steady. Time from the REG_ON rising edge to the CLDO reaching 1.2V.	–	–	700	μs
LDO turn-on time	LDO turn-on time when rest of the chip is up	–	140	180	μs
External output capacitor, C_o	Total ESR: 5 m Ω –240 m Ω	1.32 ¹	4.7	–	μF
External input capacitor	Only use an external input capacitor at the VDD_LDO pin if it is not supplied from CBUCK output.	–	1	2.2	μF

1. Minimum capacitor value refers to the residual capacitor value after taking into account the part-to-part tolerance, DC-bias, temperature, and aging.

16.5 LNLDO

Table 41. LNLDO Specifications

Specification	Notes	Min.	Typ.	Max.	Units
Input supply voltage, V_{in}	Min. = $1.2V_o + 0.15V = 1.35V$ dropout voltage requirement must be met under maximum load.	1.3	1.35	1.5	V
Output current	–	0.1	–	150	mA
Output voltage, V_o	Programmable in 25 mV steps. Default = 1.2V	1.1	1.2	1.275	V
Dropout voltage	At maximum load	–	–	150	mV
Output voltage DC accuracy	Includes line/load regulation	–4	–	+4	%
Quiescent current	No load	–	44	–	μA
	Max. load	–	970	990	μA
Line regulation	V_{in} from ($V_o + 0.1V$) to 1.5V, max load	–	–	5	mV/V
Load regulation	Load from 1 mA to 150 mA	–	0.02	0.05	mV/mA
Leakage current	Power-down	–	–	10	μA
Output noise	@30 kHz, 60–150 mA load $C_o = 2.2 \mu F$	–	–	60	nV/rt Hz
	@100 kHz, 60–150 mA load $C_o = 2.2 \mu F$	–	–	35	nV/rt Hz
PSRR	@ 1kHz, Input > 1.35V, $C_o = 2.2 \mu F$, $V_o = 1.2V$	20	–	–	dB
LDO turn-on time	LDO turn-on time when rest of chip is up	–	140	180	μs
External output capacitor, C_o	Total ESR (trace/capacitor): 5 m Ω –240 m Ω	0.5 ¹	2.2	4.7	μF
External input capacitor	Only use an external input capacitor at the VDD_LDO pin if it is not supplied from CBUCK output. Total ESR (trace/capacitor): 30 m Ω –200 m Ω	–	1	2.2	μF

1. Minimum capacitor value refers to the residual capacitor value after taking into account the part-to-part tolerance, DC-bias, temperature, and aging.

17. System Power Consumption

Note: Unless otherwise stated, these values apply for the conditions specified in Table 26, “Recommended Operating Conditions and DC Characteristics,”.

17.1 WLAN Current Consumption

Table 42 shows the typical, total current consumed by the CYW43353. To calculate total-solution current consumption for designs using external PAs, LNAs, and/or FEMs, add the current consumption of the external devices to the numbers in Table 42.

All values in Table 42 are with the Bluetooth core in reset (that is, with Bluetooth off).

Table 42. Typical WLAN Current Consumption (CYW43353 Current Only)

Mode	Bandwidth (MHz)	Band (GHz)	VBAT = 3.6V, VDDIO = 1.8V, T _A 25°C	
			Vbat, mA	Vio ¹ , μA
Sleep Modes				
OFF ²	–	–	0.005	5
SLEEP ³	–	–	0.005	150
IEEE Power Save, DTIM 1 ⁴	–	2.4	0.850	150
IEEE Power Save, DTIM 3 ⁴	–	2.4	0.350	150
IEEE Power Save, DTIM 1 ⁴	–	5	0.550	150
IEEE Power Save, DTIM 3 ⁴	–	5	0.300	150
Active Modes				
Receive ^{5,6} MCS8 (SGI)	20	2.4	50	5
CRS ⁷	20	2.4	46	5
Receive ^{5,6} MCS7 (SGI)	20	5	66	5
CRS ⁷	20	5	56	5
Receive ^{5,6} MCS7 (SGI)	40	5	79.5	5
CRS ⁷	40	5	67	5
Receive ^{5,6} MCS9 (SGI)	80	5	110	5
CRS ⁷	80	5	103	5

Table 42. Typical WLAN Current Consumption (CYW43353 Current Only) (Cont.)

Mode	Bandwidth (MHz)	Band (GHz)	VBAT = 3.6V, VDDIO = 1.8V, T _A 25°C	
			Vbat, mA	Vio ¹ , μA
Active Modes with External PAs (TX Output Power is –5 dBm at the Chip Port)				
Transmit, CCK	20	2.4	88	5
Transmit, MCS8, HT20, SGI ^{5, 8}	20	2.4	76	5
Transmit, MCS7, SGI ^{5, 8}	20	5	111	5
Transmit, MCS7 ^{5, 8}	40	5	125	5
Transmit, MCS9, SGI ^{5, 8}	40	5	125	5
Transmit, MCS9, SGI ^{5, 8}	80	5	147	5
Active Modes with Internal PAs (TX Output Power Measured at the Chip Port)				
TX CCK 11 Mbps at 21.7 dBm	20	2.4	325	5
TX OFDM MCS8 (SGI) at 17.2 dBm	20	2.4	240	5
TX OFDM MCS7 (SGI) at 18.5 dBm	20	5	280	5
TX OFDM MCS7 at 18.7 dBm	40	5	340	5
TX OFDM MCS9 (SGI) at 16.2 dBm	40	5	270	5
TX OFDM MCS9 (SGI) at 15.7 dBm	80	5	270	5

1. VIO is specified with all pins idle (not switching) and not driving any loads.
2. WL_REG_ON, BT_REG_ON low.
3. Idle, not associated, or inter-beacon.
4. Beacon Interval = 102.4 ms. Beacon duration = 1 ms @1 Mbps. Average current over the specified DTIM intervals.
5. Measured using packet engine test mode.
6. Duty cycle is 100%. Carrier sense (CS) detect/packet receive.
7. Carrier sense (CCA) when no carrier present.
8. Duty cycle is 100%. Excludes external PA contribution.

17.2 Bluetooth Current Consumption

The Bluetooth BLE current consumption measurements are shown in [Table 43](#).

Note:

- The WLAN core is in reset (WLAN_REG_ON = low) for all measurements provided in [Table 43](#).
- The BT current consumption numbers are measured based on GFSK TX output power = 10 dBm.

Table 43. Bluetooth BLE Current Consumption

Operating Mode	VBAT (VBAT = 3.6V) Typical	VDDIO (VDDIO = 1.8V) Typical	Units
Sleep	10	225	μA
Standard 1.28s Inquiry Scan	180	235	μA
P and I Scan ²	320	235	μA
500 ms Sniff Master	170	250	μA
500 ms Sniff Slave	120	250	μA
DM1/DH1 Master	22.81	0.034	mA
DM3/DH3 Master	28.06	0.044	mA
DM5/DH5 Master	29.01	0.047	mA
3DH5 Master	27.09	0.100	mA
SCO HV3 Master	7.9	0.123	mA
HV3 + Sniff + Scan ¹	11.38	0.180	mA
BLE Scan ²	175	235	μA
BLE Scan 10 ms	14.09	0.022	mA
BLE Adv – Unconnectable 1.00 sec	69	245	μA
BLE Adv – Unconnectable 1.28 sec	67	235	μA
BLE Adv – Unconnectable 2.00 sec	42	240	μA
BLE Connected 7.5 ms	4.30	0.020	mA
BLE Connected 1 sec	53	240	μA
BLE Connected 1.28 sec	48	240	μA

1. At maximum class 1 TX power, 500 ms sniff, four attempts (slave), P = 1.28s, and I = 2.56s.

2. No devices present. A 1.28 second interval with a scan window of 11.25 ms.

18. Interface Timing and AC Characteristics

18.1 SDIO/gSPI Timing

18.1.1 SDIO Default Mode Timing

SDIO default mode timing is shown by the combination of Figure 32 and Table 44.

Figure 32. SDIO Bus Timing (Default Mode)

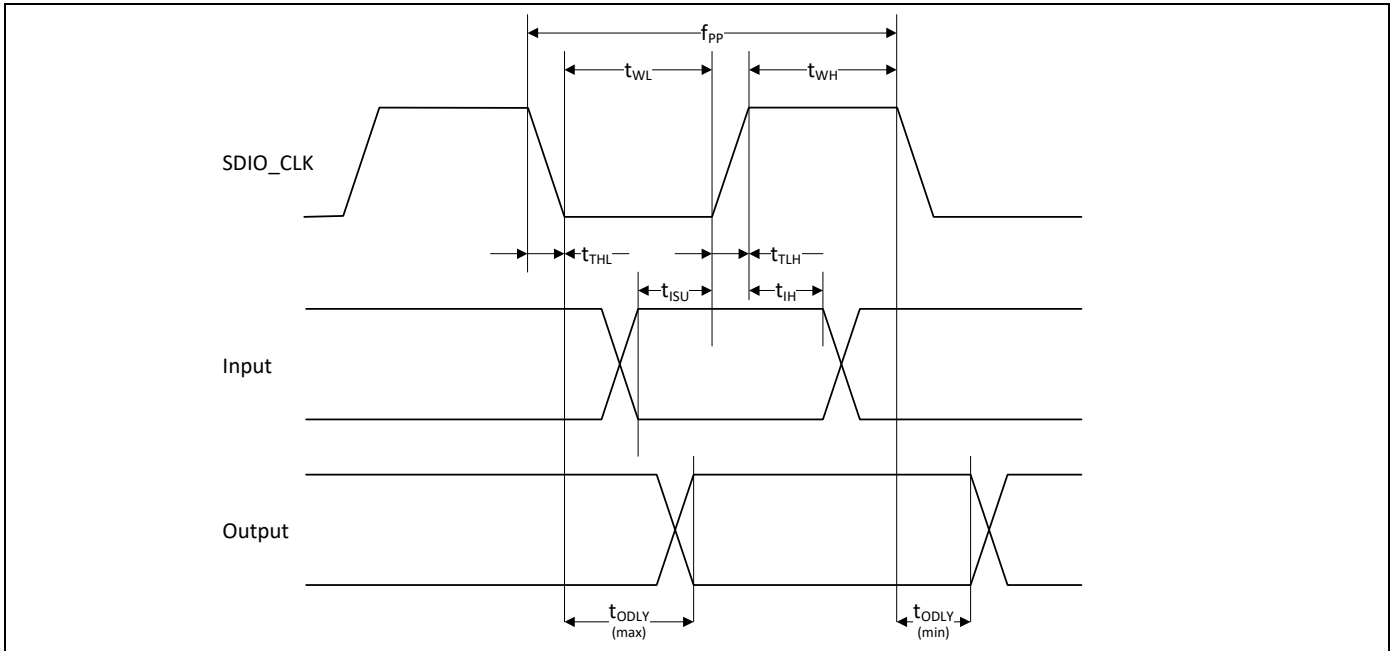

Table 44. SDIO Bus Timing¹ Parameters (Default Mode)

Parameter	Symbol	Minimum	Typical	Maximum	Unit
SDIO CLK (All values are referred to minimum V_{IH} and maximum V_{IL}²)					
Frequency – Data Transfer mode	f_{PP}	0	–	25	MHz
Frequency – Identification mode	f_{OD}	0	–	400	kHz
Clock low time	t_{WL}	10	–	–	ns
Clock high time	t_{WH}	10	–	–	ns
Clock rise time	t_{TLH}	–	–	10	ns
Clock fall time	t_{THL}	–	–	10	ns
Inputs: CMD, DAT (referenced to CLK)					
Input setup time	t_{ISU}	5	–	–	ns
Input hold time	t_{IH}	5	–	–	ns
Outputs: CMD, DAT (referenced to CLK)					
Output delay time – Data Transfer mode	t_{ODLY}	0	–	14	ns
Output delay time – Identification mode	t_{ODLY}	0	–	50	ns

1. Timing is based on $C_L \leq 40\text{pF}$ load on CMD and Data.

2. Min. (V_{ih}) = $0.7 \times V_{DDIO}$ and max (V_{il}) = $0.2 \times V_{DDIO}$.

18.1.2 SDIO High-Speed Mode Timing

SDIO high-speed mode timing is shown by the combination of Figure 33 and Table 45.

Figure 33. SDIO Bus Timing (High-Speed Mode)

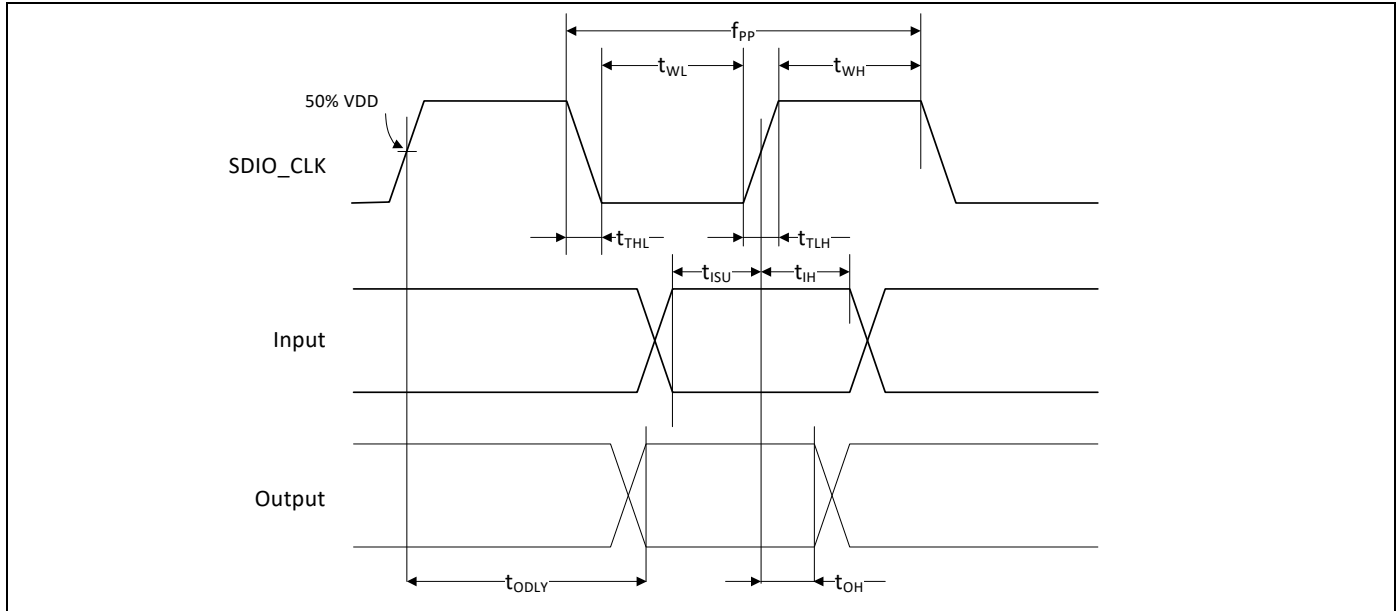

Table 45. SDIO Bus Timing¹ Parameters (High-Speed Mode)

Parameter	Symbol	Minimum	Typical	Maximum	Unit
SDIO CLK (all values are referred to minimum VIH and maximum VIL²)					
Frequency – Data Transfer Mode	f _{PP}	0	–	50	MHz
Frequency – Identification Mode	f _{OD}	0	–	400	kHz
Clock low time	t _{WL}	7	–	–	ns
Clock high time	t _{WH}	7	–	–	ns
Clock rise time	t _{TLH}	–	–	3	ns
Clock fall time	t _{THL}	–	–	3	ns
Inputs: CMD, DAT (referenced to CLK)					
Input setup time	t _{ISU}	6	–	–	ns
Input hold time	t _{IH}	2	–	–	ns
Outputs: CMD, DAT (referenced to CLK)					
Output delay time – Data Transfer Mode	t _{ODLY}	–	–	14	ns
Output hold time	t _{OH}	2.5	–	–	ns
Total system capacitance (each line)	CL	–	–	40	pF

1. Timing is based on CL ≤ 40pF load on CMD and Data.
2. Min. (V_{Ih}) = 0.7 × V_{DDIO} and max (V_{Il}) = 0.2 × V_{DDIO}.

18.1.3 SDIO Bus Timing Specifications in SDR Modes

18.1.3.1. Clock Timing

Figure 34. SDIO Clock Timing (SDR Modes)

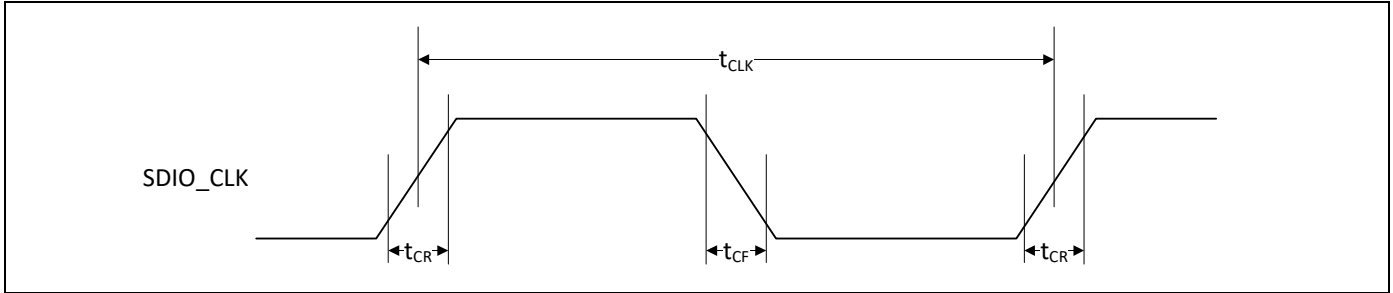

Table 46. SDIO Bus Clock Timing Parameters (SDR Modes)

Parameter	Symbol	Minimum	Maximum	Unit	Comments
–	t_{CLK}	40	–	ns	SDR12 mode
		20	–	ns	SDR25 mode
		10	–	ns	SDR50 mode
		4.8	–	ns	SDR104 mode
–	t_{CR}, t_{CF}	–	$0.2 \times t_{CLK}$	ns	$t_{CR}, t_{CF} < 2.00$ ns (max.) @100 MHz, $C_{CARD} = 10$ pF $t_{CR}, t_{CF} < 0.96$ ns (max.) @208 MHz, $C_{CARD} = 10$ pF
Clock duty cycle	–	30	70	%	–

18.1.3.2. Device Input Timing

Figure 35. SDIO Bus Input Timing (SDR Modes)

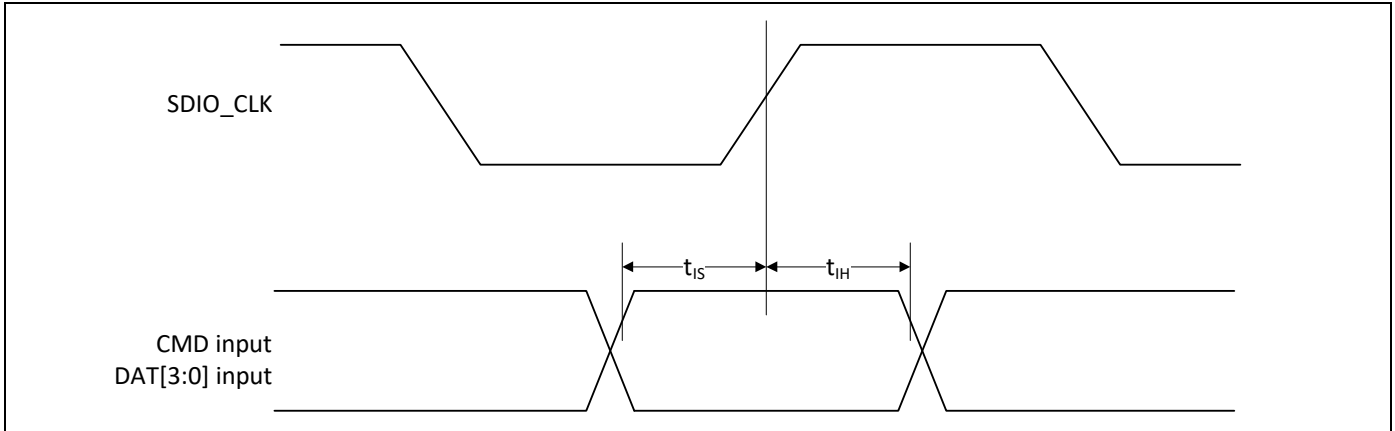

Table 47. SDIO Bus Input Timing Parameters (SDR Modes)

Symbol	Minimum	Maximum	Unit	Comments
SDR104 Mode				
t_{IS}	1.4	–	ns	$C_{CARD} = 10 \text{ pF}$, $V_{CT} = 0.975V$
t_{IH}	0.8	–	ns	$C_{CARD} = 5 \text{ pF}$, $V_{CT} = 0.975V$
SDR50 Mode				
t_{IS}	3.0	–	ns	$C_{CARD} = 10 \text{ pF}$, $V_{CT} = 0.975V$
t_{IH}	0.8	–	ns	$C_{CARD} = 5 \text{ pF}$, $V_{CT} = 0.975V$
SDR25 Mode				
t_{IS}	3.0	–	ns	$C_{CARD} = 10 \text{ pF}$, $V_{CT} = 0.975V$
t_{IH}	0.8	–	ns	$C_{CARD} = 5 \text{ pF}$, $V_{CT} = 0.975V$
SDR12 Mode				
t_{IS}	3.0	–	ns	$C_{CARD} = 10 \text{ pF}$, $V_{CT} = 0.975V$
t_{IH}	0.8	–	ns	$C_{CARD} = 5 \text{ pF}$, $V_{CT} = 0.975V$

18.1.3.3. Device Output Timing

Figure 36. SDIO Bus Output Timing (SDR Modes up to 100 MHz)

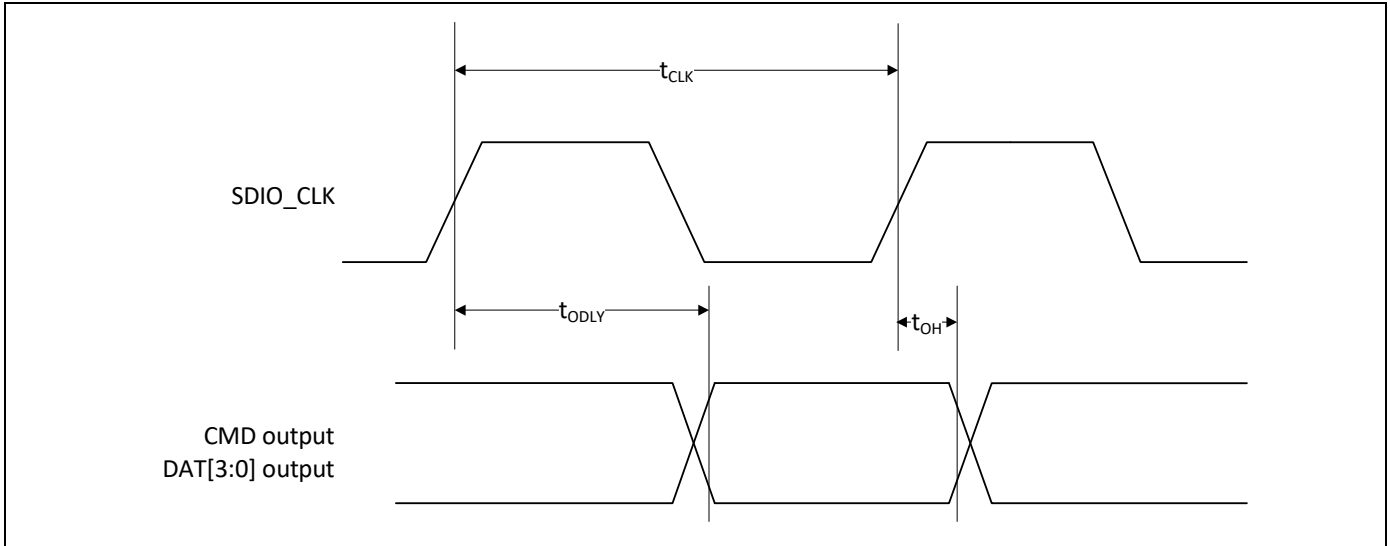

Table 48. SDIO Bus Output Timing Parameters (SDR Modes up to 100 MHz)

Symbol	Minimum	Maximum	Unit	Comments
t_{ODLY}	–	7.5	ns	$t_{CLK} \geq 10$ ns $C_L = 30$ pF using driver type B for SDR50
t_{ODLY}	–	14.0	ns	$t_{CLK} \geq 20$ ns $C_L = 40$ pF using for SDR12, SDR25
t_{OH}	1.5	–	ns	Hold time at the t_{ODLY} (min) $C_L = 15$ pF

Figure 37. SDIO Bus Output Timing (SDR Modes 100 MHz to 208 MHz)

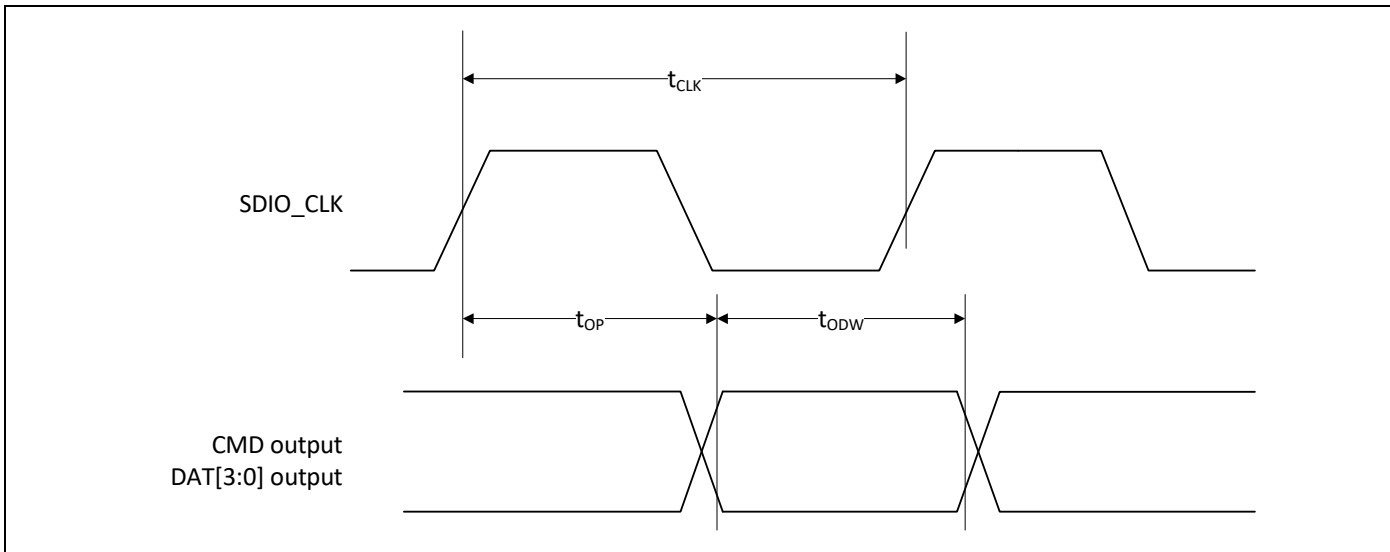
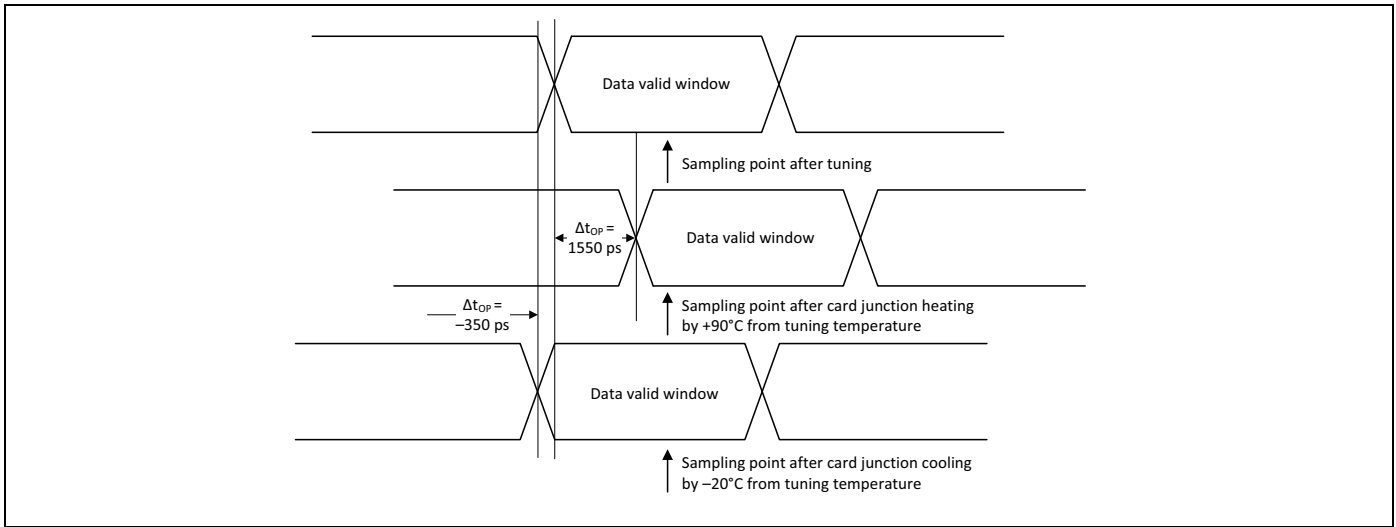

Table 49. SDIO Bus Output Timing Parameters (SDR Modes 100 MHz to 208 MHz)

Symbol	Minimum	Maximum	Unit	Comments
t_{OP}	0	2	UI	Card output phase
Δt_{OP}	-350	+1550	ps	Delay variation due to temp change after tuning
t_{ODW}	0.60	-	UI	$t_{ODW}=2.88$ ns @208 MHz

- $\Delta t_{OP} = +1550$ ps for junction temperature of $\Delta t_{OP} = 90$ degrees during operation
- $\Delta t_{OP} = -350$ ps for junction temperature of $\Delta t_{OP} = -20$ degrees during operation
- $\Delta t_{OP} = +2600$ ps for junction temperature of $\Delta t_{OP} = -20$ to $+125$ degrees during operation

Figure 38. Δt_{OP} Consideration for Variable Data Window (SDR 104 Mode)



18.1.4 SDIO Bus Timing Specifications in DDR50 Mode

Figure 39. SDIO Clock Timing (DDR50 Mode)

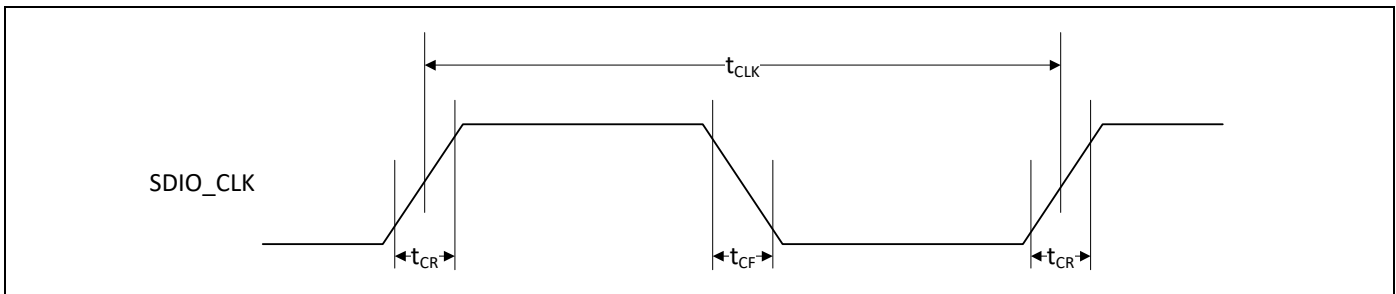

Table 50. SDIO Bus Clock Timing Parameters (DDR50 Mode)

Parameter	Symbol	Minimum	Maximum	Unit	Comments
–	t_{CLK}	20	–	ns	DDR50 mode
–	t_{CR}, t_{CF}	–	$0.2 \times t_{CLK}$	ns	$t_{CR}, t_{CF} < 4.00$ ns (max) @50 MHz, $C_{CARD} = 10$ pF
Clock duty cycle	–	45	55	%	–

18.1.4.4. Data Timing, DDR50 Mode

Figure 40. SDIO Data Timing (DDR50 Mode)

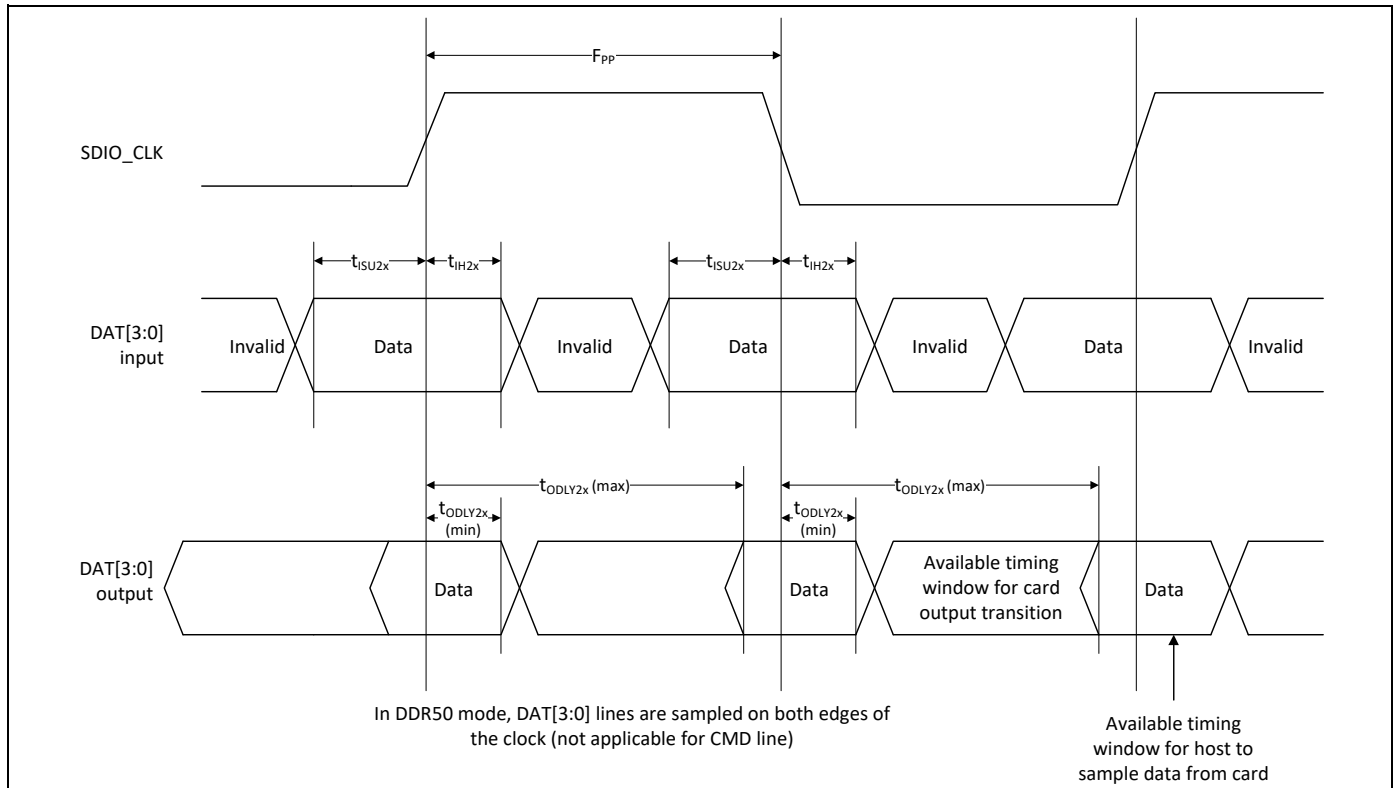

Table 51. SDIO Bus Timing Parameters (DDR50 Mode)

Parameter	Symbol	Minimum	Maximum	Unit	Comments
Input CMD					
Input setup time	t_{ISU}	6	–	ns	$C_{CARD} < 10\text{pF}$ (1 Card)
Input hold time	t_{IH}	0.8	–	ns	$C_{CARD} < 10\text{pF}$ (1 Card)
Output CMD					
Output delay time	t_{ODLY}	–	13.7	ns	$C_{CARD} < 30\text{pF}$ (1 Card)
Output hold time	t_{OH}	1.5	–	ns	$C_{CARD} < 15\text{pF}$ (1 Card)
Input DAT					
Input setup time	t_{ISU2x}	3	–	ns	$C_{CARD} < 10\text{pF}$ (1 Card)
Input hold time	t_{IH2x}	0.8	–	ns	$C_{CARD} < 10\text{pF}$ (1 Card)
Output DAT					
Output delay time	t_{ODLY2x}	–	7.0	ns	$C_{CARD} < 25\text{pF}$ (1 Card)
Output hold time	t_{OH2x}	1.5	–	ns	$C_{CARD} < 15\text{pF}$ (1 Card)

18.1.5 gSPI Signal Timing

The gSPI host and device always use the rising edge of clock to sample data.

Figure 41. gSPI Timing

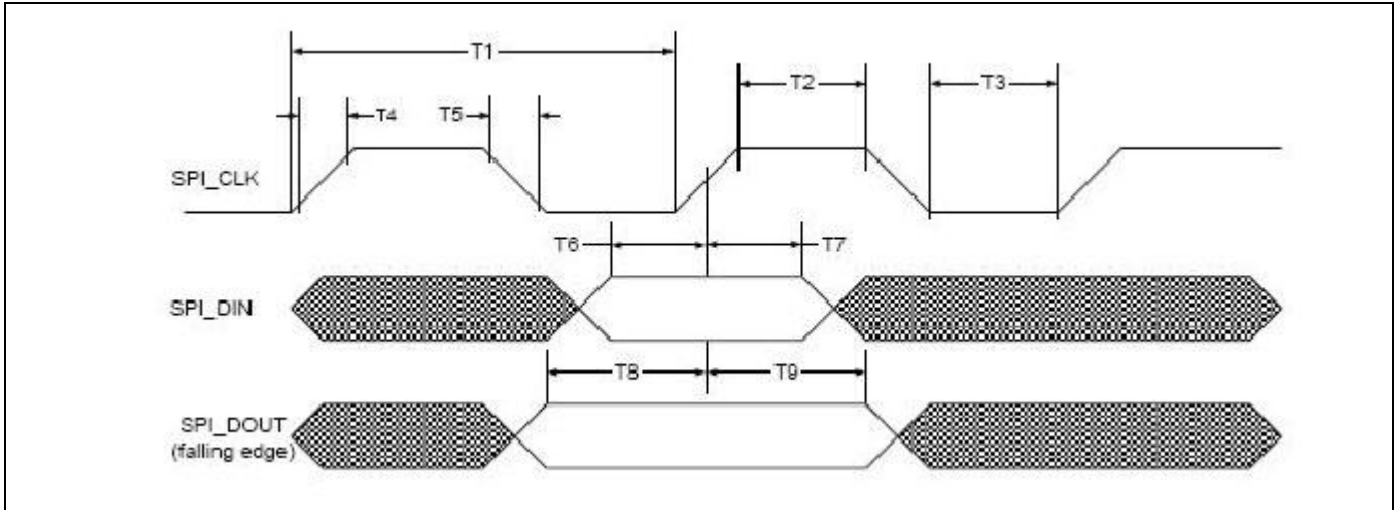

Table 52. gSPI Timing Parameters

Parameter	Symbol	Minimum	Maximum	Units	Note
Clock period	T1	20.8	–	ns	$F_{max} = 48 \text{ MHz}$
Clock high/low	T2/T3	$(0.45 \times T1) - T4$	$(0.55 \times T1) - T4$	ns	–
Clock rise/fall time ¹	T4/T5	–	2.5	ns	Measured from 10% to 90% of VDDIO
Input setup time	T6	5.0	–	ns	Setup time, SIMO valid to SPI_CLK active edge
Input hold time	T7	5.0	–	ns	Hold time, SPI_CLK active edge to SIMO invalid
Output setup time	T8	5.0	–	ns	Setup time, SOMI valid before SPI_CLK rising
Output hold time	T9	5.0	–	ns	Hold time, SPI_CLK active edge to SOMI invalid
CSX to clock ²	–	7.86	–	ns	CSX fall to 1st rising edge
Clock to CSX ^a	–	–	–	ns	Last falling edge to CSX high

- Limit applies when $SPI_CLK = F_{max}$. For slower clock speeds, longer rise/fall times are acceptable provided that the transitions are monotonic and the setup and hold time limits are complied with.
- SPI_CSx remains active for entire duration of gSPI read/write/write-read transaction (overall words for multiple-word transaction).

18.2 JTAG Timing

Table 53. JTAG Timing Characteristics

Signal Name	Period	Output Maximum	Output Minimum	Setup	Hold
TCK	125 ns	–	–	–	–
TDI	–	–	–	20 ns	0 ns
TMS	–	–	–	20 ns	0 ns
TDO	–	100 ns	0 ns	–	–
JTAG_TRST	250 ns	–	–	–	–

19. Power-Up Sequence and Timing

19.1 Sequencing of Reset and Regulator Control Signals

The CYW43353 has two signals that allow the host to control power consumption by enabling or disabling the Bluetooth, WLAN, and internal regulator blocks. These signals are described below. Additionally, diagrams are provided to indicate proper sequencing of the signals for various operational states (see Figure 42, Figure 43, and Figure 44 and Figure 45). The timing values indicated are minimum required values; longer delays are also acceptable.

19.1.1 Description of Control Signals

- **WL_REG_ON**: Used by the PMU to power up the WLAN section. It is also OR-gated with the BT_REG_ON input to control the internal CYW43353 regulators. When this pin is high, the regulators are enabled and the WLAN section is out of reset. When this pin is low the WLAN section is in reset. If both the BT_REG_ON and WL_REG_ON pins are low, the regulators are disabled.
- **BT_REG_ON**: Used by the PMU (OR-gated with WL_REG_ON) to power up the internal CYW43353 regulators. If both the BT_REG_ON and WL_REG_ON pins are low, the regulators are disabled. When this pin is low and WL_REG_ON is high, the BT section is in reset.

Note:

- For both the WL_REG_ON and BT_REG_ON pins, there should be at least a 10 ms time delay between consecutive toggles (where both signals have been driven low). This is to allow time for the CBUCK regulator to discharge. If this delay is not followed, then there may be a VDDIO in-rush current on the order of 36 mA during the next PMU cold start.
- The CYW43353 has an internal power-on reset (POR) circuit. The device will be held in reset for a maximum of 110 ms after VDDC and VDDIO have both passed the POR threshold. Wait at least 150 ms after VDDC and VDDIO are available before initiating SDIO accesses.
- VBAT should not rise 10%–90% faster than 40 microseconds. VBAT should be up before or at the same time as VDDIO. VDDIO should NOT be present first or be held high before VBAT is high.

Ensure that BT_REG_ON is driven high at the same time as or before WL_REG_ON is driven high. BT_REG_ON can be driven low 100 ms after WL_REG_ON goes high

19.1.2 Control Signal Timing Diagrams

Figure 42. WLAN = ON, Bluetooth = ON

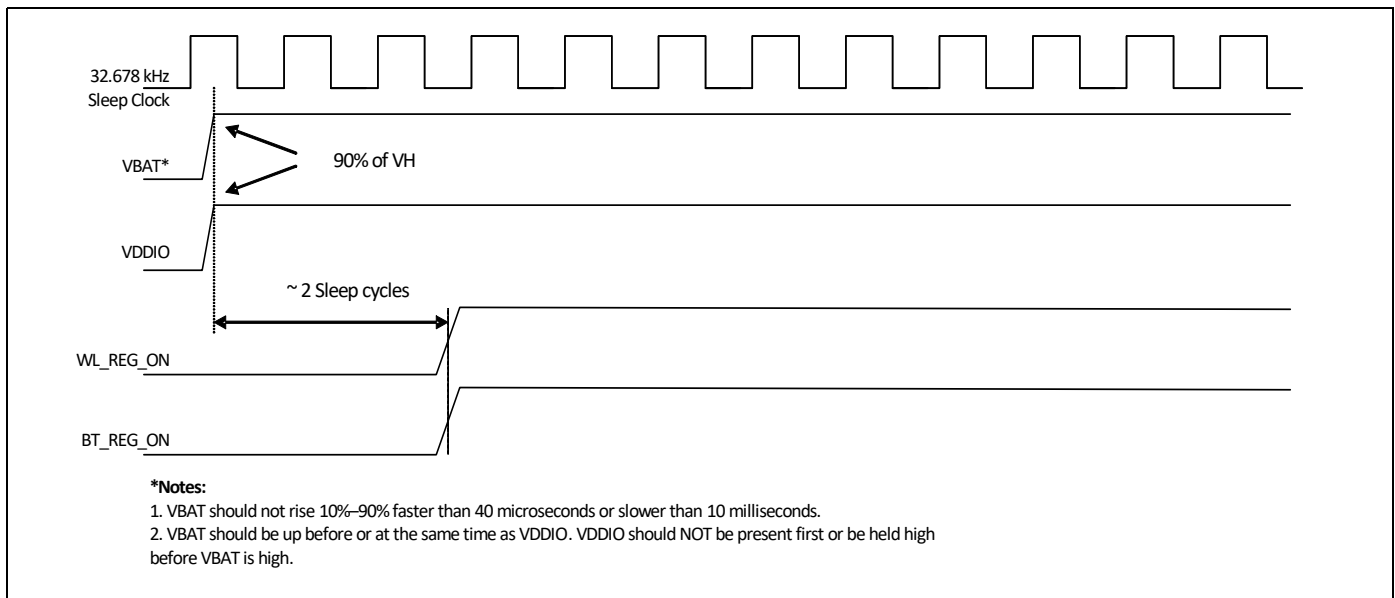

Figure 43. WLAN = OFF, Bluetooth = OFF

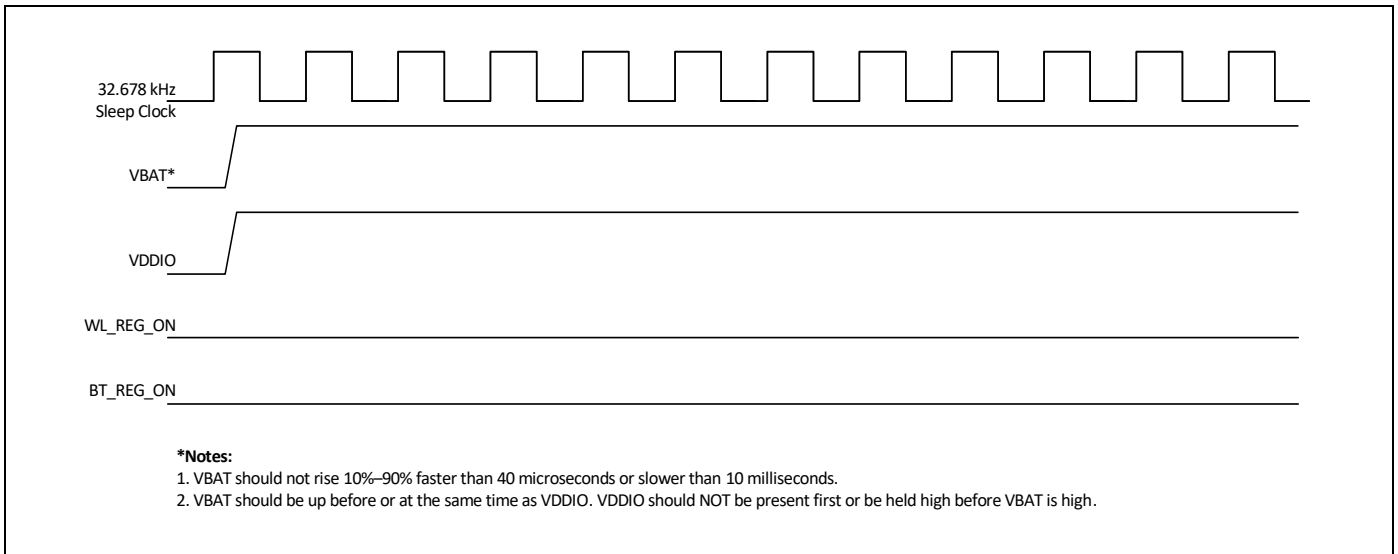

Figure 44. WLAN = ON, Bluetooth = OFF

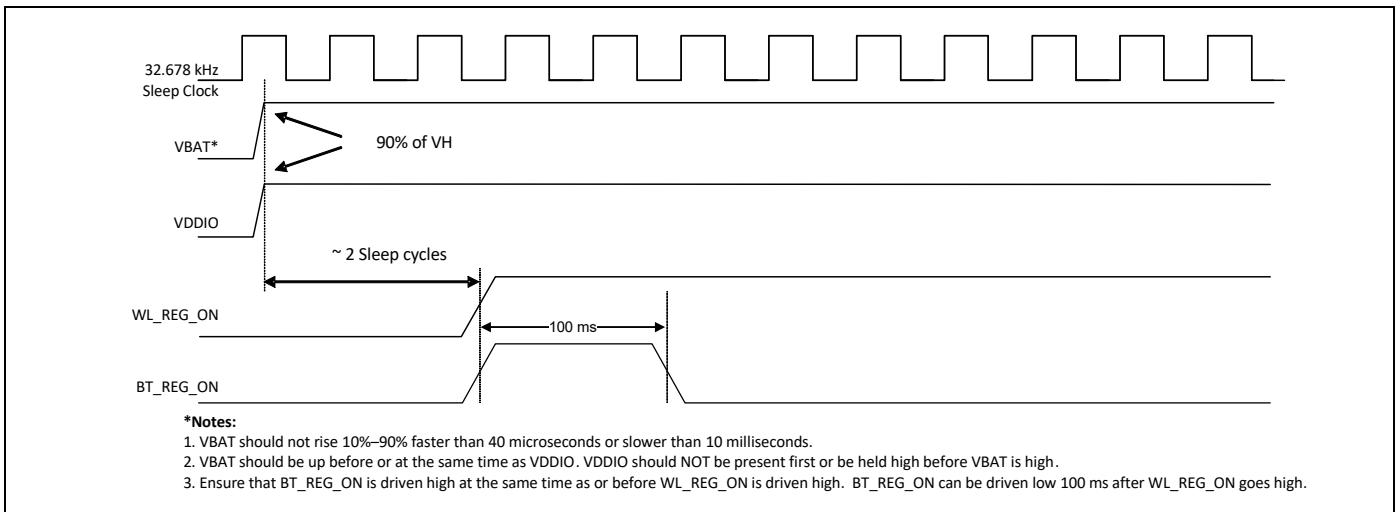
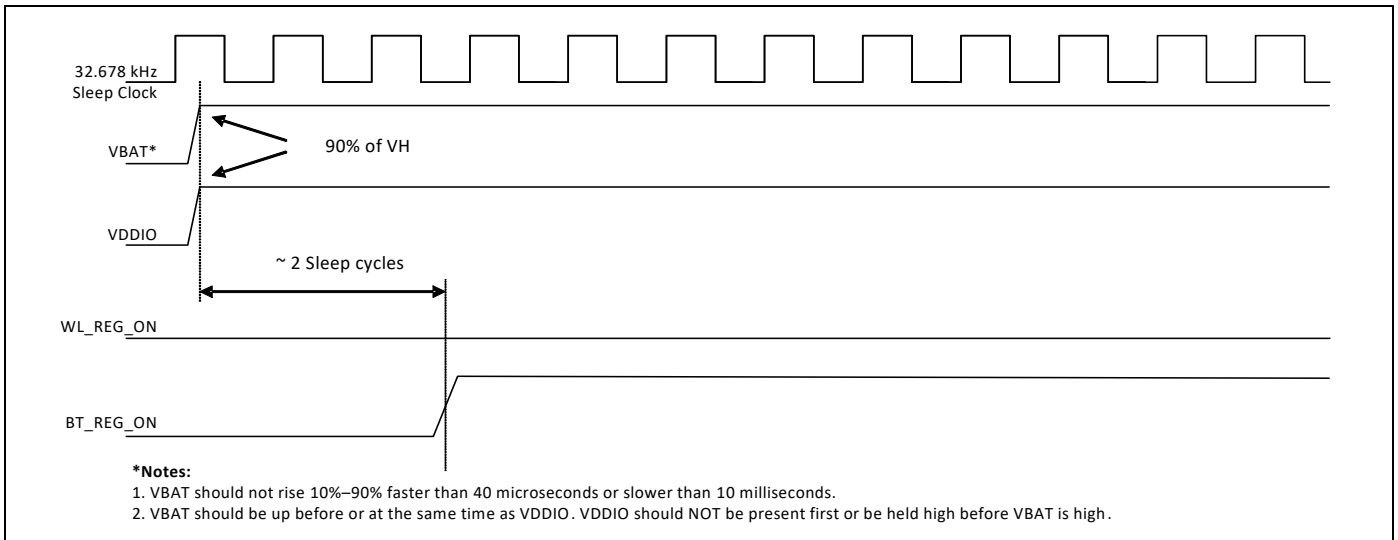

Figure 45. WLAN = OFF, Bluetooth = ON



20. Package Information

20.1 Package Thermal Characteristics

Table 54. Package Thermal Characteristics¹

Characteristic		WLBGA
θ_{JA} (°C/W) (value in still air)		32.9
θ_{JB} (°C/W)		2.56
θ_{JC} (°C/W)		0.98
ψ_{JT} (°C/W)		3.30
ψ_{JB} (°C/W)		9.85
Maximum Junction Temperature T_j (°C)		125
Maximum Power Dissipation (W)		1.119

1. No heat sink, $T_A = 70^\circ\text{C}$. This is an estimate, based on a 4-layer PCB that conforms to EIA/JESD51-7 (101.6 mm × 101.6 mm × 1.6 mm) and P = specified power maximum continuous power dissipation.

20.2 Junction Temperature Estimation and ψ_{JT} Versus θ_{JC}

Package thermal characterization parameter ψ_{JT} (ψ_{JT}) yields a better estimation of actual junction temperature (T_j) versus using the junction-to-case thermal resistance parameter θ_{JC} (θ_{JC}). The reason for this is that θ_{JC} assumes that all the power is dissipated through the top surface of the package case. In actual applications, some of the power is dissipated through the bottom and sides of the package. ψ_{JT} takes into account power dissipated through the top, bottom, and sides of the package. The equation for calculating the device junction temperature is:

$$T_J = T_T + P \times \psi_{JT}$$

Where:

- T_J = Junction temperature at steady-state condition (°C)
- T_T = Package case top center temperature at steady-state condition (°C)
- P = Device power dissipation (Watts)
- ψ_{JT} = Package thermal characteristics; no airflow (°C/W)

20.3 Environmental Characteristics

For environmental characteristics data, see [Table 24, "Environmental Ratings,"](#).

21. Mechanical Information

Figure 46. 145-Ball WLBGA Package Mechanical Information

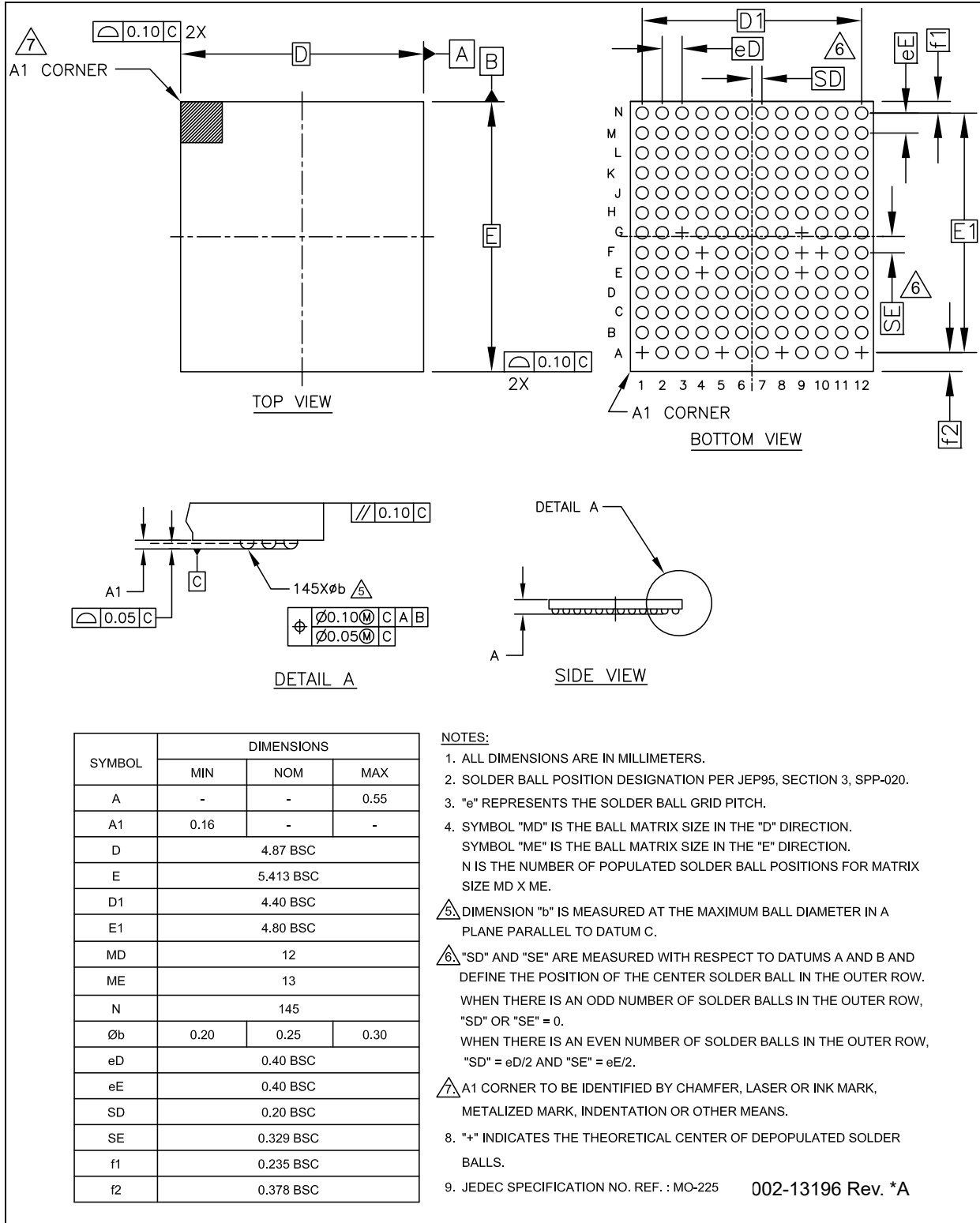
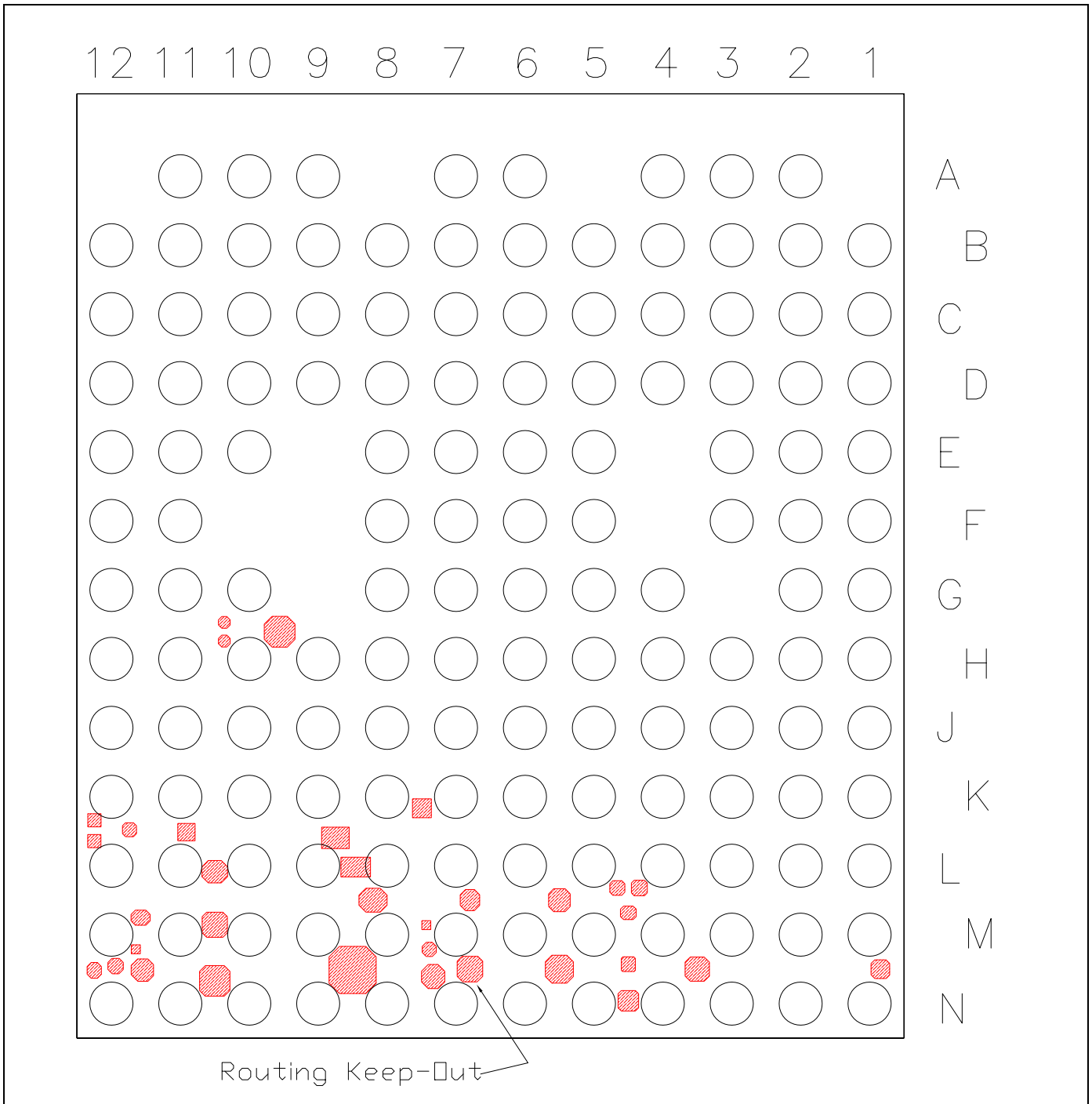

Figure 47. WLBGA Keep-out Areas for PCB Layout—Bottom View with Balls Facing Up



Note: No top-layer metal is allowed in keep-out areas.

22. Ordering Information

Part Number	Package	Description	Operating Ambient Temperature
CYW43353LIUBG	145 ball WLPGA (4.87 mm × 5.413 mm, 0.4 mm pitch)	Dual-band 2.4 GHz and 5 GHz WLAN + BT 4.1 for Automotive and Industrial Applications	−40°C to +85°C

23. Additional Information

23.1 Acronyms and Abbreviations

In most cases, acronyms and abbreviations are defined upon first use. For a more complete list of acronyms and other terms used in Cypress documents, go to: <http://www.cypress.com/glossary>.

23.2 References

The references in this section may be used in conjunction with this document.

Note: Cypress provides customer access to technical documentation and software through its <https://community.cypress.com> and Downloads & Support site (see [Additional Information](#)).

For Cypress documents, replace the “xx” in the document number with the largest number available in the repository to ensure that you have the most current version of the document.

Document (or Item) Name	Number	Source
[1] Bluetooth MWS Coexistence 2-wire Transport Interface Specification	–	wiced-smart

23.3 IoT Resources

Cypress provides a wealth of data at <http://www.cypress.com/internet-things-iot> to help you to select the right IoT device for your design, and quickly and effectively integrate the device into your design. Cypress provides customer access to a wide range of information, including technical documentation, schematic diagrams, product bill of materials, PCB layout information, and software updates. Customers can acquire technical documentation and software from the Cypress Support Community website (<https://community.cypress.com/>)

Document History Page

Document Title: CYW43353 Single-Chip 5G MAC/Baseband/Radio with Integrated Bluetooth 4.1 for Automotive and Industrial Applications			
Document Number: 002-14949			
Revision	ECN	Submission Date	Description of Change
**	-	07/02/2013	43353-DS100-R Initial release
*A	-	04/02/2014	43353-DS101-R Updated: <ul style="list-style-type: none"> • The cover page and the general features . • By deleting the HSIC interface throughout, leaving pin and signal names unchanged. • By changing the VBAT maximum voltage to 4.8V throughout. • "External Frequency Reference". • Table 2: "Crystal Oscillator and External Clock — Requirements and Performance" . • "Frequency Selection". • Figure 10: "Startup Signaling Sequence". • Figure 22: "UART Timing". • "One-Time Programmable Memory". • Table 20: "FCFBGA, WLBGA, and WLCSP Signal Descriptions," on page 117 by changing BT_VDDO to BT_VDDIO and adding a note to the GPIO pin description. • Table 31: "I/O States". • Table 34: "ESD Specifications". • Table 35: "Recommended Operating Conditions and DC Characteristics," by changing C_{IN} to C_{OUT}. • Table 36: "Bluetooth Receiver RF Specifications" by deleting what was footnote e, altering footnote b, and adding footnote b to one additional place. • Table 37: "Bluetooth Transmitter RF Specifications" • "Introduction". • RSSI accuracy in Table 42: "WLAN 2.4 GHz Receiver Performance Specifications" and Table 44: "WLAN 5 GHz Receiver Performance Specifications". • Table 43: "WLAN 2.4 GHz Transmitter Performance Specifications" and the note preceding it. • Table 45: "WLAN 5 GHz Transmitter Performance Specifications" and the note preceding it. • Section 18: "Internal Regulator Electrical Specifications" • "WLAN Current Consumption" on page 175. • Figure 65: "SDIO Bus Output Timing (SDR Modes up to 100 MHz)". • Figure 66: "SDIO Bus Output Timing (SDR Modes 100 MHz to 208 MHz)".

Document Title: CYW43353 Single-Chip 5G MAC/Baseband/Radio with Integrated Bluetooth 4.1 for Automotive and Industrial Applications			
Document Number: 002-14949			
*B	-	05/28/2014	43353-DS102-R Updated: <ul style="list-style-type: none"> The Features listed in the front matter of the document. By changing all instances of Bluetooth 4.0 to Bluetooth 4.1 throughout the document. By removing the word draft after all instances of IEEE 802.11ac throughout the document. Features. External 32.768 kHz Low-Power Oscillator. Advanced Bluetooth/WLAN Coexistence. SDIO v3.0. Table 20: "FCFBGA, WLBGA, and WLCSP Signal Descriptions," on page 25 by fixing an incorrect WLBGA ball. The second instance of M12 was changed to M10. Table 16. Table 18. Table 19. Description of Control Signals. Figure 44: "WLAN = ON, Bluetooth = OFF" .
*C	-	10/16/2014	43353-DS103-R Updated: <ul style="list-style-type: none"> Cover page.
*D	-	11/17/2014	43353-DS104-R Updated: <ul style="list-style-type: none"> The state of the data sheet from Advance Data Sheet to Data Sheet. Table 47.
*E	5449254	10/04/2016	Added Cypress Part Numbering Scheme and Mapping Table on Page 1. Updated to Cypress template.
*F	5730057	05/10/2017	Updated Cypress Logo and Copyright.
*G	6516509	04/13/2020	Updated Figure 46 (spec 002-13196 ** to *A) in Package Information .
*H	7108629	03/24/2021	Removed Cypress Part Numbering Scheme. Updated Features and 10.2.IEEE 802.11ac PHY . Updated Table 32 and Table 34 .

Sales, Solutions, and Legal Information

Worldwide Sales and Design Support

Cypress maintains a worldwide network of offices, solution centers, manufacturer's representatives, and distributors. To find the office closest to you, visit us at [Cypress Locations](#).

Products

Arm® Cortex® Microcontrollers	cypress.com/arm
Automotive	cypress.com/automotive
Clocks & Buffers	cypress.com/clocks
Interface	cypress.com/interface
Internet of Things	cypress.com/iot
Memory	cypress.com/memory
Microcontrollers	cypress.com/mcu
PSoC	cypress.com/psoc
Power Management ICs	cypress.com/pmic
Touch Sensing	cypress.com/touch
USB Controllers	cypress.com/usb
Wireless Connectivity	cypress.com/wireless

PSoC® Solutions

[PSoC 1](#) | [PSoC 3](#) | [PSoC 4](#) | [PSoC 5LP](#) | [PSoC 6 MCU](#)

Cypress Developer Community

[Community](#) | [Code Examples](#) | [Projects](#) | [Video](#) | [Blogs](#) | [Training](#) | [Components](#)

Technical Support

cypress.com/support

© Cypress Semiconductor Corporation, 2013-2021. This document is the property of Cypress Semiconductor Corporation, and Infineon Technologies company, and its affiliates ("Cypress"). This document, including any software or firmware included or referenced in this document ("Software"), is owned by Cypress under the intellectual property laws and treaties of the United States and other countries worldwide. Cypress reserves all rights under such laws and treaties and does not, except as specifically stated in this paragraph, grant any license under its patents, copyrights, trademarks, or other intellectual property rights. If the Software is not accompanied by a license agreement and you do not otherwise have a written agreement with Cypress governing the use of the Software, then Cypress hereby grants you a personal, non-exclusive, nontransferable license (without the right to sublicense) (1) under its copyright rights in the Software (a) for Software provided in source code form, to modify and reproduce the Software solely for use with Cypress hardware products, only internally within your organization, and (b) to distribute the Software in binary code form externally to end users (either directly or indirectly through resellers and distributors), solely for use on Cypress hardware product units, and (2) under those claims of Cypress's patents that are infringed by the Software (as provided by Cypress, unmodified) to make, use, distribute, and import the Software solely for use with Cypress hardware products. Any other use, reproduction, modification, translation, or compilation of the Software is prohibited.

TO THE EXTENT PERMITTED BY APPLICABLE LAW, CYPRESS MAKES NO WARRANTY OF ANY KIND, EXPRESS OR IMPLIED, WITH REGARD TO THIS DOCUMENT OR ANY SOFTWARE OR ACCOMPANYING HARDWARE, INCLUDING, BUT NOT LIMITED TO, THE IMPLIED WARRANTIES OF MERCHANTABILITY AND FITNESS FOR A PARTICULAR PURPOSE. No computing device can be absolutely secure. Therefore, despite security measures implemented in Cypress hardware or software products, Cypress shall have no liability arising out of any security breach, such as unauthorized access to or use of a Cypress product. CYPRESS DOES NOT REPRESENT, WARRANT, OR GUARANTEE THAT CYPRESS PRODUCTS, OR SYSTEMS CREATED USING CYPRESS PRODUCTS, WILL BE FREE FROM CORRUPTION, ATTACK, VIRUSES, INTERFERENCE, HACKING, DATA LOSS OR THEFT, OR OTHER SECURITY INTRUSION (collectively, "Security Breach"). Cypress disclaims any liability relating to any Security Breach, and you shall and hereby do release Cypress from any claim, damage, or other liability arising from any Security Breach. In addition, the products described in these materials may contain design defects or errors known as errata which may cause the product to deviate from published specifications. To the extent permitted by applicable law, Cypress reserves the right to make changes to this document without further notice. Cypress does not assume any liability arising out of the application or use of any product or circuit described in this document. Any information provided in this document, including any sample design information or programming code, is provided only for reference purposes. It is the responsibility of the user of this document to properly design, program, and test the functionality and safety of any application made of this information and any resulting product. "High-Risk Device" means any device or system whose failure could cause personal injury, death, or property damage. Examples of High-Risk Devices are weapons, nuclear installations, surgical implants, and other medical devices. "Critical Component" means any component of a High-Risk Device whose failure to perform can be reasonably expected to cause, directly or indirectly, the failure of the High-Risk Device, or to affect its safety or effectiveness. Cypress is not liable, in whole or in part, and you shall and hereby do release Cypress from any claim, damage, or other liability arising from any use of a Cypress product as a Critical Component in a High-Risk Device. You shall indemnify and hold Cypress, including its affiliates, and its directors, officers, employees, agents, distributors, and assigns harmless from and against all claims, costs, damages, and expenses, arising out of any claim, including claims for product liability, personal injury or death, or property damage arising from any use of a Cypress product as a Critical Component in a High-Risk Device. Cypress products are not intended or authorized for use as a Critical Component in any High-Risk Device except to the limited extent that (i) Cypress's published data sheet for the product explicitly states Cypress has qualified the product for use in a specific High-Risk Device, or (ii) Cypress has given you advance written authorization to use the product as a Critical Component in the specific High-Risk Device and you have signed a separate indemnification agreement.

Cypress, the Cypress logo, and combinations thereof, WICED, ModusToolBox, PSoC, CapSense, EZ-USB, F-RAM, and Traveo are trademarks or registered trademarks of Cypress or a subsidiary of Cypress in the United States or in other countries. For a more complete list of Cypress trademarks, visit cypress.com. Other names and brands may be claimed as property of their respective owners.

Looking for pricing, stock, or lifecycle information?

Click below to explore more details on WIN SOURCE:

 [View CYW43353LIUBGT on WIN SOURCE](#)

 [Infineon Technologies](#) Information

Optimize Your Supply Chain with WIN SOURCE Solutions

-  Global Sourcing Solution
-  Obsolete Management
-  Cost Control Management
-  Shortage Management
-  Alternative Solution
-  Excess Inventory Management