

FEATURES

High performance, low power, narrow-band transceiver
Enhanced performance ADF7021-N with external VCO
Frequency bands using external VCO: 80 MHz to 960 MHz
Improved adjacent channel power (ACP) and adjacent channel rejection (ACR) compared with the ADF7021-N
Programmable IF filter bandwidths: 9 kHz, 13.5 kHz, and 18.5 kHz
Modulation schemes: 2FSK, 3FSK, 4FSK, MSK
Spectral shaping: Gaussian and raised cosine filtering
Data rates: 0.05 kbps to 24 kbps
Power supply: 2.3 V to 3.6 V
Programmable output power: -16 dBm to +13 dBm in 63 steps
Automatic power amplifier (PA) ramp control
Receiver sensitivity
 -125 dBm at 250 bps, 2FSK
 -122 dBm at 1 kbps, 2FSK
Patent pending, on-chip image rejection calibration

On-chip fractional-N PLL
On-chip, 7-bit ADC and temperature sensor
Fully automatic frequency control (AFC) loop
Digital received signal strength indication (RSSI)
Integrated Tx/Rx switch
Leakage current in power-down mode: 0.1 μ A

APPLICATIONS

Narrow-band, short-range device (SRD) standards
ETSI EN 300 220
500 mW output power capability in 869 MHz g3 subband with external PA
High performance receiver rejection, blocking, and adjacent channel power (ACP)
FCC Part 90 (meets Emission Mask D requirements)
FCC Part 95
ARIB STD-T67
Wireless metering
Narrow-band wireless telemetry

FUNCTIONAL BLOCK DIAGRAM

Figure 1.

08635-001

Rev. B
Document Feedback

Information furnished by Analog Devices is believed to be accurate and reliable. However, no responsibility is assumed by Analog Devices for its use, nor for any infringements of patents or other rights of third parties that may result from its use. Specifications subject to change without notice. No license is granted by implication or otherwise under any patent or patent rights of Analog Devices. Trademarks and registered trademarks are the property of their respective owners.

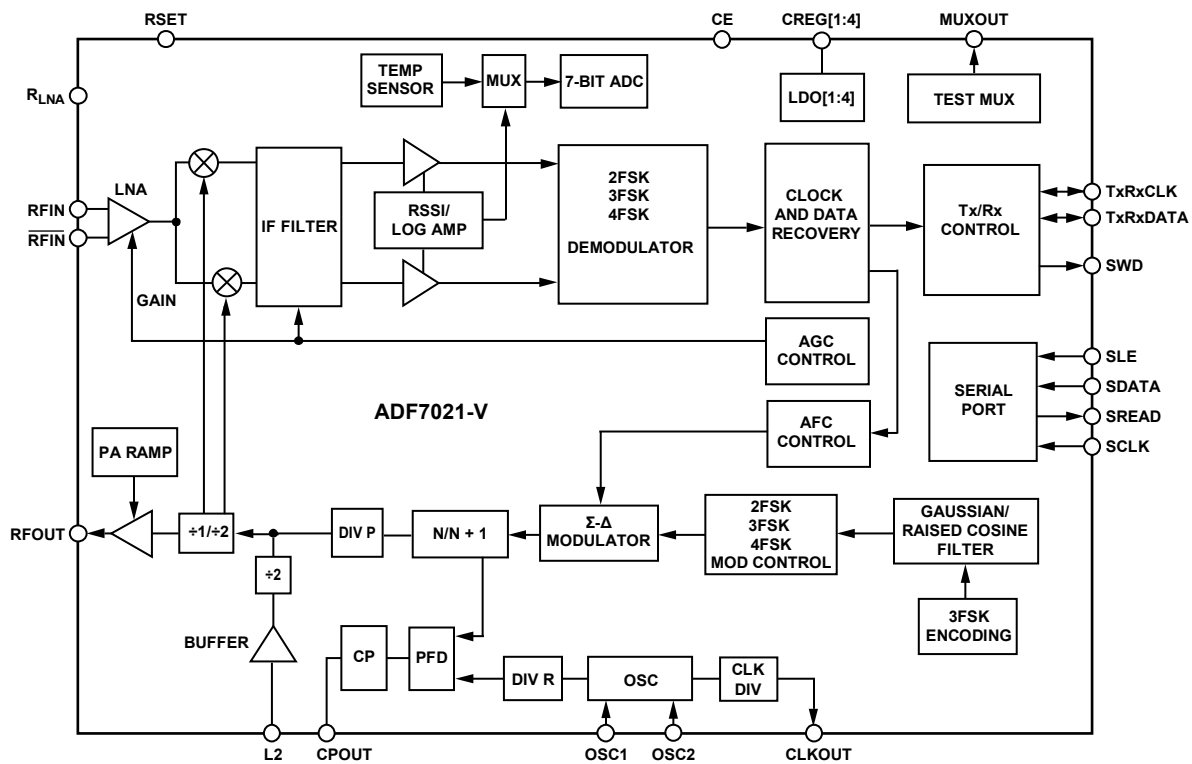
TABLE OF CONTENTS

Features	1	Demodulation, Detection, and CDR.....	31
Applications.....	1	Receiver Setup.....	33
Functional Block Diagram	1	FSK Demodulator Optimization.....	34
Revision History	3	AFC Operation.....	35
General Description.....	4	Automatic Sync Word Detection (SWD).....	36
Specifications.....	5	Applications Information.....	37
RF and PLL Specifications.....	5	IF Filter Bandwidth Calibration.....	37
Transmission Specifications.....	6	LNA/PA Matching.....	38
Receiver Specifications	7	Image Rejection Calibration.....	39
Digital Specifications	10	Packet Structure and Coding.....	40
General Specifications	11	Programming After Initial Power-Up	40
Timing Characteristics	11	Applications Circuit.....	43
Timing Diagrams.....	12	Serial Interface.....	44
Absolute Maximum Ratings.....	15	Readback Format.....	44
ESD Caution.....	15	Interfacing to a Microcontroller/DSP	45
Pin Configuration and Function Descriptions.....	16	Register 0—N Register.....	46
Typical Performance Characteristics	18	Register 1—Oscillator Register.....	47
Frequency Synthesizer	22	Register 2—Transmit Modulation Register	48
Reference Input.....	22	Register 3—Transmit/Receive Clock Register.....	49
MUXOUT.....	23	Register 4—Demodulator Setup Register	50
Voltage Controlled Oscillator (VCO).....	24	Register 5—IF Filter Setup Register.....	51
Choosing a VCO for Best System Performance.....	24	Register 6—IF Fine Calibration Setup Register	52
Transmitter.....	25	Register 7—Readback Setup Register.....	53
RF Output Stage.....	25	Register 8—Power-Down Test Register	54
Modulation Schemes.....	25	Register 9—AGC Register.....	55
Spectral Shaping.....	27	Register 10—AFC Register	56
Modulation and Filtering Options.....	28	Register 11—Sync Word Detect Register.....	57
Transmit Latency.....	28	Register 12—SWD/Threshold Setup Register.....	57
Test Pattern Generator.....	28	Register 13—3FSK/4FSK Demodulation Register.....	58
Receiver Section.....	29	Register 14—Test DAC Register.....	59
RF Front End.....	29	Register 15—Test Mode Register	60
IF Filter	29	Outline Dimensions.....	61
RSSI/AGC.....	29	Ordering Guide	61

REVISION HISTORY

9/14—Rev. A to Rev. B

Changes to Table 8 16
Change to RSSI Formula (Converting to dBm) Section 30
Change to Postdemodulator Filter Setup Section 33
Change to When to Use Fine Calibration Section 38
Change to Battery Voltage/ADCIN/Temperature Sensor
Readback Section 44
Change to Register 4—Demodulator Setup Register Section 50
Change to Register 7—Readback Setup Register Section 53
Change to Register 4—AFC Register Section 56

8/12—Rev. 0 to Rev. A

Changes to Figure 6 15
Updated Outline Dimensions 60
Changes to Ordering Guide 60

4/10—Revision 0: Initial Version

GENERAL DESCRIPTION

The **ADF7021-V** is a high performance, low power, narrow-band RF transceiver based on the **ADF7021-N**. The architecture of the **ADF7021-V** transceiver is similar to that of the **ADF7021-N** except that an external VCO is used by the on-chip RF synthesizer for applications that require improved phase noise performance.

The **ADF7021-V** is designed to operate in both the license-free ISM bands and in the licensed bands from 80 MHz to 960 MHz.

To minimize RF feedthrough and spurious emissions, the external VCO operates at 2× or 4× the desired RF frequency; the **ADF7021-V** supports a maximum VCO frequency operation of 1920 MHz. The 4× VCO operation is programmable by enabling an additional on-chip divide-by-2 outside the RF synthesizer loop and offers improved phase noise performance.

As with the **ADF7021-N** receiver, the IF filter bandwidths of 9 kHz, 13.5 kHz, and 18.5 kHz are supported, making the **ADF7021-V** ideally suited to worldwide narrow-band telemetry applications.

The part has both Gaussian and raised cosine transmit data filtering options to improve spectral efficiency for narrow-band applications. It is suitable for circuit applications targeted at the following:

- European ETSI EN 300 220
- North American FCC Part 15, Part 90, and Part 95
- Japanese ARIB STD-T67
- Korean short-range device regulations
- Chinese short-range device regulations

A complete transceiver can be built using a small number of discrete external components, making the **ADF7021-V** very suitable for area-sensitive, high performance driven applications.

The range of on-chip FSK modulation and data filtering options allows users greater flexibility in their choice of modulation schemes while meeting the tight spectral efficiency requirements. The **ADF7021-V** also supports protocols that dynamically switch among 2FSK, 3FSK, and 4FSK to maximize communication range and data throughput.

The transmit section contains a low noise fractional-N PLL with an output resolution of <1 ppm. The frequency-agile PLL allows the **ADF7021-V** to be used in frequency-hopping spread spectrum (FHSS) systems. The VCO is external, which provides better phase noise and thus lower adjacent channel power (ACP) and adjacent channel rejection (ACR) compared with the **ADF7021-N**. The VCO tuning range extends from 0.2 V to 2 V; take this range into account when choosing the external VCO.

The transmitter output power is programmable in 63 steps from -16 dBm to +13 dBm and has an automatic power amplifier ramp control to prevent spectral splatter and help meet regulatory standards. The transceiver RF frequency, channel spacing, and modulation are programmable using a simple 3-wire interface. The device operates with a power supply range of 2.3 V to 3.6 V and can be powered down when not in use.

A low IF architecture is used in the receiver (100 kHz), which minimizes power consumption and the external component count yet avoids dc offset and flicker noise at low frequencies. The IF filter has programmable bandwidths of 9 kHz, 13.5 kHz, and 18.5 kHz. The **ADF7021-V** supports a wide variety of programmable features, including Rx linearity, sensitivity, and IF bandwidth, allowing the user to trade off receiver sensitivity and selectivity against current consumption, depending on the application. The receiver also features a patented automatic frequency control (AFC) loop with programmable pull-in range that allows the PLL to remove the frequency error in the incoming signal.

The receiver achieves an image rejection performance of 50 dB using a patent-pending IR calibration scheme that does not require the use of an external RF source.

An on-chip ADC provides readback of the integrated temperature sensor, external analog input, battery voltage, and RSSI signal, which can eliminate the need for an external ADC in some applications. The temperature sensor is accurate to ±10°C over the full operating temperature range of -40°C to +85°C. This accuracy can be improved by performing a one-point calibration at room temperature and storing the result in memory.

SPECIFICATIONS

$V_{DD} = 2.3 \text{ V}$ to 3.6 V , $GND = 0 \text{ V}$, $T_A = T_{MIN}$ to T_{MAX} , unless otherwise noted. Typical specifications are at $V_{DD} = 3 \text{ V}$, $T_A = 25^\circ\text{C}$. All measurements are performed with the EVAL-ADF7021-VDBxZ using the PN9 data sequence, unless otherwise noted. The version number of ETSI EN 300 200-1 is V2.3.1. LBW = loop bandwidth and IFBW = IF filter bandwidth.

RF AND PLL SPECIFICATIONS

Table 1.

Parameter	Min	Typ	Max	Unit	Test Conditions/Comments
RF CHARACTERISTICS					
Phase Frequency Detector (PFD) Frequency	RF/256		24	MHz	Maximum usable PFD at a particular RF frequency is limited by the minimum N divider value
PHASE-LOCKED LOOP (PLL)					
Normalized In-Band Phase Noise Floor ¹		-203		dBc/Hz	
PLL Settling		155		μs	Measured for a 100 kHz frequency step to within 5 ppm accuracy, PFD = 19.68 MHz, LBW = 8 kHz
EXTERNAL VCO					
Tuning Range	0.2		2	V	
Pin L2 Input Sensitivity	0			dBm	VCO frequency < 1920 MHz
REFERENCE INPUT					
Crystal Reference ²	3.625		24	MHz	
External Oscillator ^{2,3}	3.625		24	MHz	
Crystal Start-Up Time ⁴					10 MHz XTAL, 33 pF load capacitors, $V_{DD} = 3.0 \text{ V}$
XTAL Bias = 20 μA		0.930		ms	
XTAL Bias = 35 μA		0.438		ms	
Input Level for External Oscillator					
OSC1 Pin		0.8		V p-p	Clipped sine wave
OSC2 Pin		CMOS levels		V	
ADC PARAMETERS					
Integral Nonlinearity (INL)		± 0.4		LSB	$V_{DD} = 2.3 \text{ V}$ to 3.6 V , $T_A = 25^\circ\text{C}$
Differential Nonlinearity (DNL)		± 0.4		LSB	

¹ This value can be used to calculate the in-band phase noise for any operating frequency. Use the following equation to calculate the in-band phase noise performance as seen at the power amplifier (PA) output: $-203 + 10 \log(f_{PFD}) + 20 \log N$.

² Guaranteed by design. Sample tested to ensure compliance.

³ A TCXO, VCXO, or OCXO can be used as an external oscillator.

⁴ Crystal start-up time is the time from chip enable (CE) being asserted to correct clock frequency on the CLKOUT pin.

TRANSMISSION SPECIFICATIONS

LBW = loop bandwidth.

Table 2.

Parameter	Min	Typ	Max	Unit	Test Conditions/Comments
DATA RATE					Limited by the loop bandwidth
2FSK	0.05		18.5	kbps	LBW must be $\geq 1.25 \times$ data rate for correct operation
3FSK	0.05		18.5	kbps	LBW = 18.5 kHz
4FSK	0.05		24	kbps	LBW = 18.5 kHz
MODULATION					
Frequency Deviation (f_{DEV})	0.056		28.26	kHz	PFD = 3.625 MHz
Frequency Deviation Resolution	0.306		156	kHz	PFD = 20 MHz
Gaussian Filter Bandwidth Time (BT)	56			Hz	PFD = 3.625 MHz
Raised Cosine Filter Alpha		0.5			Programmable
		0.5/0.7			
TRANSMIT POWER					
Maximum Transmit Power ¹		13		dBm	$V_{DD} = 3.0\text{ V}$, $T_A = 25^\circ\text{C}$
Transmit Power Variation vs. Temperature		± 1		dB	$T_A = -40^\circ\text{C}$ to $+85^\circ\text{C}$
Transmit Power Variation vs. V_{DD}		± 1		dB	$V_{DD} = 2.3\text{ V}$ to 3.6 V at 915 MHz, $T_A = 25^\circ\text{C}$
Transmit Power Flatness		± 1		dB	902 MHz to 928 MHz, $V_{DD} = 3\text{ V}$, $T_A = 25^\circ\text{C}$
Programmable Step Size		0.3125		dB	-16 dBm to +13 dBm
ADJACENT CHANNEL POWER (ACP)					Gaussian 2FSK modulation, 13 dBm output power, PFD = 19.68 MHz, LBW = 6 kHz
460 MHz					
12.5 kHz Channel Spacing		-47		dBm	Measured in a $\pm 8.5\text{ kHz}$ bandwidth at $\pm 12.5\text{ kHz}$ offset, 2.4 kbps PN9 data, $f_{DEV} = 1.2\text{ kHz}$
25 kHz Channel Spacing		-53		dBm	Measured in a $\pm 16\text{ kHz}$ bandwidth at $\pm 25\text{ kHz}$ offset, 4.8 kbps PN9 data, $f_{DEV} = 2.4\text{ kHz}$
868 MHz					Compliant with ETSI EN 300 220
12.5 kHz Channel Spacing		-44		dBm	Measured in a $\pm 8.5\text{ kHz}$ bandwidth at $\pm 12.5\text{ kHz}$ offset, 2.4 kbps PN9 data, $f_{DEV} = 1.2\text{ kHz}$
25 kHz Channel Spacing		-49		dBm	Measured in a $\pm 16\text{ kHz}$ bandwidth at $\pm 25\text{ kHz}$ offset, 4.8 kbps PN9 data, $f_{DEV} = 2.4\text{ kHz}$
MODULATION BANDWIDTH					869.525 MHz, Gaussian 2FSK modulation, 4.8 kbps, $f_{DEV} = 2.4\text{ kHz}$, 10 dBm output power, ² compliant with ETSI EN 300 220, LBW = 6 kHz
125 kHz Offset		-74.5		dBm/1 kHz	
125 kHz + 200 kHz		-79		dBm/1 kHz	
125 kHz + 400 kHz		-69.5		dBm/10 kHz	
125 kHz + 1 MHz		-62		dBm/100 kHz	
EMISSION MASK					FCC Part 90 Emission Mask D, 100 Hz resolution bandwidth, Gaussian 2FSK modulation, LBW = 6 kHz, 10 dBm output power, 2.4 kbps PN9 data, $f_{DEV} = 1.2\text{ kHz}$
12.5 kHz Offset					
460 MHz		-77		dBc	
OCCUPIED BANDWIDTH					99.0% of total mean power, LBW = 6 kHz, 10 dBm output power
2FSK, Gaussian Data Filtering					
12.5 kHz Channel Spacing		4.0		kHz	2.4 kbps PN9 data, $f_{DEV} = 1.2\text{ kHz}$
25 kHz Channel Spacing		8.5		kHz	4.8 kbps PN9 data, $f_{DEV} = 2.4\text{ kHz}$
2FSK, Raised Cosine Data Filtering					
12.5 kHz Channel Spacing		4.5		kHz	2.4 kbps PN9 data, $f_{DEV} = 1.2\text{ kHz}$
25 kHz Channel Spacing		9.6		kHz	4.8 kbps PN9 data, $f_{DEV} = 2.4\text{ kHz}$

Parameter	Min	Typ	Max	Unit	Test Conditions/Comments
3FSK, Raised Cosine Filtering 12.5 kHz Channel Spacing		4.3		kHz	2.4 kbps PN9 data, $f_{DEV} = 1.2$ kHz
25 kHz Channel Spacing		8.5		kHz	4.8 kbps PN9 data, $f_{DEV} = 2.4$ kHz
4FSK, Raised Cosine Filtering 25 kHz Channel Spacing		11.3		kHz	9.6 kbps PN9 data, $f_{DEV} = 1.2$ kHz
SPURIOUS EMISSIONS					
Reference Spurs		-65		dBc	LBW = 8 kHz
HARMONICS ³					13 dBm output power
Second Harmonic		-35/-52		dBc	Unfiltered conductive/filtered conductive
Third Harmonic		-43/-60		dBc	Unfiltered conductive/filtered conductive
All Other Harmonics		-36/-65		dBc	Unfiltered conductive/filtered conductive
OPTIMUM PA LOAD IMPEDANCE					
$f_{RF} = 915$ MHz		39 + j61		Ω	
$f_{RF} = 868$ MHz		48 + j54		Ω	
$f_{RF} = 470$ MHz		97.5 + j64.4		Ω	
$f_{RF} = 450$ MHz		98 + j65		Ω	
$f_{RF} = 426$ MHz		100 + j65		Ω	
$f_{RF} = 315$ MHz		129 + j63		Ω	
$f_{RF} = 175$ MHz		173 + j49		Ω	
$f_{RF} = 169$ MHz		74.5 + j48.5		Ω	

¹ Measured as maximum unmodulated power.

² Suitable for ETSI 500 mW Tx requirements.

³ Conductive filtered harmonic emissions measured on the EVAL-ADF7021-VDBxZ, which includes a T-stage harmonic filter (two inductors and one capacitor).

RECEIVER SPECIFICATIONS

LBW = loop bandwidth and IFBW = IF filter bandwidth.

Table 3.

Parameter	Min	Typ	Max	Unit	Test Conditions/Comments
DATA RATE					Limited by the IF filter bandwidth ¹
2FSK	0.05		9.0	kbps	IFBW = 9 kHz
	0.05		13.5	kbps	IFBW = 13.5 kHz
	0.05		18.5	kbps	IFBW = 18.5 kHz
3FSK	0.05		18.5	kbps	IFBW = 18.5 kHz
4FSK	0.05		24	kbps	IFBW = 18.5 kHz
SENSITIVITY					Bit error rate (BER) = 10^{-3}
2FSK					
Sensitivity at 0.25 kbps		-125		dBm	$f_{DEV} = 1$ kHz, high sensitivity mode, IFBW = 9.0 kHz
Sensitivity at 1 kbps		-122		dBm	$f_{DEV} = 1$ kHz, high sensitivity mode, IFBW = 9.0 kHz
Sensitivity at 2.4 kbps		-119		dBm	$f_{DEV} = 1.2$ kHz, high sensitivity mode, IFBW = 9.0 kHz
Sensitivity at 4.8 kbps		-116		dBm	$f_{DEV} = 2.4$ kHz, high sensitivity mode, IFBW = 9.0 kHz
Sensitivity at 9.6 kbps		-114		dBm	$f_{DEV} = 4.8$ kHz, high sensitivity mode, IFBW = 18.5 kHz
Gaussian 2FSK					
Sensitivity at 0.25 kbps		-125		dBm	$f_{DEV} = 1$ kHz, high sensitivity mode, IFBW = 9.0 kHz
Sensitivity at 1 kbps		-122		dBm	$f_{DEV} = 1$ kHz, high sensitivity mode, IFBW = 9.0 kHz
Sensitivity at 2.4 kbps		-120		dBm	$f_{DEV} = 1.2$ kHz, high sensitivity mode, IFBW = 9.0 kHz
Sensitivity at 4.8 kbps		-117		dBm	$f_{DEV} = 2.4$ kHz, high sensitivity mode, IFBW = 9.0 kHz
Sensitivity at 9.6 kbps		-114		dBm	$f_{DEV} = 4.8$ kHz, high sensitivity mode, IFBW = 18.5 kHz
GMSK					
Sensitivity at 4.8 kbps		-114.5		dBm	$f_{DEV} = 1.2$ kHz, high sensitivity mode, IFBW = 9.0 kHz

Parameter	Min	Typ	Max	Unit	Test Conditions/Comments
Raised Cosine 2FSK					
Sensitivity at 0.25 kbps		-125		dBm	$f_{DEV} = 1$ kHz, high sensitivity mode, IFBW = 9.0 kHz
Sensitivity at 1 kbps		-121		dBm	$f_{DEV} = 1$ kHz, high sensitivity mode, IFBW = 9.0 kHz
Sensitivity at 2.4 kbps		-120		dBm	$f_{DEV} = 1.2$ kHz, high sensitivity mode, IFBW = 9.0 kHz
Sensitivity at 4.8 kbps		-115		dBm	$f_{DEV} = 2.4$ kHz, high sensitivity mode, IFBW = 9.0 kHz
Sensitivity at 9.6 kbps		-114		dBm	$f_{DEV} = 4.8$ kHz, high sensitivity mode, IFBW = 18.5 kHz
3FSK					
Sensitivity at 4.8 kbps		-110		dBm	$f_{DEV} = 2.4$ kHz, high sensitivity mode, IFBW = 18.5 kHz, Viterbi detection on
Raised Cosine 3FSK					
Sensitivity at 4.8 kbps		-110		dBm	$f_{DEV} = 2.4$ kHz, high sensitivity mode, IFBW = 13.5 kHz, alpha = 0.5, Viterbi detection on
4FSK					
Sensitivity at 4.8 kbps		-112		dBm	$f_{DEV} (inner)^2 = 1.2$ kHz, high sensitivity mode, IFBW = 13.5 kHz
Raised Cosine 4FSK					
Sensitivity at 4.8 kbps		-109		dBm	$f_{DEV} (inner)^2 = 1.2$ kHz, high sensitivity mode, IFBW = 13.5 kHz, alpha = 0.5
INPUT IP3					Two-tone test, $f_{LO} = 860$ MHz, $f_1 = f_{LO} + 100$ kHz, $f_2 = f_{LO} - 800$ kHz
Low Gain, Enhanced Linearity Mode		-3		dBm	LNA_GAIN = 3, MIXER_LINEARITY = 1
Medium Gain Mode		-13.5		dBm	LNA_GAIN = 10, MIXER_LINEARITY = 0
High Sensitivity Mode		-24		dBm	LNA_GAIN = 30, MIXER_LINEARITY = 0
ADJACENT CHANNEL REJECTION (ACR)					
868 MHz					Desired signal is 3 dB above the sensitivity point of -109.5 dBm as per EN 300 220; rejection is measured as the level of an unmodulated interferer to cause a BER of 10^{-2} for the desired signal
12.5 kHz Channel Spacing		-60		dBm	IFBW = 9 kHz, data rate = 0.25 kbps, $f_{DEV} = 1$ kHz, LBW = 6 kHz
25 kHz Channel Spacing		-39		dBm	IFBW = 9 kHz, data rate = 0.25 kbps, $f_{DEV} = 1$ kHz, LBW = 6 kHz
12.5 kHz Channel Spacing		-60		dBm	IFBW = 9 kHz, data rate = 1 kbps, $f_{DEV} = 1$ kHz, LBW = 6 kHz
25 kHz Channel Spacing		-40		dBm	IFBW = 9 kHz, data rate = 1 kbps, $f_{DEV} = 1$ kHz, LBW = 6 kHz
12.5 kHz Channel Spacing		-59.5		dBm	IFBW = 9 kHz, data rate = 2.4 kbps, $f_{DEV} = 1.2$ kHz, LBW = 6 kHz
25 kHz Channel Spacing		-42		dBm	IFBW = 9 kHz, data rate = 2.4 kbps, $f_{DEV} = 1.2$ kHz, LBW = 6 kHz
12.5 kHz Channel Spacing		-63		dBm	IFBW = 9 kHz, data rate = 4.8 kbps, $f_{DEV} = 2.4$ kHz, LBW = 6 kHz
25 kHz Channel Spacing		-45		dBm	IFBW = 9 kHz, data rate = 4.8 kbps, $f_{DEV} = 2.4$ kHz, LBW = 6 kHz
25 kHz Channel Spacing		-57		dBm	IFBW = 18.5 kHz, data rate = 9.6 kbps, $f_{DEV} = 4.8$ kHz, LBW = 6 kHz
460 MHz					Desired signal is at -106.5 dBm; rejection is measured as the level of an unmodulated interferer to cause a BER of 10^{-2} for the desired signal
12.5 kHz Channel Spacing		-59.5		dBm	IFBW = 9 kHz, data rate = 0.25 kbps, $f_{DEV} = 1$ kHz, LBW = 6 kHz
25 kHz Channel Spacing		-37.5		dBm	IFBW = 9 kHz, data rate = 0.25 kbps, $f_{DEV} = 1$ kHz, LBW = 6 kHz
12.5 kHz Channel Spacing		-60		dBm	IFBW = 9 kHz, data rate = 1 kbps, $f_{DEV} = 1$ kHz, LBW = 6 kHz
25 kHz Channel Spacing		-41		dBm	IFBW = 9 kHz, data rate = 1 kbps, $f_{DEV} = 1$ kHz, LBW = 6 kHz
12.5 kHz Channel Spacing		-62		dBm	IFBW = 9 kHz, data rate = 2.4 kbps, $f_{DEV} = 1.2$ kHz, LBW = 6 kHz
25 kHz Channel Spacing		-43		dBm	IFBW = 9 kHz, data rate = 2.4 kbps, $f_{DEV} = 1.2$ kHz, LBW = 6 kHz
12.5 kHz Channel Spacing		-61.5		dBm	IFBW = 9 kHz, data rate = 4.8 kbps, $f_{DEV} = 2.4$ kHz, LBW = 6 kHz
25 kHz Channel Spacing		-44.5		dBm	IFBW = 9 kHz, data rate = 4.8 kbps, $f_{DEV} = 2.4$ kHz, LBW = 6 kHz
25 kHz Channel Spacing		-56		dBm	IFBW = 18.5 kHz, data rate = 9.6 kbps, $f_{DEV} = 4.8$ kHz, LBW = 6 kHz
COCHANNEL REJECTION					Desired signal is 3 dB above the sensitivity point of -109.5 dBm; rejection is measured as the level of an interferer to cause a BER of 10^{-2} for the desired signal
868 MHz		-5		dB	IFBW = 9 kHz, data rate = 4.8 kbps, $f_{DEV} = 2.4$ kHz, LBW = 6 kHz

Parameter	Min	Typ	Max	Unit	Test Conditions/Comments
IMAGE CHANNEL REJECTION					Desired signal (2FSK, 9.6 kbps, ± 4 kHz deviation) is 3 dB above the sensitivity point ($BER = 10^{-2}$); modulated interferer (2FSK, 9.6 kbps, ± 4 kHz deviation) is placed at the image frequency of $f_{RF} - 200$ kHz; the interferer level is increased until $BER = 10^{-2}$
868 MHz		26/39		dB	Uncalibrated/calibrated, ³ $V_{DD} = 3.0$ V, $T_A = 25^\circ\text{C}$
460 MHz		29/50		dB	Uncalibrated/calibrated, ³ $V_{DD} = 3.0$ V, $T_A = 25^\circ\text{C}$
BLOCKING					Desired signal is 3 dB above the sensitivity point of -109.5 dBm; rejection is measured as the level of an unmodulated interferer to cause a BER of 10^{-2} for the desired signal; as per ETSI EN 300 220-1
± 1 MHz		-29.5		dBm	
± 2 MHz		-26.5		dBm	
± 5 MHz		-26		dBm	
± 10 MHz		-25.5		dBm	
SATURATION (MAXIMUM INPUT LEVEL)		12		dBm	2FSK mode, $BER = 10^{-3}$
RECEIVED SIGNAL STRENGTH INDICATION (RSSI)					
Input Power Range ⁴		-120 to -47		dBm	Input power range = -100 dBm to -47 dBm
Linearity		± 2		dB	Input power range = -100 dBm to -47 dBm
Absolute Accuracy		± 3		dB	Input power range = -100 dBm to -47 dBm
Response Time		333		μs	As per AGC gain stage, AGC clock = 3 kHz
AUTOMATIC FREQUENCY LOOP (AFC)					
Pull-In Range, Minimum		0.5		kHz	Range is programmable in Register 10 (Bits[DB31:DB24])
Pull-In Range, Maximum		$1.5 \times IF_FILTER_BW$		kHz	Range is programmable in Register 10 (Bits[DB31:DB24])
Response Time		96		Bits	Dependent on modulation index
Accuracy		0.5		kHz	Input power range = -100 dBm to $+12$ dBm
Rx SPURIOUS EMISSIONS ⁵					
External 920 MHz VCO		$-54/-88$		dBm	< 1 GHz at antenna input, unfiltered conductive/filtered conductive
External 920 MHz VCO		$-45/-66$		dBm	> 1 GHz at antenna input, unfiltered conductive/filtered conductive
External 1738 MHz VCO		$-85/-85$		dBm	< 1 GHz at antenna input, unfiltered conductive/filtered conductive
External 1738 MHz VCO		$-39/-52$		dBm	> 1 GHz at antenna input, unfiltered conductive/filtered conductive
LNA INPUT IMPEDANCE					RFIN to RFGND; refer to the AN-859 Application Note for other frequencies
$f_{RF} = 915$ MHz		$24 - j60$		Ω	
$f_{RF} = 868$ MHz		$26 - j63$		Ω	
$f_{RF} = 470$ MHz		$58 - j124$		Ω	
$f_{RF} = 450$ MHz		$63 - j129$		Ω	
$f_{RF} = 426$ MHz		$68 - j134$		Ω	
$f_{RF} = 315$ MHz		$96 - j160$		Ω	
$f_{RF} = 175$ MHz		$178 - j190$		Ω	
$f_{RF} = 169$ MHz		$182.5 - j194$		Ω	

¹ Using Gaussian or raised cosine filtering. Choose the frequency deviation to ensure that the transmit-occupied signal bandwidth is within the receiver IF filter bandwidth.

² 4FSK f_{DEV} is defined as the frequency spacing from the RF carrier to $+f_{DEV}$ or $-f_{DEV}$. It is also equal to half the frequency spacing between adjacent symbols.

³ Calibration of the image rejection used an external RF source.

⁴ For received signal levels < -100 dBm, it is recommended that the RSSI readback value be averaged over a number of samples to improve RSSI accuracy at low input power.

⁵ Filtered conductive receive spurious emissions are measured on the EVAL-ADF7021-VDBxZ, which includes a T-stage harmonic filter (two inductors and one capacitor).

DIGITAL SPECIFICATIONS

Table 4.

Parameter	Min	Typ	Max	Unit	Test Conditions/Comments
TIMING INFORMATION					
Chip Enabled to Regulator Ready		50		μs	CREG[1:4] = 100 nF
Chip Enabled to Tx Mode					32-bit register write time = 50 μs
TCXO Reference		1		ms	Depends on VCO settling
XTAL		2		ms	Depends on VCO settling
Chip Enabled to Rx Mode					32-bit register write time = 50 μs , IF filter coarse calibration only
TCXO Reference		1.2		ms	Depends on VCO settling
XTAL		2.2		ms	Depends on VCO settling
Tx-to-Rx Turnaround Time		AGC settling + (5 \times t _{BIT})		ms	Time to synchronized data output; includes AGC settling (three AGC levels) and CDR synchronization; t _{BIT} = data bit period; AFC settling not included
LOGIC INPUTS					
Input High Voltage, V _{INH}	0.7 \times V _{DD}			V	
Input Low Voltage, V _{INL}			0.2 \times V _{DD}	V	
Input Current, I _{INH} /I _{INL}			± 1	μA	
Input Capacitance, C _{IN}			10	pF	
Control Clock Input			50	MHz	
LOGIC OUTPUTS					
Output High Voltage, V _{OH}	V _{DD2} – 0.4			V	I _{OH} = 500 μA
Output Low Voltage, V _{OL}			0.4	V	I _{OL} = 500 μA
CLKOUT Rise/Fall Time			5	ns	
CLKOUT Load			10	pF	

GENERAL SPECIFICATIONS

Table 5.

Parameter	Min	Typ	Max	Unit	Test Conditions/Comments
TEMPERATURE RANGE (T _A)	-40		+85	°C	
POWER SUPPLIES					
Voltage Supply, V _{DD}	2.3		3.6	V	All VDDx pins must be tied together
TRANSMIT CURRENT CONSUMPTION ^{1, 2}					V _{DD} = 3.0 V, PA is matched into 50 Ω
868 MHz					
0 dBm		17.6		mA	
5 dBm		20.8		mA	
10 dBm		27.1		mA	
460 MHz					
0 dBm		13.8		mA	
5 dBm		17		mA	
10 dBm		23		mA	
RECEIVE CURRENT CONSUMPTION ²					V _{DD} = 3.0 V
868 MHz					
Low Current Mode		19.3		mA	
High Sensitivity Mode		21.7		mA	
460 MHz					
Low Current Mode		16.3		mA	
High Sensitivity Mode		18.3		mA	
POWER-DOWN CURRENT CONSUMPTION ²					
Low Power Sleep Mode		0.1	1	μA	CE low

¹ The transmit current consumption tests used the same combined PA and LNA matching network as that used on the EVAL-ADF7021-VDBxZ evaluation boards. Improved PA efficiency is achieved by using a separate PA matching network.

² Device current only. VCO and TCXO currents are excluded.

TIMING CHARACTERISTICS

V_{DD} = 3 V ± 10%, GND = 0 V, T_A = 25°C, unless otherwise noted. Guaranteed by design but not production tested.

Table 6.

Parameter	Limit at T _{MIN} to T _{MAX}	Unit	Description
t ₁	>10	ns	SDATA to SCLK setup time
t ₂	>10	ns	SDATA to SCLK hold time
t ₃	>25	ns	SCLK high duration
t ₄	>25	ns	SCLK low duration
t ₅	>10	ns	SCLK to SLE setup time
t ₆	>20	ns	SLE pulse width
t ₈	<25	ns	SCLK to SREAD data valid, readback
t ₉	<25	ns	SREAD hold time after SCLK, readback
t ₁₀	>10	ns	SCLK to SLE disable time, readback
t ₁₁	5 < t ₁₁ < (1/4 × t _{BIT})	ns	TxRxCLK negative edge to SLE
t ₁₂	>5	ns	TxRxDATA to TxRxCLK setup time (Tx mode)
t ₁₃	>5	ns	TxRxCLK to TxRxDATA hold time (Tx mode)
t ₁₄	5 < t ₁₄ < (1/4 × t _{BIT})	μs	TxRxCLK negative edge to SLE
t ₁₅	>1/4 × t _{BIT}	μs	SLE positive edge to positive edge of TxRxCLK (Rx mode)

TIMING DIAGRAMS

Serial Interface

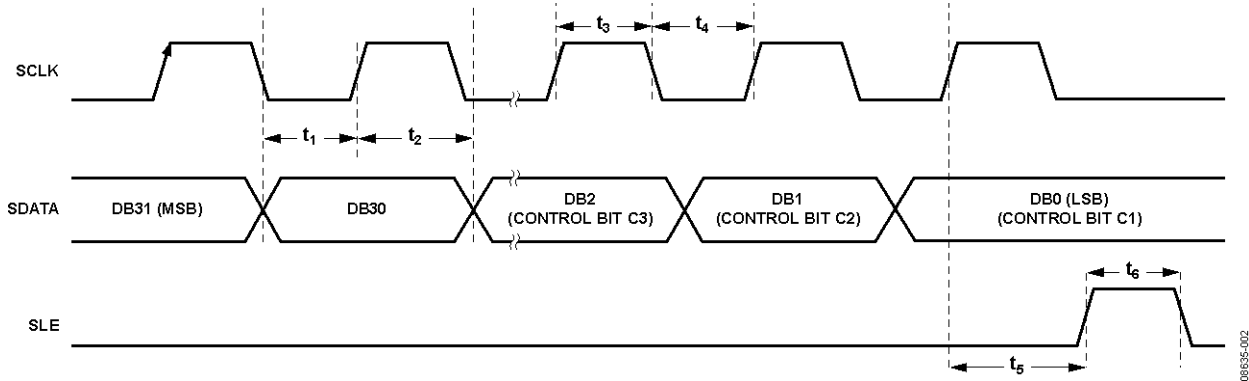

Figure 2. Serial Interface Timing Diagram

08635-002

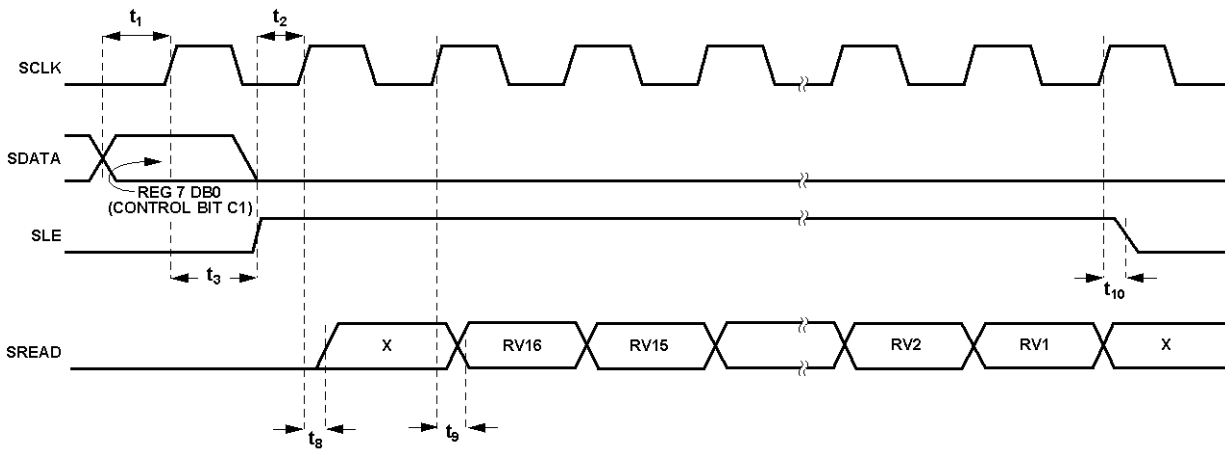

Figure 3. Serial Interface Readback Timing Diagram

08635-003

2FSK/3FSK Timing

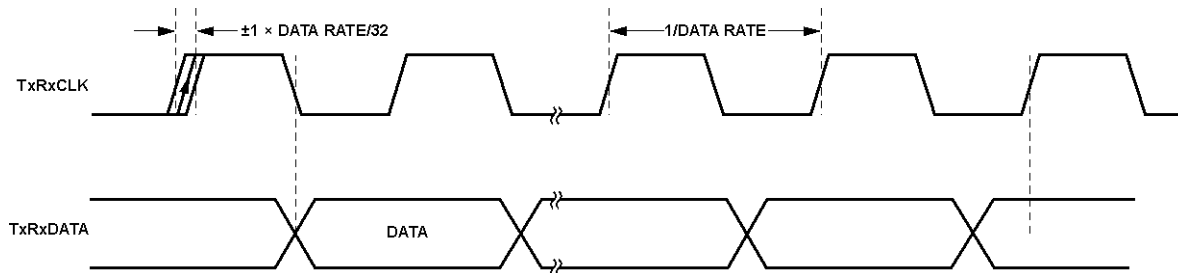

Figure 4. TxRxDATA/TxRxCLK Timing Diagram in Receive Mode

08635-004

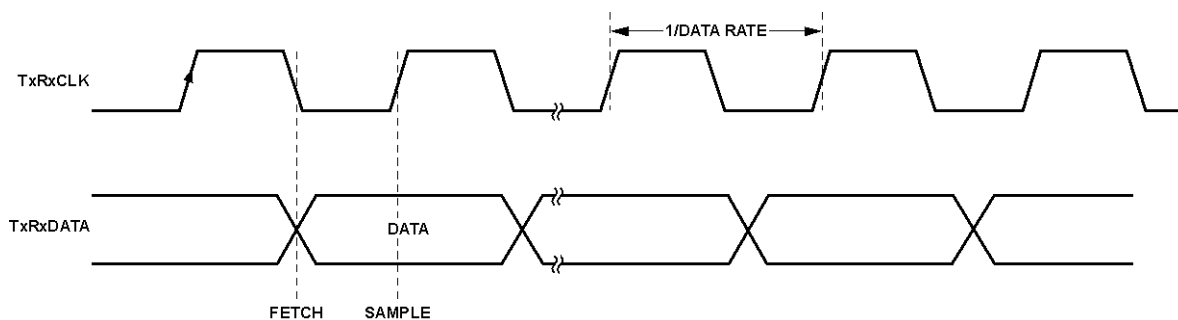

Figure 5. TxRxDATA/TxRxCLK Timing Diagram in Transmit Mode

08635-005

4FSK Timing

In 4FSK receive mode, MSB/LSB synchronization is guaranteed by detection of the SWD pin in the receive bit stream.

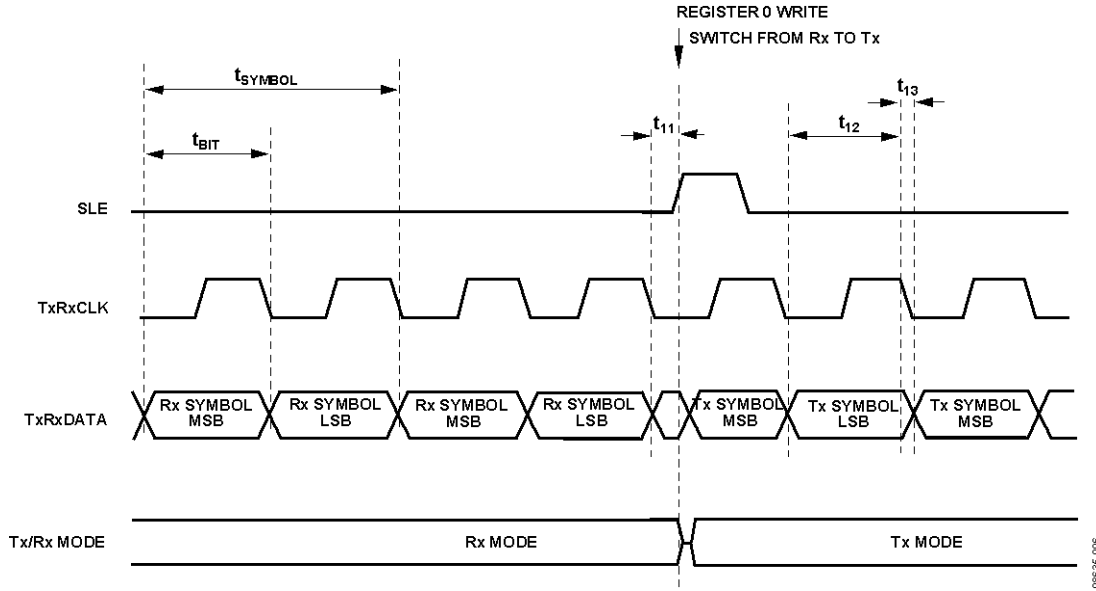

Figure 6. Receive-to-Transmit Timing Diagram in 4FSK Mode

00635-006

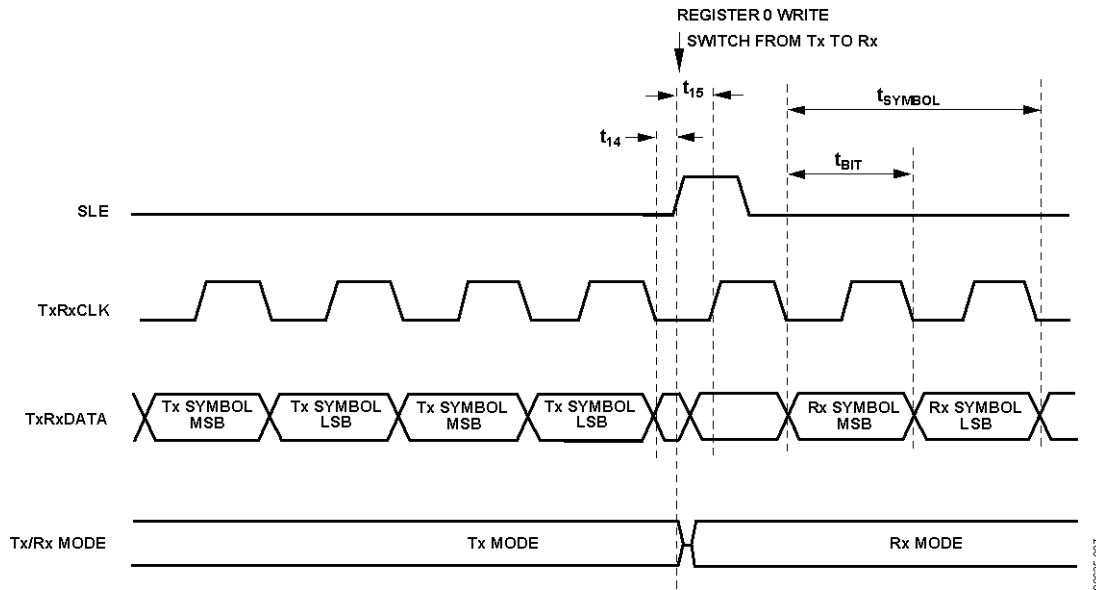

Figure 7. Transmit-to-Receive Timing Diagram in 4FSK Mode

00635-007

UART/SPI Mode

UART mode is enabled by setting Register 0, Bit DB28 to 1. SPI mode is enabled by setting Register 0, Bit DB28 to 1 and setting Register 15, Bits[DB19:DB17] to 0x7. The transmit/receive data clock is available on the CLKOUT pin.

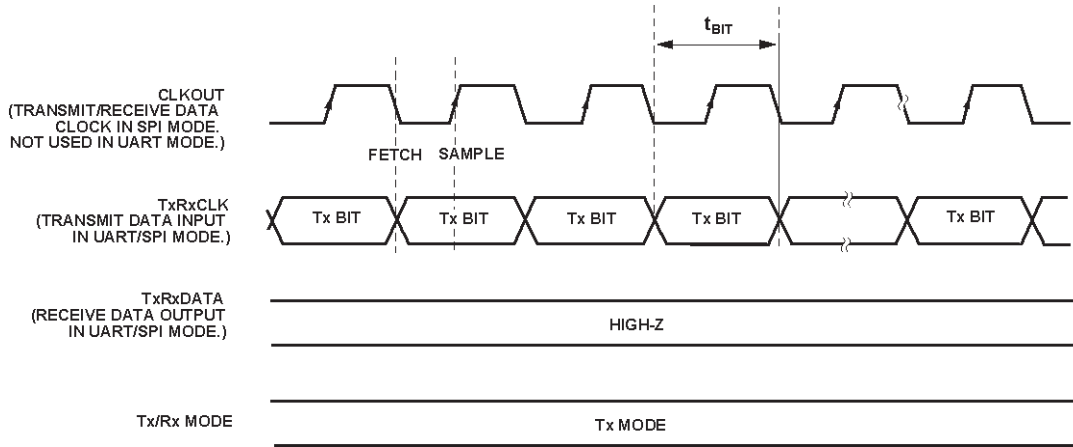

Figure 8. Transmit Timing Diagram in UART/SPI Mode

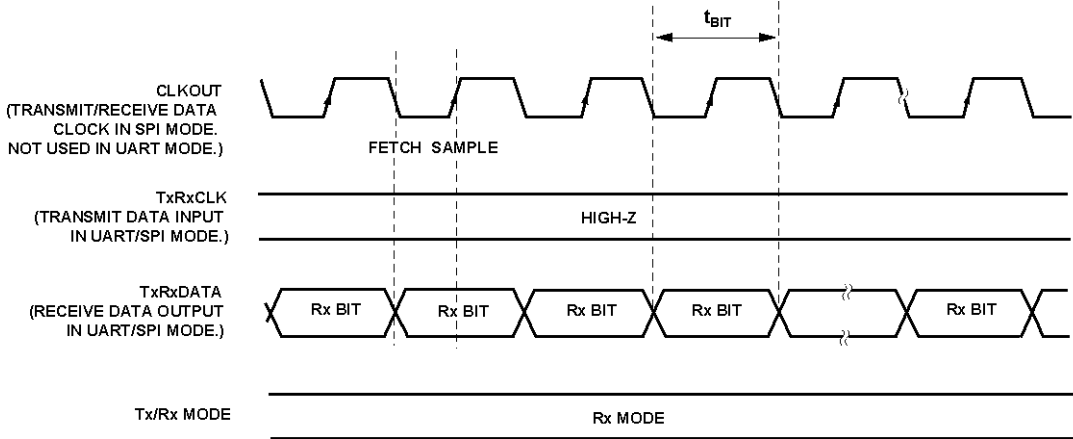

Figure 9. Receive Timing Diagram in UART/SPI Mode

ABSOLUTE MAXIMUM RATINGS

$T_A = 25^\circ\text{C}$, unless otherwise noted.

Table 7.

Parameter	Rating
V_{DD} to GND ¹	-0.3 V to +5 V
Analog I/O Voltage to GND ¹	-0.3 V to $V_{DDx} + 0.3$ V
Digital I/O Voltage to GND ¹	-0.3 V to $V_{DDx} + 0.3$ V
Operating Temperature Range	
Industrial (B Version)	-40°C to +85°C
Storage Temperature Range	-65°C to +125°C
Maximum Junction Temperature	150°C
MLF θ_{JA} Thermal Impedance	26°C/W
Reflow Soldering	
Peak Temperature	260°C
Time at Peak Temperature	40 sec

¹GND = GND1 = GND2 = GND4 = RFGND = 0 V.

Stresses above those listed under Absolute Maximum Ratings may cause permanent damage to the device. This is a stress rating only; functional operation of the device at these or any other conditions above those indicated in the operational section of this specification is not implied. Exposure to absolute maximum rating conditions for extended periods may affect device reliability.

This device is a high performance RF integrated circuit with an ESD rating of <2 kV, and it is ESD sensitive. Take proper precautions for handling and assembly.

ESD CAUTION



ESD (electrostatic discharge) sensitive device. Charged devices and circuit boards can discharge without detection. Although this product features patented or proprietary protection circuitry, damage may occur on devices subjected to high energy ESD. Therefore, proper ESD precautions should be taken to avoid performance degradation or loss of functionality.

PIN CONFIGURATION AND FUNCTION DESCRIPTIONS

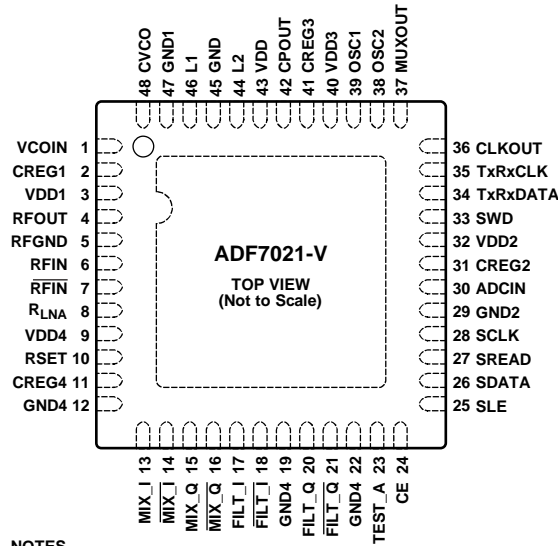

NOTES
 1. THE EXPOSED PADDLE MUST BE CONNECTED TO THE GROUND PLANE.

09895-011

Figure 10. Pin Configuration

Table 8. Pin Function Descriptions

Pin No.	Mnemonic	Description
1	VCOIN	Do not connect.
2	CREG1	Regulator Voltage for PA Block. Place a series 3.9 Ω resistor and a 100 nF capacitor between this pin and ground for regulator stability and noise rejection.
3	VDD1	Voltage Supply for PA Block and VCO Cores. Place decoupling capacitors of 0.1 μF and 100 pF as close as possible to this pin. Tie all VDDx pins together.
4	RFOUT	The modulated signal is available at this pin. Output power levels are from -16 dBm to +13 dBm. Impedance match the output to the desired load using suitable components.
5	RFGND	Ground for Output Stage of Transmitter. Tie all GND pins together.
6	RFIN	LNA Input for Receiver Section. Input matching is required between the antenna and the differential LNA input to ensure maximum power transfer.
7	RFIN	Complementary LNA Input.
8	RLNA	External Bias Resistor for LNA. Optimum resistor is 1.1 kΩ with 5% tolerance.
9	VDD4	Voltage Supply for LNA/Mixer Block. Decouple this pin to ground with a 10 nF capacitor. Tie all VDDx pins together.
10	RSET	External Resistor. Sets charge pump current and some internal bias currents. Use a 3.6 kΩ resistor with 5% tolerance.
11	CREG4	Regulator Voltage for LNA/Mixer Block. Place a 100 nF capacitor between this pin and ground for regulator stability and noise rejection.
12, 19, 22	GND4	Ground for LNA/Mixer Block. Tie all GND pins together.
13 to 16	MIX_I, MIX_I, MIX_Q, MIX_Q	Signal Chain Test Pins. These pins are high impedance under normal conditions; leave the pins unconnected.
17, 18, 20, 21	FILT_I, FILT_I, FILT_Q, FILT_Q	Signal Chain Test Pins. These pins are high impedance under normal conditions; leave the pins unconnected.
23	TEST_A	Signal Chain Test Pin. This pin is high impedance under normal conditions; leave the pins unconnected.
24	CE	Chip Enable. Bringing CE low puts the ADF7021-V into complete power-down. Register values are lost when CE is low, and the part must be reprogrammed after CE is brought high.
25	SLE	Load Enable, CMOS Input. When SLE goes high, the data stored in the shift registers is loaded into one of the 16 latches. A latch is selected using the control bits.
26	SDATA	Serial Data Input. The serial data is loaded MSB first with the four LSBs as the control bits. This pin is a high impedance CMOS input.

Pin No.	Mnemonic	Description
27	SREAD	Serial Data Output. This pin is used to feed readback data from the ADF7021-V to the microcontroller. The SCLK input is used to clock each readback bit (for example, AFC or ADC) from the SREAD pin.
28	SCLK	Serial Clock Input. The serial clock is used to clock in the serial data to the registers. The data is latched into the 32-bit shift register on the SCLK rising edge. This pin is a digital CMOS input.
29	GND2	Ground for Digital Block. Tie all GND pins together.
30	ADCIN	Analog-to-Digital Converter Input. The internal 7-bit ADC can be accessed through this pin. Full scale is 0 V to 1.9 V. Readback is through the SREAD pin.
31	CREG2	Regulator Voltage for Digital Block. Place a 100 nF capacitor between this pin and ground for regulator stability and noise rejection.
32	VDD2	Voltage Supply for Digital Block. Place a decoupling capacitor of 10 nF as close as possible to this pin. Tie all VDDx pins together.
33	SWD	Sync Word Detect. The ADF7021-V asserts this pin when it finds a match for the sync word sequence. This provides an interrupt for an external microcontroller, indicating that valid data is being received.
34	TxRxDATA	Transmit Data Input/Received Data Output. This is a digital pin, and normal CMOS levels apply. In UART/SPI receive mode, this pin provides an output for the received data. In UART/SPI transmit mode, this pin is high impedance.
35	TxRxCLK	Outputs the data clock in both receive and transmit modes. This is a digital pin, and normal CMOS levels apply. The positive clock edge is matched to the center of the received data. In standard transmit mode, this pin outputs an accurate clock to latch the data from the microcontroller into the transmit section at the exact required data rate. In UART/SPI transmit mode, this pin is used to input the transmit data. In UART/SPI receive mode, this pin is high impedance.
36	CLKOUT	Divided-Down Version of the Crystal Reference with Output Driver. The digital clock output can be used to drive several other CMOS inputs, such as a microcontroller clock. The output has a 50:50 mark/space ratio and is inverted with respect to the reference. Place a series 1 k Ω resistor as close as possible to the pin in applications where the CLKOUT feature is used.
37	MUXOUT	Provides the DIGITAL_LOCK_DETECT signal. This signal is used to determine whether the PLL is locked to the correct frequency. It also provides other signals such as REGULATOR_READY, which is an indicator of the status of the serial interface regulator.
38	OSC2	Connect the reference crystal between this pin and OSC1. A TCXO reference can be used by driving this pin with CMOS levels and disabling the internal crystal oscillator.
39	OSC1	Connect the reference crystal between this pin and OSC2. A TCXO reference can be used by driving this pin with ac-coupled 0.8 V p-p levels and by enabling the internal crystal oscillator.
40	VDD3	Voltage Supply for Charge Pump and PLL Dividers. Decouple this pin to ground with a 10 nF capacitor. Tie all VDDx pins together.
41	CREG3	Regulator Voltage for Charge Pump and PLL Dividers. Place a 100 nF capacitor between this pin and ground for regulator stability and noise rejection.
42	CPOUT	Charge Pump Output. This output generates current pulses that are integrated in the loop filter. The integrated current changes the control voltage on the input to the VCO.
43	VDD	Voltage Supply for RF Circuitry. Place a decoupling capacitor of 10 nF as close as possible to this pin. Tie all VDDx pins together.
44	L2	VCO Buffer Input.
45	GND	Ground. Tie all GND pins together.
46	L1	Do not connect.
47	GND1	Ground. Tie all GND pins together.
48	CVCO	Do not connect.
EP	Exposed Paddle	The exposed paddle must be connected to the ground plane.

TYPICAL PERFORMANCE CHARACTERISTICS

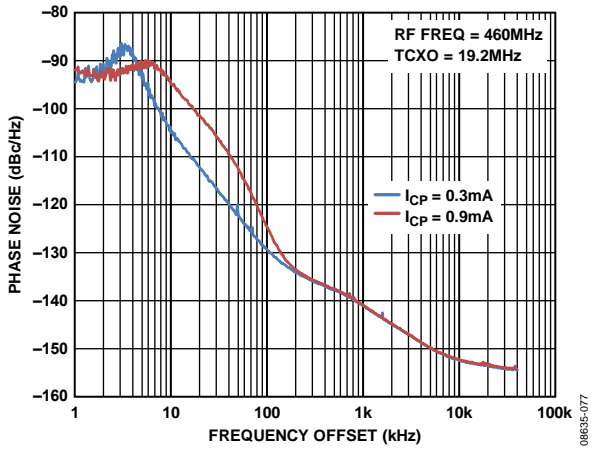

Figure 11. Phase Noise Response at 460 MHz, $V_{DD} = 3 V$

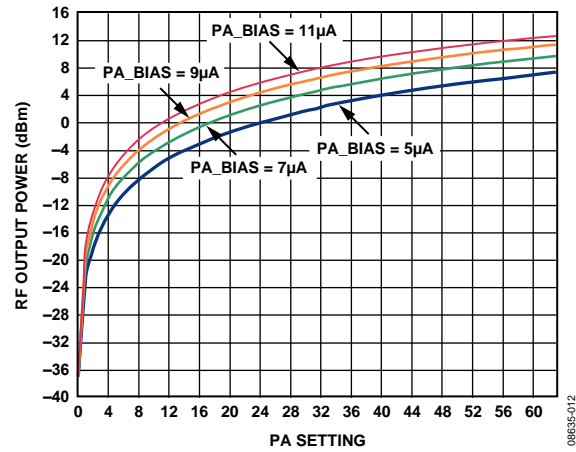

Figure 14. RF Output Power vs. PA Setting

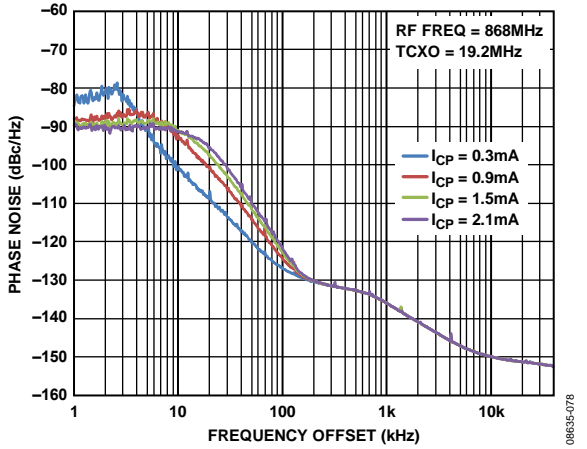

Figure 12. Phase Noise Response at 868 MHz, $V_{DD} = 2.3 V$

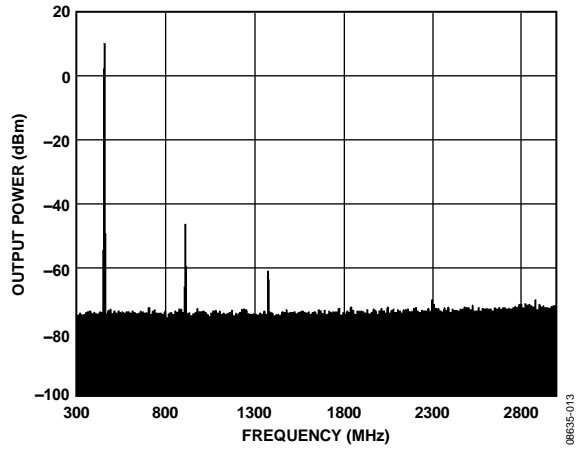

Figure 15. PA Output Harmonic Response with T-Stage LC Filter

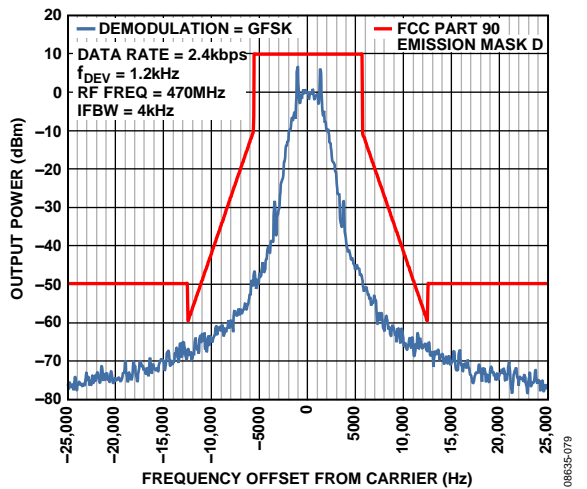

Figure 13. Output Spectrum in FCC Part 90 Emission Mask D and GFSK Modes

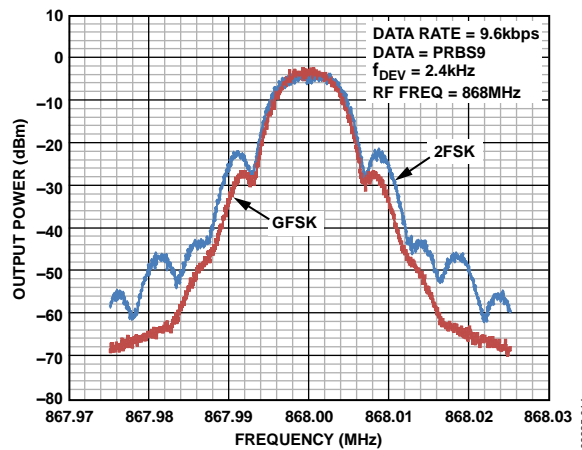

Figure 16. Output Spectrum in 2FSK and GFSK Modes

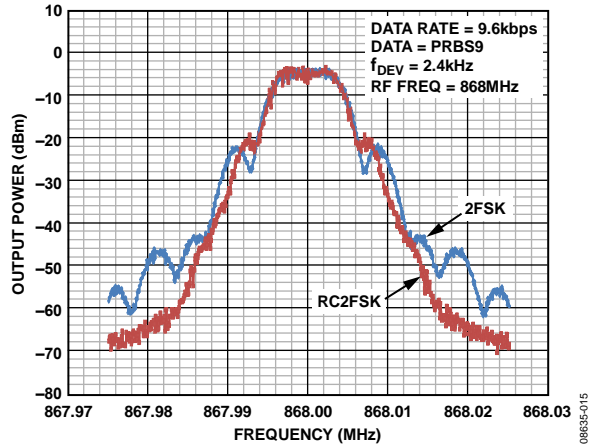

Figure 17. Output Spectrum in 2FSK and Raised Cosine 2FSK Modes

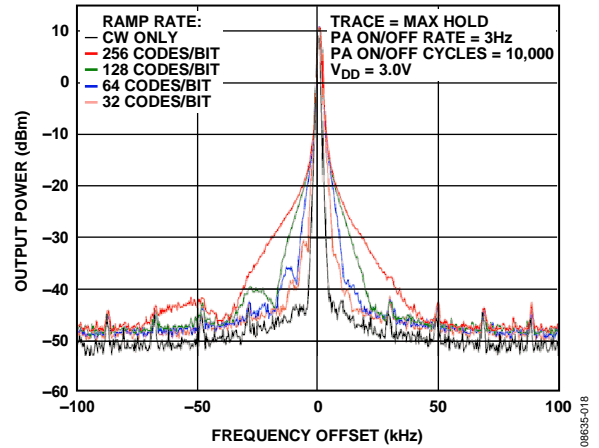

Figure 20. Output Spectrum in Maximum Hold for Various PA Ramp Rate Options

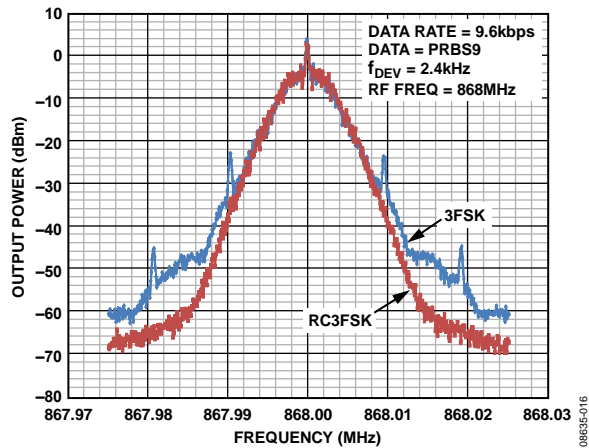

Figure 18. Output Spectrum in 3FSK and Raised Cosine 3FSK Modes

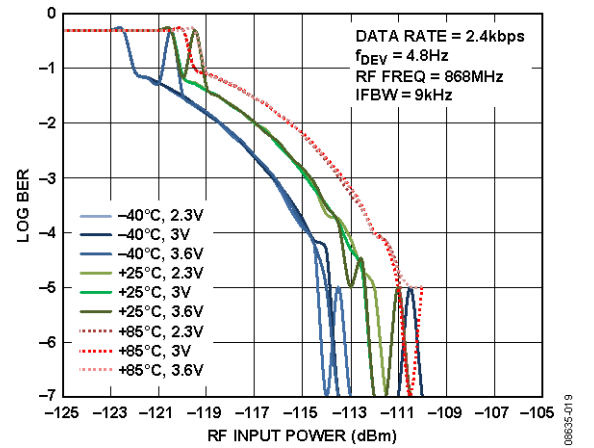

Figure 21. 2FSK Sensitivity vs. V_{DD} and Temperature at 868 MHz

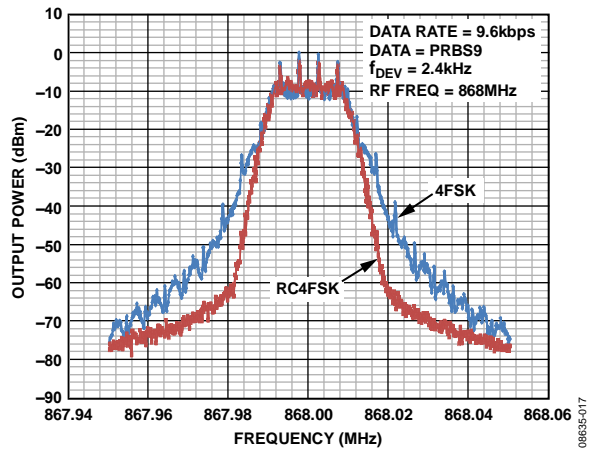

Figure 19. Output Spectrum in 4FSK and Raised Cosine 4FSK Modes

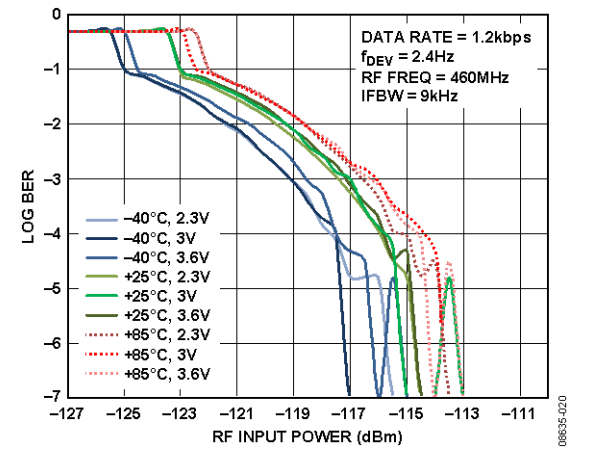

Figure 22. 2FSK Sensitivity vs. V_{DD} and Temperature at 460 MHz

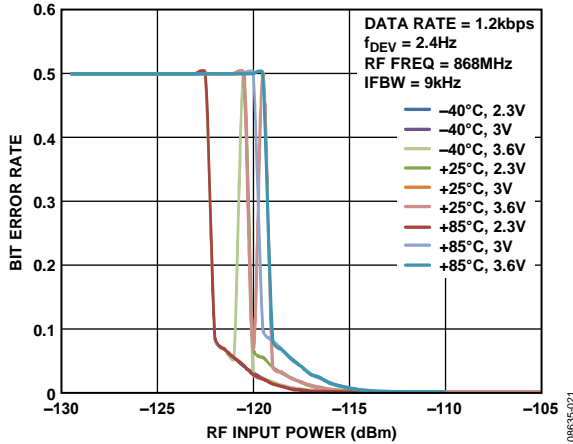

Figure 23. 2FSK Sensitivity vs. V_{DD} and Temperature at 868 MHz

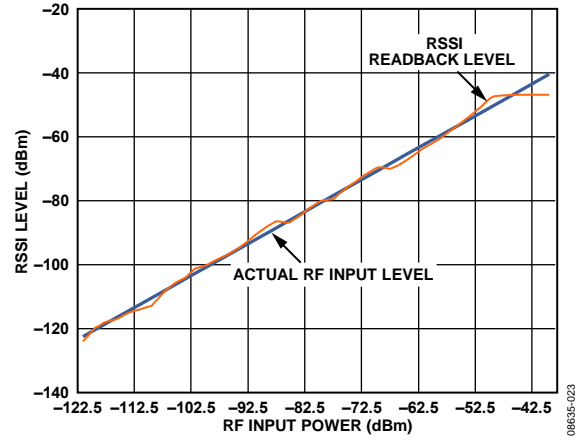

Figure 26. Digital RSSI Readback Linearity

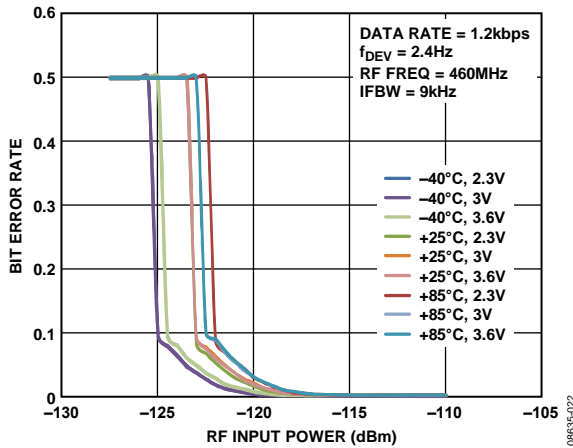

Figure 24. 2FSK Sensitivity vs. V_{DD} and Temperature at 460 MHz

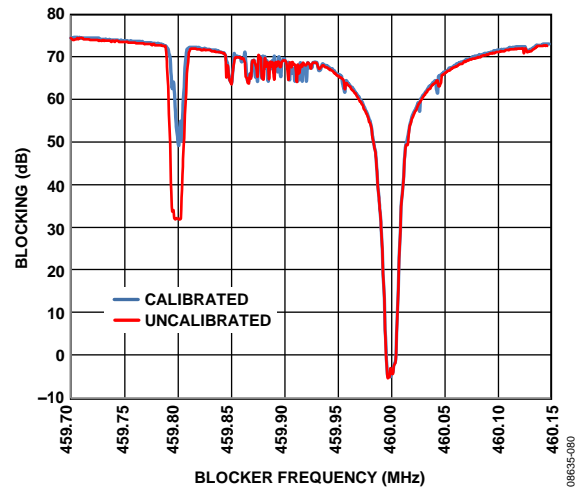

Figure 27. Image Rejection, Uncalibrated vs. Calibrated

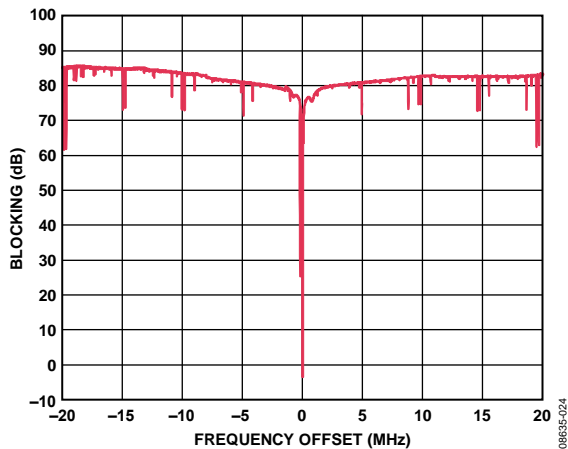

Figure 25. Wideband Interference Rejection (Modulated Carrier Is Swept 20 MHz Either Side of an 868MHz Modulated GFSK 2.4 kHz/4.8 kbps Wanted Signal at the Sensitivity Point (-106.5 dBm); the Power Level of the Blocker Is Adjusted to Give a BER of 10^{-2} ; Interferer Is a GFSK PRBS15 4.8 kHz/2.4 kHz Signal)

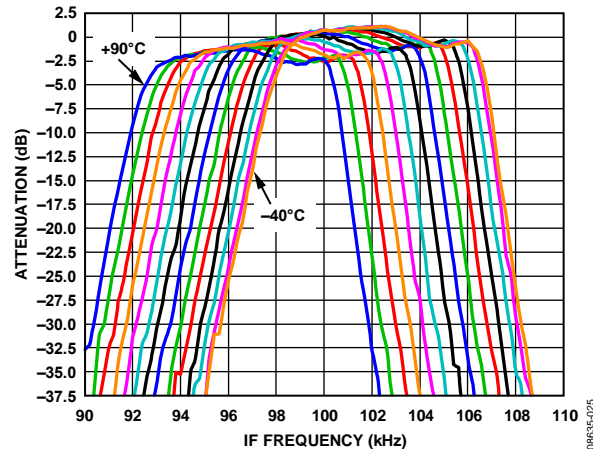

Figure 28. Variation of IF Filter Response with Temperature (IF_FILTER_BW = 9 kHz, Temperature Range Is -40°C to +90°C in 10° Steps)

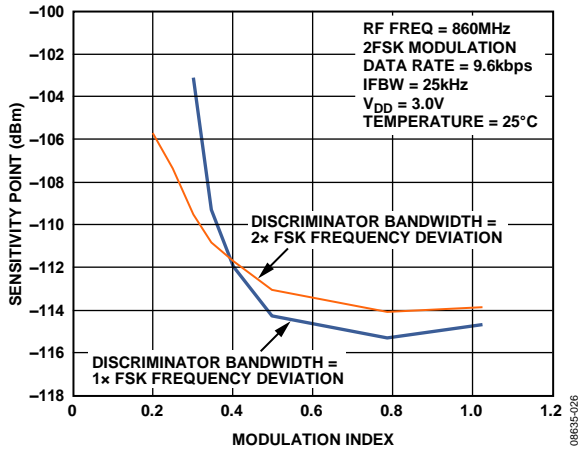

Figure 29. 2FSK Sensitivity vs. Modulation Index and Correlator Discriminator Bandwidth

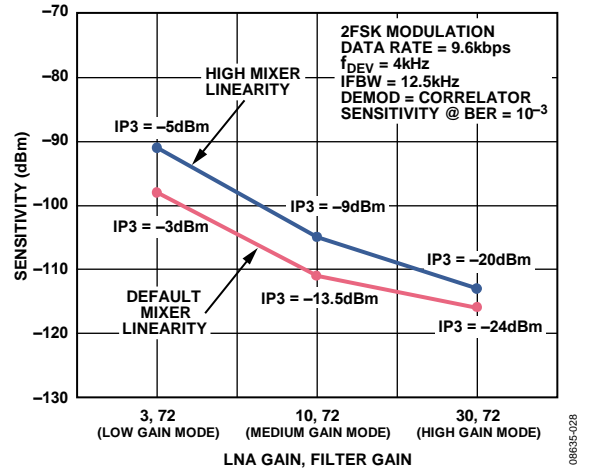

Figure 31. 2FSK Receiver Sensitivity vs. LNA Gain/IF Filter Gain and Mixer Linearity Settings (Input IP3 at Each Setting Also Shown)

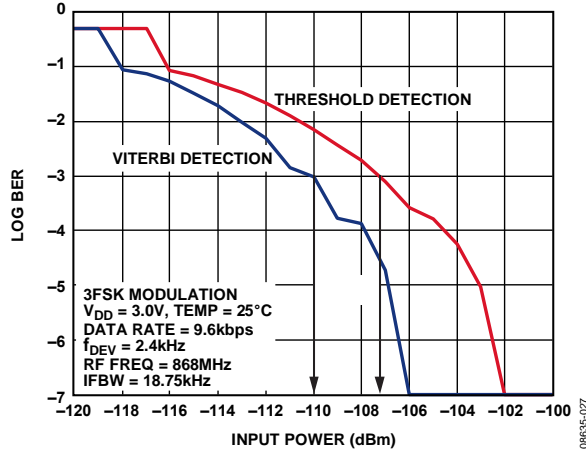

Figure 30. 3FSK Receiver Sensitivity Using Viterbi Detection and Threshold Detection

FREQUENCY SYNTHESIZER

REFERENCE INPUT

The on-board crystal oscillator circuitry (see Figure 32) can use a quartz crystal as the PLL reference. A quartz crystal with a frequency tolerance of ≤ 10 ppm for narrow-band applications is recommended. It is possible to use a quartz crystal with > 10 ppm tolerance, but compensation for the frequency error of the crystal is necessary to comply with the absolute frequency error specifications of narrow-band regulations (for example, ARIB STD-T67 and ETSI EN 300 220).

The oscillator circuit is enabled by setting Bit DB12 in Register 1 high. It is enabled by default on power-up and is disabled by bringing CE low. Errors in the crystal can be corrected using the automatic frequency control (AFC) feature or by adjusting the fractional-N value (see the N Counter section).

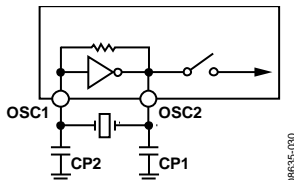

Figure 32. Crystal Oscillator Circuit on the ADF7021-V

Two parallel resonant capacitors are required for oscillation at the correct frequency. Their values are dependent on the crystal specification. Select the resonant capacitors to ensure that the series value of capacitance added to the PCB track capacitance adds up to the specified load capacitance of the crystal, usually 12 pF to 20 pF. Track capacitance values vary from 2 pF to 5 pF, depending on board layout. When possible, choose capacitors that have a very low temperature coefficient to ensure stable frequency operation over all conditions.

Using a TCXO Reference

A single-ended reference (TCXO, VCXO, or OCXO) can also be used with the ADF7021-V. This is recommended for applications that have absolute frequency accuracy requirements of < 10 ppm, such as applications requiring compliance with ARIB STD-T67 or ETSI EN 300 220. The following are two options for interfacing the ADF7021-V to an external reference oscillator.

- An oscillator with CMOS output levels can be applied to OSC2. Disable the internal oscillator circuit by setting Bit DB12 in Register 1 low.
- An oscillator with 0.8 V p-p levels can be ac-coupled through a 22 pF capacitor into OSC1. Enable the internal oscillator circuit by setting Bit DB12 in Register 1 high.

Programmable Crystal Bias Current

Bias current in the oscillator circuit can be configured from 20 μ A to 35 μ A by writing to the XTAL_BIAS bits (Register 1, Bits[DB14:DB13]). Increasing the bias current allows the crystal oscillator to power up faster.

CLKOUT Divider and Buffer

The CLKOUT circuit takes the reference clock signal from the oscillator section, shown in Figure 32, and supplies a divided-down, 50:50 mark/space signal to the CLKOUT pin. The CLKOUT signal is inverted with respect to the reference clock. An even divide from 2 to 30 is available; this divide number is set in Register 1, Bits[DB10:DB7]. On power-up, the CLKOUT defaults to divide-by-8.

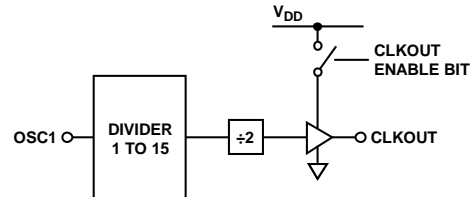

Figure 33. CLKOUT Stage

To disable CLKOUT, set the divide number to 0. The output buffer can drive a load of up to 20 pF with a 10% rise time at 4.8 MHz. Faster edges can result in some spurious feedthrough to the output. A series resistor (1 k Ω) can be used to slow the clock edges to reduce these spurs at the CLKOUT frequency.

R Counter

The 3-bit R counter divides the reference input frequency by an integer from 1 to 7. The divided-down signal is presented as the reference clock to the phase frequency detector (PFD). The divide ratio is set in Register 1, Bits[DB6:DB4]. Maximizing the PFD frequency reduces the N value. This reduces the noise multiplied at a rate of $20 \log(N)$ to the output and reduces occurrences of spurious components.

Register 1 defaults to R = 1 on power-up.

$$PFD \text{ (Hz)} = XTAL/R$$

Loop Filter

The loop filter integrates the current pulses from the charge pump to form a voltage that tunes the output of the VCO to the desired frequency. It also attenuates spurious levels generated by the PLL. A typical loop filter design is shown in Figure 34.

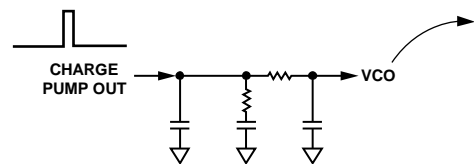

Figure 34. Typical Loop Filter Configuration

Design the loop so that the loop bandwidth (LBW) is approximately 6 kHz. This provides a good compromise between in-band phase noise and out-of-band spurious rejection. Widening the LBW excessively reduces the time spent jumping between frequencies, but it can cause insufficient spurious attenuation. Use the loop filter design on the EVAL-ADF7021-VDBxZ for optimum performance.

The free design tool ADIsimSRD™ Design Studio can also be used to design loop filters for the ADF7021-V. See the ADIsimSRD Design Studio website (www.analog.com/adisimsrd) for details).

N Counter

The feedback divider in the ADF7021-V PLL consists of an 8-bit integer counter (set using Register 0, Bits[DB26:DB19]) and a 15-bit, Σ-Δ fractional-N divider (set using Register 0, Bits[DB18:DB4]). The integer counter is the standard pulse-swallow type that is common in PLLs. It sets the minimum integer divide value to 23. The fractional divide value provides very fine resolution at the output, where the output frequency of the PLL is calculated as

$$f_{OUT} = \frac{XTAL}{R} \times \left(INTEGER_N + \frac{FRACTIONAL_N}{2^{15}} \right)$$

When RF_DIVIDE_BY_2 is enabled (see the Voltage Controlled Oscillator (VCO) section), this formula becomes

$$f_{OUT} = \frac{XTAL}{R} \times 0.5 \times \left(INTEGER_N + \frac{FRACTIONAL_N}{2^{15}} \right)$$

The combination of INTEGER_N (maximum = 255) and FRACTIONAL_N (maximum = 32,768/32,768) gives a maximum N divider of 255 + 1. Therefore, the minimum usable PFD is

$$PFD_{MIN} \text{ (Hz)} = \frac{\text{MaximumRequiredOutput Frequency}}{(255+1)}$$

For example, when operating in the European 868 MHz to 870 MHz band, PFD_{MIN} = 3.4 MHz.

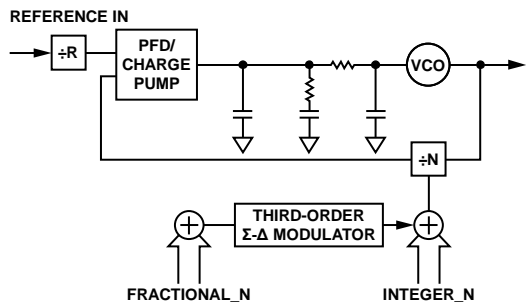

Figure 35. Fractional-N PLL

Voltage Regulators

The ADF7021-V contains four regulators to supply stable voltages to the part. The nominal regulator voltage is 2.3 V. Regulator 1 requires a 3.9 Ω resistor and a 100 nF capacitor in series between CREG1 and ground, whereas the other regulators require a 100 nF capacitor connected between CREGx and ground. When CE is high, the regulators and other associated circuitry are powered on, drawing a total supply current of 2 mA. Bringing the CE pin low disables the regulators, reduces the supply current to less than 1 μA, and erases all values held in the registers.

The serial interface operates from a regulator supply. Therefore, to write to the part, CE must be high and the regulator voltage must be stabilized. Regulator status (CREG4) can be monitored using the REGULATOR_READY signal from the MUXOUT pin.

MUXOUT

The MUXOUT pin allows access to various digital points in the ADF7021-V. The state of MUXOUT is controlled in Register 0, Bits[DB31:DB29].

REGULATOR_READY

REGULATOR_READY is the default setting on MUXOUT after the transceiver is powered up. The power-up time of the regulator is typically 50 μs. Because the serial interface is powered from the regulator, the regulator must be at its nominal voltage before the ADF7021-V can be programmed. The regulator status can be monitored at MUXOUT. When the regulator ready signal on MUXOUT is high, programming of the ADF7021-V can begin.

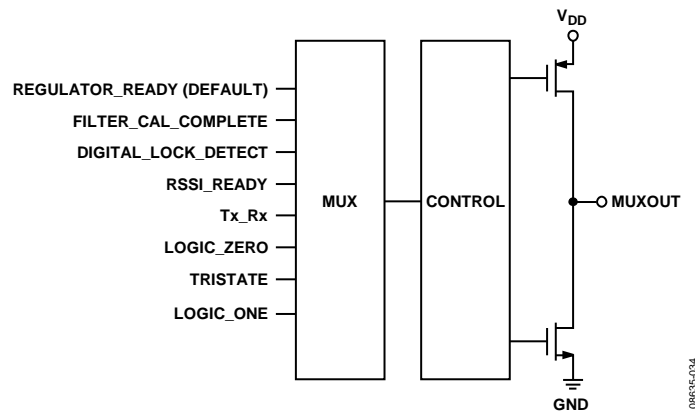

Figure 36. MUXOUT Circuit

FILTER_CAL_COMPLETE

MUXOUT can be set to FILTER_CAL_COMPLETE. This signal goes low for the duration of both a coarse IF filter calibration and a fine IF filter calibration. It can be used as an interrupt to a microcontroller to signal the end of the IF filter calibration.

DIGITAL_LOCK_DETECT

DIGITAL_LOCK_DETECT indicates when the PLL has locked. The lock detect circuit is located at the PFD. When the phase error on five consecutive cycles is less than 15 ns, lock detect is set high. Lock detect remains high until a 25 ns phase error is detected at the PFD.

RSSI_READY

MUXOUT can be set to RSSI_READY. This indicates that the internal analog RSSI has settled and that a digital RSSI readback can be performed.

Tx_Rx

Tx_Rx signifies whether the ADF7021-V is in transmit or receive mode. When in transmit mode, this signal is low. When in receive mode, this signal is high. It can be used to control an external Tx/Rx switch.

VOLTAGE CONTROLLED OSCILLATOR (VCO)

To minimize feedthrough and spurious emissions, the external VCO must be chosen to operate at a minimum of twice the required RF frequency. The VCO frequency is divided by 2 inside the synthesizer loop, providing the required frequency for the transmitter and for the local oscillator (LO) of the receiver. For improved phase noise performance, an additional divide-by-2 can be enabled by setting the RF_DIVIDE_BY_2 bit (Bit DB18) in Register 1.

As an example, for 80 MHz operation, a 160 MHz external VCO could be used with the RF_DIVIDE_BY_2 bit disabled, or a 320 MHz VCO could be used with the RF_DIVIDE_BY_2 bit enabled to support operation in the 80 MHz band. Assuming that both VCOs have similar phase noise performance, the 320 MHz design using the additional divide-by-2 results in improved transmit ACP, as well as improved ACR, blocking, and image rejection in the receiver.

The maximum VCO frequency of operation supported on the ADF7021-V is 1920 MHz, which results in a maximum RF channel frequency of 960 MHz using a $2\times$ VCO or 480 MHz using a $4\times$ VCO.

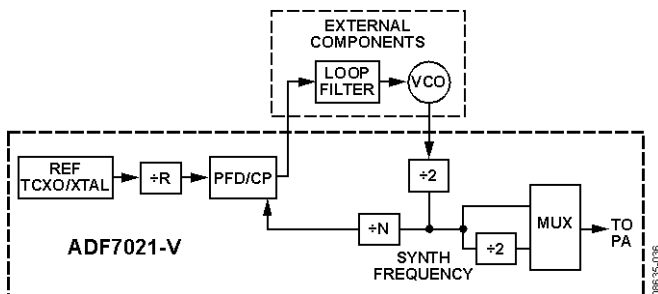

Figure 37. Voltage Controlled Oscillator (VCO)

The VCO tuning voltage can be checked for a particular RF output frequency by measuring the voltage on the CPOUT pin when the part is fully powered up in transmit or receive mode. The VCO tuning range of the external VCO must be 0.2 V to 2 V.

The input impedance of the L2 pin is programmable and can be selected to have a high impedance value or $50\ \Omega$ impedance, depending on the VCO selected. The impedance of this pin can be set using the BUFFER_IMPEDANCE bit (Bit DB17) in Register 1.

CHOOSING A VCO FOR BEST SYSTEM PERFORMANCE

The interaction between the RF VCO frequency and the reference frequency can lead to fractional spur creation. When the synthesizer is in fractional mode (that is, the RF VCO and reference frequencies are not integer related), spurs can appear on the VCO output spectrum at an offset frequency that corresponds to the difference frequency between an integer multiple of the reference and the VCO frequency.

These spurs are attenuated by the loop filter. They are more noticeable on channels close to integer multiples of the reference where the difference frequency may be inside the loop bandwidth (thus, the name integer boundary spurs). The occurrence of these spurs is rare because the integer frequencies are around multiples of the reference, which is typically >10 MHz. To avoid having very small or very large values in the fractional register, choose a suitable reference frequency.

In addition to spurious considerations, the selection of a high performance VCO with very low phase noise is essential to minimize the ACP performance of the transmitter and to maximize the ACR and blocking resilience of the receiver.

TRANSMITTER

RF OUTPUT STAGE

The power amplifier (PA) of the **ADF7021-V** is based on a single-ended, controlled current, open-drain amplifier that has been designed to deliver up to 13 dBm into a 50 Ω load at a maximum frequency of 960 MHz.

The PA output current and, consequently, the output power are programmable over a wide range. The PA configuration is shown in Figure 38. The output power is set using Register 2, Bits[DB18:DB13].

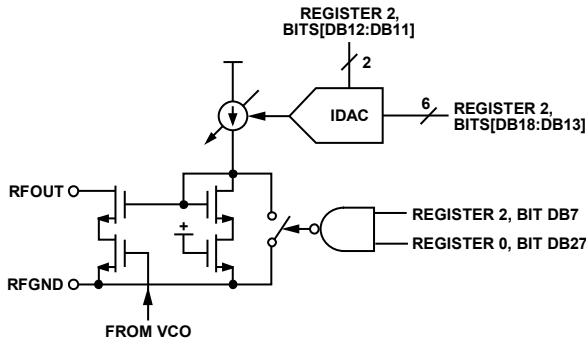

Figure 38. PA Configuration

The PA is equipped with overvoltage protection, which makes it robust in severe mismatch conditions. Depending on the application, users can design a matching network for the PA to exhibit optimum efficiency at the desired radiated output power level for a wide range of antennas, such as loop or monopole antennas. See the LNA/PA Matching section for more information.

PA Ramping

When the PA is switched on or off quickly, its changing input impedance momentarily disturbs the VCO output frequency. This process is called VCO pulling, and it manifests as spectral splatter or spurs in the output spectrum around the desired carrier frequency. Some radio emissions regulations place limits on these PA transient-induced spurs (for example, the ETSI EN 300 220 regulations). By gradually ramping the PA on and off, PA transient spurs are minimized.

The **ADF7021-V** has built-in PA ramping configurability. As Figure 39 illustrates, there are eight ramp rate settings, defined as a certain number of PA setting codes per one data bit period. The PA steps through each of its 64 code levels but at different speeds for each setting. The ramp rate is set by configuring Bits[DB10:DB8] in Register 2.

If the PA is enabled/disabled by the PA_ENABLE bit (Register 2, Bit DB7), it ramps up and down. If it is enabled/disabled by the Tx/Rx bit (Register 0, Bit DB27), it ramps up and turns hard off.

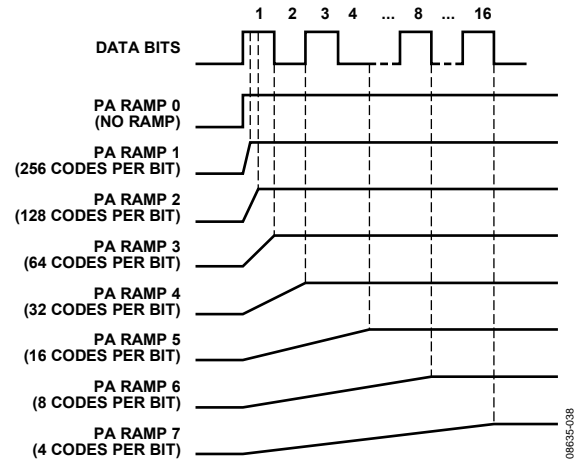

Figure 39. PA Ramping Settings

PA Bias Currents

The PA_BIAS bits (Register 2, Bits[DB12:DB11]) facilitate an adjustment of the PA bias current to further extend the output power control range, if necessary. If this feature is not required, the default value of 9 μA is recommended. If output power greater than 10 dBm is required, a PA bias setting of 11 μA is recommended. The output stage is powered down by resetting Register 2, Bit DB7 to 0.

MODULATION SCHEMES

The **ADF7021-V** supports 2FSK, 3FSK, and 4FSK modulation. The implementation of these modulation schemes is shown in Figure 40.

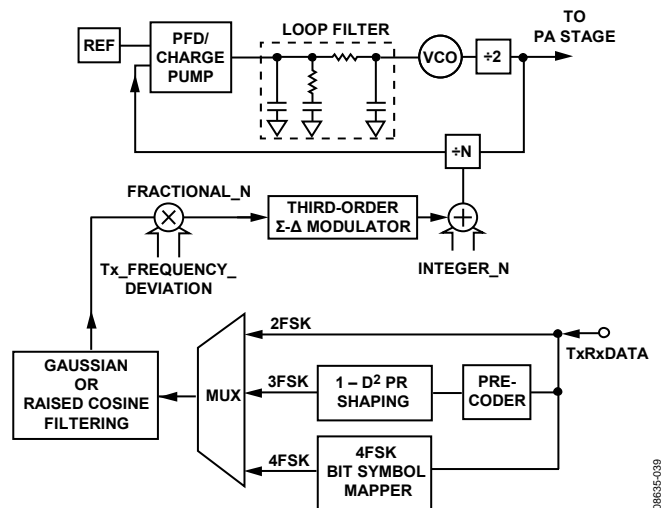

Figure 40. Transmit Modulation Implementation

Setting the Transmit Data Rate

In all modulation modes except for oversampled 2FSK mode, an accurate clock is provided on the TxRxCLK pin to latch the data from the microcontroller into the transmit section at the required data rate. The exact frequency of this clock is defined by

$$DATACLK = \frac{XTAL}{DEMOC_CLK_DIVIDE \times CDR_CLK_DIVIDE \times 32}$$

where:

XTAL is the crystal or TCXO frequency.

DEMOC_CLK_DIVIDE is the divider that sets the demodulator clock rate (Register 3, Bits[DB9:DB6]).

CDR_CLK_DIVIDE is the divider that sets the CDR clock rate (Register 3, Bits[DB17:DB10]).

See the Register 3—Transmit/Receive Clock Register section for more programming information.

Setting the FSK Transmit Deviation Frequency

In all modulation modes, the deviation from the center frequency is set using the Tx_FREQUENCY_DEVIATION bits (Register 2, Bits[DB27:DB19]).

The deviation from the center frequency in Hz is as follows:

For direct RF output,

$$f_{DEV} \text{ (Hz)} = \frac{PFD \times Tx_FREQUENCY_DEVIATION}{2^{16}}$$

With RF_DIVIDE_BY_2 (Register 1, Bit DB18) enabled,

$$f_{DEV} \text{ (Hz)} = 0.5 \times \frac{PFD \times Tx_FREQUENCY_DEVIATION}{2^{16}}$$

where Tx_FREQUENCY_DEVIATION is a number from 1 to 511 (Register 2, Bits[DB27:DB19]).

In 4FSK modulation, the four symbols (00, 01, 11, 10) are transmitted as $\pm 3 \times f_{DEV}$ and $\pm 1 \times f_{DEV}$.

Binary Frequency Shift Keying (2FSK)

Binary frequency shift keying is implemented by setting the N value for the center frequency and then toggling it with the TxRxDATA line. The deviation from the center frequency is set using the Tx_FREQUENCY_DEVIATION bits (Register 2, Bits[DB27:DB19]).

2FSK is selected by setting the MODULATION_SCHEME bits (Register 2, Bits[DB6:DB4]) to 000.

Minimum shift keying (MSK) or Gaussian minimum shift keying (GMSK) is supported by selecting 2FSK modulation and using a modulation index of 0.5. A modulation index of 0.5 is set by configuring Register 2, Bits[DB27:DB19] for an $f_{DEV} = 0.25 \times$ transmit data rate.

Three-Level Frequency Shift Keying (3FSK)

In three-level FSK modulation—3FSK, also known as modified duobinary FSK and as partial response maximum likelihood Class 4 (PRML4) signaling—the binary data (Logic 0 and Logic 1) is mapped onto three distinct frequencies: the carrier frequency (f_C), the carrier frequency minus a deviation frequency ($f_C - f_{DEV}$), and the carrier frequency plus the deviation frequency ($f_C + f_{DEV}$).

A Logic 0 is mapped to the carrier frequency, whereas a Logic 1 is mapped onto either the $f_C - f_{DEV}$ frequency or the $f_C + f_{DEV}$ frequency.

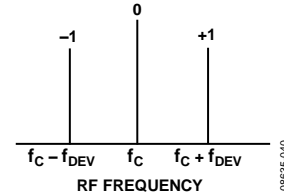

Figure 41. 3FSK Symbol-to-Frequency Mapping

Compared with 2FSK, this bit-to-frequency mapping results in a reduced transmission bandwidth because some energy is removed from the RF sidebands and transferred to the carrier frequency. At low modulation index, 3FSK improves the transmit spectral efficiency by up to 25% when compared with 2FSK.

The bit-to-symbol mapping for 3FSK is implemented using a linear convolutional encoder that also permits Viterbi detection to be used in the receiver. A block diagram of the transmit hardware used to realize this system is shown in Figure 42. The convolutional encoder polynomial used to implement the transmit spectral shaping is

$$P(D) = 1 - D^2$$

where:

P is the convolutional encoder polynomial.

D is the unit delay operator.

A digital precoder with transfer function $1/P(D)$ implements an inverse modulo-2 operation of the $1 - D^2$ shaping filter in the transmitter.

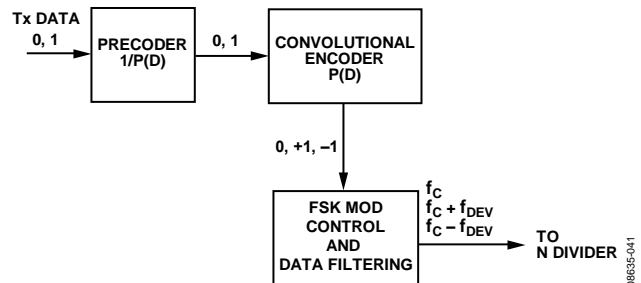

Figure 42. 3FSK Encoding

The signal mapping of the input binary transmit data to the three-level convolutional output is shown in Table 9. The convolutional encoder restricts the maximum number of sequential +1s or -1s to two and delivers an equal number of +1s and -1s to the FSK modulator, thus ensuring equal spectral energy in both RF sidebands.

Table 9. Three-Level Signal Mapping of the Convolutional Encoder

TxDATA	1	0	1	1	0	0	1	0	0	1
Precoder Output	1	0	0	1	0	1	1	1	1	0
Encoder Output	+1	0	-1	+1	0	0	+1	0	0	-1

Another property of this encoding scheme is that the transmitted symbol sequence is dc-free, which facilitates symbol detection and frequency measurement in the receiver. In addition, no code rate loss is associated with this three-level convolutional encoder; that is, the transmitted symbol rate is equal to the data rate presented at the transmit data input.

3FSK is selected by setting the MODULATION_SCHEME bits (Register 2, Bits[DB6:DB4]) to 010. It can also be used with raised cosine filtering to further increase the spectral efficiency of the transmit signal.

Four-Level Frequency Shift Keying (4FSK)

In 4FSK modulation, two bits per symbol spectral efficiency is realized by mapping consecutive input bit-pairs in the Tx data bit stream to one of four possible symbols (-3, -1, +1, +3). Thus, the transmitted symbol rate is half the input bit rate. These symbols are mapped to equally spaced discrete frequencies centered on the RF carrier at

$$-3f_{DEV}, -1f_{DEV}, +1f_{DEV}, \text{ and } +3f_{DEV}$$

where f_{DEV} is programmed using the Tx_FREQUENCY_DEVIATION bits (Bits[DB27:DB19] in Register 2) and is also equal to half the frequency spacing between adjacent symbols.

By minimizing the separation between symbol frequencies, 4FSK can have high spectral efficiency. The bit-to-symbol mapping for 4FSK is gray coded and is shown in Figure 43.

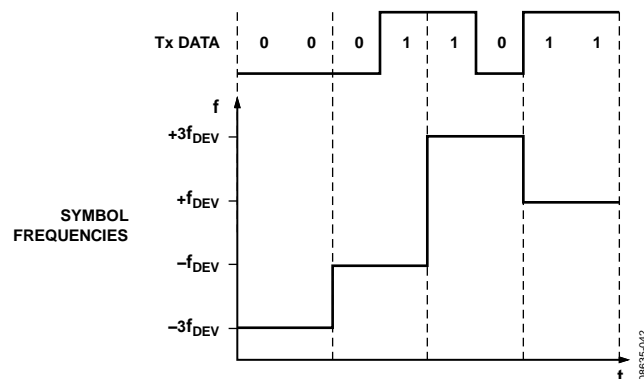

Figure 43. 4FSK Bit-to-Symbol Mapping

The inner deviation frequencies ($+f_{DEV}$ and $-f_{DEV}$) are set using the Tx_FREQUENCY_DEVIATION bits (Bits[DB27:DB19] in Register 2). The outer deviation frequencies are automatically set to three times the inner deviation frequency.

The transmit clock from Pin TxRxCLK is available after writing to Register 3 in the power-up sequence for receive mode. Clock the MSB of the first symbol into the ADF7021-V on the first transmit clock pulse from the ADF7021-V after writing to Register 3. See Figure 6 and Figure 7 for more timing information; see Figure 54 and Figure 55 for the power-up sequences.

Oversampled 2FSK

In oversampled 2FSK, there is no data clock from the TxRxCLK pin. Instead, the transmit data at the TxRxDATA pin is sampled at 32 times the programmed rate.

Oversampled 2FSK is the only modulation mode that can be used with the UART mode interface for data transmission (see the Interfacing to a Microcontroller/DSP section for more information).

SPECTRAL SHAPING

Gaussian or raised cosine filtering can be used to improve transmit spectral efficiency. The ADF7021-V supports Gaussian filtering (bandwidth time [BT] = 0.5) on 2FSK modulation. Raised cosine filtering can be used with 2FSK, 3FSK, or 4FSK modulation. The roll-off factor (alpha) of the raised cosine filter has programmable options of 0.5 and 0.7. Both the Gaussian and raised cosine filters are implemented using linear phase digital filter architectures that deliver precise control over the BT and alpha filter parameters, and guarantee a transmit spectrum that is very stable over temperature and supply variation.

Gaussian Frequency Shift Keying (GFSK)

Gaussian frequency shift keying reduces the bandwidth occupied by the transmitted spectrum by digitally prefiltering the transmit data. The BT product of the Gaussian filter used is 0.5.

Gaussian filtering can be used only with 2FSK modulation. GFSK is selected by setting Register 2, Bits[DB6:DB4] to 001.

Raised Cosine Filtering

Raised cosine filtering provides digital prefiltering of the transmit data by using a raised cosine filter with a roll-off factor (alpha) of either 0.5 or 0.7. The alpha is set to 0.5 by default, but the raised cosine filter bandwidth can be increased to provide less aggressive data filtering by using an alpha of 0.7 (set Register 2, Bit DB30 to Logic 1). Raised cosine filtering can be used with 2FSK, 3FSK, and 4FSK modulation.

Raised cosine filtering is enabled by setting Register 2, Bits[DB6:DB4] as shown in Table 10.

MODULATION AND FILTERING OPTIONS

The various modulation and data filtering options for the ADF7021-V are described in Table 10.

Table 10. Modulation and Filtering Options

Modulation	Data Filtering	Register 2, Bits[DB6:DB4]
Binary FSK		
2FSK	None	000
MSK ¹	None	000
OQPSK with Half Sine Baseband Shaping ²	None	000
GFSK	Gaussian	001
GMSK ³	Gaussian	001
RC2FSK	Raised cosine	101
Oversampled 2FSK	None	100
Three-Level FSK		
3FSK	None	010
RC3FSK	Raised cosine	110
Four-Level FSK		
4FSK	None	011
RC4FSK	Raised cosine	111

¹ MSK is 2FSK modulation with a modulation index = 0.5.

² Offset quadrature phase shift keying (OQPSK) with half sine baseband shaping is spectrally equivalent to MSK.

³ GMSK is GFSK with a modulation index = 0.5.

TRANSMIT LATENCY

Transmit latency is the delay time from the sampling of a bit/symbol by the TxRxCLK signal to when that bit/symbol appears at the RF output. The latency without any data filtering is 1 bit. The addition of data filtering adds a further latency as indicated in Table 11.

It is important that the ADF7021-V be left in transmit mode after the last data bit is sampled by the data clock to account for this latency. Maintain the ADF7021-V in transmit mode for a time equal to the number of latency bit periods for the applied modulation scheme. This ensures that all of the data sampled by the TxRxCLK signal appears at RF.

The figures for latency in Table 11 assume that the positive TxRxCLK edge is used to sample data (default). If the TxRxCLK is inverted by setting Register 2, Bits[DB29:DB28], an additional 0.5 bit latency can be added to all values in Table 11.

Table 11. Bit/Symbol Latency in Transmit Mode for Various Modulation Schemes

Modulation	Latency
2FSK	1 bit
GFSK	4 bits
RC2FSK, alpha = 0.5	5 bits
RC2FSK, alpha = 0.7	4 bits
3FSK	1 bit
RC3FSK, alpha = 0.5	5 bits
RC3FSK, alpha = 0.7	4 bits
4FSK	1 symbol
RC4FSK, alpha = 0.5	5 symbols
RC4FSK, alpha = 0.7	4 symbols

TEST PATTERN GENERATOR

The ADF7021-V has a number of built-in test pattern generators that can be used to facilitate radio link setup or RF measurement.

A full list of the supported test patterns is shown in Table 12.

The data rate for these test patterns is the programmed data rate set in Register 3.

The PN9 sequence is suitable for test modulation when carrying out adjacent channel power (ACP) or occupied bandwidth measurements.

Table 12. Transmit Test Pattern Generator Options

Test Pattern	Register 15, Bits[DB10:DB8]
Normal	000
Transmit carrier only	001
Transmit +f _{DEV} tone only	010
Transmit -f _{DEV} tone only	011
Transmit 1010 pattern	100
Transmit PN9 sequence	101
Transmit SWD pattern repeatedly	110

RECEIVER SECTION

RF FRONT END

The ADF7021-V is based on a fully integrated, low IF receiver architecture. The low IF architecture facilitates a very low external component count and does not suffer from powerline-induced interference problems.

Figure 44 shows the structure of the receiver front end. The many programming options allow users to trade off sensitivity, linearity, and current consumption to best suit their application. To achieve a high level of resilience against spurious reception, the low noise amplifier (LNA) features a differential input. Switch SW2 shorts the LNA input when transmit mode is selected (Register 0, Bit DB27 = 0). This feature facilitates the design of a combined LNA/PA matching network, avoiding the need for an external Tx/Rx switch. See the LNA/PA Matching section for details on the design of the matching network.

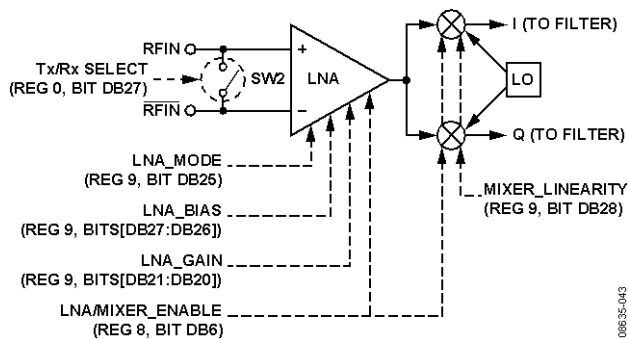

Figure 44. RF Front End

The LNA is followed by a quadrature downconversion mixer, which converts the RF signal to the IF frequency of 100 kHz. An important consideration is that the output frequency of the synthesizer must be programmed to a value 100 kHz below the center frequency of the received channel. The LNA has two basic operating modes: high gain/low noise mode and low gain/low power mode. To switch between these two modes, use the LNA_MODE bit (Register 9, Bit DB25). The mixer is also configurable for either a low current mode or an enhanced linearity mode using the MIXER_LINEARITY bit (Register 9, Bit DB28).

Based on the specific sensitivity and linearity requirements of the application, it is recommended that the LNA_MODE bit and the MIXER_LINEARITY bit be adjusted as shown in Table 14. The gain of the LNA is configured by the LNA_GAIN bits (Register 9, Bits[DB21:DB20]) and can be set by the user or by the automatic gain control (AGC) logic.

IF FILTER

IF Filter Settings

Out-of-band interference is rejected by means of a fifth-order Butterworth polyphase IF filter centered on a frequency of 100 kHz. The bandwidth of the IF filter can be programmed to 9 kHz, 13.5 kHz, or 18.5 kHz in Register 4, Bits[DB31:DB30]; choose the filter value as a compromise between interference rejection and attenuation of the desired signal.

If the AGC loop is disabled, the gain of the IF filter can be set to one of three levels by using the FILTER_GAIN bits (Register 9, Bits[DB23:DB22]). The filter gain is adjusted automatically if the AGC loop is enabled.

IF Filter Bandwidth and Center Frequency Calibration

To compensate for manufacturing tolerances, calibrate the IF filter after power-up to ensure that the bandwidth and center frequency are correct. Coarse and fine calibration schemes are provided to offer a choice between fast calibration (coarse calibration) and high filter centering accuracy (fine calibration). Coarse calibration is enabled by setting Register 5, Bit DB4 high. Fine calibration is enabled by setting Register 6, Bit DB4 high.

For details on when it is necessary to perform a filter calibration, and in what applications to use either a coarse calibration or fine calibration, see the IF Filter Bandwidth Calibration section.

RSSI/AGC

The RSSI is implemented as a successive compression log amp following the baseband (BB) channel filtering. The log amp achieves ± 3 dB log linearity. It also doubles as a limiter to convert the signal-to-digital levels for the FSK demodulator. The offset correction circuit uses the BBOS_CLK_DIVIDE bits (Bits DB5:DB4) in Register 3) and must be set between 1 MHz and 2 MHz. The RSSI level is converted for user readback and for digitally controlled AGC by an 80-level (7-bit) flash ADC. This level can be converted to input power in dBm. By default, the AGC is on when powered up in receive mode.

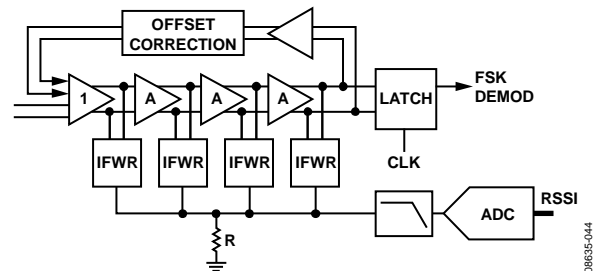

Figure 45. RSSI Block Diagram

RSSI Thresholds

When the RSSI is above AGC_HIGH_THRESHOLD (Register 9, Bits[DB17:DB11]), the gain is reduced. When the RSSI is below AGC_LOW_THRESHOLD (Register 9, Bits[DB10:DB4]), the gain is increased. The thresholds default to 70 (high threshold) and 30 (low threshold) on power-up in receive mode. A delay (set by AGC_CLK_DIVIDE in Register 3, Bits[DB31:DB26]) is programmed to allow for settling of the loop. A value of 33 is recommended to give an AGC update rate of 3 kHz.

The user has the option of changing the two threshold values from the defaults of 70 and 30 (Register 9). Ensure that the default AGC setup values are adequate for most applications. The threshold values must be more than 30 apart for the AGC to operate correctly.

Offset Correction Clock

In Register 3, set the BBOS_CLK_DIVIDE bits (Bits[DB5:DB4]) to give a baseband offset clock (BBOS CLK) frequency between 1 MHz and 2 MHz.

$$BBOS\ CLK\ (Hz) = XTAL / (BBOS_CLK_DIVIDE)$$

where BBOS_CLK_DIVIDE can be set to 4, 8, 16, or 32.

AGC Information and Timing

AGC is selected by default and operates by setting the appropriate LNA and filter gain settings for the measured RSSI level. To enter one of the LNA/mixer modes listed in Table 14, the user can disable AGC by writing to Register 9. After each gain change, the AGC loop waits for a programmed time to allow transients to settle. This AGC update rate is set according to

$$AGC\ Update\ Rate\ (Hz) = \frac{SEQ_CLK_DIVIDE(Hz)}{AGC_CLK_DIVIDE}$$

where:

SEQ_CLK_DIVIDE = 100 kHz (Register 3, Bits[DB25:DB18]).
 AGC_CLK_DIVIDE is set by Register 3, Bits[DB31:DB26]. A value of 33 is recommended.

It is recommended that AGC_CLK_DIVIDE be set to a value of 33, which allows a settling time of 333 μs for each gain change. By using the recommended setting for AGC_CLK_DIVIDE, the total AGC settling time is

$$AGC\ Settling\ Time(sec) = \frac{Number\ of\ AGC\ Gain\ Changes}{AGC\ Update\ Rate(Hz)}$$

Table 14. LNA/Mixer Modes (Register 9 Settings)

Receiver Mode	LNA_MODE (Bit DB25)	LNA_GAIN (Bits[DB21:DB20])	MIXER_LINEARITY (Bit DB28)	Sensitivity (2FSK, Data Rate = 4.8 kbps, f _{DEV} = 4 kHz) (dBm)	Rx Current Consumption (mA)	Input IP3 (dBm)
High Sensitivity Mode (Default)	0	+30	0	-116.5	+20.1	-24
Enhanced Linearity, High Gain	0	+30	+1	-113	+20.1	-20
Medium Gain	+1	+10	0	-108	+17.9	-13.5
Enhanced Linearity, Medium Gain	+1	+10	+1	-102	+17.9	-9
Low Gain	+1	+3	0	-99	+17.9	-5
Enhanced Linearity, Low Gain	+1	+3	+1	-91	+17.9	-3

The total AFC settling time depends on the number of AGC gain changes during reception of a packet. A total of five gain changes gives a worst-case AGC settling time of 5 × 333 μs. To allow for AGC settling, adjust the preamble length accordingly.

RSSI Formula (Converting to dBm)

The RSSI formula is

$$Input\ Power\ (dBm) = -130\ dBm + (Readback\ Code + Gain\ Mode\ Correction) \times 0.5$$

where:

Readback Code is given by Bit RV7 to Bit RV1 in the readback register (see Figure 57 and the Readback Format section).

Gain Mode Correction is given by the values in Table 13.

The LNA gain (LG2, LG1) and filter gain (FG2, FG1) values are also obtained from the readback register, as part of an RSSI readback.

Table 13. Gain Mode Correction

LNA Gain (LG2, LG1)	Filter Gain (FG2, FG1)	Gain Mode Correction
H (1, 0)	H (1, 0)	0
M (0, 1)	H (1, 0)	24
M (0, 1)	M (0, 1)	38
M (0, 1)	L (0, 0)	58
L (0, 0)	L (0, 0)	86

Introduce an additional factor to account for losses in the front-end-matching network/antenna.

DEMODULATION, DETECTION, AND CDR

System Overview

An overview of the demodulation, detection, and clock and data recovery (CDR) of the received signal on the ADF7021-V is shown in Figure 46.

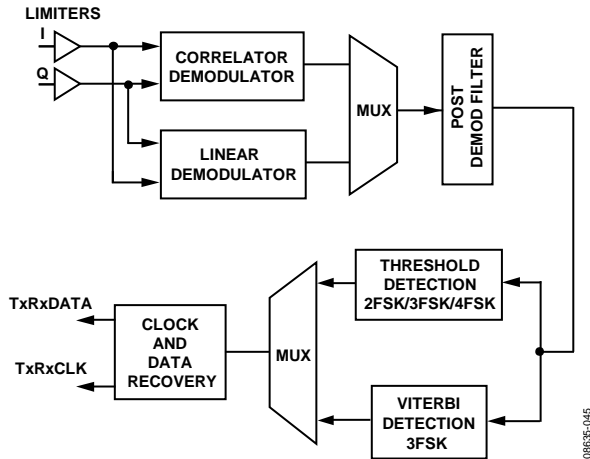

Figure 46. Overview of Demodulation, Detection, and CDR Process

The quadrature outputs of the IF filter are first limited and then fed to either the correlator FSK demodulator or to the linear FSK demodulator. The correlator demodulator is used to demodulate 2FSK, 3FSK, and 4FSK. The linear demodulator is used for frequency measurement and is enabled when the AFC loop is active. The linear demodulator can also be used to demodulate 2FSK.

Following the demodulator, a digital postdemodulator filter removes excess noise from the demodulator signal output. Threshold/slicer detection is used for data recovery of 2FSK and 4FSK. Data recovery of 3FSK can be implemented using either threshold detection or Viterbi detection.

An on-chip CDR PLL is used to resynchronize the received bit stream to a local clock. It outputs the retimed data and clock on the TxRxDATA and TxRxCLK pins, respectively.

Correlator Demodulator

The correlator demodulator can be used for 2FSK, 3FSK, and 4FSK demodulation. Figure 47 shows the operation of the correlator demodulator for 2FSK.

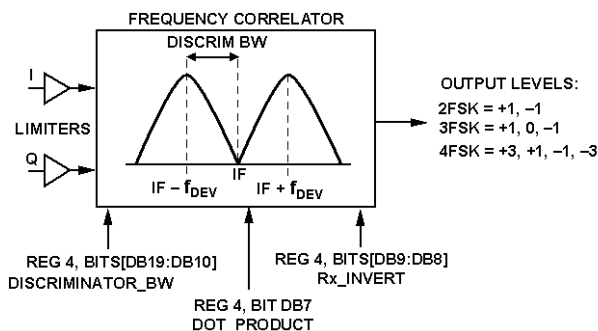

Figure 47. 2FSK Correlator FSK Demodulator Operation

The quadrature outputs of the IF filter are first limited and then fed to a digital frequency correlator that performs filtering and frequency discrimination of the 2FSK/3FSK/4FSK spectrum.

For 2FSK modulation, data is recovered by comparing the output levels from two correlators. The performance of this frequency discriminator approximates that of a matched filter detector, which is known to provide optimum detection in the presence of additive white Gaussian noise (AWGN). This method of FSK demodulation provides approximately 3 dB to 4 dB better sensitivity than a linear demodulator.

Linear Demodulator

Figure 48 shows a block diagram of the linear demodulator.

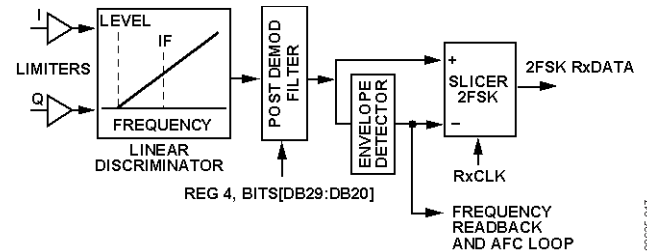

Figure 48. Block Diagram of Linear FSK Demodulator

A digital frequency discriminator provides an output signal that is linearly proportional to the frequency of the limiter outputs. The discriminator output is filtered and averaged using a combined averaging filter and envelope detector. The demodulated 2FSK data from the postdemodulator filter is recovered by slicing against the output of the envelope detector, as shown in Figure 48. This method of demodulation corrects for frequency errors between the transmitter and receiver when the received spectrum is close to or within the IF bandwidth. This envelope detector output is also used for AFC readback and provides the frequency estimate for the AFC control loop.

Postdemodulator Filter

A second-order, digital low-pass filter removes excess noise from the demodulated bit stream at the output of the discriminator. The bandwidth of this postdemodulator filter is programmable and must be optimized for the user's data rate and the received modulation type. If the bandwidth is too narrow, performance degrades due to intersymbol interference (ISI). If the bandwidth is too wide, excess noise degrades the performance of the receiver. The POST_DEMOD_BW bits (Register 4, Bits[DB29:DB20]) set the bandwidth of this filter.

2FSK Bit Slicer/Threshold Detection

2FSK demodulation can be implemented using the correlator FSK demodulator or the linear FSK demodulator. In both cases, threshold detection is used for data recovery at the output of the postdemodulator filter.

The output signal levels of the correlator demodulator are always centered about 0. Therefore, the slicer threshold level can be fixed at 0, and the demodulator performance is independent of the run-length constraints of the transmit data bit stream. This results in robust data recovery that does not suffer from the classic baseline wander problems that exist in more traditional FSK demodulators.

When the linear demodulator is used for 2FSK demodulation, the output of the envelope detector is used as the slicer threshold, and this output tracks frequency errors that are within the IF filter bandwidth.

3FSK and 4FSK Threshold Detection

4FSK demodulation is implemented using the correlator demodulator followed by the postdemodulator filter and threshold detection. The output of the postdemodulator filter is a four-level signal that represents the transmitted symbols (-3, -1, +1, +3). Threshold detection of 4FSK requires three threshold settings: one that is always fixed at 0 and two that are programmable and are symmetrically placed above and below 0 using the 3FSK/4FSK_SLICER_THRESHOLD bits (Register 13, Bits[DB10:DB4]).

3FSK demodulation is implemented using the correlator demodulator, followed by a postdemodulator filter. The output of the postdemodulator filter is a three-level signal that represents the transmitted symbols (-1, 0, +1). Data recovery of 3FSK can be implemented using threshold detection or Viterbi detection. Threshold detection is implemented using two thresholds that are programmable and are symmetrically placed above and below 0 using the 3FSK/4FSK_SLICER_THRESHOLD bits (Register 13, Bits[DB10:DB4]).

3FSK Viterbi Detection

Viterbi detection of 3FSK operates on a four-state trellis and is implemented using two interleaved Viterbi detectors operating at half the symbol rate. The Viterbi detector is enabled by Register 13, Bit DB11.

To facilitate different run-length constraints in the transmitted bit stream, the Viterbi path memory length is programmable in steps of 4 bits, 6 bits, 8 bits, or 32 bits by setting the VITERBI_PATH_MEMORY bits (Register 13, Bits[DB14:DB13]). Set this value equal to or greater than the maximum number of consecutive 0s in the interleaved transmit bit stream.

When used with Viterbi detection, the receiver sensitivity for 3FSK is typically 3 dB greater than that obtained using threshold detection. When the Viterbi detector is enabled, however, the receiver bit latency is increased by twice the Viterbi path memory length.

Clock and Data Recovery (CDR)

An oversampled digital clock and data recovery (CDR) PLL is used to resynchronize the received bit stream to a local clock in all modulation modes. The oversampled clock rate of the PLL (CDR CLK) must be set at 32 times the symbol rate (see the Register 3—Transmit/Receive Clock Register section). The maximum data/symbol rate tolerance of the CDR PLL is determined by the number of zero-crossing symbol transitions in the transmitted packet. For example, if using 2FSK with a 101010 preamble, a maximum tolerance of $\pm 3.0\%$ of the data rate is achieved. However, this tolerance is reduced during recovery of the remainder of the packet, where symbol transitions may not be guaranteed to occur at regular intervals. To maximize the data rate tolerance of the CDR, some form of encoding and/or data scrambling is recommended that guarantees a number of transitions at regular intervals.

For example, using 2FSK with Manchester-encoded data achieves a data rate tolerance of $\pm 2.0\%$.

The CDR PLL is designed for fast acquisition of the recovered symbols during preamble and typically achieves bit synchronization within five-symbol transitions of preamble.

In 4FSK modulation, the tolerance using the +3, -3, +3, -3 preamble is $\pm 3\%$ of the symbol rate (or $\pm 1.5\%$ of the data rate). However, this tolerance is reduced during recovery of the remainder of the packet, where symbol transitions may not be guaranteed to occur at regular intervals. To maximize the symbol/data rate tolerance of the CDR, construct the remainder of the 4FSK packet so that the transmitted symbols retain close to dc-free properties by using data scrambling and/or by inserting specific dc-balancing symbols into the transmitted bit stream at regular intervals, such as after every 8 or 16 symbols.

In 3FSK modulation, the linear convolutional encoder scheme guarantees that the transmitted symbol sequence is dc-free, facilitating symbol detection. However, Tx data scrambling is recommended to limit the run length of 0 symbols in the transmit bit stream. Using 3FSK, the CDR data rate tolerance is typically $\pm 0.5\%$.

RECEIVER SETUP

Correlator Demodulator Setup

To enable the correlator for various modulation modes, see Table 15.

Table 15. Enabling the Correlator Demodulator

Received Modulation	DEMOM_SCHEME (Register 4, Bits[DB6:DB4])
2FSK	001
3FSK	010
4FSK	011

To optimize receiver sensitivity, the correlator bandwidth must be optimized for the specific deviation frequency and modulation used by the transmitter. The discriminator bandwidth is controlled by Register 4, Bits[DB19:DB10], and is defined as

$$DISCRIMINATOR_BW = \frac{(DEMOMCLK \times K)}{400 \times 10^3}$$

where:

DEMOM CLK is as defined in the Register 3—Transmit/Receive Clock Register section.

K is set for each modulation mode as follows:

For 2FSK,

$$K = Round\left(\frac{100 \times 10^3}{f_{DEV}}\right)$$

For 3FSK,

$$K = Round\left(\frac{100 \times 10^3}{2 \times f_{DEV}}\right)$$

For 4FSK,

$$K = Round_{4FSK}\left(\frac{100 \times 10^3}{4 \times f_{DEV}}\right)$$

where:

Round is rounded to the nearest integer.

Round_{4FSK} is rounded to the nearest of the following integers:

32, 31, 28, 27, 24, 23, 20, 19, 16, 15, 12, 11, 8, 7, 4, 3.

f_{DEV} is the transmit frequency deviation in Hz. For 4FSK, f_{DEV} is the frequency deviation used for the ±1 symbols (that is, the inner frequency deviations).

To optimize the coefficients of the correlator, Register 4, Bit DB7 and Register 4, Bits[DB9:DB8] must also be assigned. The value of these bits depends on whether K is odd or even. These bits are assigned according to Table 16 and Table 17.

Table 16. Assignment of Correlator K Value for 2FSK and 3FSK

K	K/2	(K + 1)/2	Register 4, Bit DB7	Register 4, Bits[DB9:DB8]
Even	Even	N/A	0	00
Even	Odd	N/A	0	10
Odd	N/A	Even	1	00
Odd	N/A	Odd	1	10

Table 17. Assignment of Correlator K Value for 4FSK

K	Register 4, Bit DB7	Register 4, Bits[DB9:DB8]
Even	0	00
Odd	1	00

Linear Demodulator Setup

The linear demodulator can be used for 2FSK demodulation. To enable the linear demodulator, set the DEMOM_SCHEME bits (Register 4, Bits[DB6:DB4]) to 000.

Postdemodulator Filter Setup

Set the 3 dB bandwidth of the postdemodulator filter according to the received modulation type and data rate. The bandwidth is controlled by Register 4, Bits[DB29:DB20] and is given by

$$POST_DEMOM_BW = \frac{2^{11} \times \pi \times f_{CUTOFF}}{DEMOMCLK}$$

where f_{CUTOFF} is the target 3 dB bandwidth in Hz of the post-demodulator filter. Round up POST_DEMOM_BW to the nearest integer value.

Table 18. Postdemodulator Filter Bandwidth Settings for 2FSK/3FSK/4FSK Modulation Schemes

Received Modulation	Postdemodulator Filter Bandwidth, f _{CUTOFF} (Hz)
2FSK	0.75 × data rate
3FSK	1 × data rate
4FSK	1.6 × symbol rate (0.8 × data rate)

3FSK Viterbi Detector Setup

The Viterbi detector can be used for 3FSK data detection; it is activated by setting Register 13, Bit DB11, to Logic 1.

The Viterbi path memory length is programmable in steps of 4, 6, 8, or 32 bits (VITERBI_PATH_MEMORY, Register 13, Bits[DB14:DB13]). Set the path memory length equal to or greater than the maximum number of consecutive 0s in the interleaved transmit bit stream.

The Viterbi detector also uses threshold levels to implement the maximum likelihood detection algorithm. These thresholds are programmable via the 3FSK/4FSK_SLICER_THRESHOLD bits (Register 13, Bits[DB10:DB4]).

These bits are assigned as follows:

3FSK/4FSK_SLICER_THRESHOLD =

$$57 \times \left(\frac{Tx_FREQUENCY_DEVIATION \times K}{100 \times 10^3} \right)$$

where K is the value calculated for correlator discriminator bandwidth.

3FSK Threshold Detector Setup

To activate threshold detection of 3FSK, set Register 13, Bit DB11, to Logic 0. Set the 3FSK/4FSK_SLICER_THRESHOLD bits (Register 13, Bits[DB10:DB4]) as described in the 3FSK Viterbi Detector Setup section.

3FSK CDR Setup

In 3FSK, a transmit preamble of at least 40 bits of continuous 1s is recommended to ensure a maximum number of symbol transitions for the CDR to acquire lock.

The clock and data recovery for 3FSK requires a number of parameters in Register 13 to be set (see Table 19).

4FSK Threshold Detector Setup

The threshold for the 4FSK detector is set using the 3FSK/4FSK_SLICER_THRESHOLD bits (Register 13, Bits[DB10:DB4]). Set the threshold as follows:

$$3FSK/4FSK_SLICER_THRESHOLD = 78 \times \left(\frac{4FSK\ Outer\ Tx\ Deviation \times K}{100 \times 10^3} \right)$$

where *K* is the value calculated for correlator discriminator bandwidth.

FSK DEMODULATOR OPTIMIZATION

2FSK Preamble

The recommended preamble bit pattern for 2FSK, GFSK, and RC2FSK is a dc-free pattern (such as a 10101010... pattern). Preamble patterns with longer run-length constraints (such as

11001100...) can also be used, but result in a longer synchronization time of the received bit stream in the receiver. The preamble must allow enough bits for AGC settling of the receiver and CDR acquisition (see Table 20).

The remaining fields that follow the preamble do not need to use dc-free coding. For these fields, the ADF7021-V can accommodate coding schemes with a run length of greater than eight bits without any performance degradation. Refer to the AN-915 Application Note for more information.

4FSK Preamble and Data Coding

The recommended preamble bit pattern for 4FSK is a repeating 00100010... bit sequence. This two-level sequence of repeating -3, +3, -3, +3 symbols is dc-free and maximizes the symbol timing performance and data recovery of the 4FSK preamble in the receiver. The minimum recommended length of the preamble is 32 bits (16 symbols).

Construct the remainder of the 4FSK packet so that the transmitted symbols retain close to a dc-free balance by using data scrambling and/or by inserting specific dc-balancing symbols in the transmitted bit stream at regular intervals, such as after every 8 or 16 symbols.

Table 19. 3FSK CDR Settings

Parameter (Register 13)	Recommended Setting	Purpose
PHASE_CORRECTION (Bit DB12)	1	Phase correction is on
3FSK_CDR_THRESHOLD (Bits[DB21:DB15])	$62 \times \left(\frac{Tx_FREQUENCY_DEVIATION \times K}{100 \times 10^3} \right)$ where <i>K</i> is the value calculated for correlator discriminator bandwidth.	Sets CDR decision threshold levels
3FSK_PREAMBLE_TIME_VALIDATE (Bits[DB25:DB22])	15	Preamble detector time qualifier

Table 20. Preamble Bit Length for 2FSK Modulation

Demodulator	Sensitivity Degradation from Specifications	Rx Frequency Error Tolerance (1% PER)	Minimum Preamble (Bits)
Correlator (AFC off)			
Mod index = 2	0 dB	$\pm 30\% \times f_{DEV}$	16
Mod index = 1	0 dB	$\pm 25\% \times f_{DEV}$	16
Mod index = 0.5	0 dB	$\pm 20\% \times f_{DEV}$	16
Linear (AFC off)			
$f_{DEV} = 4.2$ kHz	3 dB	$\pm 0.5 \times IFBW^1$	64
$f_{DEV} = 2.2$ kHz	3 dB	$\pm 0.5 \times IFBW^1$	112
$f_{DEV} = 1.6$ kHz	3 dB	$\pm 0.5 \times IFBW^1$	128
Correlator (AFC on)	2 dB	AFC pull-in range ²	96 to 128 ³
Linear (AFC on)	3 dB	AFC pull-in range ²	96 to 128
Correlator + bypass CDR (AFC off)	2 dB to 3 dB ⁴	$\pm 50\% \times f_{DEV}^5$	8

¹ This value is generally true; however, some sensitivity degradation may occur close to the edge of the IF filter.

² Limited to $\pm 0.5 \times IFBW$ or AFC pull-in range, whichever is less.

³ Dependent on modulation index and f_{DEV} . At higher modulation indexes (1.0 or greater) and higher f_{DEV} (>4.0 kHz), the minimum preamble length is 96 bits. The minimum preamble length increases as the modulation index and f_{DEV} are reduced.

⁴ Dependent on the performance of the symbol timing recovery module on the external microcontroller.

⁵ Depends on the pulse width mark/space ratio of Logic 1 to Logic 0 that the symbol timing recovery scheme on the external microcontroller can tolerate. In this mode, the mark/space ratio of the recovered bit stream increases with frequency error. In the absence of frequency error, the mark/space ratio is 50:50, that is, the width of a Logic 1 is the same as the width of a Logic 0.

Correlator Demodulator and Low Modulation Indexes

The modulation index in 2FSK is defined as

$$\text{ModulationIndex} = \frac{2 \times f_{DEV}}{\text{Data Rate}}$$

The receiver sensitivity performance and receiver frequency tolerance can be maximized at low modulation indexes by increasing the discriminator bandwidth of the correlator demodulator. For modulation indexes of less than 0.4, it is recommended that the correlator bandwidth be doubled by calculating K as follows:

$$K = \text{Round} \left(\frac{100^3}{2 \times f_{DEV}} \right)$$

Recalculate the DISCRIMINATOR_BW value in Register 4 using the new K value. Figure 29 illustrates the improved sensitivity that can be achieved for 2FSK modulation, at low modulation indexes, by doubling the correlator bandwidth.

AFC OPERATION

The ADF7021-V also supports a real-time AFC loop that is used to remove frequency errors due to mismatches between the transmit and receive crystals/TCXOs. The AFC loop uses the linear frequency discriminator block to estimate frequency errors. The linear FSK discriminator output is filtered and averaged to remove the FSK frequency modulation using a combined averaging filter and envelope detector. In receive mode, the output of the envelope detector provides an estimate of the average IF frequency.

The two methods of AFC supported on the ADF7021-V are external AFC and internal AFC.

External AFC

With external AFC, the user reads back the frequency information through the ADF7021-V serial port and applies a frequency correction value to the synthesizer-N divider.

The frequency information is obtained by reading the signed, 16-bit AFC readback value, as described in the Readback Format section, and by applying the following formula:

$$\text{Frequency Readback (Hz)} = (\text{AFC READBACK} \times \text{DEMODO CLK}) / 2^{18}$$

Although the AFC readback value is a signed number, under normal operating conditions, it is positive. In the absence of frequency errors, the frequency readback value is equal to the IF frequency of 100 kHz.

Internal AFC

The ADF7021-V supports a real-time, internal, automatic frequency control loop. In this mode, an internal control loop automatically monitors the frequency error and adjusts the synthesizer-N divider using an internal proportional integral (PI) control loop.

The internal AFC control loop parameters are controlled in Register 10. The internal AFC loop is activated by setting Bit DB4 in Register 10 to 1. A scaling coefficient must also be entered, based on the crystal frequency in use. This is set up using Bits[DB16:DB5] in Register 10 and is calculated as follows:

$$\text{AFC_SCALING_FACTOR} = \text{Round} \left(\frac{2^{24} \times 500}{\text{XTAL}} \right)$$

Maximum AFC Range

The maximum frequency correction range of the AFC loop is programmable using Register 10, Bits[DB31:DB24]. The maximum AFC correction range is the difference in frequency between the upper and lower limits of the AFC tuning range. For example, if the maximum AFC correction range is set to 10 kHz, the AFC can adjust the receiver LO within the $f_{LO} \pm 5$ kHz range.

However, when RF_DIVIDE_BY_2 (Register 1, Bit DB18) is enabled, the programmed range is halved. Account for this halving by doubling the programmed maximum AFC range.

The recommended maximum AFC correction range is $\leq 1.5 \times$ IF filter bandwidth. If the maximum frequency correction range is set to be $> 1.5 \times$ IF filter bandwidth, the attenuation of the IF filter can degrade the AFC loop sensitivity.

The adjacent channel rejection (ACR) performance of the receiver can be degraded when AFC is enabled and the AFC correction range is close to or greater than the IF filter bandwidth. However, because the AFC correction range is programmable, the user can trade off AFC correction range and ACR performance of the receiver.

When AFC errors are removed using either the internal or external AFC, further improvement in receiver sensitivity can be obtained by reducing the IF filter bandwidth using the IF_FILTER_BW bits (Register 4, Bits[DB31:DB30]).

AUTOMATIC SYNC WORD DETECTION (SWD)

The ADF7021-V also supports automatic detection of the sync or ID fields. To activate this mode, the sync (or ID) word must be preprogrammed into the ADF7021-V. In receive mode, this preprogrammed word is compared to the received bit stream. When a valid match is identified, the external SWD pin is asserted by the ADF7021-V on the next Rx clock pulse.

This feature can be used to alert the microprocessor that a valid channel has been detected. It relaxes the computational requirements of the microprocessor and reduces the overall power consumption.

The SWD signal can also be used to frame the received packet by staying high for a preprogrammed number of bytes. The data packet length can be set in Register 12, Bits[DB15:DB8].

The SWD pin status can be configured by setting Bits[DB7:DB6] in Register 12. Bits[DB5:DB4] in Register 11 are used to set the length of the sync/ID word, which can be 12, 16, 20, or 24 bits long. A value of 24 bits is recommended to minimize false sync word detection in the receiver that can occur during recovery of the remainder of the packet or when a noise/no signal is present at the receiver input. The transmitter must transmit the sync byte MSB first, LSB last to ensure proper alignment in the receiver sync-byte-detection hardware.

An error tolerance parameter can also be programmed that accepts a valid match when up to three bits of the word are incorrect. The error tolerance value is assigned in Register 11, Bits[DB7:DB6].

APPLICATIONS INFORMATION

IF FILTER BANDWIDTH CALIBRATION

Calibrate the IF filter on every power-up in receive mode to correct for errors in the bandwidth and filter center frequency due to process variations. The automatic calibration requires no external intervention when it is initiated by a write to Register 5. Depending on numerous factors, such as IF filter bandwidth, received signal bandwidth, and temperature variation, the user must determine whether to carry out a coarse calibration or a fine calibration.

The performance of both calibration methods is shown in Table 21.

Table 21. IF Filter Calibration Specifications

Filter Calibration Method	Center Frequency Accuracy ¹	Calibration Time (Typ)
Coarse Calibration	100 kHz ± 2.5 kHz	200 μs
Fine Calibration	100 kHz ± 0.6 kHz	8.2 ms

¹ After calibration.

Calibration Setup

IF filter calibration is initiated by writing to Register 5 and setting the IF_CAL_COARSE bit (Bit DB4). This initiates a coarse filter calibration. If the IF_FINE_CAL bit (Register 6, Bit DB4) has already been set high, the coarse calibration is followed by a fine calibration; otherwise, the calibration ends.

When initiated by writing to the part, calibration is performed automatically without user intervention. The calibration time is 200 μs for coarse calibration and 8.2 ms for fine calibration, during which time the ADF7021-V must not be accessed. The IF filter calibration logic requires that the IF_FILTER_DIVIDER bits (Register 5, Bits[DB13:DB5]) be set such that

$$\frac{XTAL(\text{Hz})}{IF_FILTER_DIVIDER} = 50\text{kHz}$$

The fine calibration uses two internally generated tones at certain offsets around the IF filter. The two tones are attenuated by the IF filter, and the level of this attenuation is measured using the RSSI. The filter center frequency is adjusted to allow equal attenuation of both tones. The attenuation of the two test tones is then remeasured. This process continues for a maximum of 10 RSSI measurements, at which point the calibration algorithm sets the IF filter center frequency to within 0.6 kHz of 100 kHz.

The frequency of these tones is set in Register 6 by the IF_CAL_LOWER_TONE_DIVIDE bits (Bits[DB12:DB5]) and the IF_CAL_UPPER_TONE_DIVIDE bits (Bits[DB20:DB13]), as shown in the following equations.

$$\text{Lower Tone Frequency (kHz)} =$$

$$\frac{XTAL}{IF_CAL_LOWER_TONE_DIVIDE \times 2}$$

$$\text{Upper Tone Frequency (kHz)} =$$

$$\frac{XTAL}{IF_CAL_UPPER_TONE_DIVIDE \times 2}$$

It is recommended that the lower tone and the upper tone be set as shown in Table 22.

Table 22. IF Filter Fine Calibration Tone Frequencies

IF Filter Bandwidth (kHz)	Lower Tone Frequency (kHz)	Upper Tone Frequency (kHz)
9	78.1	116.3
13.5	79.4	116.3
18.5	78.1	119

Because the filter attenuation is slightly asymmetrical, it is necessary to have a small offset in the filter center frequency to provide near equal rejection at the upper and lower adjacent channels. The calibration tones listed in Table 22 provide this small positive offset in the IF filter center frequency.

In some applications, an offset may not be required, and the user may wish to center the IF filter at 100 kHz exactly. In this case, the user can alter the tone frequencies from those given in Table 22 to adjust the fine calibration result.

The calibration algorithm adjusts the filter center frequency and measures the RSSI 10 times during the calibration. The time for an adjustment plus RSSI measurement is given by

$$IF \text{ Tone Calibration Time} = \frac{IF_CAL_DWELL_TIME}{SEQCLK}$$

It is recommended that the IF tone calibration time be at least 800 μs. The total time for the IF filter fine calibration is given by

$$IF \text{ Filter Fine Calibration Time} = IF \text{ Tone Calibration Time} \times 10$$

When to Use Coarse Calibration

It is recommended that a coarse calibration be performed on every power-up in receive mode. This calibration typically takes 200 μs. The FILTER_CAL_COMPLETE signal from MUXOUT (set using Bits[DB31:DB29] in Register 0) can be used to monitor the filter calibration duration or to signal the end of calibration. Do not access the ADF7021-V during calibration.

When to Use Fine Calibration

In cases where the receive signal bandwidth is very close to the bandwidth of the IF filter, it is recommended that a fine filter calibration be performed every time that the unit powers up in receive mode.

Perform a fine calibration if

$$OBW + \text{Coarse Calibration Variation} > IF_FILTER_BW$$

where:

OBW is the 99% occupied bandwidth of the transmit signal.

Coarse Calibration Variation is 2.5 kHz.

IF_FILTER_BW is set by Register 4, Bits[DB31:DB30].

The FILTER_CAL_COMPLETE signal from MUXOUT (set by Register 0, Bits[DB31:DB29]) can be used to monitor the filter calibration duration or to signal the end of calibration. A coarse filter calibration is automatically performed prior to a fine filter calibration.

When a fine calibration is executed, the LNA is temporarily detached from the receiver chain to ensure that external signals do not affect the calibration.

When to Use Single Fine Calibration

In applications where the receiver powers up numerous times in a short period, it is necessary to perform fine calibration only once, on the initial power-up in receive mode.

After the initial coarse calibration and fine calibration, the result of the fine calibration can be read back through the serial interface using the FILTER_CAL_READBACK result (see the Filter Bandwidth Calibration Readback section). On subsequent power-ups in receive mode, the filter is manually adjusted using the previous fine filter calibration result. This manual adjustment is performed using the IF_FILTER_ADJUST bits (Register 5, Bits[DB19:DB14]).

Only use this method if the successive power-ups in receive mode are over a short duration, during which time there is little variation in temperature (<15°C).

IF Filter Variation with Temperature

When calibrated, the filter center frequency can vary with changes in temperature. If the ADF7021-V is used in an application where it remains in receive mode for a considerable length of time, the user must consider this variation of filter center frequency with temperature. This variation is typically 1 kHz per 20°C, which means that if a coarse filter calibration and fine filter calibration are performed at 25°C, the initial maximum error is ±0.5 kHz, and the maximum possible change in the filter center frequency over temperature (–40°C to +85°C) is ±3.25 kHz. This gives a total error of ±3.75 kHz.

If the receive signal occupied bandwidth is considerably narrower than the IF filter bandwidth, the variation of filter center frequency over the operating temperature range may not be an issue. However, if the IF filter bandwidth is not wide enough to tolerate the variation with temperature, a periodic filter calibration can be performed or, alternatively, the on-chip

temperature sensor can be used to determine when a filter calibration is necessary by monitoring for changes in temperature.

LNA/PA MATCHING

The ADF7021-V exhibits optimum performance in terms of sensitivity, transmit power, and current consumption only if its RF input and output ports are properly matched to the antenna impedance. For cost-sensitive applications, the ADF7021-V is equipped with an internal Tx/Rx switch that facilitates the use of a simple, combined passive LNA/PA matching network. Alternatively, an external Tx/Rx switch such as the ADG919 can be used, which yields a slightly improved receiver sensitivity and lower transmitter power consumption.

Internal Tx/Rx Switch

Figure 49 shows the ADF7021-V in a configuration where the internal Tx/Rx switch is used with a combined LNA/PA matching network. This is the configuration used on the EVAL-ADF7021-VDBxZ evaluation board. For most applications, the slight performance degradation of 1 dB to 2 dB caused by the internal Tx/Rx switch is acceptable, allowing the user to take advantage of the cost-saving potential of this solution. The design of the combined matching network must compensate for the reactance presented by the networks in the Tx and the Rx paths, taking the state of the Tx/Rx switch into consideration.

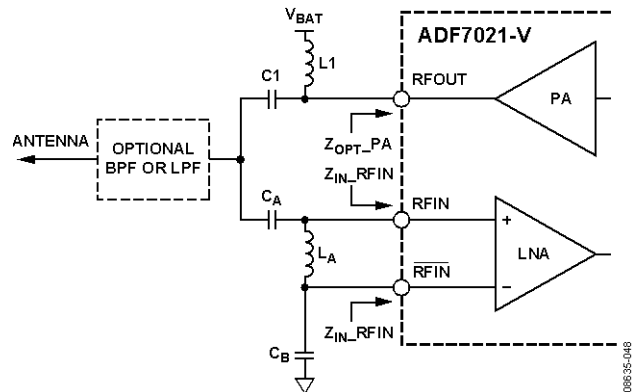

Figure 49. ADF7021-V with Internal Tx/Rx Switch

The procedure typically requires several iterations until an acceptable compromise is reached. The successful implementation of a combined LNA/PA matching network for the ADF7021-V is critically dependent on the availability of an accurate electrical model for the PCB. In this context, the use of a suitable CAD package is strongly recommended. To avoid this effort, a small form-factor reference design for the ADF7021-V is provided, including matching and harmonic filter components. The design is on a 4-layer PCB. Gerber files are available at www.analog.com.

External Tx/Rx Switch

Figure 50 shows a configuration using an external Tx/Rx switch. This configuration allows independent optimization of the matching and filter network in the transmit and receive paths. Therefore, it is more flexible and less difficult to design than the configuration using the internal Tx/Rx switch. The PA is biased through Inductor L1, whereas C1 blocks dc current. Together, L1 and C1 form the matching network that transforms the source impedance into the optimum PA load impedance, Z_{OPT_PA} .

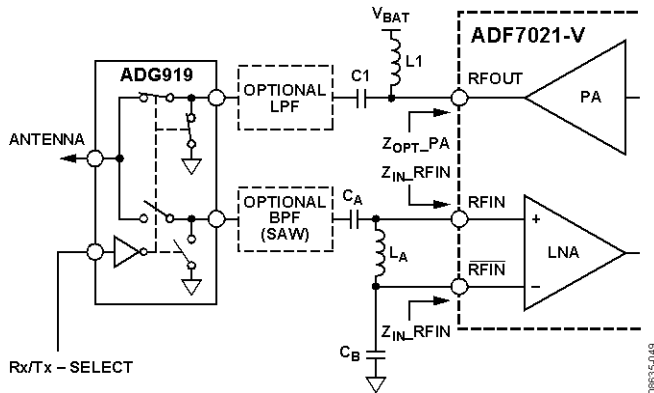

Figure 50. ADF7021-V with External Tx/Rx Switch

Z_{OPT_PA} depends on various factors, such as the required output power, the frequency range, the supply voltage range, and the temperature range. Selecting an appropriate Z_{OPT_PA} helps to minimize the Tx current consumption in the application. The AN-764 Application Note and the AN-859 Application Note contain a number of Z_{OPT_PA} values for representative conditions. Under certain conditions, however, it is recommended that a suitable Z_{OPT_PA} value be obtained by means of a load-pull measurement.

Due to the differential LNA input, the LNA matching network must be designed to provide both a single-ended-to-differential conversion and a complex, conjugate impedance match. The network with the lowest component count that can satisfy these requirements is the configuration shown in Figure 50, consisting of two capacitors and one inductor.

Depending on the antenna configuration, the user may need a harmonic filter at the PA output to satisfy the spurious emission requirement of the applicable government regulations. The harmonic filter can be implemented in various ways, for example, a discrete LC pi or T-stage filter. The immunity of the ADF7021-V to strong out-of-band interference can be improved by adding a band-pass filter in the Rx path. Alternatively, the ADF7021-V blocking performance can be improved by selecting one of the enhanced linearity modes, as described in Table 14.

IMAGE REJECTION CALIBRATION

The image channel in the ADF7021-V is 200 kHz below the desired signal. The polyphase filter rejects this image with an asymmetric frequency response. The image rejection (IR)

performance of the receiver is dependent on how well matched the I and Q signals are in amplitude and how well matched the quadrature is between them (that is, how close to 90° apart they are). The uncalibrated image rejection performance is approximately 29 dB (at 460 MHz). However, it is possible to improve this performance by as much as 20 dB by finding the optimum I/Q gain and phase adjust settings.

Calibration Using Internal RF Source

With the LNA powered off, an on-chip generated, low level RF tone is applied to the mixer inputs. The LO is adjusted to make the tone fall at the image frequency where it is attenuated by the image rejection of the IF filter. The power level of this tone is then measured using the RSSI readback. The I/Q gain and phase adjust DACs (Register 5, Bits[DB31:DB20]) are adjusted and the RSSI is remeasured. This process is repeated until the optimum values for the gain and phase adjust are found that provide the lowest RSSI readback level, thereby maximizing the image rejection performance of the receiver.

Using the internal RF source, the RF frequencies that can be used for image calibration are programmable and are odd multiples of the reference frequency.

Calibration Using External RF Source

IR calibration can also be implemented using an external RF source. The IR calibration procedure is the same as that used for the internal RF source, except that an RF tone is applied to the LNA input.

Calibration Procedure and Setup

The IR calibration algorithm available from Analog Devices, Inc., is based on a low complexity, 2D optimization algorithm that can be implemented in an external microprocessor or microcontroller.

To enable the internal RF source, set the IR_CAL_SOURCE_DRIVE_LEVEL bits (Register 6, Bits[DB29:DB28]) to the maximum level. Set the LNA to its minimum gain setting, and disable the AGC if the internal RF source is being used. Alternatively, an external RF source can be used.

The magnitude of the phase adjust is set using the IR_PHASE_ADJUST_MAG bits (Register 5, Bits[DB23:DB20]). This correction can be applied to either the I or Q channel, depending on the value of the IR_PHASE_ADJUST_DIRECTION bit (Register 5, Bit DB24).

The magnitude of the I/Q gain is adjusted using the IR_GAIN_ADJUST_MAG bits (Register 5, Bits[DB29:DB25]). This correction can be applied to either the I or Q channel, depending on the value of the IR_GAIN_ADJUST_I/Q bit (Register 5, Bit DB30), whereas the IR_GAIN_ADJUST_UP/DN bit (Register 5, Bit DB31) sets whether the gain adjustment defines a gain or an attenuation adjust.

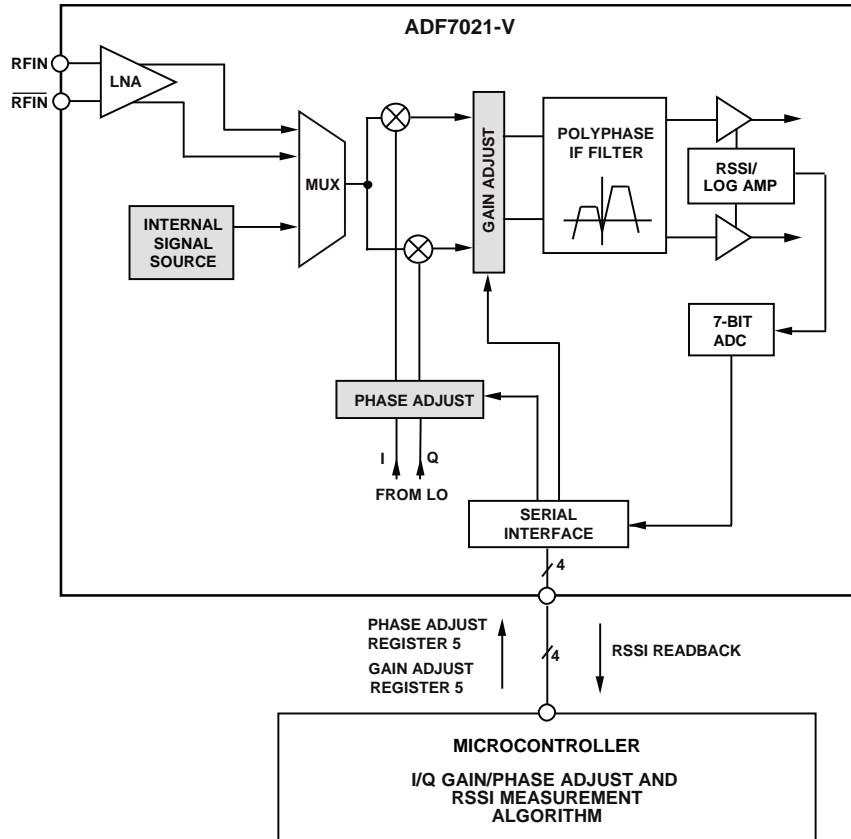

Figure 51. Image Rejection Calibration Using the Internal Calibration Source and a Microcontroller

The calibration results are valid over changes in the ADF7021-V supply voltage. However, there is some variation with temperature. A typical plot of variation in image rejection over temperature after initial calibrations at -40°C, +25°C, and +85°C is shown in Figure 52. The internal temperature sensor on the ADF7021-V can be used to determine whether a new IR calibration is required.

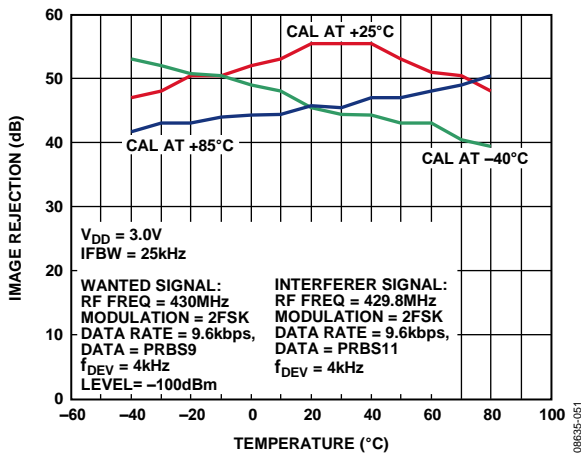

Figure 52. Image Rejection vs. Temperature After Initial Calibrations at -40°C, +25°C, and +85°C

PACKET STRUCTURE AND CODING

The suggested packet structure to use with the ADF7021-V is shown in Figure 53.

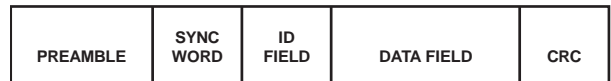

Figure 53. Typical Format of a Transmit Protocol

See the Receiver Setup section for information about the required preamble structure and length for the various modulation schemes.

PROGRAMMING AFTER INITIAL POWER-UP

Table 23 lists the minimum number of writes needed to set up the ADF7021-V in either Tx or Rx mode after CE is brought high for a minimum of 100 μs before programming any register. Additional registers can also be written to tailor the part to a particular application, such as setting up sync byte detection or enabling AFC. When going from Tx to Rx or vice versa, the user needs to toggle the Tx/Rx bit and write only to Register 0 to alter the LO by 100 kHz.

Table 23. Minimum Register Writes Required for Tx/Rx Setup

Mode	Required Register Writes
Tx	Reg 1, Reg 3, Reg 0, Reg 2
Rx	Reg 1, Reg 3, Reg 5, Reg 0, Reg 4
Tx to Rx and Rx to Tx	Reg 0

The recommended programming sequences for transmit and receive are shown in Figure 54 and Figure 55, respectively.

The difference in the power-up routine for a TCXO and XTAL reference is shown in these figures.

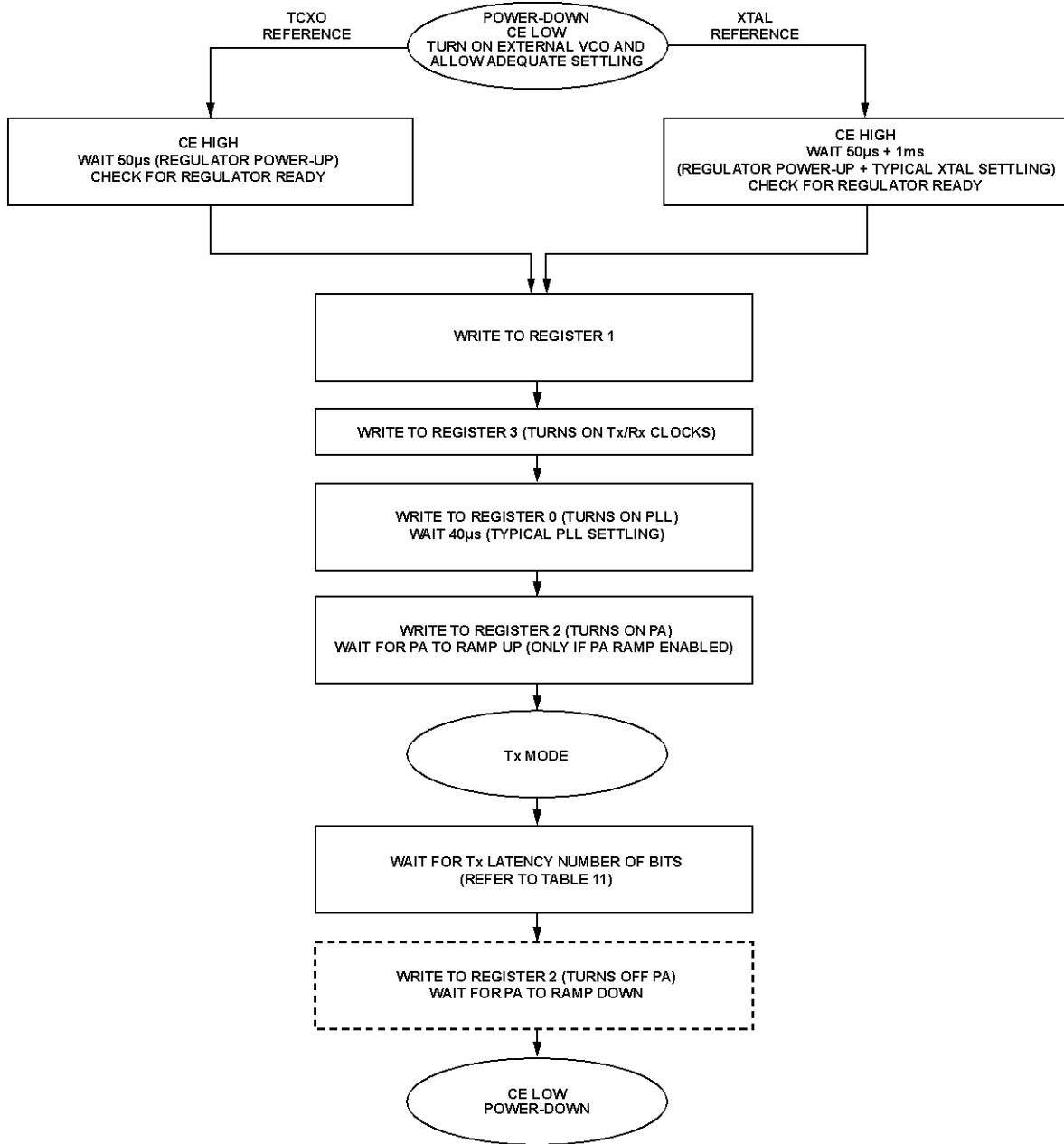

--- OPTIONAL. ONLY NECESSARY IF PA RAMP-DOWN IS REQUIRED.

Figure 54. Power-Up Sequence for Transmit Mode

08835-053

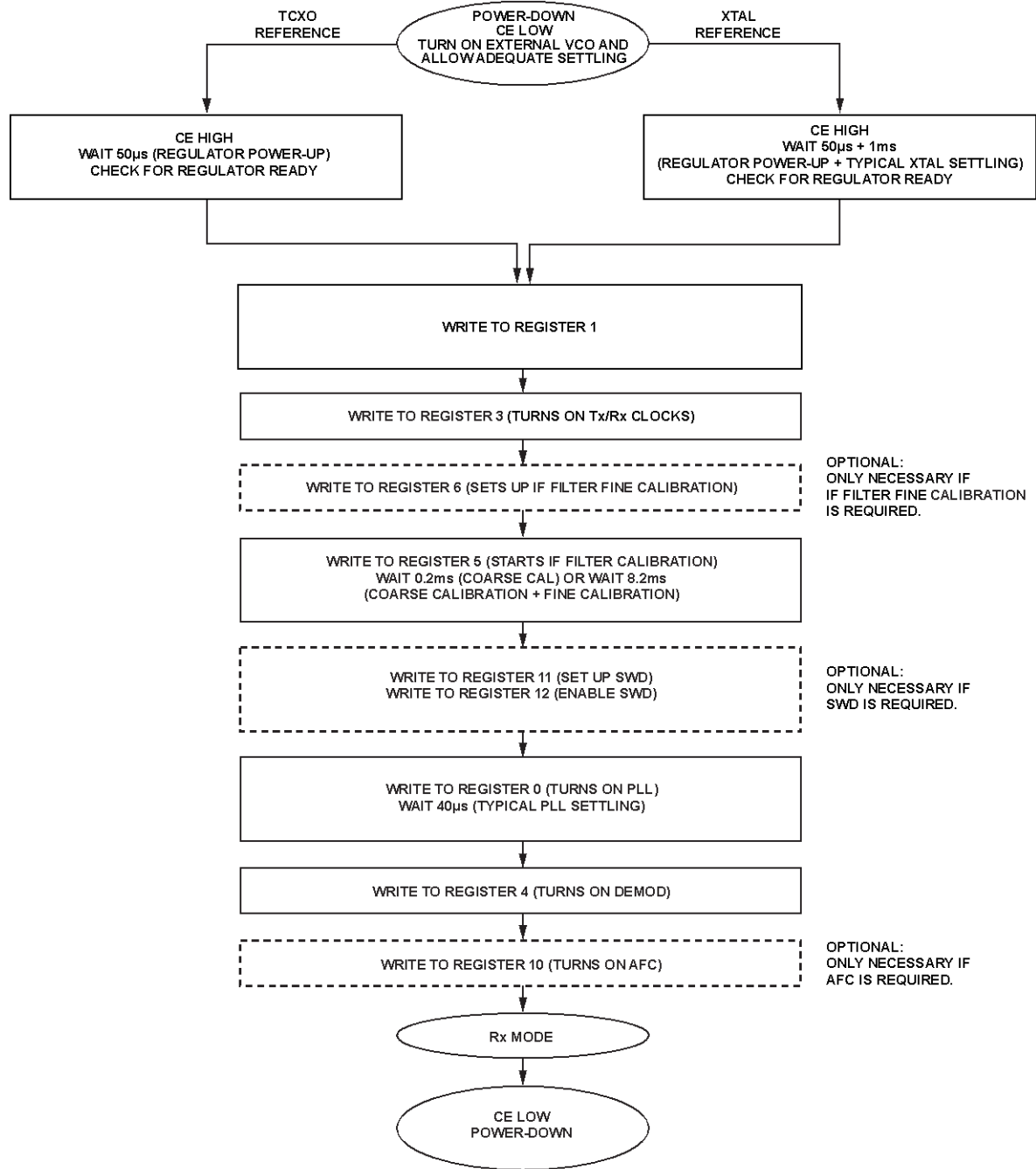

-- OPTIONAL.

Figure 55. Power-Up Sequence for Receive Mode

088-35-054

APPLICATIONS CIRCUIT

The ADF7021-V requires very few external components for operation. Figure 56 shows the recommended application circuit. Note that the power supply decoupling and regulator capacitors are omitted for clarity.

For recommended component values, see the ADF7021-V evaluation board data sheet and the AN-859 Application Note, accessible from the ADF7021-V product page. Follow the reference design schematic closely to ensure optimum performance in narrow-band applications.

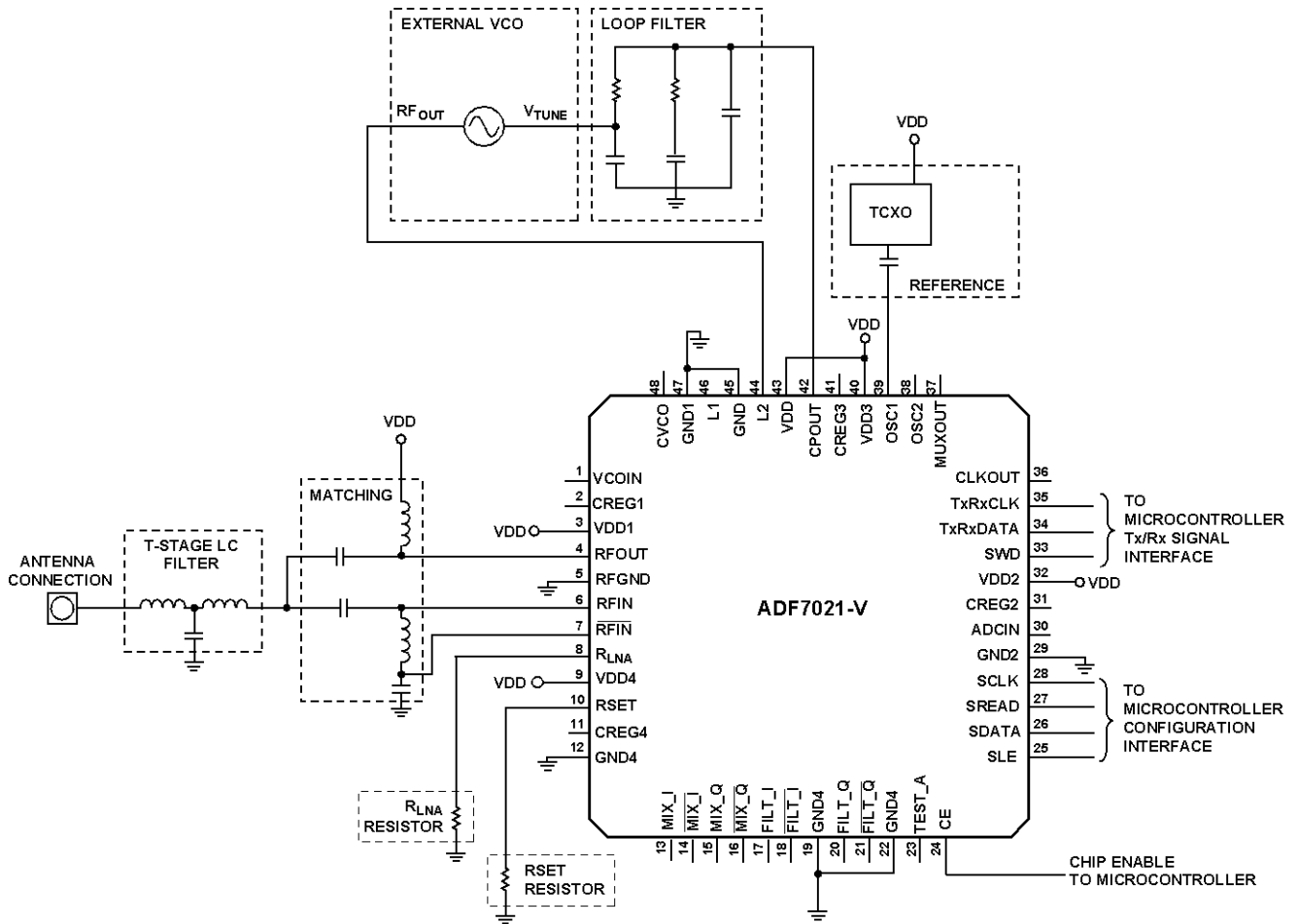

NOTES

1. PINS[13:18], PINS[20:21], AND PIN 23 ARE TEST PINS AND ARE NOT USED IN NORMAL OPERATION.

Figure 56. Typical Application Circuit (Regulator Capacitors and Power Supply Decoupling Not Shown)

086355-055

SERIAL INTERFACE

The serial interface allows the user to program the 16 32-bit registers using a 3-wire interface (SCLK, SDATA, and SLE). It consists of a level shifter, 32-bit shift register, and 16 latches. Signals must be CMOS compatible. The serial interface is powered by the regulator and, therefore, is inactive when CE is low.

Data is clocked into the register, MSB first, on the rising edge of each clock (SCLK). Data is transferred to one of 16 latches on the rising edge of SLE. The destination latch is determined by the value of the four control bits (C4 to C1); these bits are the four LSBs, DB3 to DB0, as shown in Figure 2. Data can also be read back on the SREAD pin.

READBACK FORMAT

The readback operation is initiated by writing a valid control word to the readback setup register and enabling the READBACK_SELECT bit (Register 7, Bit DB8 = 1). The readback can begin after the control word has been latched with the SLE signal. SLE must be kept high while the data is being read out. Each active edge at the SCLK pin successively clocks the readback word out at the SREAD pin, MSB first (see Figure 57). The data appearing at the first clock cycle following the latch operation must be ignored. An extra clock cycle is needed after the 16th readback bit to return the SREAD pin to tristate. Therefore, 18 total clock cycles are needed for each readback. After the 18th clock cycle, bring the SLE low.

AFC Readback

The AFC readback is valid only during the reception of FSK signals with either the linear or correlator demodulator active. The AFC readback value is formatted as a signed, 16-bit integer comprising Bit RV16 to Bit RV1 and is scaled according to the following formula:

$$FREQ\ RB\ (Hz) = (AFC\ READBACK \times DEMOD\ CLK) / 2^{18}$$

In the absence of frequency errors, FREQ RB is equal to the IF frequency of 100 kHz. Note that, for the AFC readback to yield a valid result, the downconverted input signal must not fall outside the bandwidth of the analog IF filter. At low input signal levels, the variation in the readback value can be improved by averaging.

RSSI Readback

The format of the RSSI readback word is shown in Figure 57. It comprises the RSSI-level information (Bit RV7 to Bit RV1), the current filter gain (FG2, FG1), and the current LNA gain (LG2, LG1) setting. The filter and LNA gain are coded in accordance with the definitions in the Register 9—AGC Register section. For signal levels below -100 dBm, averaging the measured RSSI values improves accuracy. The input power can be calculated from the RSSI readback value as described in the RSSI/AGC section.

Readback with AFC or Linear Demodulation On

To perform any readback with the AFC on, the AGC must first be locked. To lock the AGC, use the LOCK_THRESHOLD_MODE bits (Bits[DB5:DB4] in Register 12) for packet reception. The lock threshold mode locks the threshold of the envelope detector, as well as the AFC and AGC circuits. It can be set to lock on reception of a valid SWD and remain locked until it is released by a subsequent SPI command (LOCK_THRESHOLD_MODE = 1). It can also be set to lock on reception of a valid SWD for a specified number of bytes by setting LOCK_THRESHOLD_MODE = 2; or it can be locked at any time by setting LOCK_THRESHOLD_MODE = 3. After the threshold is locked, a readback can be performed. The AGC/AFC lock is released by setting LOCK_THRESHOLD_MODE = 0.

Battery Voltage/ADCIN/Temperature Sensor Readback

The battery voltage is measured at Pin VDD4. The readback information is contained in Bit RV7 to Bit RV1. This also applies to the readback of the voltage at the ADCIN pin and the temperature sensor. From the readback information, the battery or ADCIN voltage can be determined as follows:

$$V_{BATTERY} = (BATTERY\ VOLTAGE\ READBACK) / 21.1$$

$$V_{ADCIN} = (ADCIN\ VOLTAGE\ READBACK) / 42.1$$

The temperature can be calculated as follows:

$$Temperature\ (^{\circ}C) = 469.5 - (7.2 \times TEMP_READBACK)$$

READBACK MODE	READBACK VALUE															
	DB15	DB14	DB13	DB12	DB11	DB10	DB9	DB8	DB7	DB6	DB5	DB4	DB3	DB2	DB1	DB0
AFC READBACK	RV16	RV15	RV14	RV13	RV12	RV11	RV10	RV9	RV8	RV7	RV6	RV5	RV4	RV3	RV2	RV1
RSSI READBACK	X	X	X	X	X	LG2	LG1	FG2	FG1	RV7	RV6	RV5	RV4	RV3	RV2	RV1
BATTERY VOLTAGE/ADCIN/TEMP. SENSOR READBACK	X	X	X	X	X	X	X	X	X	RV7	RV6	RV5	RV4	RV3	RV2	RV1
SILICON REVISION	RV16	RV15	RV14	RV13	RV12	RV11	RV10	RV9	RV8	RV7	RV6	RV5	RV4	RV3	RV2	RV1
FILTER CAL READBACK	0	0	0	0	0	0	0	0	RV8	RV7	RV6	RV5	RV4	RV3	RV2	RV1

Figure 57. Readback Value Table

08635-1056

Silicon Revision Readback

The silicon revision readback word is valid without setting any other registers. The silicon revision word is coded with four quartets in BCD format. The product code (PC) is coded with three quartets extending from Bit RV16 to Bit RV5. The revision code (RC) is coded with one quartet extending from Bit RV4 to Bit RV1. The product code for the ADF7021-V reads back as PC = 0x212. The current revision code reads as RC = 0x0.

Filter Bandwidth Calibration Readback

The filter calibration readback word is contained in Bit RV8 to Bit RV1 (see Figure 57). This readback can be used for manual filter adjustment, thereby avoiding the need to do an IF filter calibration in some instances. The manual adjust value is programmed using Register 5, Bits[DB19:DB14]. To calculate the manual adjustment based on a filter calibration readback, use the following formula:

$$IF_FILTER_ADJUST = FILTER_CAL_READBACk - 128$$

Program the result into Register 5, Bits[DB19:DB14] as described in the Register 5—IF Filter Setup Register section.

INTERFACING TO A MICROCONTROLLER/DSP

Standard Transmit/Receive Data Interface

The standard transmit/receive signal and configuration interface to a microcontroller is shown in Figure 58. In transmit mode, the ADF7021-V provides the data clock on the TxRxCLK pin, and the TxRxDATA pin is used as the data input. The transmit data is clocked into the ADF7021-V on the rising edge of TxRxCLK.

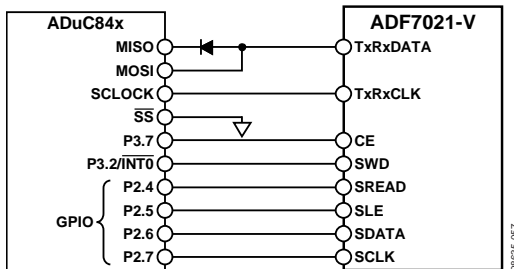

Figure 58. ADuC84x to ADF7021-V Connection Diagram

In receive mode, the ADF7021-V provides the synchronized data clock on the TxRxCLK pin. The received data is available on the TxRxDATA pin. Use the rising edge of TxRxCLK to clock the receive data into the microcontroller. See Figure 4 and Figure 5 for the relevant timing diagrams.

In 4FSK transmit mode, the MSB of the transmit symbol is clocked into the ADF7021-V on the first rising edge of the data clock from the TxRxCLK pin. In 4FSK receive mode, the MSB of the first payload symbol is clocked out on the first falling edge of the data clock after the SWD and can be clocked into the microcontroller on the following rising edge. See Figure 6 and Figure 7 for the relevant timing diagrams.

UART Mode

In UART mode, the TxRxCLK pin is configured to input transmit data in transmit mode. In receive mode, the receive data is available on the TxRxDATA pin, thus providing an asynchronous data interface. The UART mode can only be used with oversampled 2FSK modulation. Figure 59 shows a possible interface to a microcontroller using the UART mode of the ADF7021-V. To enable the UART interface mode, set Bit DB28 in Register 0 high. Figure 8 and Figure 9 show the relevant timing diagrams for UART mode.

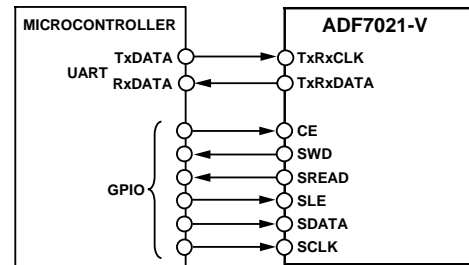

Figure 59. ADF7021-V (UART Mode) to Asynchronous Microcontroller Interface

SPI Mode

In SPI mode, the TxRxCLK pin is configured to input transmit data in transmit mode. In receive mode, the receive data is available on the TxRxDATA pin. The data clock in both transmit and receive modes is available on the CLKOUT pin. In transmit mode, data is clocked into the ADF7021-V on the rising edge of CLKOUT. In receive mode, the TxRxDATA data pin is sampled by the microcontroller on the rising edge of CLKOUT.

To enable SPI interface mode, set Bit DB28 in Register 0 high and set Bits[DB19:DB17] in Register 15 to 0x7. Figure 8 and Figure 9 show the relevant timing diagrams for SPI mode; Figure 60 shows the recommended interface to a microcontroller using the SPI mode of the ADF7021-V.

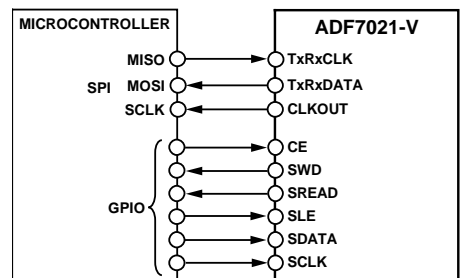

Figure 60. ADF7021-V (SPI Mode) to Microcontroller Interface

ADSP-BF533 Interface

The suggested method of interfacing to the Blackfin® ADSP-BF533 is shown in Figure 61.

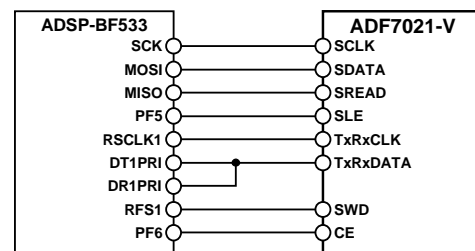

Figure 61. ADSP-BF533 to ADF7021-V Connection Diagram

REGISTER 0—N REGISTER

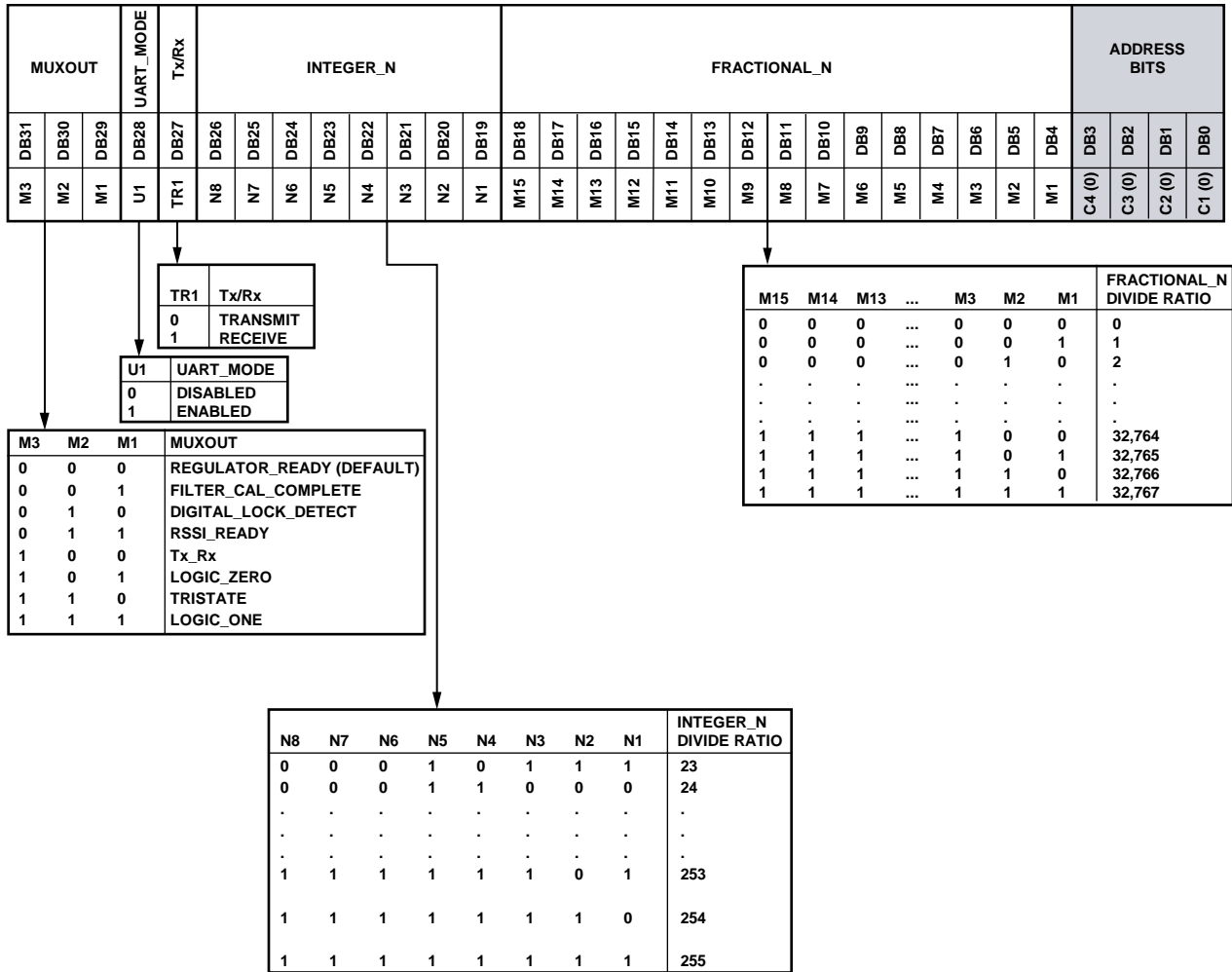

Figure 62. Register 0—N Register Map

018635-081

- The RF output frequency is calculated as follows:
For direct output,
$$RF_{OUT} = PFD \times \left(INTEGER_N + \frac{FRACTIONAL_N}{2^{15}} \right)$$

With RF_DIVIDE_BY_2 (Register 1, Bit DB18) enabled,
$$RF_{OUT} = PFD \times 0.5 \times \left(INTEGER_N + \frac{FRACTIONAL_N}{2^{15}} \right)$$
- In the MUXOUT map (Bits[DB31:DB29]), FILTER_CAL_COMPLETE indicates when a coarse or coarse plus fine IF filter calibration has finished. DIGITAL_LOCK_DETECT indicates when the PLL has locked. RSSI_READY indicates that the RSSI signal has settled and an RSSI readback can be performed. Tx_Rx gives the status of Bit DB27 in this register, which can be used to control an external Tx/Rx switch.
- In UART/SPI mode, the TxRxCLK pin is used to input the transmitted data. The received data is available on the TxRxDATA pin.

REGISTER 1—OSCILLATOR REGISTER

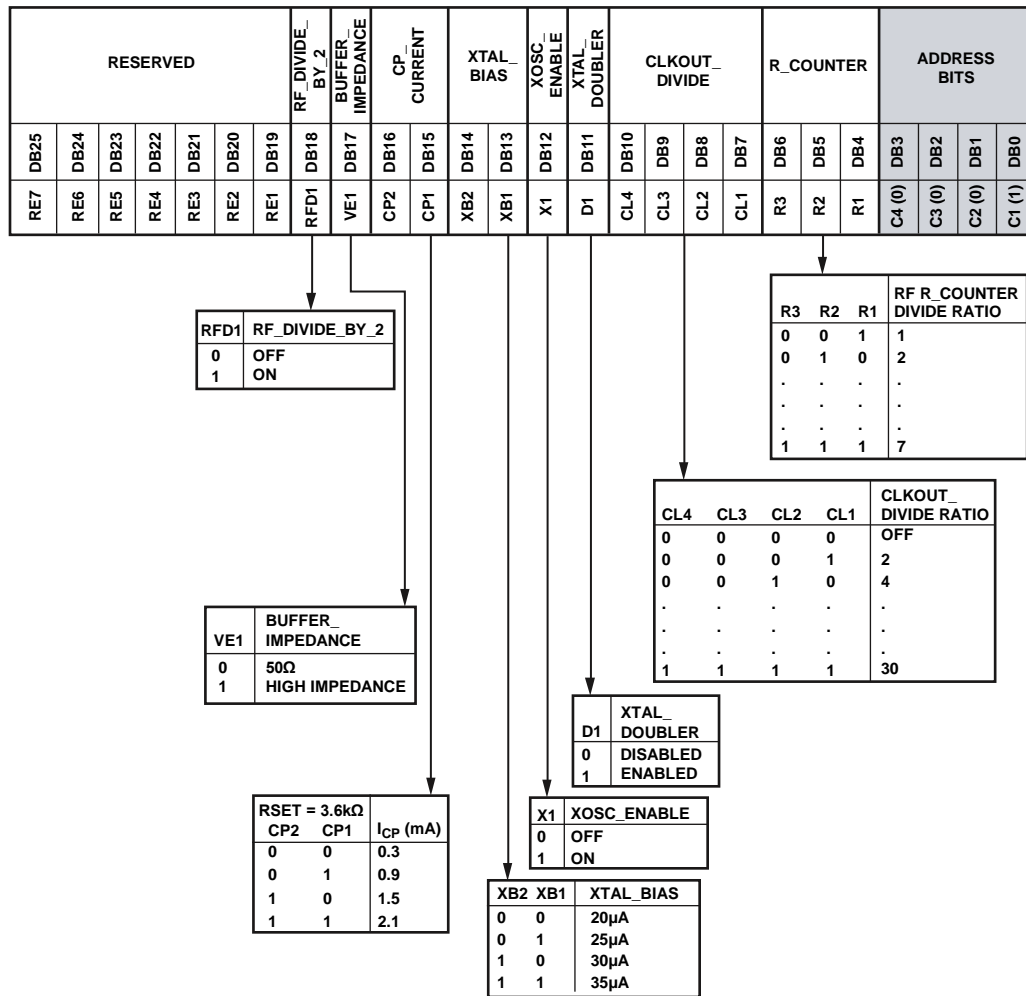

Figure 63. Register 1—Oscillator Register Map

08635-002

- The R_COUNTER and XTAL_DOUBLER relationship is as follows:

If XTAL_DOUBLER = 0,

$$PFD = \frac{XTAL}{R_COUNTER}$$

If XTAL_DOUBLER = 1,

$$PFD = \frac{XTAL \times 2}{R_COUNTER}$$

- CLKOUT_DIVIDE is a divided-down and inverted version of the XTAL and is available on Pin 36 (CLKOUT).
- Set XOSC_ENABLE high when using an external crystal. If using an external oscillator (such as TCXO) with CMOS level outputs into Pin OSC2, set XOSC_ENABLE low. If using an external oscillator with a 0.8 V p-p clipped sine wave output into Pin OSC1, set XOSC_ENABLE high.

REGISTER 2—TRANSMIT MODULATION REGISTER

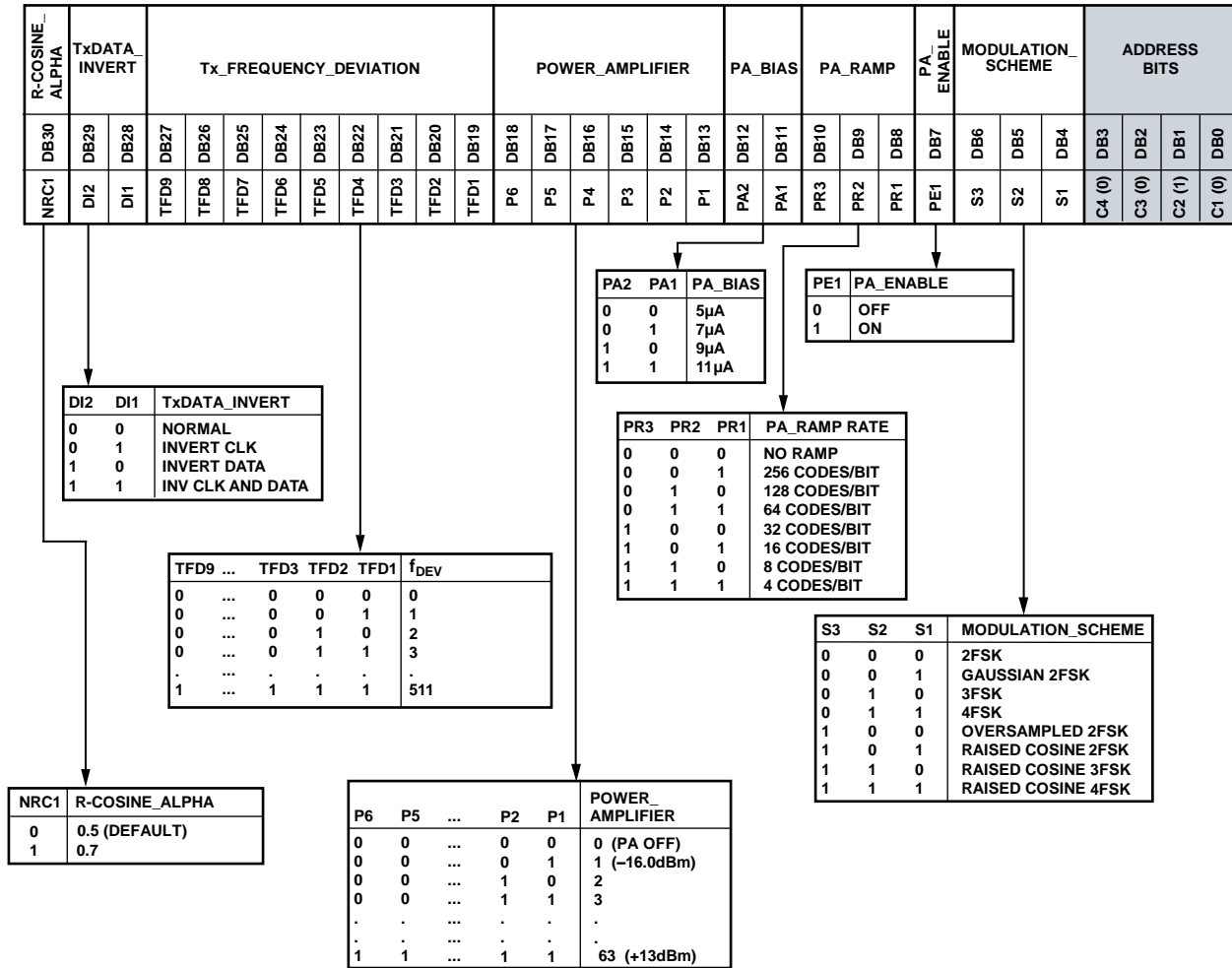

Figure 64. Register 2—Transmit Modulation Register Map

- The 2FSK/3FSK/4FSK frequency deviation is expressed as follows:

For direct RF output,

Frequency Deviation (Hz) =

$$\frac{T_x_FREQUENCY_DEVIATION \times PFD}{2^{16}}$$

With RF_DIVIDE_BY_2 (Register 1, Bit DB18) enabled,

Frequency Deviation (Hz) =

$$0.5 \times \frac{T_x_FREQUENCY_DEVIATION \times PFD}{2^{16}}$$

where:

T_x_FREQUENCY_DEVIATION is set by Bits[DB27:DB19].

PFD is the PFD frequency.

- In the case of 4FSK, there are tones at ±3 × the frequency deviation and at ±1 × the frequency deviation.

- The power amplifier (PA) ramps at the programmed rate (Bits[DB10:DB8]) until it reaches its programmed level (Bits[DB18:DB13]). If the PA is enabled/disabled by the PA_ENABLE bit (Bit DB7), it ramps up and down. If it is enabled/disabled by the Tx/Rx bit (Register 0, Bit DB27), it ramps up and turns hard off.
- R-COSINE_ALPHA sets the roll-off factor (alpha) of the raised cosine data filter to either 0.5 or 0.7. The alpha is set to 0.5 by default, but the raised cosine filter bandwidth can be increased to provide less aggressive data filtering by using an alpha of 0.7.

REGISTER 3—TRANSMIT/RECEIVE CLOCK REGISTER

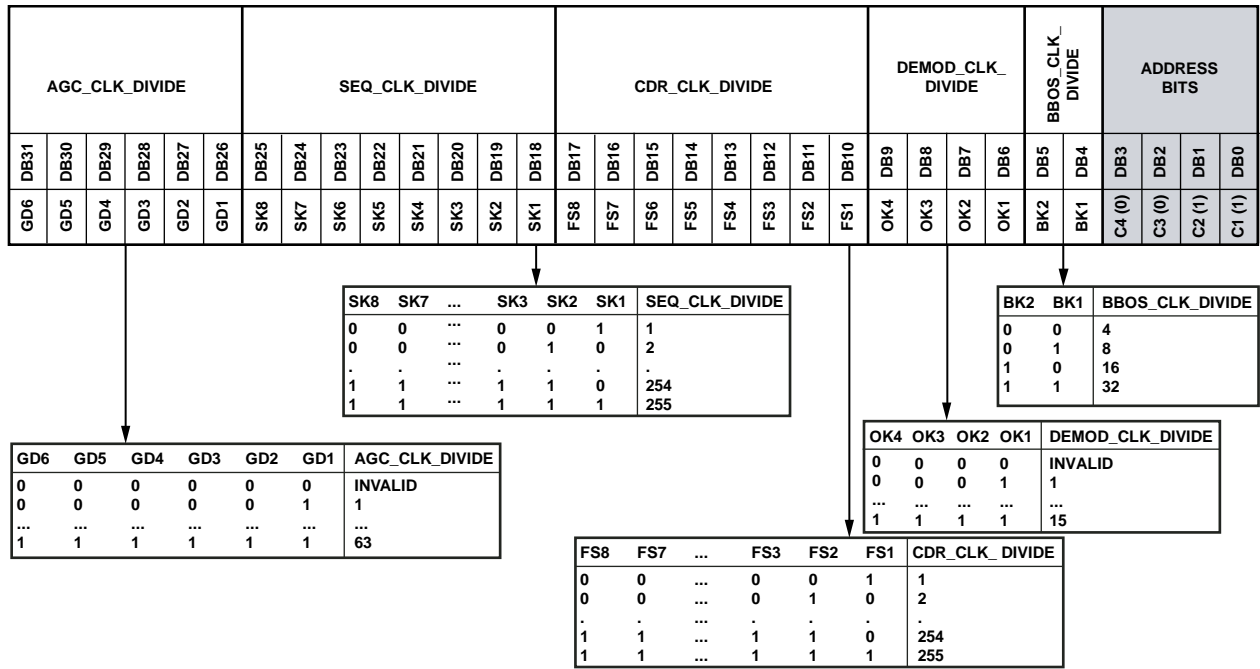

Figure 65. Register 3—Transmit/Receive Clock Register Map

08635-064

- Baseband offset clock frequency (BBOS CLK) must be greater than 1 MHz and less than 2 MHz, where
 $BBOS\ CLK = (XTAL / BBOS_CLK_DIVIDE)$
- Set the demodulator clock (DEMODO CLK) such that $2\text{ MHz} \leq DEMODO\ CLK \leq 15\text{ MHz}$, where
 $DEMODO\ CLK = (XTAL / DEMODO_CLK_DIVIDE)$
- For 2FSK/3FSK, the clock/data recovery frequency (CDR CLK) must be within 2% of $(32 \times \text{data rate})$. For 4FSK, the CDR CLK must be within 2% of $(32 \times \text{symbol rate})$.
 $CDR\ CLK = (DEMODO\ CLK / CDR_CLK_DIVIDE)$
- The sequencer clock (SEQ CLK) supplies the clock to the digital receive block. It is recommended to be as close to 100 kHz as possible.
 $SEQ\ CLK = (XTAL / SEQ_CLK_DIVIDE)$
- The time allowed for each AGC step to settle is determined by the AGC update rate. It is recommended to be set close to 3 kHz.
 $AGC\ Update\ Rate\ (Hz) = (SEQ\ CLK / AGC_CLK_DIVIDE)$

REGISTER 4—DEMODULATOR SETUP REGISTER

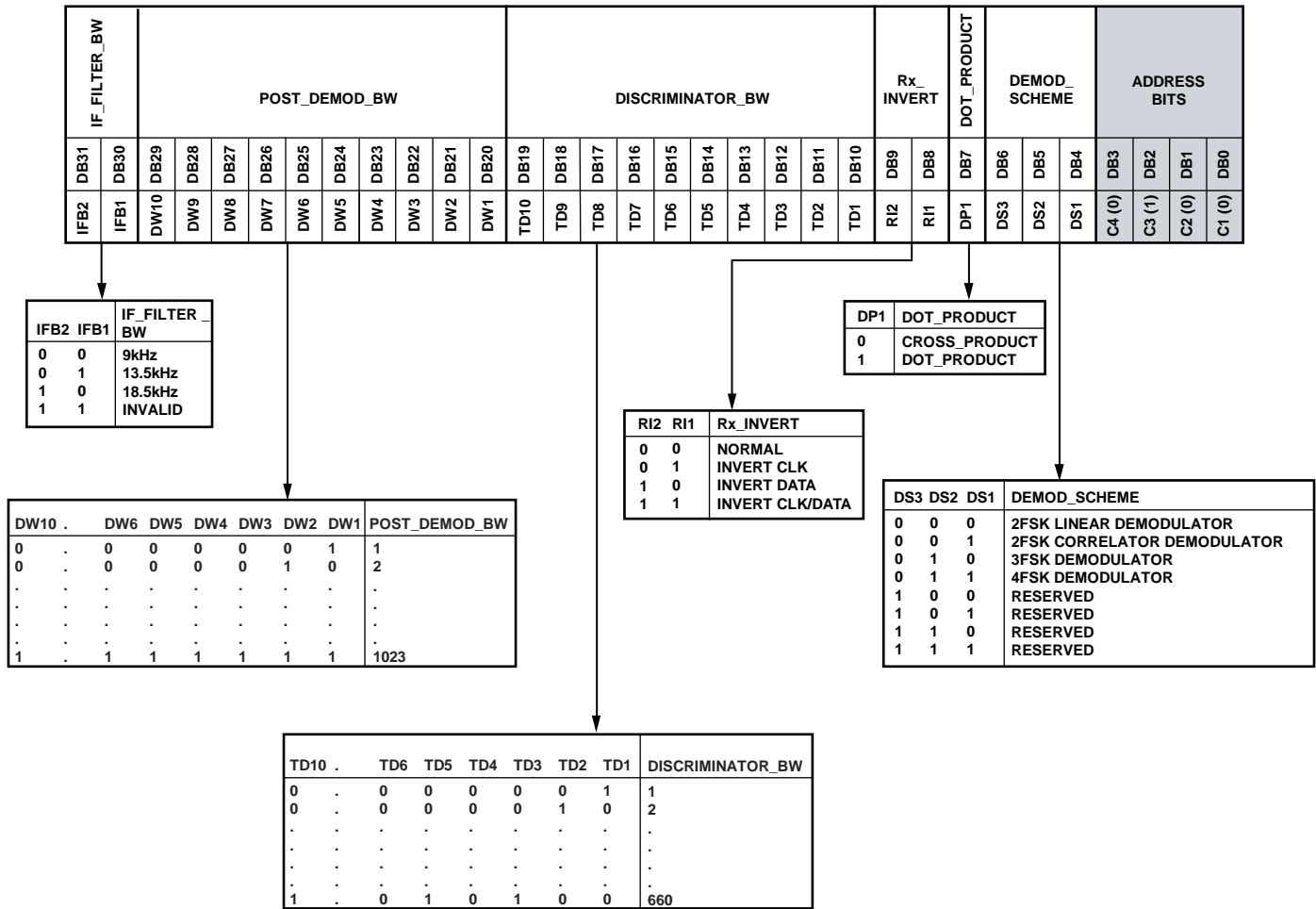

Figure 66. Register 4—Demodulator Setup Register Map

- To solve for DISCRIMINATOR_BW, (Bits[DB19:DB10]), use the following equation:

$$DISCRIMINATOR_BW = \left(\frac{DEMOMCLK \times K}{400 \times 10^3} \right)$$

where the maximum value = 660.

For 2FSK,

$$K = Round \left(\frac{100 \times 10^3}{f_{DEV}} \right)$$

For 3FSK,

$$K = Round \left(\frac{100 \times 10^3}{2 \times f_{DEV}} \right)$$

For 4FSK,

$$K = Round_{4FSK} \left(\frac{100 \times 10^3}{4 \times f_{DEV}} \right)$$

where:

Round is rounded to the nearest integer.

Round_{4FSK} is rounded to the nearest of the following integers:

32, 31, 28, 27, 24, 23, 20, 19, 16, 15, 12, 11, 8, 7, 4, 3.

f_{DEV} is the transmit frequency deviation in Hz. For 4FSK,

f_{DEV} is the frequency deviation used for the ±1 symbols (that is, the inner frequency deviations).

- Rx_INVERT (Bits[DB9:DB8]) and DOT_PRODUCT (Bit DB7) must be set as indicated in Table 16 and Table 17.
- POST_DEMOD_BW (Bits[DB29:DB20]) sets the bandwidth of the postdemodulator filter. To solve for POST_DEMOD_BW, use the following equation:

$$POST_DEMOD_BW = \frac{2^{11} \times \pi \times f_{CUTOFF}}{DEMOMCLK}$$

where f_{CUTOFF} (the cutoff frequency of the postdemodulator filter) is typically be set equal to 0.75 × the data rate in 2FSK. Round up POST_DEMOD_BW to the nearest integer value. In 3FSK, set it equal to the data rate. In 4FSK, set it equal to 1.6 × the symbol rate.

REGISTER 5—IF FILTER SETUP REGISTER

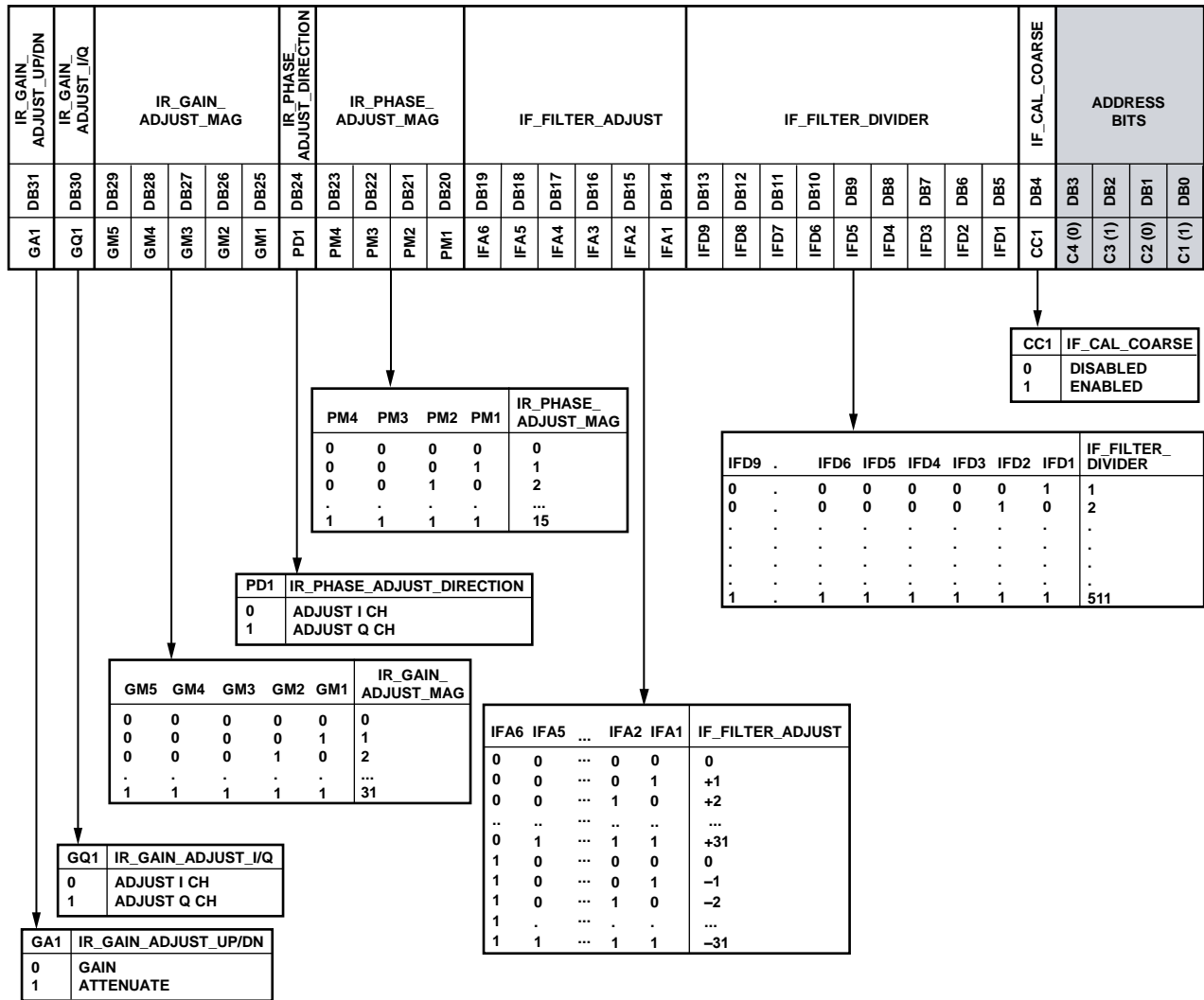

Figure 67. Register 5—IF Filter Setup Register Map

- A coarse IF filter calibration is performed when the IF_CAL_COARSE bit (Bit DB4) is set. If the IF_FINE_CAL bit (Register 6, Bit DB4) has been previously set, a fine IF filter calibration is automatically performed after the coarse calibration.
- Set IF_FILTER_DIVIDER such that

$$\frac{XTAL}{IF_FILTER_DIVIDER} = 50\text{kHz}$$

- IF_FILTER_ADJUST allows the IF fine filter calibration result to be programmed directly on subsequent receiver power-ups, thereby eliminating the need to redo a fine filter calibration in some instances. See the Filter Bandwidth Calibration Readback section for information about using the IF_FILTER_ADJUST bits.
- Bits[DB31:DB20] are used for image rejection calibration. See the Image Rejection Calibration section for information about how to program these parameters.

REGISTER 6—IF FINE CALIBRATION SETUP REGISTER

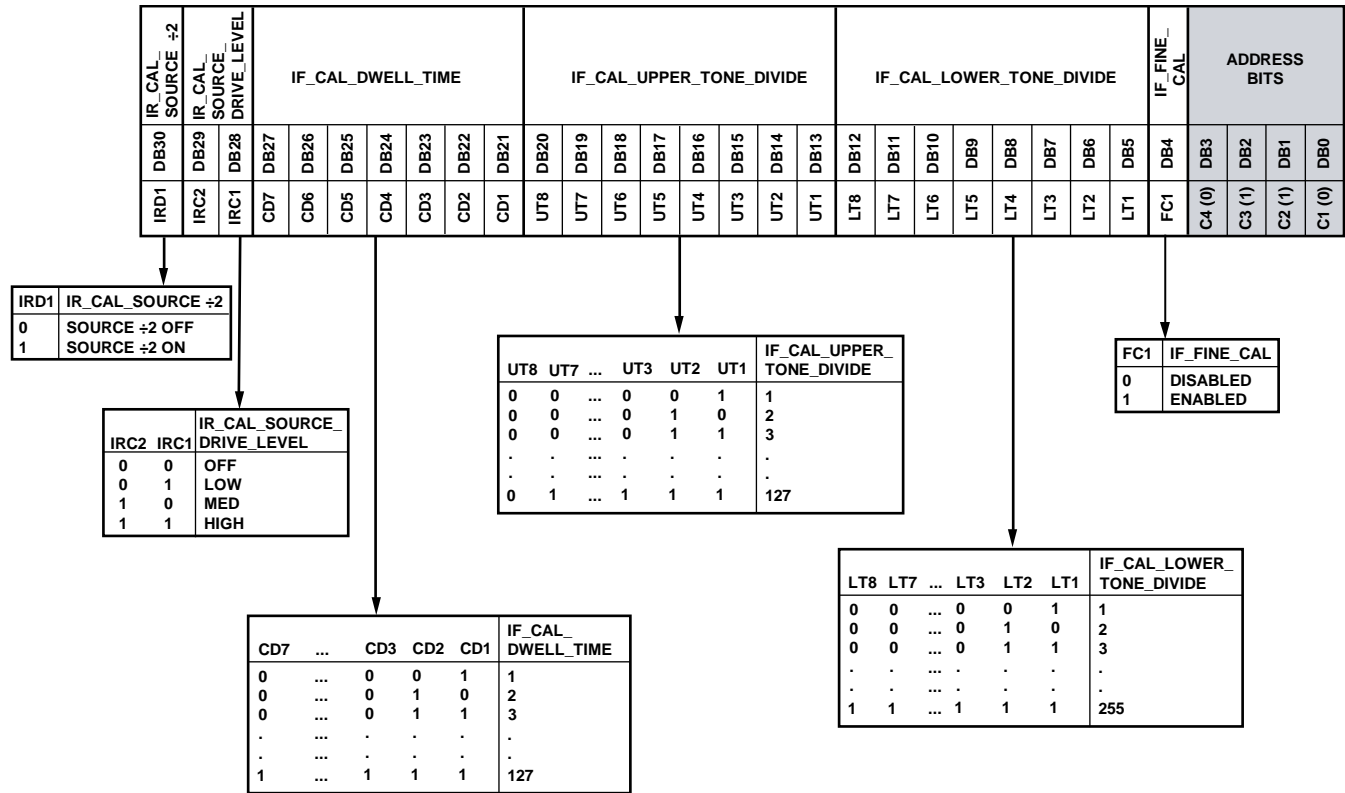

Figure 68. Register 6—IF Fine Calibration Setup Register Map

- A fine IF filter calibration is set by enabling the IF_FINE_CAL bit (Bit DB4). A fine calibration is performed only when Register 5 is written to and Register 5, Bit DB4 is set.
- Lower Tone Frequency (kHz) =

$$\frac{XTAL}{IF_CAL_LOWER_TONE_DIVIDE \times 2}$$

Upper Tone Frequency (kHz) =

$$\frac{XTAL}{IF_CAL_UPPER_TONE_DIVIDE \times 2}$$

It is recommended that the lower tone and the upper tone be set as shown in Table 24.

Table 24. IF Filter Fine Calibration Tone Frequencies

IF Filter Bandwidth (kHz)	Lower Tone Frequency (kHz)	Upper Tone Frequency (kHz)
9	78.1	116.3
13.5	79.4	116.3
18.5	78.1	119

- The IF tone calibration time is the amount of time that is spent at an IF calibration tone. It is dependent on the sequencer clock. It is recommended that the IF tone calibration time be at least 800 μs.

$$IF\ Tone\ Calibration\ Time = \frac{IF_CAL_DWELL_TIME}{SEQCLK}$$

The total time for a fine IF filter calibration is

$$IF\ Tone\ Calibration\ Time \times 10$$

- Bits[DB30:DB28] control the internal source for the image rejection (IR) calibration. The IR_CAL_SOURCE_DRIVE_LEVEL bits (Bits[DB29:DB28]) set the drive strength of the source, whereas the IR_CAL_SOURCE #2 bit (Bit DB30) allows the frequency of the internal signal source to be divided by 2.

08635-067

REGISTER 7—READBACK SETUP REGISTER

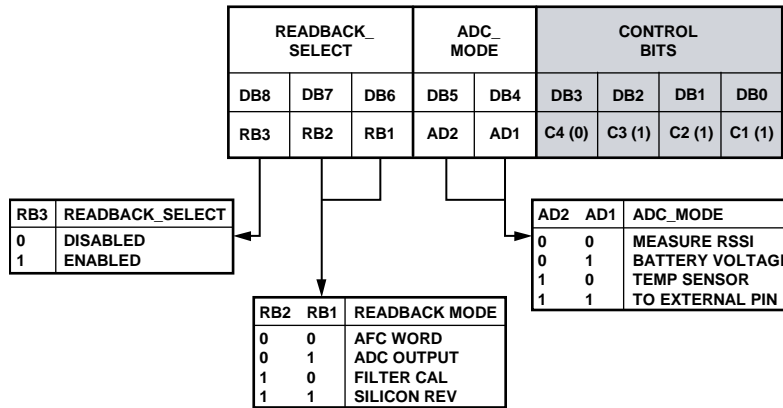

Figure 69. Register 7—Readback Setup Register Map

- Readback of the measured RSSI value is valid only in Rx mode. Readback of the battery voltage, temperature sensor, or voltage at the external ADCIN pin is not valid in Rx mode.
- To read back the battery voltage, the temperature sensor, or the voltage at the external ADCIN pin in Tx mode, first power up the ADC using Register 8, Bit DB8 because it is turned off by default in Tx mode to save power.

- For AFC readback, use the following equations (see the Readback Format section):

$$FREQ\ RB\ (Hz) = (AFC\ READBACK \times DEMOD\ CLK) / 2^{18}$$

$$V_{BATTERY} = BATTERY\ VOLTAGE\ READBACK / 21.1$$

$$V_{ADCIN} = ADCIN\ VOLTAGE\ READBACK / 42.1$$

$$Temperature\ (^{\circ}C) = 469.5 - (7.2 \times TEMP_READBACK)$$

REGISTER 8—POWER-DOWN TEST REGISTER

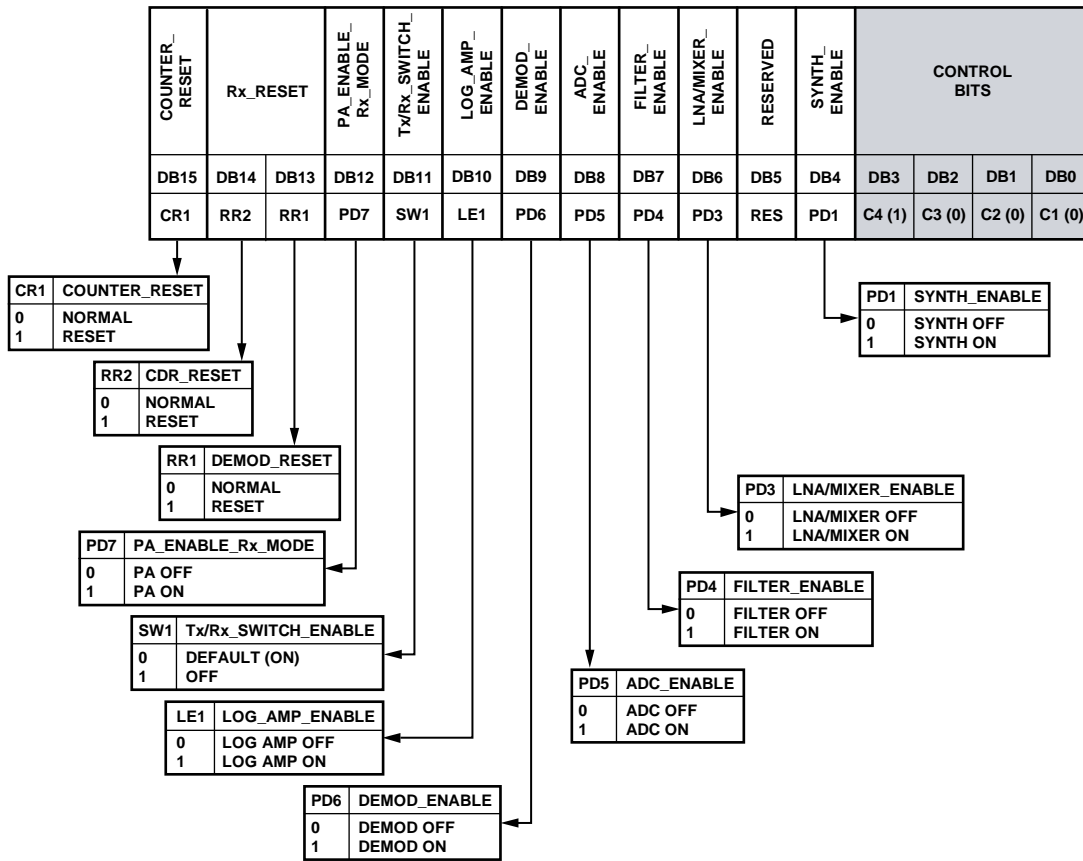

Figure 70. Register 8—Power-Down Test Register Map

It is not necessary to write to this register under normal operating conditions.

For a combined LNA/PA matching network, always set Bit DB11 to 0, which enables the internal Tx/Rx switch. This is the power-up default condition.

REGISTER 9—AGC REGISTER

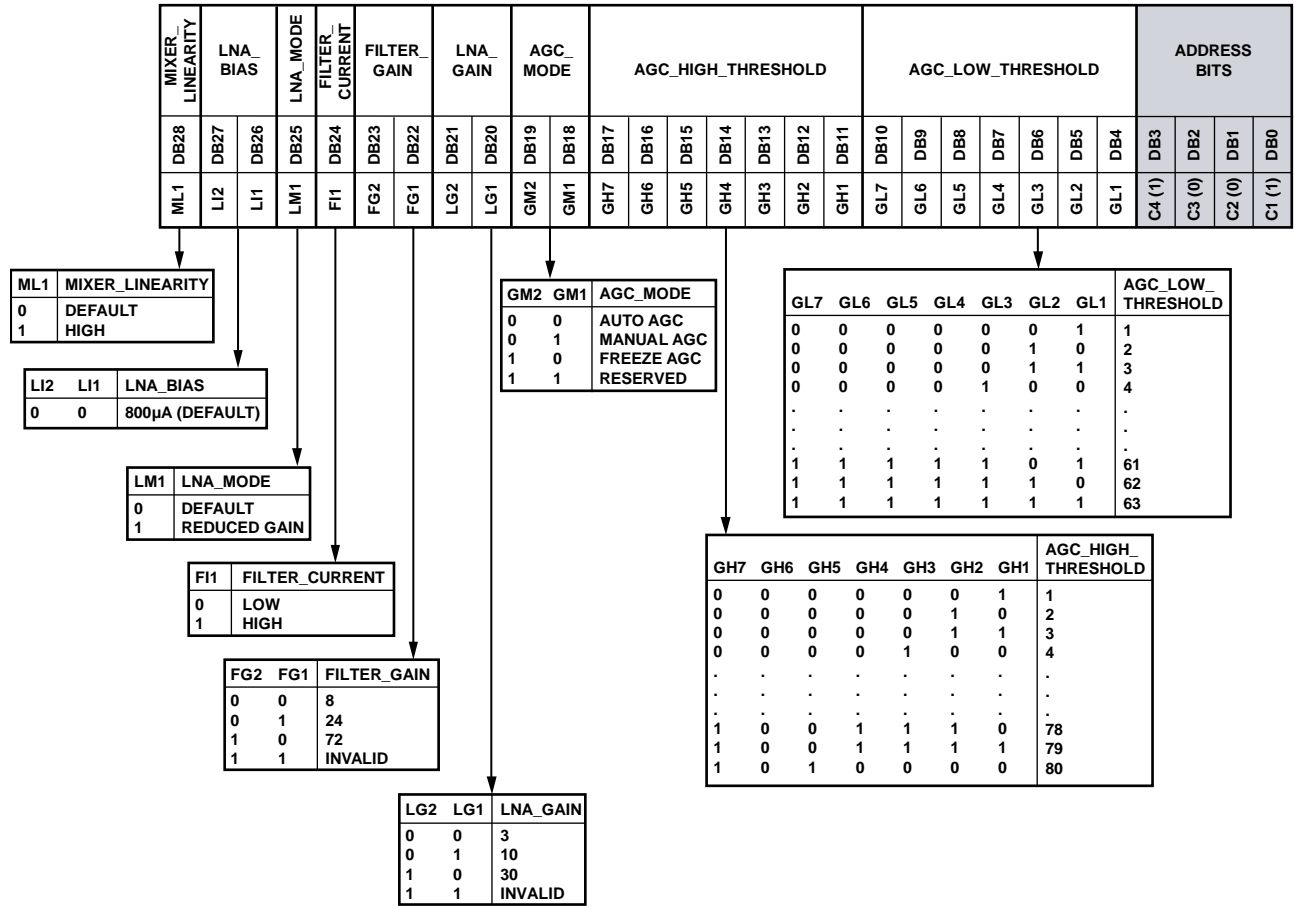

Figure 71. Register 9—AGC Register Map

08635-070

- It is necessary to program this register only if AGC settings other than the defaults are required.
- In receive mode, AGC is set to automatic AGC by default on power-up. The default thresholds are AGC_LOW_THRESHOLD = 30 and AGC_HIGH_THRESHOLD = 70. See the RSSI/AGC section for details.
- AGC high and low threshold values must be more than 30 apart to ensure correct operation.
- An LNA gain of 30 is available only if LNA_MODE (Bit DB25) is set to 0.

REGISTER 10—AFC REGISTER

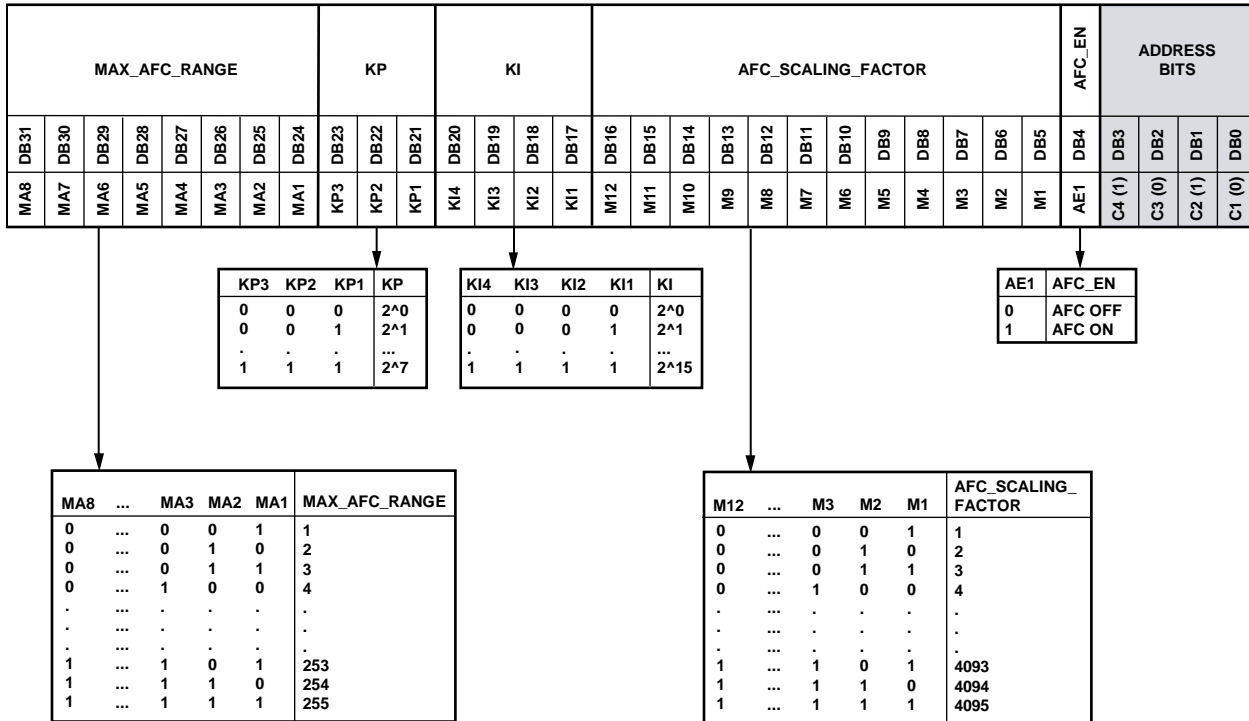

Figure 72. Register 10—AFC Register Map

08635-071

- The AFC_SCALING_FACTOR can be expressed as
- The settings for KI and KP affect the AFC settling time and AFC accuracy. The allowable range for each parameter is KI > 6 and KP < 7.
- The recommended settings for optimal AFC performance are KI = 11 and KP = 4. To trade off between AFC settling time and AFC accuracy, the KI and KP parameters can be adjusted from the recommended settings (staying within the allowable range) such that

$$AFC\ Correction\ Range = MAX_AFC_RANGE \times 500\ Hz$$

- When RF_DIVIDE_BY_2 (Register 1, Bit DB18) is enabled, the programmed AFC correction range is halved. The user must account for this halving by doubling the programmed MAX_AFC_RANGE value. For example, for a desired correction range of ±5 kHz, with RF_DIVIDE_BY_2 enabled, set MAX_AFC_RANGE (R10_DB[24:31]) equal to 20.
- Signals that are within the AFC pull-in range but outside the IF filter bandwidth are attenuated by the IF filter. As a result, the signal can be below the sensitivity point of the receiver and, therefore, not detectable by the AFC.

REGISTER 11—SYNC WORD DETECT REGISTER

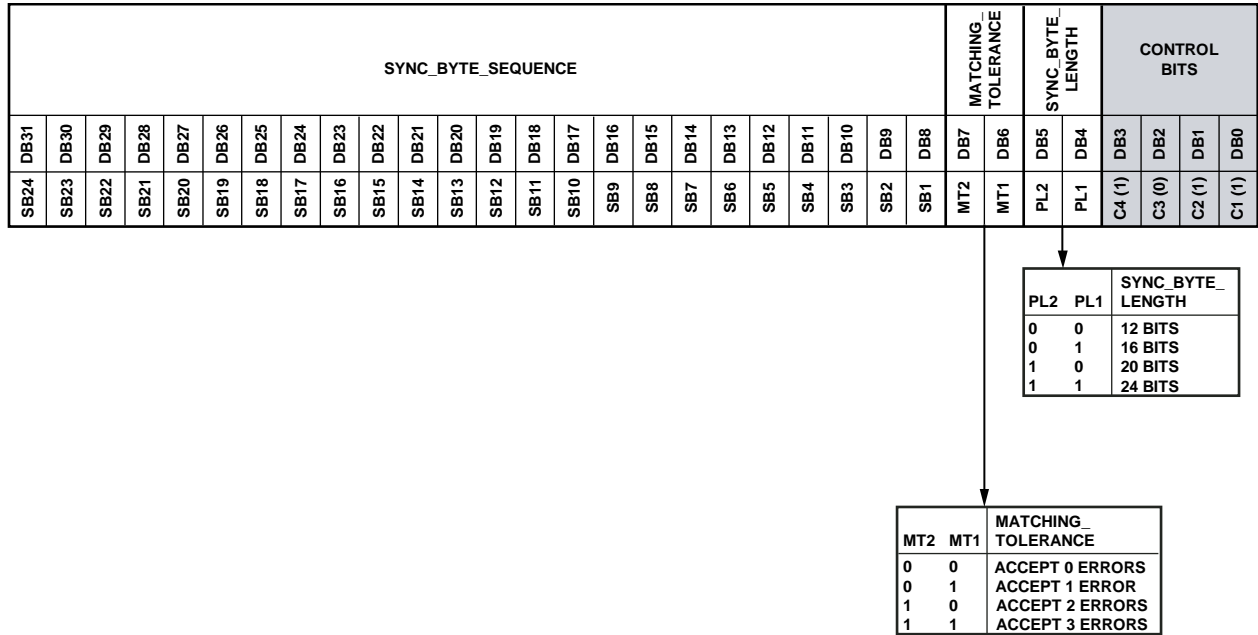

Figure 73. Register 11—Sync Word Detect Register Map

08635-072

REGISTER 12—SWD/THRESHOLD SETUP REGISTER

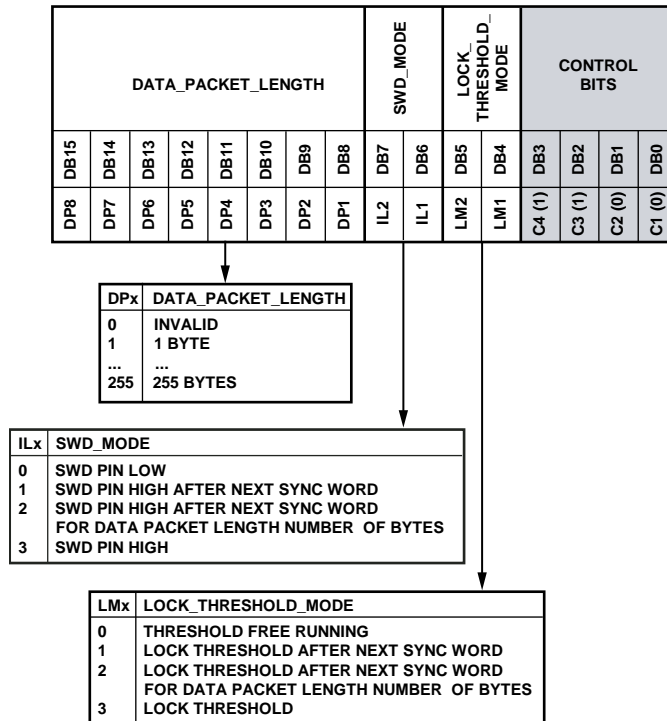

Figure 74. Register 12—SWD/Threshold Setup Register Map

08635-073

Lock threshold locks the threshold of the envelope detector. This has the effect of locking the slicer in linear demodulation

and locking the AFC and AGC loops when using linear or correlator demodulation.

REGISTER 13—3FSK/4FSK DEMODULATION REGISTER

See the Receiver Setup section for information about programming these settings.

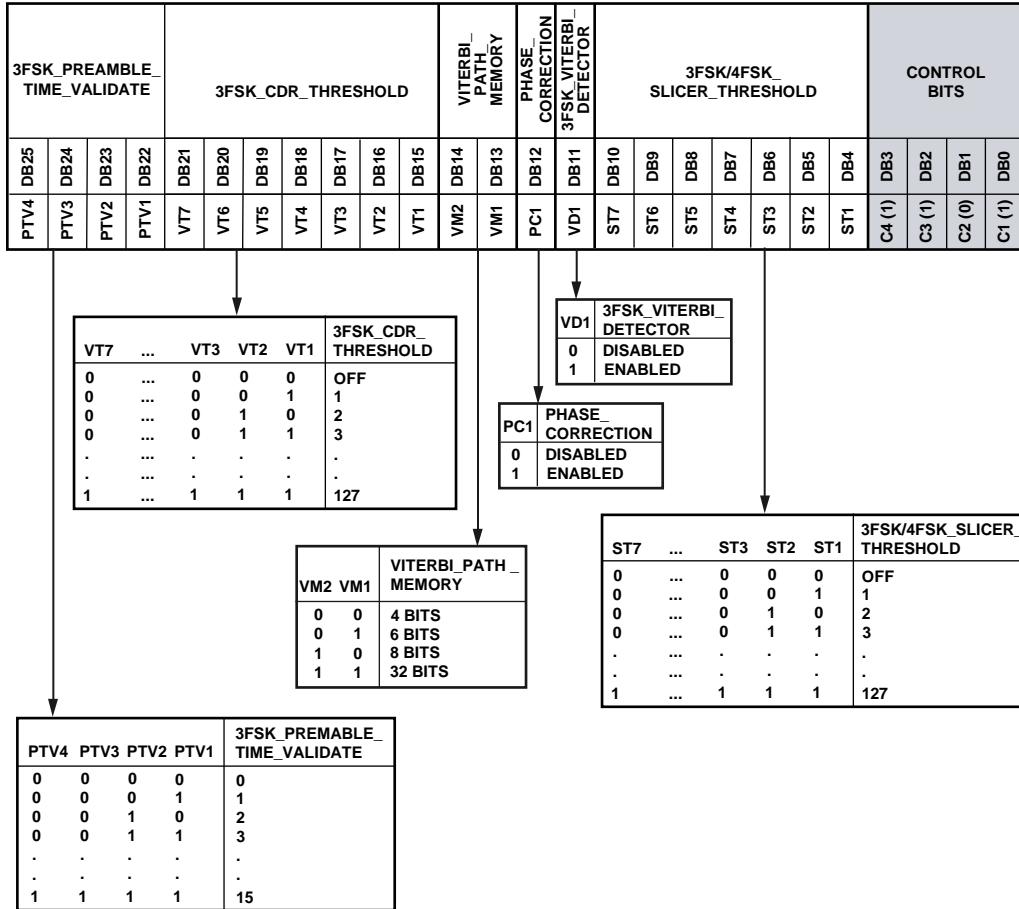

Figure 75. Register 13—3FSK/4FSK Demodulation Register Map

08635-074

REGISTER 14—TEST DAC REGISTER

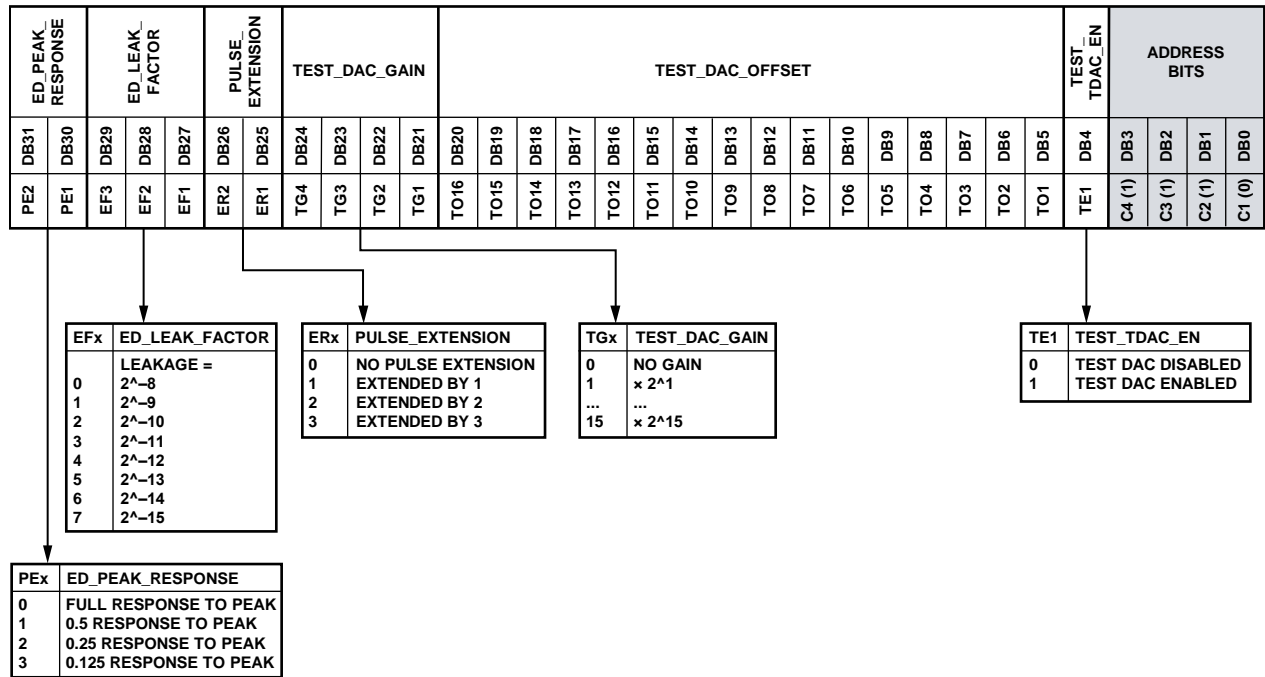

Figure 76. Register 14—Test DAC Register Map

08635-075

The demodulator tuning parameters, PULSE_EXTENSION, ED_LEAK_FACTOR, and ED_PEAK_RESPONSE, can be enabled only by setting Register 15, Bits[DB7:DB4] to 0x9.

Using the On-Chip Test DAC

The on-chip test DAC can be used to implement analog demodulation or to provide access for measurement of FSK demodulator output SNR or CNR. For detailed information about using the test DAC, see the AN-852 Application Note.

The test DAC allows the postdemodulator filter output for both linear and correlator demodulators to be viewed externally. The test DAC also takes the 16-bit filter output and converts it to a high frequency, single-bit output using a second-order, error feedback Σ-Δ converter. The output can be viewed on the SWD pin. This signal, when filtered appropriately, can then be used to do the following:

- Monitor the signals at the FSK postdemodulator filter output. This allows the demodulator output SNR to be measured. Eye diagrams of the received bit stream can also be constructed to measure the received signal quality.
- Provide analog FM demodulation.

Whereas the correlators and filters are clocked by DEMOD CLK, the test DAC is clocked by CDR CLK. Note that although the test DAC functions in regular user mode, the best performance is achieved when CDR CLK is increased to or above the frequency of DEMOD CLK. The CDR block does not function when this condition exists.

Programming Register 14 enables the test DAC. Both the linear and correlator demodulator outputs can be multiplexed into the DAC.

Register 14 allows a fixed offset term to be removed from the signal (to remove the IF component in the linear demodulator case). It also has a signal gain term to allow the usage of the maximum dynamic range of the DAC.

REGISTER 15—TEST MODE REGISTER

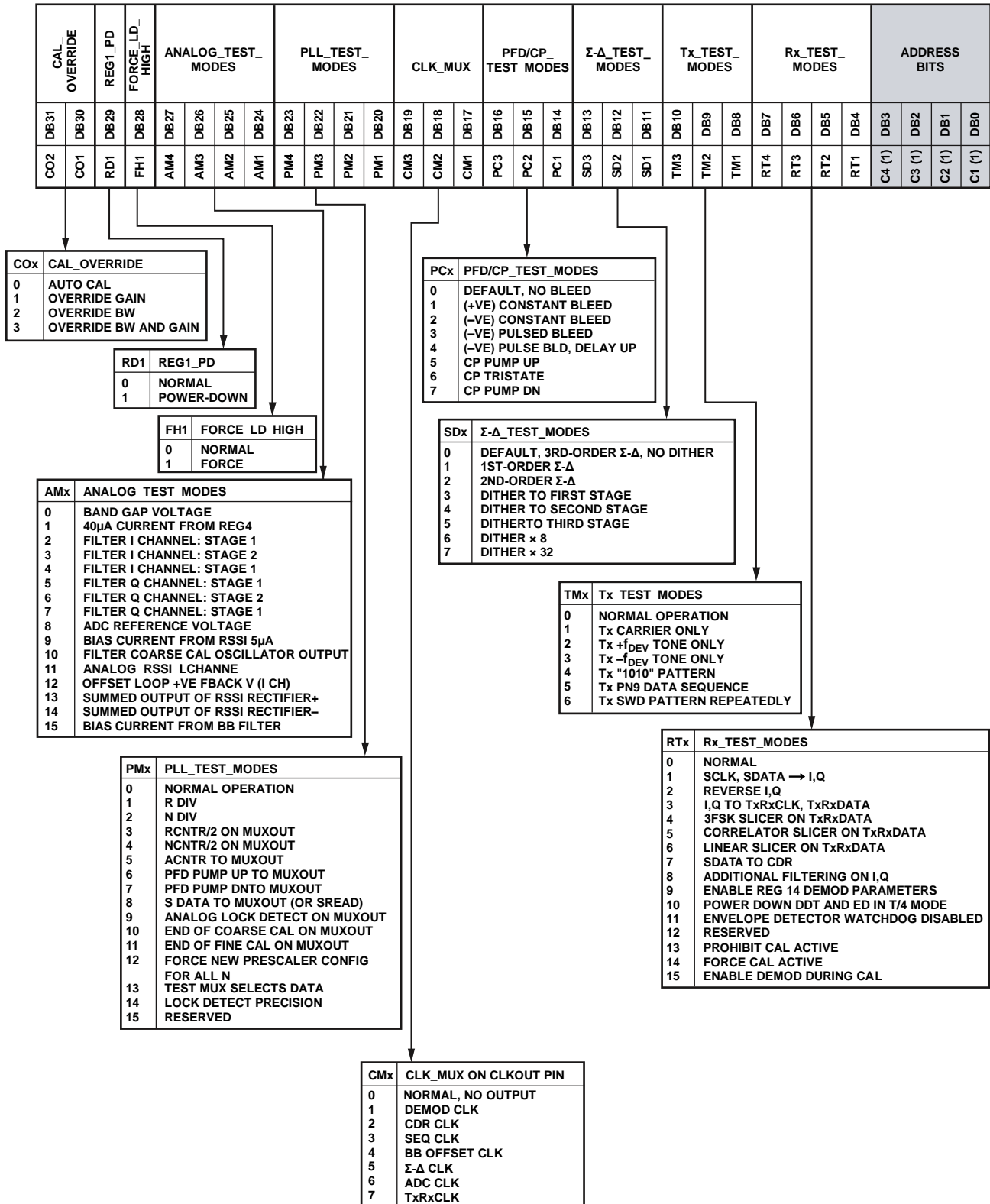
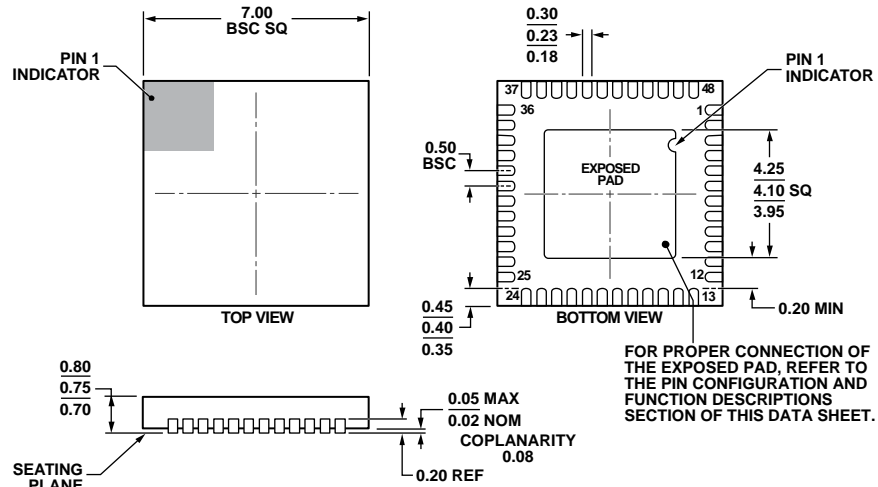

Figure 77. Register 15—Test Mode Register Map

- Analog RSSI can be viewed on the TEST_A pin by setting ANALOG_TEST_MODES (Bits[DB27:DB24]) to 11.
- Tx_TEST_MODES can be used to enable modulation test.
- The CDR block can be bypassed by setting Rx_TEST_MODES to 4, 5, or 6, depending on the demodulator used.

OUTLINE DIMENSIONS



COMPLIANT TO JEDEC STANDARDS MO-220-WKKD.

Figure 78. 48-Lead Lead Frame Chip Scale Package [LFCSP_WQ]
 7 mm × 7 mm Body, VeryVery Thin Quad
 (CP-48-5)

Dimensions shown in millimeters

08-16-2010-B

ORDERING GUIDE

Model ^{1,2}	Temperature Range	Package Description	Package Option
ADF7021-VBCPZ	-40°C to +85°C	48-Lead Lead Frame Chip Scale Package [LFCSP_WQ]	CP-48-5
ADF7021-VBCPZ-RL	-40°C to +85°C	48-Lead Lead Frame Chip Scale Package [LFCSP_WQ]	CP-48-5
EVAL-ADF70XXMBZ2		Evaluation Platform Mother Board	
EVAL-ADF7021-VDB1Z		450 MHz to 470 MHz Daughter Board	
EVAL-ADF7021-VDB2Z		868 MHz to 870 MHz Daughter Board	
EVAL-ADF7021-VDB3Z		156 MHz to 162 MHz Daughter Board	

¹ Z = RoHS Compliant Part.

² CP-48-5 package formerly CP-48-3.

Looking for pricing, stock, or lifecycle information?

Click below to explore more details on WIN SOURCE:

 [View ADF7021-VBCPZ-RL on WIN SOURCE](#)

 [Analog Devices Inc. Information](#)

Optimize Your Supply Chain with WIN SOURCE Solutions

-  Global Sourcing Solution
-  Obsolete Management
-  Cost Control Management
-  Shortage Management
-  Alternative Solution
-  Excess Inventory Management