

MC56F80XXX

MC56F80xxx

Supports MC56F807xx and
MC56F806xx

Features

- This family of digital signal controllers (DSCs) is based on the 32-bit 56800EF core. On a single chip, each device combines the processing power of a DSP and the functionality of an MCU, with a flexible set of peripherals to support many target applications:
 - Industrial control
 - Motion control
 - Home appliances
 - General-purpose inverters
 - Smart sensors, fire and security systems
 - Switched-mode power supply and power management
 - Uninterruptible power supplies (UPS)
 - Solar inverter
 - Medical monitoring applications
- DSC based on 32-bit 56800EF core
 - Up to 100 MIPS at 100 MHz core frequency
 - DSP and MCU functionality in a unified, C-efficient architecture
 - Enhanced single-precision Floating Point math Unit (eFPU)
 - COordinate Rotation DIgital Compute (CORDIC) engine
- On-chip memory
 - Up to 64 KB flash memory
 - 8 KB data/program RAM
 - Both on-chip flash memory and RAM can be mapped into both program and data memory spaces
- Analog
 - Two high-speed, 12-bit ADCs with dynamic x1, x2, and x4 programmable amplifier
 - Up to two operational amplifiers, programmable gain up to x16
 - Three analog comparators with integrated 8-bit DAC references
 - On-chip temperature sensors
- One high-resolution eFlexPWM module, with up to 12 PWM outputs, including up to 8 channels with 312ps resolution NanoEdge placement
- Communication interfaces
 - Up to two high-speed queued SCI (QSCI) modules with LIN slave functionality
 - One queued SPI (QSPI) module
 - One LPI2C module (supports Full PMBus)
- Timers
 - One 16-bit quad timer (1 x 4Ch)
 - Up to three 32-bit Periodic Interval Timers (PITs)
 - One enhanced Quadrature Decoder (eQDC)
- Security and integrity
 - Cyclic Redundancy Check (CRC) generator
 - Windowed Computer operating properly (COP) watchdog
 - External Watchdog Monitor (EWM)
- Clocks
 - On-chip oscillators: 200 kHz, and 8/2MHz IRC
 - Crystal / resonator oscillator
- System
 - 4-channel enhanced DMA controller, supporting up to 63 request sources
 - Integrated power-on reset (POR) and low-voltage interrupt (LVI) and brown-out reset module
 - Inter-Module Crossbar and Event Generator
 - JTAG/enhanced on-chip emulation (EOnCE) for unobtrusive, real-time debugging
- Operating characteristics
 - Single supply: 2.7 V to 3.6 V
 - Operation ambient temperature (V grade temperature): -40°C to 105°C
 - Operation ambient temperature (M grade temperature): -40°C to 125°C
- 64-pin LQFP, 48-pin LQFP packages (32-pin LQFP and QFN optional)

Table of Contents

1	Overview.....	3	7.8	Definition: Typical value.....	35
1.1	Product Family.....	3	7.9	Typical value conditions.....	36
1.2	56800EF 32-bit Digital Signal Controller (DSC) core.....	4	8	Ratings.....	37
1.3	Operation Parameters.....	5	8.1	Thermal handling ratings.....	37
1.4	Interrupt Controller.....	5	8.2	Moisture handling ratings.....	37
1.5	Peripheral highlights.....	6	8.3	ESD and latch-up ratings.....	37
1.6	System Block Diagram.....	13	8.4	Voltage and current operating ratings.....	38
2	Signal and pin descriptions.....	15	9	General.....	38
3	Signal groups.....	25	9.1	General characteristics.....	38
4	Pinout.....	25	9.2	AC electrical characteristics.....	39
4.1	Signal Multiplexing and Pin Assignments.....	25	9.3	Nonswitching electrical specifications.....	39
4.2	Pinout diagrams.....	27	9.4	Switching specifications.....	45
5	Ordering parts.....	30	9.5	Thermal specifications.....	46
5.1	Determining valid orderable parts.....	30	10	Peripheral operating requirements and behaviors.....	47
5.2	Part number list.....	30	10.1	Core modules.....	47
6	Part identification.....	31	10.2	System modules.....	48
6.1	Description.....	31	10.3	Clock modules.....	49
6.2	Format.....	31	10.4	Memories and memory interfaces.....	51
6.3	Fields.....	31	10.5	Analog.....	53
6.4	Example.....	32	10.6	PWMs and timers.....	58
7	Terminology and guidelines.....	32	10.7	Communication interfaces.....	59
7.1	Definition: Operating requirement.....	32	11	Design Considerations.....	64
7.2	Definition: Operating behavior.....	33	11.1	Thermal design considerations.....	64
7.3	Definition: Attribute.....	33	11.2	Electrical design considerations.....	66
7.4	Definition: Rating.....	33	11.3	Power-on Reset design considerations.....	67
7.5	Result of exceeding a rating.....	34	12	Obtaining package dimensions.....	68
7.6	Relationship between ratings and operating requirements.....	34	13	Revision history.....	69
7.7	Guidelines for ratings and operating requirements.....	35			

1 Overview

1.1 Product Family

Table 1. MC56F80xxx Family

Feature	MC56F80														
	748	738	746	736	726	743	733	723	648	646	626	643	623		
Core frequency (MHz)	100														
Flash memory (KB)	64	48	64	48	32	64	48	32	64	64	32	64	32		
RAM (KB)	8	8	8	8	6	8	8	6	8	8	6	8	6		
Inter Module Xbar	Yes														
Event Generator	4														
Windowed Watchdog	1														
External Watchdog Monitor	1														
eDMA	4CH														
Internal OSC	8 MHz / 200 KHz														
External Crystal Oscillator	Yes (4 MHz ~ 16 MHz)														
Comparator + 8-bit DAC	3														
Operational Amplifier	2					1			2			1			
12-bit Cyclic ADC channels	2 × 14-ch														
High-resolution PWM	8-ch		6-ch ¹					—							
Standard PWM	4-ch		2-ch			—			8-ch		6-ch ¹		6-ch ¹		
Input Capture in PWM pin															
QTimers	4 × 16-bit														
Enhanced Quadrature Decoder	1								—						
Periodic Interval Timers	3 × 32-bit								2 × 32-bit						
LPI2C (supports Full PMBus)	1														
QSCI	2					1			2			1			
QSPI	1														
GPIO	54		39			26			54		39		26		
Operating Temperature	-40°C to 105°C (V grade temperature)					-40°C to 105°C (V grade temperature)									
	-40°C to 125°C (M grade temperature)														
Package	64 LQFP		48 LQFP			32 LQFP/QFN ²			64 LQFP		48 LQFP		32 LQFP ²		

1. Only include the PWM channels with output pins. All internal 8 channels PWM are available through the on-chip inter-module crossbar.

2. The 32 LQFP and 32 QFN packages for this product are not yet available. However, the pin-out and pricing information of these packages are readily available. These devices are then committed for sampling and production based on customer demand.

1.2 56800EF 32-bit Digital Signal Controller (DSC) core

- 100 MHz CPU frequency
- Efficient 32-bit 56800EF Digital Signal Processor (DSP) engine with modified dual Harvard architecture:
 - Three internal address buses
 - Four internal data buses: two 32-bit primary buses, one 16-bit secondary data bus, and one 16-bit instruction bus
 - 32-bit data accesses
 - Supports concurrent instruction fetches in the same cycle, and dual data accesses in the same cycle
 - 20 addressing modes
- Enhanced single-precision Floating Point math Unit (eFPU):
 - Supports floating-point instruction acceleration based on the *IEEE 754-2008* standard
 - Beside normal operations (add, subtract, multiply and divide), it also supports operations such as: min, max, square root, as well as a rich set of data format conversions
- COordinate Rotation DIgital Compute (CORDIC) engine:
 - Uses 32-bit fixed-point signed fractional numbers in *Q5.27* format
 - Trigonometric Math:
 - Supports calculations of selected trigonometric, inverse trig, hyperbolic and exponentiation functions using circular and hyperbolic coordinates in both rotation and vector modes
 - Calculates trigonometric and hyperbolic functions using simple, small iterative hardware structure
- Instruction set supports both fractional arithmetic and integer arithmetic
- 32-bit internal primary data buses support 8-bit, 16-bit, and 32-bit data movement, plus addition, subtraction, and logical operations
- Single-cycle 16×16 -bit \rightarrow 32-bit and 32×32 -bit \rightarrow 64-bit multiplier-accumulator (MAC) with dual parallel moves
- 32-bit arithmetic and logic multi-bit shifter
- Fast integer and fraction 32/16 and 32/32 divide instructions
- Four 36-bit accumulators, including extension bits
- Parallel instruction set with unique DSP addressing modes
- Hardware DO and REP loops
- Bit reverse address mode, which effectively supports DSP and Fast Fourier Transform algorithms

- Full shadowing of the register stack for zero-overhead context saves and restores: nine shadow registers correspond to nine address registers (R0, R1, R2, R3, R4, R5, N, N3, M01)
- Instruction set supports both DSP and controller functions
- Controller-style addressing modes and instructions enable compact code
- Enhanced bit manipulation instruction set
- Efficient C compiler and local variable support
- Software subroutine and interrupt stack, with the stack's depth limited only by memory
- Priority level setting for interrupt levels
- JTAG/Enhanced On-Chip Emulation (EOnCE) for unobtrusive, real-time debugging that is independent of processor speed

1.3 Operation Parameters

- Operation ambient temperature:
 - V grade temperature: -40 °C to 105°C
 - M grade temperature: -40 °C to 125°C
- Single power supply
 - Supply range: $V_{DD} - V_{SS} = 2.7 \text{ V to } 3.6 \text{ V}$, $V_{DDA} - V_{SSA} = 2.7 \text{ V to } 3.6 \text{ V}$

1.4 Interrupt Controller

- Five interrupt priority levels
 - Three user-programmable priority levels for each interrupt source: level 0, level 1, level 2
 - Unmaskable level 3 interrupts include illegal instruction, hardware stack overflow, misaligned data access, SWI3 instruction
 - Interrupt level 3 is highest priority and non-maskable. Its sources include:
 - Illegal instructions
 - Hardware stack overflow
 - SWI instruction
 - EOnCE interrupts
 - Misaligned data accesses
 - Lowest-priority software interrupt: level LP
- Support for nested interrupts, so that a higher priority level interrupt request can interrupt lower priority interrupt subroutine
- Masking of interrupt priority level is managed by the 56800EF core
- Two programmable fast interrupts that can be assigned to any interrupt source

- Notification to System Integration Module (SIM) to restart clock when in wait and stop states
- Ability to relocate interrupt vector table

1.5 Peripheral highlights

1.5.1 Enhanced Flex Pulse Width Modulator (eFlexPWM)

- 16 bits of resolution for center, edge-aligned, and asymmetrical PWMs
- 6 bit addition for high resolution PWM
 - Fractional delay for enhanced resolution of the PWM period and edge placement
 - Arbitrary PWM edge placement
 - 312 ps PWM frequency and duty-cycle and deadtime resolution when NanoEdge functionality is enabled.
- PWM outputs can be configured as complementary output pairs or independent outputs
- Dedicated time-base counter with period and frequency control per submodule
- Independent top and bottom deadtime insertion for each complementary pair
- Independent control of both edges of each PWM output
- Enhanced input capture and output compare functionality on each input:
 - Channels not used for PWM generation can be used for buffered output compare functions.
 - Channels not used for PWM generation can be used for input capture functions.
 - Enhanced dual edge capture functionality
- Synchronization of submodule to external hardware (or other PWM) is supported.
- Double-buffered PWM registers
 - Integral reload rates from 1 to 16
 - Half-cycle reload capability
- Multiple output trigger events can be generated per PWM cycle via hardware.
- Support for double-switching PWM outputs
- Up to eight fault inputs can be assigned to control multiple PWM outputs
 - Programmable filters for fault inputs
- Independently programmable PWM output polarity
- Individual software control of each PWM output
- All outputs can be programmed to change simultaneously via a FORCE_OUT event.
- PWMX pin can optionally output a third PWM signal from each submodule
- Option to supply the source for each complementary PWM signal pair from any of the following:

- Crossbar module outputs
- External ADC input, taking into account values set in ADC high and low limit registers
- Direct phase shift controls among each submodule
- Trigger signal can share the same load frequency as reload signal in each submodule

1.5.2 12-bit Analog-to-Digital Converter (Cyclic type)

- Two independent 12-bit analog-to-digital converters (ADCs):
 - 2 x 14-channel external inputs
 - Built-in x1, x2, x4 programmable gain pre-amplifier
 - Maximum ADC clock frequency up to 12.5 MHz, having period as low as 80 ns
 - Single conversion time of 10 ADC clock cycles
 - Additional conversion time of 8 ADC clock cycles
- Support of analog inputs for single-ended and differential (including unipolar differential) conversions
- Sequential and parallel scan modes. Parallel mode includes simultaneous and independent scan modes.
- Samples of each ADC have offset, limit and zero-crossing calculation supported
- ADC conversions can be synchronized by *any* module connected to the internal crossbar module, such as PWM, timer, GPIO, and comparator modules.
- Support for hardware-triggering and software-triggering conversions
- Support for a multi-triggering mode with a programmable number of conversions on each trigger
- Each ADC has ability to scan and store up to 10 conversion results.
- Current injection protection

1.5.3 Operational Amplifier (OPAMP)

- Capability of being configured as various types of amplifier:
 - standalone operational amplifier
 - unity gain follower (voltage follower)
 - x2, x4, x8, x16 programmable gain amplifier (PGA)
 - differential amplifier
 - low-pass filter
- 4-to-1 input multiplexer on inverting and non-inverting input
- 4 set configurations including multiplexer inputs can be managed by internal modules and synchronized with ADCs, PWMs and timers
- Operation modes: high speed mode and low power mode

1.5.4 Comparator

- Full rail-to-rail comparison range
- Support for high and low speed modes
- Selectable input source includes external pins and internal DACs
- Programmable output polarity
- 8-bit programmable DAC as a voltage reference per comparator
- Three programmable hysteresis levels
- Selectable interrupt on rising-edge, falling-edge, or toggle of a comparator output

1.5.5 Periodic Interrupt Timer (PIT)

- 32-bit counter with programmable count modulo
- PIT0/1 can be master and PIT2 is slave mode only (if synchronizing with other PITs)
- The output signals of both PIT0 and PIT1 are internally connected to a peripheral crossbar module
- Can run when the CPU is in Wait/Stop modes. Can also wake up the CPU from Wait/Stop modes.
- In addition to System Bus Clock (IPBus Clock), alternate clock sources for the counter clock are also available:
 - Crystal oscillator output
 - 8 MHz / 2 MHz internal RC output
 - On-chip low-power 200 kHz oscillator

1.5.6 Quadrature Decoder (QDC)

- Includes logic to decode quadrature signals
- Inputs can be connected to a general purpose timer to make low speed velocity measurements
- Configurable digital filter for inputs
- Quadrature decoder filter can be bypassed
- 32-bit position counter capable of modulo counting
- Position counter can be initialized by software or external events
- 16-bit position difference register
- Compare function can indicate when shaft has reached a defined position
- A watchdog timer can detect a non-rotating shaft condition
- Preloadable 16-bit revolution counter
- Maximum count frequency equals the peripheral clock rate
- Optional interrupt when both PHASEA and PHASEB inputs change in the same cycle

1.5.7 Inter-Module Crossbar and Event Generator (EVTG) logic

- Provides generalized connections between and among on-chip peripherals: ADCs, comparators, quad-timers, eFlexPWMs, EWM, quadrature decoder, and select I/O pins
- User-defined input/output pins for all modules connected to the crossbar
- DMA request and interrupt generation from the crossbar
- Write-once protection for all registers
- The EVTG module mainly includes two parts: Two AND/OR/INVERT (known simply as the AOI) modules and one configurable Flip-Flop. It supports the generation of a configurable number of EVENT signals. The inputs are from crossbar (XBAR) outputs, and the outputs feed to XBAR inputs.

1.5.8 Quad Timer

- Four 16-bit up/down counters, with a programmable prescaler for each counter
- Operation modes: edge count, gated count, signed count, capture, compare, PWM, signal shot, single pulse, pulse string, cascaded, quadrature decode
- Programmable input filter
- Counting start can be synchronized across counters

1.5.9 Queued Serial Communications Interface (QSCI) modules with LIN Slave Functionality

- Operating clock can be up to two times the CPU operating frequency
- Four-word-deep FIFOs available on both transmit and receive buffers
- Standard mark/space non-return-to-zero (NRZ) format
- 16-bit integer and 3-bit fractional baud rate selection
- Full-duplex or single-wire operation
- Programmable 8-bit or 9-bit data format
- Error detection capability
- Two receiver wakeup methods:
 - Idle line
 - Address mark
- 1/16 bit-time noise detection
- Support for Local Interconnect Network (LIN) slave operation

1.5.10 Queued Serial Peripheral Interface (QSPI) modules

- Maximum 25 Mbit/s baud rate

- Selectable baud rate clock sources for low baud rate communication
- Baud rate as low as the maximum Baud rate / 4096
- Full-duplex operation
- Master and slave modes
- Double-buffered operation with separate transmit and receive registers
- Four-word-deep FIFOs available on transmit and receive buffers
- Programmable length transmissions (2 bits to 16 bits)
- Programmable transmit and receive shift order (MSB or LSB as first bit transmitted)

1.5.11 Low Power Inter-Integrated Circuit (LPI2C)

The LPI2C supports:

- Standard, Fast, Fast+ and Ultra Fast modes are supported
- High speed mode (HS) in slave mode
- High speed mode (HS) in master mode, if SCL pin implements current source pull-up (device-specific)
- Multi-master support, including synchronization and arbitration. Multi-master means any number of master nodes can be present. Additionally, master and slave roles may be changed between messages (after a STOP is sent).
- Clock stretching: Sometimes multiple I2C nodes may be driving the lines at the same time. If any I2C node is driving a line low, then that line will be low. I2C nodes that are starting to transmit a logical one (by letting the line float high) can detect that the line is low, and thereby know that another I2C node is active at the same time.
 - When node detection is used on the SCL line, it is called *clock stretching*, and clock stretching is used as a I2C flow control mechanism for multiple slaves.
 - When node detection is used on the SDA line, it is called *arbitration*, and arbitration ensures that there is only one I2C node transmitter at a time.
- General call, 7-bit and 10-bit addressing
- Software reset, START byte and Device ID (also require software support)

The LPI2C master supports:

- Command/transmit FIFO of 4words.
- Receive FIFO of 4words.
- Command FIFO will wait for idle I2C bus before initiating transfer
- Command FIFO can initiate (repeated) START and STOP conditions and one or more master-receiver transfers
- STOP condition can be generated from command FIFO, or generated automatically when the transmit FIFO is empty
- Host request input to control the start time of an I2C bus transfer

- Flexible receive data match can generate interrupt on data match and/or discard unwanted data
- Flag and optional interrupt to signal Repeated START condition, STOP condition, loss of arbitration, unexpected NACK, and command word errors
- Supports configurable bus idle timeout and pin-stuck-low timeout

The I2C slave supports:

- Separate I2C slave registers to minimize software overhead because of master/slave switching
- Support for 7-bit or 10-bit addressing, address range, SMBus alert and general call address
- Transmit data register that supports interrupt or DMA requests
- Receive data register that supports interrupt or DMA requests
- Software-controllable ACK or NACK, with optional clock stretching on ACK/NACK bit
- Configurable clock stretching, to avoid transmit FIFO underrun and receive FIFO overrun errors
- Flag and optional interrupt at end of packet, STOP condition, or bit error detection

1.5.12 Windowed Computer Operating Properly (COP) watchdog

- Programmable windowed timeout period
- Support for operation in all power modes: run mode, wait mode, stop mode
- Causes loss of reference reset 128 cycles after loss of reference clock to the PLL is detected
- Selectable reference clock source in support of EN60730 and IEC61508
- Selectable clock sources:
 - External crystal oscillator
 - On-chip low-power 200 kHz oscillator
 - System bus clock (IPBus clock)
 - 8 MHz / 2 MHz IRC
- Support for interrupt generation

1.5.13 External Watchdog Monitor (EWM)

- Monitors external circuit as well as the software flow
- Programmable timeout period
- Interrupt capability prior to timeout
- Independent output (EWM_OUT_b) that places external circuit (but not CPU and peripheral) in a safe mode when EWM timeout occurs

- Selectable reference clock source in support of EN60730 and IEC61508
- Wait mode and Stop mode operation is not supported.
- Selectable clock sources:
 - External crystal oscillator
 - On-chip low-power 200 kHz oscillator
 - System bus clock (IPBus clock)
 - 8 MHz / 2 MHz IRC

1.5.14 Power supervisor (PMC)

- Power-on reset (POR) is released after VDD is greater than the Low-Voltage Warning threshold during supply is ramped up; CPU, peripherals, and JTAG/EOnCE controllers exit RESET state
- Brownout reset ($V_{DD} < 2.0$ V)
- Critical low-voltage alarm interrupt (LVI_2p2)
- Peripheral low-voltage warning interrupt (LVI_2p65)

1.5.15 Phase-locked loop

- Output frequency range is optimized from 200 MHz to 550 MHz
- Input reference clock frequency: 8 MHz to 16 MHz
- Detection of loss of lock and loss of reference clock
- Ability to power down

1.5.16 Clock sources

1.5.16.1 On-chip oscillators

- Tunable 8 MHz RC oscillator with 2 MHz at standby mode
- 200 kHz low frequency clock as secondary clock source for COP, EWM, PIT

1.5.16.2 Crystal oscillator

- Support for both high ESR crystal oscillator (ESR greater than 100 Ω) and ceramic resonator
- Operating frequency: 4–16 MHz

1.5.17 Cyclic Redundancy Check (CRC) generator

- Hardware 16/32-bit CRC generator
- High-speed hardware CRC calculation

- Programmable initial seed value
- Programmable 16/32-bit polynomial
- Error detection for all single, double, odd, and most multi-bit errors
- Option to transpose input data or output data (CRC result) bitwise or bytewise,¹ which is required for certain CRC standards
- Option for inversion of final CRC result

1.5.18 General Purpose I/O (GPIO)

- Individual control of peripheral mode or GPIO mode for each pin
- Programmable push-pull or open drain output
- Configurable pullup or pulldown on all input pins
- All pins (except JTAG, RESET_B) default to be GPIO inputs
- Controllable output slew rate

1.6 System Block Diagram

NOTE

The following figure shows the maximum memory configurations supported.

1. A bytewise transposition is not possible when accessing the CRC data register via 8-bit accesses. In this case, user software must perform the bytewise transposition.

Clock sources

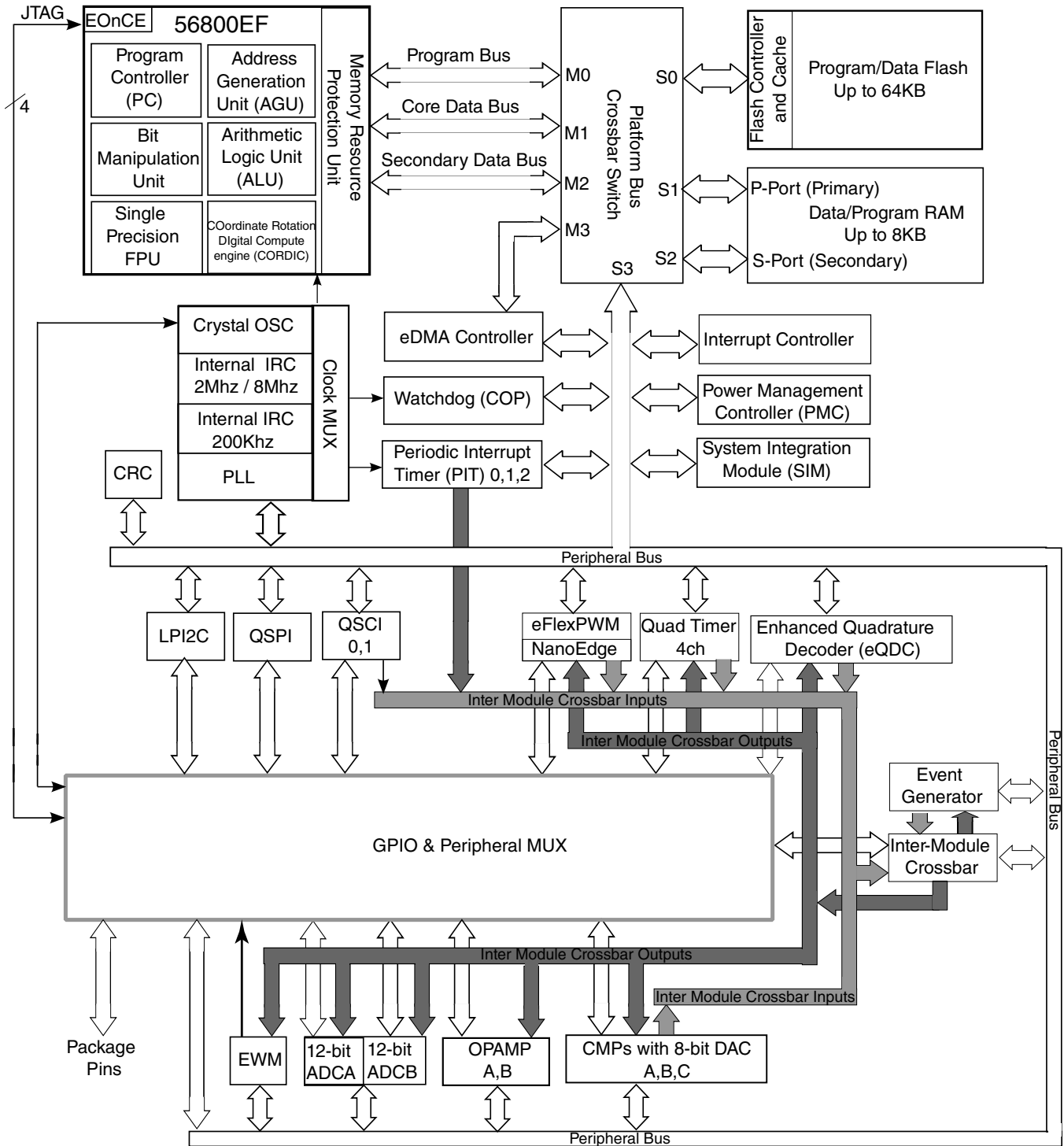

Figure 1. System block diagram

2 Signal and pin descriptions

After reset, each pin is configured for its primary function (listed first). Any alternative functionality, shown in parentheses, must be programmed through the GPIO module peripheral enable registers (GPIOx_PER) and the SIM module GPIO peripheral select (GPSx) registers. All GPIO ports can be individually programmed as an input or output (using bit manipulation).

For the MC56F80xxx products, which use 64-pin LQFP, 48-pin LQFP and 32-pin LQFP packages:

Table 2. Signal descriptions

Signal Name	64 LQFP	48 LQFP	32 LQFP/QFN	State During Reset	Type	Signal Description
V _{DD}	29	—	—	Supply	Supply	I/O Power — Supplies 3.3 V power to the chip I/O interface.
	44	32	—			
	60	44	28			
V _{SS}	30	22	14	Supply	Supply	I/O Ground — Provide ground for the device I/O interface.
	43	31	—			
	61	45	29			
V _{DDA}	22	15	9	Supply	Supply	Analog Power — Supplies 3.3 V power to the analog modules. It must be connected to a clean analog power supply.
V _{SSA}	23	16	10	Supply	Supply	Analog Ground — Supplies an analog ground to the analog modules. It must be connected to a clean power supply.
V _{CAP}	26	19	—	On-chip regulator output	On-chip regulator output	Connect a 2.2 μ F or greater bypass capacitor between this pin and V _{SS} to stabilize the core voltage regulator output required for proper device operation. NOTE: The total bypass capacitor value between all V _{CAP} pins and V _{SS} recommends between 4.0 μ F ~ 5.0 μ F.
	57	43	27			
TDI	64	48	32	Input, internal pullup enabled	Input	Test Data Input — Provides a serial input data stream to the JTAG/EOnCE port. It is sampled on the rising edge of TCK and has an internal pullup resistor. After reset, the default state is TDI.
(GPIOD0)					Input/Output	GPIO Port D0.
TDO	62	46	30	Output	Output	Test Data Output — This tri-state-able pin provides a serial output data stream from the JTAG/EOnCE port. It is driven in the shift-IR and shift-DR controller states, and it changes on the falling edge of TCK. After reset, the default state is TDO.
(GPIOD1)					Input/Output	GPIO Port D1.

Table continues on the next page...

Table 2. Signal descriptions (continued)

Signal Name	64 LQFP	48 LQFP	32 LQFP/QFN	State During Reset	Type	Signal Description
TCK	1	1	1	Input, internal pulldown enabled	Input	Test Clock Input — This input pin provides a gated clock to synchronize the test logic and shift serial data to the JTAG/EOnCE port. The pin is connected internally to a pulldown resistor. A Schmitt-trigger input is used for noise immunity. After reset, the default state is TCK.
(GPIOD2)					Input/Output	GPIO Port D2.
TMS	63	47	31	Input, internal pullup enabled	Input	Test Mode Select Input — Used to sequence the JTAG TAP controller state machine. It is sampled on the rising edge of TCK and has an internal pullup resistor. After reset, the default state is TMS. NOTE: Always tie the TMS pin to V _{DD} through a 2.2 kΩ resistor if need to keep on-board debug capability. Otherwise, directly tie to V _{DD} . Except being configured as GPIO.
(GPIOD3)					Input/Output	GPIO Port D3.
RESET_B	2	2	2	Input, internal pullup enabled	Input	Reset — A direct hardware reset on the processor. When RESET_B is asserted low, the device is initialized and placed in the reset state. A Schmitt-trigger input is used for noise immunity. The internal reset signal is deasserted synchronously with the internal clocks after a fixed number of internal clocks. After reset, the default state is RESET_B. Recommended a capacitor of 0.1 μF for filtering noise and up to 22 μF for time delay if required.
(GPIOD4)					Input/Open-drain Output	GPIO Port D4 — Can be individually programmed as an input or open-drain output pin. RESET_B functionality is disabled in this mode and the device can be reset only through Power-On Reset (POR), COP reset, or software reset.
GPIOA0	13	9	6	Input	Input/Output	GPIO Port A0 — After reset, the default state is GPIOA0.
(ANA0 & CMPA_IN3 & OPAMPA_IN3)					Input	ANA0 — ADCA channel 0 input. CMPA_IN3 — Analog comparator A input 3 OPAMPA_IN3 — Operational amplifier A input 3 When used as an analog input, the signal goes to ANA0 and CMPA_IN3 and OPAMPA_IN3. ¹
(CMPC_O)					Output	Analog comparator C output.
GPIOA1	14	10	7	Input	Input/Output	GPIO Port A1 — After reset, the default state is GPIOA1.
(ANA1 & CMPA_IN0)					Input	ANA1 — ADCA channel 1 input. CMPA_IN0 — Analog comparator A input 0. OPAMPA_IN0 — Operational amplifier A input 0.

Table continues on the next page...

Table 2. Signal descriptions (continued)

Signal Name	64 LQFP	48 LQFP	32 LQFP/QFN	State During Reset	Type	Signal Description
& OPAMPA_IN0)						When used as an analog input, the signal goes to ANA1 and CMPA_IN0 and OPAMPA_IN0. ¹
GPIOA2	15	11	8	Input	Input/ Output	GPIO Port A2 — After reset, the default state is GPIOA2.
(ANA2 & VREFHA & CMPA_IN1)					Input	ANA2 — ADCA channel 2 input. VREFHA — ADCA analog reference high. CMPA_IN1 — Analog comparator A input 1. When used as an analog input, the signal goes to ANA2 (or VREFHA) and CMPA_IN1. ¹ NOTE: ADC input can be configured as either ANA2 or VREFHA in the ADC Calibration Register.
GPIOA3	16	12	—	Input	Input/ Output	GPIO Port A3 — After reset, the default state is GPIOA3.
(ANA3 & VREFLA & CMPA_IN2)					Input	ANA3 — ADCA channel 3 input. VREFLA — ADCA analog reference low. CMPA_IN2 — Analog comparator A input 2. When used as an analog input, the signal goes to ANA3 (or VREFLA) and CMPA_IN2. ¹ NOTE: ADC input can be configured as either ANA3 or VREFLA in the ADC Calibration Register.
GPIOA4	12	8	—	Input	Input/ Output	GPIO Port A4 — After reset, the default state is GPIOA4.
(ANA40 & CMPA_IN4)					Input	ANA40 — ADCA channel 4 expansion MUX input 40. CMPA_IN4 — Analog comparator A input 4. When used as an analog input, the signal goes to ANA40 and CMPA_IN4. ¹
GPIOA5	11	—	—	Input	Input/ Output	GPIO Port A5 — After reset, the default state is GPIOA5.
(ANA5 & CMPB_IN4)					Input	ANA5 — ADCA channel 5 input. CMPB_IN4 — Analog comparator B input 4. When used as an analog input, the signal goes to ANA5 and CMPB_IN4. ¹
GPIOA6	10	—	—	Input	Input/ Output	GPIO Port A6 — After reset, the default state is GPIOA6.
(ANA6 & CMPC_IN4 & OPAMPA_IN1)					Input	ANA6 — ADCA channel 6 input. CMPC_IN4 — Analog comparator C input 4. OPAMPA_IN1 — Operational amplifier A input 1. When used as an analog input, the signal goes to ANA6 and CMPC_IN4 and OPAMPA_IN1. ¹
GPIOA7	9	—	—	Input	Input/ Output	GPIO Port A7 — After reset, the default state is GPIOA7.

Table continues on the next page...

Table 2. Signal descriptions (continued)

Signal Name	64 LQFP	48 LQFP	32 LQFP/QFN	State During Reset	Type	Signal Description
(ANA7 & OPAMPA_IN2)					Input	ANA7 — ADCA channel 7 input. OPAMPA_IN2 — Operational amplifier A input 2. When used as an analog input, the signal goes to ANA7 and OPAMPA_IN2. ¹
GPIOB0	24	17	11	Input	Input/Output	GPIO Port B0 — After reset, the default state is GPIOB0.
(ANB0 & CMPB_IN3 & OPAMPB_IN3)					Input	ANB0 — ADCB channel 0 input. CMPB_IN3 — Analog comparator B input 3. OPAMPB_IN3 — Operational amplifier B input 3. When used as an analog input, the signal goes to ANB0 and CMPB_IN3 and OPAMPB_IN3. ¹
GPIOB1	25	18	12	Input	Input/Output	GPIO Port B1 — After reset, the default state is GPIOB1.
(ANB1 & CMPB_IN0 & OPAMPB_IN0)					Input	ANB1 — ADCB channel 1 input. CMPB_IN0 — Analog comparator B input 0. OPAMPB_IN0 — Operational amplifier B input 0. When used as an analog input, the signal goes to ANB1 and CMPB_IN0 and OPAMPB_IN0. ¹
GPIOB2	27	20	13	Input	Input/Output	GPIO Port B2 — After reset, the default state is GPIOB2.
(ANB2 & VREFHB & CMPC_IN3)					Input	ANB2 — ADCB channel 2 input. VREFHB — ADCB analog reference high. CMPC_IN3 — Analog comparator C input 3. When used as an analog input, the signal goes to ANB2 (or VREFHB) and CMPC_IN3. ¹ NOTE: ADC input can be configured as either ANB2 or VREFHB in the ADC Calibration Register.
GPIOB3	28	21	—	Input	Input/Output	GPIO Port B3 — After reset, the default state is GPIOB3.
(ANB3 & VREFLB & CMPC_IN0)					Input	ANB3 — ADCB channel 3 input. VREFLB — ADCB analog reference low. CMPC_IN0 — Analog comparator C input 0. When used as an analog input, the signal goes to ANB3 (or VREFHB) and CMPC_IN0. ¹ NOTE: ADC input can be configured as either ANB3 or VREFLB in the ADC Calibration Register.
GPIOB4	21	14	—	Input	Input/Output	GPIO Port B4 — After reset, the default state is GPIOB4.
(ANB40 & CMPC_IN1)					Input	ANB40 — ADCB channel 4 expansion MUX input 40. CMPC_IN1 — Analog comparator C input 1.

Table continues on the next page...

Table 2. Signal descriptions (continued)

Signal Name	64 LQFP	48 LQFP	32 LQFP/QFN	State During Reset	Type	Signal Description
CMPC_IN1)						When used as an analog input, the signal goes to ANB40 and CMPC_IN1. ¹
GPIOB5	20	—	—	Input	Input/Output	GPIO Port B5 — After reset, the default state is GPIOB5.
(ANB5 & CMPC_IN2)					Input	ANB5 — ADCB channel 5 input. CMPC_IN2 — Analog comparator C input 2. When used as an analog input, the signal goes to ANB5 and CMPC_IN2. ¹
GPIOB6	19	—	—	Input	Input/Output	GPIO Port B6 — After reset, the default state is GPIOB6.
(ANB6 & CMPB_IN1 & OPAMPB_IN1)					Input	ANB6 — ADCB channel 6 input. CMPB_IN1 — Analog comparator B input 1. OPAMPB_IN1 — Operational amplifier B input 1. When used as an analog input, the signal goes to ANB6 and CMPB_IN1 and OPAMPB_IN1. ¹
GPIOB7	17	—	—	Input	Input/Output	GPIO Port B7 — After reset, the default state is GPIOB7.
(ANB7 & CMPB_IN2 & OPAMPB_IN2)					Input	ANB7 — ADCB channel 7 input. CMPB_IN2 — Analog comparator B input 2. OPAMPB_IN2 — Operational amplifier B input 2. When used as an analog input, the signal goes to ANB7 and CMPB_IN2 and OPAMPB_IN2. ¹
GPIOC0	3	3	—	Input	Input/Output	GPIO Port C0 — After reset, the default state is GPIOC0.
(EXTAL)					Input	External crystal oscillator input (EXTAL) connects the internal crystal oscillator input to an external crystal or ceramic resonator.
(CLKIN0)					Input	External clock input 0 to OCCS. NOTE: If this pin is selected as the device's external clock input, then both SIM_GPSCl[C0] bit in SIM and OSCTL1[EXT_SEL] bit in OCCS must be set. The crystal oscillator should be powered down.
GPIOC1	4	4	—	Input	Input/Output	GPIO Port C1 — After reset, the default state is GPIOC1.
(XTAL)					Output	External crystal oscillator output (XTAL) connects the internal crystal oscillator output to an external crystal or ceramic resonator.
GPIOC2	5	5	3	Input	Input/Output	GPIO Port C2 — After reset, the default state is GPIOC2.
(TXD0)					Output	SCI0 transmit data output or transmit/receive in single wire operation.

Table continues on the next page...

Table 2. Signal descriptions (continued)

Signal Name	64 LQFP	48 LQFP	32 LQFP/QFN	State During Reset	Type	Signal Description
(XB_OUT11)					Output	Crossbar module output 11.
(XB_IN2)					Input	Crossbar module input 2.
(CLKO0)					Output	Buffered clock output 0. NOTE: The clock source is selected by SIM_CLKOUT[CLKOSEL0] bits in SIM.
GPIOC3	7	6	4	Input	Input/Output	GPIO Port C3 — After reset, the default state is GPIOC3.
(TA0)					Input/Output	Quad timer channel 0 input/output.
(CMPA_O)					Output	Analog comparator A output.
(RXD0)					Input	SCI0 receive data input.
(CLKIN1)					Input	External clock input 1 to OCCS. NOTE: If this pin is selected as device's external clock input, then both SIM_GPSCL[C3] bits in SIM and OSCTL1[EXT_SEL] bit in OCCS must be set.
GPIOC4	8	7	5	Input	Input/Output	GPIO Port C4 — After reset, the default state is GPIOC4.
(TA1)					Input/Output	Quad timer channel 1 input/output.
(CMPB_O)					Output	Analog comparator B output.
(XB_IN8)					Input	Crossbar module input 8.
(OPAMPA_OUT)					Output	Operational amplifier A output.
GPIOC5	18	13	—	Input	Input/Output	GPIO Port C5 — After reset, the default state is GPIOC5.
(ANB4d)					Input	ADCB channel 4 expansion MUX input 4d.
(XB_IN7)					Input	Crossbar module input 7.
GPIOC6	31	23	15	Input	Input/Output	GPIO Port C6 — After reset, the default state is GPIOC6.
(TA2)					Input/Output	Quad timer channel 2 input/output.
(XB_IN3)					Input	Crossbar module input 3.
(CMP_REF)					Input	Input 5 of analog comparator A and B and C.
(SS0_B)					Input/Output	SPI0 slave select.
GPIOC7	32	24	—	Input	Input/Output	GPIO Port C7 — After reset, the default state is GPIOC7.
(SS0_B)					Input/Output	SPI0 slave select.
(TXD0)					Output	SCI0 transmit data output or transmit/receive in single wire operation.
(XB_IN8)					Input	Crossbar module input 8.

Table continues on the next page...

Table 2. Signal descriptions (continued)

Signal Name	64 LQFP	48 LQFP	32 LQFP/QFN	State During Reset	Type	Signal Description
(XB_OUT6)					Output	Crossbar module output 6.
GPIOC8	33	25	16	Input	Input/Output	GPIO Port C8 — After reset, the default state is GPIOC8.
(MISO0)					Input/Output	SPI0 master in/slave out.
(RXD0)					Input	SCI0 receive data input.
(XB_IN9)					Input	Crossbar module input 9.
GPIOC9	34	26	17	Input	Input/Output	GPIO Port C9 — After reset, the default state is GPIOC9.
(SCLK0)					Input/Output	SPI0 serial clock.
(XB_IN4)					Input	Crossbar module input 4.
(TXD0)					Output	SCI0 transmit data output or transmit/receive in single wire operation.
(XB_OUT8)					Output	Crossbar module output 8.
GPIOC10	35	27	18	Input	Input/Output	GPIO Port C10 — After reset, the default state is GPIOC10.
(MOSI0)					Input/Output	SPI0 master out/slave.
(XB_IN5)					Input	Crossbar module input 5.
(MISO0)					Input/Output	SPI0 master in/slave out.
(XB_OUT9)					Output	Crossbar module output 9.
GPIOC11	37	29	—	Input	Input/Output	GPIO Port C11 — After reset, the default state is GPIOC11.
(LP_SCLS0)					Output	I ² C0 secondary serial clock line. NOTE: In 4-wire mode, this is the I ² C slave SCL output for voltage level shift.
(ANB4b)					Input	ADCB channel 4 expansion MUX input 4b.
(TXD1)					Output	SCI1 transmit data output or transmit/receive in single wire operation.
(PWMA_0X)					Output	PWM submodule 0, output X or input capture X.
GPIOC12	38	30	—	Input	Input/Output	GPIO Port C12 — After reset, the default state is GPIOC12.
(LP_SDAS0)					Output	I ² C0 secondary serial data line. NOTE: In 4-wire mode, this is the I ² C slave SDA output for voltage level shift.
(ANA4b)					Input	ADCA channel 4 expansion MUX input 4b.
(RXD1)					Input	SCI1 receive data input
(PWMA_1X)					Output	PWM submodule 1, output X or input capture X.
GPIOC13	49	37	—	Input	Input/Output	GPIO Port C13 — After reset, the default state is GPIOC13.

Table continues on the next page...

Table 2. Signal descriptions (continued)

Signal Name	64 LQFP	48 LQFP	32 LQFP/QFN	State During Reset	Type	Signal Description
(TA3)					Input/Output	Quad timer channel 3 input/output.
(XB_IN6)					Input	Crossbar module input 6.
(EWM_OUT_B)					Output	External Watchdog Module output.
GPIOC14	55	41	—	Input	Input/Output	GPIO Port C14 — After reset, the default state is GPIOC14.
(LP_SDA0)					Input/Open-drain Output	I ² C0 serial data line NOTE: In 4-wire mode, this is the I ² C slave SDA input.
(XB_OUT4)					Output	Crossbar module output 4.
(PWMA_FAULT4)					Input	PWM Fault input 4 for disabling selected PWM outputs.
(ANB4c)					Input	ADCB channel 4 expansion MUX input 4c.
GPIOC15	56	42	—	Input	Input/Output	GPIO Port C15: After reset, the default state is GPIOC15.
(LP_SCL0)					Input/Open-drain Output	I ² C0 serial clock line NOTE: In 4-wire mode, this is the I ² C slave SCL input.
(XB_OUT5)					Output	Crossbar module output 5.
(PWMA_FAULT5)					Input	PWM Fault input 5 for disabling selected PWM outputs.
ANA4c					Input	ADCA channel 4 expansion MUX input 4c.
GPIOE0	45	33	21	Input	Input/Output	GPIO Port E0 — After reset, the default state is GPIOE0.
(PWMA_0B)					Input/Output	PWM submodule 0, high resolution output B or input capture B.
XB_OUT4					Output	Crossbar module output 4.
GPIOE1	46	34	22	Input	Input/Output	GPIO Port E1 — After reset, the default state is GPIOE1.
(PWMA_0A)					Input/Output	PWM submodule 0, high resolution output A or input capture A.
(XB_OUT5)					Output	Crossbar module output 5.
GPIOE2	47	35	23	Input	Input/Output	GPIO Port E2 — After reset, the default state is GPIOE2.
(PWMA_1B)					Input/Output	PWM submodule 1, high resolution output B or input capture B.
XB_OUT6					Output	Crossbar module output 6.
GPIOE3	48	36	24	Input	Input/Output	GPIO Port E3 — After reset, the default state is GPIOE3.
(PWMA_1A)					Input/Output	PWM submodule 1, high resolution output A or input capture A.
(XB_OUT7)					Output	Crossbar module output 7.

Table continues on the next page...

Table 2. Signal descriptions (continued)

Signal Name	64 LQFP	48 LQFP	32 LQFP/QFN	State During Reset	Type	Signal Description
GPIOE4	51	39	25	Input	Input/Output	GPIO Port E4 — After reset, the default state is GPIOE4.
(PWMA_2B)					Input/Output	PWM submodule 2, high resolution output B or input capture B.
(XB_IN2)					Input	Crossbar module input 2
(XB_OUT8)					Output	Crossbar module output 8.
GPIOE5	52	40	26	Input	Input/Output	GPIO Port E5 — After reset, the default state is GPIOE5.
(PWMA_2A)					Input/Output	PWM submodule 2, high resolution output A or input capture A
(XB_IN3)					Input	Crossbar module input 3.
(XB_OUT9)					Output	Crossbar module output 9.
GPIOE6	53	—	—	Input	Input/Output	GPIO Port E6 — After reset, the default state is GPIOE6.
(PWMA_3B)					Input/Output	PWM submodule 3, high resolution output B or input capture B.
(XB_IN4)					Input	Crossbar module input 4
(ANB4e)					Input	ADCB channel 4 expansion MUX input 4e.
(XB_OUT10)					Output	Crossbar module output 10.
GPIOE7	54	—	—	Input	Input/Output	GPIO Port E7 — After reset, the default state is GPIOE7.
(PWMA_3A)					Input/Output	PWM ,submodule 3, high resolution output A or input capture A.
(XB_IN5)					Input	Crossbar module input 5.
(ANA4e)					Input	ADCA channel 4 expansion MUX input 4e.
(XB_OUT11)					Output	Crossbar module output 11.
GPIOF0	36	28	—	Input	Input/Output	GPIO Port F0 — After reset, the default state is GPIOF0.
(XB_IN6)					Input	Crossbar module input 6
(OPAMPB_OUT)					Output	Operational amplifier B output.
GPIOF1	50	38	—	Input	Input/Output	GPIO Port F1 — After reset, the default state is GPIOF1.
(CLKO1)					Output	Buffered clock output 1. NOTE: The clock source is selected by SIM_CLKOUT[CLKOSEL1] bits in SIM.
(XB_IN7)					Input	Crossbar module input 7.
(ANA4d)					Input	ADCA channel 4 expansion MUX input 4d.
GPIOF2	39	—	19	Input	Input/Output	GPIO Port F2 — After reset, the default state is GPIOF2.
(ANA4a)					Input	ADCA channel 4 expansion MUX input 4a.
(XB_OUT6)					Output	Crossbar module output 6

Table continues on the next page...

Table 2. Signal descriptions (continued)

Signal Name	64 LQFP	48 LQFP	32 LQFP/QFN	State During Reset	Type	Signal Description
(LP_SDA0)					Input/ Open- drain Output	I ² C0 serial data line. NOTE: In 4-wire mode, this is the I ² C slave SDA input.
GPIOF3	40	—	20	Input	Input/ Output	GPIO Port F3 — After reset, the default state is GPIOF3.
(ANB4a)					Input	ADCB channel 4 expansion MUX input 4a.
(XB_OUT7)					Output	Crossbar module output 7
(LP_SCL0)					Input/ Output	I ² C0 serial clock line NOTE: In 4-wire mode, this is the I ² C slave SCL input.
GPIOF4	41	—	—	Input	Input/ Output	GPIO Port F4 — After reset, the default state is GPIOF4.
(TXD1)					Output	SCI1 transmit data output or transmit/receive in single wire operation
(XB_OUT8)					Output	Crossbar module output 8
(PWMA_0X)					Input/ Output	PWM submodule 0, output X or input capture X.
(PWMA_FAULT6)					Input	PWM Fault input 6 for disabling selected PWM outputs.
GPIOF5	42	—	—	Input	Input/ Output	GPIO Port F5 — After reset, the default state is GPIOF5.
(RXD1)					Input	SCI1 receive data input.
(XB_OUT9)					Output	Crossbar module output 9.
(PWMA_1X)					Input/ Output	PWM submodule 1, output X or input capture X.
(PWMA_FAULT7)					Input	PWM Fault input 7 for disabling selected PWM outputs.
GPIOF6	58	—	—	Input	Input/ Output	GPIO Port F6 — After reset, the default state is GPIOF6.
(ANB4f)					Input	ADCB channel 4 expansion MUX input 4f.
(PWMA_3X)					Input/ Output	PWM submodule 3, output X or input capture X.
(XB_IN2)					Input	Crossbar module input 2.
GPIOF7	59	—	—	Input	Input/ Output	GPIO Port F7 — After reset, the default state is GPIOF7.
(ANA4f)					Input	ADCA channel 4 expansion MUX input 4f.
(CMPC_O)					Output	Analog comparator C output.
(XB_IN3)					Input	Crossbar module input 3.
GPIOF8	6	—	—	Input	Input/ Output	GPIO Port F8 — After reset, the default state is GPIOF8.
(RXD0)					Input	SCI0 receive data input.
(XB_OUT10)					Output	Crossbar module output 10.
(CMPD_O)					Output	Analog comparator D output.
(PWMA_2X)					Output	PWM submodule 2, output X or input capture X.

- The glitch on this pin during ADC sampling may interfere with other analog inputs shared on this pin.

3 Signal groups

The input and output signals of this device are organized into functional groups, as detailed in the following table.

Table 3. Functional Group Pin Allocations

Functional Group	Number of Pins		
	32LQFP	48LQFP	64LQFP
Power Inputs (V_{DD} , V_{DDA}), Power output(V_{CAP})	3	5	6
Ground (V_{SS} , V_{SSA})	3	4	4
Reset	1	1	1
eFlexPWM outputs high resolution PWM	6	6	8
eFlexPWM outputs without high resolution PWM	0	2	6
Queued Serial Peripheral Interface (QSPI0) ports	4	5	5
Queued Serial Communications Interface (QSCI0 and QSCI1 ¹) ports	4	7	10
Inter-Integrated Circuit Interface (LPI ² C0) ports	2 ²	4 ³	6
12-bit Analog-to-Digital Converter (ADC) inputs	8	16	28
Analog Comparator inputs/outputs	7/3	11/3	16/4
Analog Operational Amplifier inputs/outputs	4/1	4/2	8/2
Quad Timer Module (TMR) ports	3	4	4
Inter-Module Crossbar inputs/outputs	8/11	13/12	17/19
Clock inputs/outputs	1/1	2/2	2/2
JTAG / Enhanced On-Chip Emulation (EOnCE)	4	4	4

- QSCI1 is not available in the 32-pin package.
- 4-wire mode is not supported.
- Only LPI²C0 supports 4-wire mode.

4 Pinout

4.1 Signal Multiplexing and Pin Assignments

The following table shows the signals available on each pin and the locations of these pins on the devices supported by this document. The Port Control Module is responsible for selecting which ALT functionality is available on each pin.

64 LQFP	48 LQFP	32 LQFP	Pin Name	Default	ALT0	ALT1	ALT2	ALT3
1	1	1	TCK	TCK	GPIO2			

Pinout

64 LQFP	48 LQFP	32 LQFP	Pin Name	Default	ALT0	ALT1	ALT2	ALT3
2	2	2	RESET_B	RESET_B	GPIOD4			
3	3	—	GPIOC0	GPIOC0	EXTAL	CLKIN0		
4	4	—	GPIOC1	GPIOC1	XTAL			
5	5	3	GPIOC2	GPIOC2	TXD0	XB_OUT11	XB_IN2	CLKO0
6	—	—	GPIOF8	GPIOF8	RXD0	XB_OUT10		PWMA_2X
7	6	4	GPIOC3	GPIOC3	TA0	CMPA_O	RXD0	CLKIN1
8	7	5	GPIOC4	GPIOC4	TA1	CMPB_O	XB_IN8	OPAMPA_OUT
9	—	—	GPIOA7	GPIOA7	ANA7+OPAMPA_IN2			
10	—	—	GPIOA6	GPIOA6	ANA6+OPAMPA_IN1+CMPC_IN4			
11	—	—	GPIOA5	GPIOA5	ANA5+CMPB_IN4			
12	8	—	GPIOA4	GPIOA4	ANA40+CMPA_IN4			
13	9	6	GPIOA0	GPIOA0	ANA0+CMPA_IN3+OPAMPA_IN3	CMPC_O		
14	10	7	GPIOA1	GPIOA1	ANA1+CMPA_IN0+OPAMPA_IN0			
15	11	8	GPIOA2	GPIOA2	ANA2+VREFHA+CMPA_IN1			
16	12	—	GPIOA3	GPIOA3	ANA3+VREFLA+CMPA_IN2			
17	—	—	GPIOB7	GPIOB7	ANB7+CMPB_IN2+OPAMPB_IN2			
18	13	—	GPIOC5	GPIOC5	ANB4d	XB_IN7		
19	—	—	GPIOB6	GPIOB6	ANB6+CMPB_IN1+OPAMPB_IN1			
20	—	—	GPIOB5	GPIOB5	ANB5+CMPC_IN2			
21	14	—	GPIOB4	GPIOB4	ANB40+CMPC_IN1			
22	15	9	VDDA	VDDA				
23	16	10	VSSA	VSSA				
24	17	11	GPIOB0	GPIOB0	ANB0+CMPB_IN3+OPAMPB_IN3			
25	18	12	GPIOB1	GPIOB1	ANB1+CMPB_IN0+OPAMPB_IN0			
26	19	—	VCAP	VCAP				
27	20	13	GPIOB2	GPIOB2	ANB2+VREFHB+CMPC_IN3			
28	21	—	GPIOB3	GPIOB3	ANB3+VREFLB+CMPC_IN0			
29	—	—	VDD	VDD				
30	22	14	VSS	VSS				
31	23	15	GPIOC6	GPIOC6	TA2	XB_IN3	CMP_REF	SS0_B
32	24	—	GPIOC7	GPIOC7	SS0_B	TXD0	XB_IN8	XB_OUT6
33	25	16	GPIOC8	GPIOC8	MISO0	RXD0	XB_IN9	
34	26	17	GPIOC9	GPIOC9	SCLK0	XB_IN4	TXD0	XB_OUT8

64 LQFP	48 LQFP	32 LQFP	Pin Name	Default	ALT0	ALT1	ALT2	ALT3
35	27	18	GPIOC10	GPIOC10	MOSI0	XB_IN5	MISO0	XB_OUT9
36	28	—	GPIOF0	GPIOF0	XB_IN6			OPAMPB_OUT
37	29	—	GPIOC11	GPIOC11	LP_SCLS0	ANB4b	TXD1	PWMA_0X
38	30	—	GPIOC12	GPIOC12	LP_SDAS0	ANA4b	RXD1	PWMA_1X
39	—	19	GPIOF2	GPIOF2	ANA4a	XB_OUT6	LP_SDA0	
40	—	20	GPIOF3	GPIOF3	ANB4a	XB_OUT7	LP_SCL0	
41	—	—	GPIOF4	GPIOF4	TXD1	XB_OUT8	PWMA_0X	PWMA_FAULT6
42	—	—	GPIOF5	GPIOF5	RXD1	XB_OUT9	PWMA_1X	PWMA_FAULT7
43	31	—	VSS	VSS				
44	32	—	VDD	VDD				
45	33	21	GPIOE0	GPIOE0	PWMA_0B			XB_OUT4
46	34	22	GPIOE1	GPIOE1	PWMA_0A			XB_OUT5
47	35	23	GPIOE2	GPIOE2	PWMA_1B			XB_OUT6
48	36	24	GPIOE3	GPIOE3	PWMA_1A			XB_OUT7
49	37	—	GPIOC13	GPIOC13	TA3	XB_IN6	EWM_OUT_B	
50	38	—	GPIOF1	GPIOF1	CLKO1	XB_IN7	ANA4d	
51	39	25	GPIOE4	GPIOE4	PWMA_2B	XB_IN2		XB_OUT8
52	40	26	GPIOE5	GPIOE5	PWMA_2A	XB_IN3		XB_OUT9
53	—	—	GPIOE6	GPIOE6	PWMA_3B	XB_IN4	ANB4e	XB_OUT10
54	—	—	GPIOE7	GPIOE7	PWMA_3A	XB_IN5	ANA4e	XB_OUT11
55	41	—	GPIOC14	GPIOC14	LP_SDA0	XB_OUT4	PWMA_FAULT4	ANB4c
56	42	—	GPIOC15	GPIOC15	LP_SCL0	XB_OUT5	PWMA_FAULT5	ANA4c
57	43	27	VCAP	VCAP				
58	—	—	GPIOF6	GPIOF6	ANB4f	PWMA_3X		XB_IN2
59	—	—	GPIOF7	GPIOF7	ANA4f	CMPC_O		XB_IN3
60	44	28	VDD	VDD				
61	45	29	VSS	VSS				
62	46	30	TDO	TDO	GPIOD1			
63	47	31	TMS	TMS	GPIOD3			
64	48	32	TDI	TDI	GPIOD0			

4.2 Pinout diagrams

The following diagrams show pinouts for the packages. For each pin, the diagrams show the default function. However, many signals may be multiplexed onto a single pin.

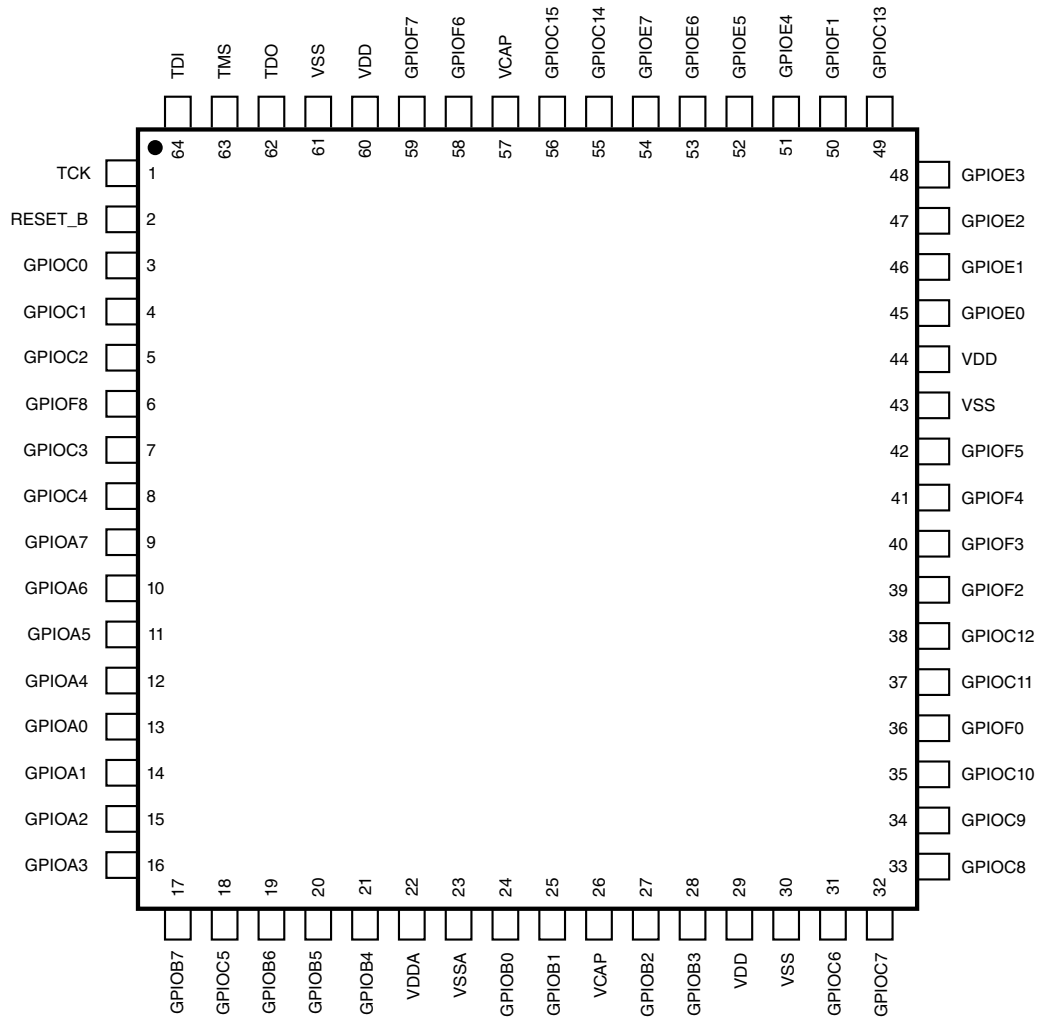

Figure 2. 64-pin LQFP

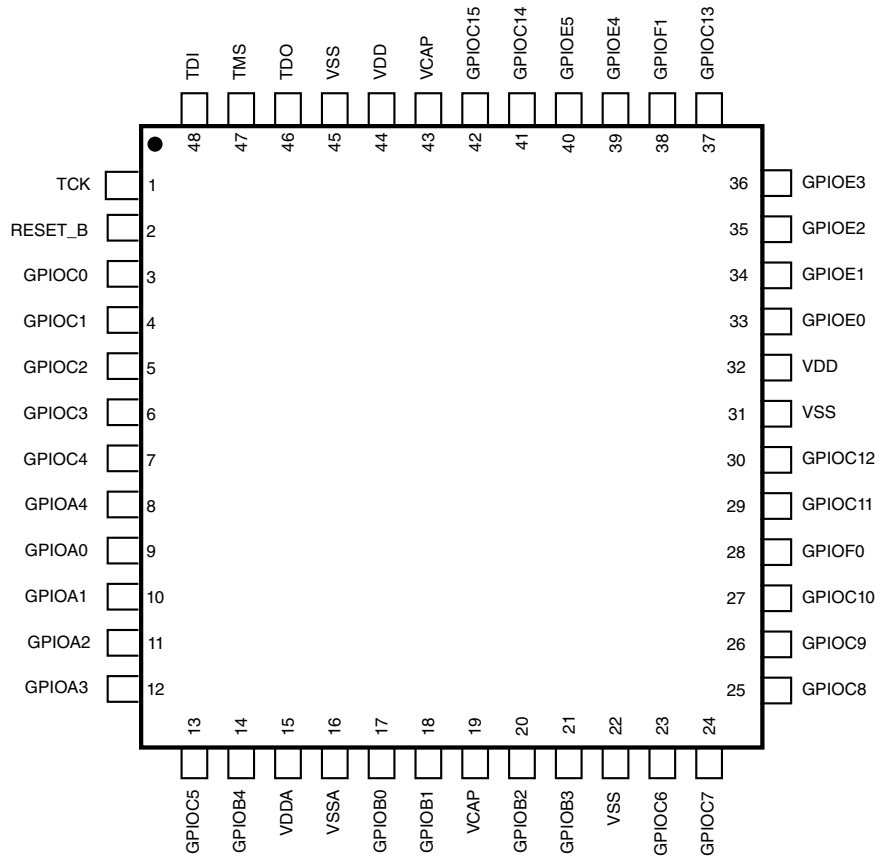

Figure 3. 48-pin LQFP

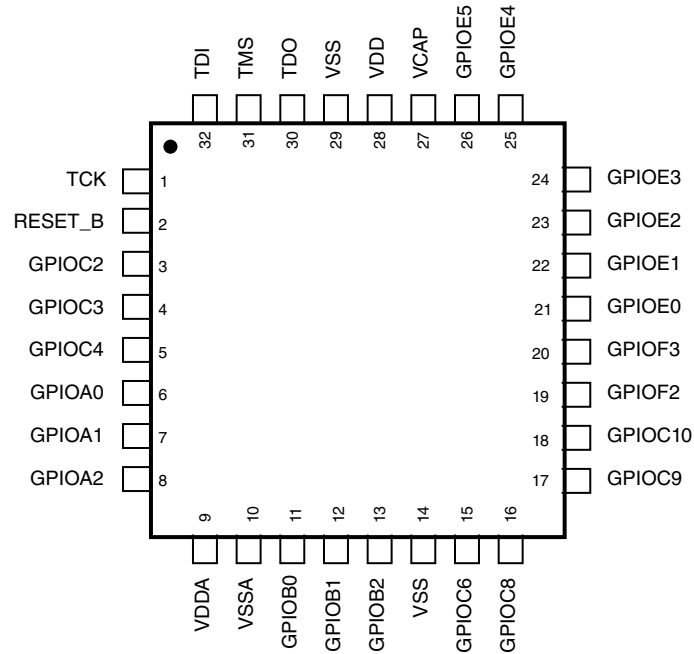

Figure 4. 32-pin LQFP

5 Ordering parts

5.1 Determining valid orderable parts

Valid orderable part numbers are provided on the web. To determine the orderable part numbers for this device, go to nxp.com and perform a part number search for the following device numbers: MC56F80

5.2 Part number list

The following table shows a part number list for this device.

Table 4. Part numbers

Part Number	Flash	RAM	High-resolution PWM	Operating Temperature	Package ¹
MC56F80748VLH	64 KB	8 KB	Yes	-40 to 105°C	64 LQFP
MC56F80738VLH	48 KB	8 KB	Yes	-40 to 105°C	64 LQFP
MC56F80746VLF	64 KB	8 KB	Yes	-40 to 105°C	48 LQFP
MC56F80736VLF	48 KB	8 KB	Yes	-40 to 105°C	48 LQFP
MC56F80726VLF	32 KB	6 KB	Yes	-40 to 105°C	48 LQFP
MC56F80743VLC	64 KB	8 KB	Yes	-40 to 105°C	32 LQFP
MC56F80723VLC	32 KB	6 KB	Yes	-40 to 105°C	32 LQFP
MC56F80743VFM	64 KB	8 KB	Yes	-40 to 105°C	32 QFN
MC56F80733VFM	48 KB	8 KB	Yes	-40 to 105°C	32 QFN
MC56F80648VLH	64 KB	8 KB	—	-40 to 105°C	64 LQFP
MC56F80646VLF	64 KB	8 KB	—	-40 to 105°C	48 LQFP
MC56F80626VLF	32 KB	6 KB	—	-40 to 105°C	48 LQFP
MC56F80643VLC	64 KB	8 KB	—	-40 to 105°C	32 LQFP
MC56F80623VLC	32 KB	6 KB	—	-40 to 105°C	32 LQFP
MC56F80748MLH	64 KB	8 KB	Yes	-40 to 125°C	64 LQFP
MC56F80746MLF	64 KB	8 KB	Yes	-40 to 125°C	48 LQFP

1. The 32 LQFP and 32 QFN packages for this product are not yet available. However, the pin-out and pricing information of these packages are readily available. These devices are then committed for sampling and production based on customer demand.

6 Part identification

6.1 Description

Part numbers for the chip have fields that identify the specific part. You can use the values of these fields to determine the specific part you have received.

6.2 Format

Part numbers for this device have the following format: Q 56F8 0 C F P T PP N

6.3 Fields

This table lists the possible values for each field in the part number (not all combinations are valid):

Terminology and guidelines

Field	Description	Values
Q	Qualification status	<ul style="list-style-type: none">• MC = Fully qualified, general market flow• PC = Prequalification
56F8	DSC family with flash memory and DSP56800/ DSP56800E/DSP56800EX/DSP56800EF core	<ul style="list-style-type: none">• 56F8
0	DSC subfamily	<ul style="list-style-type: none">• 0
C	Maximum CPU frequency (MHz)	<ul style="list-style-type: none">• 6 = 100 MHz• 7 = 100 MHz
F	Primary program flash memory size	<ul style="list-style-type: none">• 2 = 32 KB• 3 = 48 KB• 4 = 64 KB
P	Pin count	<ul style="list-style-type: none">• 3 = 32• 6 = 48• 8 = 64
T	Temperature range (°C)	<ul style="list-style-type: none">• V = -40 to 105• M = -40 to 125
PP	Package identifier	<ul style="list-style-type: none">• LC = 32LQFP• FM = 32QFN• LF = 48LQFP• LH = 64LQFP
N	Packaging type	<ul style="list-style-type: none">• R = Tape and reel• (Blank) = Trays

6.4 Example

This is an example part number: MC56F80748VLH

7 Terminology and guidelines

7.1 Definition: Operating requirement

An *operating requirement* is a specified value or range of values for a technical characteristic that you must guarantee during operation to avoid incorrect operation and possibly decreasing the useful life of the chip.

7.1.1 Example

This is an example of an operating requirement:

Symbol	Description	Min.	Max.	Unit
V _{DD}	1.0 V core supply voltage	0.9	1.1	V

7.2 Definition: Operating behavior

Unless otherwise specified, an *operating behavior* is a specified value or range of values for a technical characteristic that are guaranteed during operation if you meet the operating requirements and any other specified conditions.

7.2.1 Example

This is an example of an operating behavior:

Symbol	Description	Min.	Max.	Unit
I _{WP}	Digital I/O weak pullup/pulldown current	10	130	μA

7.3 Definition: Attribute

An *attribute* is a specified value or range of values for a technical characteristic that are guaranteed, regardless of whether you meet the operating requirements.

7.3.1 Example

This is an example of an attribute:

Symbol	Description	Min.	Max.	Unit
CIN_D	Input capacitance: digital pins	—	7	pF

7.4 Definition: Rating

A *rating* is a minimum or maximum value of a technical characteristic that, if exceeded, may cause permanent chip failure:

Terminology and guidelines

- *Operating ratings* apply during operation of the chip.
- *Handling ratings* apply when the chip is not powered.

7.4.1 Example

This is an example of an operating rating:

Symbol	Description	Min.	Max.	Unit
V _{DD}	1.0 V core supply voltage	-0.3	1.2	V

7.5 Result of exceeding a rating

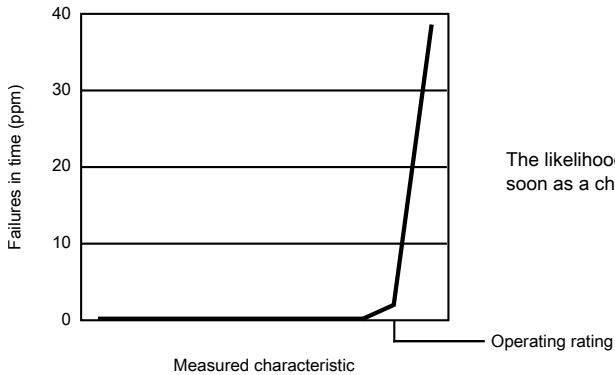

The likelihood of permanent chip failure increases rapidly as soon as a characteristic begins to exceed one of its operating ratings.

7.6 Relationship between ratings and operating requirements

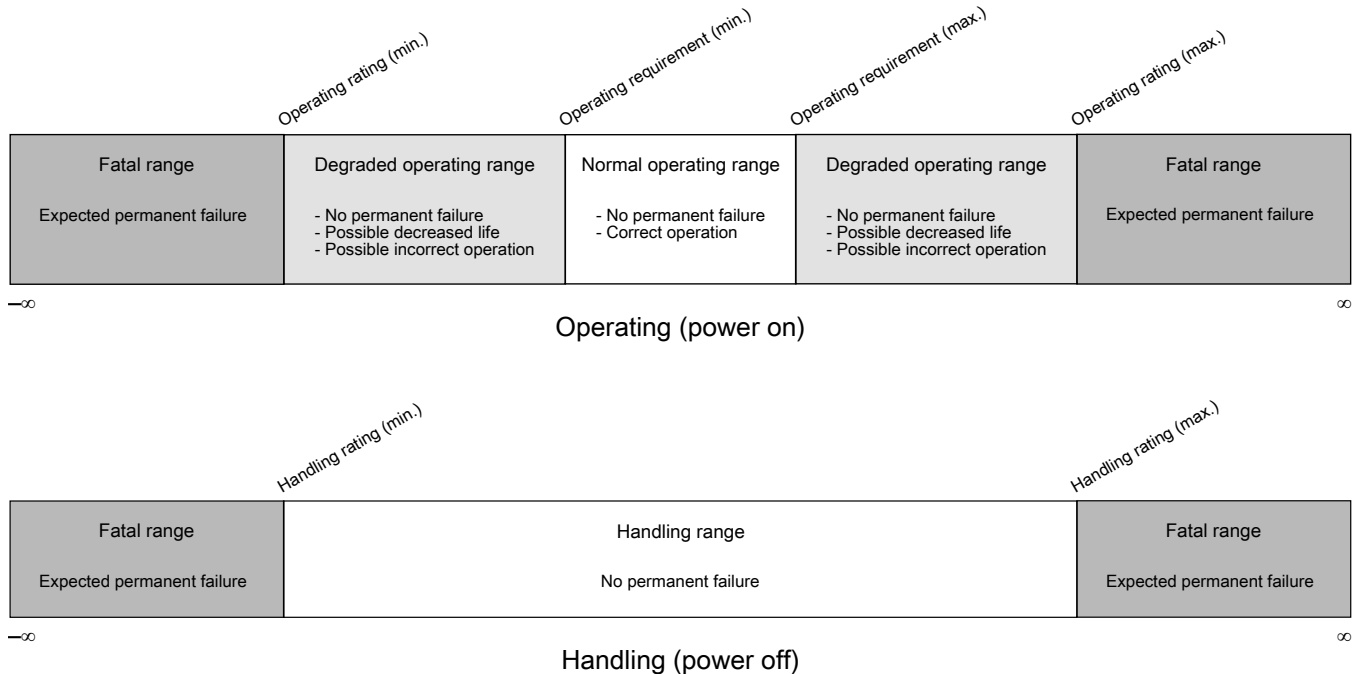

7.7 Guidelines for ratings and operating requirements

Follow these guidelines for ratings and operating requirements:

- Never exceed any of the chip's ratings.
- During normal operation, don't exceed any of the chip's operating requirements.
- If you must exceed an operating requirement at times other than during normal operation (for example, during power sequencing), limit the duration as much as possible.

7.8 Definition: Typical value

A *typical value* is a specified value for a technical characteristic that:

- Lies within the range of values specified by the operating behavior
- Given the typical manufacturing process, is representative of that characteristic during operation when you meet the typical-value conditions or other specified conditions

Typical values are provided as design guidelines and are neither tested nor guaranteed.

7.8.1 Example 1

This is an example of an operating behavior that includes a typical value:

Symbol	Description	Min.	Typ.	Max.	Unit
I_{WP}	Digital I/O weak pullup/pulldown current	10	70	130	μA

7.8.2 Example 2

This is an example of a chart that shows typical values for various voltage and temperature conditions:

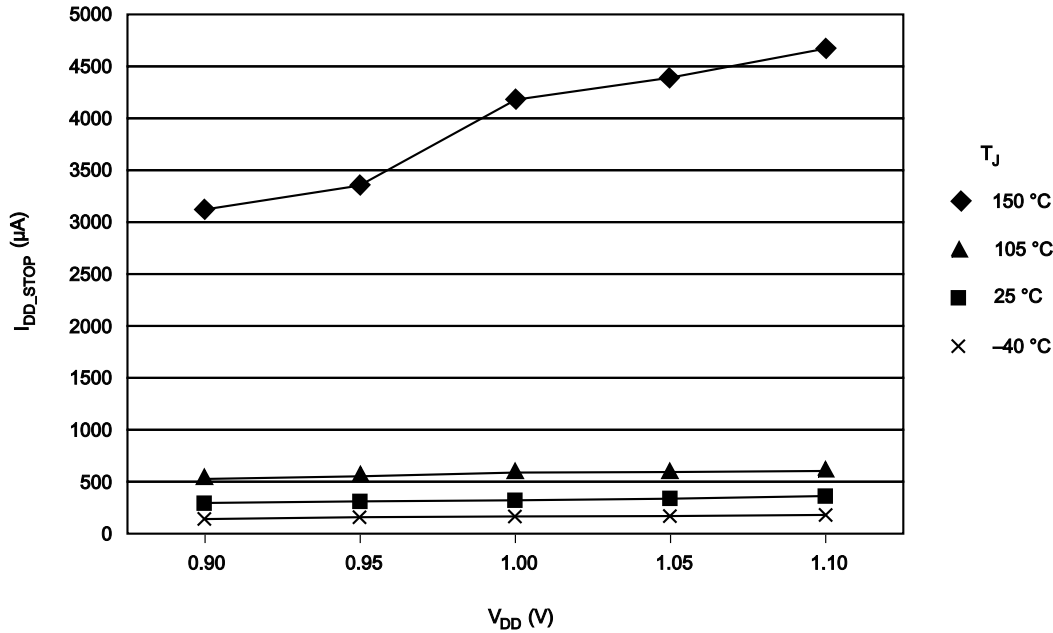

7.9 Typical value conditions

Typical values assume you meet the following conditions (or other conditions as specified):

Symbol	Description	Value	Unit
T_A	Ambient temperature	25	$^{\circ}\text{C}$
V_{DD}	3.3 V supply voltage	3.3	V

8 Ratings

8.1 Thermal handling ratings

Symbol	Description	Min.	Max.	Unit	Notes
T _{STG}	Storage temperature	-55	150	°C	1
T _{SDR}	Solder temperature, lead-free	—	260	°C	2

1. Determined according to JEDEC Standard JESD22-A103, *High Temperature Storage Life*.
2. Determined according to IPC/JEDEC Standard J-STD-020, *Moisture/Reflow Sensitivity Classification for Nonhermetic Solid State Surface Mount Devices*.

8.2 Moisture handling ratings

Symbol	Description	Min.	Max.	Unit	Notes
MSL	Moisture sensitivity level	—	3	—	1

1. Determined according to IPC/JEDEC Standard J-STD-020, *Moisture/Reflow Sensitivity Classification for Nonhermetic Solid State Surface Mount Devices*.

8.3 ESD and latch-up ratings

Although damage from electrostatic discharge (ESD) is much less common on these devices than on early CMOS circuits, use normal handling precautions to avoid exposure to static discharge. Qualification tests are performed to ensure that these devices can withstand exposure to reasonable levels of static without suffering any permanent damage.

A device is defined as a failure if after exposure to ESD pulses, the device no longer meets the device specification. Complete DC parametric and functional testing is performed as per the applicable device specification at room temperature followed by hot temperature, unless specified otherwise in the device specification.

Table 5. ESD and latch-up ratings

Characteristic Description ¹	Rating	Notes
Electrostatic discharge voltage, human body model	±2000 V	2
Electrostatic discharge voltage, charged device model	±500 V	3
Latch-up immunity level (Class II at 135 °C junction temperature)	Immunity Level A	4

General

1. Parameter is achieved by design characterization on a small sample size from typical devices under typical conditions unless otherwise noted.
2. Determined according to ANSI/ESDA/JEDEC Standard JS-001-2017, *For Electrostatic Discharge Sensitivity Testing, Human Body Model (HBM) - Component Level*.
3. Determined according to ANSI/ESDA/JEDEC Standard JS-002-2018, *For Electrostatic Discharge Sensitivity Testing, Charged Device Model (CDM) - Device Level*.
4. Determined according to JEDEC Standard JESD78F, *IC Latch-Up Test*.

8.4 Voltage and current operating ratings

Table 6. Voltage and current operating ratings

Symbol	Description	Min.	Max.	Unit
V_{DD}	Digital supply voltage	-0.3	3.8	V
I_{DD}	Digital supply current	—	120	mA
V_{IO}	IO pin input voltage	-0.3	$V_{DD} + 0.3$	V
I_D	Instantaneous maximum current single pin limit (applies to all port pins)	-25	25	mA
V_{DDA}	Analog supply voltage	$V_{DD} - 0.3$	$V_{DD} + 0.3$	V

9 General

9.1 General characteristics

Absolute maximum ratings in the table of "Voltage and current operating ratings" section are stress ratings only, and functional operation at the maximum is not guaranteed. Stress beyond these ratings may affect device reliability or cause permanent damage to the device.

Unless otherwise stated, all specifications within this chapter apply to the temperature range specified in the table of "Voltage and current operating ratings" section over the following supply ranges: $V_{SS} = V_{SSA} = 0$ V, $V_{DD} = V_{DDA} = 3.0$ V to 3.6 V, $CL \leq 50$ pF, $f_{OP} = 50$ MHz.

CAUTION

This device contains protective circuitry to guard against damage due to high static voltage or electrical fields. However, normal precautions are advised to avoid application of any voltages higher than maximum-rated voltages to this high-impedance circuit. Reliability of operation is enhanced if unused inputs are tied to an appropriate voltage level.

9.2 AC electrical characteristics

Tests are conducted using the input levels specified in the section "Voltage and current operating behaviors". Unless otherwise specified, propagation delays are measured from the 50% to the 50% point, and rise and fall times are measured between the 20% and 80% points, as shown in [Figure 5](#).

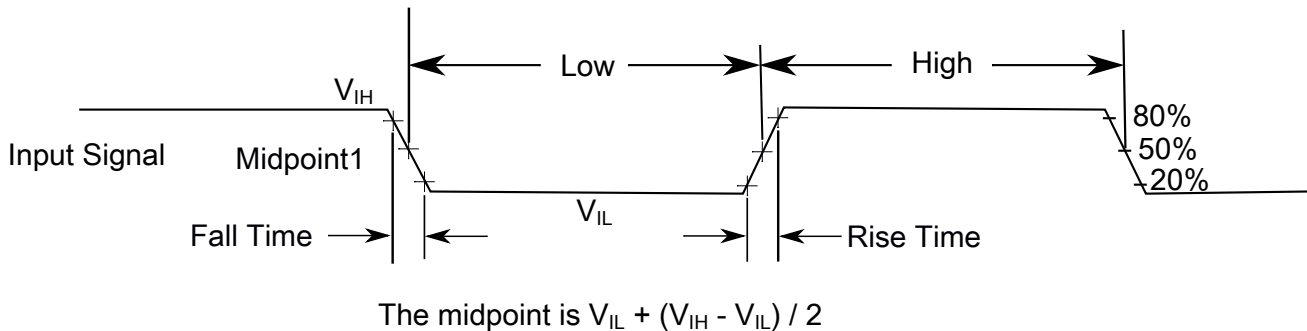

Figure 5. Input signal measurement references

All digital I/O switching characteristics, unless otherwise specified, assume that the output pins have the following characteristics.

- $C_L=30$ pF loads
- Slew rate disabled
- Normal drive strength

[Figure 6](#) shows the definitions of the following signal states:

- Active state, when a bus or signal is driven, and enters a low impedance state
- Tri-stated, when a bus or signal is placed in a high impedance state
- Data Valid state, when a signal level has reached V_{OL} or V_{OH}
- Data Invalid state, when a signal level is in transition between V_{OL} and V_{OH}

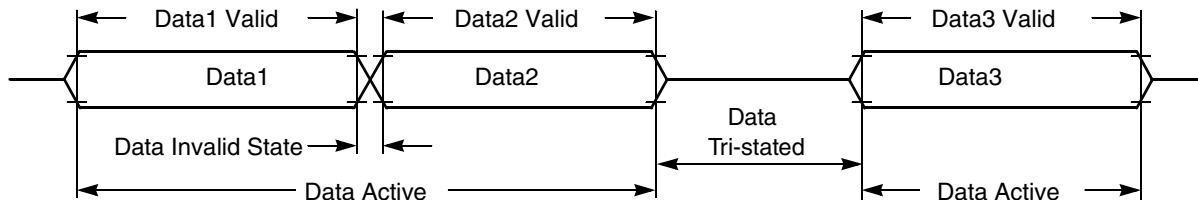

Figure 6. Signal states

9.3 Nonswitching electrical specifications

9.3.1 Voltage and current operating requirements

This section includes information about recommended operating conditions.

Table 7. Voltage and current operating requirements

Symbol	Description	Min.	Typ.	Max.	Unit	Notes
V _{DD}	Supply voltage	2.7	3.3	3.6	V	—
V _{DDA}	Analog supply voltage	2.7	3.3	3.6	V	—
V _{DD} – V _{DDA}	V _{DD} -to-V _{DDA} differential voltage	–0.1		0.1	V	—
V _{SS} – V _{SSA}	V _{SS} -to-V _{SSA} differential voltage	–0.1		0.1	V	—
V _{IH}	Input high voltage • 2.7 V ≤ V _{DD} ≤ 3.6 V	0.7 × V _{DD}		—	V	—
V _{IL}	Input low voltage • 2.7 V ≤ V _{DD} ≤ 3.6 V	—		0.35 × V _{DD}	V	—
V _{HYS}	Input hysteresis	0.06 × V _{DD}		—	V	—
V _{IHOsc}	Oscillator Input Voltage High XTAL driven by an external clock source	2.0		V _{DD} + 0.3	V	—
V _{ILOsc}	Oscillator Input Voltage Low	–0.3		0.8	V	—
I _{ICIO}	IO pin negative DC injection current—single pin • V _{IN} < V _{SS} –0.3V	–3		—	mA	1
I _{ICcont}	Contiguous pin DC injection current —regional limit, includes sum of negative injection currents of 16 contiguous pins • Negative current injection	–25		—	mA	—

1. All I/O pins are internally clamped to V_{SS} through a ESD protection diode. There is no diode connection to V_{DD}. If V_{IN} greater than V_{IO_MIN} (= V_{SS}–0.3 V) is observed, then there is no need to provide current limiting resistors at the pads. If this limit cannot be observed then a current limiting resistor is required. The negative DC injection current limiting resistor is calculated as R = (V_{IO_MIN} - V_{IN})/|I_{ICIO}|.

9.3.2 LVD and POR operating requirements

Table 8. PMC Low-Voltage Detection (LVD) and Power-On Reset (POR) Parameters

Characteristic	Symbol	Min	Typ	Max	Unit
POR Assert Voltage ¹	POR		2.0		V
POR Release Voltage ²	POR		2.7		V
Low-Voltage Warning Interrupt	LVI_2p65		2.65		V
Low-Voltage Alarm Interrupt	LVI_2p2		2.18		V

1. During 3.3-volt V_{DD} power supply ramp down
2. During 3.3-volt V_{DD} power supply ramp up (gated by LVI_2p65)

9.3.3 Voltage and current operating behaviors

Table 9. Voltage and current operating behaviors

Symbol	Description	Min.	Max.	Unit	Notes
V_{OH}	Output high voltage — Normal drive pad (except RESET) • $2.7\text{ V} \leq V_{DD} \leq 3.6\text{ V}$, $I_{OH} = -5\text{ mA}$	$V_{DD} - 0.5$	—	V	1
V_{OH}	Output high voltage — High drive pad (except RESET) • $2.7\text{ V} \leq V_{DD} \leq 3.6\text{ V}$, $I_{OH} = -20\text{ mA}$	$V_{DD} - 0.5$	—	V	2, 1
I_{OHT}	Output high current total for all ports	—	100	mA	—
V_{OL}	Output low voltage — Normal drive pad (except RESET) • $2.7\text{ V} \leq V_{DD} \leq 3.6\text{ V}$, $I_{OL} = 5\text{ mA}$	—	0.5	V	1
V_{OL}	Output low voltage — High drive pad (except RESET) • $2.7\text{ V} \leq V_{DD} \leq 3.6\text{ V}$, $I_{OL} = 20\text{ mA}$	—	0.5	V	2, 1
I_{OLT}	Output low current total for all ports	—	100	mA	—
I_{IN}	Input leakage current (per pin) for full temperature range	—	1	μA	3
I_{IN}	Input leakage current (per pin) at 25 °C	—	0.025	μA	3
I_{IN}	Input leakage current (total all pins) for full temperature range	—	41	μA	3
I_{OZ}	Hi-Z (off-state) leakage current (per pin)	—	1	μA	—
R_{PU}	Internal pullup resistors	20	50	k Ω	4
R_{PD}	Internal pulldown resistors	20	50	k Ω	5

1. The reset pin only contains an active pull down device when configured as the RESET signal or as a GPIO. When configured as a GPIO output, it acts as a pseudo open drain output.
2. GPIOC2, GPIOC7~12, GPIOF2~3 and GPIOC14~15 support high drive strength mode.
3. Measured at $V_{DD} = 3.6\text{ V}$
4. Measured at V_{DD} supply voltage = V_{DD} min and $V_{input} = V_{SS}$
5. Measured at V_{DD} supply voltage = V_{DD} min and $V_{input} = V_{DD}$

9.3.4 Power mode transition operating behaviors

Parameters listed are guaranteed by design.

NOTE

All address and data buses described here are internal.

Table 10. Reset, stop, wait, and interrupt timing

Characteristic	Symbol	Typical Min	Typical Max	Unit	See Figure
Minimum RESET Assertion Duration	t_{RA}	16 ¹	—	ns	—
RESET deassertion to First Address Fetch	t_{RDA}	$865 \times T_{OSC} + 8 \times T$		ns	—
Delay from Interrupt Assertion to Fetch of first instruction (exiting Stop)	t_{IF}	361.3	570.9	ns	—

1. If the RESET pin filter is enabled by setting the RST_FLT bit in the SIM_CTRL register to 1, the minimum pulse assertion must be greater than 21 ns. Recommended a capacitor of up to 0.1 μ F on RESET.

NOTE

In Table 10, T = system clock cycle and T_{OSC} = oscillator clock cycle. For an operating frequency of 50MHz, T=20 ns. At 4 MHz (used coming out of reset and stop modes), T=250 ns.

Table 11. Power mode transition behavior

Symbol	Description	Typical	Max	Unit	Notes ¹
T_{POR}	After a POR event, the amount of delay from when V_{DD} reaches 2.7 V to when the first instruction executes (over the operating temperature range).	300	345	μ s	
	STOP mode to RUN mode	7.30	8.40	μ s	2
	LPS mode to LPRUN mode	290	334	μ s	3
	VLPS mode to VLPRUN mode	900	1035	μ s	4
	WAIT mode to RUN mode	0.305	0.351	μ s	5
	LPWAIT mode to LPRUN mode	290	334	μ s	3
	VLPWAIT mode to VLPRUN mode	900	1035	μ s	4

1. Wakeup times are measured from GPIO toggle for wakeup till GPIO toggle at the wakeup interrupt subroutine from respective stop/wait mode.
2. Clock configuration: CPU clock=4 MHz. System clock source is 8 MHz IRC in normal mode.
3. CPU clock = 200 kHz and 8 MHz IRC on standby. Exit by an interrupt on PORTA GPIO.
4. Using 64 kHz external clock; CPU Clock = 32 kHz. Exit by an interrupt on PORTA GPIO.
5. Clock configuration: CPU and system clocks = 100 MHz. Bus Clock = 100 MHz. Exit by interrupt on PORTA GPIO

9.3.5 Power consumption operating behaviors**Table 12. Current Consumption (Unit: mA)**

Mode	Maximum Frequency	Conditions ¹	Typical at 3.3 V, 25°C		Maximum at 3.6 V, 105°C		Maximum at 3.6V, 125°C	
			I_{DD}^1	I_{DDA}	I_{DD}^1	I_{DDA}	I_{DD}^1	I_{DDA}
RUN	100 MHz	<ul style="list-style-type: none"> • 100 MHz Core and Peripheral clock • Regulators are in full regulation • Relaxation Oscillator on • PLL powered on 	26.9	6.9	32.5	14.2	33.0	14.9

Table continues on the next page...

Table 12. Current Consumption (Unit: mA) (continued)

Mode	Maximum Frequency	Conditions ¹	Typical at 3.3 V, 25°C		Maximum at 3.6 V, 105°C		Maximum at 3.6V, 125°C	
			I _{DD} ¹	I _{DDA}	I _{DD} ¹	I _{DDA}	I _{DD} ¹	I _{DDA}
		<ul style="list-style-type: none"> Continuous MAC instructions with fetches from Program Flash All peripheral modules enabled. SCIs using 1X bus clock NanoEdge within eFlexPWM using 2X peripheral clock ADC/DAC (all 8-bit DACs) powered on and clocked Comparator powered on 						
WAIT	100 MHz	<ul style="list-style-type: none"> 50 MHz Core and Peripheral clock Regulators are in full regulation Relaxation Oscillator on PLL powered on Processor Core in WAIT state All Peripheral modules enabled. SCIs using 1X bus clock NanoEdge within PWMA using 2X peripheral clock ADC/DAC (all 8-bit DACs), Comparator powered off 	21.2	0.033	28.4	0.193 ²	28.9	0.193 ²
STOP	4 MHz	<ul style="list-style-type: none"> 4 MHz Device Clock Regulators are in full regulation Relaxation Oscillator on PLL powered off Processor Core in STOP state All peripheral module and core clocks are off ADC/DAC/Comparator powered off 	4.4	0.033	9.0	0.192 ²	9.5	0.192 ²
LPRUN (LsRUN)	2 MHz	<ul style="list-style-type: none"> 200 kHz Device Clock from Relaxation Oscillator's (ROSC) low speed clock ROSC in standby mode Regulators are in standby PLL disabled Repeat NOP instructions All peripheral modules enabled, except NanoEdge and cyclic ADCs. All 8-bit DACs enabled. ³ Simple loop with running from platform instruction buffer 	1.1	0.002	5.2	0.066 ²	5.7	0.066 ²
LPWAIT (LsWAIT)	2 MHz	<ul style="list-style-type: none"> 200 kHz Device Clock from Relaxation Oscillator's (ROSC) low speed clock ROSC in standby mode Regulators are in standby PLL disabled All peripheral modules enabled, except NanoEdge and cyclic ADCs. All 8-bit DACs enabled. ³ Processor core in wait mode 	1.0	0.002	5.2	0.065 ²	5.7	0.065 ²
LPSTOP (LsSTOP)	2 MHz	<ul style="list-style-type: none"> 200 kHz Device Clock from Relaxation Oscillator's (ROSC) low speed clock ROSC in standby mode Regulators are in standby 	1.0	0.002	4.2	0.065 ²	4.5	0.065 ²

Table continues on the next page...

Table 12. Current Consumption (Unit: mA) (continued)

Mode	Maximum Frequency	Conditions ¹	Typical at 3.3 V, 25°C		Maximum at 3.6 V, 105°C		Maximum at 3.6V, 125°C	
			I _{DD} ¹	I _{DDA}	I _{DD} ¹	I _{DDA}	I _{DD} ¹	I _{DDA}
		<ul style="list-style-type: none"> • PLL disabled • Only PITs and COP enabled; other peripheral modules disabled and clocks gated off³ • Processor core in stop mode 						
VLPRUN	200 kHz	<ul style="list-style-type: none"> • 32 kHz Device Clock • Clocked by a 64 kHz external clock source • Oscillator in power down • All ROSCs disabled • Large regulator is in standby • Small regulator is disabled • PLL disabled • Repeat NOP instructions • All peripheral modules, except COP and EWM, disabled and clocks gated off • Simple loop running from platform instruction buffer 	0.4	0.002	4.0	0.065 ²	4.3	0.065 ²
VLPWAIT	200 kHz	<ul style="list-style-type: none"> • 32 kHz Device Clock • Clocked by a 64 kHz external clock source • Oscillator in power down • All ROSCs disabled • Large regulator is in standby • Small regulator is disabled • PLL disabled • All peripheral modules, except COP, disabled and clocks gated off • Processor core in wait mode 	0.4	0.002	4.0	0.064 ²	4.3	0.064 ²
VLPSTOP	200 kHz	<ul style="list-style-type: none"> • 32 kHz Device Clock • Clocked by a 64 kHz external clock source • Oscillator in power down • All ROSCs disabled • Large regulator is in standby. • Small regulator is disabled. • PLL disabled • All peripheral modules, except COP, disabled and clocks gated off • Processor core in stop mode 	0.4	0.002	4.0	0.062 ²	4.3	0.062 ²

1. No output switching, all ports configured as inputs, all inputs low, no DC loads.
2. Parameter value is achieved by design characterization by measuring a statistically relevant sample size across process variations.
3. In all chip LP modes and flash memory VLP modes, the maximum frequency for flash memory operation is 250 kHz due to the fixed frequency ratio of 1:4 between the CPU clock and the flash clock when running with 2 MHz external clock input and CPU running at 1 MHz.

9.3.6 Designing with radiated emissions in mind

To find application notes that provide guidance on designing your system to minimize interference from radiated emissions:

1. Go to www.nxp.com.

2. Perform a keyword search for “EMC design.”

9.3.7 Capacitance attributes

Table 13. Capacitance attributes

Description	Symbol	Min.	Typ.	Max.	Unit
Input capacitance	C_{IN}	—	10	—	pF
Output capacitance	C_{OUT}	—	10	—	pF

9.4 Switching specifications

9.4.1 Device clock specifications

Table 14. Device clock specifications

Symbol	Description	Min.	Max.	Unit	Notes
Normal run mode					
f_{SYSCLK}	Device (system and core) clock frequency <ul style="list-style-type: none"> • using relaxation oscillator • using external clock source 	0.001 0	100 100	MHz	
f_{BUS}	Bus clock	—	50	MHz	

9.4.2 General switching specifications

These general-purpose specifications apply to all signals configured for GPIO signals.

Table 15. General switching specifications

Description	Min.	Max.	Unit	Notes
GPIO pin interrupt pulse width (digital glitch filter disabled) — Synchronous path	1.5	—	Bus clock cycles	1
External RESET and NMI pin interrupt pulse width — Asynchronous path	100	—	ns	2
GPIO pin interrupt pulse width — Asynchronous path	16	—	ns	2
Port rise and fall time	—	36	ns	3

1. The synchronous and asynchronous timing must be met.
2. This is the shortest pulse that is guaranteed to be recognized.
3. 75 pF load

9.5 Thermal specifications

9.5.1 Thermal operating requirements

Table 16. Thermal operating requirements

Symbol	Description	Grade	Min	Max	Unit
T_J	Die junction temperature	V	-40	125	°C
		M	-40	135	°C
T_A	Ambient temperature	V	-40	105	°C
		M	-40	125	°C

9.5.2 Thermal attributes

This section provides information about operating temperature range, power dissipation, and package thermal resistance. Power dissipation on I/O pins is usually small compared to the power dissipation in on-chip logic and voltage regulator circuits, and it is user-determined rather than being controlled by the MCU design. To account for $P_{I/O}$ in power calculations, determine the difference between actual pin voltage and V_{SS} or V_{DD} and multiply by the pin current for each I/O pin. Except in cases of unusually high pin current (heavy loads), the difference between pin voltage and V_{SS} or V_{DD} is very small.

See [Thermal design considerations](#) for more detail on thermal design considerations.

Board type ¹	Symbol	Description	48 LQFP	64 LQFP	Unit	Notes
Four-layer (2s2p)	$R_{\theta JA}$	Thermal resistance, junction to ambient (natural convection)	55	52	°C/W	2
Single-layer (1s)	$R_{\theta JC}$	Thermal resistance, junction to case	23	20	°C/W	3
—	Ψ_{JT}	Thermal characterization parameter, junction to package top outside center (natural convection)	3	3	°C/W	2

1. Thermal test board meets JEDEC specification for this package (JESD51-7, 2s2p and JESD51-3, 1s).

- Determined in accordance to JEDEC JESD51-2A natural convection environment. Thermal resistance data in this report is solely for a thermal performance comparison of one package to another in a standardized specified environment. It is not meant to predict the performance of a package in an application-specific environment.
- Junction-to-Case (Top) thermal resistance is determined using an isothermal cold plate attached to the package top. Case (Top) temperature refers to the mold surface temperature at the center.

10 Peripheral operating requirements and behaviors

10.1 Core modules

10.1.1 JTAG timing

Table 17. JTAG timing

Characteristic	Symbol	Min	Max	Unit	See Figure
TCK frequency of operation	f_{OP}	DC	SYS_CLK/ 8	MHz	Figure 7
TCK clock pulse width	t_{PW}	50	—	ns	Figure 7
TMS, TDI data set-up time	t_{DS}	5	—	ns	Figure 8
TMS, TDI data hold time	t_{DH}	5	—	ns	Figure 8
TCK low to TDO data valid	t_{DV}	—	30	ns	Figure 8
TCK low to TDO tri-state	t_{TS}	—	30	ns	Figure 8

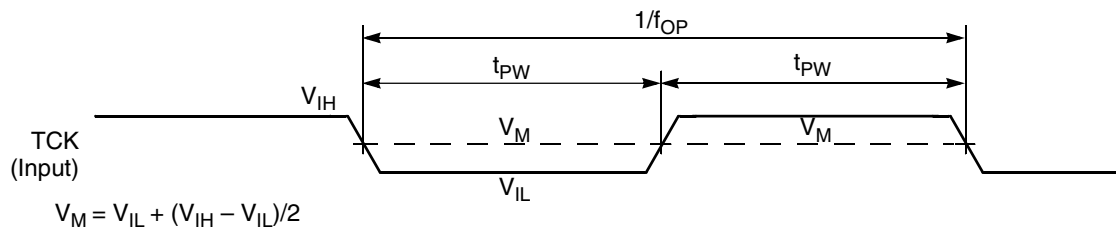

Figure 7. Test clock input timing diagram

System modules

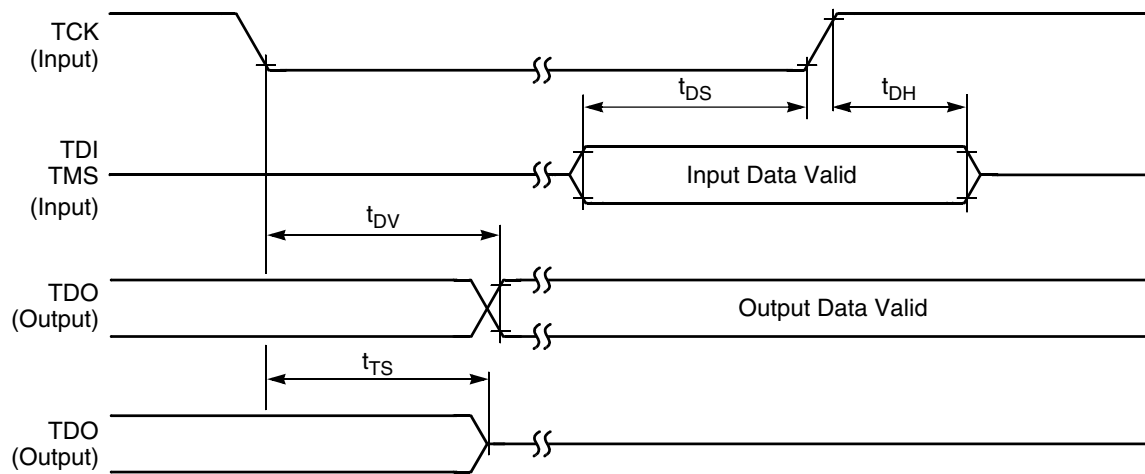

Figure 8. Test access port timing diagram

10.2 System modules

10.2.1 Voltage regulator specifications

The voltage regulator supplies approximately 1.2 V to the device's core logic. For proper operations, the voltage regulator requires a minimum external 2.2 μF capacitor on each V_{CAP} pin with total capacitors on all V_{CAP} pins at a minimum of 4.4 μF . Ceramic and tantalum capacitors tend to provide better performance tolerances. The output voltage can be measured directly on the V_{CAP} pin. The specifications for this regulator are shown in [Table 18](#).

Table 18. Regulator 1.2 V parameters

Characteristic	Symbol	Min	Typ	Max	Unit
Output Voltage ¹	V_{CAP}	—	1.26	—	V
Short Circuit Current ²	I_{SS}	—	600	—	mA
Short Circuit Tolerance (V_{CAP} shorted to ground)	T_{RSC}	—	—	1	minute

1. Value is after trim

2. Guaranteed by design

Table 19. Bandgap electrical specifications

Characteristic	Symbol	Min	Typ	Max	Unit
Reference Voltage (after trim)	V_{REF}	—	1.22 ¹	—	V

1. Typical value is trimmed at 25°C. There could be ± 50 mV variation due to temperature change.

10.3 Clock modules

10.3.1 External clock operation timing

Parameters listed are guaranteed by design.

Table 20. External clock operation timing requirements

Characteristic	Symbol	Min	Typ	Max	Unit
Frequency of operation (external clock driver) ¹	f_{osc}	—	—	50	MHz
Clock pulse width ²	t_{PW}	8			ns
External clock input rise time ³	t_{rise}	—	1.9	2.5	ns
External clock input fall time ⁴	t_{fall}	—	1.9	2.5	ns
Input high voltage overdrive by an external clock	V_{ih}	$0.85 \times V_{DD}$	—	—	V
Input low voltage overdrive by an external clock	V_{il}	—	—	$0.3 \times V_{DD}$	V

1. See the "External clock timing" figure for details on using the recommended connection of an external clock driver.
2. The chip may not function if the high or low pulse width is smaller than 6.25 ns.
3. External clock input rise time is measured from 10% to 90%.
4. External clock input fall time is measured from 90% to 10%.

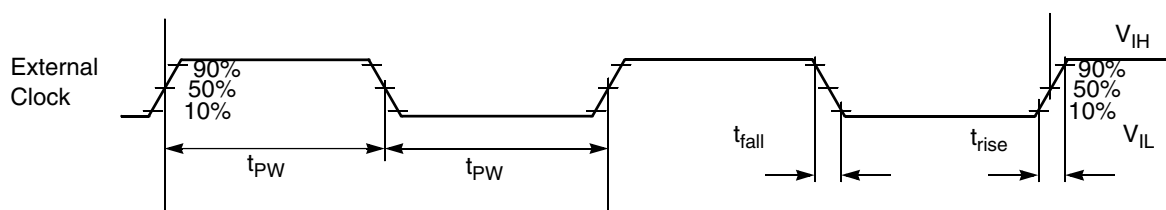

Note: The midpoint is $V_{IL} + (V_{IH} - V_{IL})/2$.

Figure 9. External clock timing

10.3.2 Phase-Locked Loop timing

Table 21. Phase-Locked Loop timing

Characteristic	Symbol	Min	Typ	Max	Unit
PLL input reference frequency ¹	f_{ref}	8	8	16	MHz
PLL output frequency ²	f_{op}	200	—	550	MHz
PLL lock time ³	t_{pils}	—	—	100	μs
Allowed Duty Cycle of input reference	t_{dc}	40	50	60	%

1. An externally supplied reference clock should be as free as possible from any phase jitter for the PLL to work correctly. The PLL is designed for 8 MHz ~ 16 MHz input, but optimized for 8 MHz input.
2. The frequency of the core system clock cannot exceed 100 MHz. If the NanoEdge PWM is available, the PLL output must be set to 400 MHz.
3. This is the time required *after the PLL is enabled* to ensure reliable operation.

10.3.3 External crystal or resonator requirement

Table 22. Crystal or resonator requirement

Characteristic	Symbol	Min	Typ	Max	Unit
Frequency of operation	f_{XOSC}	4	8	16	MHz

10.3.4 RC Oscillator Timing

Table 23. RC Oscillator Electrical Specifications

Characteristic		Symbol	Min	Typ	Max	Unit
8 MHz Output Frequency ¹						
Run Mode	0°C to 105°C		7.84	8	8.16	MHz
	-40°C to 105°C		7.76	8	8.24	MHz
	-40°C to 125°C		7.76	8	8.24	MHz
2M Mode (IRC trimmed @ 8 MHz)	-40°C to 105°C		1.9	2.0	2.1	MHz
	-40°C to 125°C		1.9	2.0	2.1	MHz
8 MHz Frequency Variation over 25°C						
RUN Mode	0°C to 105°C			±1.5	±2	%
	-40°C to 105°C			±1.5	±3	%
	-40°C to 125°C			±1.5	-3 to +3	%
200 kHz Output Frequency ²						
RUN Mode	-40°C to 105°C		194	200	206	kHz
	-40°C to 125°C		192	200	208	kHz
200 kHz Output Frequency Variation over 25°C						
RUN Mode	0°C to 85°C			±1.5	±2	%
	-40°C to 105°C			±1.5	±3	%
	-40°C to 125°C			±1.5	±4	%
Stabilization Time	8 MHz output ³	tstab	1	-	15	µs
	200 kHz output ³		-	125	375	µs
Output Duty Cycle			45	50	55	%

1. Frequency after factory trim
2. Frequency after factory trim
3. Power down to run mode transition

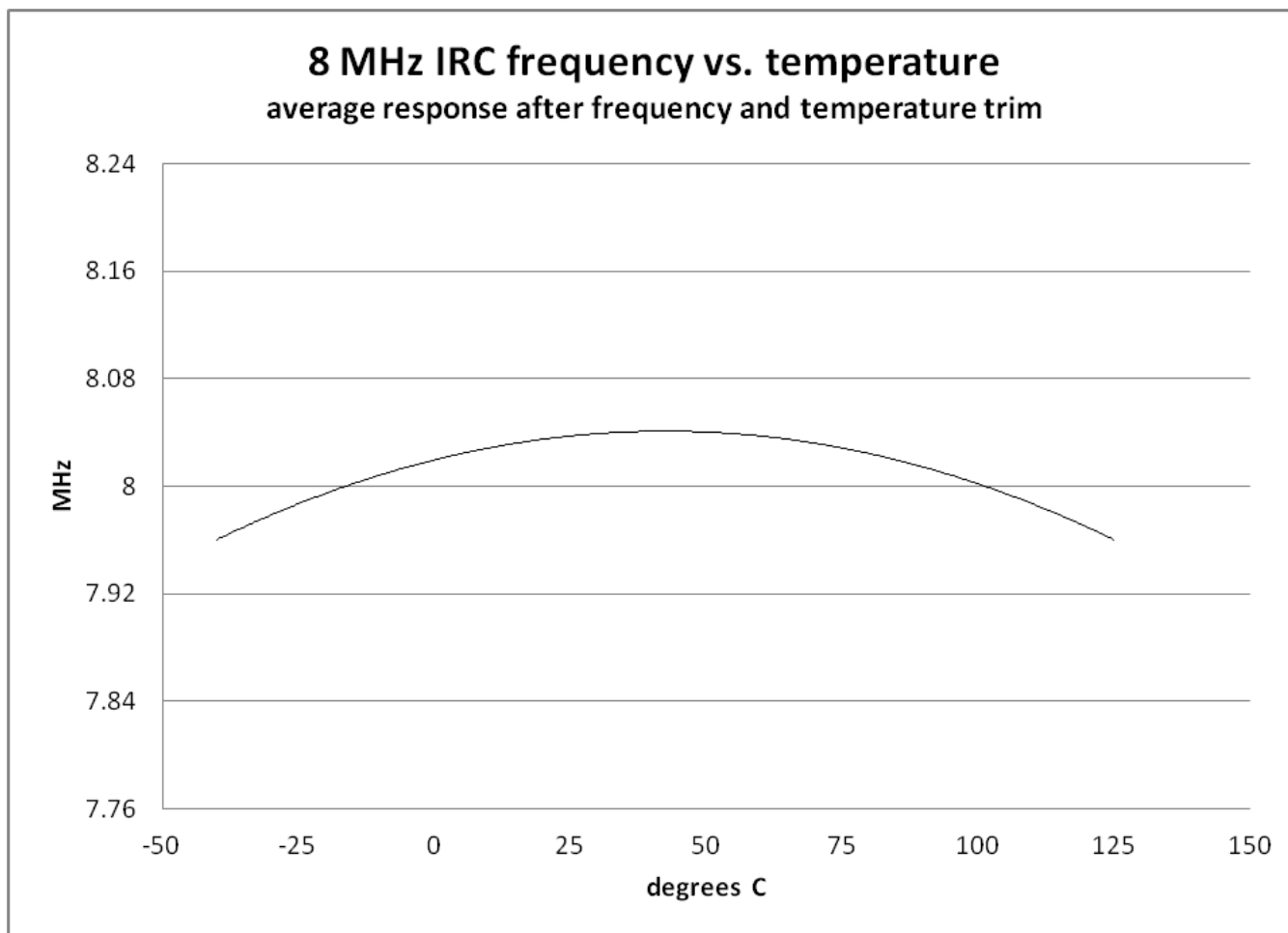

Figure 10. RC Oscillator Temperature Variation (Typical) After Trim (Preliminary)

10.4 Memories and memory interfaces

10.4.1 Flash electrical specifications

This section describes the electrical characteristics of the flash memory module.

10.4.1.1 Flash timing specifications — program and erase

The following specifications represent the amount of time the internal charge pumps are active and do not include command overhead.

Table 24. NVM program/erase timing specifications

Symbol	Description	Min.	Typ.	Max.	Unit	Notes
t_{hvpgm4}	Longword Program high-voltage time	—	7.5	18	μ s	—

Table continues on the next page...

Table 24. NVM program/erase timing specifications (continued)

Symbol	Description	Min.	Typ.	Max.	Unit	Notes
$t_{hversscr}$	Sector Erase high-voltage time	—	13	113	ms	1
$t_{hversall}$	Erase All high-voltage time	—	52	452	ms	1

1. Maximum time based on expectations at cycling end-of-life.

10.4.1.2 Flash timing specifications — commands

Table 25. Flash command timing specifications

Symbol	Description	Min.	Typ.	Max.	Unit	Notes
$t_{rd1sec1k}$	Read 1s Section execution time (flash sector)	—	—	60	μ s	1
t_{pgmchk}	Program Check execution time	—	—	45	μ s	1
t_{rdsrc}	Read Resource execution time	—	—	30	μ s	1
t_{pgm4}	Program Longword execution time	—	65	145	μ s	—
t_{ersscr}	Erase Flash Sector execution time	—	14	114	ms	2
t_{rd1all}	Read 1s All Blocks execution time	—	—	1.8	ms	1
t_{rdonce}	Read Once execution time	—	—	25	μ s	1
$t_{pgmonce}$	Program Once execution time	—	65	—	μ s	—
t_{ersall}	Erase All Blocks execution time	—	88	650	ms	2
t_{vfykey}	Verify Backdoor Access Key execution time	—	—	30	μ s	1
$t_{ersallu}$	Erase All Blocks Unsecure execution time	—	88	650	ms	2

1. Assumes 25 MHz flash clock frequency.

2. Maximum times for erase parameters based on expectations at cycling end-of-life.

10.4.1.3 Flash high voltage current behaviors

Table 26. Flash high voltage current behaviors

Symbol	Description	Min.	Typ.	Max.	Unit
I_{DD_PGM}	Average current adder during high voltage flash programming operation	—	2.5	6.0	mA
I_{DD_ERS}	Average current adder during high voltage flash erase operation	—	1.5	4.0	mA

10.4.1.4 Reliability specifications

Table 27. NVM reliability specifications

Symbol	Description	Min.	Typ. ¹	Max.	Unit	Notes
Program Flash						
$t_{nmretp10k}$	Data retention after up to 10 K cycles	5	50	—	years	—
$t_{nmretp1k}$	Data retention after up to 1 K cycles	20	100	—	years	—

Table continues on the next page...

Table 27. NVM reliability specifications (continued)

Symbol	Description	Min.	Typ. ¹	Max.	Unit	Notes
$n_{nvmcycp}$	Cycling endurance	10 K	50 K	—	cycles	2
$n_{nvmcycp}$	Cycling endurance	1 K	—	—	cycles	3

1. Typical data retention values are based on measured response accelerated at high temperature and derated to a constant 25 °C use profile. Engineering Bulletin EB618 does not apply to this technology. Typical endurance defined in Engineering Bulletin EB619.
2. Cycling endurance represents number of program/erase cycles at $-40\text{ °C} \leq T_j \leq 125\text{ °C}$.
3. Cycling endurance represents number of program/erase cycles at $-40\text{ °C} \leq T_j \leq 135\text{ °C}$. If the product application is exposed to $T_j > 125\text{ °C}$, the reduced W/E spec applies independent of the number of W/E cycles in the high T_j band.

10.5 Analog

10.5.1 12-bit Cyclic Analog-to-Digital Converter (ADC) Parameters

Table 28. 12-bit ADC Electrical Specifications

Characteristic	Symbol	Min	Typ	Max	Unit
Recommended Operating Conditions					
Supply Voltage ¹	VDDA	3	3.3	3.6	V
VREFH (in external reference mode)	Vrefhx	VDDA-0.6		VDDA	V
ADC Conversion Clock ²	f_{ADCCLK}	0.1		12.5	MHz
Conversion Range ³	R_{AD}			$V_{REFH} - V_{REFL}$	V
Fully Differential		$-(V_{REFH} - V_{REFL})$		V_{REFH}	
Single Ended/Unipolar		V_{REFL}			
Input Voltage Range (per input) ⁴	V_{ADIN}	V_{REFL}		V_{REFH}	V
External Reference		0		V_{DDA}	
Internal Reference					
Timing and Power					
Conversion Time ⁵	t_{ADC}		8		ADC Clock Cycles
ADC Power-Up Time (from adc_pdn)	t_{ADPU}		13		ADC Clock Cycles
ADC RUN Current (per ADC block)	I_{ADRUN}		2.5		mA
ADC Powerdown Current (adc_pdn enabled)	$I_{ADPWRDWN}$		0.1		μ A
V_{REFH} Current (in external mode)	I_{VREFH}		190	225	μ A
Accuracy (DC or Absolute)					
Integral non-Linearity ⁶	INL		+/- 1.5	+/- 2.2	LSB ⁷
Differential non-Linearity ⁶	DNL		+/- 0.5	+/- 0.8	LSB ⁷
Monotonicity			GUARANTEED		
Offset ⁸	V_{OFFSET}				mV

Table continues on the next page...

Table 28. 12-bit ADC Electrical Specifications (continued)

Characteristic	Symbol	Min	Typ	Max	Unit
Fully Differential			+/- 8		
Single Ended/Unipolar			+/- 12		
Gain Error	E_{GAIN}		0.996 to 1.004	0.990 to 1.010	
AC Specifications⁹					
Signal to Noise Ratio	SNR		66		dB
Total Harmonic Distortion	THD		75		dB
Spurious Free Dynamic Range	SFDR		77		dB
Signal to Noise plus Distortion	SINAD		66		dB
Effective Number of Bits	ENOB		—		bits
Gain = 1x (Fully Differential/Unipolar)			10.6		
Gain = 2x (Fully Differential/Unipolar)			—		
Gain = 4x (Fully Differential/Unipolar)			10.3		
Gain = 1x (Single Ended)			10.6		
Gain = 2x (Single Ended)			10.4		
Gain = 4x (Single Ended)			10.2		
Variation across channels ¹⁰			0.1		
ADC Inputs					
Input Leakage Current	I_{IN}		1		nA
Temperature sensor slope	T_{SLOPE}		1.3		mV/°C
Temperature sensor voltage at 25 °C	V_{TEMP25}		0.82		V
Disturbance					
Input Injection Current ¹¹	I_{INJ}			+/-3	mA
Channel to Channel Crosstalk ¹²	ISOXTLK		-82		dB
Memory Crosstalk ¹³	MEMXTLK		-71		dB
Input Capacitance	C_{ADI}		4.8		pF
Sampling Capacitor					

1. The ADC functions up to $V_{DDA} = 2.7$ V. When V_{DDA} is below 3.0 V, ADC specifications are not guaranteed
2. ADC clock duty cycle is 45% ~ 55%
3. Conversion range is defined for x1 gain setting. For x2 and x4 the range is 1/2 and 1/4, respectively.
4. In unipolar mode, positive input must be ensured to be always greater than negative input.
5. First conversion takes 10 clock cycles.
6. INL/DNL is measured from $V_{IN} = V_{REFL}$ to $V_{IN} = V_{REFH}$ using Histogram method at x1 gain setting
7. Least Significant Bit = 0.806 mV at 3.3 V V_{DDA} , x1 gain Setting
8. Offset measured at 2048 code
9. Measured converting a 1 kHz input full scale sine wave
10. When code runs from internal RAM
11. The current that can be injected into or sourced from an unselected ADC input without affecting the performance of the ADC
12. Any off-channel with 50 kHz full-scale input to the channel being sampled with DC input (isolation crosstalk)
13. From a previously sampled channel with 50 kHz full-scale input to the channel being sampled with DC input (memory crosstalk).

10.5.1.1 Equivalent circuit for ADC inputs

The following figure shows the ADC input circuit during sample and hold. S1 and S2 are always opened/closed at non-overlapping phases, and both S1 and S2 are dependent on the ADC clock frequency. The following equation gives equivalent input impedance when the input is selected.

$$\frac{1}{(\text{ADC ClockRate}) \times C_{\text{AdI}}} + 50 \text{ ohm} + \text{Resistor}$$

NOTE

Resistor=1200 ohm@gain1x, or 730 ohm@gain2x, or 500 ohm@gain4x

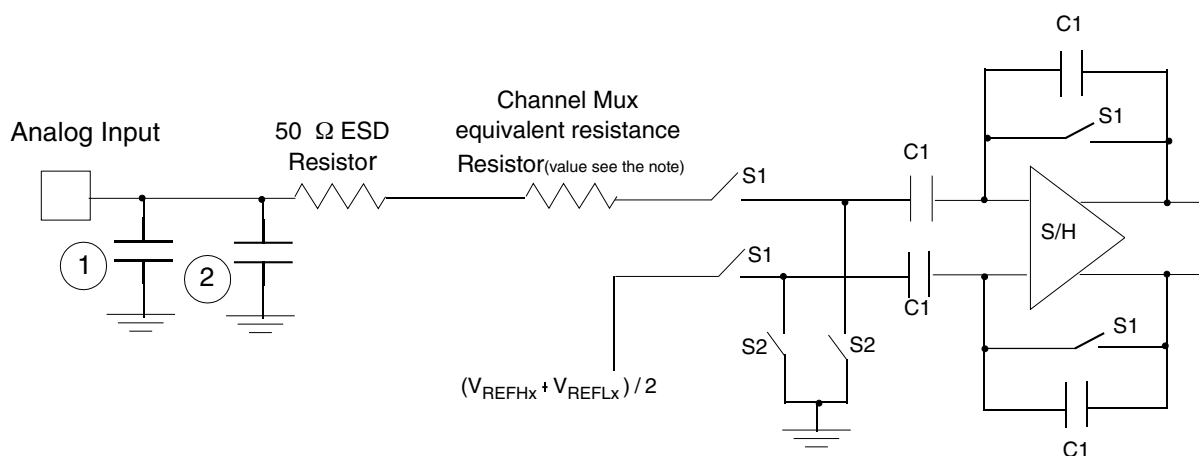

1. Parasitic capacitance due to package, pin-to-pin and pin-to-package base coupling = 1.8pF
2. Parasitic capacitance due to the chip bond pad, ESD protection devices and signal routing = 2.04pF
3. S1 and S2 switch phases are non-overlapping and depend on the ADC clock frequency

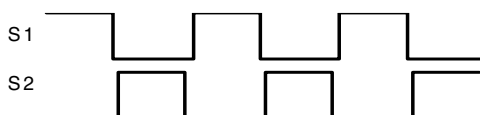

Figure 11. Equivalent circuit for A/D loading

10.5.2 OPAMP electrical specifications

Table 29. OPAMP electrical specifications

Symbol	Description	Min.	Typ.	Max.	Unit
V _{CC}	Power supply	3.0	—	3.6	V
I _{CC}	Supply current <ul style="list-style-type: none"> high-speed mode low-power mode 	—	500	—	μA
V _{OS}	Input offset voltage <ul style="list-style-type: none"> high-speed mode low-power mode 	—	±1.5	±5	mV
V _{IN}	Common input voltage	V _{SSA}	—	V _{DDA} - 1.2	V
V _{OUT}	Output voltage range	0.15	—	V _{DDA} - 0.15	V
CMRR	Input common mode rejection ratio	60	80	—	dB
PSRR	Power supply rejection ratio	60	80	—	dB
SR	Slew rate ¹ <ul style="list-style-type: none"> high-speed mode low-power mode 	4	8	—	V/μs
GBW	Unity gain bandwidth ¹ <ul style="list-style-type: none"> high-speed mode low-power mode 	—	8	—	MHz

1. R_L = 5 ~ 10 kΩ, C_L = 30 ~ 50 pf

10.5.3 CMP and 8-bit DAC electrical specifications

Table 30. Comparator and 8-bit DAC electrical specifications

Symbol	Description	Min.	Typ.	Max.	Unit
V _{DD}	Supply voltage	3.0	—	3.6	V
I _{DDHS}	Supply current, high-speed mode (EN=1, PMODE=1)	—	300	—	μA
I _{DDL}	Supply current, low-speed mode (EN=1, PMODE=0)	—	36	—	μA
V _{Ain}	Analog input voltage	V _{SS}	—	V _{DD}	V
V _{AIO}	Analog input offset voltage ¹	—	—	20	mV
V _H	Analog comparator hysteresis <ul style="list-style-type: none"> CR0[HYSTCTR] = 00² CR0[HYSTCTR] = 01¹ CR0[HYSTCTR] = 10¹ CR0[HYSTCTR] = 11¹ 	—	5	13	mV
V _{CMPOH}	Output high	V _{DD} - 0.5	—	—	V
V _{CMPOI}	Output low	—	—	0.5	V
t _{DHS}	Propagation delay, high-speed mode (EN=1, PMODE=1) ³	—	25	70	ns
t _{DLS}	Propagation delay, low-speed mode (EN=1, PMODE=0) ³	—	60	200	ns
	Analog comparator initialization delay ⁴	—	40	—	μs

Table continues on the next page...

Table 30. Comparator and 8-bit DAC electrical specifications (continued)

Symbol	Description	Min.	Typ.	Max.	Unit
I_{DAC8b}	8-bit DAC current adder (enabled)	—	7	—	μA
$V_{\text{reference}}$	8-bit DAC reference inputs, V_{in1} and V_{in2} There are two reference input options selectable (via VRSEL control bit). The reference options must fall within this range.	—	V_{DD}	—	V
INL	8-bit DAC integral non-linearity	-1	—	1	LSB ⁵
DNL	8-bit DAC differential non-linearity	-1	—	1	LSB

1. Measured with input voltage range limited to $0.7 \leq V_{in} \leq V_{DD} - 0.8$
2. Measured with input voltage range limited to 0 to V_{DD}
3. Input voltage range: $0.1V_{DD} \leq V_{in} \leq 0.9V_{DD}$, step = $\pm 100\text{mV}$, across all temperature. Does not include PCB and PAD delay.
4. Comparator initialization delay is defined as the time of switching the comparator from the disabled state to the enabled state, with the comparator output settling to a stable level.
5. $1 \text{ LSB} = V_{\text{reference}}/256$

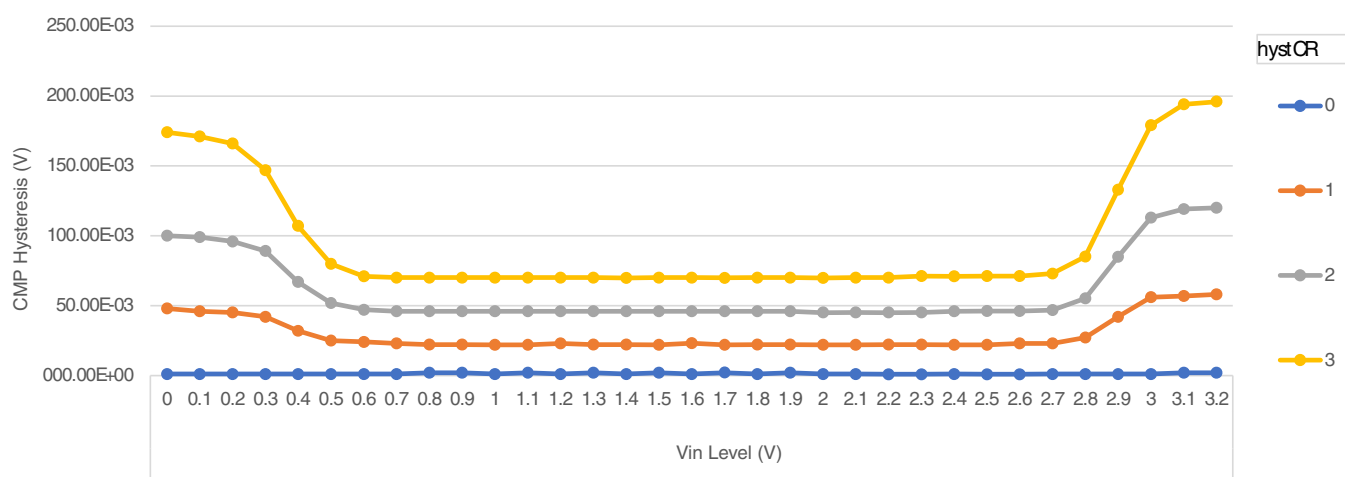
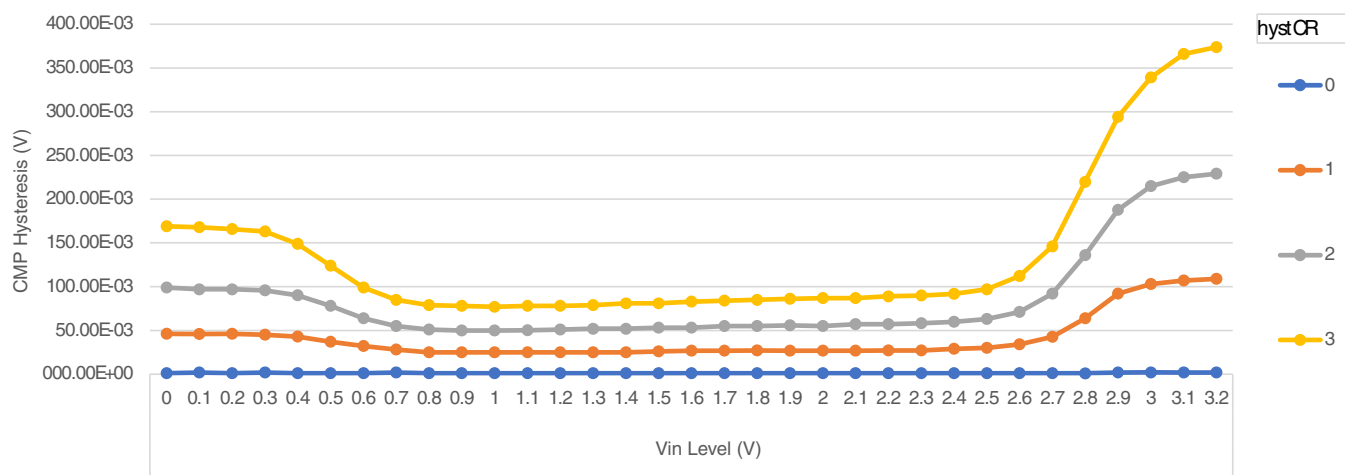
**Figure 12. Typical hysteresis vs. V_{in} level ($V_{DD} = 3.3 \text{ V}$, $\text{PMODE} = 0$)****Figure 13. Typical hysteresis vs. V_{in} level ($V_{DD} = 3.3 \text{ V}$, $\text{PMODE} = 1$)**

10.6 PWMs and timers

10.6.1 Enhanced NanoEdge PWM characteristics

Table 31. NanoEdge PWM timing parameters

Characteristic	Symbol	Min	Typ	Max	Unit
PWM clock frequency			100		MHz
NanoEdge Placement (NEP) Step Size ^{1, 2}	pwmp		312		ps
Delay for fault input activating to PWM output deactivated		1		33	ns
Power-up Time ³	t_{pu}		25		μ s
Resolution of Deadtime			312		ps

1. Reference IPbus clock of 100 MHz in NanoEdge Placement mode.
2. Temperature and voltage variations do not affect NanoEdge Placement step size.
3. Powerdown to NanoEdge mode transition.

10.6.2 Quad Timer timing

Parameters listed are guaranteed by design.

Table 32. Timer timing

Characteristic	Symbol	Min ¹	Max	Unit	See Figure
Timer input period	P_{IN}	$2T + 6$	—	ns	Figure 14
Timer input high/low period	P_{INHL}	$1T + 3$	—	ns	Figure 14
Timer output period	P_{OUT}	20	—	ns	Figure 14
Timer output high/low period	P_{OUTHL}	10	—	ns	Figure 14

1. T = clock cycle. For 100 MHz operation, $T = 10$ ns.

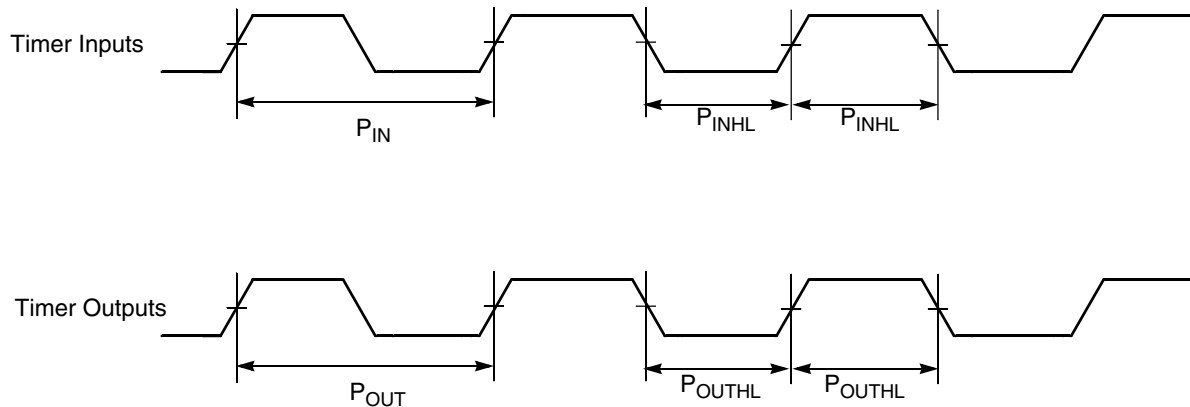

Figure 14. Timer timing

10.6.3 QDC Timing Specifications

Parameters listed are guaranteed by design.

Table 33. Quadrature Decoder Timing

Characteristic	Symbol	Min ¹	Max	Unit
Quadrature input period	P_{IN}	$4T + 12$	—	ns
Quadrature input high/low period	P_{HL}	$2T + 6$	—	ns
Quadrature phase period	P_{PH}	$1T + 3$	—	ns

1. In the formulas listed, T equals the system clock cycle. For 50 MHz operation, T = 20 ns. For 100 MHz operation, T = 10 ns.

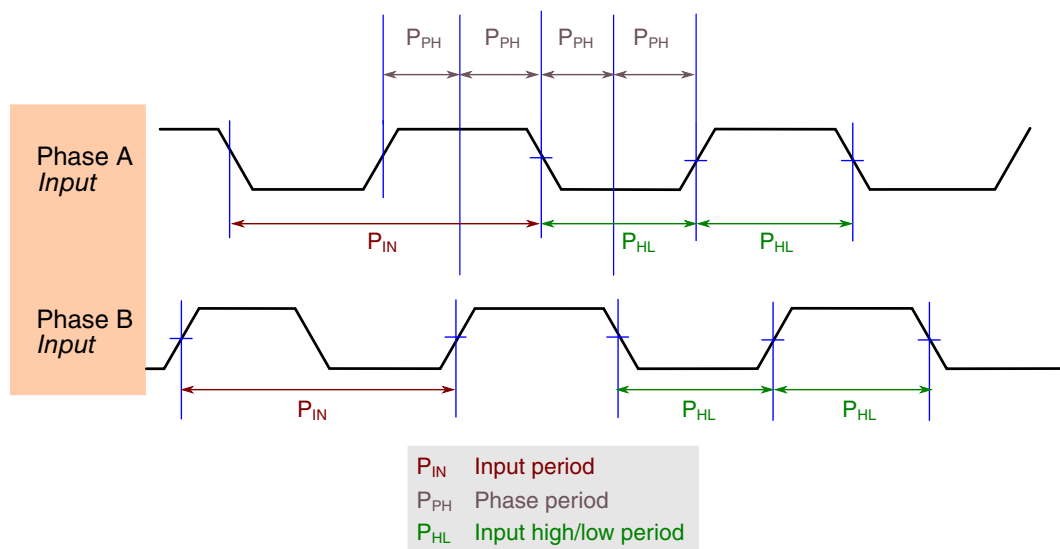

Figure 15. Quadrature Decoder Timing

10.7 Communication interfaces

10.7.1 Queued Serial Peripheral Interface (SPI) timing

Parameters listed are guaranteed by design.

Table 34. SPI timing

Characteristic	Symbol	Min	Max	Unit	See Figure
Cycle time	t_c	60	—	ns	Figure 16

Table continues on the next page...

Table 34. SPI timing (continued)

Characteristic	Symbol	Min	Max	Unit	See Figure
Master		60	—	ns	Figure 17
Slave					Figure 18 Figure 19
Enable lead time	t_{ELD}	—	—	ns	Figure 19
Master		20	—	ns	
Slave					
Enable lag time	t_{ELG}	—	—	ns	Figure 19
Master		20	—	ns	
Slave					
Clock (SCK) high time	t_{CH}		—	ns	Figure 16
Master			—	ns	Figure 17
Slave					Figure 18 Figure 19
Clock (SCK) low time	t_{CL}	28	—	ns	Figure 19
Master		28	—	ns	
Slave					
Data set-up time required for inputs	t_{DS}	20	—	ns	Figure 16
Master		1	—	ns	Figure 17
Slave					Figure 18 Figure 19
Data hold time required for inputs	t_{DH}	1	—	ns	Figure 16
Master		3	—	ns	Figure 17
Slave					Figure 18 Figure 19
Access time (time to data active from high-impedance state)	t_A	5	—	ns	Figure 19
Slave					
Disable time (hold time to high-impedance state)	t_D	5	—	ns	Figure 19
Slave					
Data valid for outputs	t_{DV}	—		ns	Figure 16
Master		—		ns	Figure 17
Slave (after enable edge)					Figure 18 Figure 19
Data invalid	t_{DI}	0	—	ns	Figure 16
Master		0	—	ns	Figure 17
Slave					Figure 18 Figure 19
Rise time	t_R				Figure 16

Table continues on the next page...

Table 34. SPI timing (continued)

Characteristic	Symbol	Min	Max	Unit	See Figure
Master		—	1	ns	Figure 17
Slave		—	1	ns	Figure 18
Fall time	t_F	—	1	ns	Figure 16
Master		—	1	ns	Figure 17
Slave					Figure 18
					Figure 19

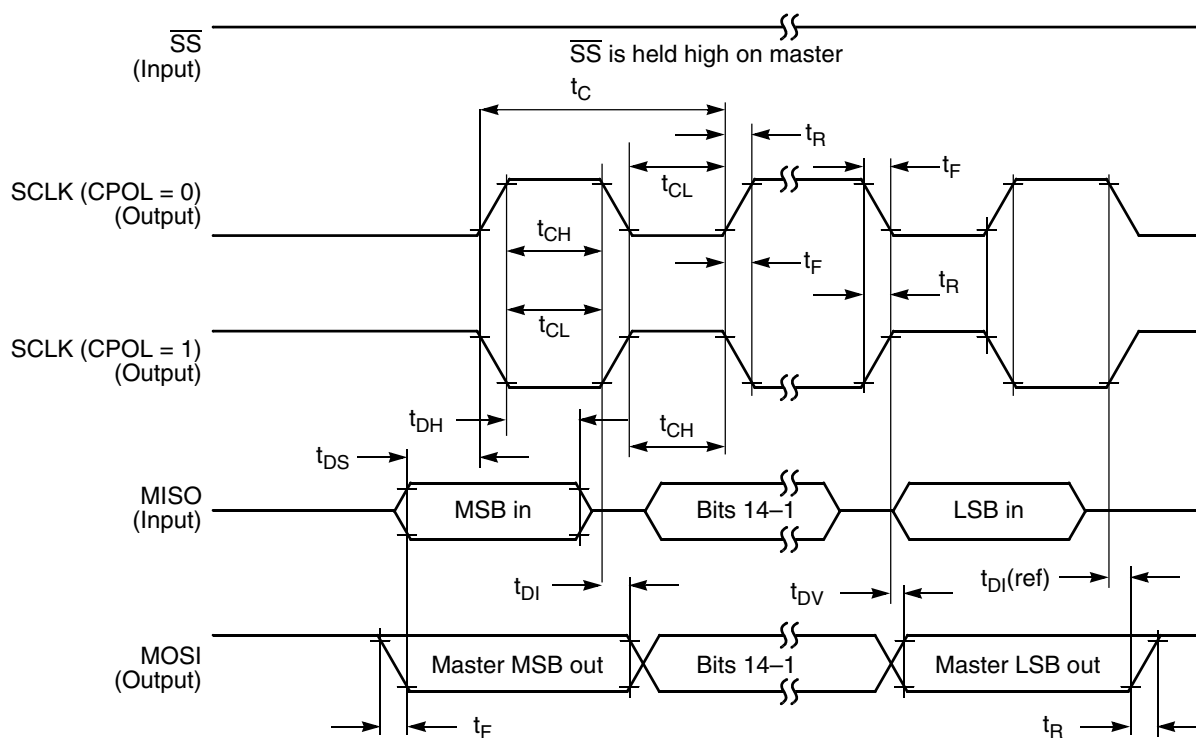

Figure 16. SPI master timing (CPHA = 0)

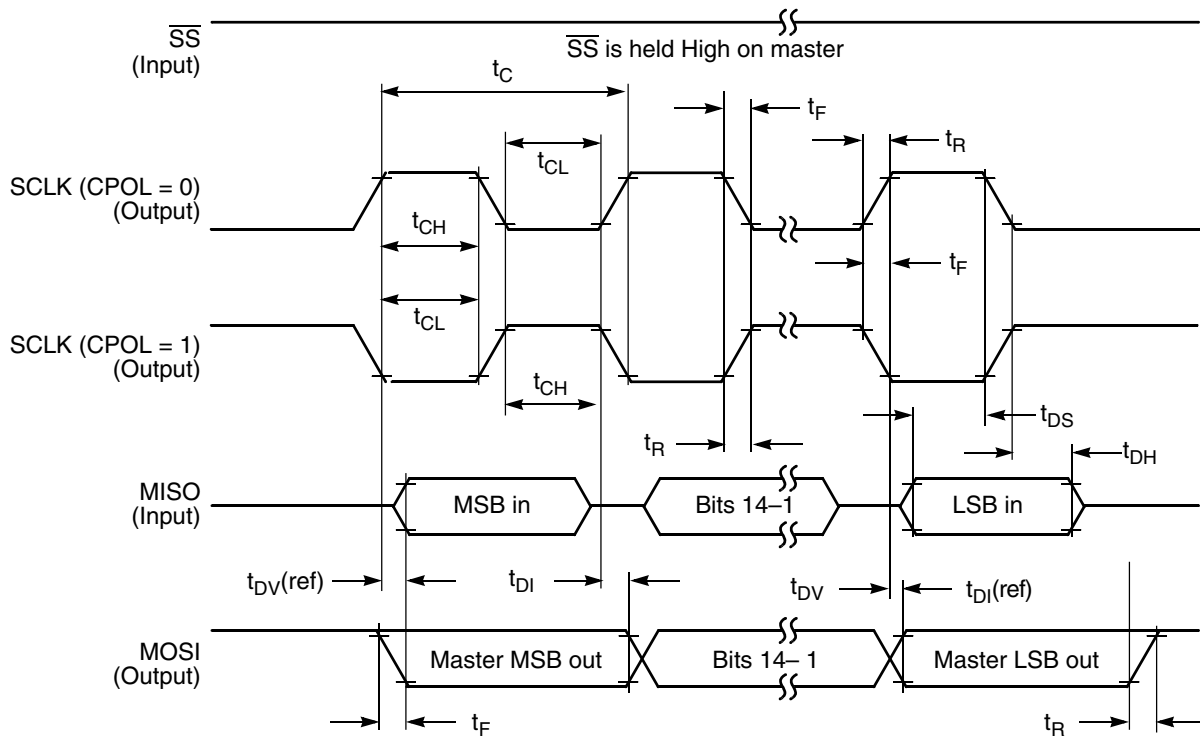

Figure 17. SPI master timing (CPHA = 1)

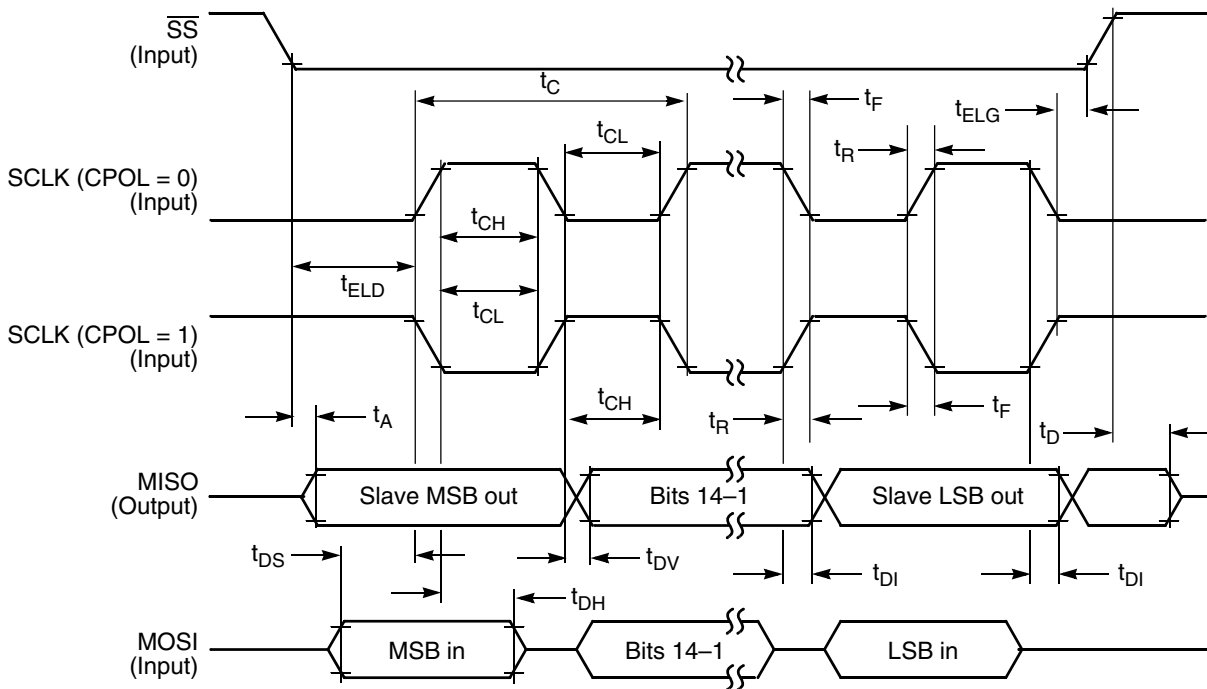

Figure 18. SPI slave timing (CPHA = 0)

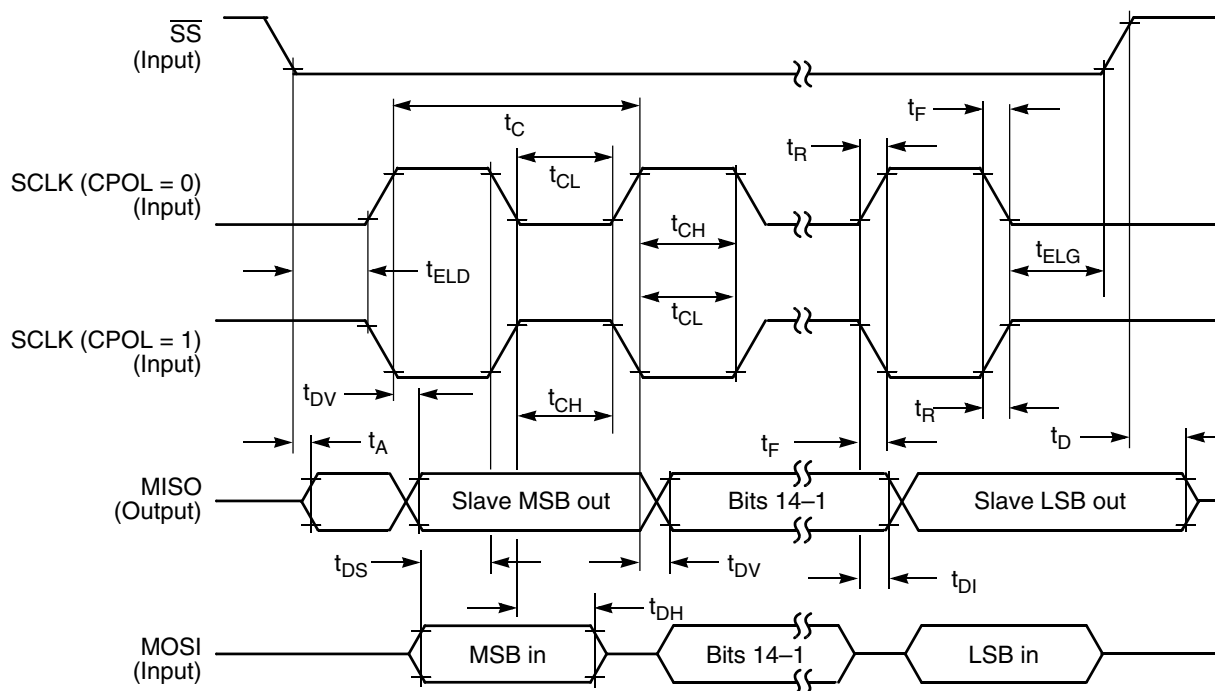

Figure 19. SPI slave timing (CPHA = 1)

10.7.2 Queued Serial Communication Interface (SCI) timing

Parameters listed are guaranteed by design.

Table 35. SCI timing

Characteristic	Symbol	Min	Max	Unit	See Figure
Baud rate ¹	BR	—	(f _{MAX} /16)	Mbit/s	—
RXD pulse width	RXD _{PW}	0.965/BR	1.04/BR	μs	Figure 20
TXD pulse width	TXD _{PW}	0.965/BR	1.04/BR	μs	Figure 21
LIN Slave Mode					
Deviation of slave node clock from nominal clock rate before synchronization	F _{TOL_UNSYNCH}	-14	14	%	—
Deviation of slave node clock relative to the master node clock after synchronization	F _{TOL_SYNCH}	-2	2	%	—
Minimum break character length	T _{BREAK}	13	—	Master node bit periods	—
		11	—	Slave node bit periods	—

1. f_{MAX} is the frequency of operation of the SCI clock in MHz, which can be selected as the bus clock (max.50 MHz depending on part number) or 2x bus clock (max. 100 MHz) for the devices.

Design Considerations

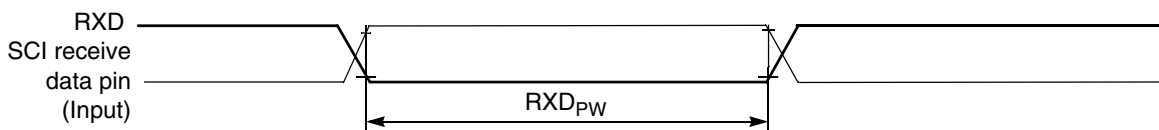

Figure 20. RXD pulse width

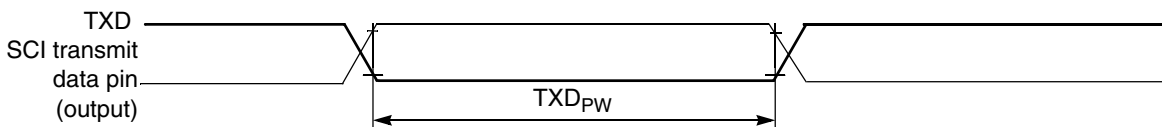

Figure 21. TXD pulse width

10.7.3 LPI²C

Table 36. LPI²C specifications

Symbol	Description		Min.	Max.	Unit	Notes
f _{SCL}	SCL clock frequency	Standard mode (Sm)	0	100	kHz	1, 2, 3
		Fast mode (Fm)	0	400		
		Fast mode Plus (Fm+)	0	1000		
		Ultra Fast mode (UFm)	0	5000		
		High speed mode (Hs-mode)	0	3400		

1. Hs-mode is only supported in slave mode.
2. The maximum SCL clock frequency in Fast mode with maximum bus loading (400pF) can only be achieved with appropriate pull-up devices on the bus when using the high or normal drive pins across the full voltage range . The maximum SCL clock frequency in Fast mode Plus can support maximum bus loading (400pF) with appropriate pull-up devices when using the high drive pins. The maximum SCL clock frequency in Ultra Fast mode can support maximum bus loading (400pF) when using the high drive pins. The maximum SCL clock frequency for slave in High speed mode can support maximum bus loading (400pF) with appropriate pull-up devices when using the high drive pins. For more information on the required pull-up devices, see I²C Bus Specification.
3. See the section "General switching specifications".

11 Design Considerations

11.1 Thermal design considerations

An estimate of the chip junction temperature (T_J) can be obtained from the equation:

$$T_J = T_A + (R_{\Theta JA} \times P_D)$$

where

T_A = Ambient temperature for the package (°C)

R_{ΘJA} = Junction-to-ambient thermal resistance (°C/W)

P_D = Power dissipation in the package (W).

The junction-to-ambient thermal resistance is an industry-standard value that provides a quick and easy estimation of thermal performance. Unfortunately, there are two values in common usage: the value determined on a single-layer board and the value obtained on a board with two planes. For packages such as the PBGA, these values can be different by a factor of two. Which T_J value is closer to the application depends on the power dissipated by other components on the board.

- The T_J value obtained on a single layer board is appropriate for a tightly packed printed circuit board.
- The T_J value obtained on a board with the internal planes is usually appropriate if the board has low-power dissipation and if the components are well separated.

When a heat sink is used, the thermal resistance is expressed as the sum of a junction-to-case thermal resistance and a case-to-ambient thermal resistance:

$$R_{\Theta JA} = R_{\Theta JC} + R_{\Theta CA}$$

where

$R_{\Theta JA}$ = Package junction-to-ambient thermal resistance ($^{\circ}\text{C}/\text{W}$)

$R_{\Theta JC}$ = Package junction-to-case thermal resistance ($^{\circ}\text{C}/\text{W}$)

$R_{\Theta CA}$ = Package case-to-ambient thermal resistance ($^{\circ}\text{C}/\text{W}$).

$R_{\Theta JC}$ is device related and cannot be adjusted. You control the thermal environment to change the case to ambient thermal resistance, $R_{\Theta CA}$. For instance, you can change the size of the heat sink, the air flow around the device, the interface material, the mounting arrangement on printed circuit board, or change the thermal dissipation on the printed circuit board surrounding the device.

To determine the junction temperature of the device in the application when heat sinks are not used, the thermal characterization parameter (Ψ_{JT}) can be used to determine the junction temperature with a measurement of the temperature at the top center of the package case using the following equation:

$$T_J = T_T + (\Psi_{JT} \times P_D)$$

where

T_T = Thermocouple temperature on top of package ($^{\circ}\text{C}/\text{W}$)

Ψ_{JT} = Thermal characterization parameter ($^{\circ}\text{C}/\text{W}$)

P_D = Power dissipation in package (W).

The thermal characterization parameter is measured per JESD51–2 specification using a 40-gauge type T thermocouple epoxied to the top center of the package case. The thermocouple should be positioned so that the thermocouple junction rests on the package. A small amount of epoxy is placed over the thermocouple junction and over about 1 mm of wire extending from the junction. The thermocouple wire is placed flat against the package case to avoid measurement errors caused by cooling effects of the thermocouple wire.

To determine the junction temperature of the device in the application when heat sinks are used, the junction temperature is determined from a thermocouple inserted at the interface between the case of the package and the interface material. A clearance slot or hole is normally required in the heat sink. Minimizing the size of the clearance is important to minimize the change in thermal performance caused by removing part of the thermal interface to the heat sink. Because of the experimental difficulties with this technique, many engineers measure the heat sink temperature and then back-calculate the case temperature using a separate measurement of the thermal resistance of the interface. From this case temperature, the junction temperature is determined from the junction-to-case thermal resistance.

11.2 Electrical design considerations

CAUTION

This device contains protective circuitry to guard against damage due to high static voltage or electrical fields. However, take normal precautions to avoid application of any voltages higher than maximum-rated voltages to this high-impedance circuit. Reliability of operation is enhanced if unused inputs are tied to an appropriate voltage level.

Use the following list of considerations to assure correct operation of the device:

- Provide a low-impedance path from the board power supply to each V_{DD} pin on the device and from the board ground to each V_{SS} (GND) pin.
- The minimum bypass requirement is to place 0.01–0.1 μF capacitors positioned as near as possible to the package supply pins. The recommended bypass configuration is to place one bypass capacitor on each of the V_{DD}/V_{SS} pairs, including V_{DDA}/V_{SSA} . Ceramic and tantalum capacitors tend to provide better tolerances.
- Ensure that capacitor leads and associated printed circuit traces that connect to the chip V_{DD} and V_{SS} (GND) pins are as short as possible.
- Bypass the V_{DD} and V_{SS} with approximately 100 μF , plus the number of 0.1 μF ceramic capacitors.
- PCB trace lengths should be minimal for high-frequency signals.

- Consider all device loads as well as parasitic capacitance due to PCB traces when calculating capacitance. This is especially critical in systems with higher capacitive loads that could create higher transient currents in the V_{DD} and V_{SS} circuits.
- Take special care to minimize noise levels on the V_{REF} , V_{DDA} , and V_{SSA} pins.
- Using separate power planes for V_{DD} and V_{DDA} and separate ground planes for V_{SS} and V_{SSA} are recommended. Connect the separate analog and digital power and ground planes as near as possible to power supply outputs. If an analog circuit and digital circuit are powered by the same power supply, then connect a small inductor or ferrite bead in serial with V_{DDA} . Traces of V_{SS} and V_{SSA} should be shorted together.
- Physically separate analog components from noisy digital components by ground planes. Do not place an analog trace in parallel with digital traces. Place an analog ground trace around an analog signal trace to isolate it from digital traces.
- Because the flash memory is programmed through the JTAG/EOnCE port, SPI, SCI, or I²C, the designer should provide an interface to this port if in-circuit flash programming is desired.
- If desired, connect an external RC circuit to the \overline{RESET} pin. The resistor value should be in the range of 4.7 k Ω –10 k Ω ; the capacitor value should be in the range of 0.1 μ F–4.7 μ F.
- Configuring the \overline{RESET} pin to GPIO output in normal operation in a high-noise environment may help to improve the performance of noise transient immunity.
- Add a 2.2 k Ω external pullup on the TMS pin of the JTAG port to keep EOnCE in a reset state during normal operation if JTAG converter is not present. Furthermore, configure TMS, TDI, TDO and TCK to GPIO if operation environment is very noisy.
- During reset and after reset but before I/O initialization, all the GPIO pins are at tri-state.
- To eliminate PCB trace impedance effect, each ADC input should have a no less than 33 pF 10 Ω RC filter.

11.3 Power-on Reset design considerations

11.3.1 Improper power-up sequence between VDD/VSS and VDDA/VSSA:

It is recommended that VDD be kept within 100 mV of VDDA at all times, including power ramp-up and ramp-down. Failure to keep VDD within 100 mV of VDDA may cause a leakage current through the substrate, between the VDD and VDDA pad cells. This leakage current could prevent operation of the device after it powers up. The voltage

difference between VDD and VDDA must be limited to below 0.3 V at all times, to avoid permanent damage to the part (See the table in "Voltage and current operating ratings" section). Also see the table in "Voltage and current operating requirements" section.

11.3.2 Heavy capacitive load on power supply output:

In some applications, the low cost DC/DC converter may not regulate the output voltage well before it reaches the regulation point, which is roughly around 2.5V to 2.7V. However, the device might exit power-on reset at around 2.3V. If the initialization code enables the PLL to run the DSC at full speed right after reset, then the high current will be pulled by DSC from the supply, which can cause the supply voltage to drop below the operation voltage; see the captured graph (Figure 22). This can cause the DSC fail to start up.



Figure 22. Supply Voltage Drop

A recommended initialization sequence during power-up is:

1. After POR is released, run a few hundred NOP instructions from the internal relaxation oscillator; this gives time for the supply voltage to stabilize.
2. Configure the peripherals (except the ADC) to the desired settings; the ADC should stay in low power mode.
3. Power up the PLL.
4. After the PLL locks, switch the clock from PLL prescale to postscale.
5. Configure the ADC.

12 Obtaining package dimensions

Package dimensions are provided in package drawings.

To find a package drawing, go to nxp.com and perform a keyword search for the drawing's document number:

Drawing for package	Document number to be used
32LQFP	98ASH70029A
32QFN	98ASA00473D
48-pin LQFP	98ASH00962A
64-pin LQFP	98ASS23234W

13 Revision history

The following table provides a revision history for this document.

Table 37. Revision history

Rev.	Date	Substantial Changes
2	11/2022	Initial public release
2.1	02/2023	Minor update in the cover page and the section "Product Family".

How to Reach Us:**Home Page:**nxp.com**Web Support:**nxp.com/support

Limited warranty and liability — Information in this document is believed to be accurate and reliable. However, NXP Semiconductors does not give any representations or warranties, expressed or implied, as to the accuracy or completeness of such information and shall have no liability for the consequences of use of such information. NXP Semiconductors takes no responsibility for the content in this document if provided by an information source outside of NXP Semiconductors. In no event shall NXP Semiconductors be liable for any indirect, incidental, punitive, special or consequential damages (including - without limitation - lost profits, lost savings, business interruption, costs related to the removal or replacement of any products or rework charges) whether or not such damages are based on tort (including negligence), warranty, breach of contract or any other legal theory.

Notwithstanding any damages that customer might incur for any reason whatsoever, NXP Semiconductors' aggregate and cumulative liability towards customer for the products described herein shall be limited in accordance with the Terms and conditions of commercial sale of NXP Semiconductors.

Right to make changes - NXP Semiconductors reserves the right to make changes to information published in this document, including without limitation specifications and product descriptions, at any time and without notice. This document supersedes and replaces all information supplied prior to the publication hereof.

Security — Customer understands that all NXP products may be subject to unidentified or documented vulnerabilities. Customer is responsible for the design and operation of its applications and products throughout their lifecycles to reduce the effect of these vulnerabilities on customer's applications and products. Customer's responsibility also extends to other open and/or proprietary technologies supported by NXP products for use in customer's applications. NXP accepts no liability for any vulnerability. Customer should regularly check security updates from NXP and follow up appropriately.

Customer shall select products with security features that best meet rules, regulations, and standards of the intended application and make the ultimate design decisions regarding its products and is solely responsible for compliance with all legal, regulatory, and security related requirements concerning its products, regardless of any information or support that may be provided by NXP. NXP has a Product Security Incident Response Team (PSIRT) (reachable at PSIRT@nxp.com) that manages the investigation, reporting, and solution release to security vulnerabilities of NXP products.

Suitability for use — NXP Semiconductors products are not designed, authorized or warranted to be suitable for use in life support, life-critical or safety-critical systems or equipment, nor in applications where failure or malfunction of an NXP Semiconductors product can reasonably be expected to result in personal injury, death or severe property or environmental damage. NXP Semiconductors and its suppliers accept no liability for inclusion and/or use of NXP Semiconductors products in such equipment or applications and therefore such inclusion and/or use is at the customer's own risk.

Non-automotive qualified products — Unless this data sheet expressly states that this specific NXP Semiconductors product is automotive qualified, the product is not suitable for automotive use. It is neither qualified nor tested in accordance with automotive testing or application requirements. NXP Semiconductors accepts no liability for inclusion and/or use of non-automotive qualified products in automotive equipment or applications.

In the event that customer uses the product for design-in and use in automotive applications to automotive specifications and standards, customer (a) shall use the product without NXP Semiconductors' warranty of the product for such automotive applications, use and specifications,



and (b) whenever customer uses the product for automotive applications beyond NXP Semiconductors' specifications such use shall be solely at customer's own risk, and (c) customer fully indemnifies NXP Semiconductors for any liability, damages or failed product claims resulting from customer design and use of the product for automotive applications beyond NXP Semiconductors' standard warranty and NXP Semiconductors' product specifications.

Applications — Applications that are described herein for any of these products are for illustrative purposes only. NXP Semiconductors makes no representation or warranty that such applications will be suitable for the specified use without further testing or modification.

Customers are responsible for the design and operation of their applications and products using NXP Semiconductors products, and NXP Semiconductors accepts no liability for any assistance with applications or customer product design. It is customer's sole responsibility to determine whether the NXP Semiconductors product is suitable and fit for the customer's applications and products planned, as well as for the planned application and use of customer's third party customer(s). Customers should provide appropriate design and operating safeguards to minimize the risks associated with their applications and products.

NXP Semiconductors does not accept any liability related to any default, damage, costs or problem which is based on any weakness or default in the customer's applications or products, or the application or use by customer's third party customer(s). Customer is responsible for doing all necessary testing for the customer's applications and products using NXP Semiconductors products in order to avoid a default of the applications and the products or of the application or use by customer's third party customer(s). NXP does not accept any liability in this respect.

Limiting values — Stress above one or more limiting values (as defined in the Absolute Maximum Ratings System of IEC 60134) will cause permanent damage to the device. Limiting values are stress ratings only and (proper) operation of the device at these or any other conditions above those given in the Recommended operating conditions section (if present) or the Characteristics sections of this document is not warranted. Constant or repeated exposure to limiting values will permanently and irreversibly affect the quality and reliability of the device.

Terms and conditions of commercial sale — NXP Semiconductors products are sold subject to the general terms and conditions of commercial sale, as published at <http://www.nxp.com/profile/terms>, unless otherwise agreed in a valid written individual agreement. In case an individual agreement is concluded only the terms and conditions of the respective agreement shall apply. NXP Semiconductors hereby expressly objects to applying the customer's general terms and conditions with regard to the purchase of NXP Semiconductors products by customer.

No offer to sell or license — Nothing in this document may be interpreted or construed as an offer to sell products that is open for acceptance or the grant, conveyance or implication of any license under any copyrights, patents or other industrial or intellectual property rights.

Quick reference data — The Quick reference data is an extract of the product data given in the Limiting values and Characteristics sections of this document, and as such is not complete, exhaustive or legally binding.

Export control — This document as well as the item(s) described herein may be subject to export control regulations. Export might require a prior authorization from competent authorities.

Translations — A non-English (translated) version of a document is for reference only. The English version shall prevail in case of any discrepancy between the translated and English versions.

NXP, the NXP logo, NXP SECURE CONNECTIONS FOR A SMARTER WORLD, Freescale, the Freescale logo, CodeWarrior, are trademarks of NXP B.V. All other product or service names are the property of their respective owners. Oracle and Java are registered trademarks of Oracle and/or its affiliates. The Power Architecture and Power.org word marks and the Power and Power.org logos and related marks are trademarks and service marks licensed by Power.org.

© 2021–2023 NXP B.V.



Looking for pricing, stock, or lifecycle information?

Click below to explore more details on WIN SOURCE:

- ⊖ [View MC56F80646VLFR on WIN SOURCE](#)
- ⊖ [NXP / Nexperia Information](#)

Optimize Your Supply Chain with WIN SOURCE Solutions

- ✓ Global Sourcing Solution
- ✓ Obsolete Management
- ✓ Cost Control Management
- ✓ Shortage Management
- ✓ Alternative Solution
- ✓ Excess Inventory Management